



## Electronic Service Manuals

This electronic document is provided as a service to our customers. We do not create the contents of the information contained in this document. Should you have detailed questions pertaining to the information contained in this document, you may contact Michco, or the manufacturer which provided the original information in this electronic deliverable. Michco's only part in this electronic deliverable was the electronic assembly process. By providing this manual on line we are not guaranteeing parts availability.

You may contact Michco through the following methods:

Phone (517) 484-9312 or (800) 331-3339

2011 N. High St. -- Lansing, Michigan -- 48906

Fax: (517) 484-9836

Email: [CustServe@Michco.com](mailto:CustServe@Michco.com)

Web site: [www.Michco.Com](http://www.Michco.Com)

Parts Web site: [www.FloorMachineParts.Com](http://www.FloorMachineParts.Com)

Order Parts on Line at:

**[www.FloorMachineParts.Com](http://www.FloorMachineParts.Com)**

Directly to Parts & Service:

By Email: **[Shop@Michco.com](mailto:Shop@Michco.com)**

By Fax: (517) 702-2041

By Voice: Use numbers above.

**Serving the Cleaning Industry Since 1922**

Notice: All copyrighted material remains property of original owners, all trademarks are property of respective owners. Manuals are subject to Manufacturer's reproduction limitations. Originals or reproductions were provided by manufacturers through a request. We make no warranty as to the correctness of information provided in this document and you assume all risk. By placing these manuals on line we are not declaring our corporation to be an manufacturer authorized dealer or provider, please check our web site for authorized manufacturers we represent.

# ***OWNER'S MANUAL***

## ***PB 24" Propane Burnisher***



*Powered by the  
EPA/Carb certified  
Kawasaki  
603cc Engine*



***READ THESE  
INSTRUCTIONS  
BEFORE USING***

## **IMPORTANT SAFETY INSTRUCTIONS**

**READ and UNDERSTAND all instructions and warnings before operating this machine!**



### **WARNING**

**Do not store or use gasoline or other flammable vapors and liquids in the vicinity of this machine. Always store equipment away from heater rooms, boilers, gas-fired water heaters or any other source of open flame. Propane is highly flammable. Always store LPG tanks (full or empty) outside in a secure, well ventilated area.**

**NO SMOKING, NO SPARKS, NO FLAMES NEAR UNIT OR LPG TANK.**

**Operate only in well ventilated areas. Buildings must be provided with:**

- A. A continuous mechanical ventilation that removes the products of combustion to the outdoors of not less than 300 CFM for each 10,000 BTUH or fraction thereof; or
- B. Natural ventilation of not less than 300 CFM for each 10,000 BTUH input or fraction thereof, based on a maximum of one-quarter air exchange per hour for the net building volume.

**If you smell LPG gas, stop the unit and check for leaks. Also open windows, don't touch electrical switches, extinguish any open flames. Call your gas supplier if no leaks are found.**

**Do not adjust the fuel system without the proper analysis equipment.**



### **WARNING**

**Never tilt the equipment on its side for pad, belt or brush replacement. It is designed to tilt back on its rear wheel and handle for maintenance and repair. A second person should aid in lifting and securing equipment for repair.**

**Never tilt & transport while engine is running.**

**Keep hands and feet clear of all moving parts.**

**Never try to replace parts or repair equipment with machine running.**

**Turn the gas off at the tank to kill the engine.**

**Remove the LPG tank and store it in an approved area when not in use. A "NO SMOKING" sign should be permanently displayed at the storage area.**

**Always vent an over-full bottle using the tank's bleed valve, out of doors away from all closed places and away from any fire or flame producing device. Vent until the white vapor turns clear.**

**Keep all objects clear of the exhaust system during and after operation.**

**Do not leave this machine unattended while the engine is running.**

**Do not operate equipment in one location for more than a few seconds. Damage to floor surface can occur.**

**Always store equipment away from possible damage by falling objects in warehouse-type areas. Always store LPG tanks outside in a secure, well-ventilated area.**

**When the LPG tank is attached to the machine and not running, the operator should not leave the machine unattended except for short periods of time such as rest stops, washroom or meal stops.**

**The operator must completely understand all instructions, warnings and operating procedures before using this machine.**

**The manufacturer's warranty will be voided if the machine is not maintained in accordance with this manual's recommended maintenance instructions and the engine manufacturer's recommended maintenance procedures. Failure to do so may cause damage to the machine, equipment, furniture, buildings or personal injury!**

**A maintenance record should be kept indicating date of service, hours on engine, and work done.**

## **TRANSPORT & PREPARATION**



### **WARNING**

**Follow the instructions given in this booklet, the Engine's Owners Manual and the training given by your supervisor for the safe operation of this machine. Failure to do so can result in personal injury and/or damage to the machine or property.**

**DO NOT OPERATE THIS MACHINE IN AN EXPLOSIVE ENVIRONMENT!**

**THIS PROPANE MACHINE IS INTENDED FOR COMMERCIAL USE.**

**WARNING**

**Do not use "T" handle when attempting to tilt back machine for service or cleaning. The "T" handle is designed for control during operation only.**

**Do not use excessive vertical pressure.**

**I. PREPARATION****A. Check that the suggested maintenance schedule has been observed:**

All machines are equipped with a multi-function maintenance meter. The functions include the following: hour meter, service alert and tachometer. (See Engine Maintenance Meter Instructions on p4).

**B. Check the engine oil before every operation:**

Make sure the machine is level when checking the oil. Always take 2 readings of the dipstick before adding oil. If the oil level is below the full mark, add just enough oil to the engine to bring the oil level up to the full mark. **Never over fill.** Follow the guidelines in your Engine Owners Manual. Check for foreign material on the dipstick.

**C. Properly fill and check your LPG tank and all LPG fuel lines for leaks:**

1. Every tank has been pressure and leak tested. However, every time a tank is filled and/or connected to the machine it should be soap tested. All LPG lines must be pressurized and every inch of line and connections must be sprayed. If you find a leak, make the proper repairs before operating the machine.

**NOTE:** The connection and disconnection of the LPG tank must be done in a well ventilated area with NO source of ignition within 10 feet (3 meters) from the point of connection.

2. **Never over fill the LPG tank!** The LPG tank is designed to hold just 20 pounds of propane. Make sure to weigh the tank as it is being filled. The gross weight of a full tank should not exceed 48 pounds. If while operating the machine, you notice frost forming on the LPG lines or the regulator, your tank has been over filled. If you continue to operate the machine in this condition, damage will occur. The excess propane in the tank must be removed before normal operations resume. The bleeding of a propane tank should be done in a safe location outside the building. In some cases the regulator must defrost before restarting the engine.

**D. Connecting the high pressure hose to the LPG Tank:**

Make sure the couplers are in line and screwed together hand tight. If this is not done properly, fuel will not pass through to the regulator. Never complete the connection of the tanks to the machine by using a wrench. Always do it by hand. Listen for the rush of fuel to the lock-out device when you open the tank valve. If you hear this, it indicates a good connection has been made at the tank.

**WARNING**

**NEVER CHANGE OR ALTER THE PROPANE CONTROL EQUIPMENT!**

**E. Install fresh pads or brushes before every job:**

To install a fresh pad, set the machine down in the rear. Unscrew and remove the pad-centering ring. Remove the old pad and center the new pad onto the pad driver. Reinstall the pad-centering ring. Never "flip" a pad. Keep the same side down throughout the life of the pad. Even after a pad is cleaned, you can tell the down side by the centering ring indentation. This practice will increase the pad life and help maintain a properly functioning pad driver. **NEVER TILT A MACHINE ON ITS SIDE!**

**II. STARTING THE ENGINE**

**A.** Open propane (LPG) tank valve (counter clockwise).

**B.** Set throttle control at idle.

**C.** Battery start – turn key to the start position & move throttle toward fast position. If engine does not start, release key and return to step "B".

**D.** Electric start – push "Start" button and move throttle toward fast position until engine starts. Starter should not be engaged for more than 10 seconds at a time.

- **When a propane tank is overfilled it may temporarily cause the fuel regulator to malfunction. Remove the tank to a well ventilated location. Release some gas until the cloud disappears and escaping gas is "clear." Reinstall tank.**
- **All machines are equipped with tamper proof fuel systems. If a fuel problem exists, contact an authorized service center.**

- **Propane tanks should be removed & stored in a protected off site area.**

### III. OPERATION

**Provide and use ear protection during operation.**

**Never let an untrained person operate or perform repairs on the machine. They may hurt themselves, damage the floor or the equipment.**

**Engine speed not to exceed 3400 RPM.**

**This machine is not suitable for picking up hazardous dust.**

**Do not use on surfaces with a gradient exceeding 2%.**

### IV. STOPPING THE ENGINE

Turn the propane tank valve clockwise to a closed position and turn the key OFF.

**NOTE:** The exhaust system will be very hot and takes several minutes to cool, so keep yourself and all materials clear.

### V. PROCEDURES

Follow machine (straight ahead) at moderate walking speed. Keep moving.

- **Do not operate the machine in one location for more than a few seconds — it will damage — “burn” the finish.**
- **When operation is completed remove tank and store in a secure, protected off site (preferably outdoor) location.**
- **Do not use for scrubbing operations.**
- **Never tilt back machine to maintenance position while engine is running.**
- **Never reach under protective shroud when engine is running.**

### VI. MAINTENANCE

#### A. Machine & engine maintenance

1. Refer to engine manufacturer's owners manual and comply completely with the instructions. Change the oil and filter according to the Engine Owners Manual.
2. Keep a good service log on each machine with the date, hour meter reading, type(s) of service performed and the name of the person who performed them.
3. Clean the entire unit after each use. When

cleaning the unit, check for possible loose nuts and bolts.

#### B. Engine maintenance meter

This multi-function meter acts as a preventive maintenance tool, which benefits you with increased fuel economy, less down-time and longer engine life. The meter's displays are:

**Hour Meter:** Displays total run hours when machine is off.

**Tachometer:** Indicates engine RPM during operation.

**Service Alert:** The display flashes to alert you to lube and change the oil at 25 hour intervals. The service alert only flashes during operation and it warns you to change the oil for only two hours. After the two hours is reached, the alert will automatically reset to the next 25 hour interval. Therefore, it is recommended that a separate maintenance log be kept to track oil changes.

**Remember that being safe is a full-time, every day job. Follow all information posted on the machine and the LPG tank.**

**Never allow anyone to operate this machine who has not read or cannot understand the given instructions.**

#### C. Troubleshooting the electrical system

1. Check all wire connections for obvious problems. Remove LPG tank, then remove battery box cover. Check all connections visibly and physically. If any “loose”, damaged or unconnected wires are noticed, replace or repair as needed.
2. Check the battery posts and wires. **Always wear a face shield, safety glasses and protective clothing when working around a battery!** The gases can be explosive and the acid is highly corrosive to metals, cloth and ALL HUMAN TISSUE (skin, eyes, etc.) If the battery post(s) are corroded, remove the wires and clean posts and wires. Applying some axle grease on the posts of the battery after they are cleaned will slow down the battery corrosion process.

If nothing obvious is noted, a more detailed investigation is warranted. Before any such troubleshooting begins, the following things should be done:

- a. Replace propane LPG tank with one from a machine that runs.
- b. Charge the battery or provide an absolute source of 12 volt DC power capable of 50

amperes total output. (A pair of good jumper cables from your car or truck battery will suffice.) Equip yourself with an inexpensive 12 volt test light.

c. If the trouble seems to be in the electrical control equipment, you may wish to disconnect the starter from the system so as to check the system without spinning the engine.

d. Battery rundown. A common problem is letting the battery run down. What usually happens is that it takes the crew a few jobs to get used to the whole system, so the machine is stopped and started quite often. Key left in on position, when engine is turned off, will result in battery running down – dying.

## D. Belt Inspection & Replacement

### Inspection

- Fold T-Handle to forward position
- Tilt machine back on rear of body & handle
- If belt is worn, cracked or shredding, belt needs to be replaced.

## VII. PAD DRIVE FACING, BELT, IDLER PULLEY, OR DRIVE SHAFT REPLACEMENT

A. Adjust the handle to enable the buffer to stand on rear wheels.

- **Handle must be in shipping (forward) position to insure stability in the “tilt back” position. A second person should aide in the lift and to secure the buffer while being serviced.**
- **Do not use “T” handle when attempting to tilt back machine for service or cleaning. “T” handle is designed for control during operation — Do not use excessive vertical pressure.**

B. Remove pad drive nut & pad centering device and four (4) bolts (9/16" wrench).

C. Remove pad drive. (Replace if worn.)

D. Remove idler pulley. (Replace if worn.)

E. Remove belt(s). (Replace if worn.)

F. To remove driveshaft unit: Remove retaining bolt & clip — pull driveshaft out of housing — use of a slide hammer may assist in removal (do not pry with crow bar.) While drive shaft is removed, spin bearings. If roughness is felt, bearing replacement may be necessary.

G. To reassemble, reverse order of all steps taken previously.

## KAWASAKI ENGINES

### Tune-up Specifications

ITEM	SPECIFICATIONS
Ignition Timing	Unadjustable
Spark Plugs: Gap	Champion – RCJ8Y 0.75 mm (0.30 in)
Low Idle Speed	1500 RPM
High Idle Speed	3400 RPM
Valve Clearance	IN: 0.10-0.15 mm (0.004-0.006 in) EX: 0.10-0.15 mm (0.004-0.006 in)
Other Specifications	No other adjustment needed

**NOTE:** High and low idle speeds may vary depending on the equipment on which the engine is used. Refer to the equipment specifications.

### Engine Oil

Check the engine oil daily before starting the engine otherwise shortage of the engine oil may cause serious damage to the engine such as seizure.

- Place the engine on a level surface. Clean the area around the oil gauge before removing it.
- Remove the oil gauge and wipe it with a clean cloth.
- Pour the oil slowly to “FULL” mark on the oil gauge.
- Insert the oil gauge into the tube **WITHOUT SCREWING IT IN.**
- Remove the oil gauge to check the oil level. The oil level should be between “ADD” and “FULL” marks. Do not overfill.
- Install and tighten the oil gauge.

**The following engine oils are recommended:**

API Service Classification: SF, SG, SH, or SJ.

### Oil Viscosity

Choose the viscosity according to the temperature as follows:

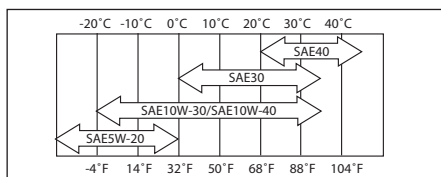

**NOTE:** Using multi grade oils (5W-20, 10W-30, and 10W-40) will increase oil consumption. Check oil level more frequently.

**Engine Oil Capacity**

FH381V, FH500V, FH541V: Fill to 1.5 L (1.6 US qt.) when oil filter **is not** removed. Fill to 1.7 L (1.8 US qt.) when oil filter **is** removed.

**Oil Change**

Change oil after **first 8 hours of operation**. Thereafter change oil **every 50 hours**.

- Run the engine to warm oil.
- Be sure the engine (equipment) is level.
- Stop the engine.
- Open the oil drain valve and drain the oil into suitable container while engine is warm.

**! WARNING!**

**Hot engine oil can cause severe burns. Allow engine temperature to drop from hot to warm level before draining and handling oil.**

**Oil Drain Plug**

- Close the oil drain valve.
- Remove oil gauge and refill with fresh oil (See "Recommended Oils" on p5).
- Check the oil level (see "Preparation" on p3 for oil level check).

**Oil Filter Change**

- Change the oil filter **every 100 hours** of operation.

**! WARNING!**

**Hot engine oil can cause severe burns. Allow engine temperature to drop from hot to warm level before attempting to remove oil filter.**

**! CAUTION!**

**Before removing the oil filter, place a suitable pan under filter connection.**

- Drain engine oil into a suitable container.
- Rotate the oil filter (A) counterclockwise to remove it.
- Coat a film of clean engine oil on seal of new filter.
- Install new filter rotating it clockwise until seal contacts mounting surface (B). Then rotate filter 3/4 turn more by hand.
- Supply engine oil as specified.
- Run the engine for about 3 minutes, stop engine, and check oil leakage around the filter.
- Add oil to compensate for oil level drop due to oil filter capacity (See "Oil Level Check" on p3).

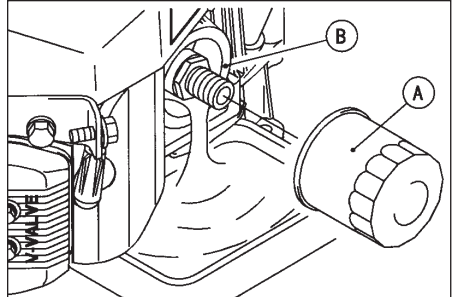

**! WARNING!**

**Engine oil is a toxic substance. Dispose of used oil properly. Contact your local authorities for approved disposal methods or possible recycling.**

**KAWASAKI ENGINE BATTERY START WIRING DIAGRAM**

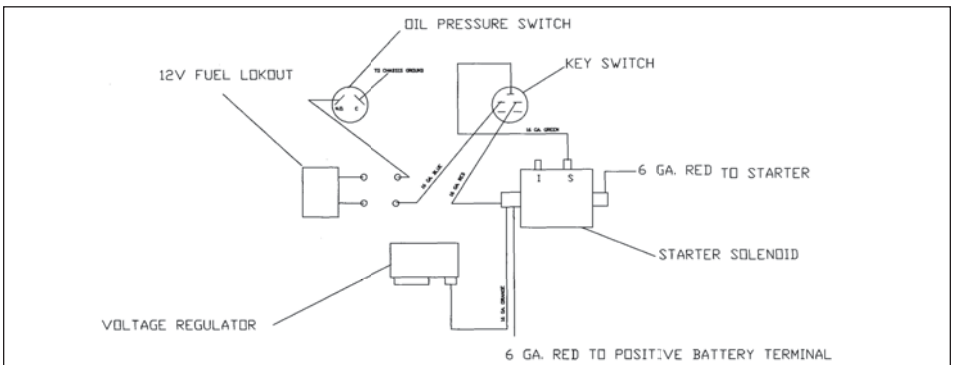

## KAWASAKI ENGINE MAINTENANCE SCHEDULE

MAINTENANCE	INTERVAL						
	Daily	First 8 hr.	Every 25 Hr.	Every 50 hr.	Every 100 hr.	Every 200 hr.	Every 300 hr.
Check and add engine oil	•						
Check for loose or lost nuts and screws	•						
Check for fuel and oil leakage	•						
Check battery electrolyte level	•						
Check or clean air intake screen	•						
Clean air cleaner foam element			•				
Clean air cleaner paper element				•			
Clean dust and dirt from cylinder and cylinder head fins					•		
Tighten nuts and screws					•		
Change engine oil		•		•			
Clean and gap spark plugs					•		
Change oil filter					•		
Replace air cleaner paper element					•		
Clean combustion chambers							•
Clean and adjust valve clearance				•*			•
Clean and lap valve seating surface							•

\*After the 1st 50 hours

## ENGINE TROUBLESHOOTING

### COMMON PROBLEMS & PROBABLE CAUSES

#### Engine cranks but will not start

- Fuel cylinder is empty
- Shutoff valve is closed
- Clogged, obstructed, kinked or cut fuel or vacuum line
- Spark plug lead disconnected
- Faulty choke or throttle settings
- Faulty ignition coil
- Faulty kill switch
- Faulty regulator

#### Engine starts hard

- Faulty choke or throttle settings
- Clogged, obstructed, kinked or cut fuel or vacuum line
- Faulty regulator
- Low compression

#### Engine will not crank

- Battery is discharged
- Loose or faulty connections or wires
- Faulty ignition key switch or starter control switch

#### Engine overheats

- Incorrect fuel settings
- Air intake filter screen or cooling fins clogged
- Low oil level

#### Exhaust emissions or propane odor

- Carburetor or regulator setting incorrect
- Dirty or clogged air filter
- Choke engaged
- Loose fittings, clamps or hoses cracked, hoses cut or leaking

### SOLUTIONS

Refill cylinder  
Open valve  
Remove obstruction or replace line  
Connect lead to spark plug  
Set controls to correct positions  
Replace coil  
Replace switch  
Replace regulator

Set controls to correct position  
Remove obstruction or replace line  
Replace regulator  
Valves need adjustment  
Have engine serviced by a trained technician

Charge or replace battery  
Tighten, repair or replace wires  
Repair or replace switch(es)

Have engine serviced  
Clean and clear debris or replace filter  
Check and add oil

Have engine serviced by a trained technician  
Replace air filter  
Adjust to correct settings  
Tighten or seal; check with soap and water solution, if bubbles appear, part is still leaking; replace

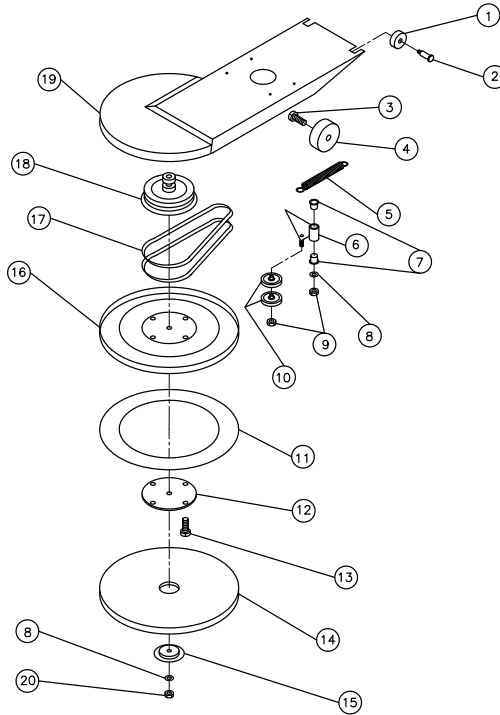

**PARTS LIST FOR BUFFER BODY ASSEMBLY**

REF #	DESCRIPTION	PART #	QTY
1	POLYWHEEL	156-PB-03041-08	2
2	1 3/4" SHOULDER BOLT	196-70212	2
3	3/8-16 x 2" BOLT (21"-27" MODELS)	164-10123	2
	3/8-16 x 2 1/2" BOLT (24" MODELS)	164-10127	2
4	4" WHEEL (21" MODELS)	156-SRB-4H3	2
	5" WHEEL (24"-27" MODELS)	156-ACPLY-5J3	2
5	TENSION SPRING	173-7599-DWG	1
6	BELT TENSION IDLER (21" MODELS)	011-862I	1
	BELT TENSION IDLER (24"-27" MODELS)	011-762I	1
7	NYLON BUSHINGS	196-71200	2
8	5/16 FLAT WASHER	164-20156	2
9	3/8-16 HEX NUT	164-22004	2
10	BELT TENSION PULLEY (21" MODELS)	188-F4412	1
	BELT TENSION PULLEY (24"-27" MODELS)	188-V42B	2
11	MIGHTY LOK RING (21" MODELS)	254-16*20.5	1
	MIGHTY LOK RING (24" MODELS)	254-17.5*23.25	1
	MIGHTY LOK RING (27" MODELS)	254-20.5*26.25	1
12	WASHER PLATE (21" MODELS)	283-Q333-R2	1
	WASHER PLATE (24"-27" MODELS)	283-Q333-R3	1
13	3/8-16 x 3/4" BOLT	164-10111	4
14	BIEGE PAD (21" MODELS)	250-PT21	1
	BIEGE PAD (24" MODELS)	250-PT24	1
	BIEGE PAD (27" MODELS)	250-PT27	1
15	DRAWN CUP	001-962DC	1
16	PAD DRIVER (21" MODELS)	011-862PD	1
	PAD DRIVER (24" MODELS)	011-462PD	1
	PAD DRIVER (27" MODELS)	011-762PD	1
17	BELT (21" MODELS)	113-345	1
	BELT (24" MODELS)	113-L548	2
	BELT (27" MODELS)	113-L549	2
18	DRIVESHAFT (21" MODELS)	011-962DS	1
	DRIVESHAFT (24"-27" MODELS)	011-762DS	1
19	BODY FRAME (21" MODELS)	011-871F	1
	BODY FRAME (24" MODELS)	011-471F	1
	BODY FRAME (27" MODELS)	011-771F	1
20	3/8-16 STOVER LOK NUT	164-22834	1

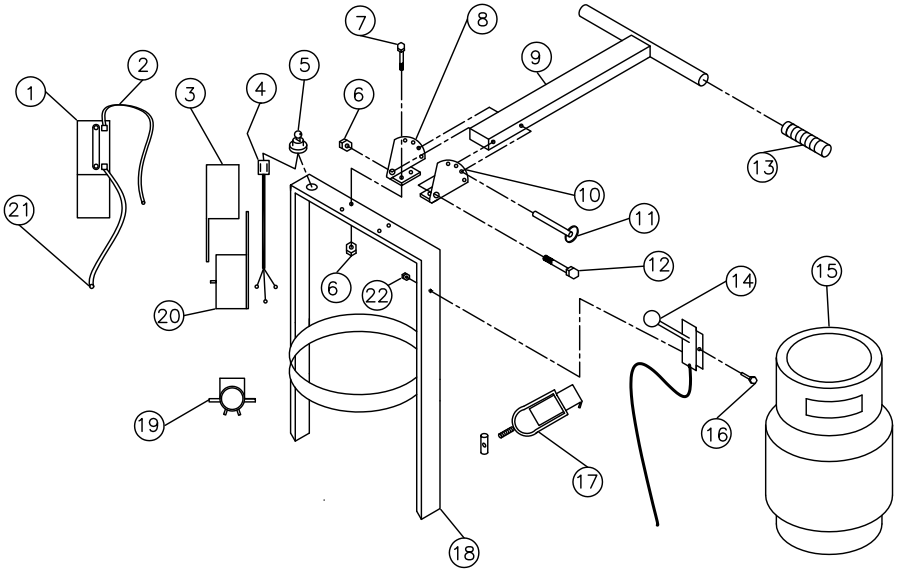

**PARTS LIST FOR BUFFER HANDLE ASSEMBLY**

<b>PART #</b>	<b>DESCRIPTION</b>	<b>PART #</b>	<b>QTY</b>
1	BATTERY	276-GTX14	1
2	(-) BATTERY CABLE	153-6-10	1
3	BATTERY BOX TOP COVER	283-11-2127T	1
4	WIRE HARNESS	011-762-WHK	1
5	KEY SWITCH	312-308-0385	1
6	3/8-16 LOK NUT	164-22834	5
7	3/8-16X1" HEX BOLT	164-10115	4
8	RIGHT HANDLE BRACKET	283-025-500	1
9	T-HANDLE	283-025-600	1
10	LEFT HANDLE BRACKET	283-025-400	1
11	LOCK PIN	625-98404A385	1
12	3/8-16X3" BOLT	164-10131	1
13	HANDLE GRIP	224-1	2
14	THROTTLE CABLE	196-60314	1
15	20 LB. LPG CYLINDER	293-20#STLMF	1
16	1/4-20X1 1/2" HEX BOLT	164-10015	1
17	TOGGLE & NUT	284-TB44	1
18	HANDLE FRAME (21" MODELS)	011-871BH	1
	HANDLE FRAME (24-27" MODELS)	011-471BH	1
19	STARTER SOLENOID	296-SS581	1
20	BATTERY BOX BOTTOM	283-11-2127B	1
21	(+) BATTERY CABLE	153-6-16.5	1

FUEL SYSTEM

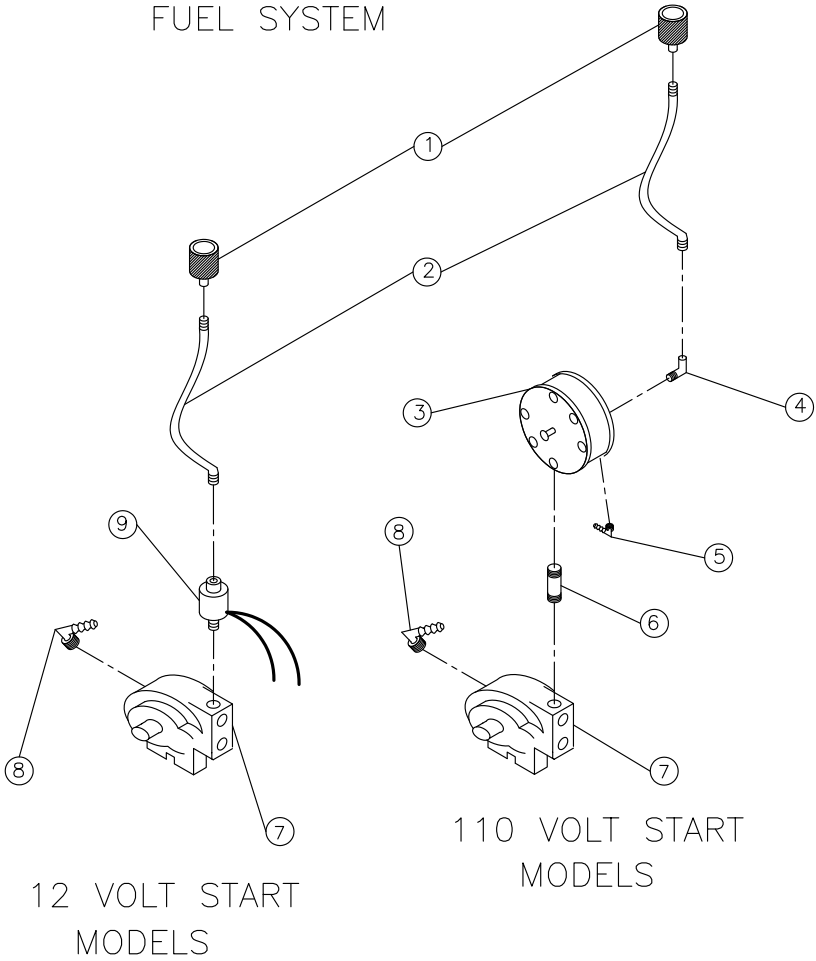

**PARTS LIST FOR BUFFER FUEL SYSTEM**

PART #	DESCRIPTION	PART #	QTY
1	QUICK COUPLER	152-700	1
2	LPG HOSE 14"	267-P5561-14	1
	LPG HOSE 20"	267-P5561-0410	1
3	FUEL LOK-OUT (VACUUM)	152-300	1
4	90° FITTING	177-116B04	1
5	VACUUM HOSE FITTING	166-62029	1
6	1 1/2" NIPPLE	177-56021	1
7	FUEL REGULATOR (T60-E)	152-500	1
8	FUEL HOSE FITTING	166-62039	1
9	FUEL LOK-OUT (12 VOLT)	152-N3-0173-1	1

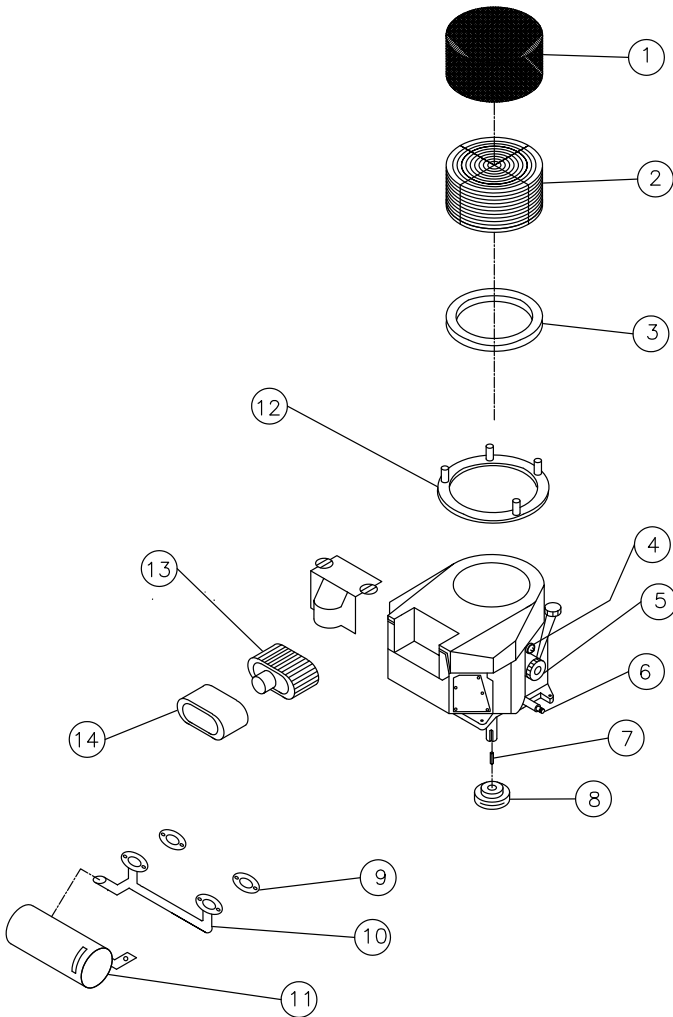

**KAWASAKI 603cc ENGINE**

PART #	DESCRIPTION	PART #	QTY
1.	Foam Hat Filter	186-271964	(1)
2.	Debris Screen	309-18540	(1)
3.	Foam Hat Seal	175-7.75*9.25*1	(1)
4.	Oil Pressure Switch	152-N3-0082	(1)
5.	Oil Filter	309-49065-7007	(1)
6.	Oil Drain Valve	312-504-0185	(1)
7.	1 / 4 x 1 1 / 4 Key	199-NHNT-SE UND	(1)
8.	Crank Pulley (21" Model)	172-BS32	(1)
	Crank Pulley (24" Model)	172-2BK34-1	(1)
	Crank Pulley (27" Model)	172-2BK28-1	(1)
9.	Exhaust Manifold Gasket	309-11060-7016	(2)
10.	Exhaust Manifold	152-603-MAN	(1)
11.	Catalytic Muffler	152-603-MUF	(1)
12.	Debris Screen Adapter	283-040-2250	(1)
13.	Air Filter Element	309-11013-7049	(1)
14.	Foam Pre Filter	309-11013-7046	(1)

**NOTES**

**NOTES**