



Electronic Service Manuals

This electronic document is provided as a service to our customers. We do not create the contents of the information contained in this document. Should you have detailed questions pertaining to the information contained in this document, you may contact Michco, or the manufacturer which provided the original information in this electronic deliverable. Michco's only part in this electronic deliverable was the electronic assembly process. By providing this manual online we are not guaranteeing parts availability.

You may contact Michco through the following methods:

Phone (517) 484-9312

2011 N. High St. -- Lansing, Michigan -- 48906

Fax: (517) 484-9836

Email: CustomerService@Michco.com

Website: www.Michco.Com

Order Parts online at:

www.Michco.Com

Directly to Parts & Service:

By Email: **CustomerService@Michco.com**

By Fax: (517) 484-9836

By Voice: (517) 484-9312

Serving the Cleaning Industry Since 1922

Notice: All copyrighted material remains property of original owners, all trademarks are property of respective owners. Manuals are subject to Manufacturer's reproduction limitations. Originals or reproductions were provided by manufacturers through a request. We make no warranty as to the correctness of information provided in this document and you assume all risk. By placing these manuals on line we are not declaring our corporation to be an manufacturer authorized dealer or provider, please check our web site for authorized manufacturers we represent.

POWERMATE

OWNER'S MANUAL

This equipment is intended for commercial use only

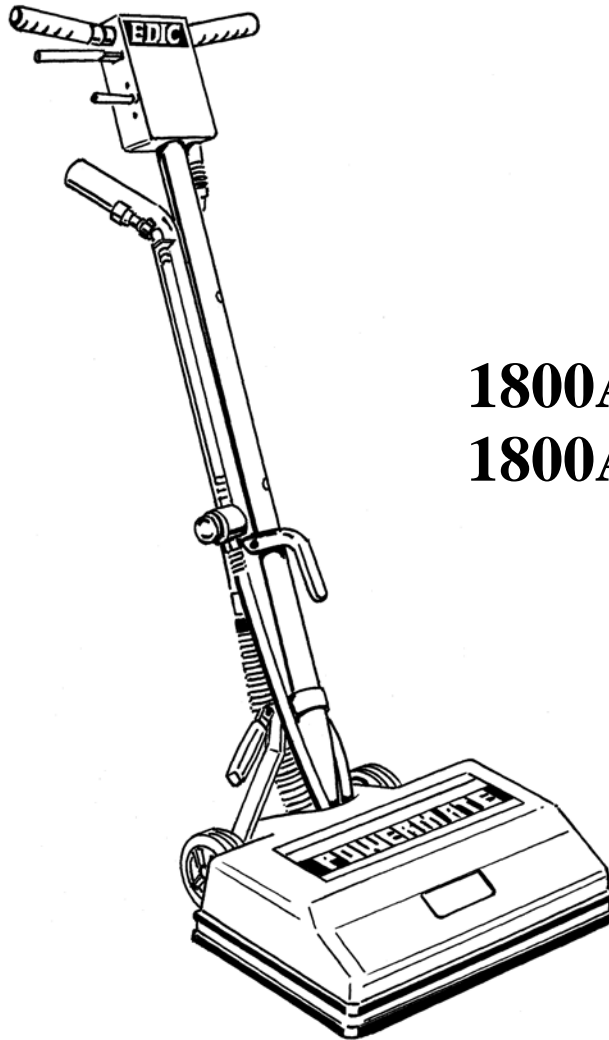

1800AC-100
1800AC-200

EDIC

BEFORE OPERATING THE MACHINE

Read the manual carefully and completely before attempting to operate the unit. This manual has important information for the use and safe operation of the machine. Keep this manual handy at all times. This machine will ensure years of satisfactory service if operated and maintained to recommendations in the manual. If additional information is needed, please contact your local distributor or write to:

EDIC
1753 Blake Avenue
Los Angeles, CA 90031-1006

All information and specifications printed in the manual and parts list are current at the time of printing. However, because of EDIC's policy of continual product improvement, we reserve the right to make any changes at any time without notice.

WARNING!

- The machine was designed for the use and instructions and recommendations written in this manual. Any deviation from its proper use or purpose and the consequential damage that may occur is the sole responsibility of the end user.
- Disconnect the power cord from the outlet before servicing. Do not leave the machine connected to any electrical outlet when unattended.
- The cord on this machine should not be used to pull or carry the machine. Keep the cord away from hot surfaces, sharp edges or corners. Do not close door on cord or run machine over cord.
- Do not immerse or use this machine in standing water. Such use may cause electric shock.
- This machine is not designed to handle or use combustible/ volatile substance such as gasoline or kerosene, in, or near the machine. The use of such materials will cause an extreme hazard condition.
- To unplug the machine, grasp the plug, not the cord. Avoid pulling on cord.
- When using an extension cord, use only a 3-conductor grounding cord, 14 ga. wire or heavier.
- Keep openings free of any objects, such as dust, lint or hair, which may reduce airflow. Avoid use if openings are blocked.
- To avoid electric shock, do not expose the unit to rain. Store it indoors only.
- Avoid picking up cigarettes, matches, hot ashes or anything that is smoking or burning.
- Do not expose machine to freezing temperatures.
- Do not use replacement parts other than those specified in the parts list.

**FAILURE TO COMPLY WITH THE ABOVE WARNING INSTRUCTIONS WILL
VOID THE WARRANTY.**

OPERATING THE MACHINE

1. Connect the cord on the power wand to the optional receptacle on the back of the machine or use the optional adaptor cord to plug directly into a wall outlet. Turn on the vacuum and pump switches on the extractor.
2. The motor of the rotating power brush is operated with your right hand controlling a long toggle switch. Pull it up for momentary use, push it down for continuous brush action (center is off). Solution application is controlled by depressing the flow switch lever with your right hand fingertips.
3. To adjust the handle into operating position, pull up the grip on the locking lever located near the base of the handle. Move handle to waist level height and push down grip handle on lever to lock into place.
4. To move the power wand forward, push handle downward to raise the front end and move the wand into position. To pre-spray, depress the flow switch (solution control) while moving wand forward or backward over the area to be cleared with the front end raised.
5. To clean, depress the solution flow lever while pulling the power wand towards you.

Here's how it works- The solution is jet sprayed deep into the carpet to loosen dirt. The rotating brush scrubs the fiber and breaks up surface and deep rooted dirt. It fluffs the nap without distortion to the pile. With the weight of the base on the suction head, the vacuum picks up the dirt and solution. Make overlapping passes to prevent streaking.

6. Make a pass over the path you just cleaned without depressing the solution flow lever (vacuum only) and with the brush still on, to remove as much dirt and solution as possible.

PERIODIC MAINTENANCE

All EDIC machines are engineered and built to require a minimum amount of maintenance. But like any machine, it does require some care to keep it in optimum working condition. Careful attention to these maintenance instructions will give you maximum operating performance and will increase the life expectancy of your machine.

1. Always keep the machine clean inside and out. Keep brush clean.
2. Flush the machine at least once a month with a solution of 3 parts water to 1 part white vinegar in order to neutralize the alkaline residue left by the cleaning solution.
3. Spray a light lubricant on the quick connect coupler to prevent sticking.

1800AC-100 HANDLE

ITEM #	PART #	DESCRIPTION	QTY
1	C11619	ALLEN WRENCH, .31 IN	1
2	11507A	ASSEMBLED LOCKING HANDLE, CORD HOOK	1
3	C11558	LOCKNUT, BLACK OXIDE, THIN	2
4	D11507-2	CORD HOOK BODY	1
5	D11507	CORD HOOK CLAMP	1
6	C11502	SOCKET CAP SCREW, .375-16 X 2.5 IN	1
7	C11537	DOWEL PIN, .31 X 1.5 IN	1
8	D11497	HANDLE, LOCKING CLAMP	1
9	C11538	CAP NUT, .31 IN, PUSH ON	1
10	C00259	WASHER, SLOTTED, ZINC	1
11	C11536	SPADE BOLT, .375-16 X 4 IN	1
12	B00177	TERMINAL LUG, FEMALE, QD, .25 X .032, 16-14 AQQ	4
13	B00179-1	CLOSED END CNTR, 16-3	2
14	B00222	CABLE, 18-4 X 44 IN, SJTO	1
15	B10734	STRAIN RELIEF, HANDLE	1
16	B11199	STRAIN RELIEF, PIGTAIL	1
17	B00218-1	POWERCORD, BRITISH, 25'	1
18	C00323	SCREW, .25-20 X 2.25 IN OVAL HEAD	2
19	B02191	CIRCUIT BREAKER, 1.5 AMP	1
20	B02199	FEMALE CONNECTOR, .110 FED, FULLY INSULATED	2
21	B00185-41	WIRE, 16 GA BLACK, ULCSA, 600V, -60C TO +200C	2
22	C00284	SCREW, 10-32 X .375 GROUND	1
23	B00209	MOMENTARY MICROSWITCH	1
24	B11518	SWITCH INSULATION	1
25	B00180-10-1	RING TERMINAL, #10 CENTER	6
26	B00190	NYLON TIE, 4 IN	2
27	C11541	WASHER, .375IN, STAR	1
28	C00239	WASHER, .5 IN, FLAT	1
29	B00208	SWITCH, TOGGLE, MOM OFF-ON	1
30	C00249	WASHER, NON- ROTATIONAL	1
31	B00210	TOGGLE LEVER, BLACK	1
32	D00339	PW 18 SOLUTION LEVER	1
33	K00722	SOLUTION GRIP, 1800AC	1
34	D00410-1	CORD CLAMP, 18-3	2
35	K11498	HANDLE GRIP, FLOOR MACHINE	2
36	D11479-1	HANDLE, PW-18	1
37	D00361	SPRING, SWITCH, LEVER, 1800AC	2
38	C00306	ROLL PIN, .125 X 1.75	2
39	C00252	WASHER, .375 IN, FLAT	1
40	C11528	SCREW, 10-32 X .25 IN	1
41	H00556-1	LABEL, EDIC, BLUE & WHITE	1
42	D11496B	SWITCH BOX COVER, BLACK	1
43	H00559	LABEL, INSTRUCTION, 1800AC	1
44	C11529	SCREW, 10-32 X .375 IN	2
45	B00181	WIRE SPLICE, BLUE, 1 WIRE	2
46	A00102	QD, 1-4F X 1-4FP	1
47	A00053	45 ELBOW, .25MP X .25FP	1
48	C00240	WASHER, SHOULDER, NYLON	3
49	13115A	UPPER HOSE ASSY, 13 IN	1
50	K11935	STRAINER, INLINE, .5IN	1
51	D02425	TUBE, BRACKET, PW 18	1
52	13116A	LOWER HOSE ASSY, 23 IN	1
53	C02328	SCREW, ALLEN HEAD, 10-24 X .375 IN	1
54	C02249	LOCKWASHER, #10INT, STR, SS	1
55	C00254	LOCKWASHER	2
56	C00313	HEX BOLT, .25-20 X .75 IN	2
57	D00354	VACTUBE, PW18, 45 X 1.5 IN	1
58	J00650	SCREW CLAMP, #24, 1.25 IN	2
59	J00625	CUFF, 1.5IN, GREY	2
60	J00616-10	VACUUM, HOSE, 1.5 X 19 IN	1

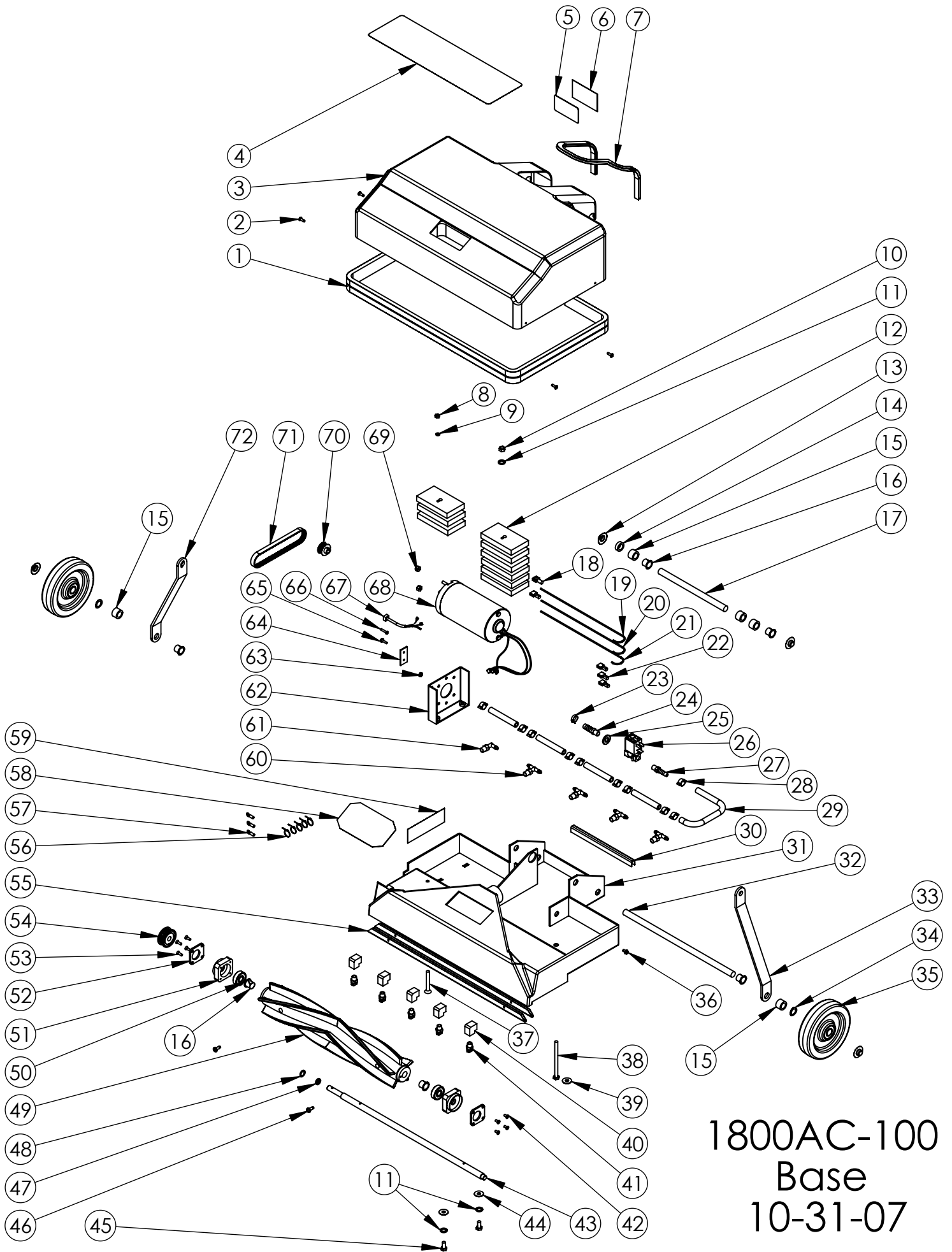

1800AC-100
 Base
 10-31-07

1800AC-100 BASE

ITEM #	PART #	DESCRIPTION	QTY
1	E00440	BUMPER EXTRUSION, 52 IN	1
2	C00293	SCREW, 50 IN, BLACK	4
3	F00480B	COVER, BLACK	1
4	H00547-12	LABEL, 1800AC	1
5	H00565-5	LABEL, SERIAL NUMBER	1
6	H03545	COVER, SERIAL # LABEL	1
7	E00445-19A	BUMPER, .50 IN X 19IN	1
8	C00264	HEX NUT, 10-32, SS	1
9	C02315	LOCKWASHER, #10 INT, STR, SS	1
10	C00261	NUT, .25-20, HEX	1
11	C00254	LOCKWASHER	3
12	D00356-2	COUNTER-WEIGHT, PW18	9
13	C02305	CAP NUT, .5IN PUSH-ON	4
14	K11561	SPACER, .25LG, NYLON, NATURAL	1
15	K00662-50	SPACER, .50LG, NYLON, NATURAL	5
16	K00674	BUSHING, .50IN, NYLON	6
17	D00418-9	AXLE, HANDLE, .5 X 7.56 IN	1
18	B00178	TERMINAL LUG, MALE, QD	1
19	B00185-31	WIRE, 16 GA, WHITE, UL1015	1
20	B00185-41	WIRE, 16 GA, BLACK, UL-CSA	1
21	B00185-61	WIRE, 16 GA, GRN-YEL, UL1015	1
22	B00177	TERMINAL LUG, FEMALE, QD, .25 X .032	4
23	J11508	SCREW CLAMP, #6, .43 TO .875 IN	1
24	A00077	.375 BARB X .125 MP	1
25	C00252	WASHER, .375 IN, FLAT	1
26	G02536	SOLENOID VALVE	1
27	A00076	.25 BARB X	1
28	J00635	OETIKER CLAMP, 1-2 IN	10
29	J00596	HOSE, BRAIDED, .25 X .21 IN	1
30	E00445-1A	BUMPER, .50 IN X 7 IN	1
31	D00404	BRUSH CHAMBER ASSY	1
32	D00418-12	AXLE, WHEEL, .5 X 12.5 IN	1
33	D11481	HANDLE, BRACE, LEFT, BLACK	1
34	C00246	WASHER, .5IB, WAVE	2
35	G11943	WHEEL, .5IN SATURN	2
36	C00284	SCREW, 10-32 X .375 GROUND	1
37	C00327-212	SCREW, 10-32 X 2.5 IN FLAT HEAD MACHINE SLOTTED, SS	1
38	C00319	SCREW, .25-20 X 3.5 LG, HEX	1
39	C00233	WASHER, FLAT, .25 IN	1
40	A00073	90 ELBOW, .125FP X .125 PF, BRASS	5
41	A00089-2	SPRAY TIP, 110015 X .125 IN MP	5
42	C00307-38	SCREW, 8-32 X .375 FLATHEAD	4
43	D00417	AXLE, BRUSH, .50 IN CRS, PW18	1
44	C00233-1	WASHER, FLAT, .25 IN, SS	2
45	C00313-58	BOLT, .25-20 X .5 LG, HEX	2
46	C00298-12	SCREW, #10 X .50 IN, PAN HEAD	2
47	D00362	SPACER, .5 IN OD	1
48	C00245	WASHER, .375 IN WAVE	1
49	F00508	BRUSH, 18 IN, PW 18	1
50	G00528	BEARING, 10MM	2
51	G00529	BEARING COVER	2
52	D00408	BRUSH SPACER	2
53	C00307-12	SCREW, 8-32 X .5 FLATHEAD	4
54	D00398-393	PULLEY, .393 DIAMETER	1
55	D00369	RUNNER, 18 IN	2
56	B00190	NYLON TIE, 4 IN	5
57	B00180-10-1	RING TERMINAL, #10 CENTER	1
58	F00496	WINDOW	1
59	H02564-2	LABEL, CAUTION, RISK OF	1
60	A00129	TEE	4
61	A00130	90 DEG. ELBOW, .125 MP X .25 IN BARB, NYLON	1
62	D02370	BRACKET, BRUSH MOTOR	1
63	C02281	HEX NUT, 6-32 NYLON	1
64	B02171	MOUNTING BOARD, RECTIFIER	1
65	C02245	SCREW, 6-32 X .5 IN HEX HEAD, SLOTTED, SELF TAP	1
66	C02280	SCREW, 6-32 X .625 IN, NYLON	1
67	00843A	BRIDGE RECTIFIER	1
68	82538-1A	BRUSH MOTOR, 115VDC	1
69	C00278	LOCKNUT, 10-32 NYLON, SS	2
70	D00398-1	PULLEY, MOTOR	1
71	L00779-2	BELT	1
72	D11482	HANDLE, BRACE, RIGHT, BLACK	1

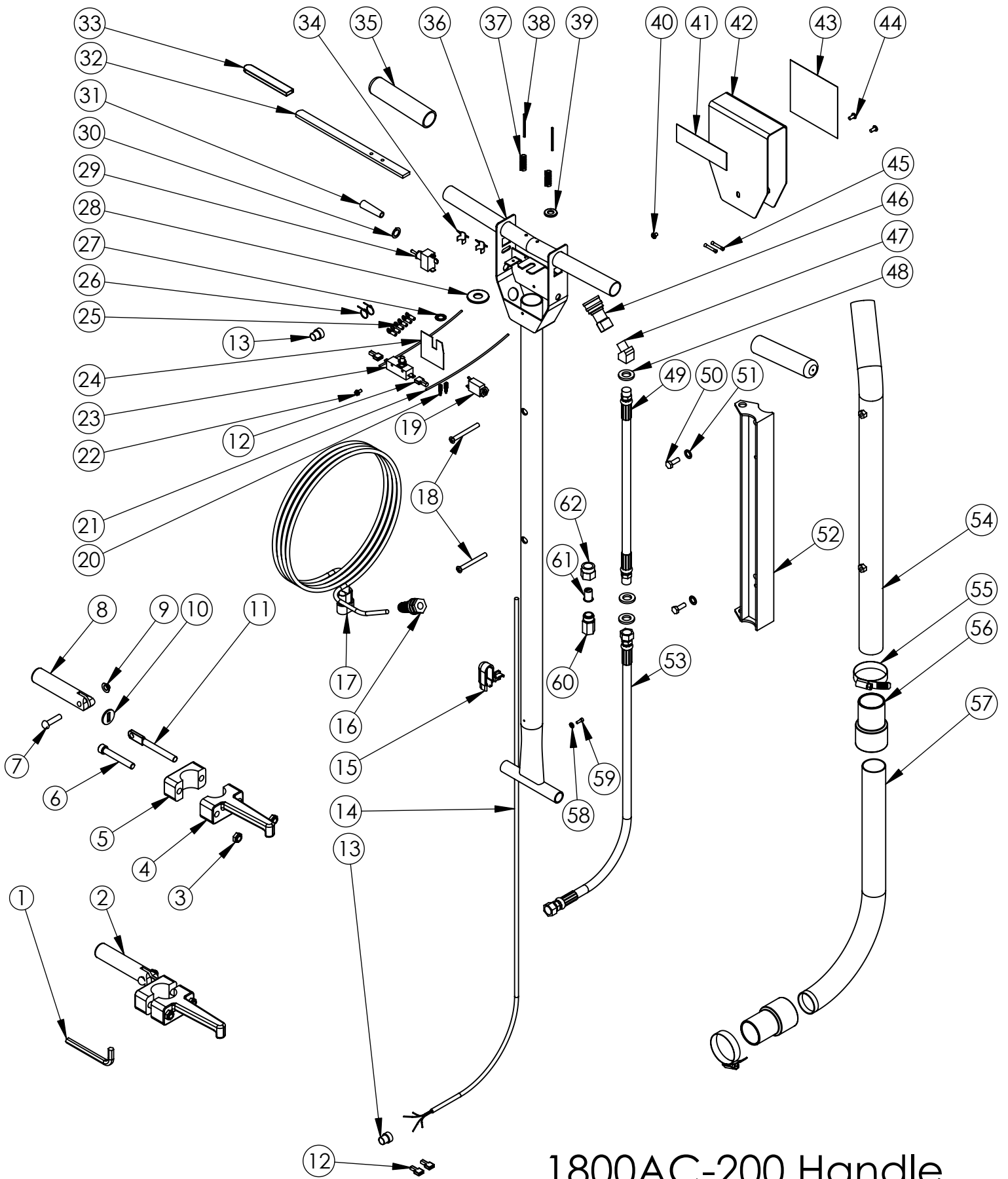

1800AC-200 Handle
3-20-08

1800AC-200 HANDLE

ITEM #	PART #	DESCRIPTION	QTY
1	C11619	ALLEN WRENCH, .31 IN	1
2	11507A	ASSEMBLED LOCKING HANDLE, CORD HOOK	1
3	C11558	LOCKNUT, BLACK OXIDE, THIN	2
4	D11507-2	CORD HOOK BODY	1
5	D11507	CORD HOOK CLAMP	1
6	C11502	SOCKET CAP SCREW, .375-16 X 2.5 IN	1
7	C11537	DOWEL PIN, .31 X 1.5 IN	1
8	D11497	HANDLE, LOCKING CLAMP	1
9	C11538	CAP NUT, .31 IN, PUSH ON	1
10	C00259	WASHER, SLOTTED, ZINC	1
11	C11536	SPADE BOLT, .375-16 X 4 IN	1
12	B00177	TERMINAL LUG, FEMALE, QD, .25 X .032, 16-14 AQG	4
13	B00179-1	CLOSED END CNTR, 16-3	2
14	B00222	CABLE, 18-4 X 44 IN, SJTO	1
15	B10734	STRAIN RELIEF, HANDLE	1
16	B11199	STRAIN RELIEF, PIGTAIL	1
17	B00217-1	POWERCORD, POWERMATE, 25'	1
18	C00323	SCREW, .25-20 X 2.25 IN OVAL HEAD	2
19	B02192	CIRCUIT BREAKER, 3 AMP	1
20	B02199	FEMALE CONNECTOR, .110 FED, FULLY INSULATED	2
21	B00185-41	WIRE, 16 GA BLACK, ULCSA, 600V, -60C TO +200C	2
22	C00284	SCREW, 10-32 X .375 GROUND	1
23	B00209	MOMENTARY MICROSWITCH	1
24	B11518	SWITCH INSULATION	1
25	B00180-10-1	RING TERMINAL, #10 CENTER	6
26	B00190	NYLON TIE, 4 IN	2
27	C11541	WASHER, .375IN, STAR	1
28	C00239	WASHER, .5 IN, FLAT	1
29	B00208	SWITCH, TOGGLE, MOM OFF-ON	1
30	C00249	WASHER, NON- ROTATIONAL	1
31	B00210	TOGGLE LEVER, BLACK	1
32	D00339	PW 18 SOLUTION LEVER	1
33	K00722	SOLUTION GRIP, 1800AC	1
34	D00410-1	CORD CLAMP, 18-3	2
35	K11498	HANDLE GRIP, FLOOR MACHINE	2
36	D11479-1	HANDLE, PW-18	1
37	D00361	SPRING, SWITCH, LEVER, 1800AC	2
38	C00306	ROLL PIN, .125 X 1.75	2
39	C00252	WASHER, .375 IN, FLAT	1
40	C11528	SCREW, 10-32 X .25 IN	1
41	H00556-1	LABEL, EDIC, BLUE & WHITE	1
42	D11496B	SWITCH BOX COVER, BLACK	1
43	H00559	LABEL, INSTRUCTION, 1800AC	1
44	C11529	SCREW, 10-32 X .375 IN	2
45	B00181	WIRE SPLICE, BLUE, 1 WIRE	2
46	A00102	QD, 1-4F X 1-4FP	1
47	A00053	45 ELBOW, .25MP X .25FP	1
48	C00240	WASHER, SHOULDER, NYLON	3
49	00580-15IN-A	HOSE ASSEMBLY, 15 IN X .25 IN, HIGH PRESSURE	1
50	C00313	HEX BOLT, .25-20 X .75IN	2
51	C00254	LOCKWASHER	2
52	D02425	TUBE, BRACKET, PW 18	1
53	00580-24IN-MF-A	HOSE ASSEMBLY, 24 IN X .25 IN, HIGH PRESSURE	1
54	D00354	VACTUBE, PW18, 45 X 1.5IN	1
55	J00650	SCREW CLAMP, #24, 1.25 IN	2
56	J00625	CUFF, 1.5IN, GREY	2
57	J00616-10	VACUUM HOSE, 1.5 X 19 IN	1
58	C02249	LOCKWASHER, #10 INT, STR, SS	1
59	C02328	SCREW, ALLEN HEAD, 10-24 X .375 IN	1
60	A00097B	FILTER, INLINE, BODY	1
61	A00097C	CHECKVALVE, 100 MESH	1
62	A00097A	CAP, INLINE FILTER	1

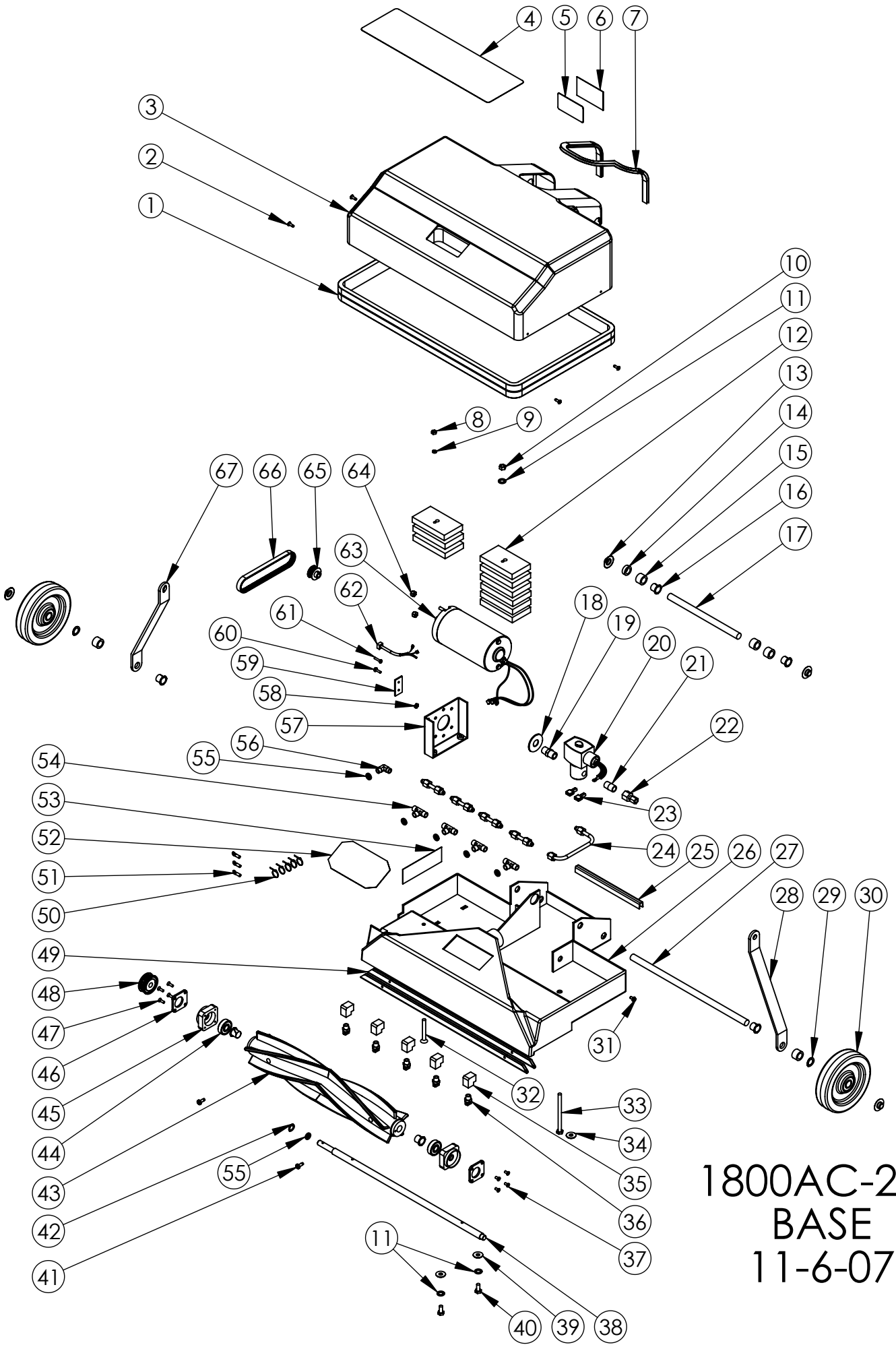

1800AC-200
 BASE
 11-6-07

1800AC-200 BASE

ITEM #	PART #	DESCRIPTION	QTY
1	E00440	BUMPER EXTRUSION, 52 IN	1
2	C00293	SCREW, 50 IN, BLACK	4
3	F00480B	COVER, BLACK	1
4	H00547-12	LABEL, 1800AC	1
5	H00565-5	LABEL, SERIAL NUMBER	1
6	H03545	COVER, SERIAL # LABEL	1
7	E00445-19A	BUMPER, .50 IN X 19IN	1
8	C00264	HEX NUT, 10-32, SS	1
9	C02315	LOCKWASHER, #10 INT, STR, SS	1
10	C00261	NUT, .25-20, HEX	1
11	C00254	LOCKWASHER	3
12	D00356-2	COUNTER-WEIGHT, PW18	9
13	C02305	CAP NUT, .5IN PUSH-ON	4
14	K11561	SPACER, .25LG, NYLON, NATURAL	1
15	K00662-50	SPACER, .50LG, NYLON, NATURAL	5
16	K00674	BUSHING, .50IN, NYLON	6
17	D00418-9	AXLE, HANDLE, .5 X 7.56 IN	1
18	C11244	WASHER	1
19	A12960	SOLENOID	1
20	G00527-1	SOLENOID VALVE, 200 PSI	1
21	A00111	NIPPLE, .25, CLOSE, BRASS	1
22	A00145	.25FP X .25C	1
23	B00177	TERMINAL LUG, FEMALE, QD, .25 X .032, 16-14 AWG	2
24	A00085	COPPER TUBING, .25 IN	1
25	E00445-7A	BUMPER, .50IN X 7IN	1
26	D00404	BRUSH CHAMBER ASSY, 1800AC	1
27	D00418-12	AXLE, WHEEL, .5 X 12.5 IN	1
28	D11481	HANDLE BRACE, LEFT, BLACK	1
29	C00246	WASHER, .5IN, WAVE	2
30	G11943	WHEEL, 5 IN SATURN	2
31	C00284	SCREW, 10-32 X .375 GROUND	1
32	C00327-212	SCREW, 10-32 X 2.5 IN FLAT HEAD MACHINE SLOTTED, SS	1
33	C00319	SCREW, .25-20 X 3.5LG, HEX	1
34	C00233	WASHER, FLAT, .25IN	1
35	A00073	90 ELBOW, .125 FP X .125 PF BRASS	5
36	A00089-2	SPRAY TIP, 110015 X .125 IN MP	5
37	C00307-38	SCREW, 8-32 X .375 FLATHEAD	4
38	D00417	AXLE, BRUSH, .50 IN CRS, PW18	1
39	C00233-1	WASHER, FLAT, .25IN, SS	2
40	C00313-58	BOLT, .25-20 X .5LG, HEX	2
41	C00298-12	SCREW, #10 X .50IN PAN HEAD	2
42	C00245	WASHER, .375IN, WAVE	1
43	F00508	BUSH, 18 IN, PW18	1
44	G00528	BEARING, 10 MM, PW18	2
45	G00529	BEARING COVER, 1800AC	2
46	D00408	BRUSH SPACER, PW18	2
47	C00307-12	SCREW, 8-32 X .5 FLATHEAD	4
48	D00398-393	PULLEY, .393 DIAMETER	1
49	D00369	RUNNER, 18 IN, 1800AC	2
50	B00190	NYLON TIE, 4 IN	5
51	B00180-10-1	RING TERMINAL, #10 CENTER	3
52	F00496	WINDOW, PW 18	1
53	H02564-2	LABEL, CAUTION, RISK OF	1
54	A00143	TEE, .125 MP X .25 C X .25 C	4
55	D00362	SPACER, .5 IN OD	6
56	A00132	90 ELBOW, .125 MP X .25C	1
57	D02370	BRACKET, BRUSH MOTOR, PS	1
58	C02281	HEX NUT, 6-32, NYLON	1
59	B02171	MOUNTING BOARD, RECTIFIER	1
60	C02245	SCREW, 6-32 X .5IN, HEX HEAD, SLOTTED, SELF TAP	1
61	C02280	SCREW, 6-32 X .625 IN, NYLON	1
62	00843A	BRIDGE RECTIFIER	1
63	82538-1A	BRUSH MOTOR, 115VDC	1
64	C00278	LOCKNUT, 10-32, NYLON, SS	2
65	D00398-1	PULLEY, MOTOR	1
66	L00779-2	BELT, 1800AC	1
67	D11482	HANDLE BRACE, RIGHT, BLACK	1