



Electronic Service Manuals

This electronic document is provided as a service to our customers. We do not create the contents of the information contained in this document. Should you have detailed questions pertaining to the information contained in this document, you may contact Michco, or the manufacturer which provided the original information in this electronic deliverable. Michco's only part in this electronic deliverable was the electronic assembly process. By providing this manual online we are not guaranteeing parts availability.

You may contact Michco through the following methods:

Phone (517) 484-9312

2011 N. High St. -- Lansing, Michigan -- 48906

Fax: (517) 484-9836

Email: CustomerService@Michco.com

Website: www.Michco.Com

Order Parts online at:

www.Michco.Com

Directly to Parts & Service:

By Email: **CustomerService@Michco.com**

By Fax: (517) 484-9836

By Voice: (517) 484-9312

Serving the Cleaning Industry Since 1922

Notice: All copyrighted material remains property of original owners, all trademarks are property of respective owners. Manuals are subject to Manufacturer's reproduction limitations. Originals or reproductions were provided by manufacturers through a request. We make no warranty as to the correctness of information provided in this document and you assume all risk. By placing these manuals on line we are not declaring our corporation to be an manufacturer authorized dealer or provider, please check our web site for authorized manufacturers we represent.

GALAXY

2000JX-HR
2000KX-HR

PROFESSIONAL 12 GALLON CARPET EXTRACTOR OWNER'S/OPERATOR'S MANUAL

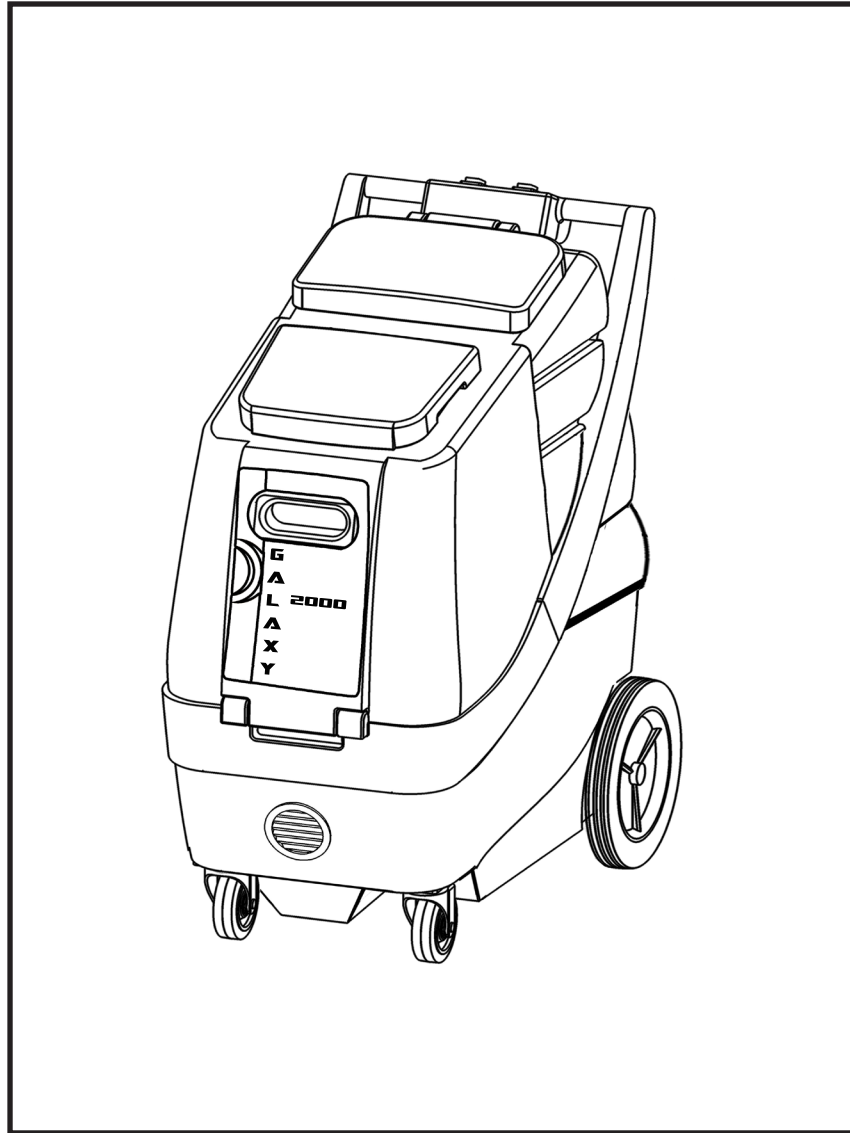

PROUDLY DESIGNED AND MANUFACTURED BY

EDIC

WWW.EDIC-USA.COM

Revised 1-29-18



TABLE OF CONTENTS

RECEIVING YOUR EQUIPMENT.....	3
WARNINGS AND SAFETY.....	3, 4
ELECTRICAL INFORMATION.....	4
GROUNDING INSTRUCTIONS.....	4
MAINTENANCE.....	5
CORD STORAGE AND SAFETY.....	5
MACHINE OVERVIEW.....	6
ACCESSORY HEATER OVERVIEW (OPTIONAL).....	7
PRIMING THE MACHINE.....	8
ADJUSTING PRESSURE.....	8
HOW TO USE AN ACCESSORY HEATER.....	9
CLEANING CARPET.....	10
CLEANING UPHOLSTERY.....	10
WIRING.....	11
UPPER BREAKDOWN 2000JX-HR.....	12, 13
UPPER BREAKDOWN 2000KX-HR.....	14, 15
TROUBLESHOOTING.....	16
NOTES.....	17
WARRANTY INFO.....	18, 19

RECEIVING YOUR NEW 2000JX-HR OR

2000KX-HR: When your package is delivered, check the carton carefully for signs of rough handling. If your 2000JX-HR/2000KX-HR is damaged, notify the carrier immediately and request an inspection. Be sure to keep the carton, packing inserts, packing lists and carrier's receipt until the inspector has verified your claim.

EDIC's liability ceases when the carrier picks up the shipment. However, our customer service staff will be happy to furnish any information needed in connection with the claim and will attempt to expedite a resolution.

**PLEASE READ BEFORE OPERATING YOUR NEW 2000JX-HR/2000KX-HR:**

Read the manual carefully and completely before attempting to operate the unit. This manual has important information for the use and safe operation of the machine. Keep this manual handy at all times.

This equipment has been engineered and manufactured to provide excellent performance and service. To ensure that your equipment will continue to perform as intended:

- Maintain equipment regularly- following the suggested maintenance schedule provided.
- Use only original EDIC parts when servicing.
- Operate equipment with care.

If additional information is needed, please contact:

EDIC
800-338-3342

All information and specifications printed in the manual are current at the time of printing; however because of EDIC's policy of continual product development, we reserve the right to make changes at any time without notice.

FAILURE TO COMPLY WITH THE FOLLOWING WARNINGS AND INSTRUCTIONS WILL VOID THE WARRANTY.**WARNING!**

- The machine was designed for use on carpet cleaning applications as per instructions and recommendations written in this manual. Any deviation from its proper use or purpose and the consequential damage that may occur is the sole responsibility of the end user.
- Disconnect the power cord from the outlet before servicing. Do not leave machine connected to an electrical outlet when unattended.
- Do not immerse or use this machine in standing water. Such use may cause electric shock.
- When using an extension cord, use only a 3-prong conductor grounding cord-12 gauge wire or heavier.
- To avoid electric shock, do not expose the unit to rain or snow. Store it indoors in a heated location only.
- Do not use the machine for dry vacuuming.
- Use defoamer at all times to prevent damage to the vacuum motor.
- Do not use water in excess of 130°F (54°C) in the solution tank
- To prevent seal damage and chemical build-up to the pump system, run clean water through the solution lines after each day's use.
- Use only commercially available carpet cleaning solutions and defoamer intended for use with machines of this type. Do not use dyes, bleaches, ammonia, or other additives.
- The use of powdered cleaning solution, if not diluted properly, may result in damage to the pump. Powdered chemical is not recommended. If powdered chemicals are used, premix in a separate container before placing in the solution tank.
- Always read and understand your chemical's MSDS (Material Safety Data Sheet) before use.
- This equipment is not designed to handle or use combustible/volatile substances such as gasoline or kerosene, in, on, or near the machine. The use of such materials will cause extreme hazardous condition.
- Do not expose machine to freezing temperatures.

- All repairs must be done by an authorized EDIC repair station.
- Do not use replacement parts other than original EDIC parts.
- Do not allow your spray stream to remain in one fixed location as surface damage may occur.
- Check that all spray nozzles are securely fastened. Loose nozzles could be ejected from equipment at high speeds.
- This is not a toy. Keep away from children.
- Do not pull by the power or use power cord as a handle. Always unplug by grabbing the plug and pulling, do not unplug by pulling the power cord.
- Inspect cord for damage. Do not use damaged cords. Connect only to properly grounded outlets.
- Keep hair, fingers, loose clothing, and body parts away from moving parts and openings.
- Turn off all controls before disconnecting machine
- Use caution with ejected liquid or chemicals. High pressures and temperatures could be hazardous to nearby people or surroundings.
- Do not run the heater dry. always make sure you have water
- Do not expose heater to freezing temperatures.
- Prevent burns by wearing gloves or using a barrier to remove hot quick disconnects.
- Never leave heater or equipment unattended when connected or powered on.
- The accessory heater was designed for use on 2000JX-HR/2000KX-HR extractors for carpet, floor and upholstery extraction applications. Any deviation from its proper use or purpose and the consequential damage that may occur is the sole responsibility of the end user.



ELECTRICAL - 115 Volt

Model: 2000JX-HR/2000KX-HR

This machine is designed to operate on a standard 15 amp, 120 volt, 60 Hz, AC circuit. Voltages below 105 volt AC or above 125 volts AC could cause serious damage to the motor.

GROUNDING INSTRUCTIONS FOR 115VOLT:

This piece of equipment must be grounded. Should an electrical malfunction occur, grounding provides a path of least resistance for electrical current- reducing the risk of electric shock. This piece of equipment is furnished with a cord that has a grounding conductor and grounding plug. The grounded plug must only be plugged into an appropriate outlet that is properly installed and grounded in accordance with all local codes and ordinances.

WARNING:

Connecting the equipment to an improperly grounded outlet can result in an increased risk of electric shock. A qualified electrician should be consulted if you are unsure that the outlet is properly grounded. Do not modify the plug provided with the equipment. If it will not fit the outlet, have a proper outlet installed by a qualified electrician.

This appliance is designed for use on a 120-volt circuit. The grounding plug provided looks like the plug illustrated in Figure 1. Replace the power cord if the grounding pin is damaged or broken.

Extension cords connected to this machine should be 12 gauge, three-wire cords with three-prong plugs and outlets. **DO NOT** use extension cords more than 25 feet (7.6 m) long.

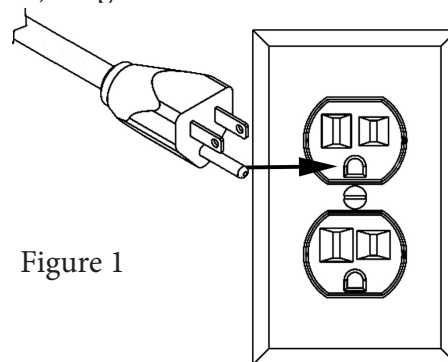

Figure 1

MAINTENANCE:

This 2000JX-HR/2000KX-HR has been engineered and built to require minimum maintenance. But like any machine, it does require basic care to keep it in optimum working condition. Careful attention to these maintenance instructions will give you maximum operating performance and life expectancy of the machine.

CAUTION: Disconnect the power cord from the outlet before doing any clean up or maintenance on the machine

1. Keep the machine clean. Do not allow dust to accumulate on external surfaces or near any moving parts.
2. After every job, wipe down the surface of the machine with a clean damp cloth.
3. Inspect cord for damage. Do not use machine with a damaged cord.

PERIODIC MAINTENANCE

- Use only chemicals safe for extractors
- Adhere to the appropriate mix ratios for all chemicals
- For optimal performance, it is suggested that the operator flush the system after every job or at the end of the day.
- Pump seals and valves may need to be replaced at the 1000 hour mark if a loss in pressure is noted

Daily:

1. Always keep the machine clean inside and out.
2. Pour 2 gallons of clean hot water in the solution tank. Turn the pump on and flush the entire system through the wand nozzles for about a minute to prevent alkaline build-up.
3. Remove dirt and lint build-up inside the filter screen in the recovery tank. Lint should be cleaned off so that air flow is not impeded.
4. Check the solution tank strainer in the solution tank. If lint has accumulated in the screen, remove and rinse it in clear running water.

Weekly:

- Check and clean solution filter
- Check for obstructions in vacuum pathways
- Quarterly:
 - Check pump, plumbing and fittings for leaks
 - Check power cords and hoses for tears

CORD STORAGE:

While not in use, storage can be accomplished by winding cord around handle assy. Cord should be completely unwound during operation.

CORD SAFETY

- Do not leave appliance when plugged in. Unplug from outlet when not in use and before servicing
- Do not use with damaged cord or plug. If appliance is not working as it should, has been dropped, damaged, left outdoors, or dropped into water, return to service center for inspection and repair.
- Do not pull or carry by cord, use cord as handle, close a door on cord, or pull cord around sharp edges or corners. Do not run this 2000JX-HR/2000KX-HR over cord. Keep cord away from heated surfaces.
- Do not unplug by pulling cord. To unplug, grasp the plug, not the cord.
- Do not handle plug or appliance with wet hands.
- This equipment should be stored indoors and not exposed to rain.

2000JX-HR/ 2000KX-HR OVERVIEW

1. Handle- Used to maneuver and position the 2000JX-HR/2000KX-HR. Contains switch box (for switchbox, see #13).
2. Recovery tank and lid- Tank collects recovered waste water. Lid allows access to recovery tank and creates a seal to ensure suction.
3. Solution tank and lid- Tank used to store clean water or solution for your job. Lid allows access to the solution tank and prevents external contamination of solution tank.
4. Non-marking front 4" locking casters and rear 10" wheels.
5. Recovery/vacuum hose inlet barb- connect your recovery vacuum hose to this barb.
6. Male twist lock pigtail- Connects to 50ft power cord. One circuit per cord.
7. Solution line Q.D.- Pressurized connection for solution line.
8. Pressure Gauge
9. Pressure regulator
10. Cool air intake for vacuum.
11. Recovery tank dump valve
12. Heater mounting brackets.
13. Switch box- Two switches marked "VACUUM" and one switch marked "PUMP".

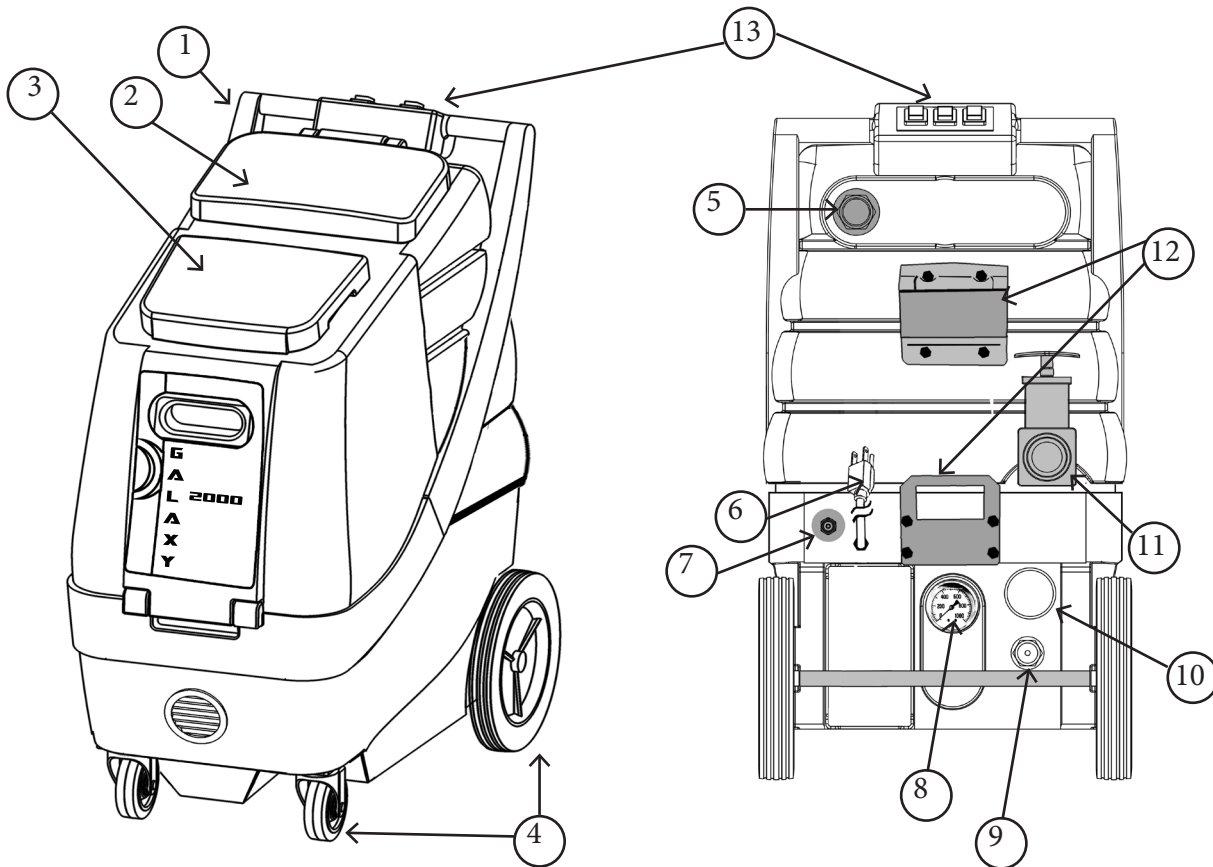

ACCESSORY HEATER KIT 605HR/705HR

OVERVIEW

(PURCHASED SEPARATELY)

1. INLET QUICK DISCONNECT AND HOSE- Connects to machine's outlet.
2. POWER SWITCH.
3. LAMP- Indicates when heat element is on and working.
4. TWIST LOCK PIG-TAIL- This connects to the female twistlock plug on the rear of the 2000JX-HR/2000KX-HR.
5. OUTLET QUICK DISCONNECT- Connects to working solution line.
6. HANDLE- Used to hold and transport the heater
7. MOUNTING FEET- Used to engage the mounting brackets on an 2000JX-HR/2000KX-HR extractor and secure the heater.
8. RESET ACCESS POINT- Allows access to the breaker switch in the event the unit has been run dry.

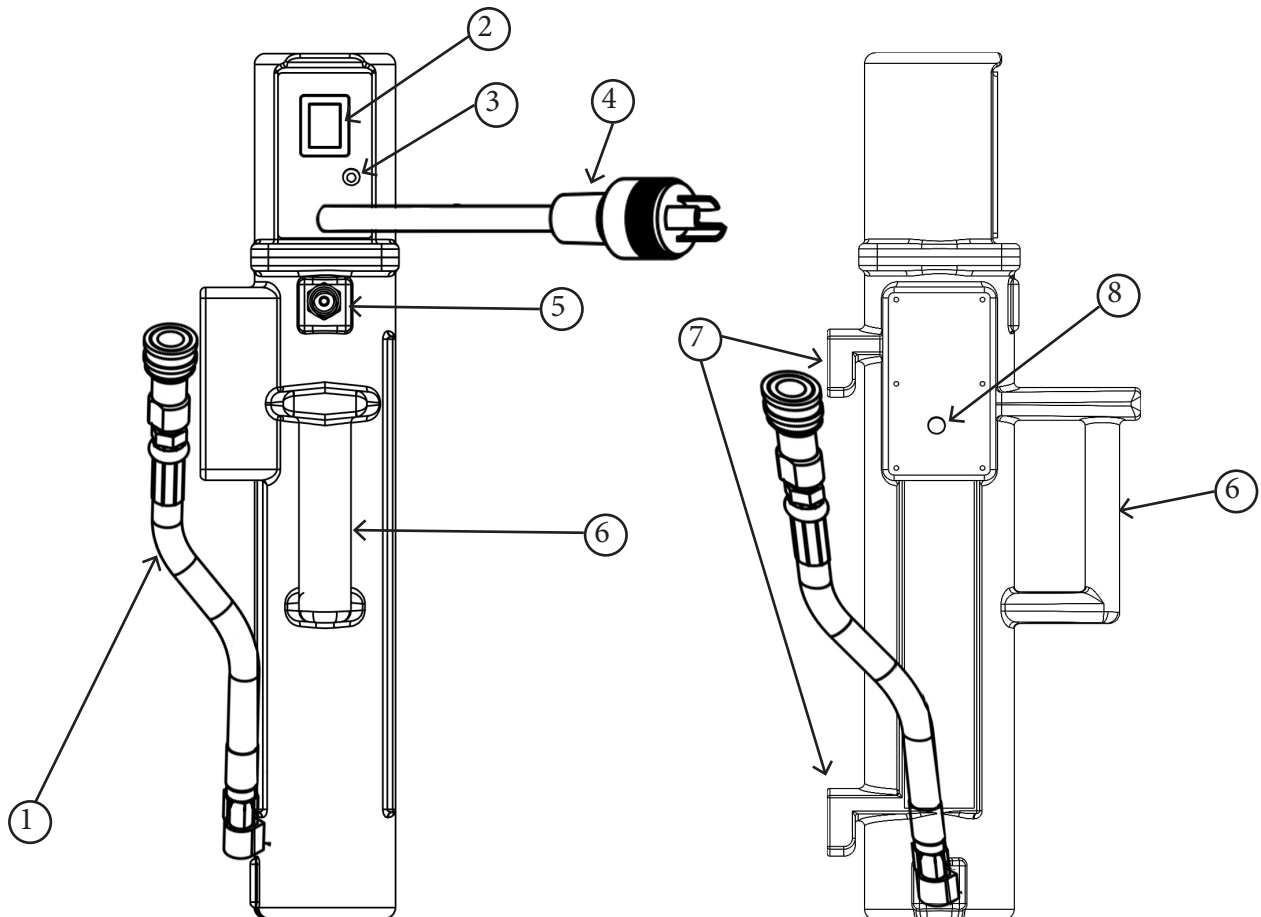

PRIMING THE MACHINE USING THE PRIMING HOSE:

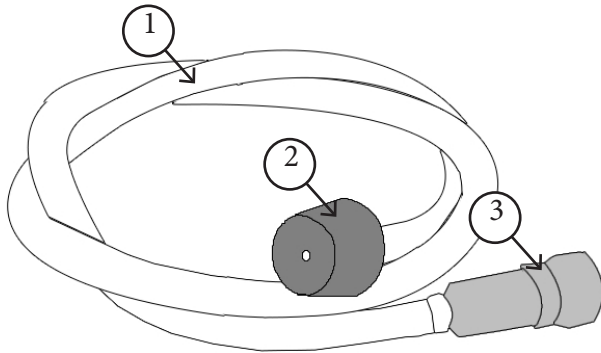

1. Locate your priming hose (pictured above). Your priming hose can be found in the solution tank of your new machine when you first receive it.
2. Make sure that your solution tank has a good amount of water, as this will help the pump prime more easily. (Solution tank is #3 on page 6)
3. Connect the female end (#3 on image above) of your priming hose to the male fitting on your extractor. (#7 on page 6)
4. Hold the plug end (#2 on image above) to the vacuum inlet barb (#5 on page 6).
5. Turn on your pump and vacuums.
6. Let the machine run until you can see bubble free water flowing through the clear priming hose (#1 on image above).
7. Turn off pump and vacuum(s)
8. Your pump is primed and ready to start cleaning.
9. Disconnect priming hose and connect either your heater hose or your 25ft solution hose.

ADJUSTING PRESSURE USING THE PRESSURE REGULATOR:

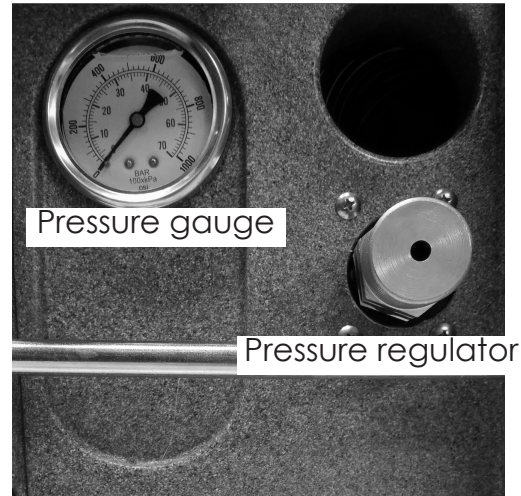

This machine is equipped with a PRESSURE REGULATOR and PRESSURE GAUGE. You may adjust the pressure between 100PSI and 250PSI. The machine has been set to the max pressure at the factory. DO NOT exceed 250PSI. For location of pressure gauge and regulator, see #8 & #9 on page 6.

TO REDUCE PRESSURE:

1. Turn on the pump. Prime, if necessary.
2. DO NOT SPRAY WHILE ADJUSTING.
3. Turn the PRESSURE REGULATOR counter-clockwise and monitor the PRESSURE GAUGE until you have reached the desired Pressure.

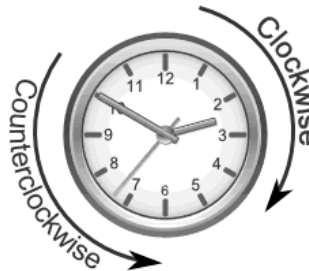

TO INCREASE PRESSURE:

1. Turn on the pump. Prime, if necessary.
2. DO NOT SPRAY WHILE ADJUSTING.
3. Turn the PRESSURE REGULATOR clockwise and monitor the PRESSURE GAUGE until you have reached the desired Pressure.

****WARNING: DO NOT EXCEED 250PSI! MOTOR MAY BECOME DAMAGED.****

How to use an accessory heater:

1. Fill the solution tank of your 2000JX-HR/2000KX-HR extractor with sufficient water or solution for the task at hand. Do not use water over 130 degrees F.
2. Mount the Heater by lining up the two mounting legs (See #7 on page 7) to the two mounting brackets on the rear of the machine (#11 on page 67).



3. Connect your heater's inlet hose (#1 on page 7) to the machine's outlet quick disconnect (#7 on page 6).



4. Connect your 25ft solution hose to the heater's Q.D. (#5 on page 7)



5. Connect your 50FT power cord to the twist lock pigtail on the heater (#4 on page 7). Plug the 50ft power cord(s) to the twist lock pigtail on the back of the machine (#6 on page 6)



6. Connect both 50ft power cords to two separate 15 amp outlets.
7. Connect your 25ft vacuum hose to the extractor's vacuum inlet barb (#5 on page 6)
8. Connect your vacuum and solution line to a carpet wand or upholstery attachment.
9. COMPLETE THIS STEP BEFORE TURNING HEATER ON: Turn the pump switch to the "ON" position using the pump switch on the handle of your 2000JX-HR/2000KX-HR. Pressing the solution valve trigger of your attachment, spray water for 10-15 seconds until you have a steady flow. This ensures the heater is filled with fluid.
10. Turn heater on using the power switch (#2 on page 7) and allow up to 3 minutes for the unit to heat up.
11. The heater is ready for use once the green lamp (#3 on page 7) shuts off. Once you start cleaning, the green lamp will turn on and off throughout your job as the thermostats automatically regulate the temperature.

****WARNING: TO PREVENT IRREPARABLE DAMAGE, DO NOT EXPOSE HEATER OR MACHINE TO FREEZING TEMPERATURES. ****

CLEANING CARPET:

1. Using a dedicated dry vacuum, pre-vacuum the space to be cleaned to remove as much dirt as possible. Do not use the extractor to dry vacuum as it does not have a dry filter.
2. Pre-spray the carpet
3. If using a heater, please see steps 1-11 in section “How to use an accessory heater”
4. Make sure the drain valve (#10 on page 6) is closed by pushing the T-handle all the way in.
5. Always use de-foamer- Previously shampooed carpets usually have a heavy build-up of old shampoo residue which can cause the vacuum system to ingest foam and result in damage to the vacuum motor.
6. With the vacuum and pump switches in the “ON” position, slowly pull the tool towards you with the solution valve trigger pressed. Make a dry pass forward and backward over the cleaned area to recover residual dirt and solution.
7. Do not overwet carpet! Make overlapping passes to prevent streaking.
8. If the carpet is heavily soiled, squeeze solution valve trigger on the forward pass as well as backwards, allowing cleaning solution a few seconds longer to work prior to vacuuming. Another method is to raise the wand 8” above the carpet and pre-spray lightly prior to cleaning passes. On extremely soiled carpets, we recommend using a pre-spray solution.
9. When you are close to running out of solution, turn off the pump and the heater. Attach the drain elbow on the drain valve. Place a pail under the downspout and pull up the drain valve T-handle. Dirty solution will pour out until the tank is empty. Close the drain valve. Use a clean bucket when you refill the solution tank so you do not create contamination.
10. When the job is completed, turn the switches off, including the heater, and disconnect the vacuum and solution hoses from the carpet tool and the machine. Drain the recovery tank through the drain valve as before.

CLEANING UPHOLSTERY:

Cleaning upholstery with success requires a good knowledge of the type of fabric to be worked on. Look for the cleaning instruction label sewn on the underside of the furniture for the recommended method of cleaning the fabric. If it calls for dry cleaning, do not attempt to clean with the wet extraction method. Otherwise, damage to the fabric could occur. Extraction works perfectly on most synthetic fabrics including synthetic velvets.

Before proceeding, test the fabric for colourfastness. Apply a small amount of ready-to-use cleaning solution on the fabric in an inconspicuous spot. Wait for 2 to 3 minutes and rub the area with a white terry cloth towel. If no color comes off the towel, the fabric should be safe to clean. If a little color comes off, there is some risk of colors running when you clean. It may be possible to stabilise colors by cleaning with an acidic rinse.

1. Using a dedicated dry vacuum, pre-vacuum the space to be cleaned to remove as much dirt as possible. Do not use the extractor to dry vacuum as it does not have a dry filter.
2. See steps 1-11 in section “How to use an accessory heater”
3. Make sure the drain valve (#10 on page 6) is closed by pushing the T-handle all the way in.
4. Attach an upholstery tool to the hose set.
5. Always use de-foamer. Previously cleaned upholstery may have a heavy build-up of old shampoo residue which can cause the vacuum system to ingest foam and result in damage to the vacuum motor.
6. With the vacuum and pump switches in the “ON” position, slowly pull the tool backward with the solution valve trigger pressed. Make a dry pass forward and backward over the cleaned area to recover residual dirt and solution.
7. Clean using as little solution as possible. Do not overwet the upholstery! Make overlapping passes to prevent streaking.
8. On heavily soiled areas like arm rests, pre-treat with a recommended pre-spray and /or hold the upholstery tool a few inches above the fabric and press lever to spray on the solution before making a pass.

WIRING DIAGRAM

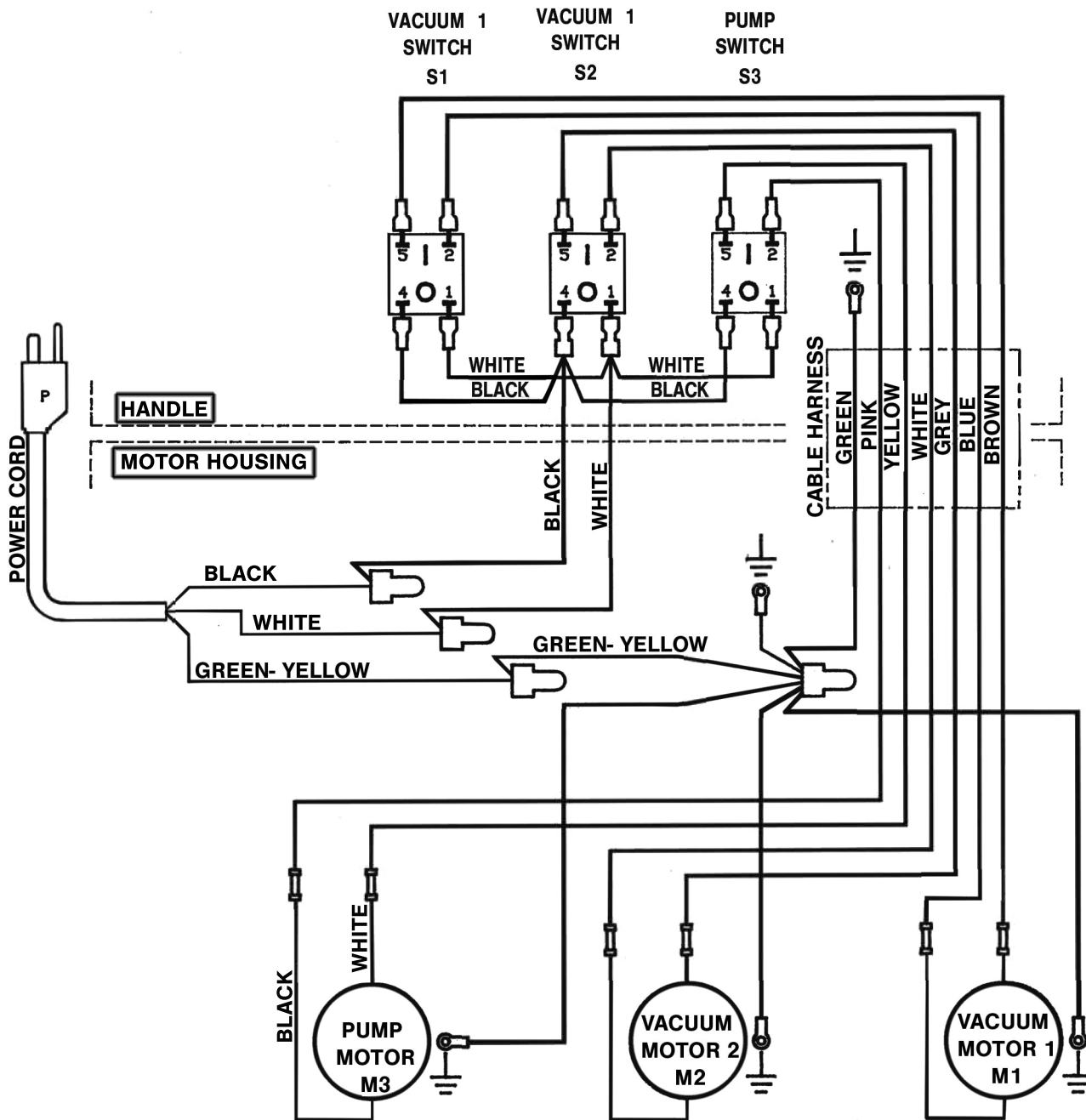

FOR THE FOLLOWING GALAXY AND GALAXY PRO MODELS: SX, SX-HR, IX-HR, JX-HR, KX-HR

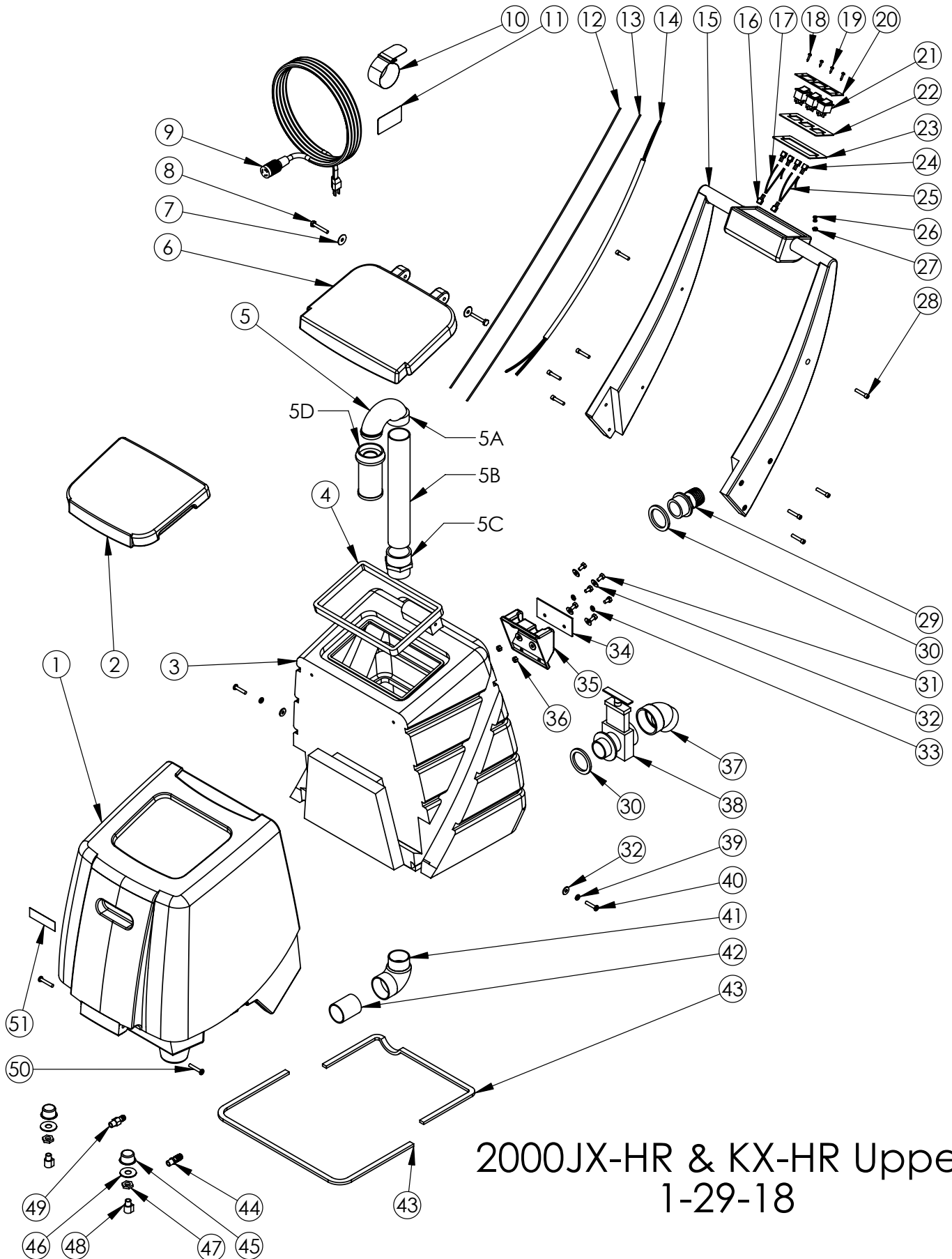

2000JX-HR & KX-HR Upper
1-29-18

2000JX-HR & KX-HR Upper 1-29-18

ITEM NO.	PART NUMBER	QTY.
1	F11787 Solution Tank	1
2	F11791 Lid, Solution Tank	1
3	F11788 Recovery Tank	1
4	E11124 Gasket, Recovery Tank	1
5	12904A Stand Pipe Assembly	1
5A	K11965 Elbow, 180 Deg. Float Ball	1
5B	K00672 Pvc Pipe, 1.5 X 12 in, Sch 40 Wht	1
5C	10989-2A Float Ball Screen	1
5D	K00741 Adapter	1
6	F11785 Lid, Recovery Tank	1
7	C12039 Washer, 1-4 X 1, SS	2
8	C02322 1-4 X 20 Bolt	2
9	B11769 Extension Cord, 12-3 SJTW	1
10	C11177 Velcro Strap	1
11	H02548-2 Label, Important, Cord	1
12	B00185-30 Wires, 73 in	1
13	B00185-40 Wires, 73 in	1
14	B010314 Wire Harness	1
15	F11786 Handle	1
16	B00177 Terminal Lug, Female, QD, .25 X .032, 16-14 AWG, Fully Insulated	2
17	B00185-40 Wire, 14 GA Black, UL1015, 10 in	1
18	C00295-1 #10 X .75in Pan, Black SMS, Phillips	2
19	C00293 #8 X .5in Pan, Black SMS, Phillips	2
20	D11168 Cover, Switchplate, Galaxy	1
21	B02211-1 Switch, Rocker, Green Light	3
22	D010284 Switchplate	1
23	E010453 Gasket, Switchplate	1
24	B00177-1 Terminal Lug, Female, QD, .25 X .032	4
25	B00185-30 Wire, 14 GA White, UL1015, 10 in	1
26	C02315 Lockwasher, #10 Int. Str, SS	2
27	C00264 Nut, 10-32	1
28	C11141 Screw, Allen Head, 10-24 X 1.25 in	8
29	K00665-1 Hose Adapter, 1.5in, Black	1
30	E11128 Gasket, Drain Valve	2
31	C00313 Hex Bolt, 1-4 X 20 X .5 SS	6
32	C00233 Washer, Flat, .25 in	8
33	C02312 Lockwasher, .25 in., Internal Star	2
34	D010283 Plate, Heater Mounting	1
35	F11804 Heater Mount	1
36	C00261 Nut, .25-20, Hex	2
37	K00710 Elbow, Drain Valve, Black	1
38	K00711 Drain Valve, Black	1
39	C00254 Lock Washer, 1-4in Split	2
40	C02294 Screw, 1-4 20 X 1.25	2
41	K11185 Elbow, 90, 1.5 in, MT-MS, PVC	1
42	K00672-1 Pvc Pipe, 1.5 X 2.25 in, Sch 40 Wht	1
43	E11129 Gasket, 5 ft. Long	1
44	A90004 .50 Barb X .25 MP, Brass	1
45	D00373 Inlet Filter, .25 NPT	2
46	C11244 Washer, .56 X 1.5 X .05	2
47	A00124 Hex Nut, .25 NPT Brass	2
48	A00052 90 Elbow, .25MP X .25FP	2
49	A00060 3-8 Barb X 1-4MP, Brass	1
50	C11143 Screw, 1-4 20 X 1.5 in, SS Pan Head, Phillips	2
51	S11179 Non-Skid Tape, 1 in. Roll	1

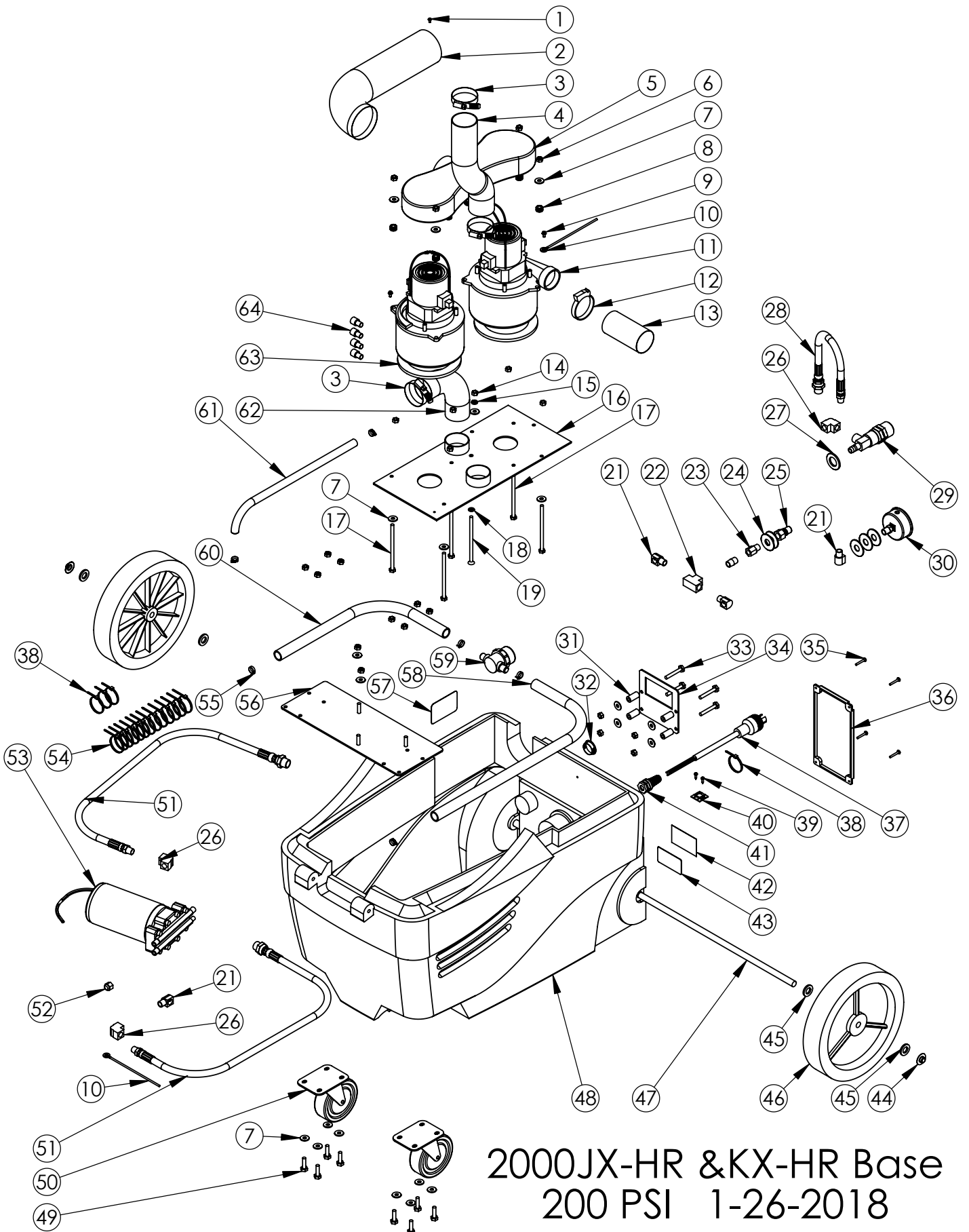

2000JX-HR & KX-HR Base
200 PSI 1-26-2018

2000JX-HR & KX-HR Base 200 PSI 1-26-18

ITEM NO.	2000JX-HR PART NUMBER	2000KX-HR PART NUMBER	QTY.
1	C00297 #8 X .25 Pan Head		1
2	J11863 Hose, 3 in		1
3	J00639 Screw Clamp, 1.63 - 2.43in.		3
4	J00618 Vacuum Hose, 2in Grey, Wire, 22 in lg		1
5	F11178-BLK Intercooler, Galaxy, Black		1
6	C00273 Locknut, 1-4 X 20, Nylon, SS		16
7	C00233 Washer, Flat, .25 in		26
8	E00449 Grommet		6
9	C00284 Screw, 10-32 X .375 Ground		2
10	B11150 Ground Wire, Galaxy		2
11	G00537 Vacuum, 115 V, 5.7 in	G13394 Vacuum, 115 V, 5.7 in	2
12	J00657 Hose Clamp, 2 inSLDPRT		1
13	J00618 Vacuum Hose, 2 in Grey, Wire, 4 in lg		1
14	C00261 Nut, .25-20, Hex		10
15	C00254 Lock Washer, 1-4in Split		1
16	D11134 Vac Plate		1
17	C11189 Screw, 1-4 X 20 X 4.5 in, Hex		5
18	C02312 Lockwasher, .25 in., Internal Star		1
19	C11516 Screw, 1-4 X 20 X 4.5 in, Flat Head, Phillips		1
20	A00111 Nipple, .25 in		1
21	A00052 90 Elbow, .25MP X .25FP		4
22	A00161 Tee, .25 FP, Brass		1
23	A00121 Fitting, .25 MP X .25 FP, Brass		1
24	C11244 Washer, .56 X 1.5 X .05		5
25	A00104 QD, 1-4 M X 1-4 FP, Brass		1
26	A00154 90 Elbow, .25 NPT X .25 NPT		3
27	C11560 Washer, .93 ID X 1.5 OD		1
28	00580-13in-MF-A Hose Asm, 13 in X .25HP		1
29	G13133 Valve, Regulator, 200 PSI		1
30	G00516-3 Gauge, 0-600PSI		1
31	C11440 Spacer, Heater Mounting Plate		4
32	K10510 Plug, 1.25 in, Black		1
33	C02322 Hex Bolt, 1-4 X 20 X 1.75 in		4
34	D010379 Heater Mounting Plate		1
35	C11165, Screw, #8 X 1 in, Pan, Black		4
36	F11790 Heater, Tunnel Cover, Blue Granite		1
37	B11779 Stub, 12-3 SJTW Yellow		1
38	B00191 Nylon Tie, 11in Black		4
39	C00293 #8 X .5in Pan, Black SMS, Phillips		2
40	B00192 Tie Holder with Glue		1
41	B11606 Strain Relief, Pigtail		1
42	H03545 Cover, Serial # Label		1
43	H00565-5 Label, Serial Number		1
44	C02305 Cap Nut, .5in Push-on		2
45	C00240 Washer, Shoulder, Nylon		4
46	G11767 Wheel, 10 in		2
47	D11170 Axle		1
48	F11789 Base		1
49	C00314-1 Hex Bolt, 1-4 X 20 X 1in		8
50	G03518 Caster, 4 in		2
51	J00632-1 Pulse Hose, Pump - QD, 42 in		2
52	A13140 Cap, FPT, .375 Brass		1
53	G13132 Pump, 200 PSI, 120 V		1
54	B00190 Nylon Tie, 4in		13
55	J11508 Screw Clamp #6, .43 to .875 in		6
56	D13103 Plate, Pump, Galaxy, Flat		1
57	H02564-2 Label, Caution, Motor Housing		1
58	J11933 Hose, .5 in Polywire, 20 in		1
59	K11935 Strainer, Inline, .5 in		1
60	J11933 Hose, .5 in Polywire, 33 in		1
61	J11154 Solution Hose, .375, 100PSI, Wire, 27 in lg		1
62	J00618 Vacuum Hose, 2 in Grey, Wire, 7 in lg		1
63	E11169 Gasket, Vac Motor, Galaxy		2
64	B00179-2 Closed End Cntr, 16-3		4

TROUBLESHOOTING

ELECTRICAL SYSTEM

PROBLEM	SOLUTION
NO ELECTRICAL POWER	<ol style="list-style-type: none"> 1. Defective power cord. 2. House or building circuit breaker tripped
POWER IS INTERMITTENT TO ONE OR ALL MOTORS	<ol style="list-style-type: none"> 1. Faulty electrical cable. 2. Defective switches. 3. Loose terminal or discolored terminal connections.

VACUUM SYSTEM

PROBLEM	SOLUTION
NO VACUUM SUCTION	<ol style="list-style-type: none"> 1. Drain Valve open. 2. Vacuum lid is not sealed against tank. 3. Loose vacuum hose, vacuum connection
LOW VACUUM SUCTION	<ol style="list-style-type: none"> 1. Accumulated dirt on intake filter screen. 2. Worn out vacuum lid gasket. 3. Lint & dirt build-up on wand head. 4. Defective vacuum hose. 5. Loose connection in the vacuum motor.

SOLUTION SYSTEM

PROBLEM	SOLUTION
PUMP MOTOR RUNS BUT NO SPRAY THROUGH SPRAY TIPS	<ol style="list-style-type: none"> 1. Clogged spray tips. 2. Clogged solution intake filter screen. 3. Clogged female quick disconnect coupler. 4. Quick disconnects not fully connected 5. Dirty or damaged pump head valves. 6. Defective pump check valve. 7. Crack in pump housing. 8. Lost Prime.
UNEVEN OR WEAK SPRAY FOR SPRAY TIPS	<ol style="list-style-type: none"> 1. Clogged or dirty spray tips. 2. Accumulated dirt on solution intake filter screen. 3. Accumulation of debris inside pump and plumbing. 4. Worn pump bearing (excessive noise). 5. Punctured pump diaphragm. 6. Defective rectifier or motor. 7. Worn nozzles. 8. Priming valve is open. Close Pressure relief/priming valve
ERRATIC PRESSURE	<ol style="list-style-type: none"> 1. Pump check valves defective or dirty 2. Lost prime.

NOTES



Quality Above All

Warranty Registration:

To register your product warranty, visit our website at:

www.edic-usa.com/warranty-registration/

EDIC STANDARD LIMITED WARRANTY PLAN FOR MACHINES MANUFACTURED AFTER 2/14/2017

The following Limited 5-year Warranty is given by EDIC with respect to the following specific EDIC products:

Polaris	Aviator	Saturn Low Speed	Aqua Dri
Galaxy 5	Fivestar	Saturn Dual Speed	CR2 Restroom Cleaner
Endeavor	Galaxy	Saturn HD Low Speed	
Heat N Run	Bravo	Atlas	
Saturn High Speed	Supernova	Galaxy Pro	

The following Warranty is given by EDIC with respect to the following specific EDIC products:

2 Years Parts & Labor	TORO HD Orbital	TORO Orbital
FloodBuster Dynamo Vacuums Pilot Autoscrubber Galaxy Automotive Extractors	1725-TES has a 4-year parts warranty and a 2-year labor warranty	1725-TPT has a 2-year parts warranty and a 1-year labor warranty

LIFETIME on rotationally molded polyethylene tanks, stainless steel heater tank and Saturn stainless steel brush covers.

5 YEARS on service labor, and all other parts not covered by the Lifetime terms.

2 YEARS on service labor, and all other parts not covered by the Lifetime terms.

EDIC REPLACEMENT PARTS LIMITED WARRANTY PLAN

All parts sold as replacement parts for out-of-warranty EDIC products have the following Limited Warranty, with no warranty on labor: **30 DAYS**

Your product is warranted to be free of defects in material and workmanship for the period set forth above, after the date of delivery to the retail purchaser, when operated in normal service and used in accordance with the operating and maintenance instructions in the Owner’s Manual. This warranty is limited to and provides at no cost to the retail purchaser repair or replacement of parts determined to be defective, at EDIC’s option, and labor, if provided for above, to replace or repair the parts (“service labor”) according to EDIC’s Standard Rates, during the warranty period set forth above. This warranty excludes transportation charges unless authorized in writing by EDIC. No warranty returns for refund or credit will be permitted. In the event of a defect, these are your exclusive remedies. Warranty claims must be made in writing to EDIC prior to returning the product and no products will be accepted for repair or replacement without prior authorization by EDIC. Use of parts not approved by EDIC in EDIC products will void this warranty. Warranty repair or replacement shall not extend the original warranty period of the product, and replacement parts used for in-



Quality Above All

warranty repairs will only be warranted for the remainder of the original warranty and not from their installation date. Any parts or product replaced under this Limited Warranty will become the property of EDIC.

EXCEPTIONS AND EXCLUSIONS FROM THE WARRANTY. This Limited Warranty only covers product issues caused by defects in material or workmanship during normal service. It does not cover product issues from any other cause, including but not limited to (a) transportation damages; (b) alteration by unauthorized persons; (c) unauthorized use, unreasonable use, misuse, or abuse (including the use of incompatible or corrosive chemicals or overloading of capacity); (d) failure caused by lack of proper maintenance and cleaning; (e) normal wear on items such as cords, belts, hoses, switches, bumpers, gaskets, seals, carbon brushes, squeegees, harnesses, valves, cams, extraction brushes, bearings, handle grips, filters and finishes; (f) acts of God; or (g) modification of or any part of the product. This Limited Warranty does not cover EDIC products sold AS IS and WITH ALL FAULTS. This Limited Warranty is valid only in the United States and Canada.

We suggest that you complete and return the enclosed product registration card promptly to facilitate verification of the date of the original purchase. However, return of the product registration card does not eliminate the need for the retail purchaser to maintain the original proof of the purchase in order to obtain the warranty benefits. In the event that you do not have proof of purchase date, the purchase date for purposes of this warranty will be the date of manufacture.

For specific information on how to obtain warranty services for your product, please write to:

EDIC/Warranty Department
1753 Blake Ave.
Los Angeles, CA 90031

THERE ARE NO WARRANTIES WHICH EXTEND BEYOND THE DESCRIPTION ON THE FACE OF THIS STATEMENT. THERE IS NO IMPLIED WARRANTY OF MERCHANTABILITY OR FITNESS FOR ANY USE ON THESE GOODS.

NO IMPLIED WARRANTY, INCLUDING ANY IMPLIED WARRANTY OF MERCHANTABILITY OR FITNESS FOR A PARTICULAR PURPOSE, APPLIES TO THE PRODUCT AFTER THE APPLICABLE PERIOD OF THE EXPRESS LIMITED WARRANTY STATED ABOVE, AND NO OTHER EXPRESS WARRANTY, EXCEPT AS MENTIONED ABOVE, GIVEN BY ANY PERSON OR ENTITY WITH RESPECT TO THE PRODUCT SHALL BIND EDIC. EDIC SHALL NOT BE LIABLE FOR ANY FORM OF ACTION FOR ANY DAMAGES, WHETHER DIRECT, SPECIAL, INCIDENTAL, CONSEQUENTIAL, OR INDIRECT, TO PROPERTY OR PERSON, INCLUDING BUT NOT LIMITED TO, DAMAGE OR LOSS OF INCOME, LOSS OF PRODUCTION, OR LOSS OF PROFITS DUE TO MALFUNCTIONING OF ANY PRODUCT, REGARDLESS OF THE LEGAL THEORY ON WHICH THE CLAIM IS BASED. IN NO EVENT SHALL RECOVERY OF ANY KIND AGAINST EDIC BE GREATER IN AMOUNT THAN THE PURCHASE PRICE OF THE PRODUCT SOLD BY EDIC, AND CAUSING THE ALLEGED DAMAGE. WITHOUT LIMITING THE FOREGOING, YOU ASSUME ALL THE RISK AND LIABILITY FOR LOSS, DAMAGE OR INJURY TO YOU AND YOUR PROPERTY AND TO OTHERS AND THEIR PROPERTY ARISING OUT OF USE OR MISUSE OF, OR INABILITY TO USE, THE PRODUCT NOT CAUSED DIRECTLY BY NEGLIGENCE OF EDIC. THIS LIMITED WARRANTY STATES YOUR EXCLUSIVE REMEDY.

Some states do not allow the exclusion or limitation of incidental or consequential damages, or allow limitations on how long an implied warranty lasts, so the above limitations or exclusions may not apply to you. This Limited Warranty gives you specific legal rights and you may have other rights which vary from state to state (or province).

0900.002/9989