



## Electronic Service Manuals

This electronic document is provided as a service to our customers. We do not create the contents of the information contained in this document. Should you have detailed questions pertaining to the information contained in this document, you may contact Michco, or the manufacturer which provided the original information in this electronic deliverable. Michco's only part in this electronic deliverable was the electronic assembly process. By providing this manual on line we are not guaranteeing parts availability.

You may contact Michco through the following methods:

Phone (517) 484-9312 or (800) 331-3339

2011 N. High St. -- Lansing, Michigan -- 48906

Fax: (517) 484-9836

Email: [CustServe@Michco.com](mailto:CustServe@Michco.com)

Web site: [www.Michco.Com](http://www.Michco.Com)

Parts Web site: [www.FloorMachineParts.Com](http://www.FloorMachineParts.Com)

Order Parts on Line at:

**[www.FloorMachineParts.Com](http://www.FloorMachineParts.Com)**

Directly to Parts & Service:

By Email: **[Shop@Michco.com](mailto:Shop@Michco.com)**

By Fax: (517) 702-2041

By Voice: Use numbers above.

**Serving the Cleaning Industry Since 1922**

Notice: All copyrighted material remains property of original owners, all trademarks are property of respective owners. Manuals are subject to Manufacturer's reproduction limitations. Originals or reproductions were provided by manufacturers through a request. We make no warranty as to the correctness of information provided in this document and you assume all risk. By placing these manuals on line we are not declaring our corporation to be an manufacturer authorized dealer or provider, please check our web site for authorized manufacturers we represent.



# **Operator's Manual**

# **STV-20 STV-20D**

## **READ THIS BOOK**

This book has important information for the use and safe operation of this machine. Failure to read this book prior to operating or attempting any service or maintenance procedure to your ALTO machine could result in injury to you or to other personnel; damage to the machine or to other property could occur as well. You must have training in the operation of this machine before using it. If you cannot read English, have this manual explained fully before attempting to operate this machine.

All directions given in this book are as seen from the operator's position at the rear of the machine.

For new books write to: ALTO U. S. Inc., 2100 Highway 265, Springdale, Arkansas 72764.

## Contents of this Book



Operator Safety Instructions .....	3
120V Instructions - Power Supply & Electrical Ground .....	4
230V Instructions - Power Supply & Electrical Ground .....	5
STV-20 Single Motor Head Assembly .....	6
STV-20 Dual Motor Head Assembly .....	7
Filter Bag and Float Assembly .....	8
Wet Vac Tools Parts List .....	8
Tank Assembly & Tilt & Pour Carriage Assembly .....	9
Squeegee Tool and Floor Brush Tool Parts List .....	10

# OPERATOR SAFETY INSTRUCTIONS

 **WARNING**

 **AVERTISSEMENT**

 **ADVERTENCIA**

-  **DANGER:** Failure to read and observe all **DANGER** statements could result in severe bodily injury or death. Read and observe all **DANGER** statements found in your Owner's Manual and on your machine.
-  **WARNING:** Failure to read and observe all **WARNING** statements could result in injury to you or to other personnel; property damage could occur as well. Read and observe all **WARNING** statements found in your Owner's Manual and on your machine.
-  **CAUTION:** Failure to read and observe all **CAUTION** statements could result in damage to the machine or to other property. Read and observe all **CAUTION** statements found in your Owner's Manual and on your machine.

 **DANGER:** Failure to read the Owner's Manual prior to operating or attempting any service or maintenance procedure to your ALTO machine could result in injury to you or to other personnel; damage to the machine or to other property could occur as well. You must have training in the operation of this machine before using it. If you or your operator(s) cannot read English, have this manual explained fully before attempting to operate this machine.

 **DANGER:** Operating a machine that is not completely or fully assembled could result in injury or property damage. Do not operate this machine until it is completely assembled. Inspect the machine carefully before operation. Use only as described in this manual. Use only Clarke's recommended attachments.

 **DANGER:** Machines can cause an explosion when operated near flammable materials and vapors. Do not use this machine with or near fuels, grain dust, solvents, thinners, or other flammable materials.

 **DANGER:** Using a machine with a damaged power cord could result in an electrocution. Do not use the machine if the power cord is damaged. Do not use the electrical cord to move the machine. Keep cord away from heated surfaces. Do not unplug by pulling on the cord; grasp the plug not the cord.

 **DANGER:** Electrocution could occur if maintenance and repairs are performed on a unit that is not properly disconnected from the power source. Disconnect the power supply before attempting any maintenance or service.

 **WARNING:** Operating a machine without observing all labels, decals, etc., could result in injury or damage. Read all machine labels before attempting to operate the machine. Make sure all of the labels are attached or fastened to the machine. Get replacement labels and decals from your Clarke distributor.

 **WARNING:** Electrical components can "short-out" if exposed to water or moisture. Keep the electrical components of the machine dry. Always store the machine in a dry building.

 **WARNING:** Use of this machine to move other objects or to climb on could result in injury to the operator or damage to the machine. Do not use this machine as a step or furniture. Do not allow to be used as a toy. Close attention is necessary when used by or near children.

 **WARNING:** Moving parts of this machine can cause injury and/or damage. Keep hands, feet, loose clothing, hair, fingers, and all parts of the body away from openings and moving parts.

- ⚠ WARNING:** Electrocutation could occur if you handle the plug or appliance with wet hands. Do not handle plug or appliance with wet hands.
- ⚠ WARNING:** Damage could occur to machine if openings are blocked. Do not put any object into openings. Do not use with any opening blocked; keep free of dust, lint, hair, and anything that may reduce air flow.
- ⚠ WARNING:** Injury could occur to the operator or the machine if used without the dust bag and/or filters. Do not use the machine without the dust bag and/or filters in place.
- ⚠ WARNING:** Injury to the operator and/or damage to the machine could occur when cleaning on stairs, unless extra caution is used. Use extra caution when cleaning on stairs.
- ⚠ WARNING:** To prevent possible electrical shock, always use a 3-wire electrical system connected to the electrical ground. See "Grounding Instructions".
- ⚠ WARNING:** To reduce the risk of fire, electric shock, or injury:
  - Do not leave appliance when plugged in. Unplug from outlet when not in use and before servicing.
  - Do not pick up anything that is burning or smoking, such as cigarettes, matches, or hot ashes.
  - Turn off all controls before unplugging.

**120 Volt Machine  
Instructions For Connection  
To The Power Supply  
And The Electrical Ground**

This machine must be connected to the electrical ground to protect the operator from electric shock. The machine has an approved power cord with three conductors and a plug with three terminals. Connect the plug to a receptacle that has three holes and is connected to the electrical ground. The green (or green and yellow) conductor in the cord is the ground wire. Never connect this wire to any terminal other than the ground terminal.

This machine uses a 120 volt AC 60 cycle electrical circuit. Make sure you have the correct frequency and voltage before connecting the power cord to an outlet. The machine has a plug as shown in Figure 1. If a receptacle connected to the electrical ground as shown in Figure 1 is not available, have one installed by an electrical contractor. Do not use an adapter.

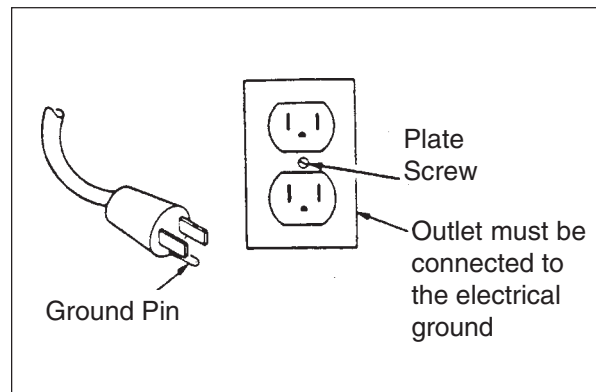

**Figure 1**

- ⚠ WARNING:** To prevent possible electric shock, protect the machine from rain. Keep the machine in a dry building.
- ⚠ WARNING:** To prevent possible electric shock, always use a 3-wire electrical system connected to the electrical ground.
- ⚠ WARNING:** Do not cut, remove or break the ground pin. If the outlet does not fit the plug, consult your electrical contractor.
- ⚠ WARNING:** Have worn, cut or damaged cords and plugs replaced by an authorized service person.

**230 Volt Machine  
Instructions For Connection  
To The Power Supply  
And The Electrical Ground**

This machine must be connected to the electrical ground to protect the operator from electric shock. The machine has an approved power cord with two main conductors and one earthing conductor. Connect the plug to a receptacle as shown in Figure 2. The green (or green and yellow) conductor in the cord is the ground wire. Never connect this wire to any terminal other than the ground terminal.

Make sure you have the correct frequency and voltage before connecting the power cord to an outlet. The machine has a plug as shown in Figure 2. If a receptacle connected to the electrical ground as shown in Figure 2 is not available, have one installed by an electrical contractor. Do not use an adapter.

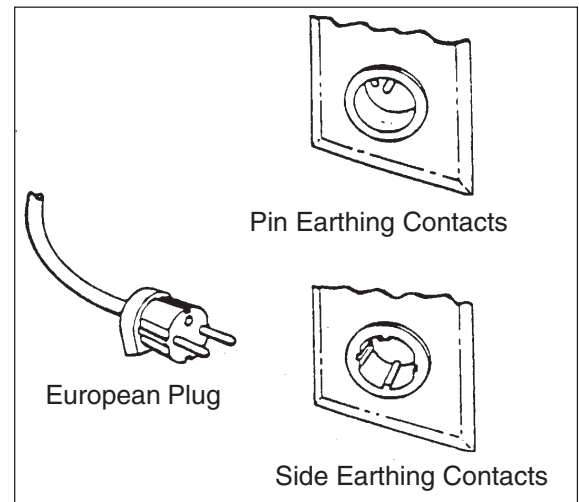

**Figure 2**

**⚠ WARNING:** This machine will operate only on AC frequency and electrical voltage shown on the nameplate. Make sure you have the correct frequency and voltage before connecting the power cord to an outlet. If you are not sure, consult your electrical contractor.

**⚠ WARNING:** Have worn, cut or damaged cords and plugs replaced by an authorized service person.

After using this machine, follow these instructions:

- Store the cord on the hook.
- Store the machine indoors away from sources of heat.

This machine is provided with an automatically reset thermal overload to avoid damage to the motor. If the thermal overload stops the motor unplug the machine and follow the procedures below:

- Empty the vacuum tank.
- Shake the filter bag to remove dust.
- In a few minutes the thermal overload will allow restarting of the motor.

**CLARKE TECHNOLOGY STV-20**  
**Single Motor Assembly Drawing & Parts List 1/98**

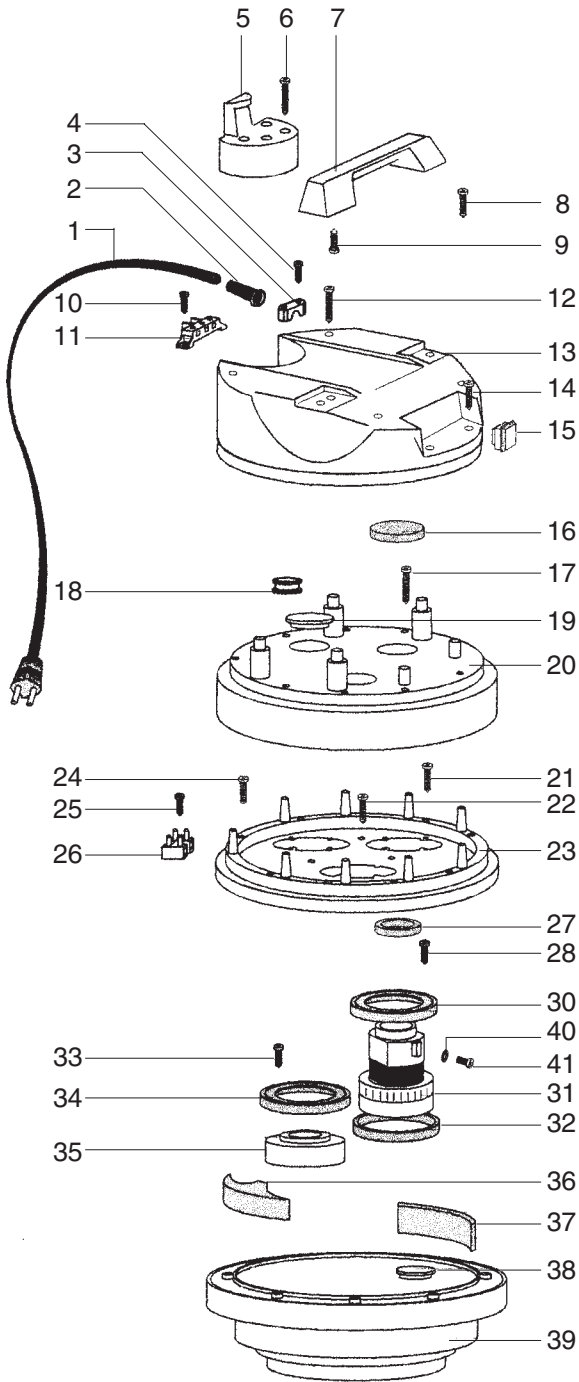

Ref.	Part No.	Description	Qty
1	51841A	Cord, Power	1
2	56448A	Strain Relief	1
3	54503A	Cord, Grip	1
4	56441A	Screw, 5mm x 20mm	2
5	51869A	Cord, Hook	1
6	88304A	Screw 5mm x 50mm	4
7	54922A	Handle, Lift	1
8	56482A	Screw 5mm x 35mm	2
9	56441A	Screw, 5mm x 20mm	4
10	88001A	Screw, 5mm x 14mm	2
11	40409A	Block, Terminal	1
12	88304A	Screw, 5mm x 50mm	2
13	52765A	Cover, Dome	1
14	56441A	Screw, 5mm x 20mm	2
15	47316B	Switch, Rocker	1
16	54064A	Filter, Upper	1
17	88304A	Screw, 5mm x 50mm	9
18	51872A	Clip, Spring	1
19	57162A	Plug, Upper	2
20	52799A	Cover, Motor	1
21	56483A	Screw, 5mm x 40mm	9
22	56483A	Screw, 5mm x 40mm	3
23	58410A	Support, Motor	1
24	58414A	Screw, 5mm x 30mm	1
25	56442A	Screw, 4.3mm x 19mm	1
26	50507A	Block, Terminal	1
27	57877A	Ring, Vac Motor	1
28	56441A	Screw, 5mm x 20mm	4
30	54377A	Gasket, Vac Motor	1
31	56039B	Motor, Vac 115V	1
	56046B	Motor, Vac 230V	1
	40834A	Brush, Carbon 115V	1
	40835A	Brush, Carbon 230V	1
32	54377A	Gasket, Vac Motor	1
33	56441A	Screw 5mm x 20mm	8
34	54377A	Gasket, Vac Motor	2
35	57163A	Plug, Motor	2
36	54058A	Foam, Triangle	3
37	54059A	Filter	3
38	57164A	Plug, Lower	2
39	50760A	Base, Motor	1
40	59859A	Washer, Star	1
41	56485A	Screw, 4mm x 8mm	1
NI	59887A	Wire, Connect	4
NI	52944A	Clip	2

NI= Not Illustrated

**CLARKE TECHNOLOGY STV-20D**  
**Dual Motor Head Assembly Drawing & Parts List 1/98**

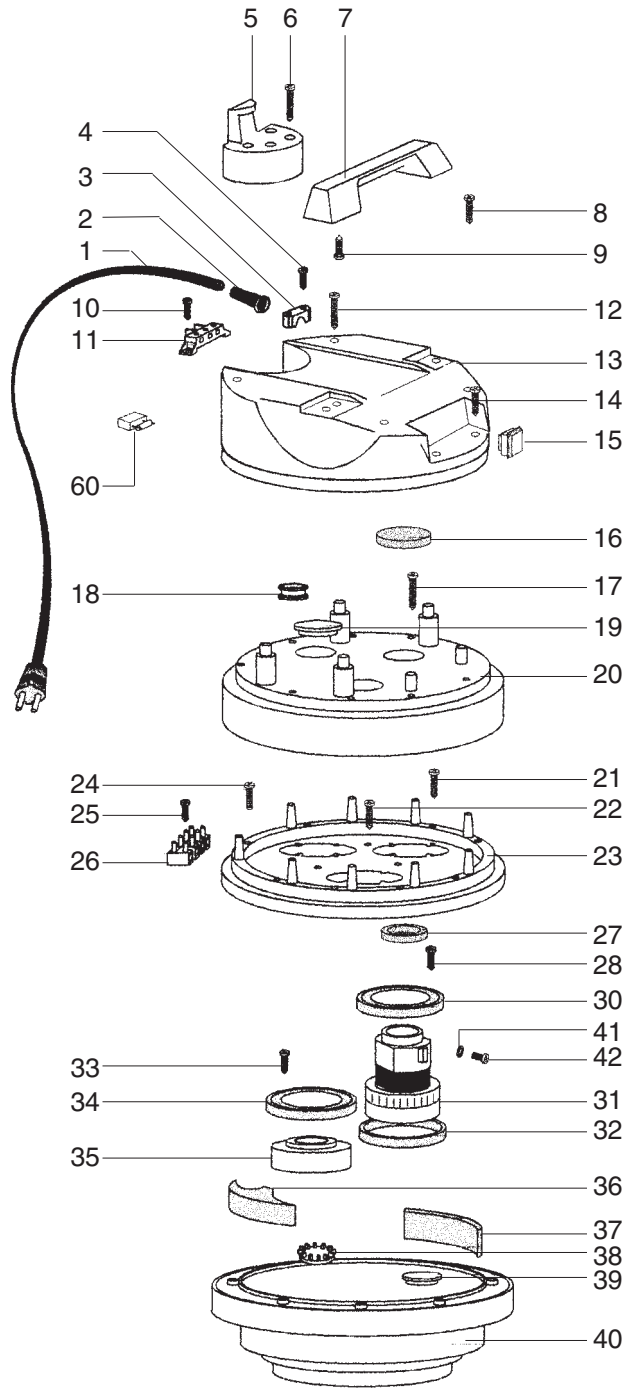

Ref.	Part No.	Description	Qty
1	51841A	Cord, Power	1
2	56448A	Strain Relief	1
3	54503A	Cord, Grip	1
4	56441A	Screw, 5mm x 20mm	2
5	51869A	Cord Hook	1
6	88304A	Screw, 5mm x 50mm	4
7	54922A	Handle, Lift	1
8	56482A	Screw 5mm x 35mm	2
9	56441A	Screw 5mm x 20mm	4
10	88001A	Screw 5mm x 14mm	9
11	59112A	Block, Terminal	1
12	88304A	Screw, 5mm x 50mm	2
13	52763A	Cover, Dome	1
14	56441A	Screw, 5mm x 20mm	2
15	47393A	Switch, Rocker	2
16	54064A	Filter, Upper	2
17	88304A	Screw, 5mm x 50mm	9
18	51872A	Clip, Spring	1
19	57162A	Plug, Upper	1
20	52799A	Cover, Motor	1
21	56483A	Screw, 5mm x 40mm	9
22	56483A	Screw, 5mm x 40mm	3
23	58410A	Support, Motor	1
24	58414A	Screw, 5mm x 30mm	1
25	56442A	Screw, 4.3 mm x 19mm	1
26	50761A	Block, Terminal	1
27	57877A	Ring, Vac Motor	2
28	56441A	Screw, 5mm x 20mm	8
30	54377A	Gasket, Vac Motor	2
31	44918B	Motor, Vac 115V	2
	44922B	Motro, Vac 230V	2
	40834A	Brush, Carbon 115V	1
	40835A	Brush, Carbon 230V	1
32	54377A	Gasket, Vac Motor	2
33	56441A	Screw, 5mm x 20mm	4
34	54377A	Gasket, Vac Motor	1
35	57163A	Plug, Motor	1
36	54058A	Foam, Triangle	3
37	54059A	Filter	3
38	59770A	Valve, Auto	2
39	57164A	Plug, Lower	1
40	50760A	Base, Motor	1
41	59859A	Washer, Star	2
42	56485A	Screw, 4mm x 8mm	2
NI	59887A	Wire, Connect	8
NI	52944A	Clip	3

NI= Not Illustrated

**CLARKE TECHNOLOGY STV-20**  
**Filter Bag & Float Assembly Drawing & Parts List 1/98**

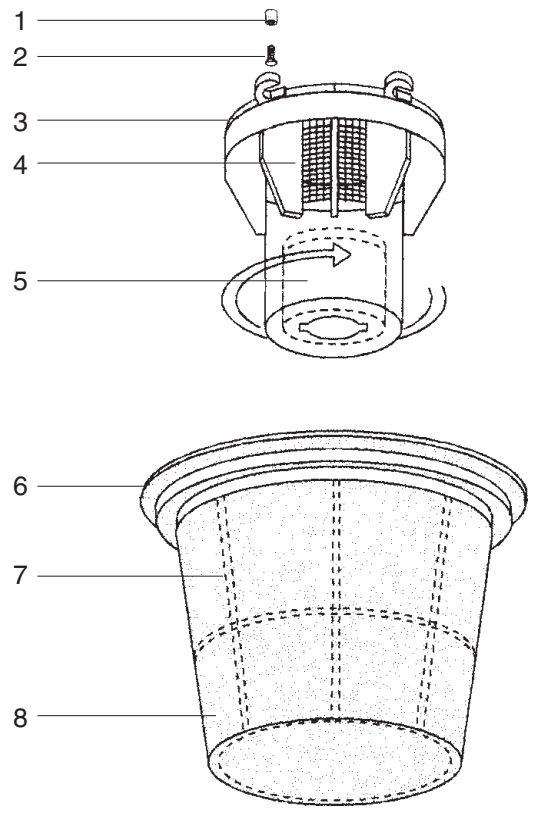

Ref	Part No.	Description	Qty
1	58541A	Spacer, Plastic	4
2	58413A	Screw, 5mm x 20mm	4
3	57856A	Cage, Float	1
4	54027A	Filter	1
5	53981A	Float	1
6	50339A	Adapter, Bag	1
7	50720A	Bag, Filter	1
8	56492A	Support, Filter Bag	1

To add optional filters for STV-20 or STV-20D order:  
 54015A Filter, HEPA 1 and 57372A Retainer 1  
 or  
 53982A Filter, Cartridge 1 and 57372A Retainer 1

**CLARKE TECHNOLOGY STV-20/STV-20D**  
**Tank Assembly & Tilt and Pour Carriage Drawing & Parts List 1/98**

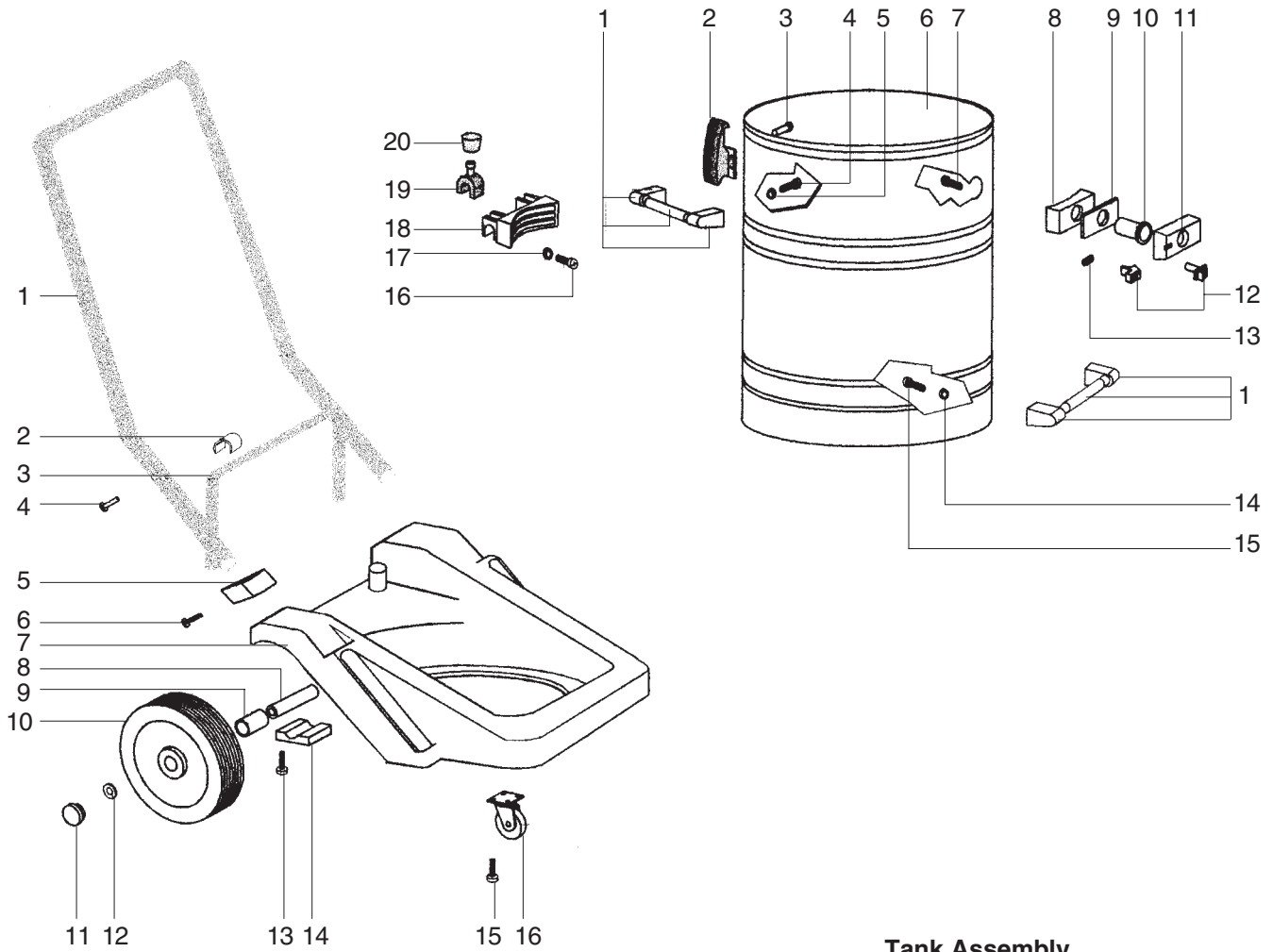

**Tilt and Pour Carriage**

Ref.	Part No.	Description	Qty
1	54921A	Handle, Transport	1
2	58529A	Spacer, Hinge	2
3	50460A	Pivot, Tank Support	1
4	57380A	Rivet	4
5	56490A	Support, Handle	1
6	56441A	Screw, 5mm x 20mm	4
7	51868A	Carriage, 20 gal.	1
8	50459A	Pivot, Wheel	2
9	51184A	Bearing, Spacer	2
10	59948A	Wheel, 20 gal.	2
11	54897A	Hub Cap	2
12	57853A	Ring, Snap	2
13	56441A	Screw, 5mm x 20mm	8
14	50555A	Block, Stirrup	2
15	56481A	Screw, 5mm x 30mm	8
16	52120A	Caster, Swivel	2

**Tank Assembly**

Ref.	Part No.	Description	Qty
1	54920A	Handle, Assembly	2
2	51823A	Clamp, Tank	2
3	57374A	Rivet	4
4	56481A	Screw, 5mm x 30mm	8
5	87055A	Washer	8
6	58925A	Tank, SS 20 gal.	1
7	56481A	Screw, 5mm x 30mm	4
8	57375A	Retainer, Poly Tank	1
9	54376A	Gasket, Tank Adaptor	1
10	53166A	Deflector, Tank	1
11	50336A	Adaptor, Hose	1
12	50524A	Button, Push	1
13	58692A	Spring, Push Button	1
14	87055A	Washer	4
15	56481A	Screw, 5mm x 30mm	4
16	56481A	Screw, 5mm x 30mm	4
17	87055A	Washer	4
18	50554A	Body, Hinge	1
19	55008A	Hinge, Locking	2
20	55534A	Knob, Hinge	2

**CLARKE TECHNOLOGY STV-20 & STV-20D**  
**Tool Kit Drawing & Parts List 1/07**

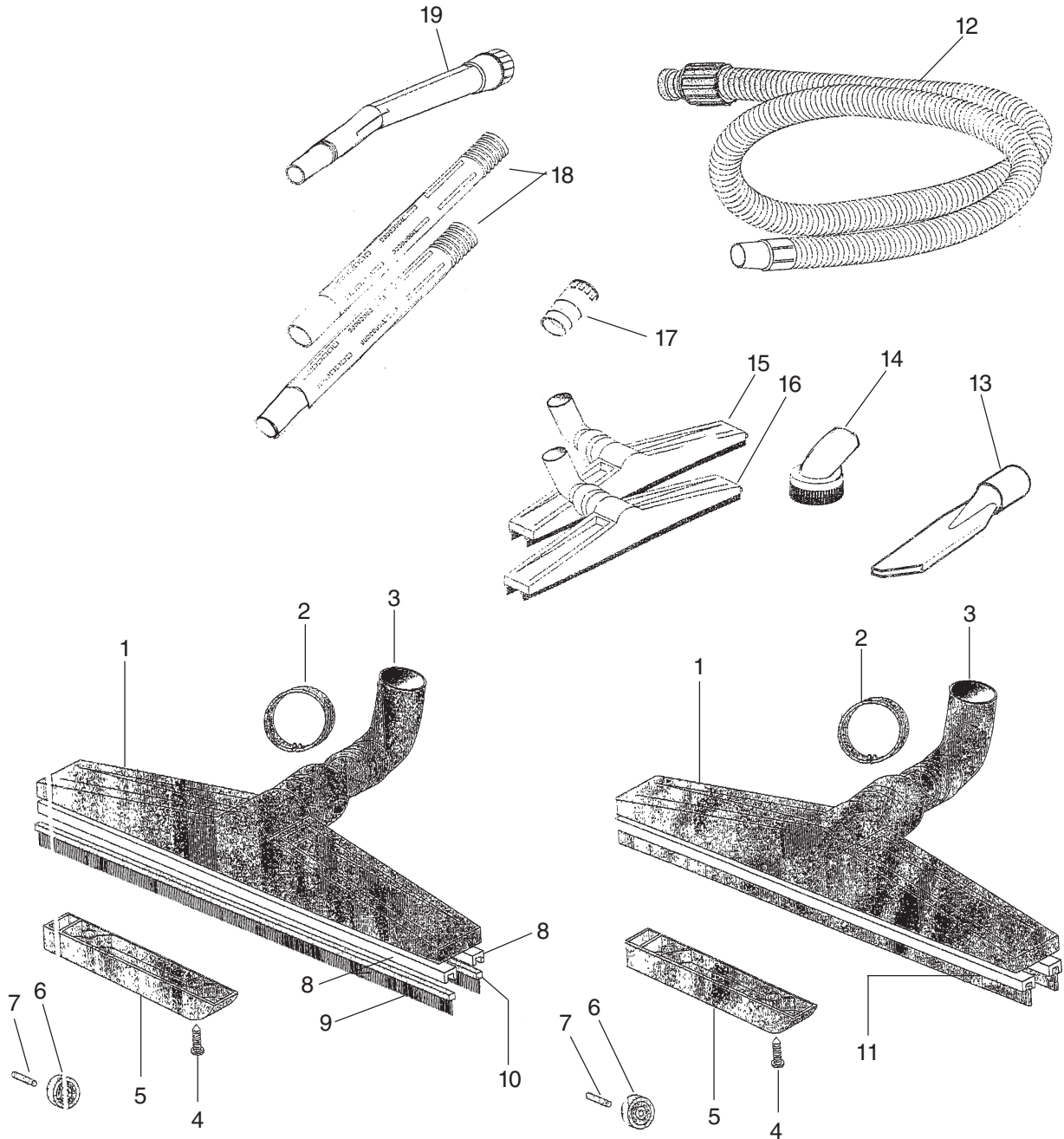

**Tool Kit - 55382B (includes items 12, 13, 14, 15, 16, 17, 18 & 19)**

Ref.	Part No.	Qty	Description
1	50753A	1	Body, Tool
2	57873A	1	Ring, Floor Tool
3◆	53796A	1	Adaptor, Floor Tool
4	53096A	2	Support, Floor Tool
5	88001A	4	Screw, 5mm x 15mm
6	59970A	2	Wheel
7	50819A	2	Axle
8	51716A	2	Brush Guide
9	51717A	1	Brush Strip Serrated

Ref.	Part No.	Qty	Description
10	51718A	1	Brush Strip Plain
11	53097A	2	Squeegee Blades
12	54887A	1	Hose, 38mm x 2.5 m
13	59215A	1	Tool Crevice
14	39205B	1	Tool, Dusting
15	59214C	1	Tool, Floor Brush
16◆	59213C	1	Tool, Squeegee
17	57503B	1	Reducer, Wand
18	59861B	2	Wand, Extension
19	59234A	1	Handle, Wand

NOTE: ◆ indicates a change has been made since the last publication of this manual.

# CLARKE PRODUCT SUPPORT BRANCHES

## U. S. A. Locations

### PRODUCTION FACILITIES

**Clarke®**, Springdale, Arkansas  
2100 Highway 265  
Springdale, Arkansas 72764  
(479) 750-1000  
**Customer Service - 1-800-253-0367**  
**Technical Service - 1-800-356-7274**

### SERVICE FACILITIES

**Clarke®**, Elk Grove, Illinois 60007  
2280 Elmhurst Road  
(847) 956-7900

**Clarke®**, Denver, Colorado 80204  
1955 West 13th Ave.  
(303) 623-4367

**Clarke®**, Houston, Texas 77040  
7215 North Gessner Road  
713-937-7717

### SERVICE AND SALES FACILITY

**American Lincoln® / Clarke**, Madison Heights,  
Michigan 48071-0158  
29815 John R.  
(810) 544-6300

**American Lincoln® / Clarke**, Marietta, Georgia 30066  
1455 Canton Road  
(770) 973-5225

---

**Clarke®**

**Clarke American Sanders**

**A.L. Cook**

**Customer Service Headquarters and Factory**  
2100 Highway 265  
Springdale, Arkansas 72764  
(479) 750-1000

**Technical Service**  
1-800-356-7274

## European Locations

### PRODUCTION FACILITIES

ALTO Danmark A/S, Aalborg  
Blytaekkervej 2  
DK-9000 Aalborg  
+45 72 18 21 00

ALTO Danmark A/S, Hadsund  
Industri kvarteret  
DK-9560 Hadsund  
+45 72 18 21 00

### SALES SUBSIDIARIES

ALTO US - Canada, Ontario (Canada)  
4080 B Sladeview Crescent Unit 1  
Mississauga, Ontario L5L 5Y5  
(905) 569 0266

ALTO Overseas Inc., Sydney (Australia)  
1B/8 Resolution Drive  
Caringbah NSW 2229  
+61 2 9524 6122

ALTO Cleaning Systems Asia Pte Ltd., Singapore  
No. 17 Link Road  
Singapore 619034  
+65 268 1006

ALTO Deutschland GmbH, Bellenberg (Germany)  
Guido-Oberdorfer-Straße 2-8  
89287 Bellenberg  
+49 0180 5 37 37 37

ALTO Cleaning Systems (UK) Ltd., Penrith  
Gilwilly Industrial Estate  
Penrith  
Cumbria CA11 9BN  
+44 1768 868 995

ALTO France S.A. Strasbourg  
B.P. 44, 4 Place d'Ostwald  
F-67036 Strasbourg  
Cedex 2  
+33 3 8828 8400

ALTO Nederland B.V.  
Postbus 65  
3370 AB Hardinxveld-Giessendam  
The Netherlands  
+31 184 677 200

ALTO Sverige AB, Molndal (Sweden)  
Aminogatan 18  
Box 4029  
S-431 04 Molndal  
+46 31 706 73 00

ALTO Norge A/S, Oslo (Norway)  
Bjornerudveien 24  
N-1266  
+47 2275 1770

## **CLARKE TECHNOLOGY WARRANTY**

This ALTO Industrial/Commercial Product is warranted to be free from defects in materials and workmanship under normal use and service for a period of one year from the date of purchase, when operated and maintained in accordance with Clarke's Maintenance and Operations Instructions.

This warranty is extended only to the original purchaser for use of the product. It does not cover normal wear parts such as electrical cable, rubber parts, hoses and motor brushes.

If difficulty develops with the product, you should:

- (a). Contact the nearest authorized Clarke repair location or contact the ALTO, CLARKE TECHNOLOGY Service Operations Department, 2100 Highway 265, Springdale, Arkansas 72764, for the nearest authorized Clarke repair location. Only these locations are authorized to make repairs to the product under this warranty.
- (b). Return the product to the nearest Clarke repair location. Transportation charges to and from the repair location must be prepaid by the purchaser.
- (c). Clarke will repair the product and/or replace any defective parts without charge within a reasonable time after receipt of the product.

Clarke's liability under this warranty is limited to repair of the product and/or replacement of parts and is given to purchaser in lieu of all other remedies, including INCIDENTAL AND CONSEQUENTIAL DAMAGES.

THERE ARE NO EXPRESS WARRANTIES OTHER THAN THOSE SPECIFIED HEREIN. THERE ARE NO WARRANTIES WHICH EXTEND BEYOND THE DESCRIPTION OF THE FACE HEREOF. NO WARRANTIES, INCLUDING BUT NOT LIMITED TO WARRANTY OF MERCHANTABILITY, SHALL BE IMPLIED. A warranty registration card is provided with your Clarke product. Return the card to assist Clarke in providing the performance you expect from your new floor machine.

ALTO, 2100 Highway 265, Springdale, Arkansas 72764.

**CLARKE TECHNOLOGY reserves the right to make changes or improvements to its machine without notice.**

**Always use genuine Clarke Parts for repair.**

The logo for ALTO features the word "ALTO" in a bold, sans-serif font. A large, stylized, curved line starts from the top left, arches over the letter 'A', and then curves down to the left, ending near the bottom of the 'A'. A registered trademark symbol (®) is positioned to the upper right of the 'O'.

**CLARKE TECHNOLOGY  
2100 Highway 265  
Springdale, Arkansas, 72764**