



Electronic Service Manuals

This electronic document is provided as a service to our customers. We do not create the contents of the information contained in this document. Should you have detailed questions pertaining to the information contained in this document, you may contact Michco, or the manufacturer which provided the original information in this electronic deliverable. Michco's only part in this electronic deliverable was the electronic assembly process. By providing this manual on line we are not guaranteeing parts availability.

You may contact Michco through the following methods:

Phone (517) 484-9312 or (800) 331-3339

2011 N. High St. -- Lansing, Michigan -- 48906

Fax: (517) 484-9836

Email: CustServe@Michco.com

Web site: www.Michco.Com

Parts Web site: www.FloorMachineParts.Com

Order Parts on Line at:

www.FloorMachineParts.Com

Directly to Parts & Service:

By Email: **Shop@Michco.com**

By Fax: (517) 702-2041

By Voice: Use numbers above.

Serving the Cleaning Industry Since 1922

Notice: All copyrighted material remains property of original owners, all trademarks are property of respective owners. Manuals are subject to Manufacturer's reproduction limitations. Originals or reproductions were provided by manufacturers through a request. We make no warranty as to the correctness of information provided in this document and you assume all risk. By placing these manuals on line we are not declaring our corporation to be an manufacturer authorized dealer or provider, please check our web site for authorized manufacturers we represent.

SA40



Service Manual

Clarke SA40 Models: 56104487 (20D)



Clarke®

English

03/2016, Form No. 56043173

Contents

General Information6
Machine Configurations6
Service Manual Purpose and Application6
Revision History6
Other Reference Manuals and Information Sources.6
Diagnostic and Service Tools.7
Conventions.7
Parts and Service7
Modifications7
Nameplate7
Cautions and Warning Symbols8
General Safety Instructions8
Prop Rod	10
Moving the Machine	10
Transporting the Machine	11
Specifications	11
<i>General Specifications.</i>	11
<i>Overall Dimensions</i>	12
Fastener Torque Specifications	12
Maintenance	13
<i>General Maintenance Information.</i>	13
<i>Maintenance Schedule</i>	13
Lubrication Locations	14
Major Machine Components	15
Machine Controls.	16
<i>Key Switch, Emergency Stop and Horn Switch</i>	16
<i>Circuit Breakers</i>	17
<i>Speed and Direction Controls and Indicators</i>	18
<i>Scrub Controls and Indicators</i>	19
<i>Solution Controls and Indicators</i>	20
<i>Vacuum Power Adjustment Switch and Indicators</i>	20
<i>Information Switch</i>	21
<i>Battery Status Screens</i>	22
Chassis System	23
Major Chassis Components	23
Platform Switches	24
Control System	25
Functional Description	25
Component Locations	26
Troubleshooting	26
<i>Fault Codes.</i>	26
<i>Fault Code Table.</i>	27
<i>System Disabled by Fault Codes</i>	28
<i>Service Test Mode</i>	29
<i>To Access the Service Test Mode.</i>	29
<i>Service Test Mode Functions.</i>	29

Programming Options	31
Main Menu Access	31
Submenu Functions	32
Deck Type	32
Low Battery Voltage Cutout	32
Battery Charger	33
Burst Of Power Operation	33
Detergent (EcoFlex™) Option	34
Chemical Rate Bias	34
Open Fault Detect.	34
Display Rev Level	34
Lock Out Brush Pressure	35
Lock Out Solution Flow Rate	35
Backup Alarm Volume	36
Forward Alarm Volume.	36
Horn Volume	36
Restore Defaults	37
Fault Recall	37
Service Test Mode.	37
Extra Information on the Graphic Display	38
Frozen Parameters	39
Panel Test	41
Save Scrub Settings	41
Removal and Installation.	42
A1 Control Board	42
E1 Curtis 1210 Speed Controller	43
A1 Control Board Shop Measurements.	45
Electrical System	47
Functional Description	47
Overview	47
On-board Battery Charger	48
Interlock Circuit	48
Delta-Q Charging Profiles and Charging Progress	50
Delta-Q Battery Charging Profile Table	50
Component Locations	52
Troubleshooting	54
Wiring Diagrams	55
Wiring (Ladder) Diagram	55
Wiring Harness Diagram	57
Electrical Connector Pin-out Assignments	58
To Locate and Identify a Connector	58
Connector Pin-out Assignment Tables	59
Recovery System	65
Functional Description	65
Circuit Descriptions.	66
Vacuum Motor Off.	66
Vacuum Motor On.	67
Component Locations	68
Troubleshooting	70
General Troubleshooting	70

<i>Bench-testing the Flyback Diode (bridge rectifier)</i>	71
Removal and Installation.	73
<i>Vacuum Motor.</i>	73
Specifications	74
Special Tools	74
Scrub System	75
Functional Description	75
<i>Scrub Deck and Motor</i>	76
<i>20D Scrub Deck</i>	76
<i>Brush Motor Contactor</i>	77
<i>Deck Actuator Assembly</i>	77
Circuit Descriptions.	79
<i>Scrub Brush Motor</i>	79
<i>Scrub Brush Motor Off</i>	79
<i>Scrub Brush Motor On</i>	80
<i>Deck Actuator Assembly</i>	81
<i>Scrub Deck Up.</i>	81
<i>Scrub Deck in Vacuum-only Position.</i>	81
<i>Scrub Deck at Normal Scrub Pressure.</i>	82
<i>Scrub Deck at Extra Scrub Pressure</i>	82
Component Locations	83
Troubleshooting	85
Removal and Installation.	86
<i>Scrub Deck</i>	86
<i>Scrub Deck Actuator Assembly</i>	90
Scrub Deck Actuator Adjustment	91
Specifications	92
Solution System.	93
Functional Description	93
<i>Solution Tank, Water Filter and Valves.</i>	93
<i>Solution Solenoid Valve</i>	94
Circuit Descriptions	95
<i>Solution Solenoid Valve Off</i>	95
<i>Solution Solenoid Valve On.</i>	96
Component Locations	97
Maintenance	99
<i>Cleaning the Water Filter</i>	99
Troubleshooting	99
Specifications	100
<i>Component Specifications</i>	100
<i>Nominal Solution Flow Rates</i>	100
Squeegee System	101
Functional Description	101
Component Locations	102
Troubleshooting	103
Specifications	103

Steering System	104
Functional Description	104
Component Locations	105
Troubleshooting	106
Wheel System - Traction	107
Functional Description	107
<i>Wheel Drive Motor Circuit Descriptions</i>	108
<i>Power to the E1 Curtis 1210 Speed Controller</i>	108
<i>Speed Control Drive Functions</i>	109
<i>Speed Control Communication with the A1 Control Board</i>	110
Component Locations	112
Maintenance and Adjustments	114
<i>Speed Control Programming Options</i>	114
Troubleshooting	115
<i>General Troubleshooting</i>	115
<i>E1 Curtis Speed Controller Diagnostics</i>	115
<i>Diagnostics Method A - Graphic Display and Direction Indicator</i>	115
<i>Diagnostics Method B - Curtis Programmer</i>	116
<i>Diagnostic History</i>	116
<i>Status LED Fault Code Table</i>	117
Removal and Installation	118
<i>Drive Wheel Assembly</i>	118
<i>Drive Wheel Motor</i>	120
<i>Steering Spindle Bearings</i>	122
Drive Wheel Motor Maintenance	124
<i>Replacing the Motor Brushes</i>	124
Specifications	125
<i>Shop Measurements</i>	125
<i>E1 Curtis 1210 Speed Controller – Low Current</i>	125
<i>E1 Curtis 1210 Speed Controller – Output</i>	126
<i>General Specifications</i>	126
Special Tools	127

General Information

Machine Configurations

The SA40 machine is a battery-powered commercial floor scrubbing machine suitable for use in hotels, schools, hospitals, factories, shops, offices, rental businesses and similar applications. The SA40-20D has a 20" brush deck to accommodate a variety of disc brushes, and can also be used with several grades of pads by using the optional pad holder.

The machine is powered by either four 6-volt batteries or two 12-volt batteries, connected in series, to provide 24 VDC to the motors and controls.

Service Manual Purpose and Application

This Service Manual is a technical resource designed to aid service personnel in maintaining and repairing the Advance SA40 Scrubbers to ensure optimum performance and long service life. Please read it thoroughly before servicing your machine.

Revision History

Date	Revisions
3/16	Initial publication

Other Reference Manuals and Information Sources

Model Name	Model Number	Parts List Form Number	Instructions for Use Form Number
Clarke SA40	56104487 (20D)	56042653	56091196 - English, Español, Français

These manuals can be found on the following Nilfisk-Advance's electronic supported databases:

- Nilfisk-Advance Dealer Customer Zone
- Advance website: www.advance-us.com
- Nilfisk website: www.nilfisk.com
- Clarke website: www.clarkeus.com
- EzParts service/parts CD-ROM

Diagnostic and Service Tools

In addition to a full set of metric and standard tools, the following items are required in order to successfully and quickly perform troubleshooting and repair of Advance commercial floor cleaning equipment.

- Digital voltmeter (DVM) with DC current clamp
- Hydrometer
- Battery load tester for checking batteries
- Set of torque wrenches

These tools are also available from Nilfisk-Advance, Inc.:

- Curtis 1311 hand held programmer, p/n 56409441,
- Vacuum water lift gauge, p/n 56205281.

Conventions

All references to right, left, front and rear in this manual are as seen from the Operator's position.

Parts and Service

Repairs should be performed by an Authorized Advance Service Center that employs factory-trained service personnel and maintains an inventory of Advance original replacement parts and accessories.

Call the Advance Dealer named below for repair parts or service. Please specify the Model Number (same as the Part Number) and Serial Number when discussing your machine.

Modifications

Modifications and additions to the cleaning machine which affect capacity and safe operation shall not be performed by the customer or user without prior written approval from Nilfisk-Advance Inc. Unapproved modifications will void the machine warranty and make the customer liable for any resulting accidents.

Nameplate

The Model Number (Part No.) and Serial Number of the machine are shown on the **Nameplate** located on the inside of the battery compartment.

This information is needed when ordering repair parts for the machine.



Cautions and Warning Symbols

Nilfisk-Advance uses the symbols below to signal potentially dangerous conditions. Read this information carefully and take the necessary steps to protect personnel and property.



Danger! *Is used to warn of immediate hazards that will cause severe personal injury or death.*



Warning! *Is used to call attention to a situation that could cause severe personal injury.*



Caution! *Is used to call attention to a situation that could cause minor personal injury or damage to the machine or other property.*



Read all instructions before using.

General Safety Instructions

Specific Cautions and Warnings are included to warn you of potential danger of machine damage or bodily harm. This machine is for commercial use, for example in hotels, schools, hospitals, factories, shops and offices other than normal residential housekeeping purposes.



Warning! *Be sure to follow these safety precautions to avoid situations that could cause severe personal injury.*

- This machine should only be used by properly-trained and authorized personnel.
- This machine is not intended for use by persons (including children) with reduced physical, sensory or mental capabilities, or lack of experience and knowledge.
- Avoid sudden stops when on ramps or inclines. Avoid abrupt sharp turns. Use low speed down ramps.
- Observe the Gross Vehicle Weight, GVW, of the machine when loading, driving, lifting or supporting the machine.
- Keep sparks, flame and smoking materials away from batteries. Explosive gases are vented during normal operation.
- Charging the batteries produces highly-explosive hydrogen gas. Charge the batteries only in well-ventilated areas away from open flame. Do not smoke while charging the batteries.
- Remove all jewelry when working near electrical components.
- Turn the Key Switch off (O) and disconnect the batteries before servicing electrical components.
- Never work underneath a machine without safety blocks or stands to support the machine.
- Do not dispense flammable cleaning agents, operate the machine on or near these agents, or operate in areas where flammable liquids exist.
- Only use the brushes provided with the machine or those specified in the Instructions for Use. The use of other brushes may impair safety.
- Do not clean this machine with a pressure washer.



Caution! *Be sure to follow these safety precautions to avoid situations that could cause personal injury, damage to property or equipment damage.*

- This machine is not approved for use on public paths or roads.
- This machine is not suitable for picking up hazardous dust.
- Do not use scarifier discs and grinding stones. Advance will not be held responsible for any damage to floor surfaces caused by scarifiers or grinding stones (can also cause damage to the brush drive system).
- When operating this machine, ensure that individuals in close proximity, particularly children, are not endangered.
- Before performing any service function, carefully read all instructions pertaining to that function.
- Do not leave the machine unattended without first turning the Key Switch off (O), removing the key and applying the parking brake.
- Turn the Key Switch off (O) and remove the key before changing the brushes, and before opening any access panels.
- Take precautions to prevent hair, jewelry or loose clothing from becoming caught in moving parts.
- Use caution when moving this machine in below-freezing temperature conditions. Any water in the solution, recovery or detergent tanks, or in the hose lines could freeze, causing damage to valves and fittings. Flush with windshield washer fluid.
- The batteries must be removed from the machine before the machine is scrapped. The disposal of the batteries should be safely done in accordance with your local environmental regulations.
- Do not use on surfaces having a gradient exceeding that marked on the machine.
- All doors and covers are to be positioned as indicated in the Instructions for Use before using the machine.
- This machine should only be used and stored indoors.



Caution! *Do not clean this machine with a pressure washer.*

Prop Rod

To prevent the **Control Panel Housing / Recovery Tank Cover** from dropping unexpectedly and causing injury, always engage the **Prop Rod** as shown before working under the **Panel Housing / Recovery Tank Cover**.

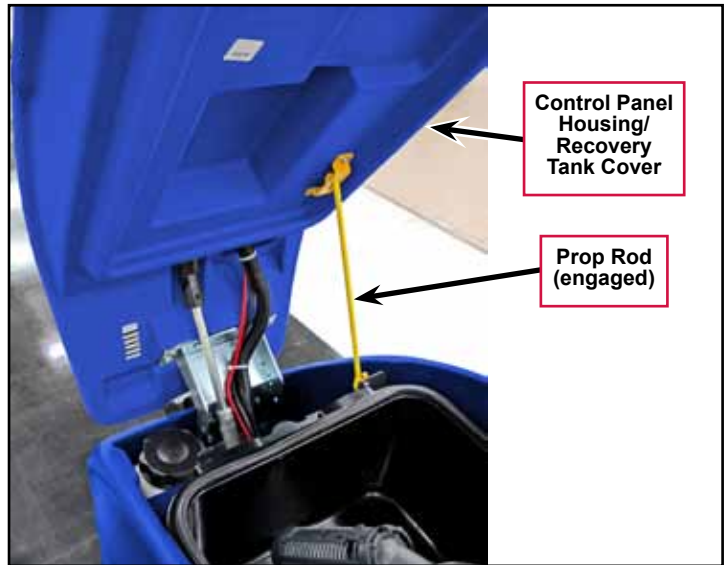

Moving the Machine

The drive wheel motor has a built-in electromagnetic brake that engages whenever the Key Switch is Off or the Go Pedal is released. You can manually override this brake if necessary by reaching up around the back of the front drive wheel and rotating the **Brake Arm** up as shown. This should only be done if you need to push or pull the machine. Remember to reengage the **Brake Arm** once you finish moving the machine.



*Note: Turn the drive wheel 45° to the right for easier access to the **Brake Arm**.*

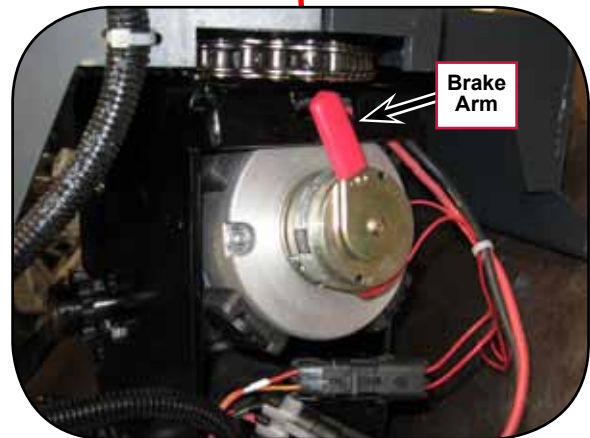
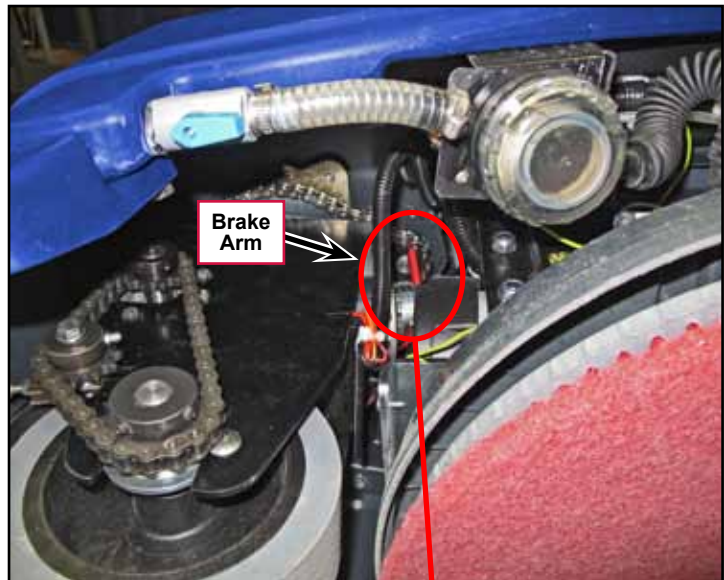

Transporting the Machine



Caution! Before transporting the machine on an open truck or trailer, make sure:

- All tanks are empty.
- The recovery tank cover is latched securely.
- The machine is tied down securely. (Refer to the Tie-down Locations below.)
- The machine's electromagnetic brake is engaged (not manually overridden).

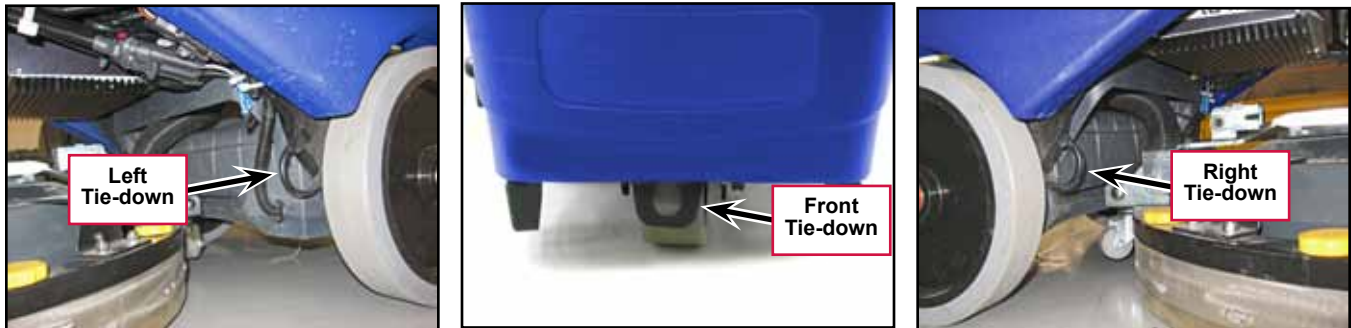

Specifications

General Specifications

Model	SA40-X20D
Model No.	56104487
Battery Voltage	24V
Battery Capacity	260 Ah
Protection Grade	IPX3
Sound Pressure Level IEC 60335-2-72: 2002 Amend. 1:2005, ISO 11201 dB(A)	63 dB LpA, ±3 dB KpA
Gross Vehicle Weight / Transport Weight	897 lbs / 407 kg
Empty Weight	620 lbs / 281 kg
Maximum Wheel-Floor Load, Front	160 psi / 1.10 N/mm
Maximum Wheel-Floor Load, Right-Rear	139 psi / 0.96 N/mm
Maximum Wheel-Floor Load, Left-Rear	135 psi / 0.93 N/mm
Scrub Deck Width	20 in / 50.8 cm
Squeegee Width	26.5 in / 67.3 cm
Tank Capacities	Solution Tank: 11.7 gal / 44.28 L
	Recovery Tank: 13.5 gal / 46.67 L
Sound Pressure Level IEC 60335-2-72: 2002 Amend. 1:2005, ISO 11201	63 dB LpA, ±3 dB KpA
Vibrations at the Hand Controls (ISO 5349-1)	0.17 m/s ²
Vibrations for the Whole Body (ISO 2631-1)	0.01 m/s ²
Gradeability	Transport: 14% / 7.1°
	Cleaning: 8.3% / 4.75°

Overall Dimensions

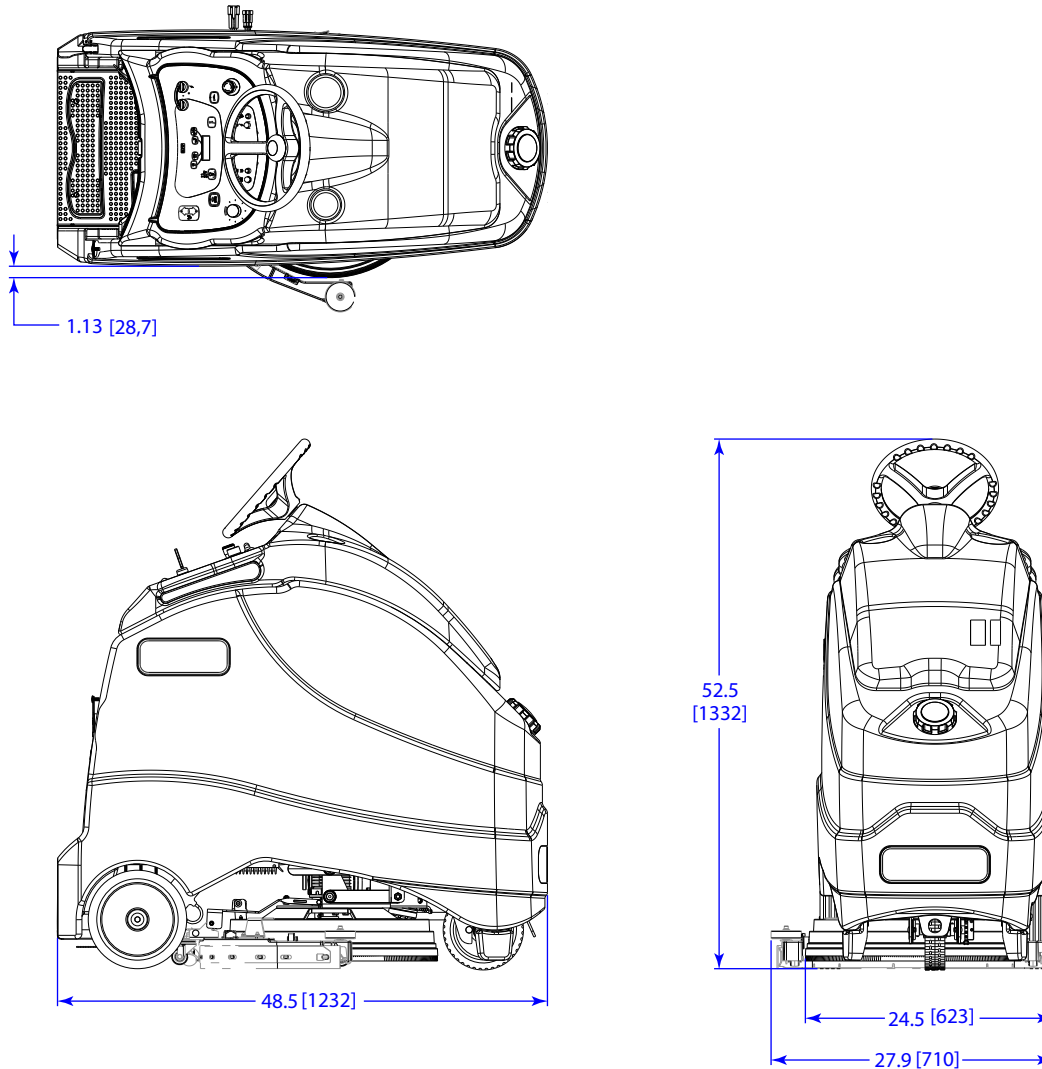

Fastener Torque Specifications

Standard Torque Specifications (unless otherwise specified)	Size	Plated Steel	Stainless Steel
	#10	42 in.-lb. [4.75 N-m]	28 in.-lb. [3.17 N-m]
1/4"	100 in.-lb. [11.3 N-m]	67 in.-lb. [7.57 N-m]	
5/16"	17 ft.-lb. [23.05 N-m]	11 ft.-lb. [14.91 N-m]	
3/8"	31 ft.-lb. [42.03 N-m]	20 ft.-lb. [27.12 N-m]	
1/2"	75 ft.-lb. [101.69 N-m]	50 ft.-lb. [67.79 N-m]	
3/4"	270 ft.-lb. [366.07 N-m]	180 ft.-lb. [244.05 N-m]	
M5	61 in.-lb. [6.89 N-m]	36 in.-lb. [4.07 N-m]	
M6	9 ft.-lb. [12.2 N-m]	62 in.-lb. [7.0 N-m]	
M8	22 ft.-lb. [29.83 N-m]	13 ft.-lb. [17.63 N-m]	
M10	44 ft.-lb. [59.66 N-m]	25 ft.-lb. [33.9 N-m]	
M12	70 ft.-lb. [94.91 N-m]	40 ft.-lb. [54.23 N-m]	

Maintenance

General Maintenance Information

Keep the machine in top condition by closely following the maintenance schedule. Maintenance intervals given are for average operating conditions. Machines used in severe environments may require service more often.



Caution! Do not pressure-wash the machine

Maintenance Schedule

Maintenance Item	Daily	Weekly	Monthly	Yearly
Charge Batteries	X			
Check/Clean Tanks & Hoses	X			
Check/Clean the Brushes/Pads	X			
Check/Clean the Squeegee	X			
Check/Clean Vacuum Shutoff Float	X			
Empty/Clean Debris Catch Tray in Recovery Tank	X			
Check Each Battery Cell(s) Water Level		X		
Inspect Scrub Housing Skirt		X		
Inspect and Clean Solution Filter		X		
Lubricate Machine			X	
* Check Carbon Brushes				X

* Have an Authorized Advance Service Center check the vacuum motor carbon motor brushes once a year or after 300 operating hours. The brush and drive motor carbon brushes should be checked every 500 hours or once a year.

Lubrication Locations

- Once a month apply Lubriplate® 730-2 or equivalent grease to, or grease the fitting on, the following components. Avoid using too much grease.
 - **Hex Shaft/Steering Tube Assembly**
 - **Drive Wheel Chain**
 - **Drive Chain Idler Sprocket** (grease fitting)
 - **Steering Chain**
- Once a month apply light machine oil to the **Upper and Lower Steering Shaft Universal Joints**.

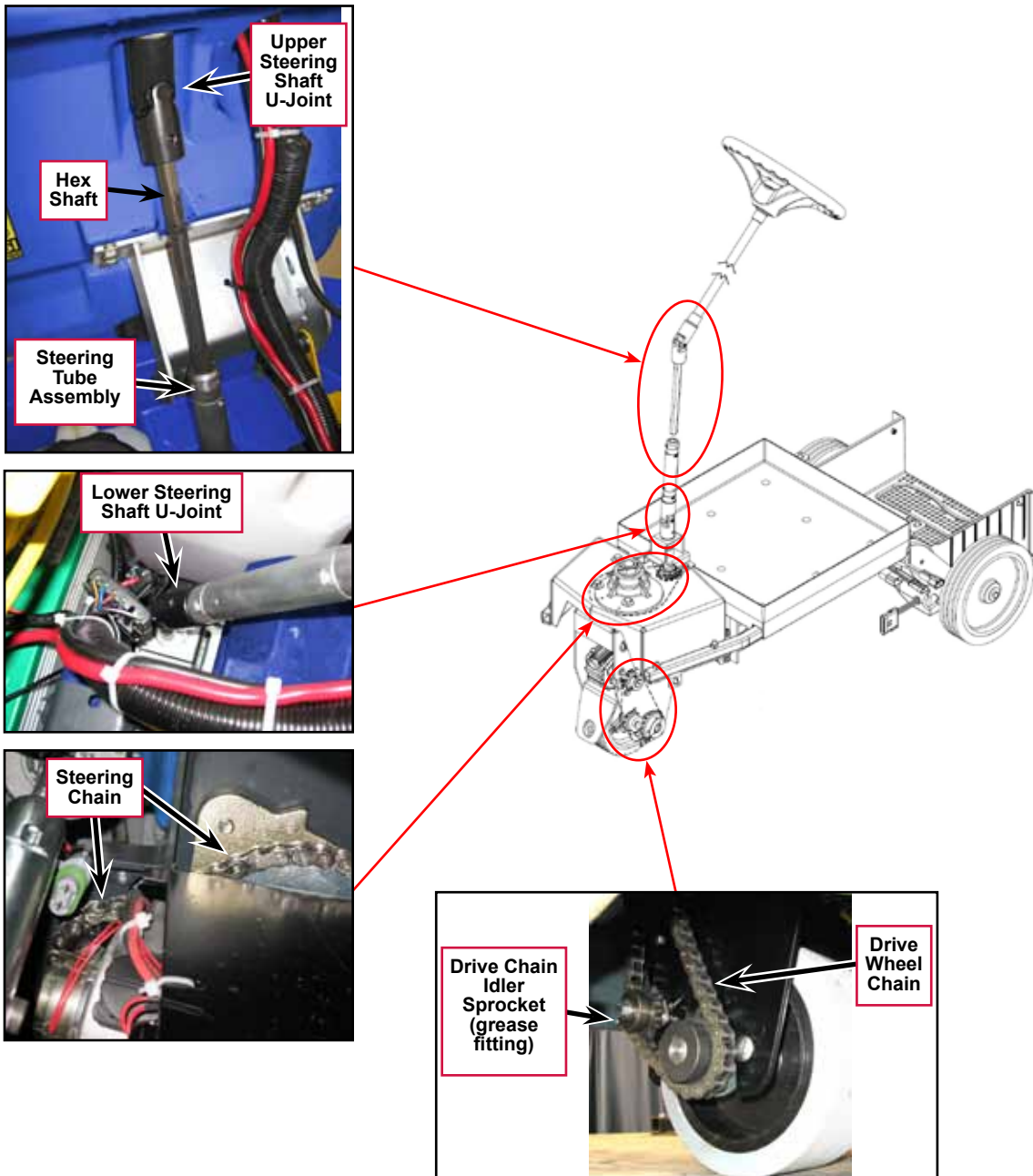

Major Machine Components

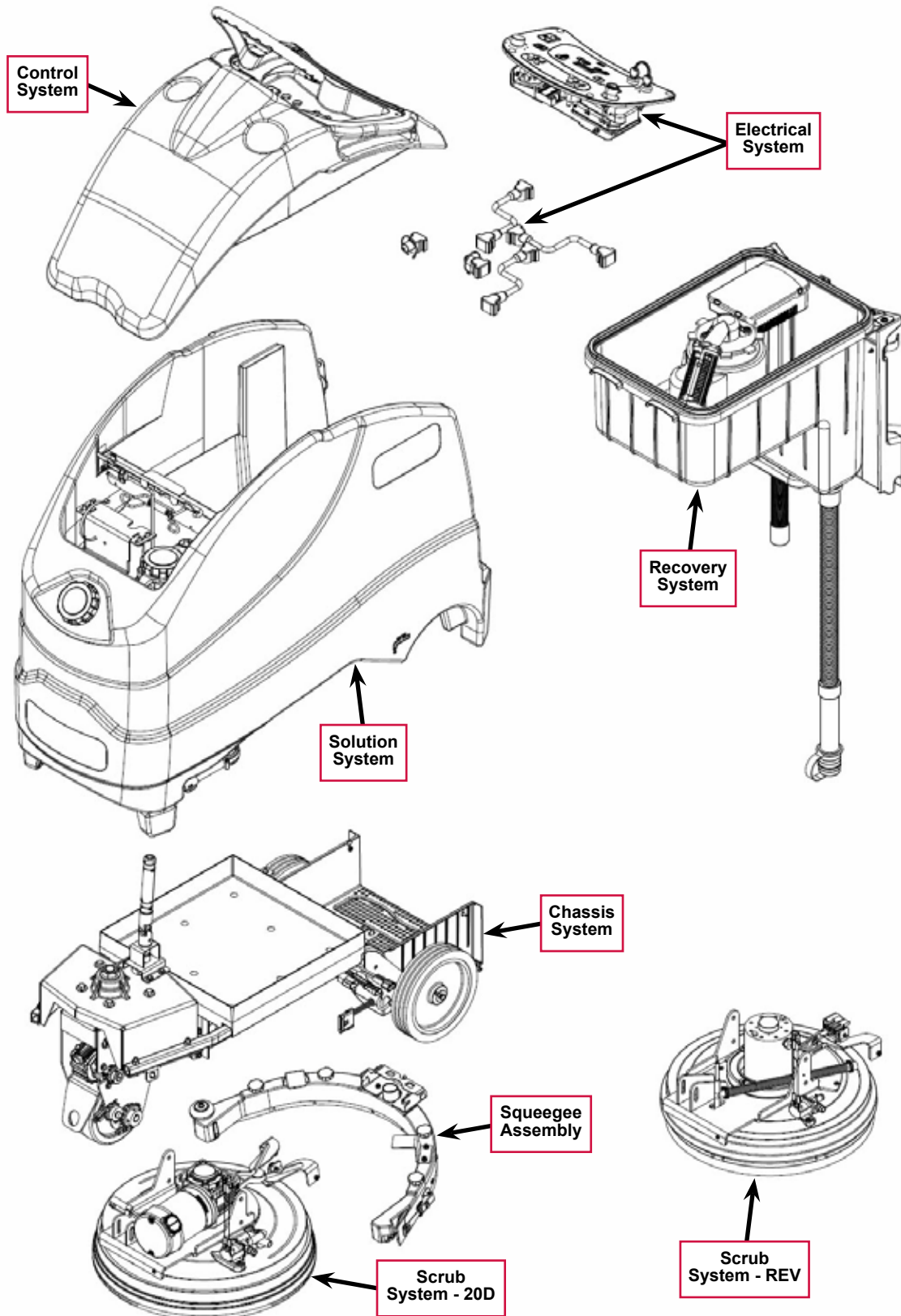

Machine Controls

Key Switch, Emergency Stop and Horn Switch

- **Key Switch** – controls the battery power to the machine. Note that you must turn the **Key Switch** to the on (I) position before stepping onto the machine platform.

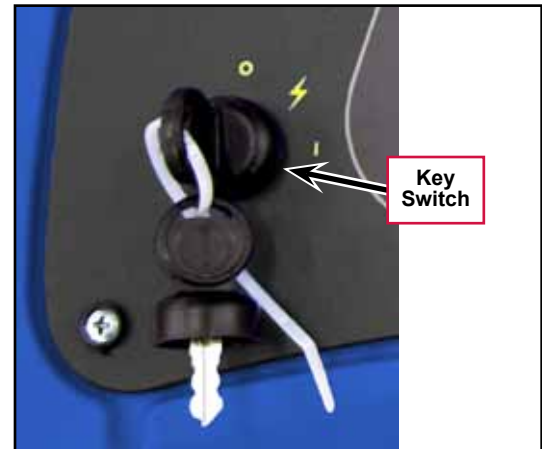

- **Emergency Stop** – shuts off all battery power to the machine when pressed. To reset the **Emergency Stop**, rotate the red knob clockwise.



- **Horn Switch** – sounds the horn when pressed.

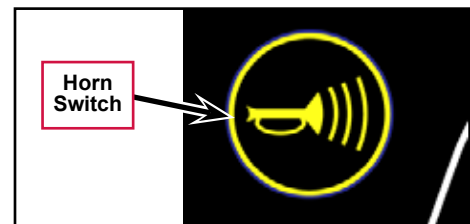

Circuit Breakers

The **Circuit Breakers** are mounted on the top of the control panel. To reset a **Circuit Breaker**, press the corresponding reset button

- **50-amp Circuit Breaker** – labeled **CB1** in the Ladder Diagram; controls the positive voltage to the E1 Curtis 1210 Speed Controller.
- **5-amp Circuit Breaker** – labeled **CB2** in the Ladder Diagram; controls the positive voltage to the key switch and to the battery positive inputs J3-1 and J3-8 on the A1 Control Board.

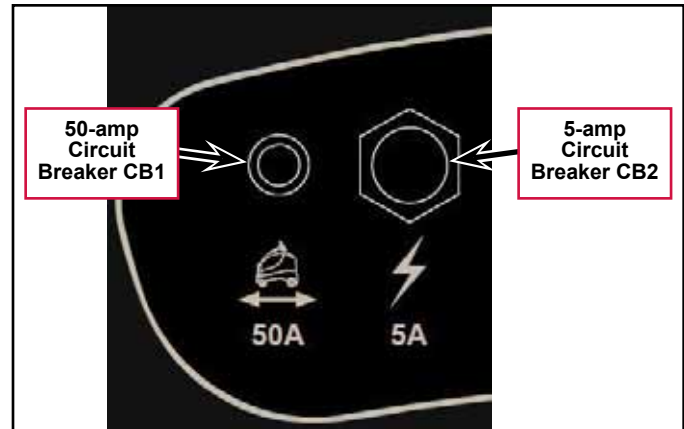

- **20-amp Circuit Breaker** – labeled **CB3** in the Ladder Diagram; controls the positive voltage to the contacts on solid state relay K1. Relay K1 controls the positive voltage to the vacuum motor, M4.
- **25-amp Circuit Breaker** – labeled **CB4** in the Ladder Diagram; controls the positive voltage to the contacts on relay K2. Relay K2 controls the positive voltage to the brush motor, M5/M6.

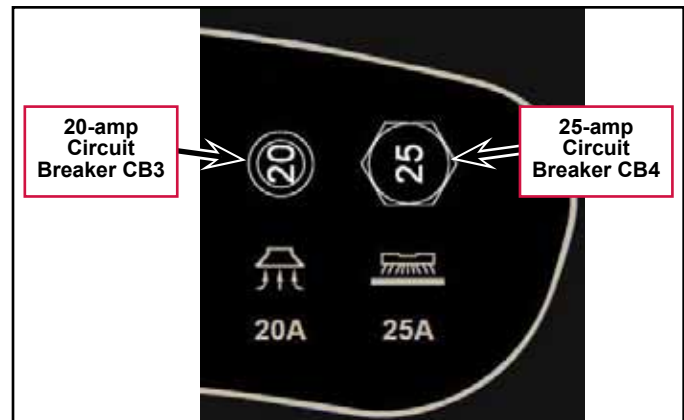

Speed and Direction Controls and Indicators

- The **Speed Adjustment Knob** – labeled R1 in the Ladder Diagram; 100K potentiometer that controls the machine speed in both forward and reverse.

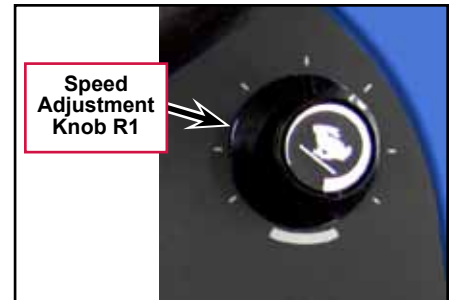

- The **Forward** and **Reverse Drive Switches** select the direction the machine will move when the Go Pedal is pressed. The corresponding **Drive Indicator** will light when a **Drive Switch** is selected.

- **Forward Drive Switch** – selects the forward direction.
- **Forward Drive Indicator** – lights to indicate that the **Forward Drive Switch** has been selected. Note that this indicator is lighted in the adjacent drawing.
- **Reverse Drive Switch** – selects the reverse direction.
- **Reverse Drive Indicator** – lights to indicate that the **Reverse Drive Switch** has been selected.

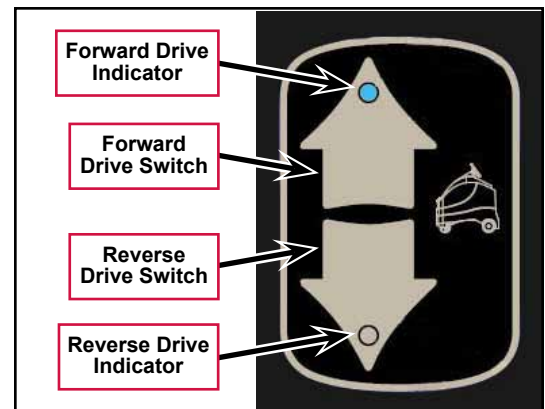

- **Operator Presence Pedal** – ensures that the Operator is standing on the **Platform** before the **Go Pedal** will drive the machine forward or reverse.
- **Go Pedal** – drives the machine in the direction selected with the Forward Drive or Reverse Drive Switches.

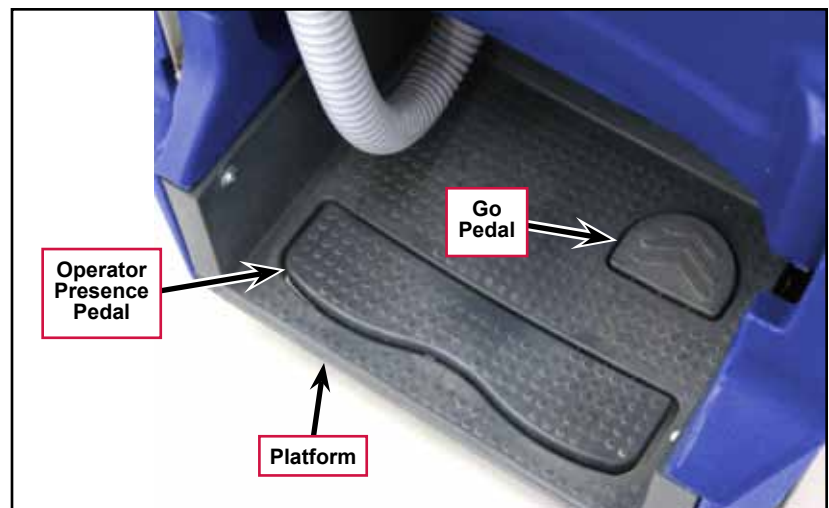

Scrub Controls and Indicators



The scrub pressure, recovery vacuum power, solution flow rate and detergent strength settings that will be in effect when the One-touch™ Scrub On/Off Switch is pressed is determined by the Save Scrub Settings submenu in the Programming Options.

- If **SAVE SCRUB SETTINGS/YES** is selected, the machine will use the scrub settings that were in use when the key switch was switched off.
- If **SAVE SCRUB SETTINGS/NO** is selected, the machine will use the default settings.

(Refer to the **Save Scrub Settings** subsection in the **Control System** section.)

- **One-touch™ Scrub On/Off Switch** – lowers the scrub deck and squeegee to the floor and enables the scrub, vacuum, solution and detergent systems. The scrub motor, solution system, detergent pump and vacuum motor will start when you press the Go Pedal.
- **Scrub On/Off Indicator** – lights to indicate that the scrub system is active.

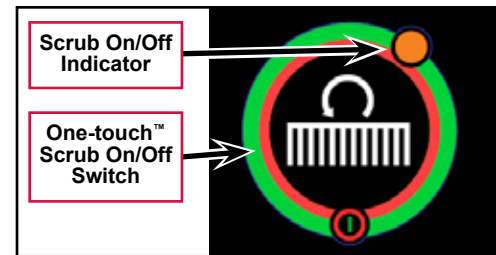

- **Extra Pressure Switch** – toggles the scrub pressure between standard pressure (bottom box filled as shown) and extra pressure (both top and bottom boxes filled).
- **Extra Pressure Indicator** – lights to indicate that the scrub system is active.
- **Scrub Brush Pressure Bar Graph** – displays the scrub pressure on the graphic display as follows:
 - Bottom box filled – standard scrub pressure (as shown).
 - Top and bottom boxes filled – extra scrub pressure.

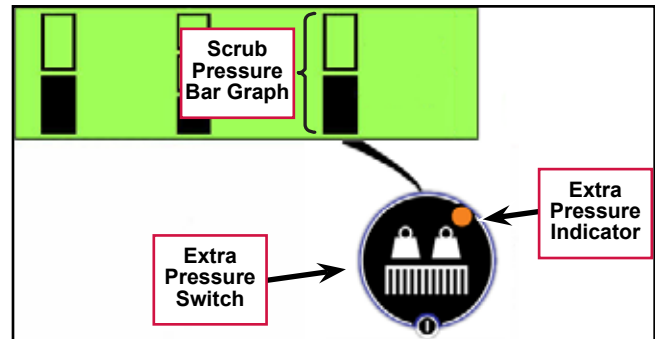

Solution Controls and Indicators

- **Solution Flow Adjustment Switch** – functions as follows:
 - When the scrub system is enabled, pressing the **Solution Flow Adjustment Switch** will cycle the solution flow rates from low (bottom box filled as shown), to medium (bottom two boxes filled), to high (all three boxes filled), then to off (no boxes filled).
 - When the scrub system is not enabled (machine in transport mode), pressing and holding the **Solution Flow Adjustment Switch** will dispense solution at the high flow rate to pre-wet the floor. The solution will continue to dispense as long as the **Solution Flow Adjustment Switch** is pressed.
- **Solution On/Off Indicator** – lights to indicate that the solution system is active.
- **Solution Flow Rate Bar Graph** – displays the solution flow rate on the graphic display as follows:
 - Bottom box filled – low solution flow rate (as shown).
 - Bottom two boxes filled – medium solution flow rate.
 - All three boxes filled – high solution flow rate.
 - All three boxes empty – solution system off.

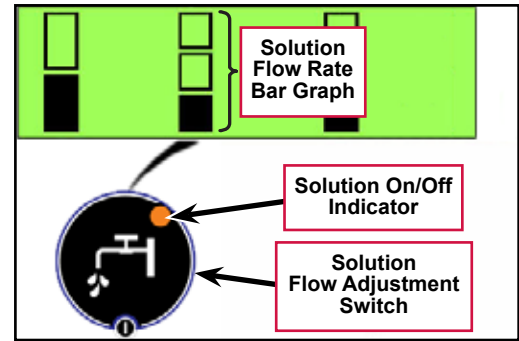

Vacuum Power Adjustment Switch and Indicators

- **Vacuum Power Adjustment Switch** – functions as follows:
 - Pressing the **Vacuum Power Adjustment Switch** while in the scrub mode will cycle the vacuum mode from low/quiet (bottom box filled as shown), to high/standard (both top and bottom boxes filled), then to off (no boxes filled). Note that the vacuum motor will switch on when the machine is driven forward. When the machine is driven in reverse or stops, or if the **Vacuum Power Adjustment Switch** is pressed while the vacuum motor is running, the vacuum motor will continue to run for 10 seconds, then switch off.

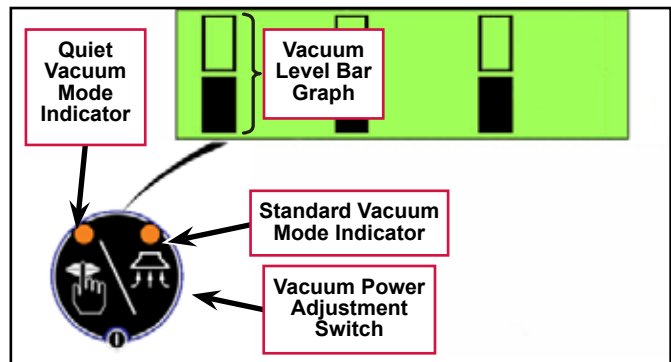

Pressing the **Vacuum Power Adjustment Switch** during this 10-second delay period will shut off the vacuum motor immediately.

- When the scrub system is not enabled (machine in transport mode), the **Vacuum Power Adjustment Switch** functions as follows:
 - Pressing the **Vacuum Power Adjustment Switch** once will enable the wet vacuuming mode. The vacuum power will default to the low/quiet mode and the deck actuator will drive the deck to the “vacuum only” position.
 - Pressing the **Vacuum Power Adjustment Switch** a second time will switch the vacuum motor to high/standard mode.
 - Pressing the **Vacuum Power Adjustment Switch** a third time will disable the wet vacuuming mode. The actuator will immediately raise the deck, and the vacuum motor will turn off after a 10-second delay.



If the One-touch™ Scrub On/Off Switch is pressed while wet vacuuming, the wet vacuuming mode will be disabled. The scrub deck and vacuum motor control will revert to the standard scrub mode operation.

- **Quiet Vacuum Mode Indicator** – indicates that the vacuum motor is in the low/quiet mode.
- **Standard Vacuum Mode Indicator** – indicates that the vacuum motor is in the high/standard mode.
- **Vacuum Level Bar Graph** – displays the vacuum motor power mode as follows:
 - Bottom box filled – low/quiet mode (as shown).
 - Top and bottom boxes filled – high/standard mode.
 - Both boxes empty – vacuum motor off.

Information Switch

- **Information Switch** – displays the Information Screen on the graphic display. The Information Screen will also be displayed if a significant error occurs that results in the shutdown of some machine system. The graphic display will then display the Information screen until next key switch cycle.

The Information Screen shows the **Hour Meter**, **Fault Codes** and the **Battery Charge Level Indicator**.

- **Hour Meter** – displays the total number of run hours on the machine.
- **Fault Codes** – displays the wrench icon  and any active two-digit fault code. If more than one error exists, the display will sequence through the error codes at one-second intervals. (Refer to the **Fault Codes** subsection in the **Control System** section.)
- **Battery Charge Level Indicator** – indicates the charge level of the batteries according to the number of filled “bars” in the battery icon.
 - Five solid bars indicates a full battery charge.
 - No solid bars (empty battery icon) indicates that the batteries are discharged.

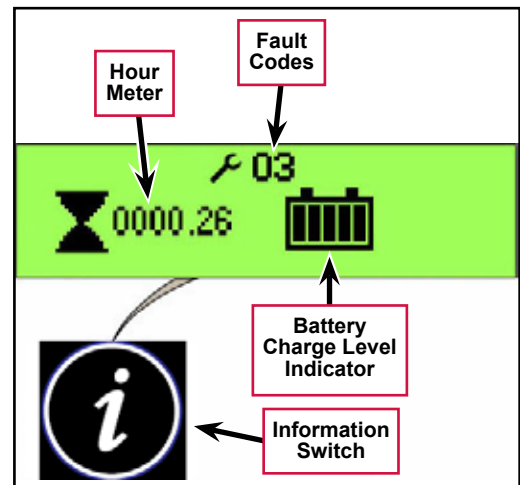

Battery Status Screens

- **Battery Low Voltage Screen** – displayed when the battery voltage drops to approximately 21.75 volts. The graphic display will alternate between the Battery Status Screen and the “normal” display at five-second intervals to alert the Operator that the batteries need charging and the remaining battery time is very short.

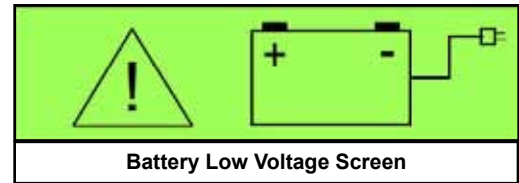

Note that:

- When the voltage in AGM or Gel batteries drops to 21.75 volts, the A1 Control Board switches off the scrub motor, solution system and detergent pump, and raises the scrub deck. The vacuum motor can still remain on.
- When the voltage in AGM or Gel batteries drops to 21.6 volts, the A1 Control Board switches off the vacuum motor.
- When the voltage in Wet batteries drops to 20.55 volts, the A1 Control Board switches off the scrub motor, solution system and detergent pump, and raises the scrub deck. The vacuum motor can still remain on.
- When the voltage in Wet batteries drops to 20.4 volts, the A1 Control Board switches off the vacuum motor.

Chassis System

Major Chassis Components

The Chassis System provides the framework on which the machine components are mounted.

The **Battery Tray** contains the batteries and connectors and is mounted to the top of the **Chassis Weldment**.

The **Platform Assembly** provides a place for the Operator to stand and houses the Operator Presence Pedal and Go Pedal.

The **Battery Charger** is mounted to the bottom of the **Chassis Weldment**.

The non-traction **Wheels** are held by flat washers and M8 x 20 screws that thread into the axle in the **Chassis Weldment**.

The **Drive Wheel Assembly** is fastened to the **Spindle Mount Weldment** which bolts to the **Chassis Weldment**.

The **Link Bar** and the two **Linkage Bars** are bolted to vertical plates on the bottom of the **Chassis Weldment** and support the Scrub Deck.

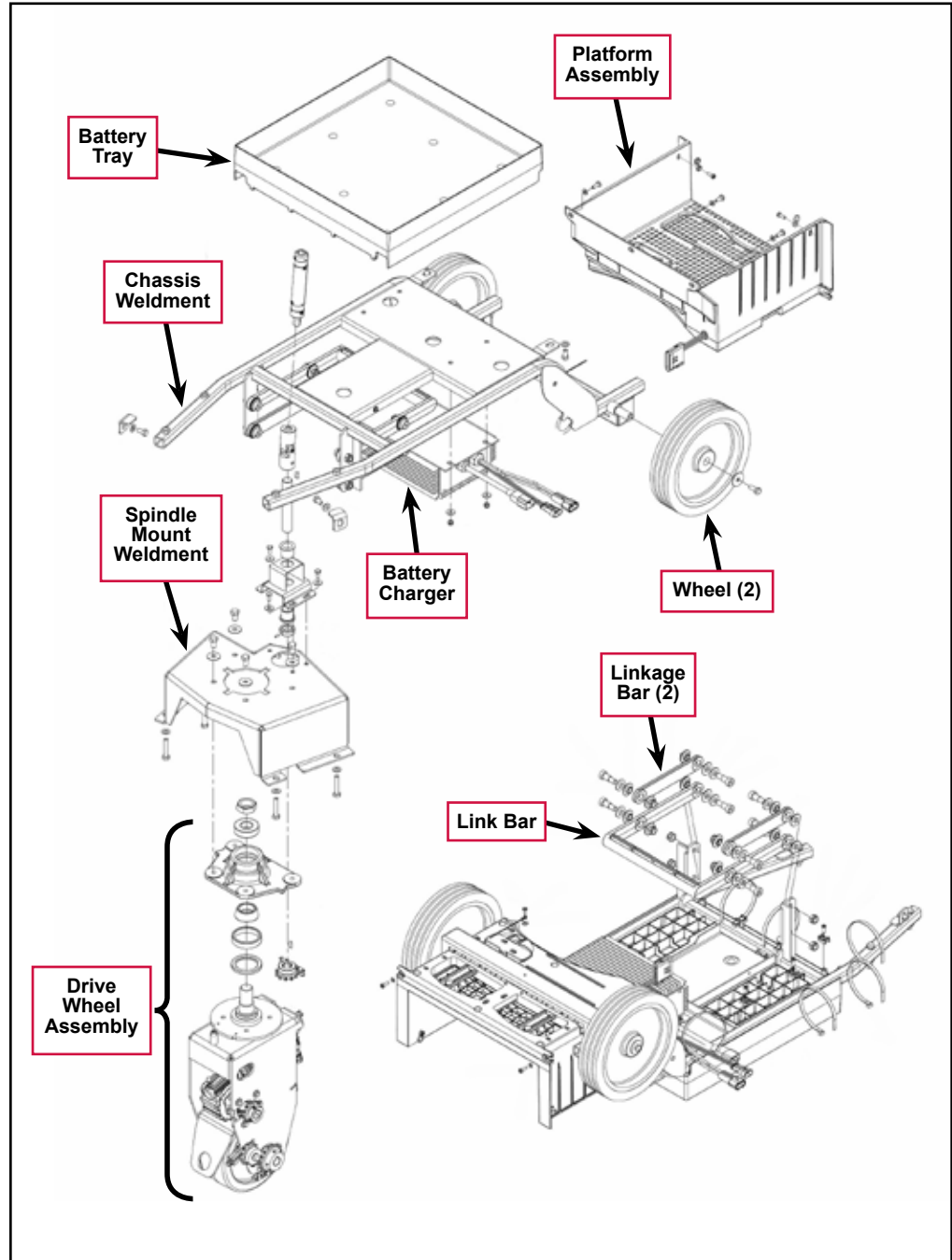

Platform Switches

The **Operator Presence Pedal** and **Go Pedal** are mounted on the top of the **Platform**.

- When the Operator stands on the **Platform**, he/she presses the **Operator Presence Pedal** which actuates the **Operator Presence Switch** (called the “Deadman Switch S2” in the **Wiring Diagram**). The **Operator Presence Switch** must be actuated before the **Go Pedal** will drive the machine forward or reverse.
- When the Operator presses the **Go Pedal** it actuates the **Go Switch** to drive the machine in the direction selected with the Forward Drive or Reverse Drive Switches.

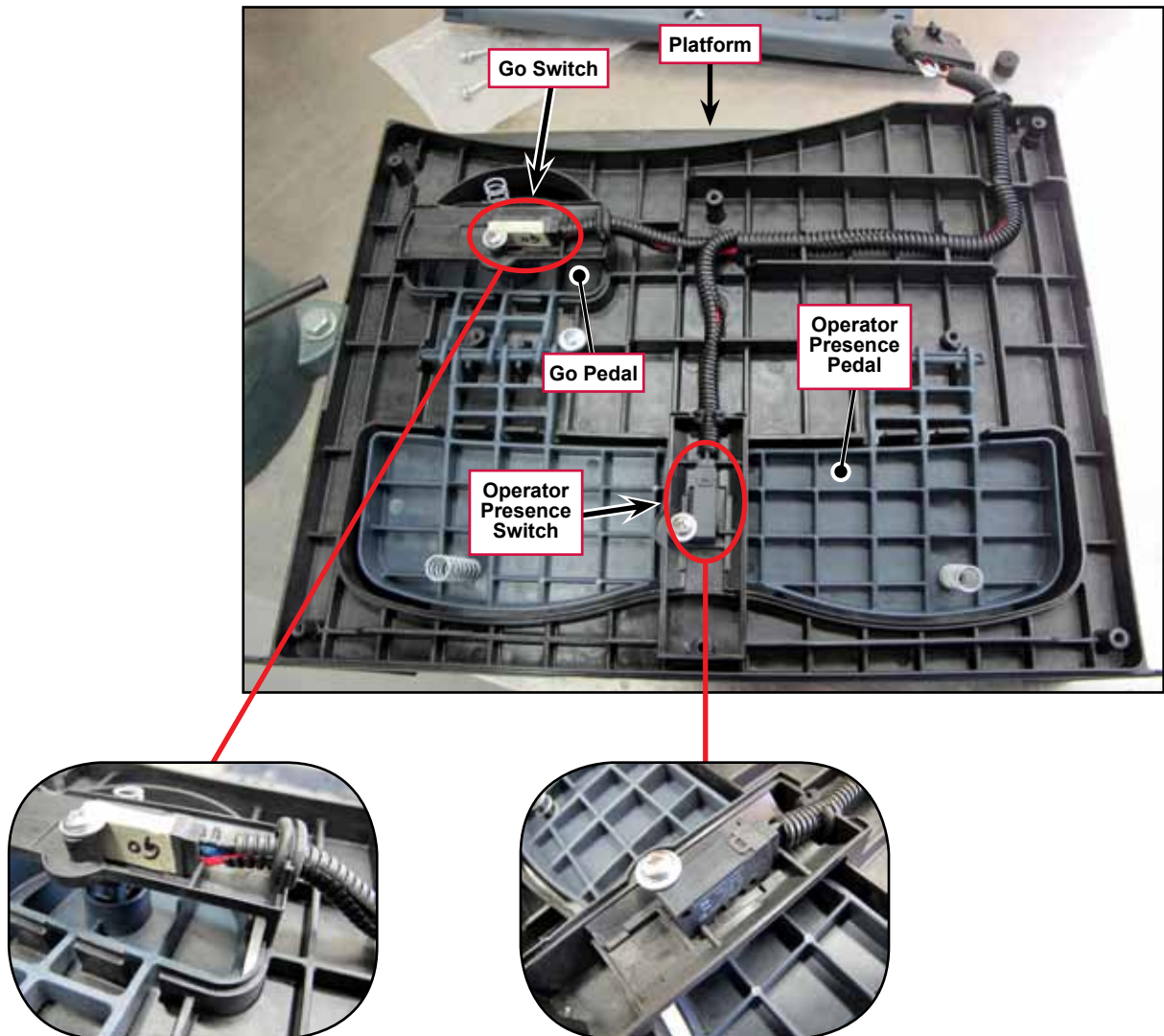

Control System

Functional Description

The Control System consists of the A1 Control Board (Main Machine Controller) and the E1 Curtis 1210 Speed Controller.

The A1 Control Board controls the scrubbing and wastewater recovery functions based on Operator requests, and motion and direction inputs from the E1 Curtis 1210 Speed Controller. The A1 Control Board can store and display a variety of fault codes to inform the Operator of any machine fault conditions. The A1 Control Board also supports special modes of operation called the “Programming Mode” and the “Service Test Mode”. The Programming Mode is used primarily for “telling” the A1 Control Board how the machine is equipped so that it can operate accordingly. The Service Test Mode allows you to operate various machine components regardless of current inputs.

The E1 Curtis 1210 Speed Controller controls the drive motor that propels the machine based on Operator requests. (Refer to the **Wheel System, Traction** section for more information.)

Component Locations

The following components are included in this section:

- A1 Control Board
- E1 Curtis 1210 Speed Controller

The **A1 Control Board** is mounted to the rear of the **Interface Panel Assembly**.

The **E1 Curtis 1210 Speed Controller** is mounted inside of the **Control Panel**.

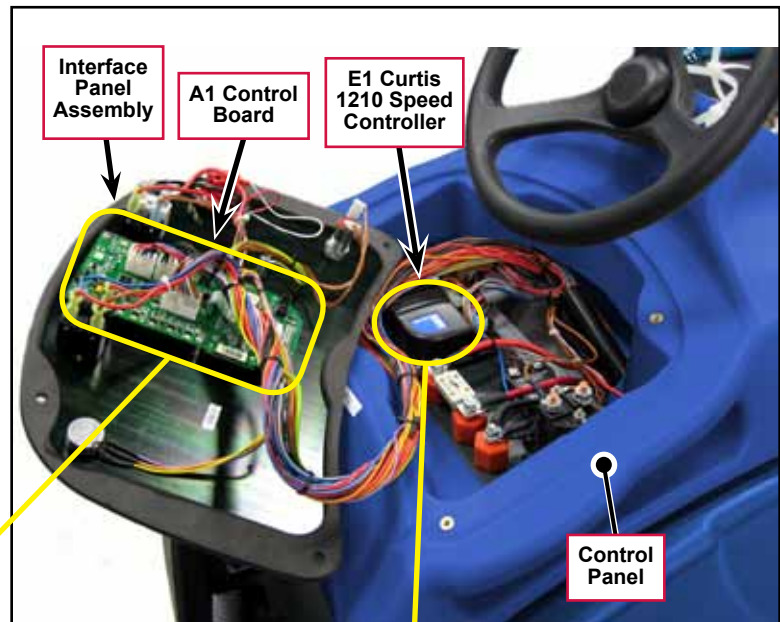

Troubleshooting

Fault Codes

The graphic display will show any error codes detected by the A1 Control Board on the Information Screen as they occur. The display will show the wrench icon  and the two-digit fault code number. The example shown here, **03**, is a speed control fault.



If more than one fault exists, the display will sequence through the fault codes at one-second intervals. If the error is significant and results in a machine system shutdown, the graphic display will show the Information Screen until next key switch cycle. Otherwise the Information Screen will be active only when the Information Switch is pressed.

Fault Code Table

Display Code	Fault Description	Conditions Needed to Set the Fault Code
03	Speed Control fault	The E1 Curtis Speed Controller is communicating a problem to the A1 Control Board.
04	Scrub Deck Actuator overload	The Scrub Deck Actuator has drawn more than 4.5 amps.
08	Solution Solenoid overload	The Solution Solenoid Valve has drawn more than approximately 1 amp.
09	Vacuum Contactor (SSR1) coil overload	The Vacuum Contactor has drawn more than approximately 1 amp.
10	Brush Contactor (K2) coil overload	The Brush Contactor has drawn more than approximately 1 amp.
11	Detergent Pump overload	The Detergent Pump has drawn more than approximately 1 amp.
21	Detergent Pump driver fault	The driver IC for the Detergent Pump is reporting a fault; current limiting or shutdown is in effect due to either a detected over-current or over-temperature condition.
24	Deck Actuator driver fault	The driver IC for the Deck Actuator is reporting a fault; current limiting or shutdown is in effect due to either a detected over-current or over-temperature condition
30	Solution Solenoid open	The measured current was below the minimum value while the Solution Solenoid should have been on.
32	Scrub Deck Actuator open	The measured current never exceeded the minimum threshold while moving from one deck position to another (only valid when the target position and the starting position switch states should be different).
35	Brush Contactor (K2) coil open	The measured current was below the minimum value while the Brush Contactor should have been on.
36	Vacuum Contactor (SSR1) coil open	The measured current was below the minimum value while the Vacuum Contactor should have been on.
37	Detergent Pump open	The measured current was below the minimum value while the Detergent Pump should have been on.
52	Scrub Deck Actuator position fault	The measured current was greater than or equal to the minimum threshold value while the deck was moving, but the software timed out looking for the new position (never saw the actuator switch states read the target values).
62	Solution Solenoid driver on	The measured current was above the minimum value while the Solution Solenoid driver should have been off.
63	Brush Contactor (K2) driver stuck on	The measured current was above the minimum value while the Brush Contactor driver should have been off.
64	Vacuum Contactor (SSR1) driver stuck on	The measured current was above the minimum value while the Vacuum Contactor driver should have been off.
65	Detergent Pump driver stuck on	The measured current was above the minimum value while the Detergent Pump driver should have been off.
70	On-board Battery charger fault	An error has been generated via the serial communications between the charger and the A1 Control Board due to an incorrect charging profile code being repeatedly sent by the charger, or the bit timing being severely out of spec.

Service Test Mode

The Service Test Mode allows you to switch the individual electrical system components on and off independent of the normal Operator inputs. This serves as a “shortcut” when troubleshooting the machine systems. Service Test Mode is accessed through the hidden menu system which is described in [“Programming Options”](#) on page 31.



Note: Service Test Mode is not available if the machine is being charged.



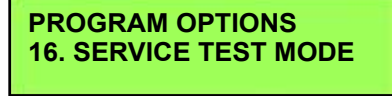
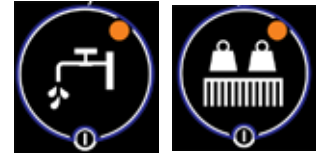

To Access the Service Test Mode











1. With the machine off, press and hold the solution switch and brush pressure switch while turning the machine on, and continue to hold the switches.
2. Continue to hold the switches until the display shows “Programming Options”.
3. Press the Forward or Reverse switches to scroll through the menu options until “16. Service Test Mode” is visible.
4. Press the scrub on/off switch to enter service test mode. The display will show the Service Test Mode submenu.
5. Refer to “Service Test Mode Functions” below for a description of the available functions.
6. To exit service test mode, turn off the key switch.

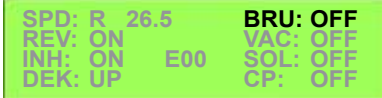

Service Test Mode Functions

The control panel switches are used to control various A1 Control Board output functions. The table below lists the control panel switches, and their corresponding Service Test Mode functions and displays:

Control Panel Switch	Service Test Mode Function	Graphic Display Descriptions
Forward Drive Switch 	The Forward Drive Switch enables the machine to drive forward. The blue LED indicator will be lit when the Switch is active. For the machine to move forward, the Emergency Stop must be reset, the Operator Presence Pedal must be pressed and the Go Pedal must be pressed. Note that the Inhibit (INH) output must be off (via the Information Switch – see below).	 <ul style="list-style-type: none"> • SPD: – indicates the drive controller state. In this case it would display F for forward. • The three digits display the battery voltage (26.5 volts in this example).
Reverse Drive Switch 	The Reverse Drive Switch enables the machine to drive in reverse. The blue LED indicator will be lit when the Switch is active. For the machine to move backward, the Emergency Stop must be reset, the Operator Presence Pedal must be pressed and the Go Pedal must be pressed. Note that the Inhibit (INH) output must be off (via the Information Switch – see below).	 <ul style="list-style-type: none"> • SPD: – indicates the drive controller state. In this case it would display R for reverse. • The three digits display the battery voltage (26.5 volts in this example). • REV: – indicates that the reverse output is ON.

Control Panel Switch	Service Test Mode Function	Graphic Display Descriptions
<p>Information Switch</p> 	<p>Pressing the Information Switch toggles the Inhibit output (INH) from the A1 Control Board to the E1 Curtis Speed Controller ON and OFF. Note that INH must be OFF in order to test the forward and reverse drive in the Service Test Mode.</p>	 <ul style="list-style-type: none"> • INH – indicates the state of the inhibit signal. In this case the inhibit signal is ON. • E(NN) – displays any active fault codes.
<p>Extra Pressure and Horn Switches</p>  	<p>Pressing the Extra Pressure Switch scrolls the DEK: field through the four available deck positions:</p> <ul style="list-style-type: none"> • UP – raised (transport) position • VAC – vacuum-only (wet vacuuming) position • LOW – standard scrub pressure position • HI – extra scrub pressure position <p>Pressing the Horn Switch will move the deck to the selected position. Note that the Extra Pressure Switch is locked out while the deck is moving. The DEK: line will be highlighted and inverted.</p>	 <p>DEK: – indicates the scrub deck position. In this case the deck would be in the UP (transport) position.</p>
<p>Scrub On/Off Switch</p> 	<p>Pressing the Scrub On/Off Switch toggles the brush motor contactor and scrub deck motor ON and OFF.</p>	 <p>BRU: – indicates the state of the brush motor. In this case the motor would be OFF.</p>
<p>Vacuum Power Adjustment Switch</p> 	<p>Pressing the Vacuum Power Adjustment Switch scrolls the Solid State Relay (K1) and Vacuum Motor among the three states: OFF (0V), LOW (16.8V) and HI (battery voltage).</p>	 <p>VAC: – indicates the state of the vacuum motor. In this case the motor would be OFF.</p>
<p>Solution Flow Adjustment Switch</p> 	<p>Pressing the Solution Flow Adjustment Switch toggles the solution solenoid ON and OFF. When the solenoid is ON it will operate at 50% duty cycle (1 cycle = 3 seconds ON, 3 seconds OFF).</p>	 <p>SOL: – indicates the state of the solution solenoid. In this case the solenoid would be OFF.</p>

Programming Options

The SA40 graphic display has two “layers” of hidden menus that allow you to view and change the various programmable machine configurations, system settings and parameters. The top “layer” is the main menu from which you can navigate to the 20 submenus. The second “layer” is the submenus that display the programmable options. These submenus are the screens on which you can change the configurations and settings.



Note: The hidden menu is not available if the machine is being charged.

Main Menu Access

1. With the machine off, press and hold the solution switch and brush pressure switch while turning the machine on, and continue to hold the switches.
2. Continue to hold the switches until the display shows “Programming Options”.
3. Press the Forward or Reverse switches to scroll through the menu options.
4. Press the scrub on/off switch to either enter or exit (with save) a submenu.
5. Within a submenu, press the forward/reverse switches to scroll through the options.
6. The main menu contains the following links to the corresponding programming option submenus:

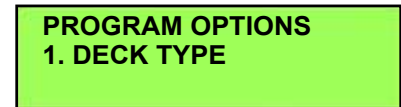
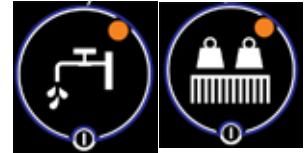

1. DECK TYPE
2. LOW VOLTAGE CUTOUT
3. BATTERY CHARGER
4. BURST OF POWER
5. DETERGENT OPTION
6. DETERGENT RATE BIAS
7. OPEN FAULT DETECT
8. DISPLAY REV LEVEL
9. LOCKOUT BRUSH
10. LOCKOUT SOLUTION
11. BACKUP ALARM VOL
12. FWD ALARM VOL
13. HORN VOL
14. RESTORE DEFAULTS
15. FAULT RECALL
16. SERVICE TEST MODE
17. XTRA INFO ON DISPLAY
18. FROZEN PARAMETERS
19. PANEL TEST
20. SAVE SCRUB SETTINGS



Service Note:

Not all menu entries listed will be functional, depending on the machine configuration.



Service Note:

*The A1 Control Board will automatically display the main menu upon machine power-up if no scrub deck has been selected and saved in the **DECK TYPE** submenu. This will occur when a new Control Board is installed into a machine, or the **RESTORE DEFAULTS** has been performed. The purpose of this is to prompt the Operator to select the appropriate deck type before using the Control Board in the machine. Once the deck type has been selected, the controller will no longer automatically display the main menu at machine power-up.*

Submenu Functions

Deck Type

The SA40 supports only 1 deck type. So this function should not be changed. This submenus allow you to specify the type of deck installed in your machine. Note that the type of deck selected configures the solution flow rate settings corresponding to the deck type.

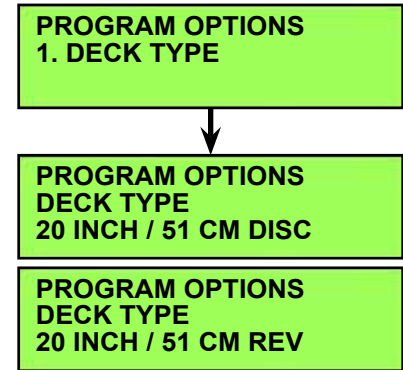

Low Battery Voltage Cutout

The purpose of the low battery voltage cutout is to help prolong battery life. The A1 Control Board will raise the deck, and switch off the brush and vacuum motors, and solution solenoid valve automatically when the batteries discharge to the selected cutout level. The **2. LOW VOLT CUTOUT** submenus allow you to select the voltage cutout level for the type of battery installed in your machine:

- The standard cutout setting for wet cell/lead acid batteries is 20.55 volts (80% discharged or 20% charge remaining).
- The alternate cutout setting for gel/maintenance free batteries is 21.75 volts (70% discharged or 30% charge remaining).

The default setting is **WET BATTERY 80% / LVC=20.55V**.

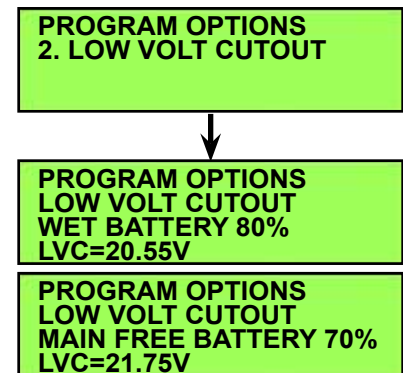

Battery Charger

The current series of battery chargers don't communicate with the A1 control board. So this menu entry has no current function. If there was communication, this menu entry would permit the A1 control board to notify the charger which type of battery was being charged so the on-board charger would use the charging algorithm that is compatible with the battery type.

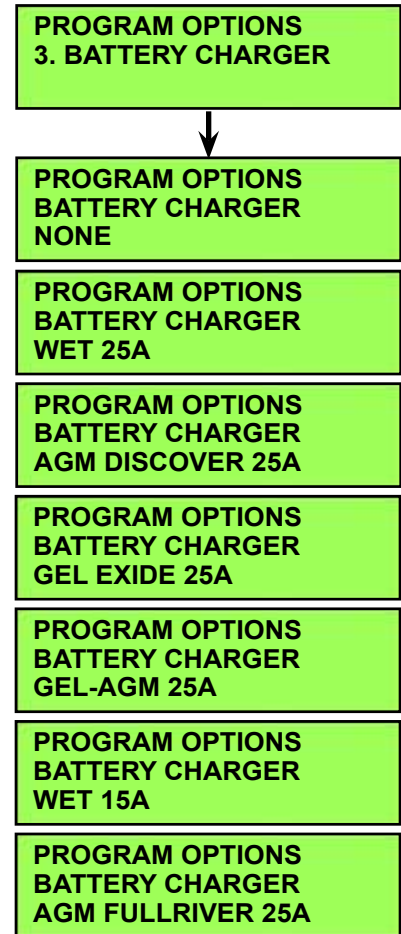

Burst Of Power Operation

The SA40 machine does not support Burst of Power. So this menu item is not functional at this time.

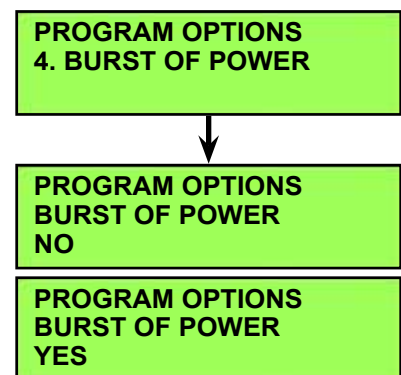

Detergent (EcoFlex™) Option

The SA40 does not utilize a separate detergent system. So this menu item is not applicable at this time. The menu choice must be set to “No”.

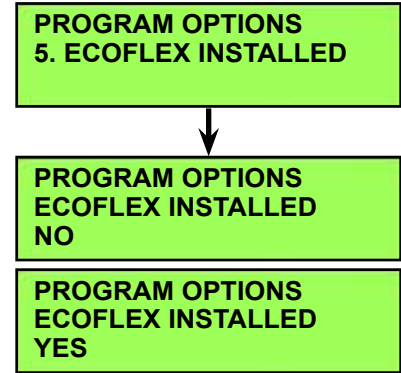

Chemical Rate Bias

The SA40 does not utilize a separate detergent system. So this menu item is not applicable at this time.

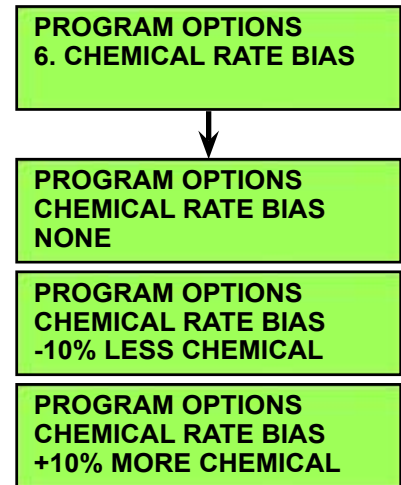

Open Fault Detect

Normally, the A1 Control Board will perform checks of the electrical system during operation. If a fault occurs in a particular system, that system (and possibly others) will be shut down. This can make troubleshooting the system difficult. The **7. OPEN FAULT DETECT** submenus allow service personnel to disable all of the open circuit faults to facilitate troubleshooting. Note that selecting **OPEN FAULT DETECT / OFF** will not disable the over-current protection on any of the systems.

The default setting is **OFF**.

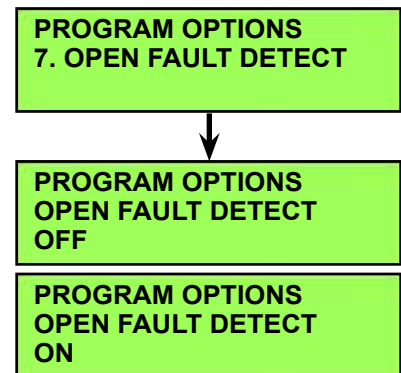

Display Rev Level

The **8. DISPLAY REV LEVEL** submenu displays the revision level of the software in the A1 Control Board. This revision level is a parameter hard-coded in the software.

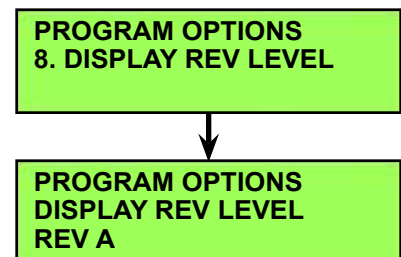

Lock Out Brush Pressure

The **9. LOCKOUT BRUSH** submenus allow you to lock out the low or high scrub pressure settings. The Operator will not be able to select a scrub pressure setting that is locked out.

The default setting is **NONE**.

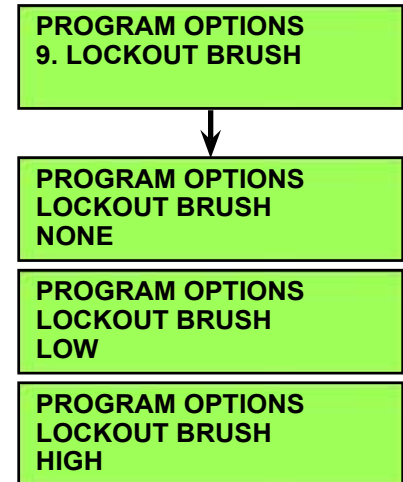

Lock Out Solution Flow Rate

The **10. LOCKOUT SOLUTION** submenus allow you to lock out single or multiple solution flow rate settings. The Operator will not be able to select flow rate(s) that are locked out during normal operation.

The default setting is **NONE**.

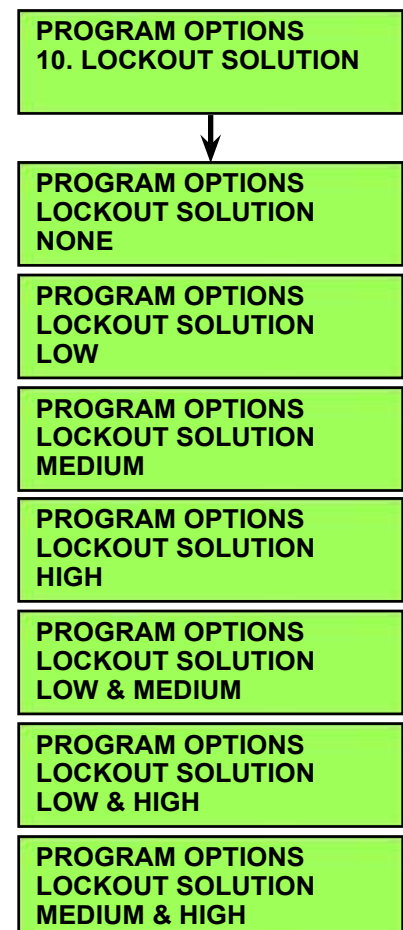

Backup Alarm Volume

The **11. BACKUP ALARM VOL** (volume) submenus allow you to set the backup alarm volume.

The default setting is **MEDIUM**.

Forward Alarm Volume

The **12. FWD (forward) ALARM VOL** (volume) submenus allow you to set the forward alarm volume.

The default setting is **OFF**.

Horn Volume

The **HORN VOLUME** submenus allow you to set the horn volume.

The default setting is **HIGH**.

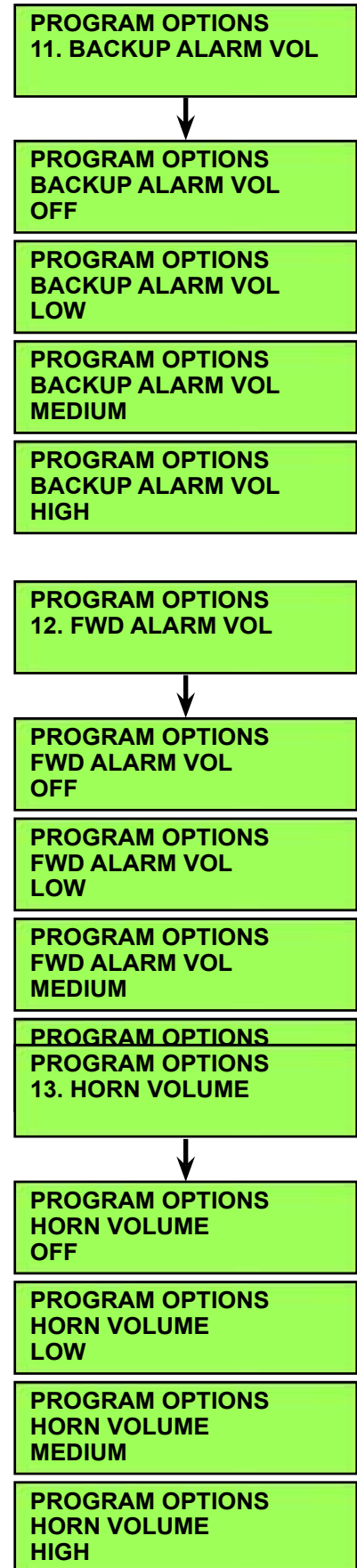

Restore Defaults

The **14. RESTORE DEFAULTS** submenus allow you to reset the programmed options/parameters stored in the A1 Control Board EEPROM to their factory default values. Note that selecting **RESTORE DEFAULTS / YES** will not reset the hour meter.

The default setting is **NO**.



Note: If you select **YES** to restore the defaults, it will be like installing a new “out of the box” controller. The first time you turn on the key switch, the graphic display will automatically bring you to the programming options menu. Also any “user preferences” like brush pressure lock out or solution flow rate lock out will be lost.

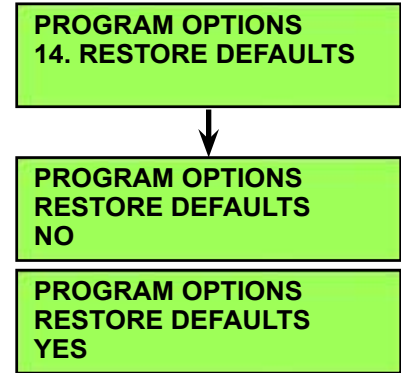

Fault Recall

Whenever the A1 Control Board detects an electrical system fault, one or more error codes are displayed and stored in the Board EEPROM. The **15. FAULT RECALL** submenu allows you to recall any error code(s) that had been logged from previous machine operation. This can be useful for troubleshooting the machine.

- Any logged fault codes will be shown on the display. (Fault codes **3, 32** and **52** are shown here in this example.)
- If no fault code is present, the display will show a “-“

Pressing the Information Switch with the **FAULT RECALL** submenu displayed will erase the fault history and the entire Frozen Parameters memory. (Refer to “[Frozen Parameters](#)” on page 39.)

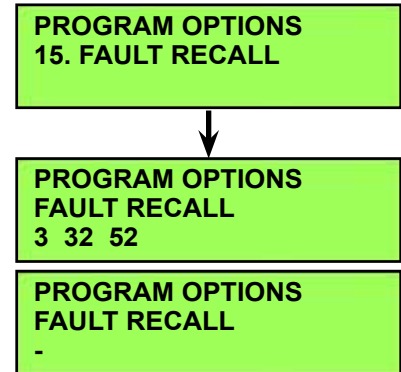

Note that there may be a slight delay after pressing the Information Switch before the “-“ symbol appears to confirm that the memory has been cleared. This is normal and is due to the large amount of Frozen Parameter data that is being erased.

Service Test Mode

The **16. SERVICE TEST MODE** allows you to switch the individual electrical system components on and off independent of the normal Operator inputs. This function is described in the Troubleshooting section on [page 29](#).

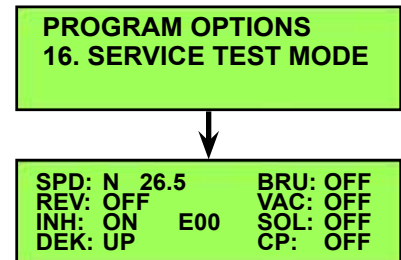

Extra Information on the Graphic Display

The **17. EXTRA INFO ON LCD** submenus allow you to display additional information on the graphic display. This additional information is displayed in real time on both the Scrubbing and Information screens and can aid in troubleshooting the machine in normal operation.

The extra information is displayed in a two-letter or three-letter code that identifies the information. A number below the letter code indicates the unit value in amps or volts.

Only one type of extra information can be displayed at any time, but the selected information can be changed at will via the **17. EXTRA INFO ON LCD** submenus. Descriptions of the letter codes are as follows:

- **BV** = Battery Voltage
- **LOK** = Battery Lock Level
- **ACT** = Deck Actuator Current
- **SOL** = Solution Solenoid Current
- **BRU** = Brush Motor Contactor Current
- **VAC** = Vacuum Motor Contactor Current
- **DET** = Detergent/Chemical Pump Current

The default setting is **NONE**.

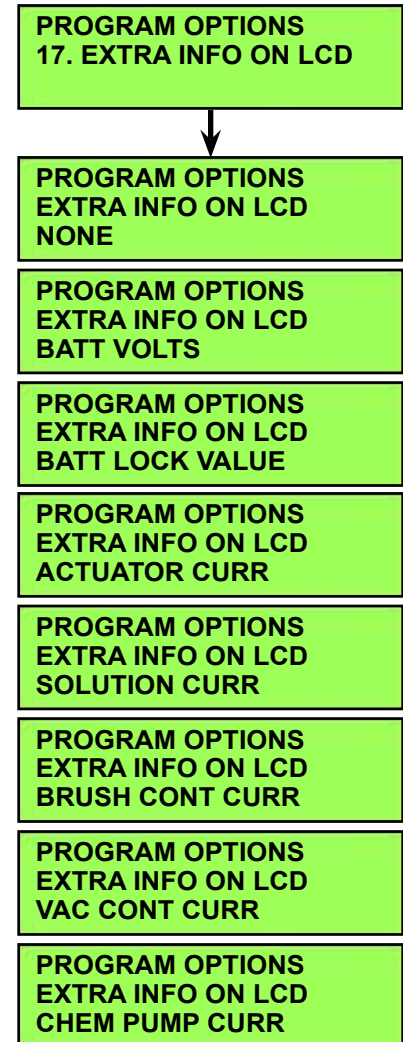

Frozen Parameters

The **18. FROZEN PARAMETER** first and second-level submenus allow you to view the machine parameters that were saved prior to when an error code was detected. This can be helpful when troubleshooting intermittent problems that are causing a code to set.



Note: *Frozen parameters are only saved for the first code that is set, not for any subsequent codes.*

Eleven different machine parameters are logged, and all but the error code number and hour meter time are saved at 0.1 second intervals for the 12.8 seconds leading up to the time of the error code. This results in a total of 128 data points (one every 0.1 seconds) for each parameter. These data points are displayed in a second-level of submenus.

The first-level **ERROR CODE** submenu displays the error code number (**32** in this example). The first-level **HOURL METER** submenu displays the time on the hour meter when the error code occurred (**12:15** in this example). The other nine first-level submenus are links to the next (second) layer of submenus that display the 128 data points corresponding to the functions listed on the submenus.

Note that in the second-level submenus, data point #1 is the newest value and #128 is the oldest value (that occurred 12.7 seconds earlier).

Pressing the Forward (up) or Reverse (down) Drive Switches will scroll through the **18. FROZEN PARAMETER** first-level submenus shown here.

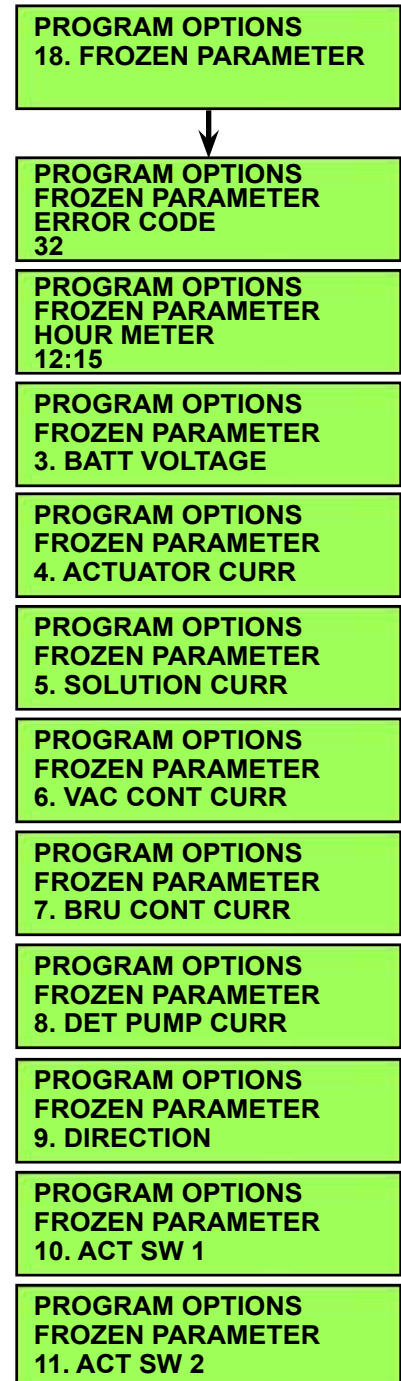

To display the parameter data points in a second-level submenu:

1. Press the Forward (up) or Reverse (down) Drive Switch to scroll through the available first-level submenus. (The first-level submenu **3. BATT VOLTAGE** is selected in this example.)
2. Press the Information Switch to display the second-level submenu. (The second-level submenu **3. BATT VOLTAGE / 1: 20.35** is shown in this example.) This submenu tells you that at data point **1** (0.1 seconds prior to the error code), the battery voltage was **20.35** volts.
 - Note that if the selected first-level submenu has no second-level submenu, the Information Switch will have no effect.
3. To go back one level from a second-level submenu to a first-level submenu, press the Scrub On/Off Switch.

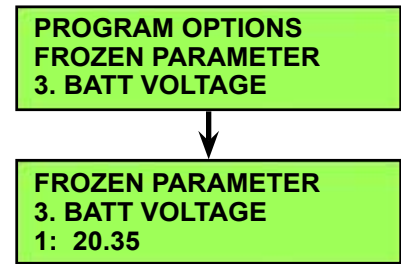

To scroll through the data points on a second-level submenu:

When you display a first-level submenu, the Brush Pressure Indicator (LED) will turn on.

When you display a second-level submenu, pressing the Brush Pressure Switch will toggle the data point scrolling mode between the fast and slow scrolling modes. The two scrolling modes work as follows:



- In the slow scrolling mode the increment/decrement value is 1 (0.1 seconds). Pressing the Forward Drive Switch will step you from data record 1 to 2, 2 to 3, etc. Pressing the Reverse Drive Switch will step you from data record 128 to 127, 127 to 126, etc.
- In the fast scrolling mode the increment/decrement value is 10 (one second). Pressing the Forward Drive Switch will step you from data record 10 to 20, 20 to 30 etc. Pressing the Reverse Drive Switch will step you from data record 120 to 110, 110 to 100, etc.

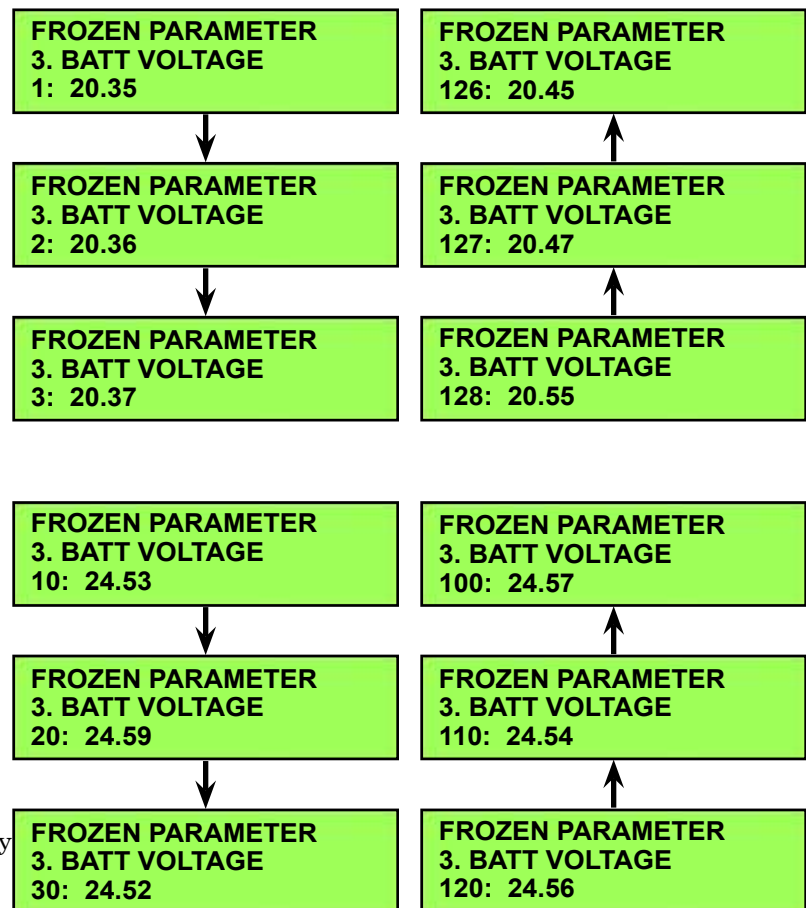

The purpose of the fast-scrolling feature is to reduce the number of switch presses required to cycle through all 128 data points if you choose to do so.

This fast-scrolling feature will automatically end when you press the Scrub On/Off Switch to leave a second-level submenu.

The Brush Pressure Indicator will turn off when you press the Scrub On/Off Switch again to leave the first-level submenu.

To capture the parameters prior to another fault condition, you'll need to clear the current fault from the **15. FAULT RECALL** submenu. (Refer to ["Fault Recall"](#) on page 37.)

Panel Test



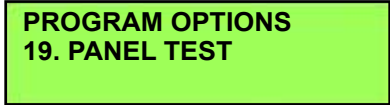



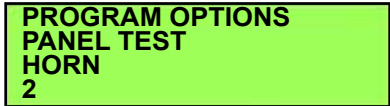

The **19. PANEL TEST** submenus allow you to verify the function of the control panel membrane switches and LEDs, This will help identify any intermittent or non-functioning switches or LEDs. When the submenu is first entered, all LED will turn off



When you press a membrane switch, the display will show the name of the switch and how many times its press was recorded. The display shows that the **HORN** Switch has been pressed twice in this example.



When a switch is pressed, its associated LED will illuminate. The LED will remain illuminated until a different switch is pressed or the menu is exited. Because the Horn and Information Switches do not have LED indicators, the vacuum mode indicators are used, as described in the table below.

Membrane Switch	LED Indicator That Will Light When the Switch is Pressed
Horn Switch 	Quiet Vacuum Mode Indicator on the Vacuum Power Adjustment Switch 
Information Switch 	Standard Vacuum Mode Indicator on the Vacuum Power Adjustment Switch 
Vacuum Power Adjustment Switch 	Both Quiet & Standard Vacuum Mode Indicators on the Vacuum Power Adjustment Switch 
Scrub Switch 	Both the Scrub Switch and Scrub Pressure LEDs will illuminate. 
All Other Switches	Their respective On/Off Indicator

Save Scrub Settings

The **20. SAVE SCRUB SETTINGS** submenus allow you determine whether the machine uses the scrub settings that were in use when the key switch was switched off, or the default settings.

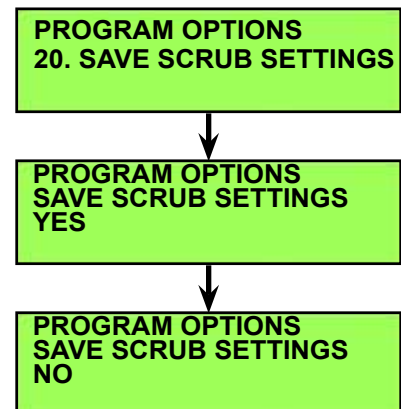

Removal and Installation

A1 Control Board



Caution! Electronic devices like the A1 Control Board are sensitive to Electrostatic Discharge (ESD). Before handling the Control Board, touch a metal bench or shelf to discharge any electrical charge that may have built up in your body. Do not walk around with a Control Board in your hands.

1. Disconnect the batteries.
2. Remove the four **Phillips Screws and Flat Washers** holding the **Interface Panel Assembly** to the **Control Panel**.



3. Carefully lift the **Interface Panel Assembly** out of the **Control Panel**.

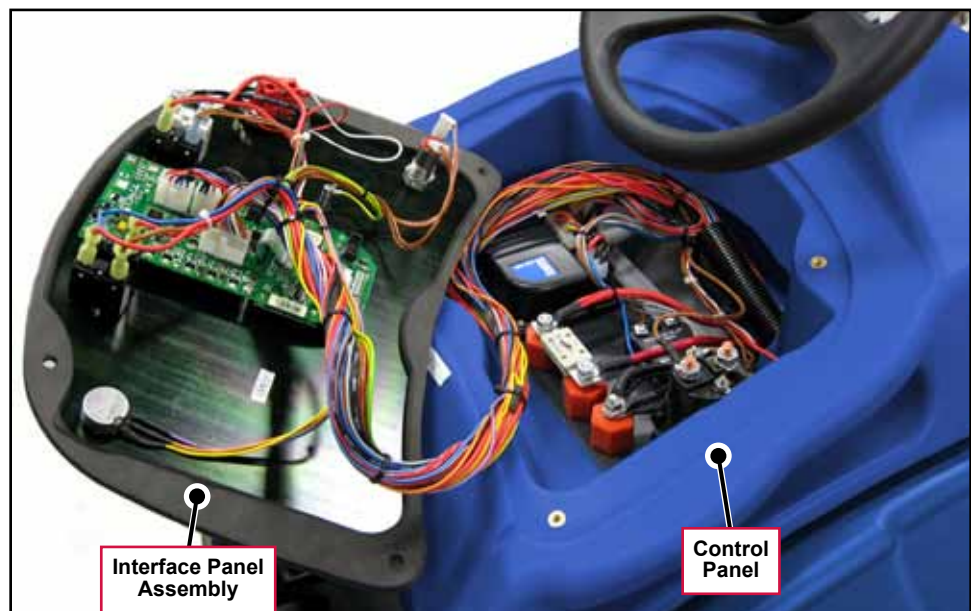

4. Carefully disconnect the **Electrical Connectors** from the **A1 Control Board**.
5. Remove the **Phillips Screws** and grounding strap, then remove the **A1 Control Board** from the **Interface Panel Assembly**.
6. Reinstall the **A1 Control Board** by following the above steps in reverse order.

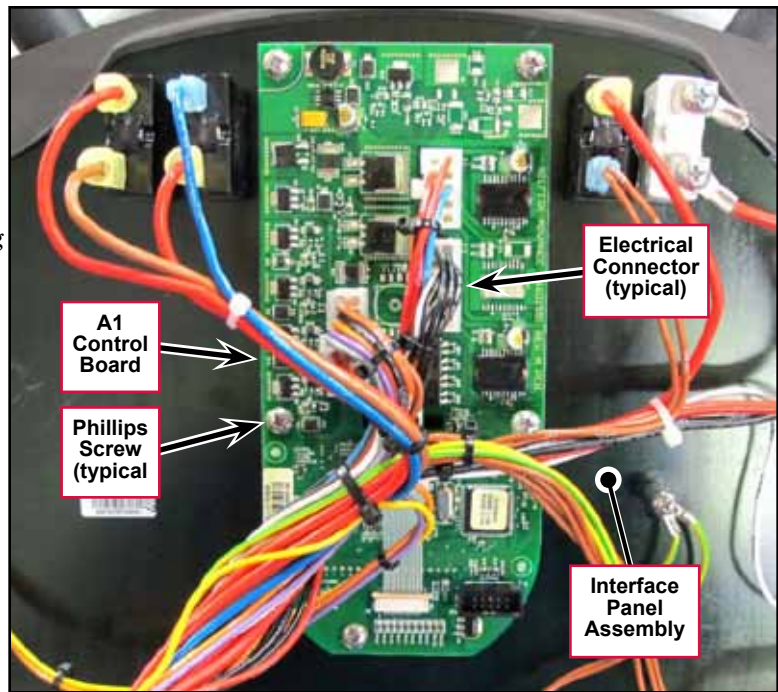

E1 Curtis 1210 Speed Controller

1. Disconnect the batteries.
2. Remove the four **Phillips Screws** and **Flat Washers** holding the **Interface Panel Assembly** to the **Control Panel**.



3. Carefully lift the **Interface Panel Assembly** out of the **Control Panel**.

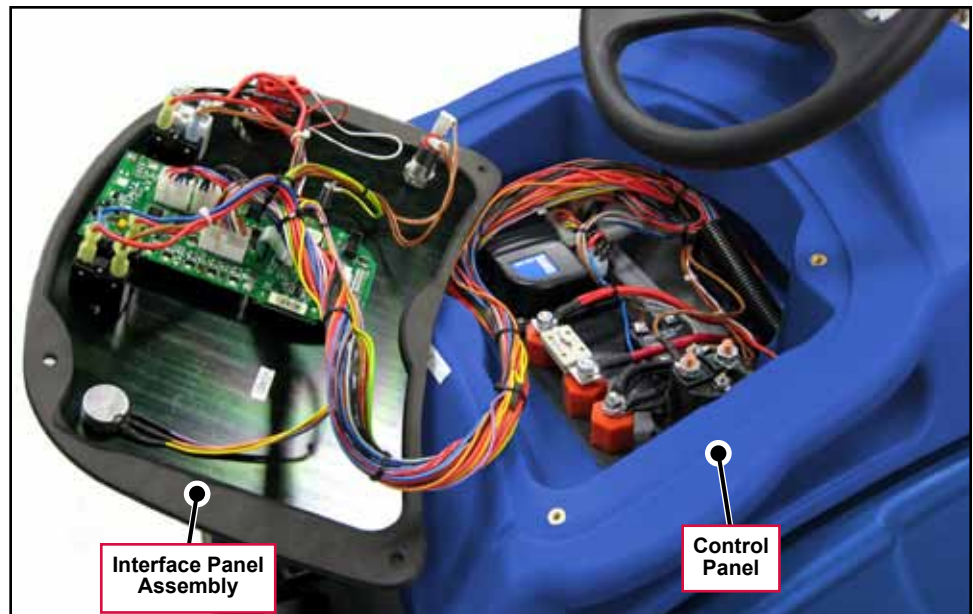

4. Carefully disconnect the **Electrical Connectors** from the **E1 Curtis 1210 Speed Controller**.
5. Remove the two **Socket Head Screws** and remove the **E1 Curtis 1210 Speed Controller** from the **Control Panel**.
6. Reinstall the **E1 Curtis 1210 Speed Controller** by following the above steps in reverse order.

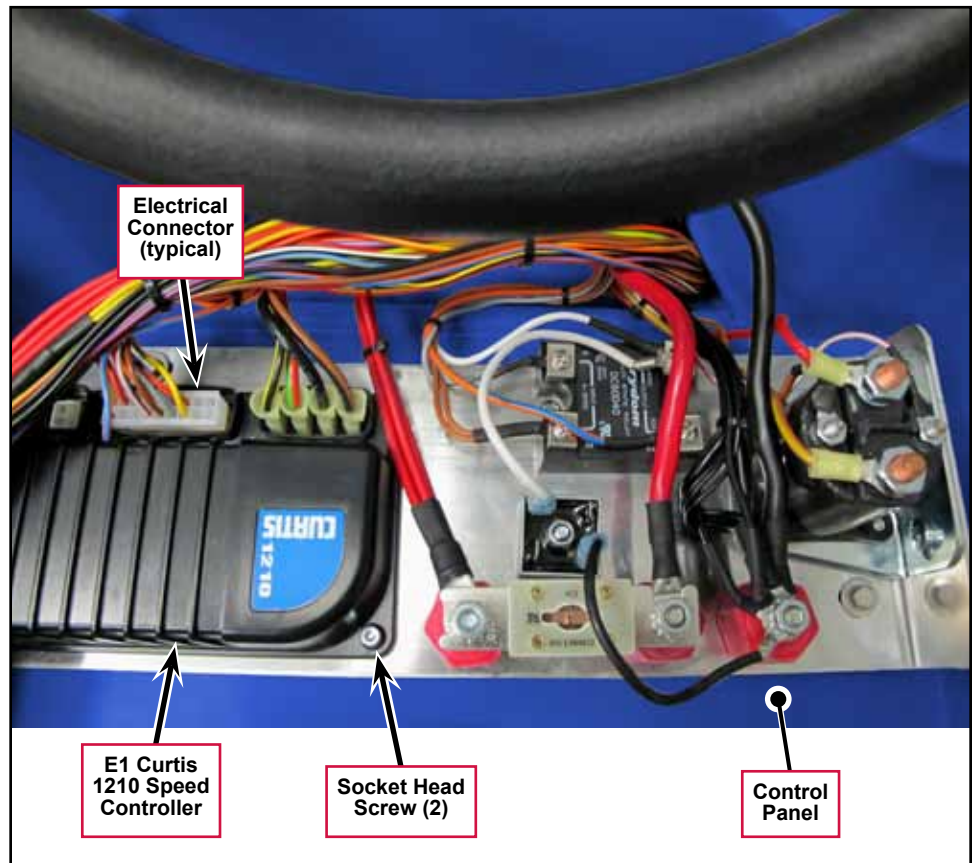

A1 Control Board Shop Measurements

The following table lists measurements taken from one SA40 machine. While these are not “specifications”, they can help you recognize abnormal vs. normal conditions.

Note that the black voltmeter lead is on B- unless otherwise indicated.

Pin	Color	Description	Ref.	Measurements
J1-1	RED/YEL	Chemical Pump +	B-	2.1v not on
J1-2	-			
J1-3	BLU/GRY	Chemical Pump	B-	2.1v not on
J1-4	-			
J1-5	-			
J1-6	-			
J1-7	RED/YEL	Inhibit SPC	B-	0.001v no direction selected 23.2v FWD or REV requested
J1-8	BLK		B-	0.09v Vacuum on
J1-9	BLU	Brush Act. -	B-	2.1v or 3.8v at rest 0.2v extending 22.9v retracting
J1-10	ORN/BLK	Brush Act. +	B-	2.1v or 3.8v at rest 0.2v retracting 22.9v extending
J2-1	BLK	B-	B-	0.09v Vacuum On
J2-2	BLK	B-	B-	0.09v Vacuum On
J2-3	ORN	Batt. Chg. Comm.	B-	0.8v key off Plug in Charger: 12v, then 3.9v, then 12 v
J2-4	-			
J2-5	-			
J2-6	-			
J2-7	BLK	B-	B-	0.09v Vacuum On
J2-8	BLK	B-	B-	0.09v Vacuum On
J2-9	-			
J2-10	-			
J2-11	BLK/WHT	Act. Position 2	B-	4.99v switch open 0.03v switch closed
J2-12	RED/VIO	Act. Position 1	B-	4.99v switch open 0.03v switch closed
J3-1	BRN/VIO	B+	B-	24.5v key off or on
J3-2	-			
J3-3	RED/BRN	Reverse	B-	0v no direction request or forward request 23.1v reverse direction request
J3-4	BRN	Dead Man Switch	B-	24.4v when pressed (Key and Emergency Switch also closed)
J3-5	BLU/BLK	Rev. Alarm	B-	23.4v forward or stationary 1.5v in reverse
J3-6	RED/WHT	Motion	B-	24v stationary 0.1v moving forward or reverse

Pin	Color	Description	Ref.	Measurements
J3-7	ORN/BLU	Status	B-	1.77v when no code Unstable when code – max 23.5v
J3-8	BRN	B+	B-	24.4v key off or on
J3-9	GRN/BLK	Horn -	B-	14.9v horn off 0.004v horn on
J3-10	ORN/RED	Horn +	B-	14.9v horn off or on
J3-11	VIO/BLK	Solution Solenoid	B-	24.4v solenoid off 0.12v solenoid on
J3-12	GRA/BLK	Vacuum Control	B-	23.4v Vacuum off 6.9v Vacuum low 0.104 Vacuum high
J3-13	WHT/RED	Brush Contacator	B-	24.3v off 0.2v on
J3-14	BRN	Key Switch	B-	0v key off 24.2v key on

Electrical System

Functional Description

Overview

The electrical system consists of the switches, circuit breakers and contactors mounted on and underneath the control panel assembly, the 150-amp main fuse, on-board battery charger (if so equipped) and the batteries.

The electrical system is powered by two 12-volt or four 6-volt batteries for a total of 24 volts. Heavy cables connect the batteries in series. On machines without an on-board battery charger, a large red main battery pack connector is used for connecting the batteries to a “shelf” battery charger unit.

The control system will turn off the scrub system and recovery systems if the battery voltage drops too low to prevent damage to the batteries due to excessive discharging.

The circuit breakers and a 150-amp fuse protect various circuits from excessive current.

The machine wiring is color coded, and the wires are marked corresponding to their location on the “[Wiring Harness Diagram](#)” on page 57. (Wire **W010** to the Brush Contactor K2 is shown in this example.)



On-board Battery Charger

An optional on-board battery charger is mounted on the bottom of the machine.



Delta-Q Charger

Interlock Circuit

The battery charger has an “interlock circuit” which consists of an internal relay that interrupts the “Deadman” signal to the main control board, and the Keyswitch Input (KSI) signal to the drive speed controller when the charger is plugged into an AC power outlet. This prevents the machine from being propelled while the batteries are charging.

Here is how the battery charger interlock circuit works. The interlock relay contacts inside the charger are normally closed, allowing positive control voltage to be present in the Keyswitch, E-Stop, and Deadman circuit. When all switches are closed, positive voltage is applied to the enabling inputs of the A1 Control Board and the Speed Controller. When the AC power cord is plugged in, the relay is energized and opens the relay contacts opening the circuit.

Charger Interlock Circuit, Not Plugged In

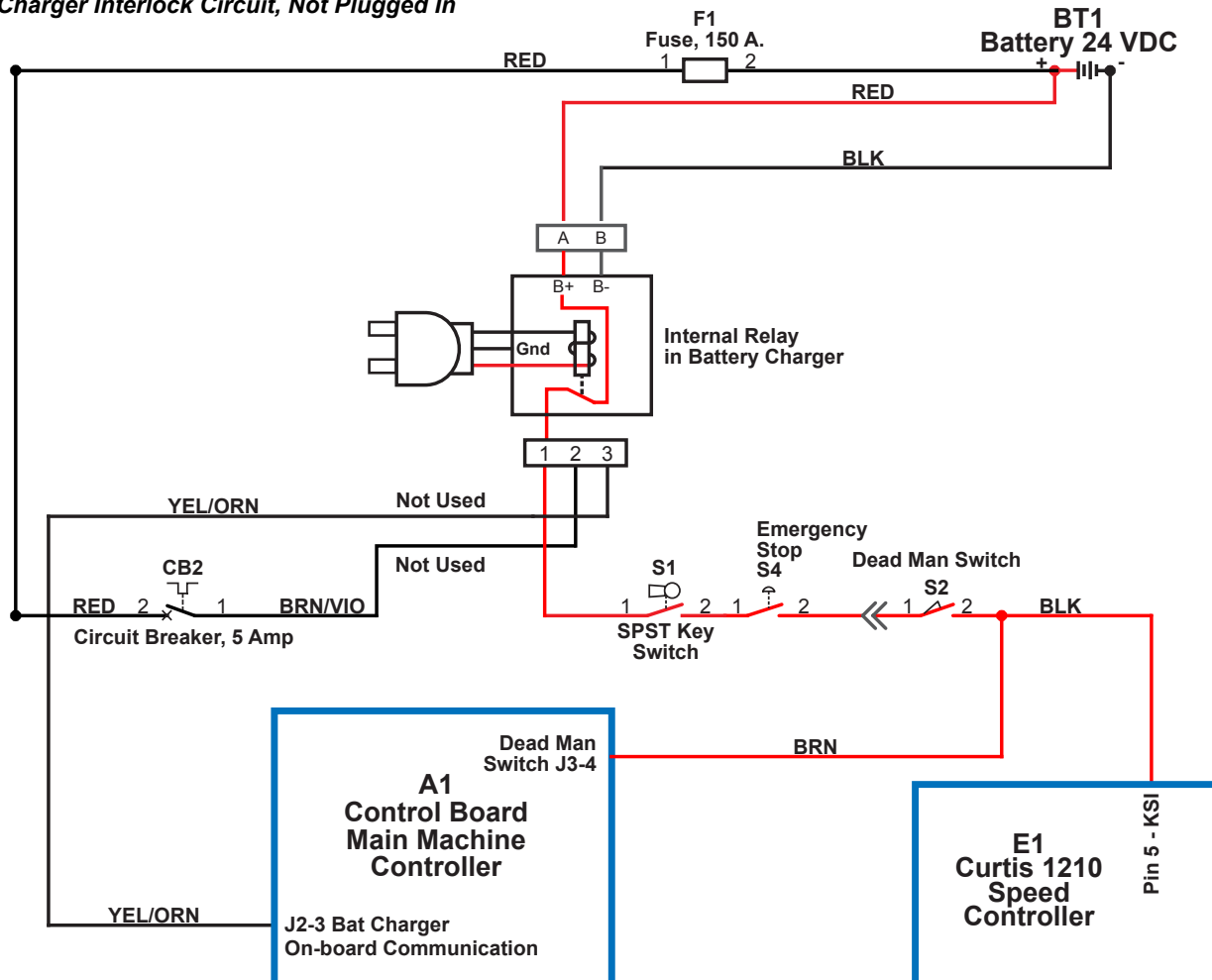

Charter Interlock Circuit, Plugged In

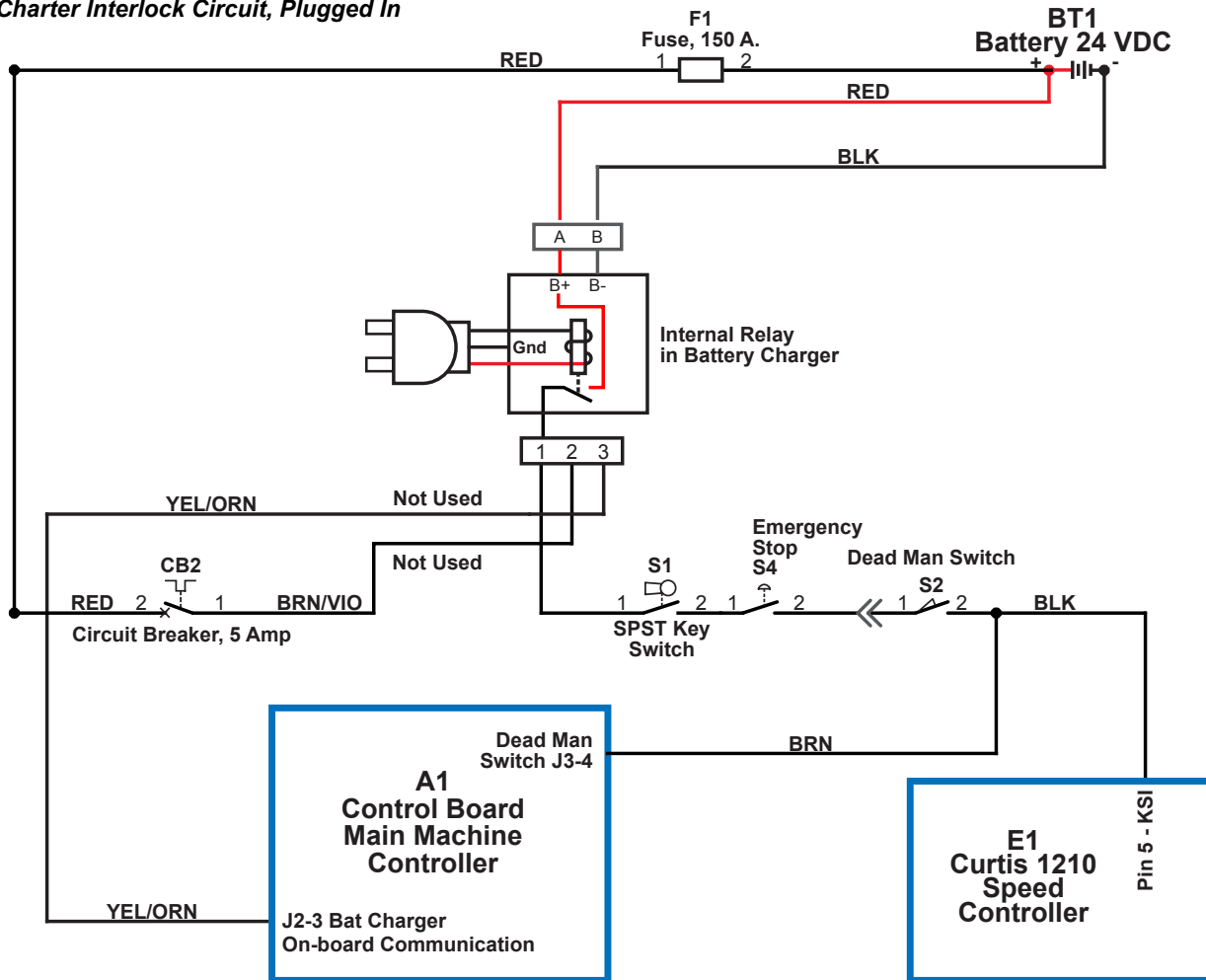

Delta-Q Charging Profiles and Charging Progress

The Delta-Q battery charger does not communicate with the main machine controller. It is a “stand-alone” unit. Models that have the Delta-Q charger have a separate LED to communicate charging progress. By pressing a button on the charger you can see what charging profile is in use. If you replace the batteries with a different type of battery or replace the battery charger, you must select the correct charging profile to be compatible with the batteries. There are a set of profiles stored inside the charger. You can interface directly with the charger to select the profile to be used from that set. See the Delta-Q IC650 Product Manual (710-0138-Delta-Q.pdf) for complete instructions on selecting the profile. Use the Delta-Q Battery Charging Profile Table below to choose the profile to match the batteries that are in the machine.

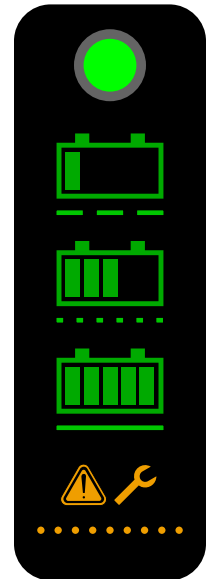

Delta-Q Battery Charging Profile Table

Battery Manufacturer	Volts	Battery Model #	20 Hour Rating	N-A P/N	Use Profile
DISCOVER	6	EV250A-AGM	260	40953A	P-0-4-3
DISCOVER	6	EV305A-A	312	56112546	P-0-4-3
DISCOVER	6	EV305A-A	312	56315959	P-0-4-3
DISCOVER	6	EV305A-AGM	312	40964A	P-0-4-3
DISCOVER	6	EVGT6A	255	56112545	P-0-4-3
DISCOVER	6	EVGT6A	255	56315772	P-0-4-3
DISCOVER	6	EVL 16A-A	390	56388582	P-0-4-3
DISCOVER	12	EV12A-A	140	56380239	P-0-4-2
DISCOVER	12	EV185A- A	234	56393912	P-0-4-3
DISCOVER	12	EV185A-A	234	41023A	P-0-4-3
EAST PENN MFG. CO.	6	8GGC 2/T881 (GEL CELL)	180	56206987	P-0-2-6
EAST PENN MFG. CO.	12	8G27MM/T876	86.4	56206988	P-0-2-6
FULL RIVER	6	DC 250-6	250	56112545	P-1-5-1
FULL RIVER	6	DC 335-6	335	56112546	P-1-4-1
TROJAN	6	J -305G	285	56391391	P-0-0-7
TROJAN	6	J-250-2992-41	250	56026200	P-0-0-3
TROJAN	6	L16-5592-41	395	56388582	NOT RECOMMENDED
TROJAN	6	T-125LPT	235	56206079	P-0-0-3
TROJAN	6	T-605LPT	195	56206117	P-0-0-3
TROJAN	12	J185-2292-42	195	56206078	P-0-0-3
US BATTERY	6	L16	375	40602A	P-0-7-3
US BATTERY	6	L16	375	40704A	P-0-7-3
US BATTERY	6	L16HC	415	56388582	P-0-7-3
US BATTERY	6	US-125	235	331318	P-0-1-1
US BATTERY	6	US-125	235	881317	P-0-1-1

Battery Manufacturer	Volts	Battery Model #	20 Hour Rating	N-A P/N	Use Profile
US BATTERY	6	US-125	235	56206079	P-0-1-1
US BATTERY	6	US-125	235	40136A	P-0-1-1
US BATTERY	6	US-125	235	40136B	P-0-1-1
US BATTERY	6	US-14 5XC	251	56317154	P-0-7-2
US BATTERY	6	US1800	201	56206117	P-0-1-1
US BATTERY	6	US250HC	275	56026200	P-0-1-1
US BATTERY	6	US-305	305	891384	P-0-7-2
US BATTERY	6	US-305	305	891385	P-0-7-2
US BATTERY	6	US-305	305	56391391	P-0-7-2
US BATTERY	12	UB27	86	40070A	P-0-0-6
US BATTERY	12	US-185	195	871334	P-0-1-1
US BATTERY	12	US-185	195	871335	P-0-1-1
US BATTERY	12	US-185	195	56206078	P-0-1-1
US BATTERY	12	US-31TMX	130	40605A	P-0-7-1
US BATTERY	12	US-31TMX	130	40606A	P-0-7-1

Component Locations

The following electrical components are included in this section:

- Batteries
- Switches
- Contactors/Relays
- Optional On-board battery charger
- Circuit Breakers
- 150-amp Fuse

The **Batteries** sit in the **Battery Tray**. To access the **Batteries**, lift up the **Control Panel Housing / Recovery Tank Cover**, engage the **Prop Rod**, then tilt the **Recovery Tank** back.

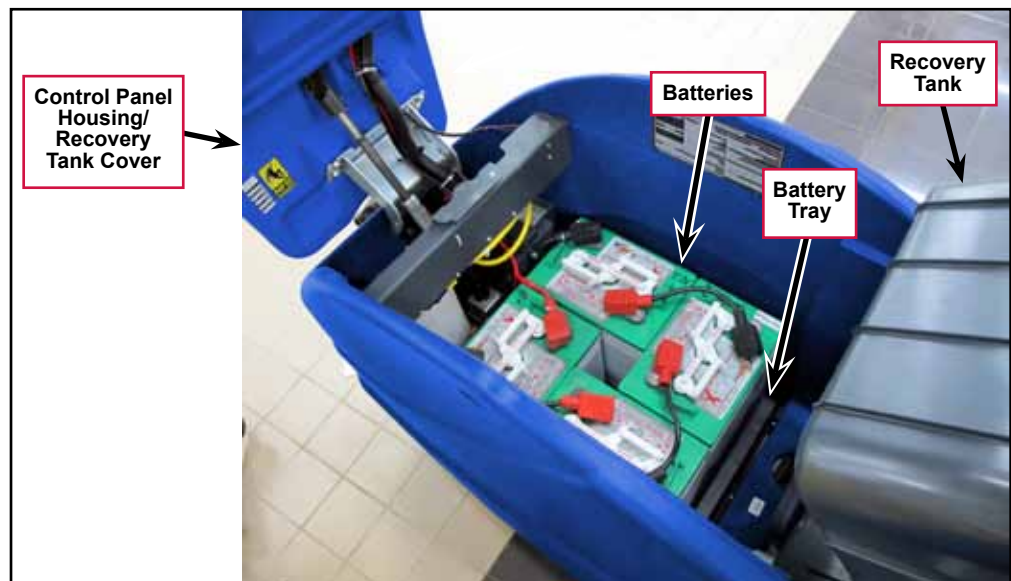

The **On-board Battery Charger** is mounted on the underside of the machine above the scrub deck.



The **25-amp Circuit Breaker (CB4)**, **20-amp Circuit Breaker (CB3)**, **5-amp Circuit Breaker (CB2)** and **50-amp Circuit Breaker (CB1)**, **100k Speed Control Potentiometer (R1)**, **Emergency Disconnect** and **Key Switch (S1)** are all mounted on the back of the **Control Panel**.

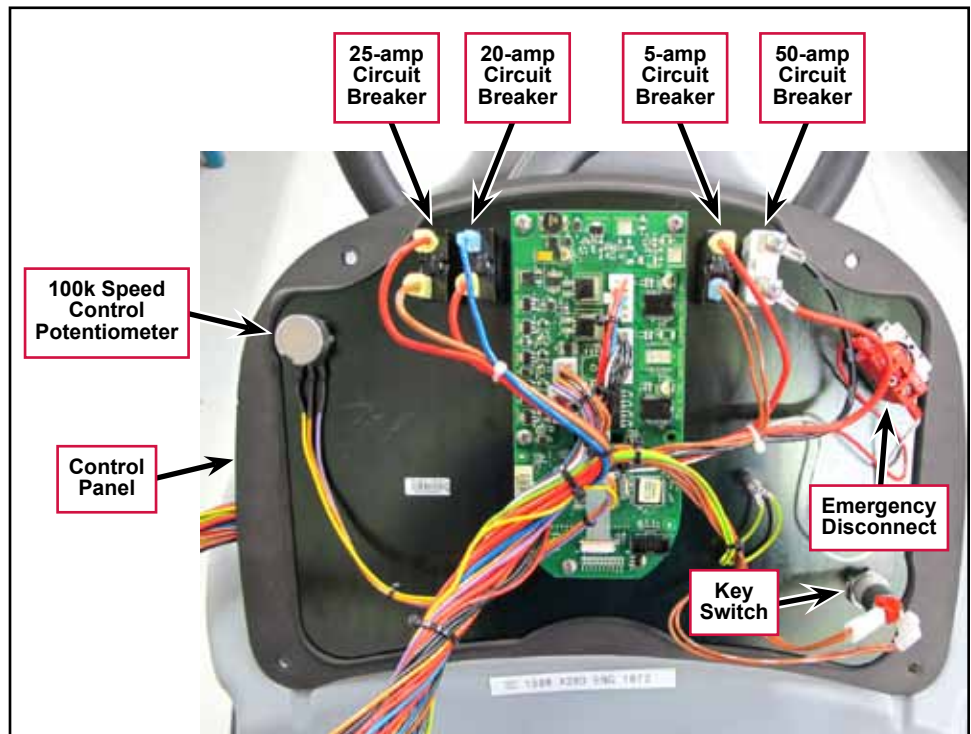

The **Solid State Relay (K1)**, **Brush Motor Contactor (K2)**, **Fly-back Diode (D2)** and **150-amp Fuse** are located inside the control panel assembly.

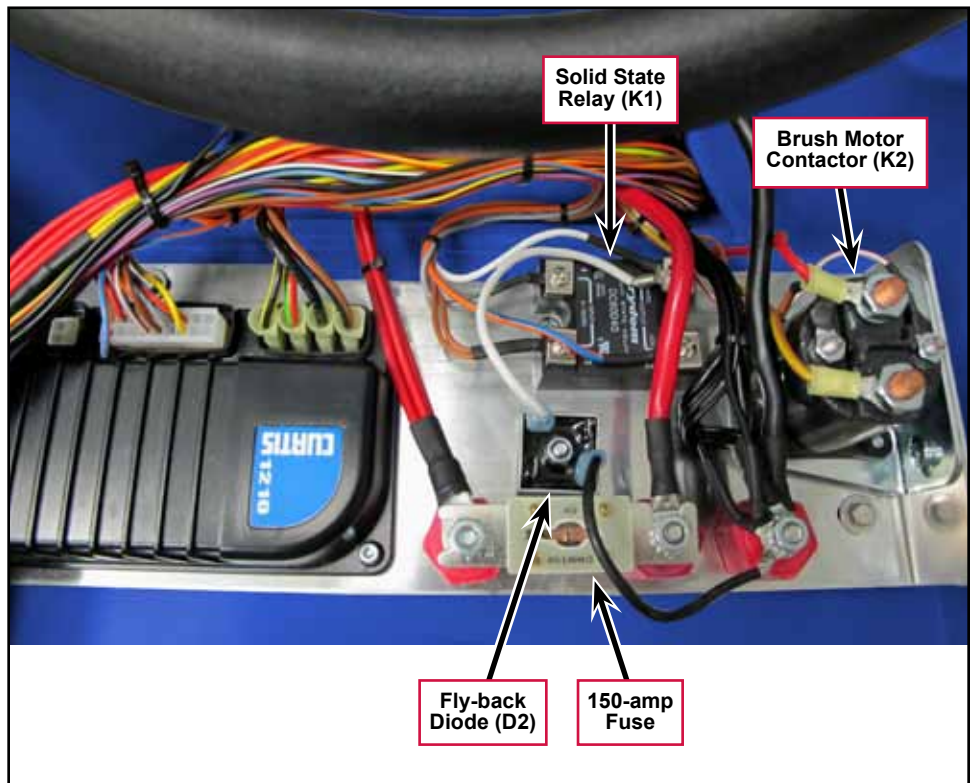

Troubleshooting



Refer to the individual machine system sections for electrical troubleshooting procedures.

Problem	Cause	Correction
No power to the machine.	Discharged batteries.	Check the battery voltage and charge as necessary.
	Poor battery connection(s).	Check the battery cables, terminals and connections and tighten/repair/replace as necessary.
	Batteries need to be replaced.	Perform a load test on the batteries and replace if necessary.
Insufficient machine run time.	Incorrect low-voltage cutout setting.	Make sure the low battery voltage cutout setting is correct for the battery type in the machine. (Refer to the Control System/Programming Options/Low Battery Voltage Cutout subsection.)
	Batteries not fully charged.	If there is any question whether the batteries are fully charged, they should be charged for at least 16 hours.
	One or more weak batteries.	<ul style="list-style-type: none"> • Measure the voltage across each individual battery while operating the machine. Write down the values and compare them. A battery that has a dead cell will typically be 1 - 2 volts lower than the others. • Use a battery load tester to test each battery. • For wet batteries, a hydrometer can be used to check the specific gravity of the electrolyte in each cell. A dead cell is one that reads 50 points or more lower than the other cells.
	Poor battery connection(s).	Check the battery cables, terminals and connections and tighten/repair/replace as necessary.
The battery charger does not charge.	Battery charger not operating correctly.	<ol style="list-style-type: none"> 1. Check the charger 120VAC power cord and power source to the charger and repair as necessary. 2. If the electrical connections are OK, replace the charger.
	There's a problem with the charger wiring and/or connections.	Check the charger connections to the machine and repair as necessary.
	One or more weak batteries	Check and replace the batteries as necessary.

Wiring Diagrams

Wiring (Ladder) Diagram

Drawing 56104446, Rev. C

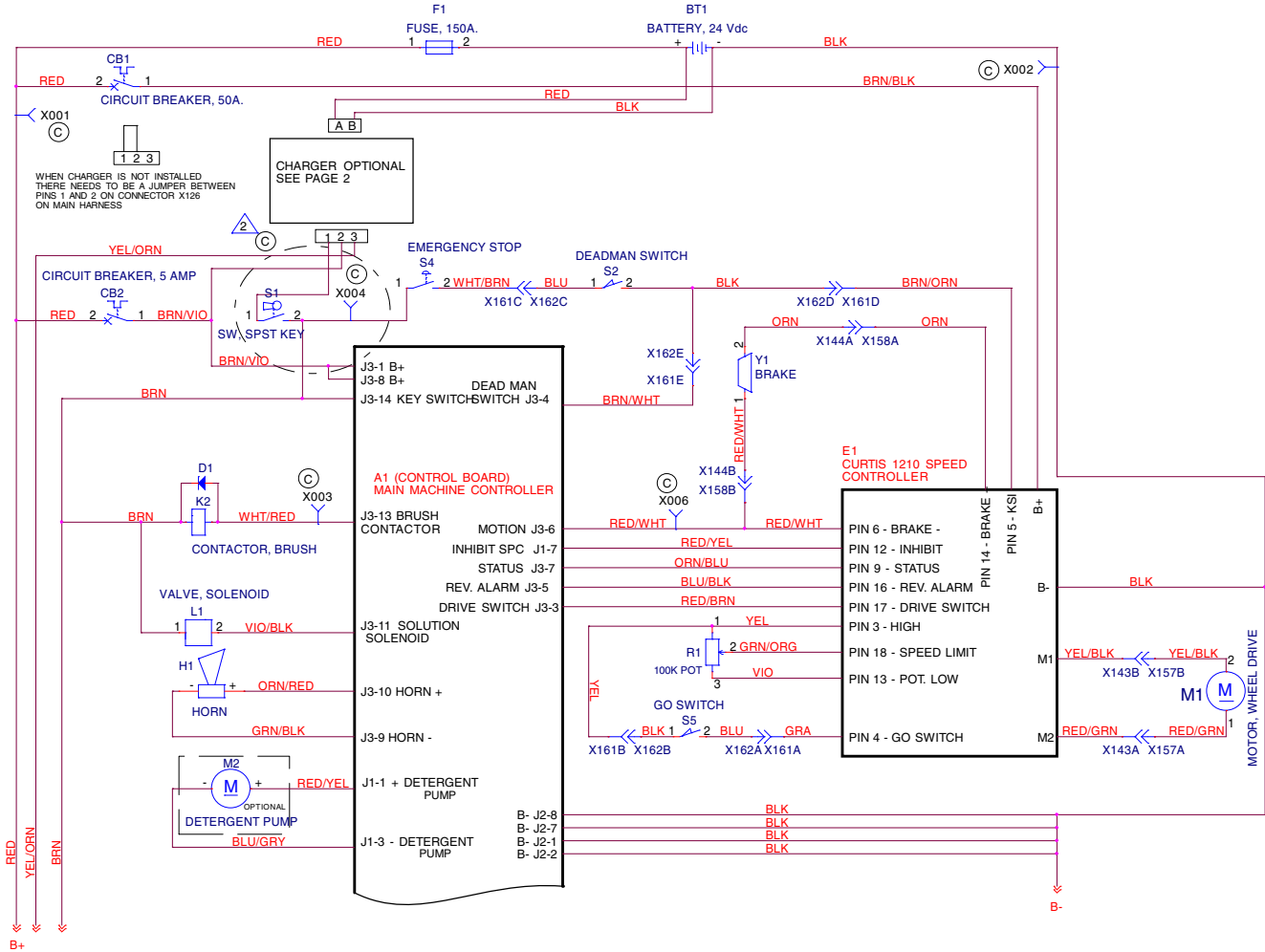

TRACKCLEAN CONNECTIONS (C)

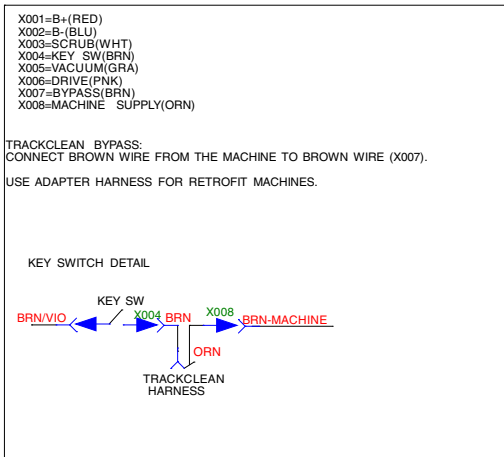

Wiring (Ladder) Diagram, continued

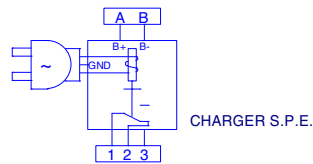
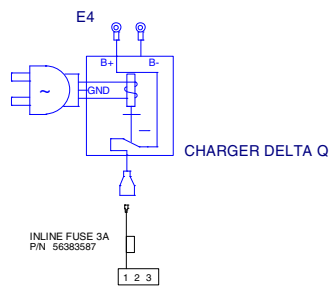
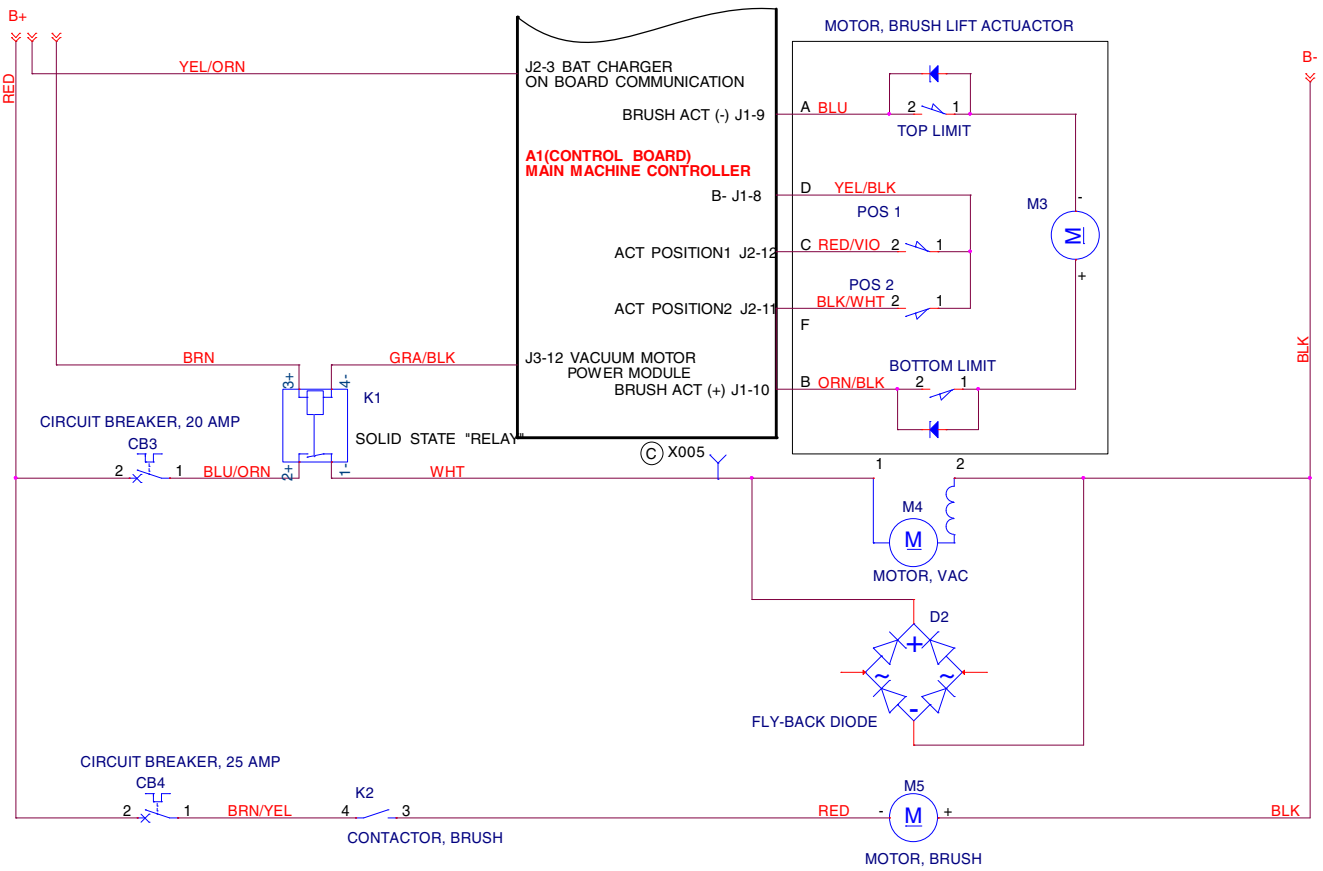

Wiring Harness Diagram

Drawing 56104447, Rev. B

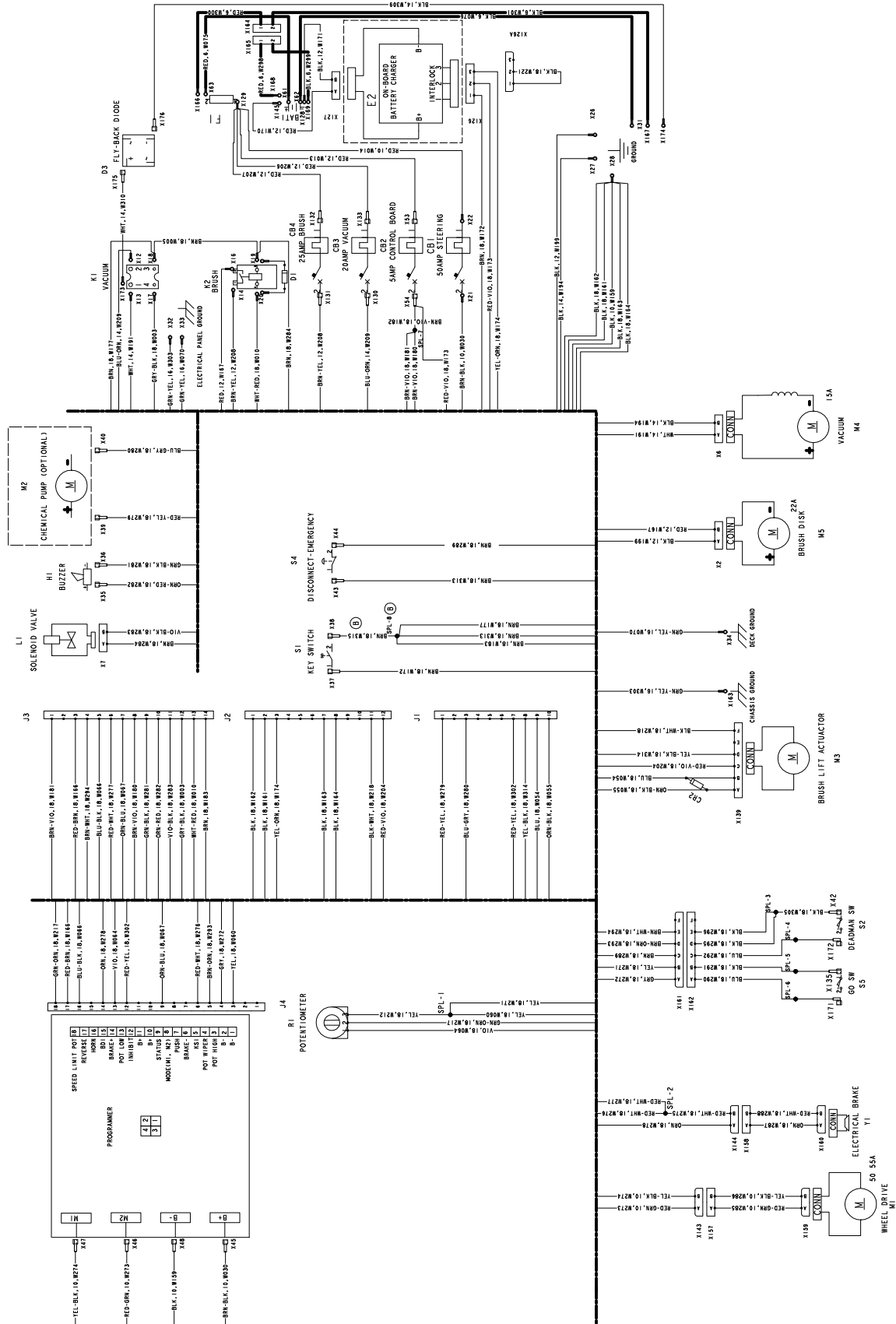

Electrical Connector Pin-out Assignments

The following tables list the individual connector pin-out assignments. The tables include connector illustrations to help you identify the various connectors on the machine. The connector pin-out information is organized by connector ID in alphabetical order.

To Locate and Identify a Connector

For example, if you need to find out which connector is on the **L1 (solution) Solenoid Valve** and what it looks like, refer to the **Wiring Harness Diagram**. The **Wiring Harness Diagram** shows that connector **X7** is on the **L1 (solution) Solenoid Valve**. Refer to the **Wiring (Ladder) Diagram** and the appropriate table below, **X7 (Delphi 12015792)** in this example, for the corresponding wire colors, and wire and connector pin assignments.

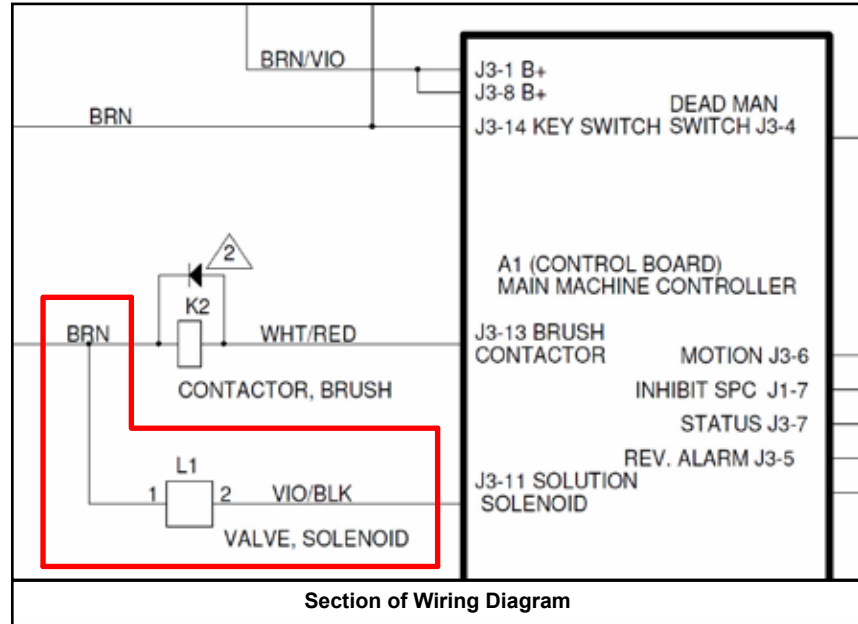
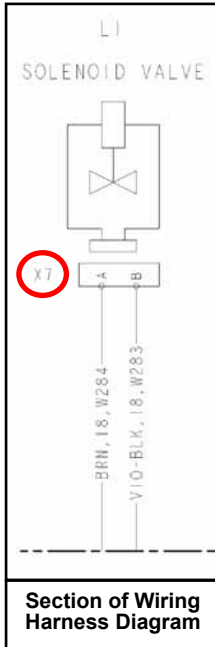

X7 (Delphi 12015792)

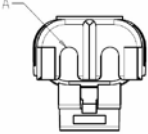
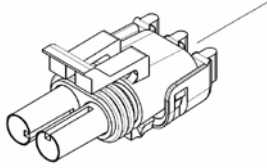
Pin#	Conductor	Wire Color
A	W284	BRN
B	W283	VIO/BLK

Connector Pin-out Assignment Tables

J1 (Molex Mini Fit Jr. 39012105)		
		
Pin#	Conductor	Wire Color
1	W279	RED/YEL
2	–	–
3	W280	BLU/GRA
4	–	–
5	–	–
6		
7	W302	RED/YEL
8	W165	YEL/BLK
9	W054	BLU
10	W055	ORN/BLK

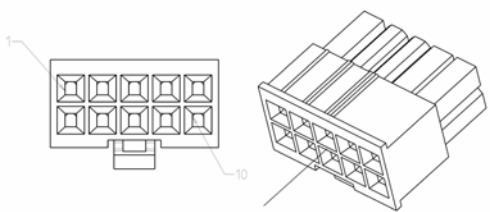
J2 (Molex Mini Fit Jr. 39012125)		
		
Pin#	Conductor	Wire Color
1	W162	BLK
2	W161	BLK
3	W174	YEL/ORN
4	–	–
5	–	–
6	–	–
7	W163	BLK
8	W164	BLK
9	–	–
10	–	–
11	W218	BLK/WHT
12	W204	RED/VIO

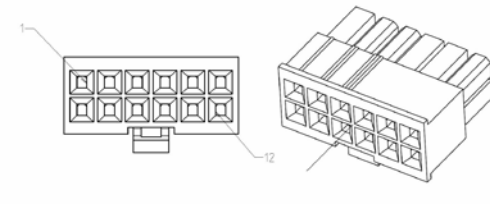
J3 (Molex Mini Fit Jr. 39012145)

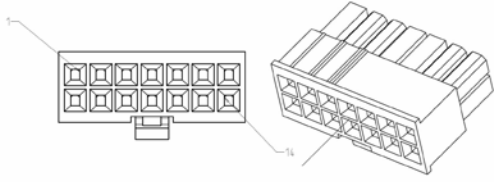

Pin#	Conductor	Wire Color
1	W181	BRN/VIO
2	–	–
3	W166	RED/BRN
4	W294	BRN
5	W066	BLU/BLK
6	W277	RED/WHT
7	W067	ORN/BLU
8	W182	BRN/VIO
9	W281	GRN/BLK
10	W282	ORN/RED
11	W283	VIO/BLK
12	W003	GRA/BLK
13	W010	WHT/RED
14	W183	BRN

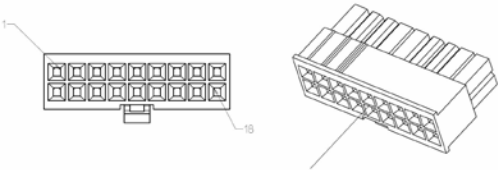
J4 (39012185)		
		
Pin#	Conductor	Wire Color
1	–	–
2	–	–
3	W060	YEL
4	W272	GRA
5	W293	BRN
6	W276	RED/WHT
7	–	–
8	–	–
9	W067	ORN/BLU
10	–	–
11	–	–
12	W302	RED/YEL
13	W064	VIO
14	W278	ORN
15	–	–
16	W066	BLU/BLK
17	W166	RED/BRN
18	W217	GRN/ORN

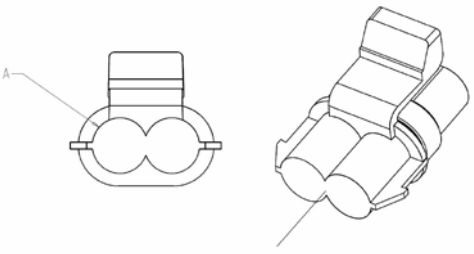
X2 (Ducon 12147067)		
		
Pin#	Conductor	Wire Color
A	W199	BLK
B	W167	RED

X6 (Delphi 12052613)

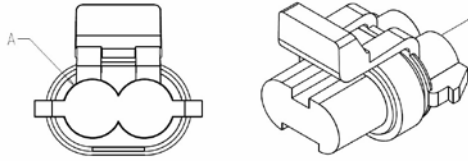

Pin#	Conductor	Wire Color
A	W191	WHT
B	W194	BLK

X7 (Delphi 12015792)

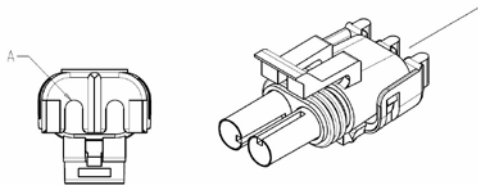

Pin#	Conductor	Wire Color
A	W284	BRN
B	W283	VIO/BLK

X126 (AMP 282087-1)

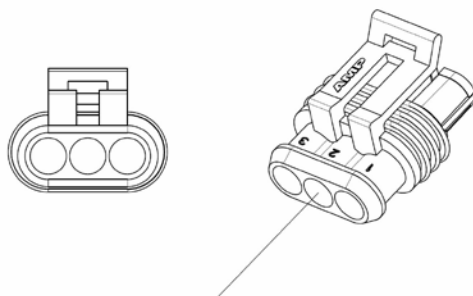

Pin#	Conductor	Wire Color
1	W172	BRN
2	W173	RED-VIO
3	W174	YEL-ORN

X127 (Delphi 15363990)

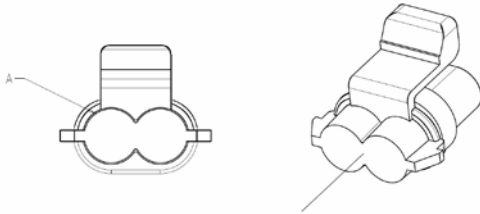

Pin#	Conductor	Wire Color
A	W170	RED
B	W171	BLK

X139 (Delphi 12020786)

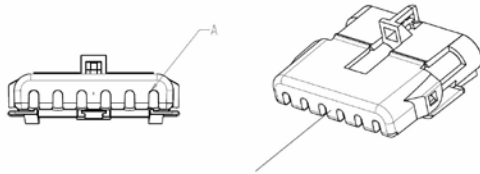

Pin#	Conductor	Wire Color
A	W055	ORN/BLK
B	W054	BLU
C	W204	RED/VIO
D	W165	YEL/BLK
E	–	–
F	W218	BLK/WHT

X143 (Ducon 12147067)

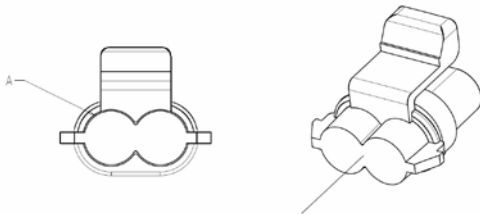

Pin#	Conductor	Wire Color
A	W273	RED/GRN
B	W274	YEL/BLK

X144 (Delphi 12015792)

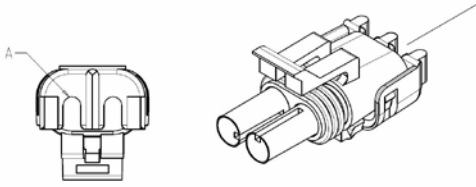

Pin#	Conductor	Wire Color
A	W278	ORN
B	W275	RED/WHT

X161 (Delphi 12020926)

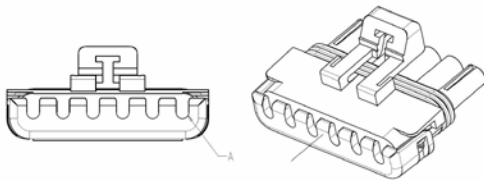

Pin#	Conductor	Wire Color
A	W272	GRA
B	W271	YEL
C	W289	WHT/BRN
D	W293	BRN
E	W294	BRN

Recovery System

Functional Description

The Recovery System pulls the wastewater from the squeegee and directs it into the recovery tank. The 24-volt, three-stage electric vacuum motor creates a vacuum in the recovery tank with sufficient airflow to lift the used cleaning solution from the squeegee and into the vacuum hose assembly, which then directs the water into the recovery tank.

The Operator can select from two vacuum power levels – standard and quiet vacuum.

The Recovery System includes the **Vacuum Hose Assembly, Debris Cage, Recovery Tank, Vacuum Motor, Solid State Relay, Float Cage Assembly** and **Drain Hose**.

- The **Vacuum Hose Assembly** attaches to the squeegee assembly and directs the wastewater from the squeegee to the **Debris Cage** and **Recovery Tank**.
- The **Vacuum Motor** creates a vacuum inside of the **Recovery Tank** to pull the wastewater from the squeegee into the **Recovery Tank**.
- The **Float Cage Assembly** contains two internal plastic float balls that will rise to shut off the air intake to the **Vacuum Motor** if the wastewater level in the **Recovery Tank** gets too high. This is to prevent water from getting into the **Vacuum Motor** and possibly damaging the **Vacuum Motor**.
- The **Debris Cage** inside the **Recovery Tank** catches any large debris or particulates to keep these materials out of the **Recovery Tank**. The debris tray cover can be removed to clean out the **Debris Cage**.
- The **Recovery Tank** holds the wastewater picked up by the squeegee. Note that the **Recovery Tank** is hinged at the rear and tips back for access to the **Vacuum Motor**. The **Drain Hose** is used to drain the wastewater from the **Recovery Tank**.

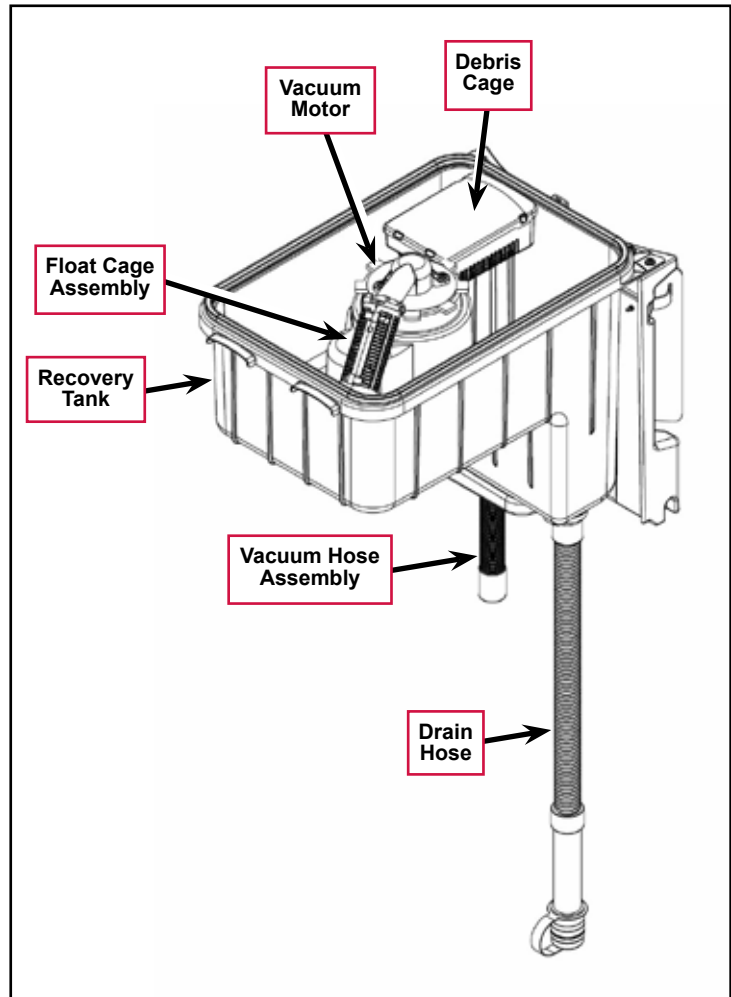

Vacuum Motor On

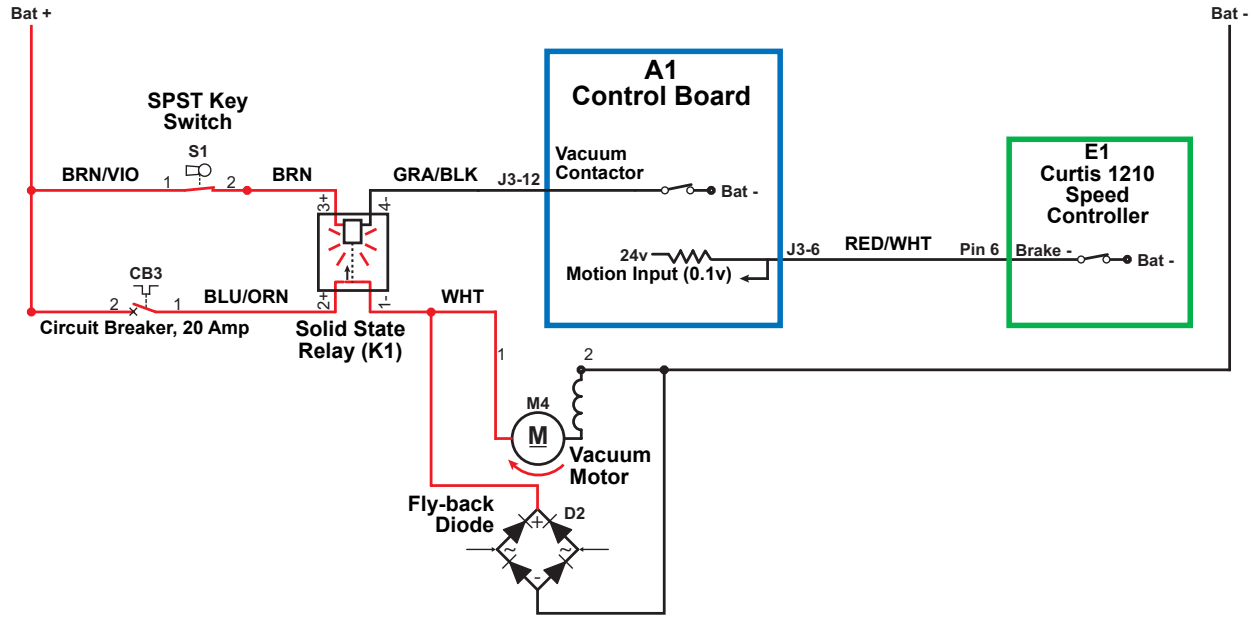

The following conditions must be met before the **Vacuum Motor** can start:

- There can be no major faults active.
- The machine must not be in a low-voltage condition.
- The Scrub System or vacuum mode must be activated (the Vacuum Mode Indicator will be on or flashing).
- The **A1 Control Board** must have recently detected a motion signal from the **E1 Curtis Speed Controller**. (The **A1 Control Board** will switch off the **Vacuum Motor** after a maximum 10 second delay once it loses the drive signal from the **E1 Curtis Speed Controller**.)

When the Operator selects a drive direction and presses the go pedal:

- The **Brake -** switch on **Pin 6** in the **E1 Curtis Speed Controller** closes to ground. This drops the voltage on the **Motion Input** line on pin **J3-6** from 24v down to nearly 0 volts to signal the **A1 Control Board** that the machine is now in motion.
- The **A1 Control Board** switches the **Vacuum Contactor** line on pin **J3-12** to battery ground to energize the **Solid State Relay (K1)** and switch on the **Vacuum Motor**.

Note that the output from the **Vacuum Contactor** line on pin **J3-12** drives the **Solid State Relay** at 100 Hz with either a 100% duty cycle for the high/standard vacuum mode, or a modulated (60%) duty cycle to provide an average of 16.8V to the **Vacuum Motor** in the low/quiet vacuum mode.

"Field" Voltage Measurements with Reference to Battery Negative			
Pin Number	Wire Color	Description	Voltage
J3-12	GRA/BLK	Vacuum Contactor	23.4v - Vacuum Off
			6.9v - Vacuum Low/Quiet
			0.104v - Vacuum High/Standard

Component Locations

The following components are included in this section:

- Recovery Tank
- Vacuum Motor
- Debris Cage
- Float Cage Assembly
- Vacuum Hose Assembly
- Drain Hose
- Solid State Relay (K1)
- Fly-back Diode (D2)

The **Recovery Tank** is located underneath the control panel.

The **Vacuum Motor** is mounted below the **Recovery Tank**.

The **Debris Cage** filters any debris out of the wastewater before it can enter the **Recovery Tank**.

The **Vacuum Hose Assembly** carries the wastewater from the squeegee to the **Debris Cage**.

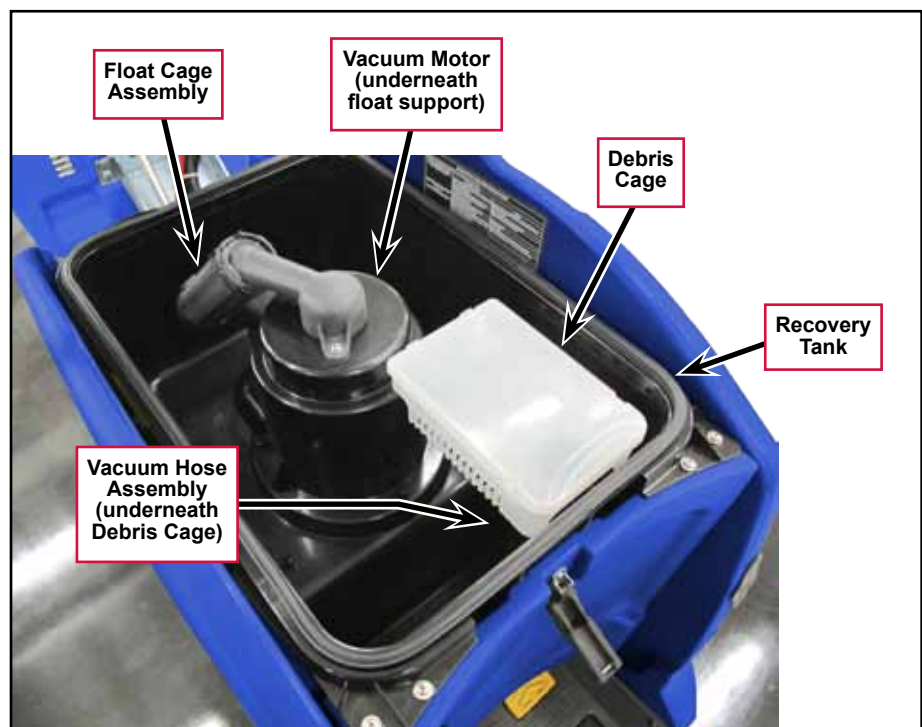

The **Drain Hose** allows you to drain the wastewater from the Recovery Tank.



The **Solid State Relay (K1)** and **Fly-back Diode (D2)** (rectifier bridge) are located inside the control panel assembly

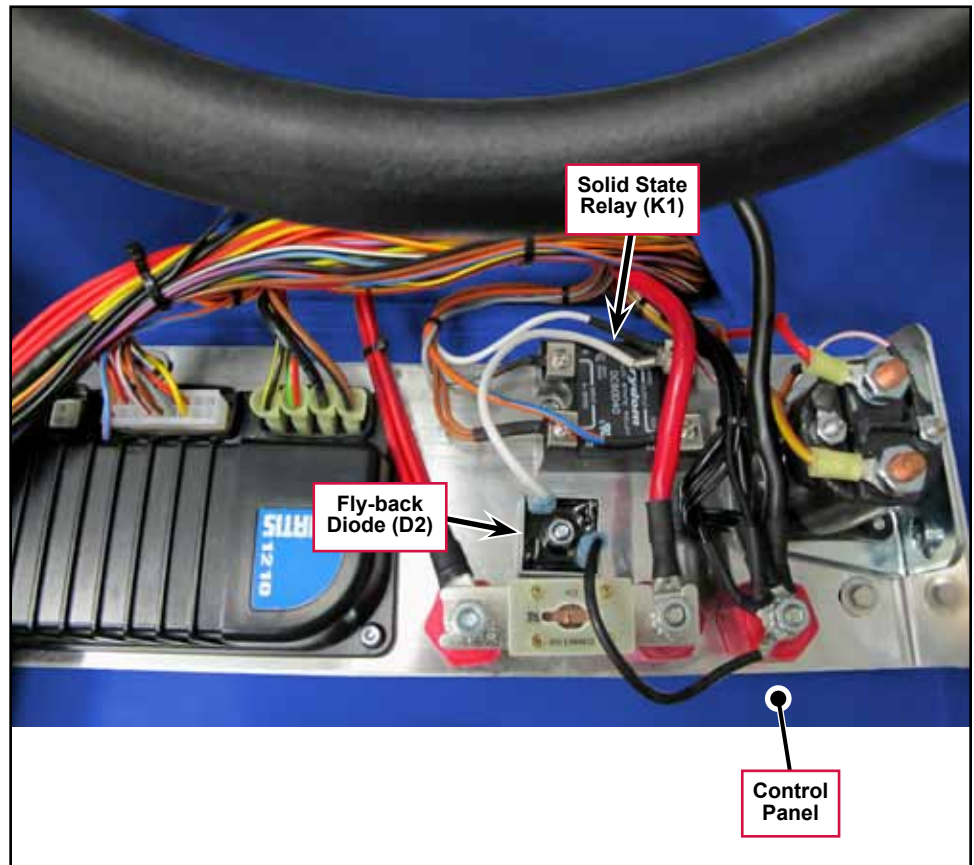

Troubleshooting

General Troubleshooting

Problem	Cause	Correction
Vacuum motor not running - the LED on relay SSR1 is not on.	No voltage from the Key Switch S1 to terminal 3+ on relay SSR1.	Check the wiring from the Key Switch S1 to terminal 3+ on relay SSR1 and repair as necessary.
	Terminal 4- on relay SSR1 is not getting ground from the Vacuum Contactor, pin J3-12, on the A1 Control Board.	Check the wiring from pin J3-12 on the A1 Control Board to terminal 4- on relay SSR1 and repair as necessary.
	Relay SSR1 is faulty.	Replace relay SSR1.
Vacuum motor not running - the LED on relay SSR1 is on.	No voltage to terminal 2+ on relay SSR1.	<ol style="list-style-type: none"> 1. Check circuit breaker CB3 and reset if necessary. 2. Check the wiring from the Key Switch S1 to circuit breaker CB3 and repair as necessary.
	No voltage from terminal 1- on relay SSR1 to the Vacuum Motor M4.	Check the wiring from SSR1 to the Vacuum Motor M4 and repair as necessary.
	The Vacuum Motor M4 is not connected to battery ground.	Check the ground connection to the Vacuum Motor M4 and repair as necessary.
	Relay SSR1 is faulty.	Replace relay SSR1.
Poor water pickup.	Vacuum leak(s) due to: <ul style="list-style-type: none"> • Leaky vacuum hose. • Bad recovery tank gasket. • Drain plug not installed correctly. • Damaged tank. 	<ul style="list-style-type: none"> • Check the squeegee vacuum hose assembly and tighten/replace as necessary. • Check the recovery tank gasket and replace as necessary. • Make sure drain hose plug is installed correctly. • Check the recovery tank for damage.
	Restrictions due to built-up debris in the squeegee tool or vacuum hose.	<ul style="list-style-type: none"> • Check the squeegee tool and vacuum hose assembly for any accumulated dirt or debris and clean as necessary. • Check the vacuum system airflow pathway wherever the airflow is forced to make a sharp turn for any accumulated dirt or debris and clean as necessary.
	Squeegee blades worn or out of adjustment.	<ul style="list-style-type: none"> • Check and replace the squeegee blades if necessary. • Readjust the squeegee as necessary. (Refer to the Squeegee Maintenance and Squeegee Adjustments sections in the Instructions For Use).

Bench-testing the Flyback Diode (bridge rectifier)

When functioning properly, the flyback diode should conduct only when the voltage gets reversed by the vacuum motor. To test the bridge rectifier, use a DC continuity tester or an ohm meter (on the R x 100 scale) as follows. If any of the internal diodes are shown to be defective in any of the following steps the rectifier must be replaced. (Refer to steps 8 and 9 for the correct mounting position and wire connections.)

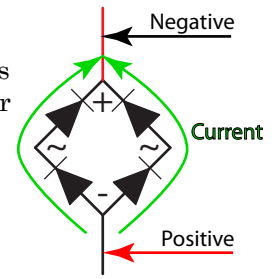

Note that the positive tab on the Flyback Diode is rotated 90 degrees from the other three tabs.

1. Disconnect the two wires from the Flyback Diode.

Reverse Bias Test

In the reverse bias direction, none of the internal diodes should conduct.

2. Connect the negative test lead to the negative terminal on the rectifier.
3. One at a time, touch the positive test lead to the remaining 3 terminals.
 - If the meter beeps or reads continuity for any of the 3, then the rectifier is defective.
 - If the meter does not beep, continue with the next step.

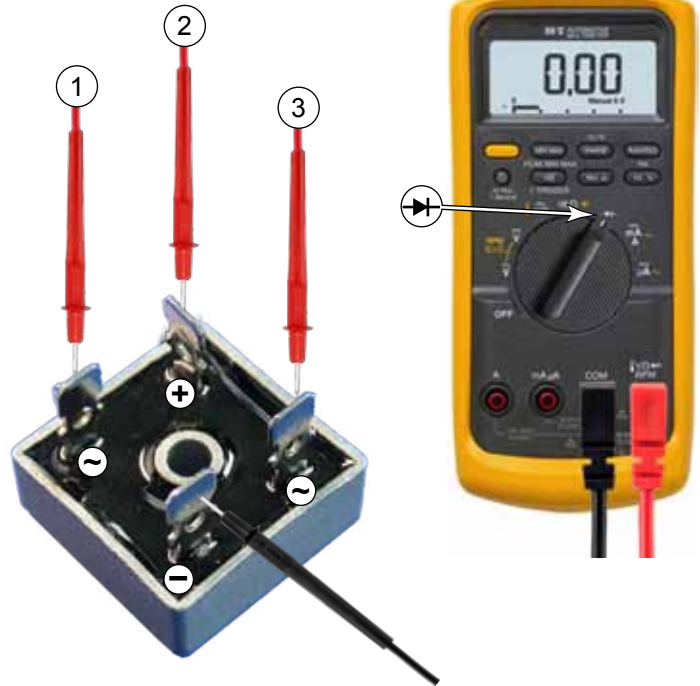

Forward Bias Test

In the forward bias direction, all of the diodes should conduct. Due to parallel paths, the positive and negative terminals have to be checked separately.

4. Connect the negative test lead to the positive terminal on the rectifier.
5. One at a time, touch the positive test lead to the 2 AC terminals (1&2).
6. Connect the positive test lead to the negative terminal on the rectifier.
7. One at a time, touch the negative test leads to the 2 AC terminals (3&4).

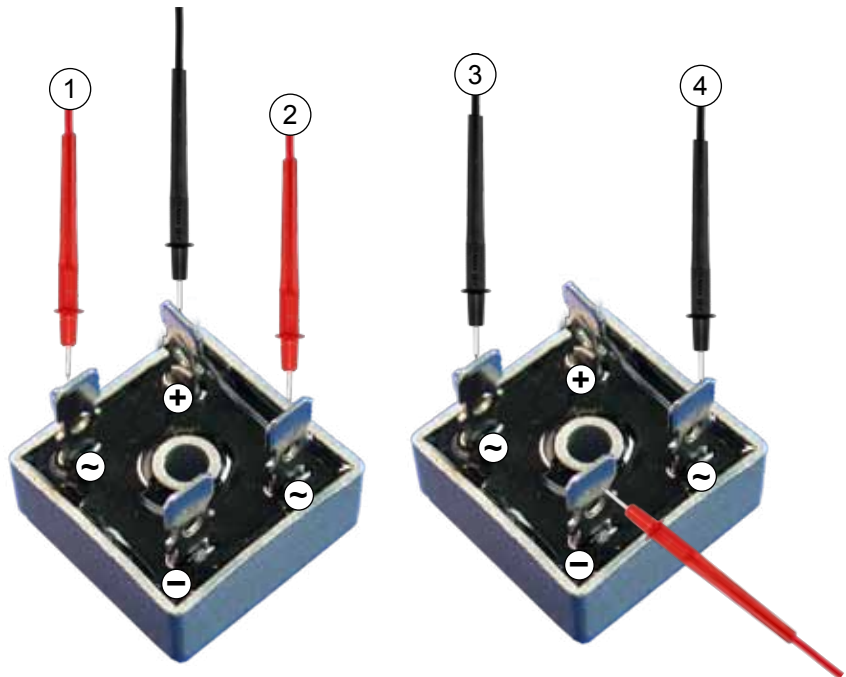

- If the meter does not beep or reads open circuit for any of the 4, then the rectifier is defective.
- If the meter beeps for all 4, then the rectifier is good.

- 8. If you replace the **Fly-back Diode**, make sure the **Positive Tab** is in the upper left position as shown, then fasten the **Fly-back Diode** to the electrical panel with the **Screw** and **Nut**.
- 9. Connect the **White Wire** to the **Positive Tab** and the **Black Wire** to the opposite tab as shown.

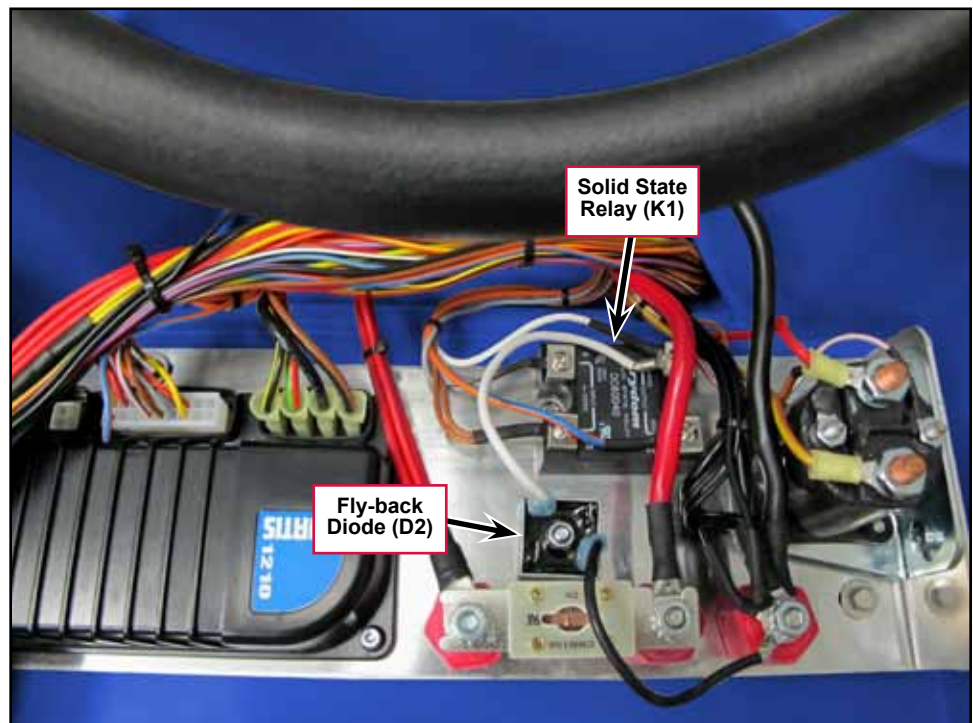
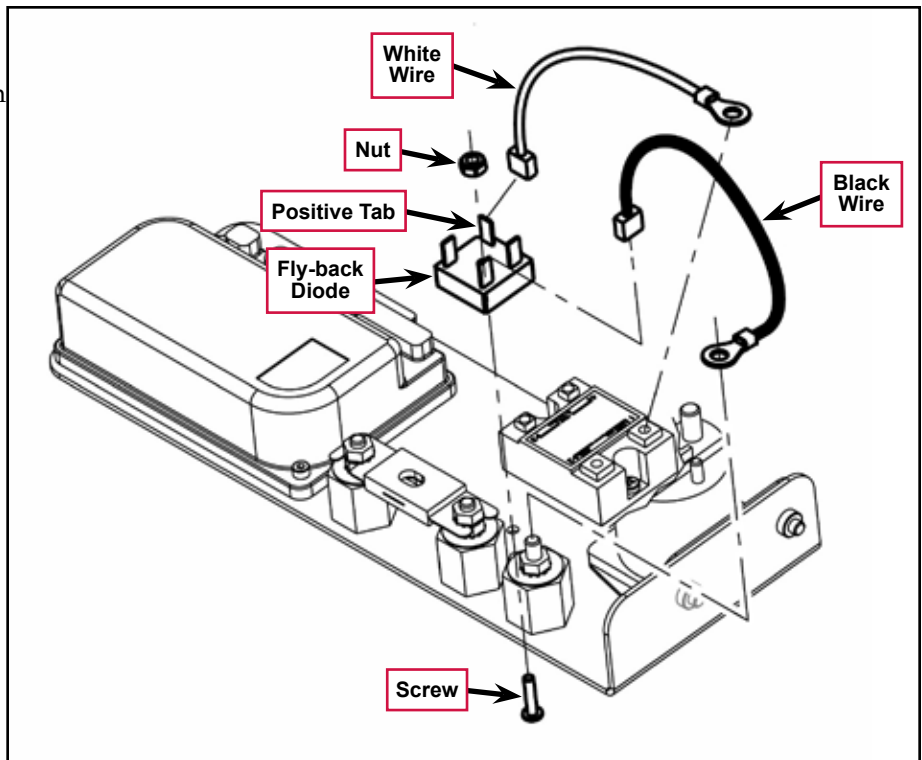

Removal and Installation

Vacuum Motor

1. Drain the recovery tank.
2. Lift the recovery tank to access the **Vacuum Cover**.
3. Remove the three **M6 Screws, Flat Washers** and **Cover Plates** and remove the **Vacuum Cover** to access the vacuum motor.



Caution: Do not over torque the mounting screws on reassembly. Torque the three screws to 3 NM (26 in lb)

4. Disconnect the **Vacuum Motor Electrical Connector**.
5. Remove the **Vacuum Motor** from the **Recovery Tank**.
6. Reinstall the **Vacuum Motor** by following the above steps in reverse order.



Note: Make sure you install the **Acoustic Insulation** correctly around the **Vacuum Motor** when you reinstall the **Vacuum Motor**.



Note: Before you reinstall the **Vacuum Cover**, make sure the top of the **Vacuum Motor** is centered in the matching cutout in the **Recovery Tank** as shown.

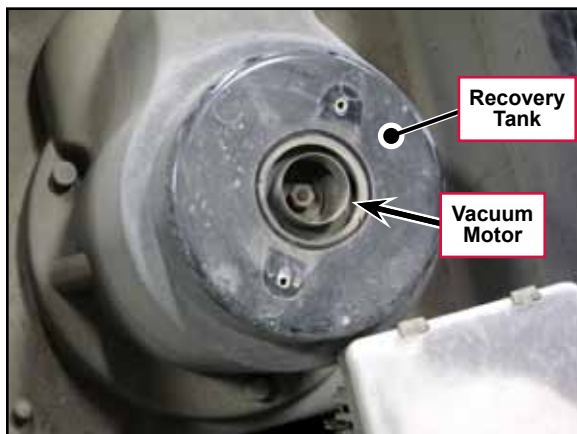
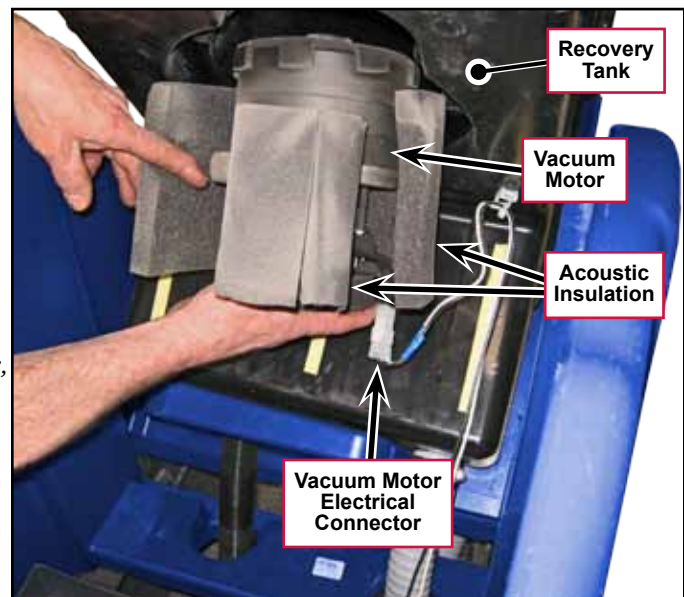

Specifications

Component	Specifications	
Vacuum Motor	Current Draw	Low Speed: 11 - 12 Amps
		High Speed: 16 - 17 Amps
Vacuum Water Lift	Sealed	40 - 44 Inches of Water
	1" open hole	9.5 Inches of Water
Vacuum Motor Mounting Screws	3 NM (26 in lb)	

Special Tools

<p>Vacuum water lift gauge, p/n 56205281</p>	
--	--

Scrub System

Functional Description

The Scrub System includes the Scrub Deck, Brush or Pad Motor, Brush Motor Contactor (K2 relay) and Deck Actuator Assembly. A 24-volt electric motor powers the brush/pad.

The scrub deck has four vertical positions:

- The scrub deck is in the fully-retracted (up) position when the machine is in the transport mode (no scrubbing or vacuuming).
- The vacuum-only position lowers the scrub deck so the attached squeegee contacts the floor, but the brush/pad is raised slightly above the floor. This position is used for wet vacuuming of wastewater from the floor with no scrubbing.
- The “normal” scrub pressure position lowers the scrub deck so the brush/pad contacts the floor with normal scrub pressure.
- The “extra” scrub pressure position lowers the scrub deck to its extension limit so the brush/pad contacts the floor with greater than normal scrub pressure.

The **20D Scrub Decks** have a 20” brush plate assembly to accommodate a variety of disc brushes. The 20D models can also be used with several grades of pads by using the optional pad holder. The brush is driven by a Brush Motor connected to a 90-degree Gearbox.

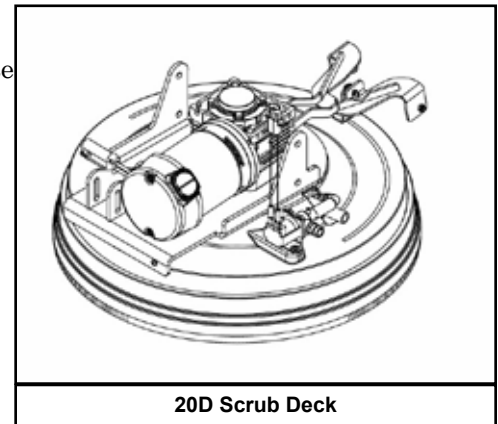

Scrub Deck and Motor

20D Scrub Deck

The 20D Scrub Decks use a horizontally-mounted **Brush Motor** with an integral gearbox to drive the **Brush Plate Assembly** and attached **Brush**. The **Brush Motor** is fastened to the **Motor Spacer**, which is bolted to the **Deck Lift Plate Weldment**, **Brush Housing** and **Lower Deck Plate**.

The **Solution Solenoid Valve Assembly** controls the solution flow to the **Brush**.

The squeegee assembly snaps onto the **Squeegee Link Weldment**.

The **Brush Skirt** helps contain the cleaning solution.

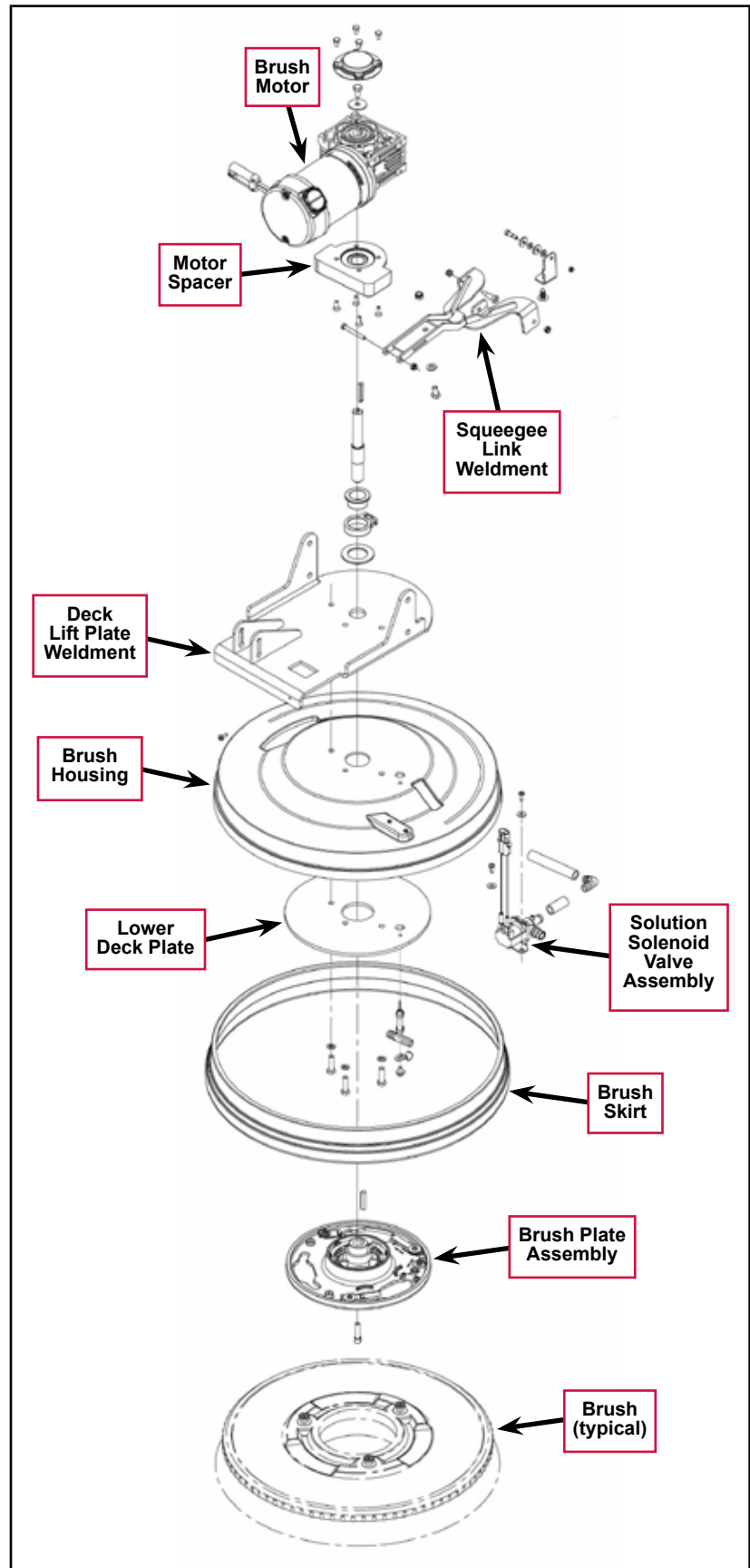

Brush Motor Contactor

The **Brush Motor Contactor (K2)** controls the power to the Brush/Pad Motor.



Deck Actuator Assembly

The **Deck Actuator Assembly** uses an electric **Motor** to run a lead screw that extends and retracts the **Tube** and attached **Plunger**. The **Plunger** is connected to the Scrub Deck to raise and lower the Scrub Deck to any of four different positions:

- The fully-retracted (up) position is the Scrub Deck transport position and is used when the Scrub and Recovery Systems are not active.
- Scrub Deck position 1 is the vacuum-only position. In this position the Deck Actuator lowers the Scrub Deck just far enough for the squeegee to contact the floor to pick up wastewater with the Scrub, Solution and Detergent Systems off.
- Scrub Deck position 2 is the standard scrub pressure position.
- The fully-extended (down) position is the extra scrub pressure position.

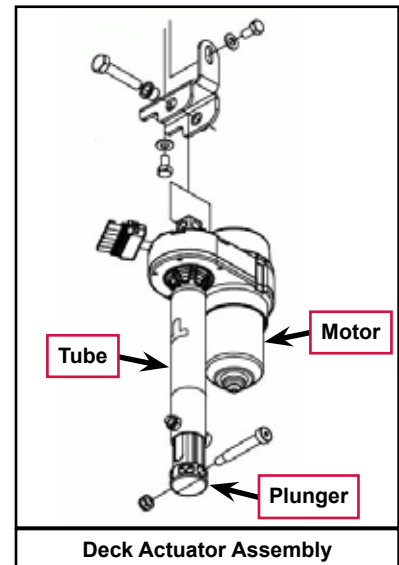

Two internal **Position Switches**, actuated by rotating **Cams**, provide actuator position feedback to the A1 Control Board.

Two internal **Limit Switches** (top and bottom), also actuated by rotating **Cams**, switch off the actuator **Motor** at the fully-retracted and fully-extended positions.

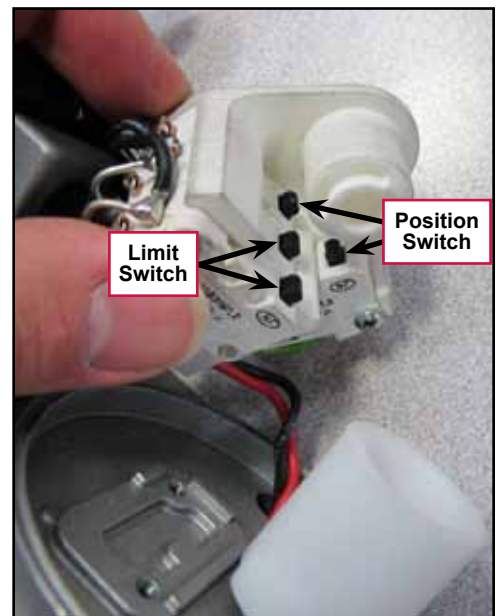
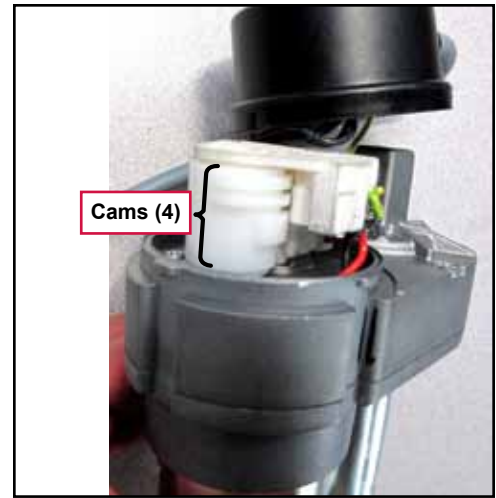

Circuit Descriptions

Scrub Brush Motor

Scrub Brush Motor Off

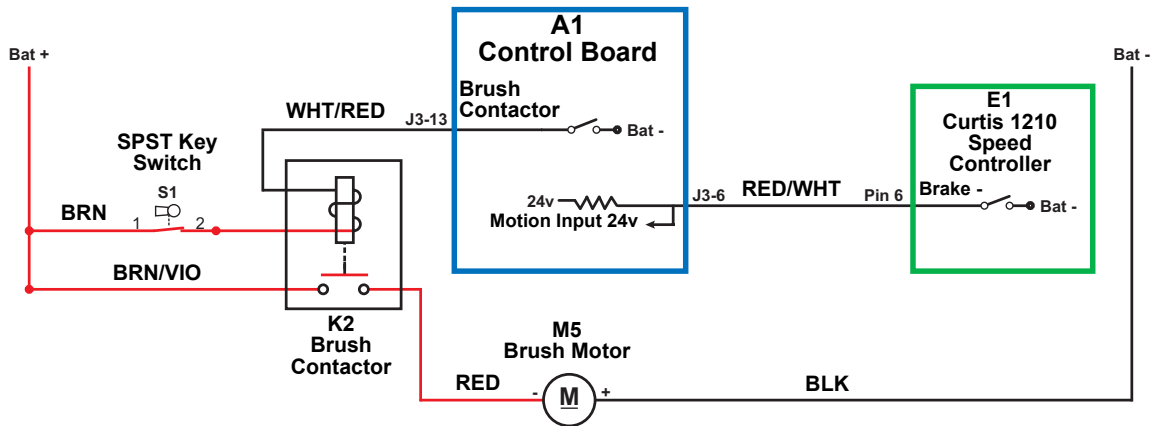

When the machine is stationary:

- The **Brake -** switch on **Pin 6** in the **E1 Curtis Speed Controller** is open and is not sending the drive signal to the **Motion Input** line on pin **J3-6** on the **A1 Control Board**.
- The **Brush Contactor** switch on pin **J3-13** is open, the **K2 Brush Contactor** is de-energized and open, and the **M5 Brush Motor** is off.

Scrub Brush Motor On

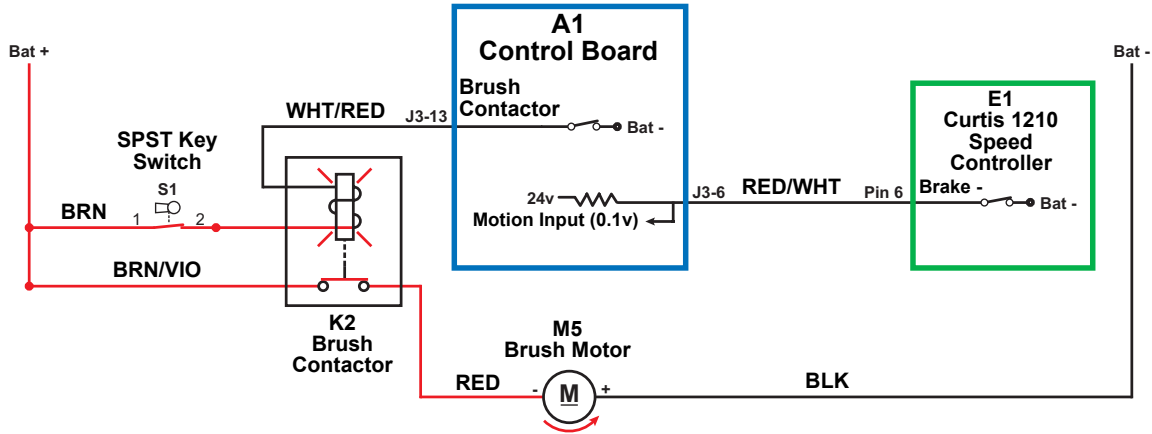

The following conditions must be met before the **Brush Motor** can start:

- There can be no major faults active.
- The machine must not be in a low-voltage condition.
- The Scrub System must be enabled (the Solution On/Off Indicator is lighted).
- The **S7 POS 1** limit switch on the scrub deck actuator must be closed to indicate that the scrub deck is below the vacuum-only position.
- The **A1 Control Board** must receive a motion signal from the **E1 Curtis Speed Controller**.

When the Operator selects a drive direction and presses the go pedal:

- The **Brake -** switch on **Pin 6** in the **E1 Curtis Speed Controller** closes to ground. This drops the voltage on the **Motion Input** line on pin **J3-6** from 24v down to nearly 0 volts to signal the **A1 Control Board** that the machine is now in motion.
- The **A1 Control Board** switches the **Brush Contactor** line on pin **J3-13** to battery ground to energize the coil side of the **K2 Brush Contactor** to close the contacts and switch on the **Brush Motor**.

"Field" Voltage Measurements with Reference to Battery Negative			
Pin Number	Wire Color	Description	Voltage
J3-13	WHT/RED	Brush Contactor	24.3v - Brush Motor Off
			0.2v Brush Motor On

Component Locations

The following components are included in this section:

- Scrub Deck
- Scrub Deck Motor
- Brush Motor Contactor (K2)
- Scrub Deck Actuator Assembly

The **Scrub Deck** is suspended underneath the machine and pivots up and down on a mechanical mount.



The **Scrub Deck Motor** is mounted on the top of the **Scrub Deck**. Note that the 20D Scrub Deck and Brush Motor are shown here.

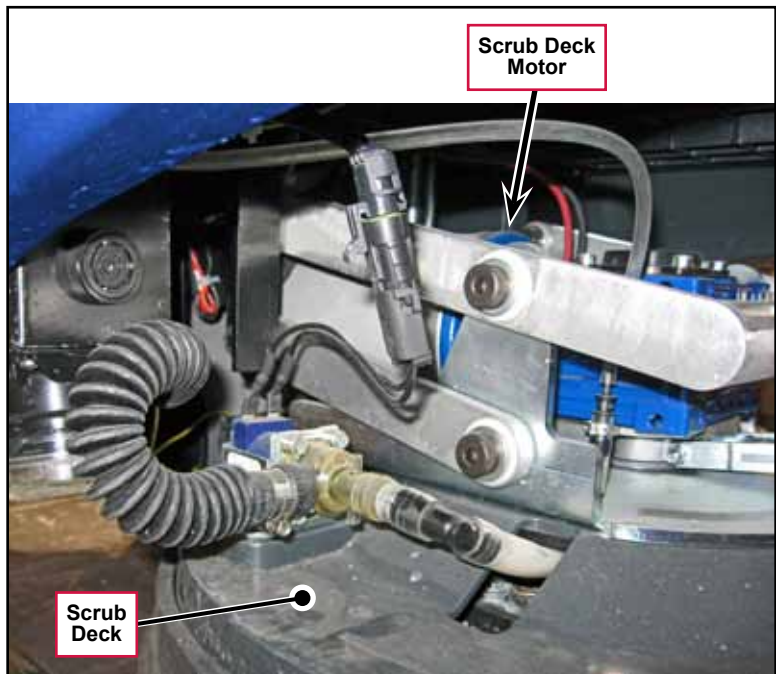

The **Brush Motor Contactor (K2)** controls the power to the scrub deck motor and is located inside the control panel assembly.

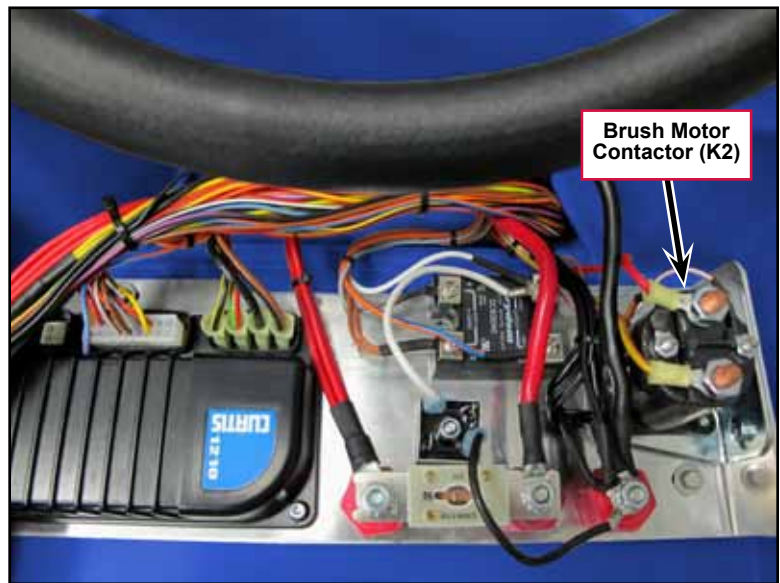

The **Scrub Deck Actuator Assembly** is attached to the **Scrub Deck** and machine frame and lowers and raises the **Scrub Deck**.

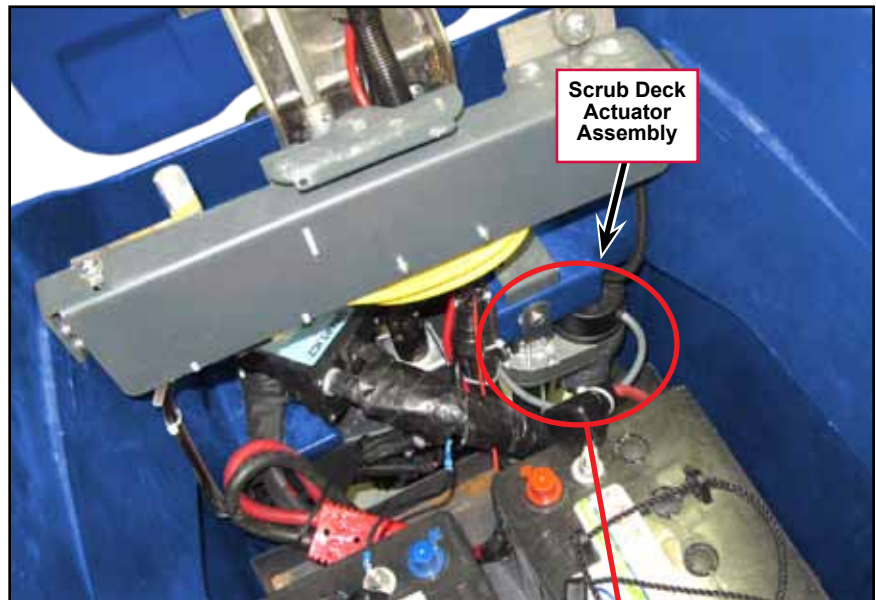

Troubleshooting

Problem	Cause	Correction
Brush Motor not running	No voltage to the K2 Brush Contactor coil	<ol style="list-style-type: none"> 1. Check the voltage on pin J3-13 on the A1 Control Board. The signal, referenced to ground, should be 24.3v with the Brush Motor off, 0.2v with the Brush Motor on. 2. Check the wiring from the Key Switch to the K2 Brush Contactor coil and repair as necessary.
	No voltage through the contacts on the K2 Brush Contactor	<ol style="list-style-type: none"> 1. Check circuit breaker CB4 and reset if necessary. 2. Check the coil resistance on the K2 Brush Contactor. If the coil resistance is not 58.3 ohms $\pm 10\%$, replace K2. 3. Check the continuity through the contacts on the K2 Brush Contactor with the coil energized. If the circuit is open, replace K2. 4. Check the wiring from battery positive to circuit breaker CB4, and from CB4 to the K2 Brush Contactor and repair as necessary. 5. Check the wiring from the K2 Brush Contactor to the Brush Motor and repair as necessary. 6. Check the Brush Motor ground connection and repair as necessary.
Scrub Deck Actuator not running.	No voltage to the Deck Actuator Motor	<p>Check the voltage on pins J1-9 and J1-10 on the A1 Control Board. The signals, referenced to ground, should be as follows:</p> <p>Pin J1-9:</p> <ul style="list-style-type: none"> • 2.1v or 3.8v – actuator at rest • 0.2v – actuator extending • 22.9v – actuator retracting <p>Pin J1-10:</p> <ul style="list-style-type: none"> • 2.1v or 3.8v – actuator at rest • 22.9v – actuator extending • 0.2v – actuator retracting
Scrub Deck not being lowered to the vacuum-only position	No signal from Position Switch 1, S7, to pin J2-12 on the A1 Control Board.	Check the voltage on pin J2-12 on the A1 Control Board. The signals, referenced to ground, should be 4.99v with the switch open and 0.03v with the switch closed.
Scrub Deck not being lowered to the normal scrub position.	No signal from Position Switch 2, S6, to pin J2-11 on the A1 Control Board.	Check the voltage on pins J2-11 on the A1 Control Board. The signals, referenced to ground, should be 4.99v with the switch open and 0.03v with the switch closed.

Removal and Installation

Scrub Deck

1. Turn the key switch on, then press the Scrub On/Off Switch to lower the scrub deck to the normal scrub position. This will relieve the tension between the scrub deck actuator and the scrub deck.
2. With the scrub deck down and the key switch on, disconnect the **Actuator Electrical Connector**. Note that you may need to cut a wire tie to do this.
3. Turn the key switch off.
4. Make sure the **Ball Valve** from the solution tank to the **Filter** is set to the off position.

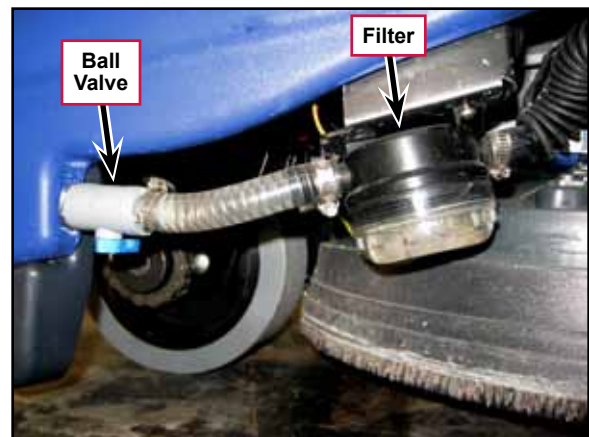
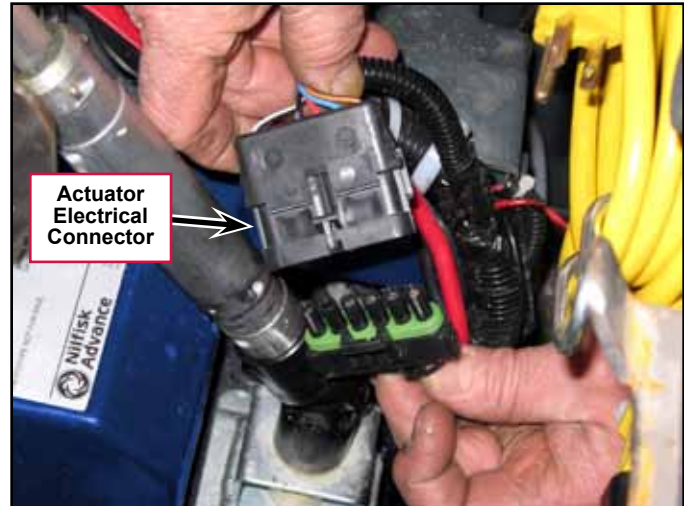

5. Loosen the **Clamp** and remove the **Solution Hose** from the **Solution Solenoid Valve**. Note that a small amount of solution may leak out from the **Solution Hose** when you disconnect it from the **Solution Solenoid Valve**.
6. Disconnect the **Solenoid Electrical Connector**.
7. Disconnect the **Detergent Hose** from the **Scrub Deck**.

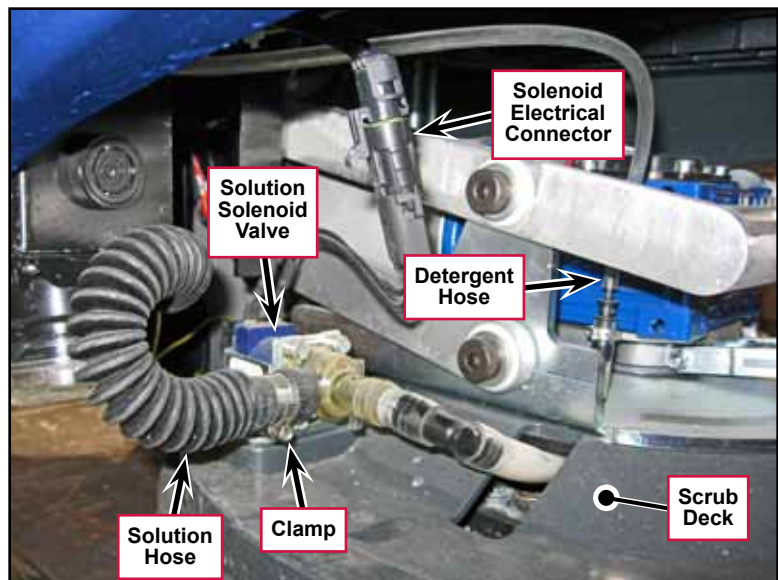

8. Remove the **Vacuum Hose** from the **Scrub Deck**.
9. Press the rear of the **Squeegee Mount Bracket** to disengage it from the pins on the **Squeegee Link Weldment** and remove the **Squeegee** from the **Scrub Deck**.

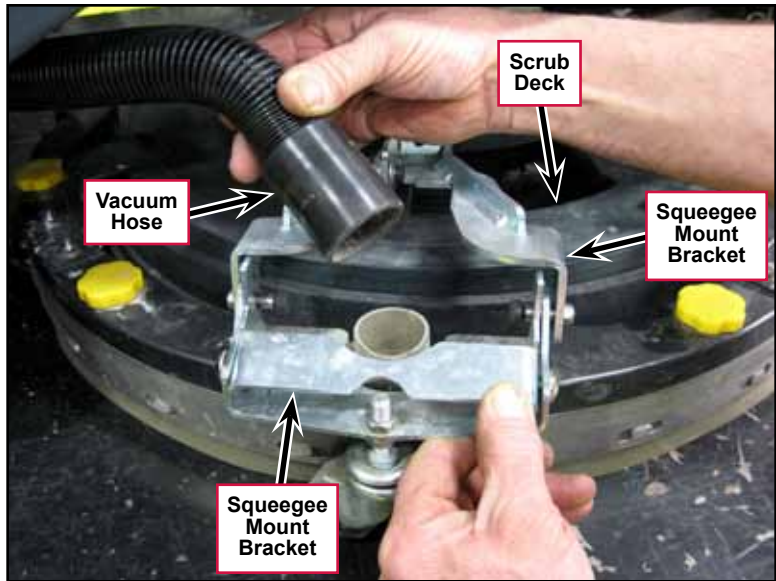

10. Remove the four **Shoulder Screws** holding the **Lift Plate Weldment** to the **Link Bar** and the two **Linkage Bars**. Note that you'll need to hold the M10 Nyloc® nuts with a 17mm wrench while you remove the **Shoulder Screws**.

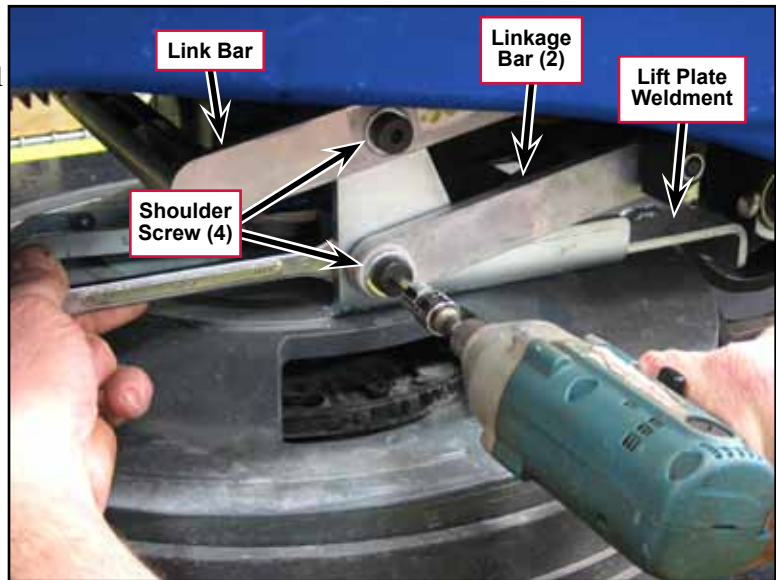

11. Remove the **Shoulder Screw** and nut that connect the scrub deck actuator to the **Lift Plate Weldment** on the scrub deck. Note that you'll need to hold the M8 Nyloc® nut with a 13mm wrench while you remove the **Shoulder Screw**.

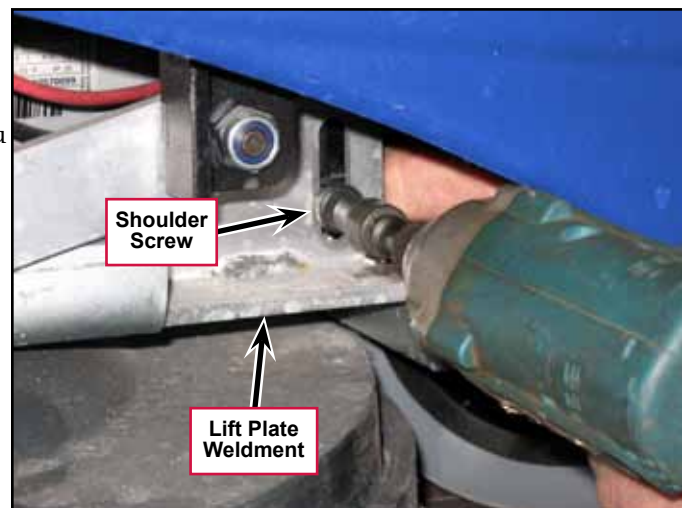



Service Tip: Note of the rotational position of the screw hole in the **Plunger** when you remove the **Shoulder Screw**. Be careful not to rotate the **Tube** and **Plunger** once the **Scrub Deck Actuator** is disconnected from the scrub deck. This can cause the **Scrub Deck Actuator** to get out of adjustment.

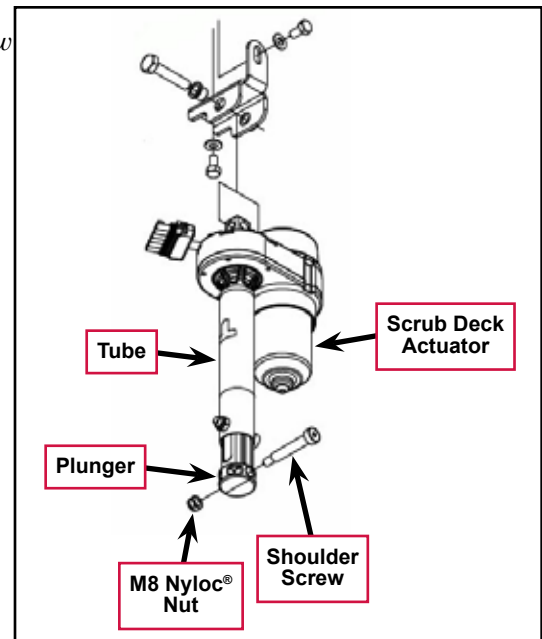

12. Lift up the link bar and rotate the scrub deck slightly (counterclockwise as viewed from the top) to get some slack in the **Scrub Deck Ground Wire**.
13. Disconnect the **Scrub Deck Ground Wire** from the scrub deck.

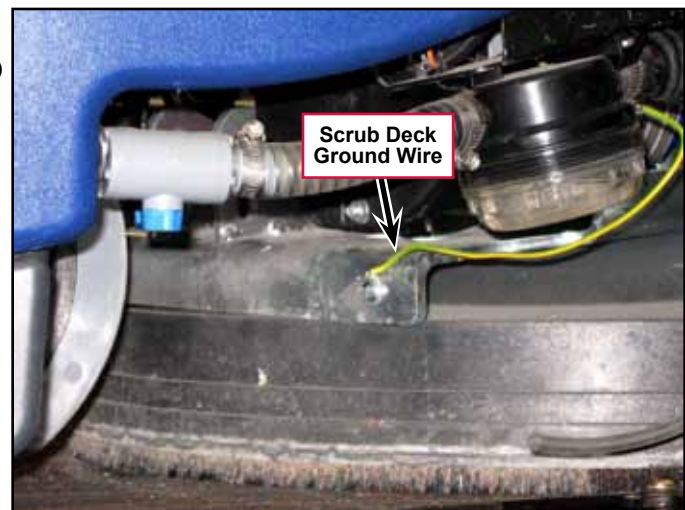

14. Disconnect the **Scrub Deck Motor Electrical Connector**.
15. Carefully slide the deck out of the machine.



Service Tip: The scrub motors on the 20R REV™ scrub decks are slightly taller than the motors on 20D decks. When you remove a 20R REV™ scrub deck you'll need to jack up and block the front of the machine slightly in order to get adequate clearance to remove the deck from the machine.

16. Reinstall the deck by following the above steps in reverse order.

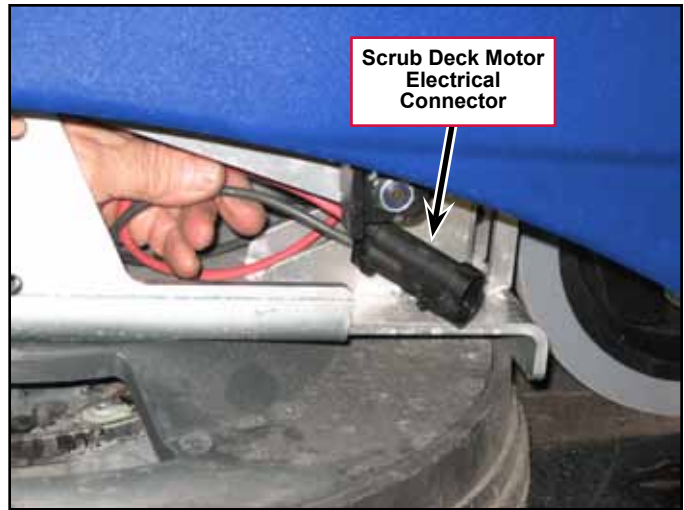

Caution: Note that the scrub deck actuator will automatically raise the scrub deck when you reconnect the **Actuator Electrical Connector**.



Service Tip: When you reinstall the scrub deck, make sure you have all 16 **Link Arm Bushings** and all eight **12mm Flat Washers** installed in the **Link Bar** and **Linkage Bars** before reinstalling the **Shoulder Bolts** and **Nyloc® Nuts**.

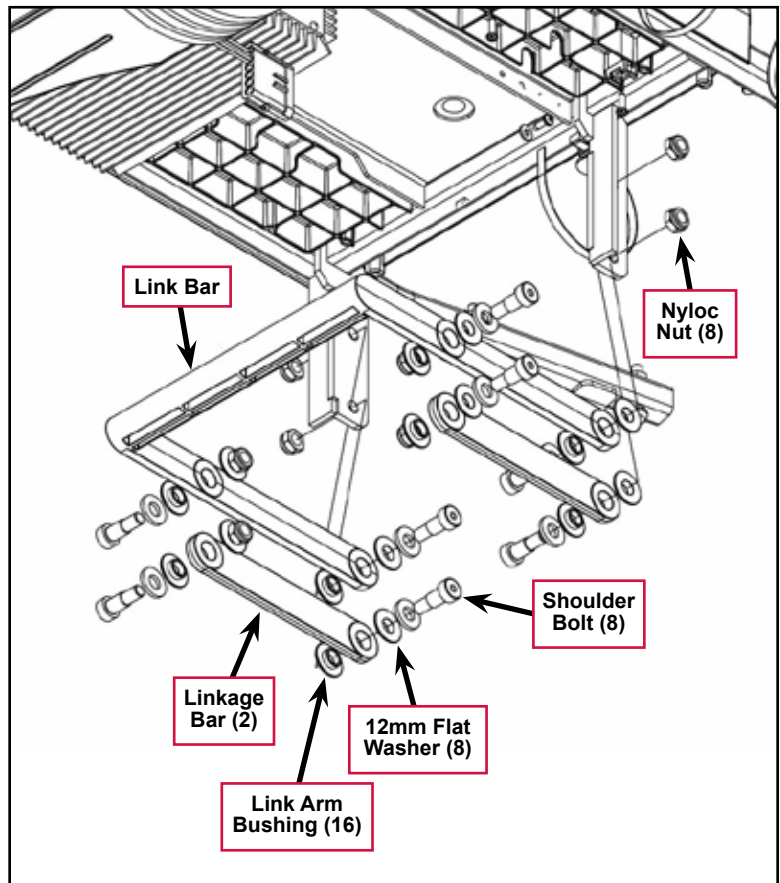

Scrub Deck Actuator Assembly

1. Turn the key switch on, then press the Scrub On/Off Switch to lower the scrub deck to the normal scrub position. This will relieve the tension between the scrub deck actuator and the scrub deck.
2. With the scrub deck down and the key switch on, disconnect the **Actuator Electrical Connector**. Note that you may need to cut a wire tie to do this.
3. Turn the key switch off.
4. Disconnect and remove the battery closest to the scrub deck actuator to get enough clearance to remove the actuator.

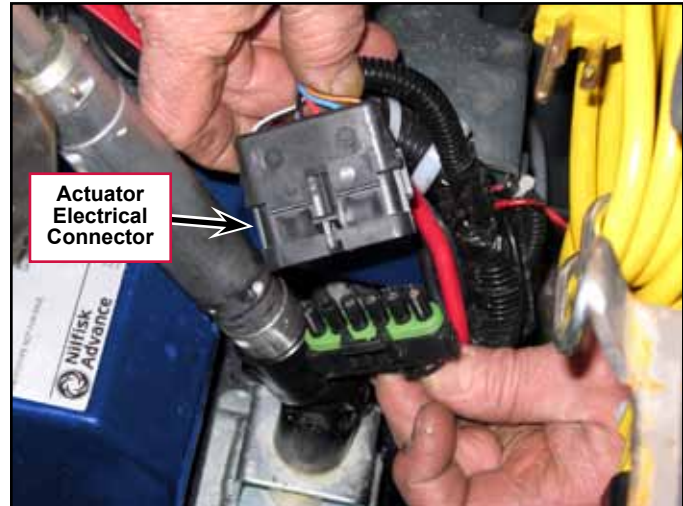

5. Remove the **Shoulder Screw** and nut that connect the scrub deck actuator to the **Lift Plate Weldment** on the scrub deck. Note that you'll need to hold the M8 Nyloc® nut with a 13mm wrench while you remove the **Shoulder Screw**.

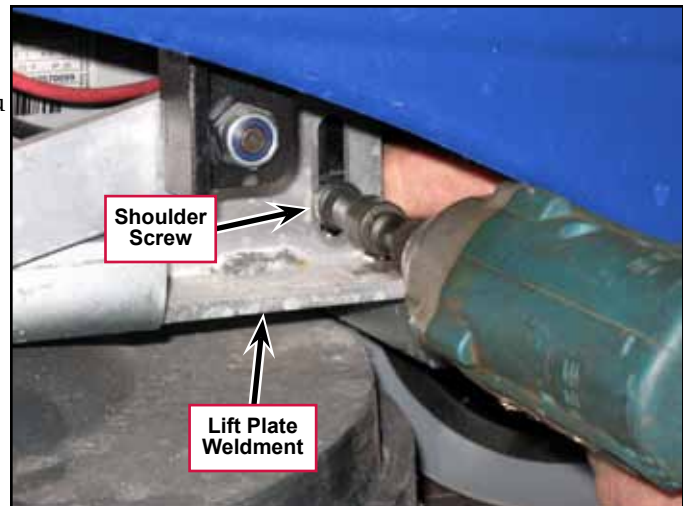

6. Remove the **M10 Screw** and actuator spacer holding the **Scrub Deck Actuator** to the **Actuator Bracket** on the machine frame.
7. Carefully remove the **Scrub Deck Actuator** from the machine.

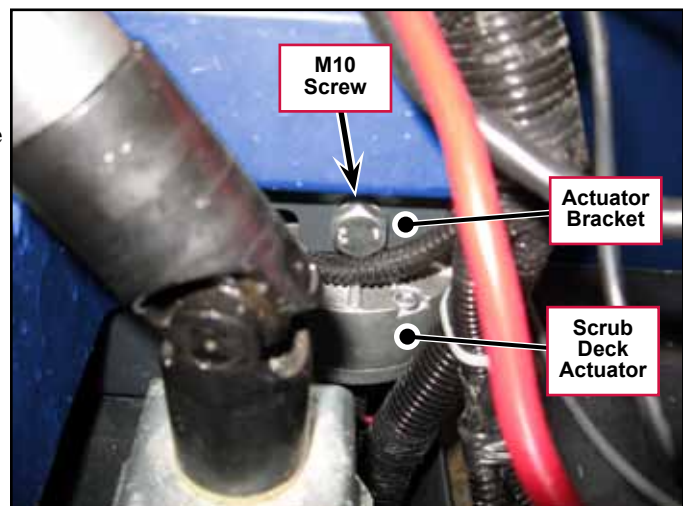



Service Tip: If you're going to reinstall the **Scrub Deck Actuator** without readjusting the position of the **Tube**, be careful not to rotate the **Tube** and **Plunger** with the **Scrub Deck Actuator** out of the machine. This can cause the **Scrub Deck Actuator** to get out of adjustment.

- Reinstall the scrub deck actuator by following the above steps in reverse order.



Note: If you're installing a replacement scrub deck actuator assembly, or if the scrub deck actuator assembly has gotten out of adjustment, you'll need to set the tube position as described in the **Scrub Deck Actuator Adjustment** subsection below.



Caution: Note that the scrub deck actuator will automatically raise the scrub deck when you reconnect the **Actuator Electrical Connector** and battery.

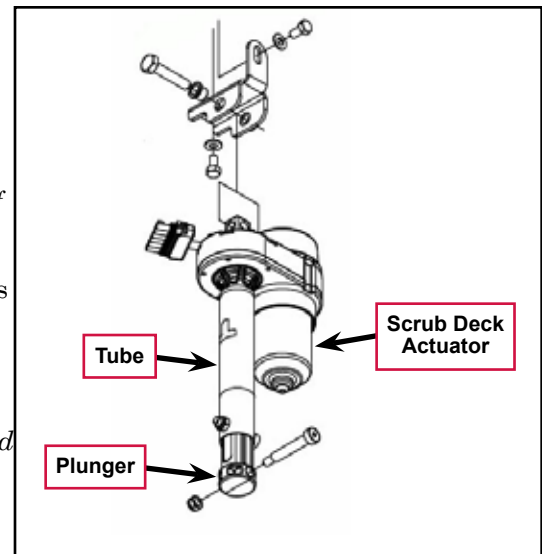

Scrub Deck Actuator Adjustment

The Scrub Deck Actuator adjustment consists of setting the **Tube** position with the retracted travel limit switch actuated. To set the Scrub Deck Actuator position:

- Drive the actuator motor to the up (fully retracted) position using the Service Test Mode or a jumper to the batteries.
- Wait until the motor stops running due to the travel limit switch opening.



Note: Do not allow the **Tube** to bottom out against the **Motor Housing**.

- Manually rotate the **Tube** toward the **Motor Housing** until it bottoms out, then back the **Tube** out at least one-half turn, but no more than one full turn, in order to align the mounting holes.



Service Tip: Be careful not to rotate the **Tube** prior to installing the **Scrub Deck Actuator** into the machine. This can cause the **Scrub Deck Actuator** to get out of adjustment.

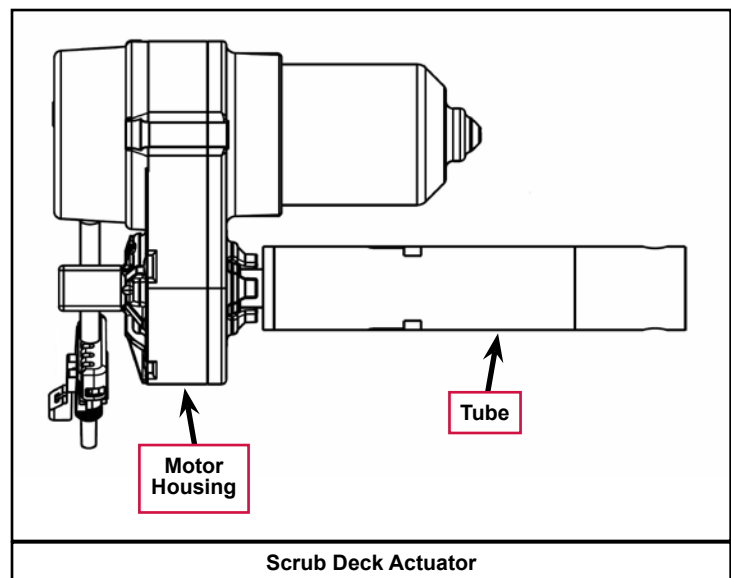

Specifications

Component	Specifications	
20D Scrub Deck Brush Motor	Voltage – 24 VDC	
	RPM – 140	
	Current Draw	No Load ≈ 6.2 Amps
		Normal Operation ≈ 12-19 Amps depending on floor surface, solution flow rate and scrub pressure
	Output Power – 380 Watts / 1/2 HP	
K2 Brush Contactor	Nominal Coil Resistance – 58.3 ohms ±10%	
Scrub Deck Actuator	Voltage – 24 VDC	
	Output Power – 1/6 HP	
	Total Travel – 4.00” ±0.15”	
	Gearbox Ratio – 20.23:1	
	Performance Data	
	No load	Thrust – 0 lbs.
		Speed – 42.5 in/min
		Current Draw – 1.8 ±1.0 Amps max.
	Full load	Thrust – 600 lbs.
		Speed – 34 in/min
		Current Draw – 7.0 ±1.0 Amps
Starting	Thrust – 700 lbs.	

Solution System

Functional Description

The Solution System is a gravity-feed system that supplies cleaning solution to the scrub brush/pad on the scrub deck. The Solution Solenoid Valve controls the solution flow to the scrub deck. The A1 Control Board sends a pulsed voltage signal to the Solution Solenoid Valve that opens and closes the Valve to regulate the solution flow according to the flow rate selected with the solution flow adjustment switch.

The Solution System includes the Solution Tank, Water Filter, Solution Solenoid Valve Assembly and associated valves and hoses.

Solution Tank, Water Filter and Valves

The **Solution Tank** holds approximately 12 gallons [45 liters] of water/solution.

The **Ball Valve** controls the solution flow to the **Water Filter** and downstream **Solution Hose** that is plumbed to the Solution Solenoid Valve.

The **Water Filter** can be disassembled for cleaning.

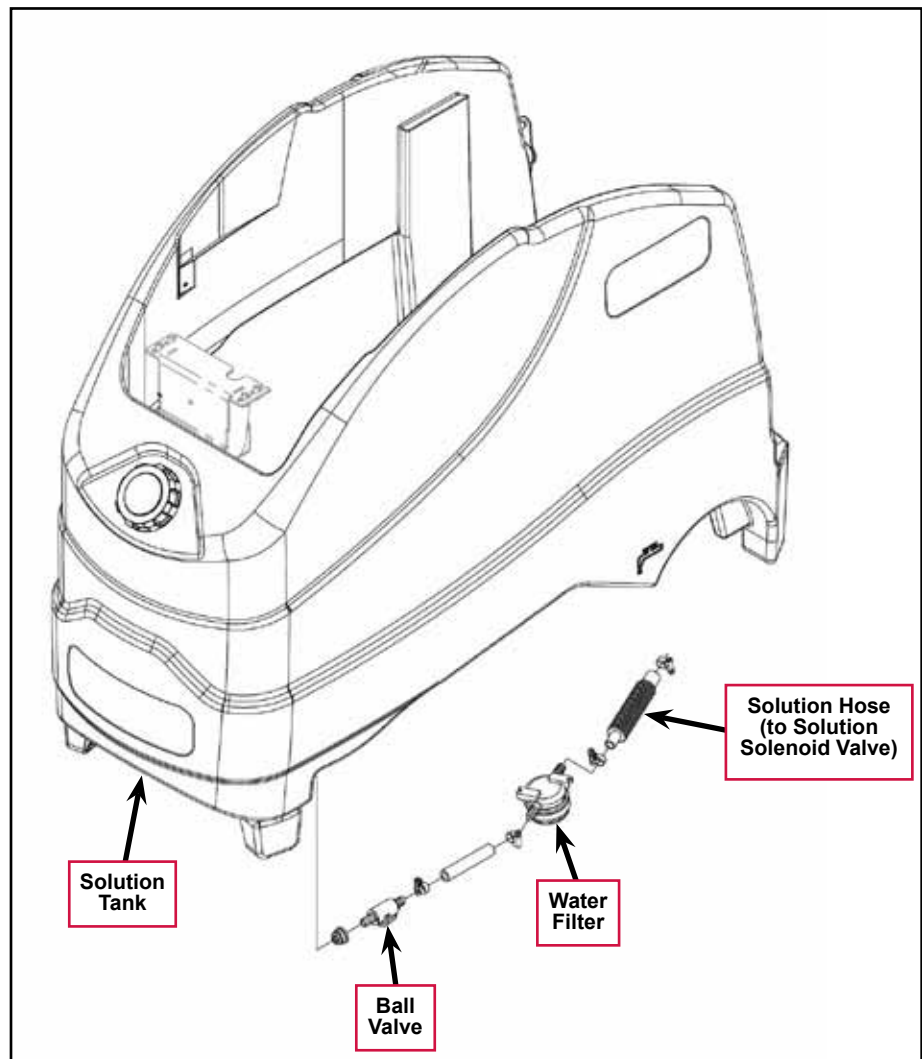

Solution Solenoid Valve

The **L1 Solution Solenoid Valve** controls the solution flow to the scrub deck. The solution from the solution tank enters the **L1 Solution Solenoid Valve** through the side port and exits through the rear port to the scrub deck as shown.

The two wires in the **Electrical Connector** get power from the key switch and pin J3-11 - Solution Solenoid on the A1 Control Board.

The A1 Control Board sends a modulated signal through Pin J3-11 to switch the **L1 Solution Solenoid Valve** to ground and open the **L1 Solution Solenoid Valve** for a period of time corresponding to the selected solution flow rate. The period of time during which the solution solenoid is energized (open) is referred to as the “duty cycle” and is a percentage of the total six-second cycle.

For example, a 50-percent duty cycle would energize and open the **L1 Solution Solenoid Valve** for three seconds during every six-second cycle.



*Note: 100 percent duty cycle is full solution flow with the **L1 Solution Solenoid Valve** continuously open.*

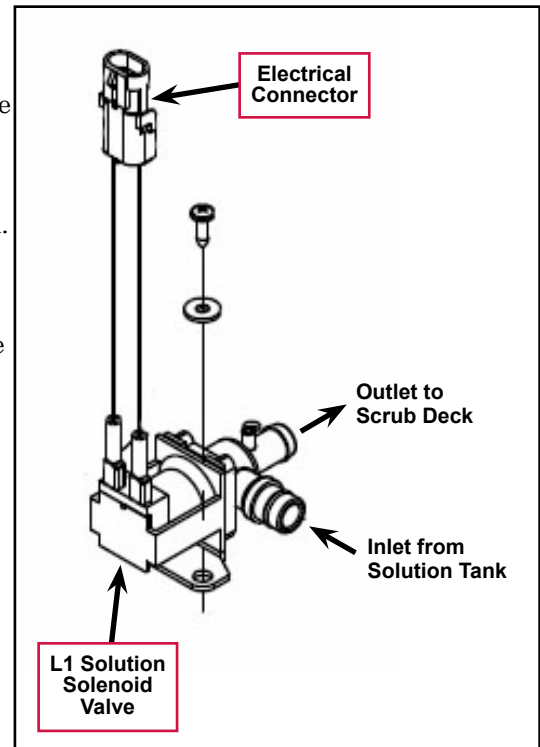

Circuit Descriptions

Solution Solenoid Valve Off

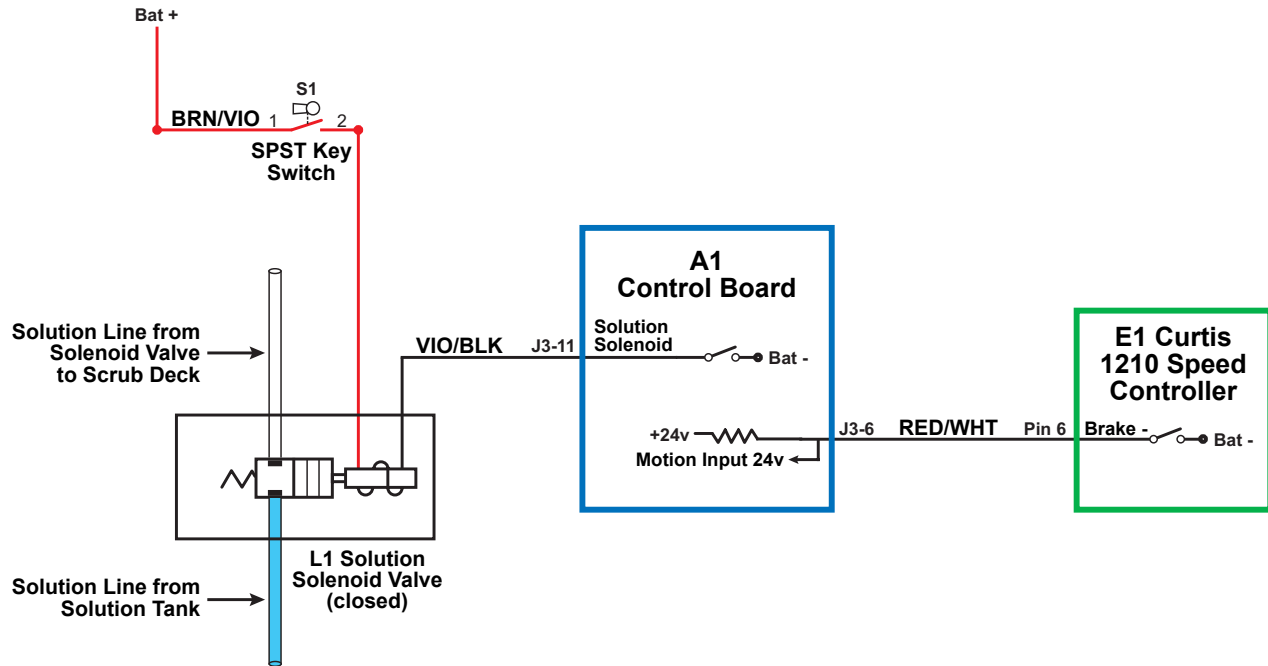

When the machine is stationary:

- The **Brake -** switch on **Pin 6** in the **E1 Curtis Speed Controller** is open and is not sending the drive signal to the **Motion Input** line on pin **J3-6** on the **A1 Control Board**.
- The **Solution Solenoid** switch on pin **J3-11** is open, and the **L1 Solution Solenoid Valve** is de-energized and closed. This prevents solution flow from the solution tank to the scrub deck.

If the Solution System is disabled, the **Solution Solenoid** switch on pin **J3-11** will remain open regardless of whether or not the **A1 Control Board** receives a drive signal from the **E1 Curtis Speed Controller**.

Solution Solenoid Valve On

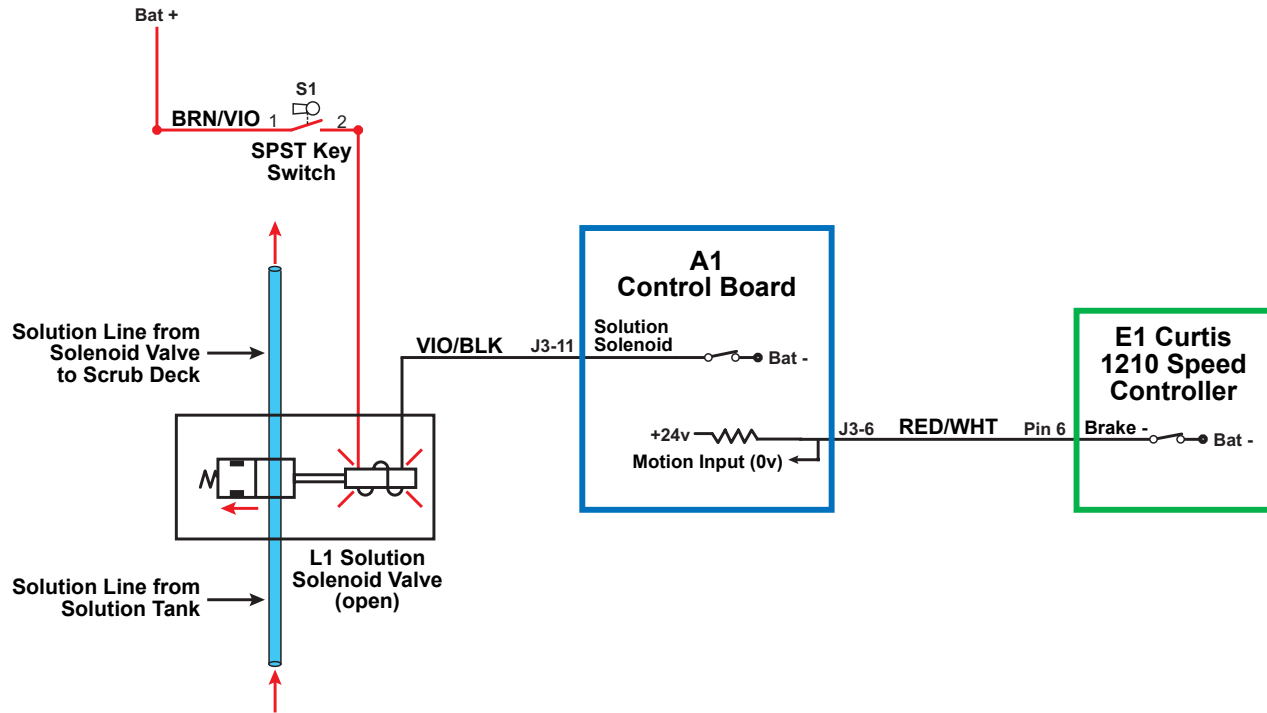

The following conditions must be met before the **L1 Solution Solenoid Valve** can open:

- There can be no major faults active.
- The machine must not be in a low-voltage condition.
- The Scrub System must be enabled (the Solution On/Off Indicator is lighted).
- The **S7 POS 1** limit switch on the scrub deck actuator must be closed to indicate that the scrub deck is below the vacuum-only position.
- The **A1 Control Board** must receive a motion signal from the **E1 Curtis Speed Controller**.

When the Operator selects a drive direction and presses the go pedal:

- The **Brake-** switch on **Pin 6** in the **E1 Curtis Speed Controller** closes to ground. This drops the voltage on the **Motion Input** line on pin **J3-6** from 24v down to nearly 0 volts to signal the **A1 Control Board** that the machine is now in motion.
- The **Solution Solenoid** switch on pin **J3-11** switches to ground to energize and open the **L1 Solution Solenoid Valve**. This allows solution flow from the solution tank to the scrub deck.

Note that the ground signal from the **A1 Control Board** to the **L1 Solution Solenoid Valve** is a pulse-width modulated (PWM) signal. The duty cycle of the PWM signal will vary according to the solution flow rate selected.

"Field" Voltage Measurements with Reference to Battery Negative			
Pin Number	Wire Color	Description	Voltage
J3-11	VIO/BLK	Solution Solenoid	24.4v - Solenoid Off
			0.12v - Solenoid On

Component Locations

The following components are included in this section:

- Solution Tank
- Solution Solenoid Valve
- Solution Ball Valve
- Water Filter
- 90° Ball Valve and Drain Hose
- Detergent Cartridge

The **Solution Tank** holds approximately 12 gallons of solution.



The **Solution Solenoid Valve** is mounted on the **Scrub Deck** and controls the solution flow to the scrub brush/pad.

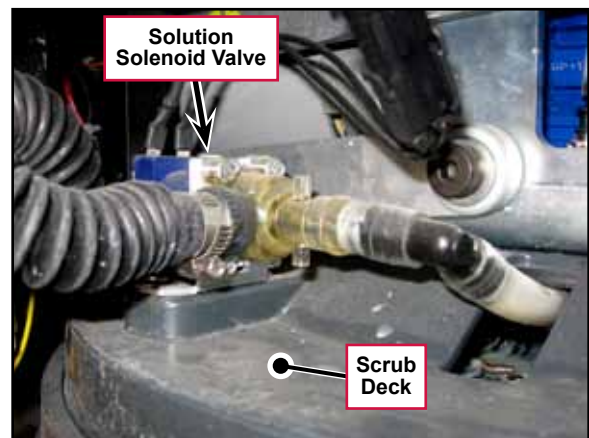

The solution **Ball Valve** controls the solution flow from the solution tank to the **Water Filter**.

The **Water Filter** filters the solution upstream of the solution solenoid valve.

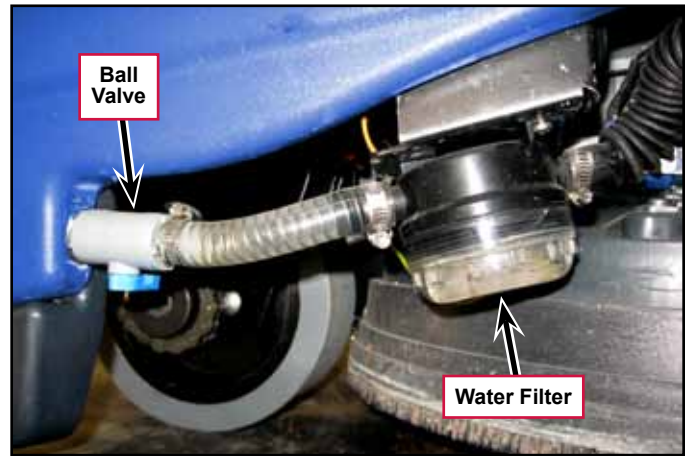

The **90° Ball Valve** and **Drain Hose** allow you to drain the solution tank.

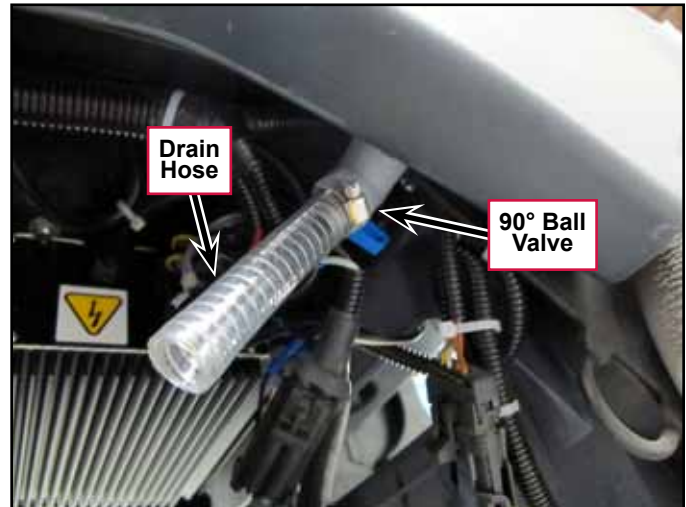

Maintenance

Cleaning the Water Filter

1. Close the solution **Ball Valve** to shut off the solution flow from the solution tank to the **Water Filter**.
1. Unscrew the **Filter Cap**.
1. Remove and clean the internal filter screen.
1. Reinstall the filter screen and **Filter Cap**.
1. Open the **Ball Valve** and check for leaks.

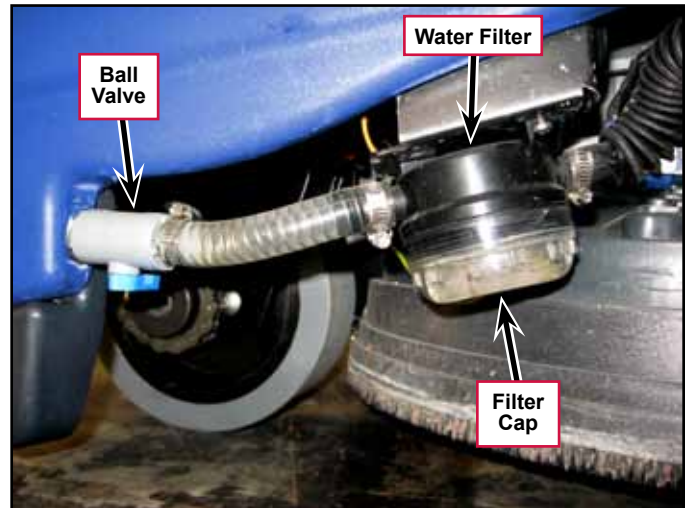

Troubleshooting

Problem	Cause	Correction
No solution to the Scrub Deck (scrub system is working).	Plugged Water Filter.	Clean or replace the Filter.
	Plugged solution line or ball valve.	Check the solution lines and ball valve and clear or replace as necessary.
	No voltage to the Solution Solenoid Valve.	<ol style="list-style-type: none"> 1. Check the voltage on pin J3-11 on the A1 Control Board. The signal, referenced to ground, should be approximately 24.4v with the Solution Solenoid off, 0.12v with the Solution Solenoid on. 2. Check the wiring from pin J3-11 on the A1 Control Board to the Solution Solenoid Valve and repair as necessary 3. Check the wiring from the Key Switch to the Solution Solenoid Valve and repair as necessary.
	The Solution Solenoid Valve is not operating correctly.	<ol style="list-style-type: none"> 1. Check the Solution Solenoid Valve coil resistance. If the resistance is not 55.5 Ohms $\pm 10\%$, replace the Valve. 2. If the Solution Solenoid Valve coil resistance is within spec, check for clogged ports, binding or a mechanical problem. Repair or replace the Valve as necessary.

Specifications

Component Specifications

Component	Specifications
Solution Solenoid Valve	Nominal Voltage – 24 VDC, 11 Watt
	Duty – Continuous
	Resistance – 55.5 Ohms $\pm 10\%$ @ 25° C
Solution Tank	Capacity – 12 gal. [45,4 l]

Nominal Solution Flow Rates

The nominal solution flow are listed in the following table. Note that these flow rates are based on a half-full solution tank.

Solution Setting	Deck Type	Nominal Flow Rate
Low	20" Disk	0.15 (gal./min.) / 0.57 l/min.
Medium	20" Disk	0.35 (gal./min.) / 1.32 l/min.
High	20" Disk	0.50 (gal./min.) / 1.89 l/min.

Squeegee System

Functional Description

The **Squeegee Assembly** is designed to be easily removed from its mounting hardware for cleaning and maintenance.

The **Rear Squeegee Strap** holds the **Rear Squeegee Blade** on the **Squeegee Casting**. The **Squeegee Cover** retains the **Front Squeegee Blade**.

The four **Knob Assemblies** fasten the **Squeegee Casting** and attached **Squeegee Blades** to the **Squeegee Cover**.

The spring-loaded **Squeegee Mount Bracket** clamps onto the screws on the **Squeegee Link Weldment**. The **Squeegee Link Weldment** attaches to a pivoting mount on the scrub deck that allows the **Squeegee Assembly** to rotate about the scrub deck. This allows the **Squeegee Assembly** to pick up wastewater with the machine moving around turns.

The **Vacuum Hose Assembly** attaches to the **Squeegee Casting** to pull the wastewater from the **Squeegee Assembly** up and into the recovery tank.

The **Caster Wheel** can be adjusted up and down to align the **Front** and **Rear Squeegee Blades** to the floor surface.

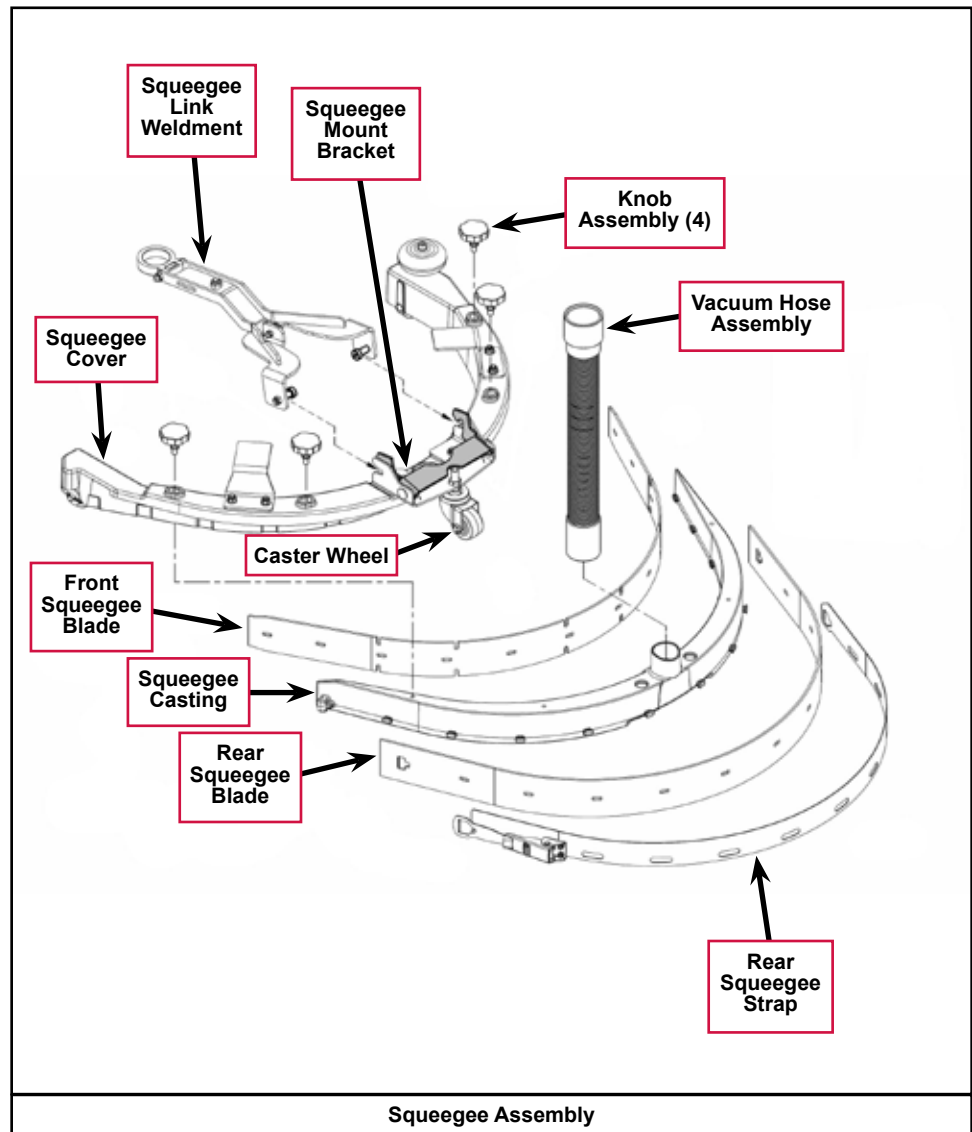

Component Locations

The following components are included in this section:

- Vacuum Hose Assembly
- Squeegee Link Weldment
- Knob Assemblies
- Squeegee Blades
- Squeegee Casting
- Caster Wheel
- Squeegee Mount Bracket
- Squeegee Cover.
- Rear Squeegee Strap

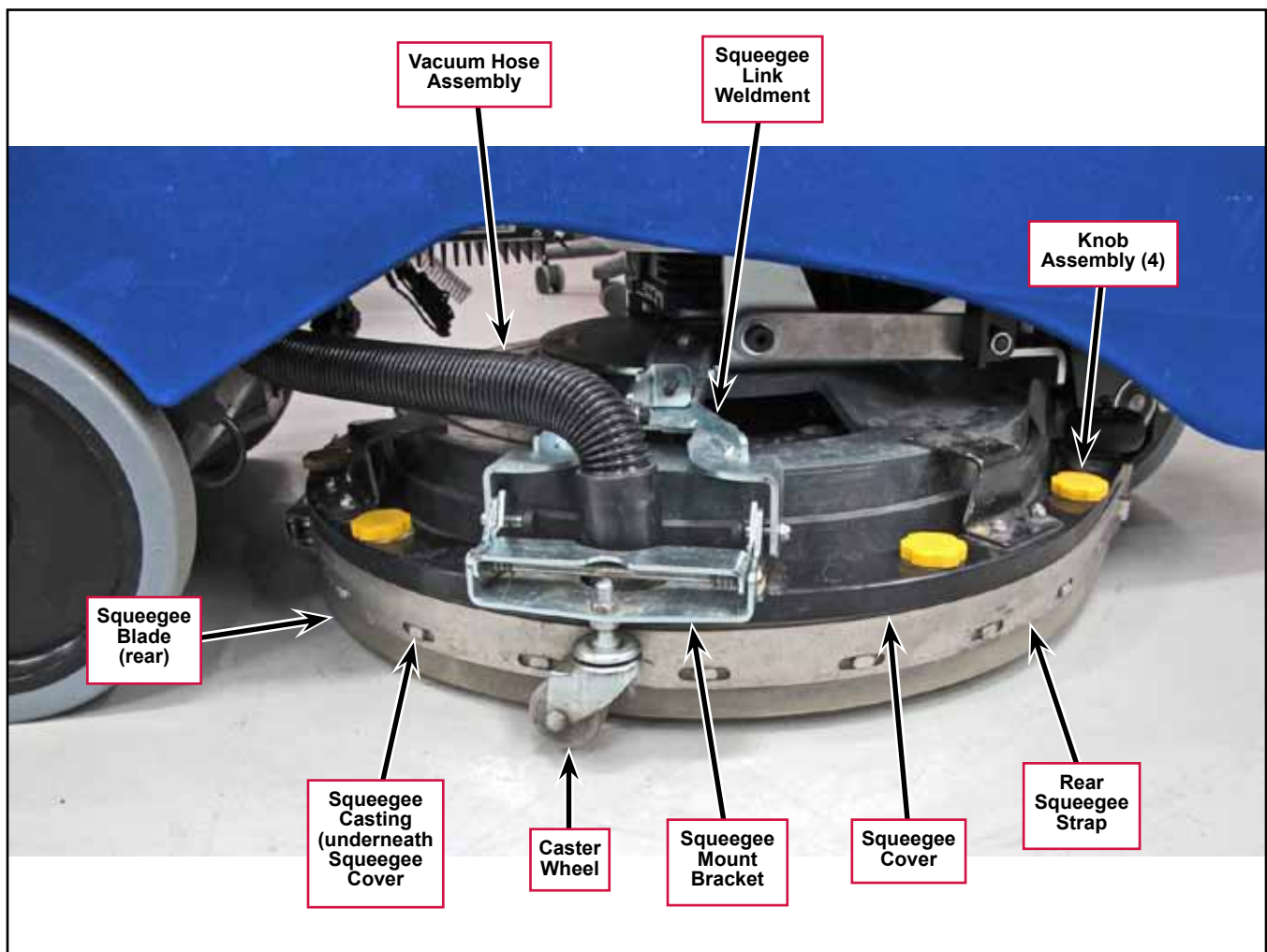

Troubleshooting

Problem	Cause	Correction
Poor water pick-up.	The squeegee blades are torn or worn.	Check and replace the blades as necessary.
	The squeegee assembly is out of adjustment.	Readjust the squeegee as follows: <ol style="list-style-type: none"> 1. Park the machine on a flat, even surface and lower the squeegee. 2. Drive the machine forward enough to have the squeegee blades fold over to the rear. 3. Adjust the squeegee tilt by adjusting the Caster Wheel height so the rear squeegee blade touches the floor evenly across its entire width and is bent over slightly. (Also refer to the Instructions for Use.)

Specifications

Component	Specifications	
Squeegee Blades	Available Materials	Red Gum Rubber (Natural Rubber)
		Polyurethane/Pentathane

Steering System

Functional Description

The **Steering Wheel** and attached **Steering Shaft** are connected to and rotate the **Upper Universal Joint**.

The **Upper Universal Joint** drives the **Hex Shaft** which drives the **Steering Tube Assembly**. Note that the **Hex Shaft** is designed to slide up and down in the **Steering Tube Assembly** when the Control Panel Housing/Recovery Tank Cover is opened and closed to maintain steering alignment.

The **Steering Tube Assembly** is connected to the **Lower Universal Joint** which drives the steering shaft coupled to the **11-tooth Sprocket**.

The **11-tooth Sprocket** drives the chain that rotates the **Steering Plate** to steer the **Drive Wheel Assembly** left and right.

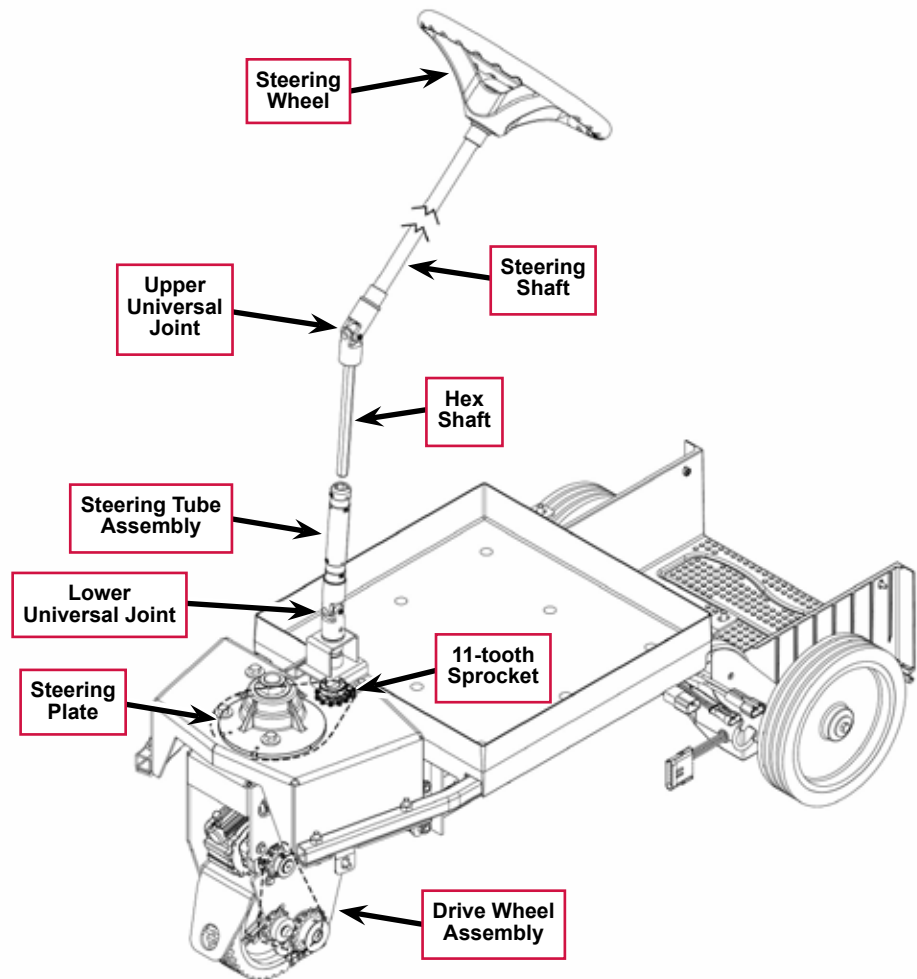

Component Locations

The following components are included in this section:

- Upper Universal Joint
- Hex Shaft
- Steering Tube Assembly
- Lower Universal Joint
- Steering Plate

The Upper Universal Joint, Hex Shaft and Steering Tube Assembly are located underneath the Recovery Tank Cover.

The upper and lower universal joints permit the rotational motion of the steering wheel to change direction from the angle of the steering wheel to the vertical direction at the steering chain.

The hex shaft slides within the steering tube, and permits the length of the shaft to vary without disconnecting the motion.

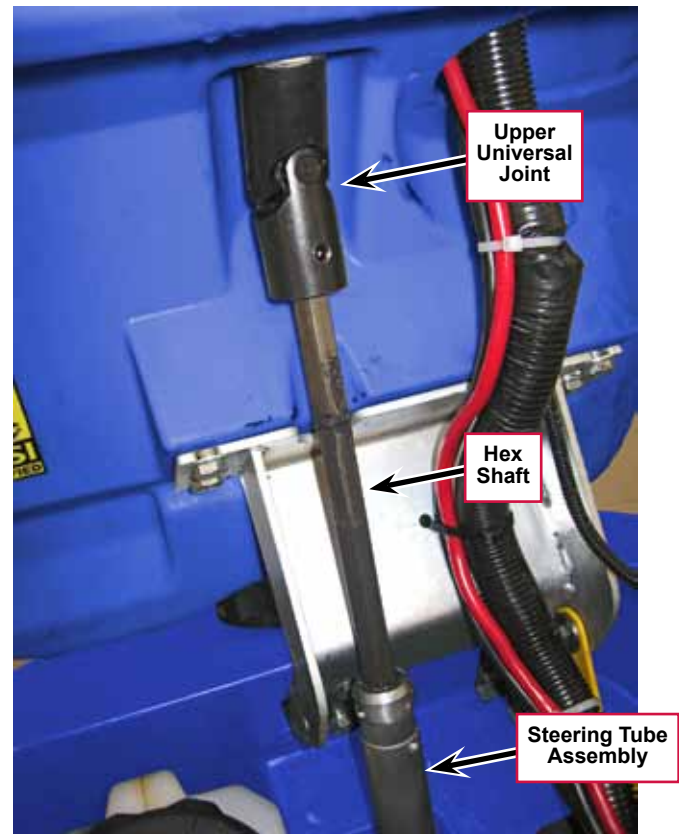

The Lower Universal Joint is connected to the Steering Tube Assembly and is located above the Steering Shaft Weldment.

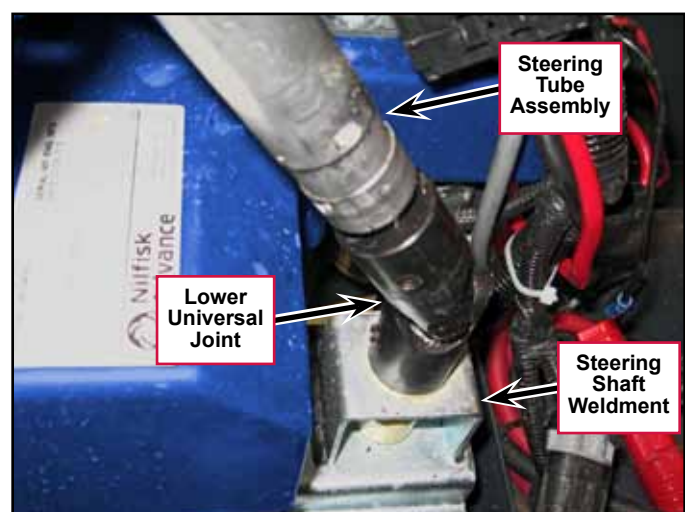

The **Steering Plate** is fastened to the top of the Drive Wheel Assembly and rotates the Drive Wheel Assembly to steer the machine left and right.



Troubleshooting

Problem	Cause	Correction
The steering is binding or the machine steers “hard”.	The upper and lower universal joints are “out of phase”.	Realign the upper and lower universal joints. (Refer to the <i>Wheel System - Traction/ Removal and Installation/Drive Wheel Assembly</i> subsection.)
	Lack of lubrication on the steering components.	Lubricate the steering components as recommend in the <i>General Information/Lubrication Locations</i> subsection.

Wheel System - Traction

Functional Description

The machine is propelled by the **Drive Wheel Assembly** which consists of a 24-volt DC **Drive Wheel Motor** and attached **Gearbox** that drive an **11-tooth Sprocket**. The **11-tooth Sprocket** drives the **Drive Wheel Roller Chain** that drives a **15-tooth Sprocket** connected to the **Drive Wheel**. An adjustable **Sprocket Assembly** acts as an idler to adjust the **Drive Wheel Roller Chain** tension.

The **Drive Wheel Motor and Gearbox** are fastened to the **Spacer** which is bolted to the **Drive Wheel Frame Weldment**. The two **Axle Bearings** are fastened to the bottom of the **Drive Wheel Frame Weldment** and support the **Axle** and **Drive Wheel**.

The **Steering Roller Chain** is driven by a sprocket connected to the steering wheel via the steering tube assembly and two U-joints. The **Steering Roller Chain** rotates the **Steering Plate** and attached **Drive Wheel Assembly** left and right to steer the machine.

A Curtis 1210 Speed Controller provides pulse-width modulated voltage to the **Drive Wheel Motor** to control the machine speed. The Speed Controller will alternate the voltage polarity to control the machine direction.

The Operator must be standing on the Operator Presence Pedal (referred to as the “Dead Man Switch, S2” in the Electrical Ladder Diagram) in order for the drive motor to operate. With the Operator standing on the Operator Presence Pedal, he/she selects the machine direction by pressing either the Forward Drive or Reverse Drive Switch, then depresses the Go Pedal (S5) to drive the machine.

Note that a brake, built in to the **Drive Wheel Motor**, will engage to hold the machine stationary whenever the key switch is Off or after a predetermined time delay when the key is off and the Go Pedal has not been pressed. When the Go Pedal is pressed, the Speed Controller energizes an electromagnetic solenoid to release the brake.

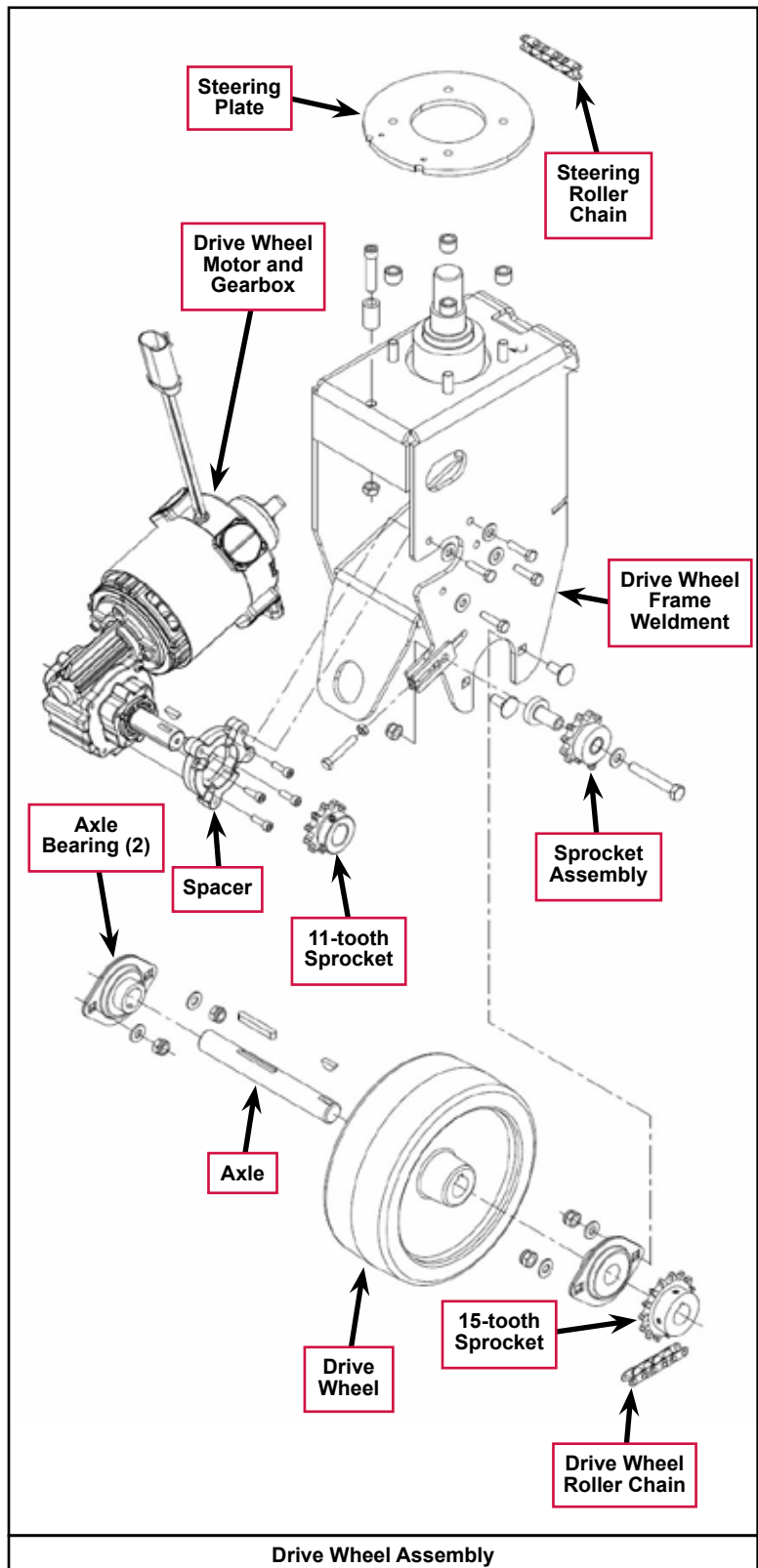

Wheel Drive Motor Circuit Descriptions

Power to the E1 Curtis 1210 Speed Controller

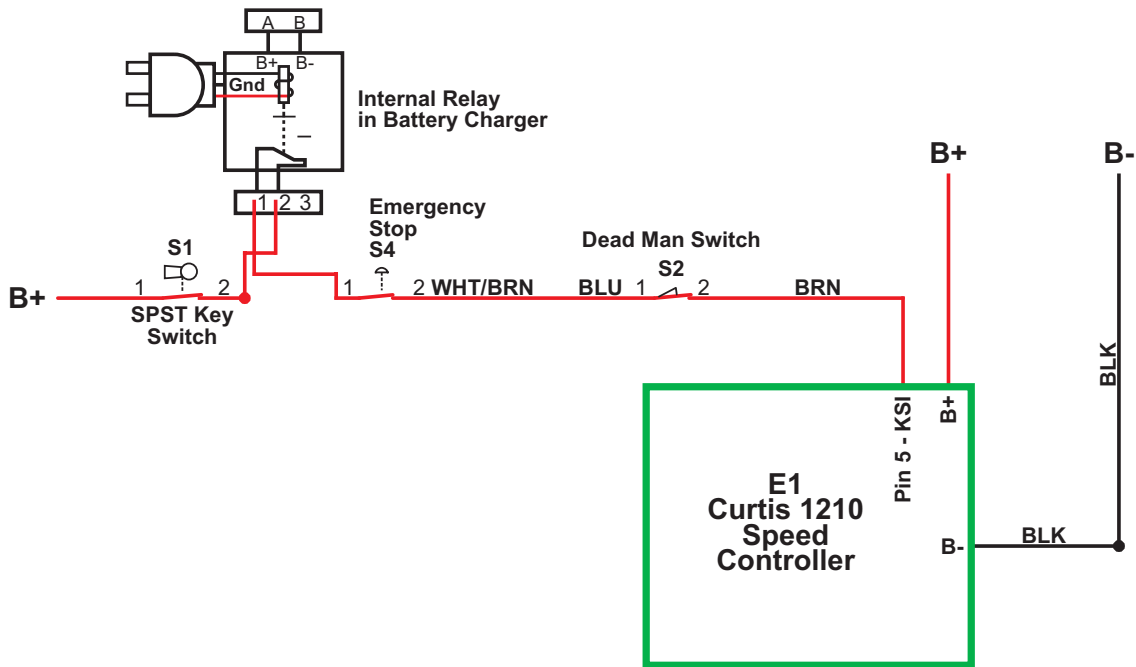

In order for positive voltage from the **SPST Key Switch** to reach **Pin 5 - KSI** (key switch input) on the **E1 Curtis 1210 Speed Controller**:

- The contacts in the **Internal Relay in Battery Charger** must be closed (charger unplugged).
- The **Emergency Stop S4** switch and **Dead Man Switch S2** must be closed.

If all of these condition are not met, the machine will not drive.

Speed Control Drive Functions

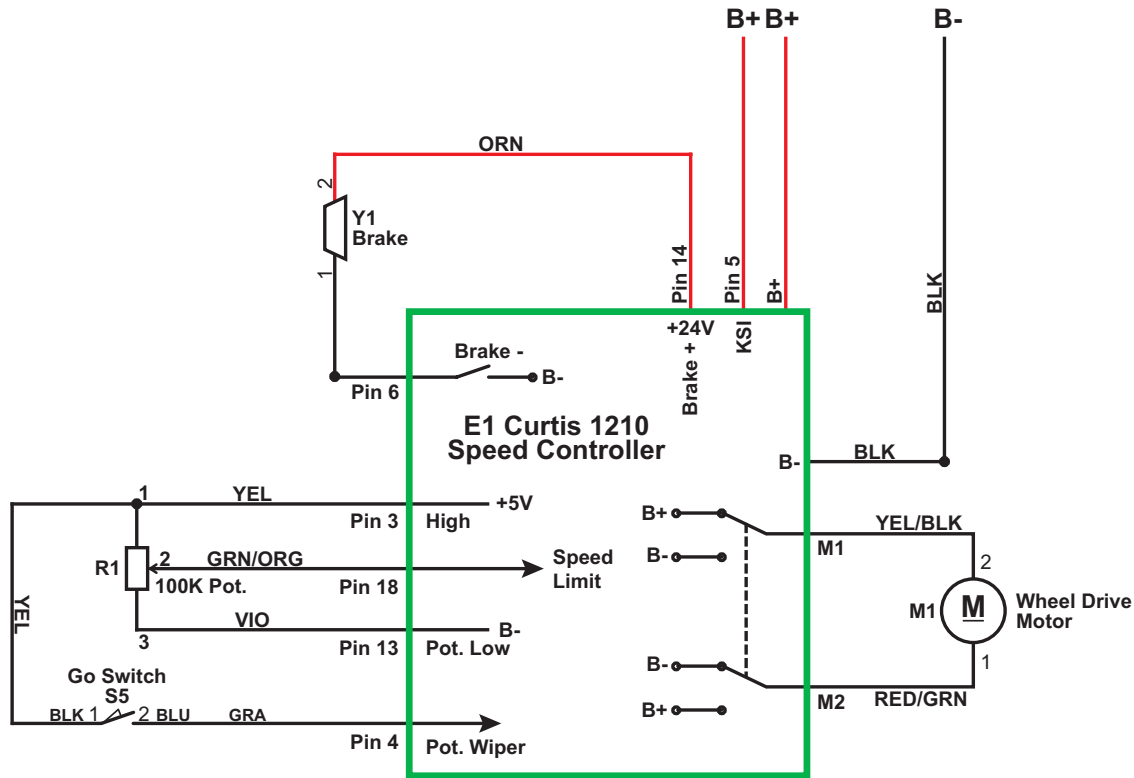

The **E1 Curtis 1210 Speed Controller** provides a regulated 5-volt supply out **Pin 3 - High** to the **100K Pot.** (speed potentiometer) and the **Go Switch S5**. When the Operator steps on the Go Pedal, the **Go Switch** closes and sends the 5 volts back to **Pin 4 - Pot. Wiper** on the **Speed Controller**.

Pin 13 - Pot. Low supplies an internal connection to battery negative inside the **Speed Controller**.

The **100K Pot.** sends a variable voltage signal BACK to the **Speed Controller** at **Pin 18 - Speed Limit**.

The **Speed Controller** provides a power supply out **Pin 14 - +24V Brake +** to the **Y1 Brake** solenoid.

Just before the **Speed Controller** provides power to the **Wheel Drive Motor**, it provides a path to ground for the electric **Y1 Brake** at **Pin 6 - Brake -** to energize the brake solenoid and release the brake. (The brake is spring-loaded and will apply whenever the brake solenoid is not energized.)

Speed Control Communication with the A1 Control Board

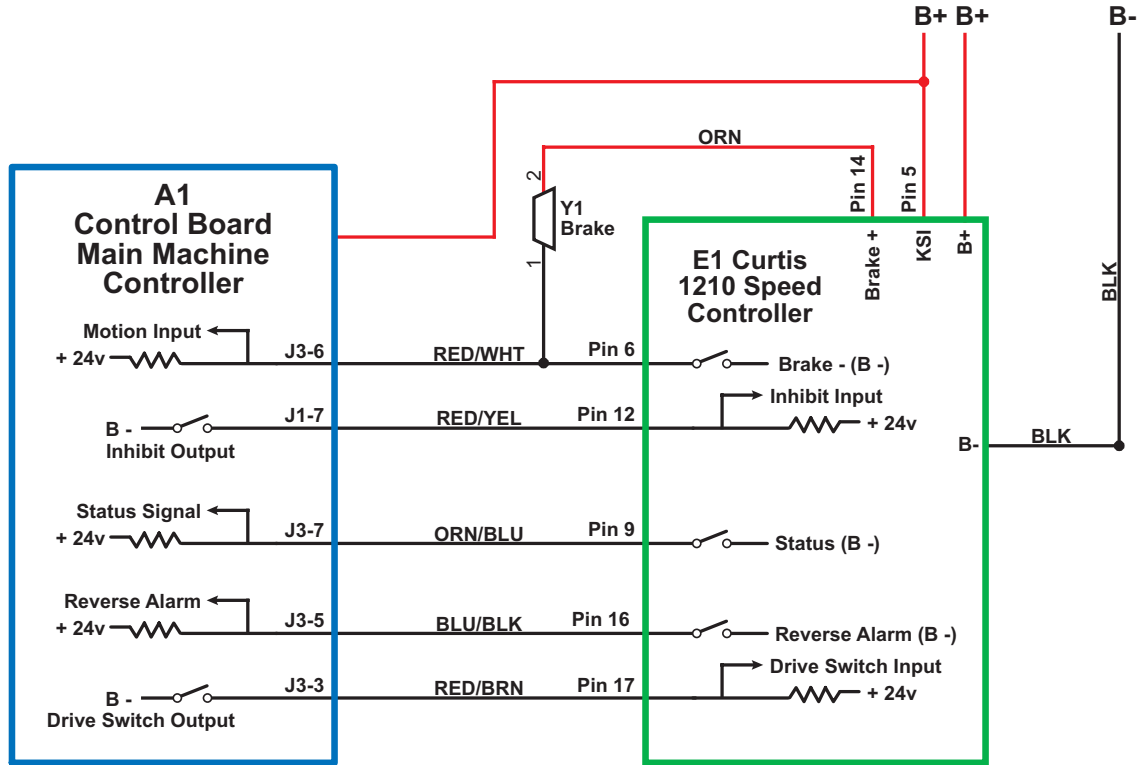

There are five “communication” wires that run between the **A1 Control Board** and the **E1 Curtis 1210 Speed Controller**. Each wire is used to communicate a unique piece of information as listed in the following table.

A1 Control Board Terminal	Speed Controller Terminal	Function
Motion Input J3-6	Pin 6 - Brake - (B -)	The A1 Control Board provides a positive 24-volt supply through a resistor and out of Motion Input J3-6 to a switch on Pin 6 - Brake - (B -) in the Speed Controller . The A1 Control Board monitors the voltage on the wire between J3-6 and Pin 6 . When the machine is standing still, the switch is open and the input is “high” or 24 volts. When the Speed Controller operates the wheel drive motor, it also closes the switch on Pin 6 to B - to let the A1 Control Board know that the machine is moving. When the switch on Pin 6 closes, the voltage on the wire drops to 0 volts.
Inhibit Output J1-7	Pin 12 - Inhibit Input	The A1 Control Board uses the inhibit signal to tell the Speed Controller when it is OK to propel the machine. If the Operator is not standing on the dead man switch or a direction has not yet been selected, the switch on J1-7 will be closed to B - . The Speed Controller will see a low signal (0 volts) at Pin 12 . When the dead man switch is closed and either a forward or reverse direction has been selected, the switch on J1-7 opens and the signal at Pin 12 becomes high (24 volts) to signal the Speed Controller that it is now Ok to propel the machine when the go pedal is pressed.

A1 Control Board Terminal	Speed Controller Terminal	Function
Status Signal J3-7	Pin 9 - Status (B -)	<p>The Speed Controller uses the status signal to tell the A1 Control Board when it has set a fault, and which fault is set. The switch on Pin 9 - Status (B -) opens and closes in a pattern to communicate a specific fault code to J3-7. That pattern is mirrored by the Forward or Reverse Indicators so you can read the fault. (Whichever direction LED that is not currently active will flash out the error code.)</p> <p>Like the other circuits, when the switch on Pin 9 is open, the signal at J3-7 is high (24 volts). When the switch on Pin 9 closes to B-, the signal voltage at J3-7 drops to low (0 volts).</p>
Reverse Alarm J3-5	Pin 16 - Reverse Alarm (B -)	<p>The reverse alarm signal circuit is identical to the Motion circuit. When not in reverse the switch on Pin 16 - Reverse Alarm in the Speed Controller is open, leaving the signal at J3-5 high (24 volts).</p> <p>When driving the wheel in reverse, the switch on Pin 16 closes to B - which drops the signal at J3-5 to low (0 volts), signalling the A1 Control Board that the machine is moving in reverse and that it should turn on the Reverse Alarm.</p>
Drive Switch Output J3-3	Pin 17 - Drive Switch Input	<p>The A1 Control Board uses the Drive Switch Output signal from J3-3 to signal the Speed Controller which direction the Operator wishes to propel the machine – forward or reverse.</p> <ul style="list-style-type: none"> • When the Operator selects the forward direction, the switch on J3-3 is closed to B - and the signal at Pin 17 - Drive Switch Input is low (0 volts). • When the Operator selects the reverse direction, the switch on J3-3 is open and the signal at Pin 17 - Drive Switch Input is high (24 volts).

Component Locations

The following components are included in this section:

- Drive Wheel Assembly
- E1 Curtis 1210 Speed Controller
- Speed Control Adjustment Knob/100k Speed Control Potentiometer
- Drive Wheel Brake

The **Drive Wheel Assembly** is fastened to the machine frame underneath the front of the machine. (Note that the adjacent photo shows the machine lying on its side.)



The **E1 Curtis 1210 Speed Controller** is located inside the control panel assembly.



The Speed Adjustment Knob controls the 100K Speed Control Potentiometer, labeled R1 in the Wiring Diagram. The Speed Adjustment Knob is mounted on the control panel and controls the machine speed in both forward and reverse.

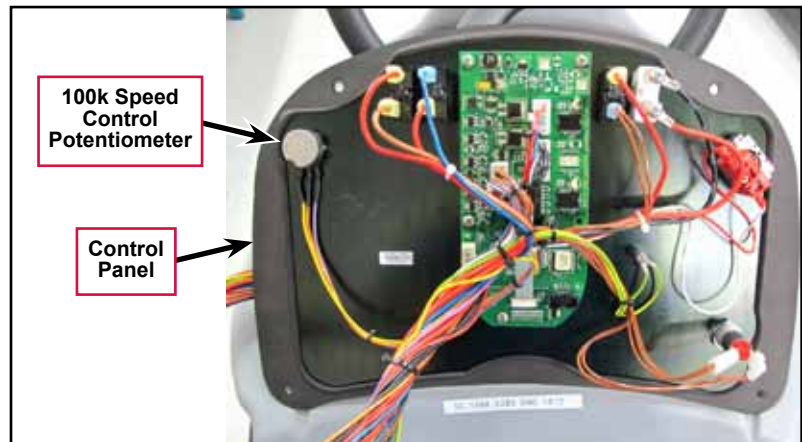
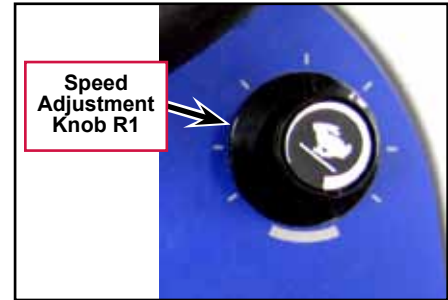

The **Drive Wheel Brake** is built in to the Drive Wheel Motor and will engage to stop the machine whenever the key switch is Off or the Go Pedal is released.

When the Go Pedal is pressed, the Speed Controller energizes an electromagnetic solenoid to release the **Drive Wheel Brake**.



Maintenance and Adjustments

Speed Control Programming Options

The following table lists the Speed Control parameters that can be accessed and changed using the 1311 Programmer. Note that these parameters normally do not need to be changed, and should not be changed arbitrarily.

Parameter as listed on the 1311 Programmer	Range	Default	Factory Setting	Units	Function
Accel Max Speed	0.2-4.0	3.0	4.0		Sets the forward acceleration rate with the speed potentiometer set at maximum. Smaller numbers provide faster response.
Accel Min Speed	0.2-8.0	3.0	4.0		Sets the forward acceleration rate with the speed potentiometer set at minimum. Smaller numbers provide faster response.
Reverse Accel Max	0.2-8.0	3.0	5.0		Sets the reverse acceleration rate with the speed potentiometer set at maximum. Smaller numbers provide faster response.
Reverse Accel Min	0.2-8.0	3.0	5.0		Sets the reverse acceleration rate with the speed potentiometer set at minimum. Smaller numbers provide faster response.
M1 Max Speed	0-100	80	100	%	The speed requested in forward with the throttle and speed limit pot set to maximum in mode 1.
M2 Max Speed	0-100	100	100	%	The speed requested in forward with the throttle and speed limit pot set to maximum in mode 2.

Troubleshooting

General Troubleshooting



use the Service Test Mode to simplify troubleshooting the Drive Wheel System. (Refer to the **Controls System/Service Test Mode**.)

Problem	Cause	Correction
Machine not moving in forward or reverse.	The Speed Adjustment Knob is set too low.	Rotate the Speed Adjustment Knob to a higher speed setting.
	Discharged batteries..	Check the battery voltage and charge as necessary.
	The E1 Curtis Speed Controller not receiving input requests from the A1 Control Board for travel.	<ol style="list-style-type: none"> 1. Make sure the Speed Controller is sending signals to the A1 Control Board that indicate it is trying to move the machine. 2. If the Speed Controller is sending signals to the A1 Control Board, check to see if there is voltage across the motor terminals. If the voltage is above 6 volts and the drive motor is not turning, the motor is the problem (check the carbon brushes).
	No voltage to the drive motor.	<ol style="list-style-type: none"> 1. Check the wiring from the Speed Controller to the drive motor and repair as necessary. 2. If the wiring is OK, replace the Speed Controller.

E1 Curtis Speed Controller Diagnostics

Diagnostics Method A - Graphic Display and Direction Indicator

Diagnostics Method A uses the machine’s graphic display and Forward/Reverse Direction Indicator (LED) to show the Speed Controller fault codes. The E1 Curtis Speed Controller will output a fault code if it detects a problem associated with the Speed Controller and wheel drive system.

If a speed control fault occurs, the graphic display will show the wrench icon and Control Board fault **03**.



When the 03 is displayed the Forward or Reverse Indicator (that is not already active) will flash a special error code sequence until the fault is corrected. See the “[Status LED Fault Code Table](#)” on page 117 for a description of the fault indications.



Service Note: This is how to read the error code status light:
 For example, OO O = two light flashes, a short pause, one flash, then a long pause, then the code will be repeated. This indicates a fault code 2,1.



Diagnostics Method B - Curtis Programmer

Diagnostics Method B uses the optional hand-held Curtis programmer model 1311. With a programmer, diagnostics and troubleshooting are more direct than with the Direction Indicator LED alone. The programmer presents complete diagnostic information in plain language with no codes to decipher. The **LCD Display** shows faults on the Diagnostic Menu and the controller input/output status on the Test Menu.

- **Navigation Key** – used to move around through the programmer menus.
- **Parameter Modification Key** – used to increase and decrease values.
- **Bookmark Keys** – used for jumping back and forth between fields.

The following five-step process is generally used for diagnosing and troubleshooting an inoperative machine:

1. Visually inspect the machine for obvious problems.
2. Diagnose the problem using the programmer.
3. Test the circuitry with the programmer.
4. Correct the problem.
5. Repeat the last three steps as necessary until the vehicle is operational.

Refer to the “[Status LED Fault Code Table](#)” on page 117 for suggestions covering a wide range of possible faults.

Diagnostic History

You can use the handheld programmer to access the controller’s diagnostic history:

The programmer will read out all the faults that the controller has experienced since the last time the diagnostic history file was cleared. The faults may be intermittent faults, faults caused by loose wires or faults caused by Operator errors. Faults such as HPD or over-temperature may be caused by Operator habits or by overloading.

After a problem has been diagnosed and corrected, it’s recommended that you clear the diagnostic history file. This allows the controller to accumulate a new file of faults. By checking the new diagnostic history file at a later date, you can readily determine whether the problem was indeed completely fixed.

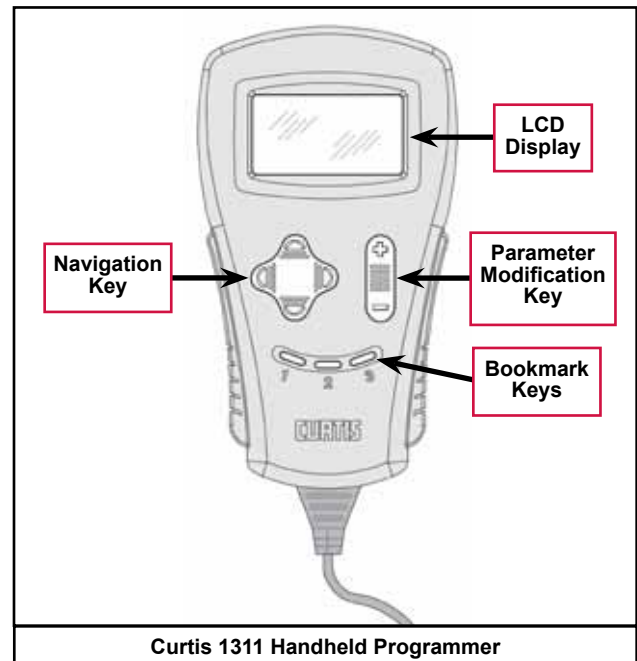

Status LED Fault Code Table

LED Code	Status Light Display	Explanation	Possible Cause
1,1	0 0	Over-/under-temperature cutback	<ol style="list-style-type: none"> 1. Temperature >92°C or < -25°C 2. Excessive load on vehicle 3. Operation in extreme environments 4. Electromagnetic brake not releasing.
1,2	0 00	Throttle fault	<ol style="list-style-type: none"> 1. Throttle input wire open or shorted 2. Wrong throttle type selected
1,3	0 000	Speed limit pot fault	<ol style="list-style-type: none"> 1. Speed limit pot wire(s) broken or shorted 2. Broken speed limit pot
1,4	0 0000	Battery voltage too low	<ol style="list-style-type: none"> 1. Battery voltage <17 volts 2. Bad connection at battery or controller
1,5	0 00000	Battery voltage too high	<ol style="list-style-type: none"> 1. Battery voltage >36 volts 2. Vehicle operating with charger attached 3. Intermittent battery connection
2,1	00 0	Main contactor driver Off fault	Main contactor driver failed open
2,3	00 000	Main contactor fault	<ol style="list-style-type: none"> 1. Main contactor welded or stuck open 2. Main contactor driver fault 3. Brake coil resistance too high
2,4	00 0000	Main contactor driver On fault	Main contactor driver failed closed
3,1	000 0	HPD fault present for >10 sec.	<ol style="list-style-type: none"> 1. Misadjusted throttle 2. Broken throttle pot or throttle mechanism
3,2	000 00	Brake On fault	<ol style="list-style-type: none"> 1. Electromagnetic brake driver shorted 2. Electromagnetic brake coil open
3,3	000 000	Pre-charge fault	<ol style="list-style-type: none"> 1. Low battery voltage 2. KSI and throttle turned on at same time
3,4	000 0000	Brake Off fault	<ol style="list-style-type: none"> 1. Electromagnetic brake driver open 2. Electromagnetic brake coil shorted
3,5	000 00000	HPD (High Pedal Disable) fault	<ol style="list-style-type: none"> 1. Incorrect sequence of throttle and KSI,** push, or inhibit inputs 2. Misadjusted throttle pot
4,1	0000 0	Current sense fault	<ol style="list-style-type: none"> 1. Short in motor or in motor wiring 2. Controller failure *
4,2	0000 00	Motor voltage fault (hardware failsafe)	<ol style="list-style-type: none"> 1. Motor voltage does not correspond to throttle request 2. Short in motor or in motor wiring 3. Controller failure *
4,3	0000 000	EEPROM fault	EEPROM failure or fault
4,4	0000 0000	Power section fault	<ol style="list-style-type: none"> 1. EEPROM failure or fault 2. Short in motor or in motor wiring 3. Controller failure *

* Jack up vehicle and retest to confirm diagnosis. Clean the connections, inspect system wiring, then retest.

**Note: A KSI (key switch Input) system problem is a specific HPD (high pedal disable) type operational fault caused by the Operator pressing the Operator Presence Pedal before turning on the main key switch. This can be cleared by releasing the Operator Presence Pedal, then cycling the key switch OFF and ON.

Removal and Installation

Drive Wheel Assembly

1. Loosen the Setscrew holding the Steering Assembly Tube in the lower Universal Joint.

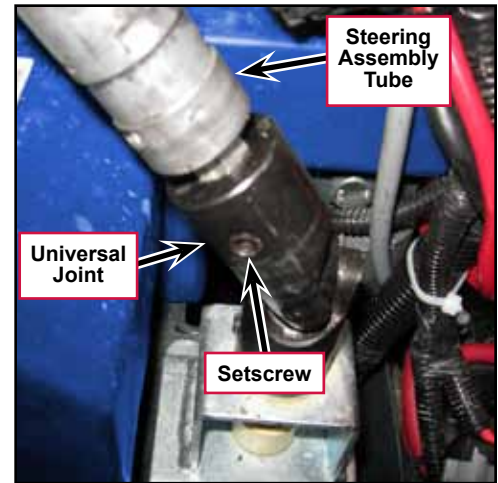

2. Disconnect the upper Drive Motor and Brake Electrical Connectors.



Service Tip: You may find it easiest to lay the machine down on a raised, padded surface when removing the drive wheel assembly. In this case you'll need to drain the solution and recovery tanks, remove the batteries and remove the tip pads.

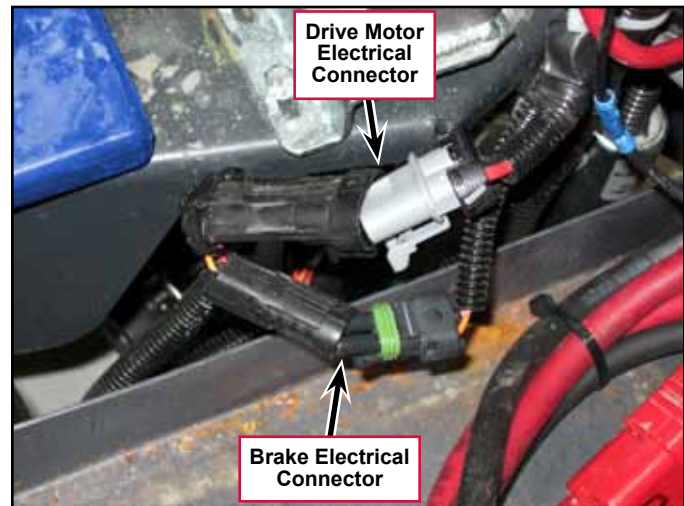

3. Drain the solution and recovery tanks.
4. Disconnect and remove the batteries.
5. Remove the four M8 x 30 Screws and flat washers holding each of the two Tip Pads to the machine and remove the Tip Pads.



Caution: Tipping the machine on its side without first removing the Tip Pads can damage the Tip Pads and strip the molded-in fasteners out of the solution tank.

6. Carefully lay the machine down on a clean, padded surface.



Caution: The machine is heavy. Make sure you have the adequate manpower available to lay the machine on its side without causing any personal injury or machine damage.

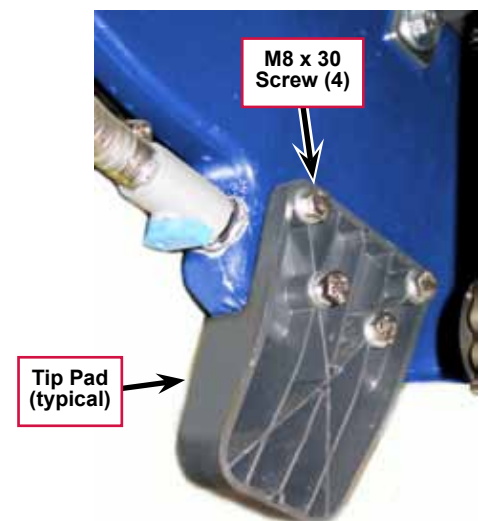

- Remove the four M8 x 45 Screws and flat washers, then remove the Drive Wheel Assembly and attached Spindle Mount Weldment from the machine.

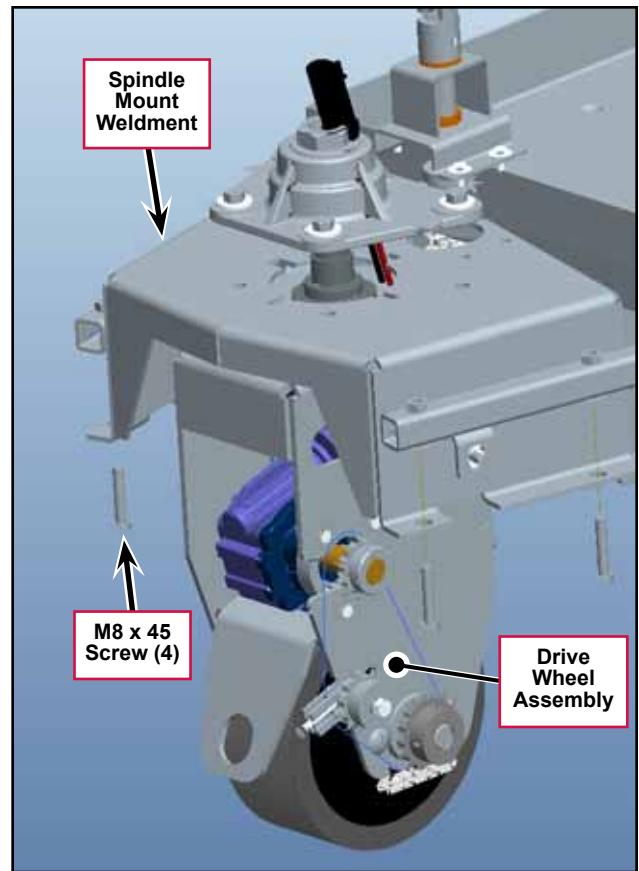
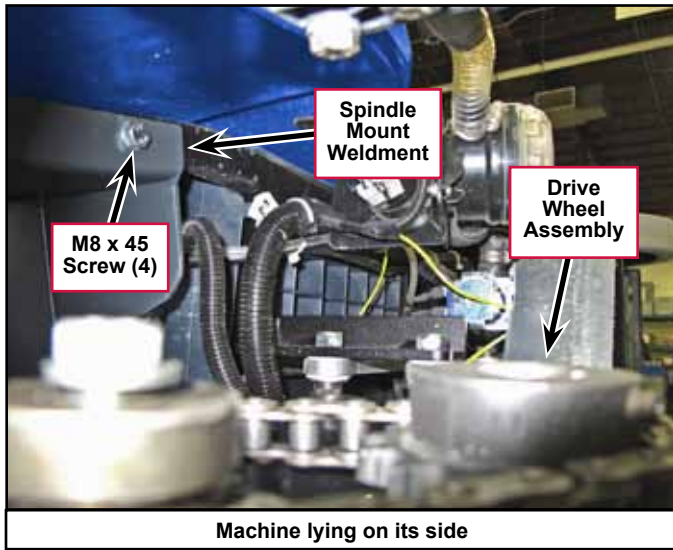

- To reinstall the Drive Wheel Assembly and attached Spindle Mount Weldment, follow the above steps in reverse order.



Service Tip: Make sure the axes of the two Universal Joints are parallel when you reconnect the Steering Assembly Tube to the Lower Universal Joint. If the two Universal Joints are “out of phase”, the steering system will bind.

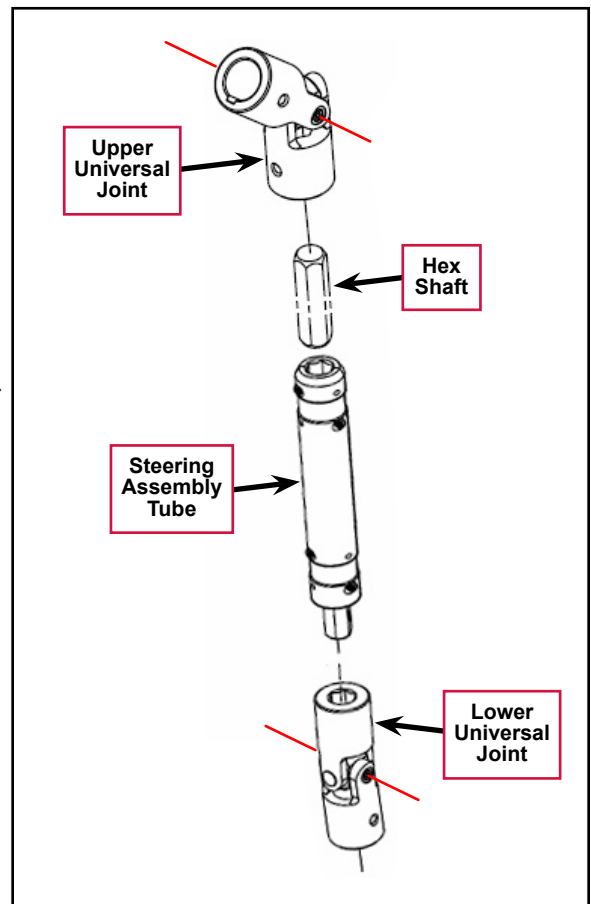

Drive Wheel Motor

1. Remove the [Drive Wheel Assembly](#) described on page 118
2. Loosen the M6 Locknut, then back the M6 x 35 Idler Adjuster Screw out of the Idler Adjust Weldment.
3. Hold the Nyloc® nut on the M8 x 55 Screw with a wrench and loosen the M8 x 55 Screw.
4. Slide the Idler Adjust Weldment and Sprocket Assembly as necessary to get some slack in the Chain.

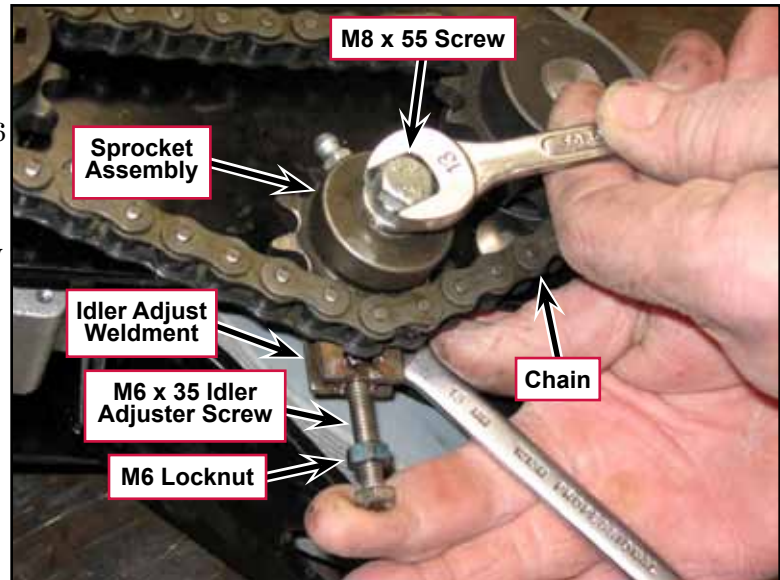

5. Remove the Master Link and remove the chain.

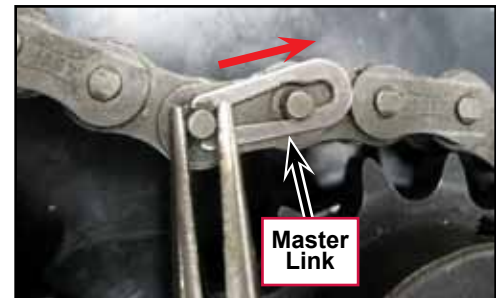

6. Disconnect the lower Drive Motor and Brake Electrical Connectors.

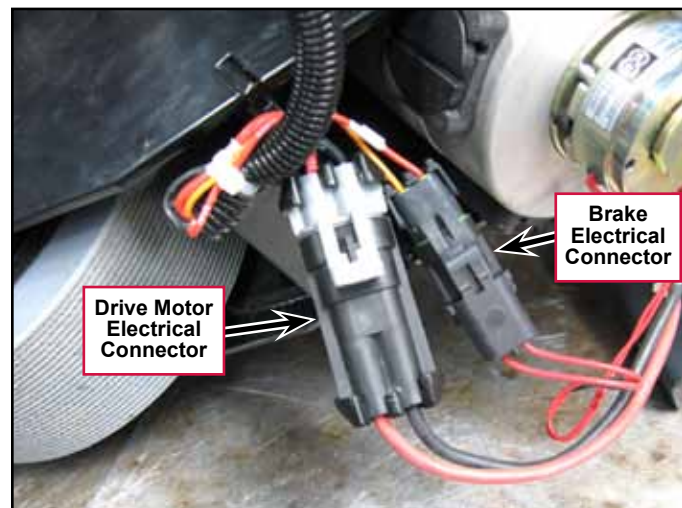

7. Remove the four M6 x 25 Screws and flat washers, then remove the Drive Motor from the Drive Wheel Frame Weldment.
8. To reinstall the Drive Motor into the Drive Wheel Frame Weldment, follow the above steps in reverse order.



Service Tip: When you set the chain tension with the M6 x 35 Idler Adjuster Screw, adjust the Screw so the chain deflects approximately $\frac{1}{4}$ " to $\frac{1}{2}$ " to when pressed with moderate force.

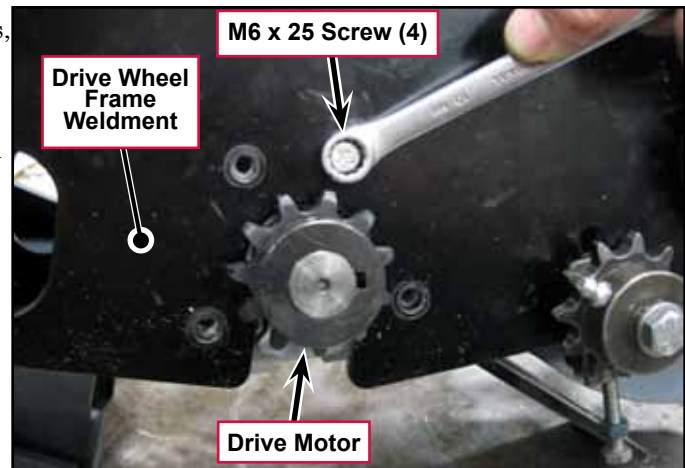

Steering Spindle Bearings

1. Remove the [Drive Wheel Assembly](#) described on page 118.
2. Remove the [Drive Wheel Motor](#) described on page 120.
3. Remove the three M6 x 14 Screws and flat washers holding the Steering Shaft Weldment to the Spindle Mount Weldment.
4. Remove the chain from the sprocket on the Steering Shaft Weldment, then remove the Steering Shaft Weldment and attached parts from the Spindle Mount Weldment.

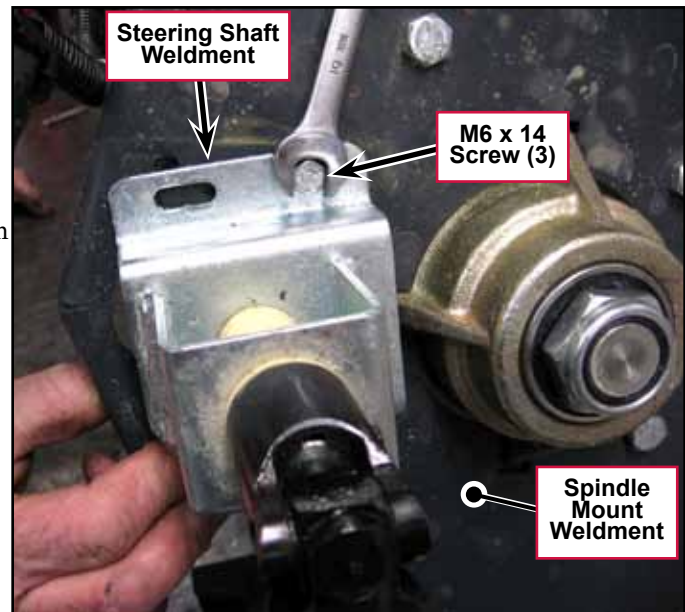

5. Remove the 1"-14 Nyloc® Nut from the Spindle Weldment.



6. Carefully remove the Shaft Seal, Bearing Cup and Bearing Cone from the Bearing Block.
7. Replace the Shaft Seal, Bearing Cup or Bearing Cone as necessary. Make sure the Bearing Cone is greased adequately with a high-quality lithium-base grease before reassembly.

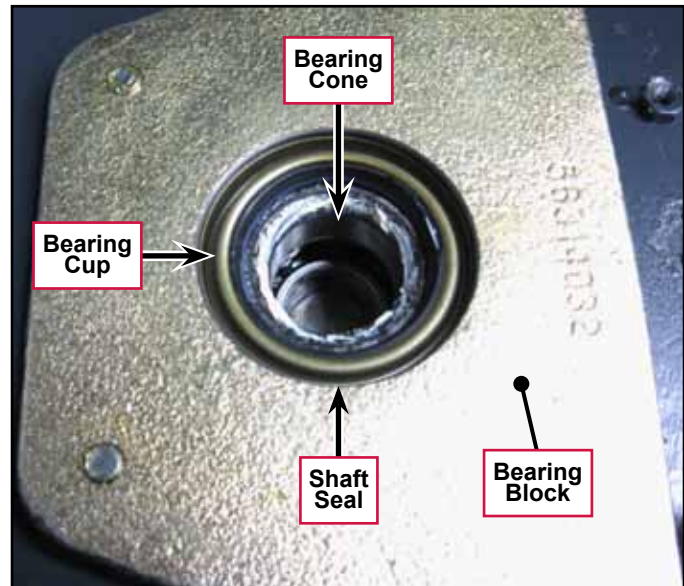
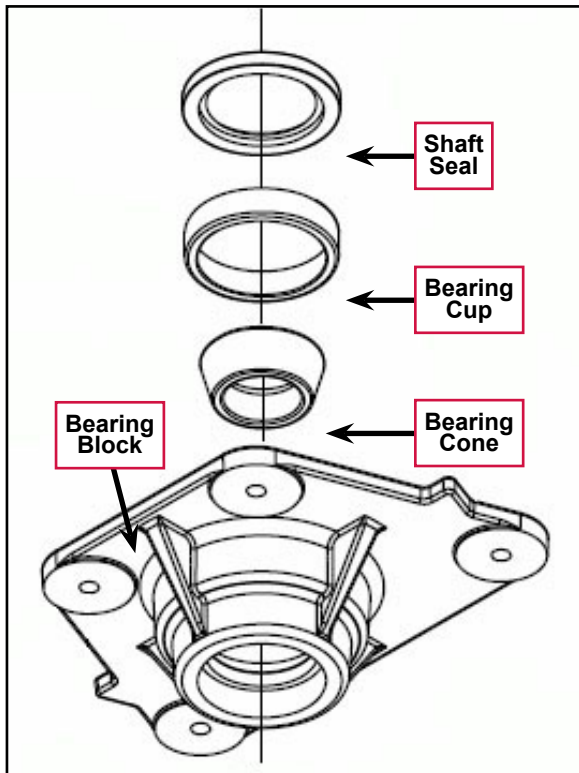

8. Remove and replace the Ball Bearing as necessary.

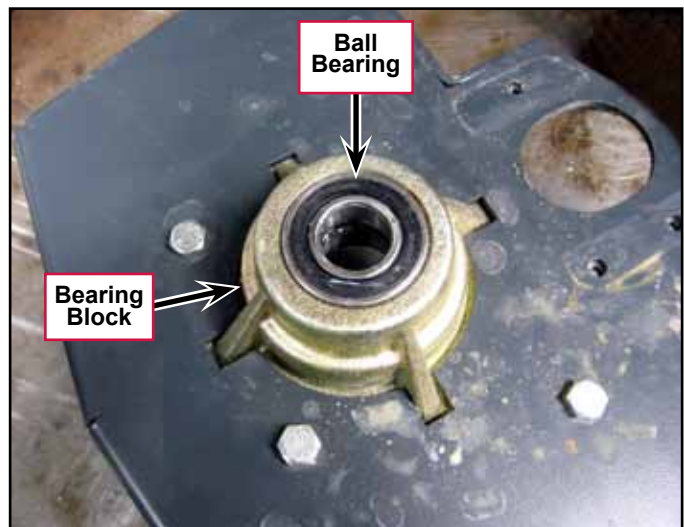
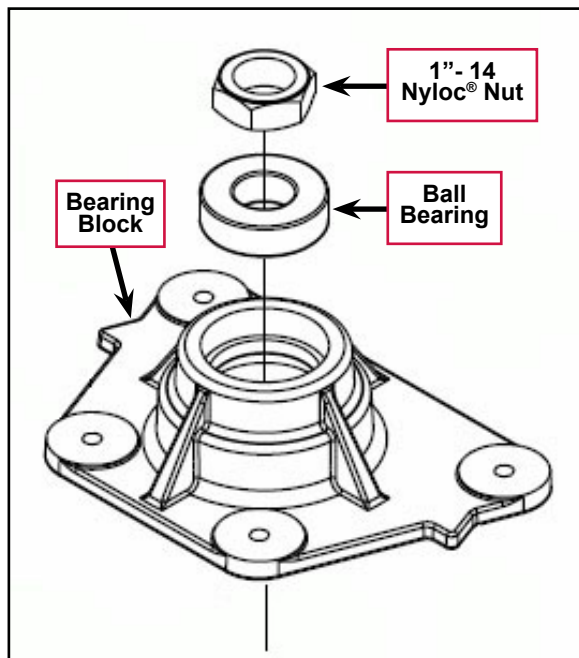

9. Reassemble the Drive Wheel Assembly by following the above steps in reverse order. Note that when you reinstall the 1"-14 Nyloc® Nut onto the Spindle Weldment, torque the Nut to 20 ft.-lbs.

Drive Wheel Motor Maintenance

Replacing the Motor Brushes

1. Remove the [Drive Wheel Assembly](#) described on page 118.
2. Remove the [Drive Wheel Motor](#) described on page 120.
3. Remove the Cap holding the brush in the motor.



4. Carefully pry out the old Brush from the motor.
5. Install a new Brush, then reinstall the Cap.
6. Reinstall the Drive Motor into the Drive Wheel Frame Weldment.
7. Reinstall the Drive Wheel Assembly and attached Spindle Mount Weldment into the machine.

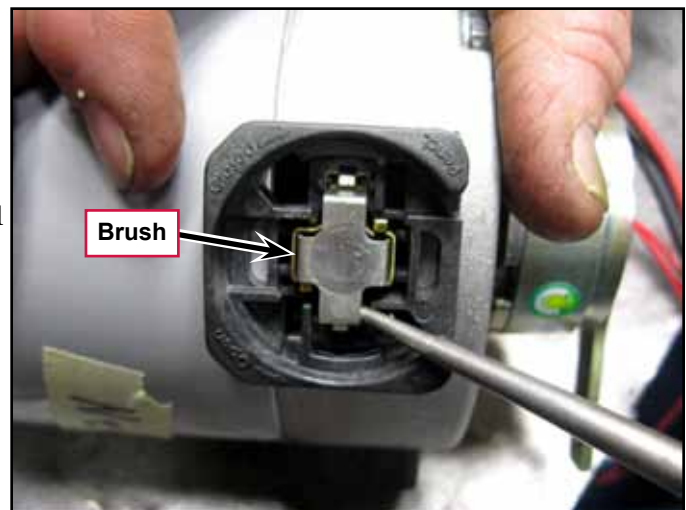

Specifications

Shop Measurements

The following table lists measurements taken from one SA40. While these are not “specifications”, they can help you recognize abnormal vs. normal conditions.

Note that the black voltmeter lead is on B- unless otherwise indicated.

E1 Curtis 1210 Speed Controller – Low Current

Pin	Color	Description	Ref.	Measurements
1	-			
2	-			
3	YEL	POT High	B-	4.96v
4	GRA	POT Wiper	B-	4.96v Go Switch Pressed 0.004v not pressed
5	BRN	KSI	B-	24.03v (all “interlock” switches closed)
6	RED/WHT	Brake -	B-	22.2v off (brake applied) 0.1v on (brake released)
7	-			
8	-			
9	ORN/BLU	Status	B-	Unstable voltage when there is a code. If unplugged, 23v from A1 control board.
10	-			
11	-			
12	RED/YEL	Inhibit	B-	0v no direction request 23.2v FWD or REV requested 23.9v unplugged (v source is A1 control board)
13	VIO	POT Low	B-	0.03v
14	ORN	Brake +	B-	23.9v (out to brake solenoid)
15	-			
16	BLU/BLK	Rev. Alarm	B-	0v no direction request or forward request 23.1v reverse direction request 23v unplugged (v source is A1 control board)
17	RED/BRN	Reverse	B-	22.7 Reverse Requested 0.002v Forward requested or no direction 22.7v unplugged (v source is A1 control board)
18	GRN/ORN	Speed Limit	B-	0.028v minimum 4.96v maximum

E1 Curtis 1210 Speed Controller – Output

Pin	Ref.	Measurements
M1	B-	FWD low speed 12.6v FWD high speed 23.4v REV low speed 11 v REV high speed 3.9v
M2	B-	FWD low speed 11.2v FWD high speed 0.17v REV low speed 12v REV high speed 20v
M1	M2	FWD low speed 1.5v FWD high speed 23.2v REV low speed -1.3v REV high speed -16v

General Specifications

Component	Specifications	
Drive Wheel Motor	Current Draw	No load – 3 to 4 Amps
		Full speed transport – 7 to 10 Amps
		Full speed scrub – 8 to 16 Amps) (depending on floor conditions)
E1 Curtis 1210 Speed Controller	Voltage Rating – 24 VDC	
	Drive Current – Up to 70 Amps	

Special Tools

