



## Electronic Service Manuals

This electronic document is provided as a service to our customers. We do not create the contents of the information contained in this document. Should you have detailed questions pertaining to the information contained in this document, you may contact Michco, or the manufacturer which provided the original information in this electronic deliverable. Michco's only part in this electronic deliverable was the electronic assembly process. By providing this manual on line we are not guaranteeing parts availability.

You may contact Michco through the following methods:

Phone (517) 484-9312 or (800) 331-3339

2011 N. High St. -- Lansing, Michigan -- 48906

Fax: (517) 484-9836

Email: [CustServe@Michco.com](mailto:CustServe@Michco.com)

Web site: [www.Michco.Com](http://www.Michco.Com)

Parts Web site: [www.FloorMachineParts.Com](http://www.FloorMachineParts.Com)

Order Parts on Line at:

**[www.FloorMachineParts.Com](http://www.FloorMachineParts.Com)**

Directly to Parts & Service:

By Email: **[Shop@Michco.com](mailto:Shop@Michco.com)**

By Fax: (517) 702-2041

By Voice: Use numbers above.

**Serving the Cleaning Industry Since 1922**

Notice: All copyrighted material remains property of original owners, all trademarks are property of respective owners. Manuals are subject to Manufacturer's reproduction limitations. Originals or reproductions were provided by manufacturers through a request. We make no warranty as to the correctness of information provided in this document and you assume all risk. By placing these manuals on line we are not declaring our corporation to be an manufacturer authorized dealer or provider, please check our web site for authorized manufacturers we represent.



**Operator's Manual**  
Libro De Instruccion  
Manuel D'utilisation

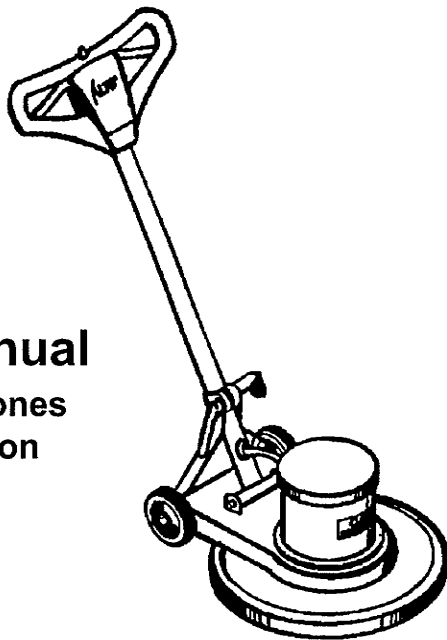

**C2K Series**  
**120V**  
**Polisher**

### **READ THIS BOOK**

**▲ CAUTION:** Read the Operator's Manual before using the appliance.

This book has important information for the use and safe operation of this machine. Failure to read this book prior to operating or attempting any service or maintenance procedure to your ALTO machine could result in injury to you or to other personnel; damage to the machine or to other property could occur as well. You must have training in the operation of this machine before using it. If your operator cannot read this manual, have it explained fully before attempting to operate this machine.

All directions given in this book are as seen from the operator's position at the rear of the machine.

For new books write to: ALTO U. S. Inc., 2100 Highway 265, Springdale, Arkansas 72764.

## CONTENTS OF THIS BOOK

Operator Safety Instructions .....	5
Machine Introduction .....	6
Accessories .....	11
Machine Specifications .....	14
How To Prepare the Machine for Operation .....	18
How to Install the Brush or Pad Driver .....	18
How to Adjust the Handle .....	18
Instructions for Connection to Power Supply & Elect. Ground, 120V .....	20
How to Operate the Machine .....	22
How To Start/Stop The Machine .....	22
How to Control the Machine .....	22
Maintenance .....	22
 <b>Section II Parts and Service Manual</b>	
Maintenance .....	26
Assembly Drawing .....	28
Assembly Parts List .....	29
Assembly Drawing .....	30
Assembly Parts List .....	31
Motor Assembly Drawing & Parts List .....	32
Gearbox Assembly Drawing & Parts List .....	33
Gearbox Assembly Drawing & Parts List .....	34
Motor Assembly Drawing & Parts List .....	35
Gearbox Assembly Drawing & Parts List .....	36
Motor Assembly Drawing and Parts List .....	37
Gearbox Assembly Drawing and Parts List .....	38
Wiring Diagrams .....	39

C2K Series  
LIBRO DE INSTRUCCIONES

LEA ESTE LIBRO

 **CUIDADO:** Lea el Libro de Instrucciones antes de usar este aparato. Contiene información importante para el uso y funcionamiento correcto y seguro de la máquina. Lea este libro completamente antes de arrancar la máquina o hacer cualquier operación de mantenimiento. Si no sigue las instrucciones, corre el peligro de herirse o causar lesiones al personal, o causar daños importantes a la máquina o a su entorno. Antes de usar la máquina, es indispensable seguir una formación. Si Usted (o el operador) no habla español, solicite (o proporcionele) todas las informaciones necesarias. El libro está traducido en otros idiomas. Todas las indicaciones de dirección dadas en este libro están dadas desde la posición del operador en la parte de atrás de la máquina. Puede Ud. conseguir libros suplementarios dirigiéndose a su distribuidor ALTO.

---

**INDICE**

Instrucciones de seguridad para el operador .....	7
Presentación de la máquina .....	8
Accesorios .....	12
Especificaciones de la pulidora C2K .....	15
Preparación de la máquina para trabajar .....	19
Instalación del cepillo o del portadisco .....	19
Reglaje de la tobera .....	19
Instrucciones para la conexión con la red 120 V .....	21
Funcionamiento de la máquina .....	23
Arranque y paradá .....	23
Dominio del desplazamiento de la máquina .....	23
Mantenimiento .....	23

**SECCION II PIEZAS Y SERVICIO**

Mantenimiento .....	27
---------------------	----

## OPERATOR SAFETY INSTRUCTIONS



**WARNING**



**AVERTISSEMENT**



**ADVERTENCIA**

<b>DANGER</b> means:	Severe bodily injury or death can occur to you or other personnel if the <b>DANGER</b> statements found on this machine or in this Owner's Manual are ignored or are not adhered to. Read and observe all <b>DANGER</b> statements found in this Owner's Manual and on your machine.
<b>WARNING</b> means:	Injury can occur to you or to other personnel if the <b>WARNING</b> statements found on your machine or in this Owner's Manual are ignored or are not adhered to. Read and observe all <b>WARNING</b> statements found in this Owner's Manual and on your machine.
<b>CAUTION</b> means:	Damage can occur to the machine or to other property if the <b>CAUTION</b> statements found on your machine or in this Owner's Manual are ignored or are not adhered to. Read and observe all <b>CAUTION</b> statements found in this Owner's Manual and on your machine.



**DANGER:** Failure to read the Owner's Manual prior to operating or attempting any service or maintenance procedure to your machine could result in injury to you or to other personnel; damage to the machine or to other property could occur as well. You must have training in the operation of this machine before using it. **If you or your operator(s) cannot read English, have this manual explained fully before attempting to operate this machine.**



**DANGER:** To reduce the risk of fire, use only commercially available floor cleaners and waxes intended for machine application.



**DANGER:** Risk of explosion. Floor sanding can result in an explosive mixture of fine dust and air. To reduce risk of explosion, use floor sanding machine only in well ventilated area.



**DANGER:** Operating a machine that is not completely or fully assembled could result in injury or property damage. Do not operate this machine until it is completely assembled. Inspect the machine carefully before operation.



**DANGER:** Electrocutation could occur if maintenance and repairs are performed on a unit that is not disconnected from the power source. Disconnect the power supply before attempting any maintenance or service. Always remove the electrical plug from the electrical outlet before changing the brush, pad or other attachment and before leaving the machine.



**DANGER:** Using a machine with a damaged power cord could result in an electrocution. Do not use the machine if the power cord is damaged. Do not use the electrical cord to move the machine.



**WARNING:** Maintenance and repairs performed by unauthorized personnel could result in damage or injury. Maintenance and repairs must be performed by authorized personnel only. Keep all fasteners tight. Keep adjustments according to specifications.



**WARNING:** Electrical components of this machine can "short-out" if exposed to water or moisture. Keep the electrical components of the machine dry. Wipe the machine down after each use. For storage, keep the machine in a dry building.



**WARNING:** Always use a three-wire electrical system connected to the electrical ground. For maximum protection against electric shock, use a circuit that is protected by a ground fault interrupter. Consult your electrical contractor.









**WARNING:** To prevent damage to the power cord, do not let the brush, pad, pad driver or wheels touch the power cord when the machine is running. Always lift the cord over the machine. Do not pull the power cord to move the machine.



**WARNING:** Operating a machine without observing all labels and instructional information could result in injury or damage. Read all machine labels before attempting to operate. Make sure all of the labels and instructional information are attached or fastened to the machine. Get replacement labels and decals from your authorized distributor.

---

## OPERATOR SAFETY INSTRUCTIONS (cont.)

-  **WARNING:** Use of this machine as a step or furniture could result in injury or damage. Do not use this machine as a step or furniture. Do not ride on this machine.
-  **WARNING:** To avoid injury keep hands, feet and loose clothing away from all moving parts of this machine.
-  **WARNING:** Injury to operator or bystanders could occur if an abrupt change in floor surface texture is encountered when using this machine. Abrupt change in floor surface texture can cause a sudden pulling motion by this machine. This sudden pulling motion can result in loss of control of the machine which could injure the operator or bystanders. Avoid motions that could cause machine to cross from a smooth floor surface to a carpeted or rough texture floor surface. Avoid motions that could allow the machine to come in contact with low obstacles, such as floor electrical outlets, door stops or entry molding, etc.
-  **WARNING:** Water solutions or cleaning materials used with this type of machine can leave wet areas on the floor surface. These areas can cause a dangerous condition for the operator or other persons. Always put CAUTION signs near the area being cleaned.
-  **WARNING:** Any alterations or modifications of this machine could result in damage to the machine or injury to the operator or other bystanders. Alterations or modifications not authorized by the manufacturer voids any and all warranties and liabilities.
-  **CAUTION:** The machine is heavy. Get assistance before attempting to transport or move it.

**NOTE:** This machine is intended for commercial use.

---

## MACHINE INTRODUCTION

### The CLARKE TECHNOLOGY C2K Series

The C2K Series are floor maintaining machines that can be used for polishing, spraying, buffing, stripping and shampooing. The machines can be used on wood, vinyl, terrazzo or cement floors. With the shampoo brush, the machines can be used to clean carpet and with the sanding disc they can be used to sand floors.

## INSTRUCCIONES PARA LA SEGURIDAD DEL OPERADOR



**WARNING**



















**AVERTISSEMENT**



**¡ AVISO !**

- ¡ PELIGRO ! :** Si no sigue la indicación **PELIGRO**, se pueden causar lesiones graves, incluso mortales. Lea y siga todas las indicaciones **PELIGRO** que se encuentran en el libro y en la máquina.
- ¡ AVISO ! :** Si no sigue la indicación **AVISO**, se pueden causar lesiones sea al operador sea a otro personal y/o daños materiales. Lea y siga todas las indicaciones **AVISO** que se encuentran en el libro y en la máquina.
- ¡ CUIDADO ! :** Si no sigue la indicación **CUIDADO**, se puede estropear la máquina o causar daños materiales. Lea y siga las indicaciones **CUIDADO** que se encuentran en el libro y en la máquina.

-  **¡ CUIDADO !** Siempre lea este libro de instrucciones antes de arrancar la máquina o hacer un mantenimiento. A falta de esta precaución, corre el peligro de herirse o causar lesiones a colegas ; podría Ud. también causar daños a la máquina o a su lugar de trabajo. Se debe aprender el manejo de esta máquina antes de usarla. Si Usted (o su plantilla) no conoce el español, se ruega dejarse explicar todo el libro antes de usar la máquina.
-  **¡ CUIDADO !** Para evitar un peligro de incendio, use sólo productos de limpieza y cera para el suelo especialmente concebidos para máquinas.
-  **¡ CUIDADO !** Peligro de explosión : mientras apomaza un parqué, una mezcla explosiva de partículas de polvo y aire puede formarse. Para reducir el peligro de explosión, use la máquina sólo en locales perfectamente ventilados.
-  **¡ CUIDADO !** Si usa una máquina antes de que esté completamente montada, corre el peligro de herirse o causar daños materiales. No opere la máquina antes de que esté completamente montada. Compruebe cuidadosamente el estado de la máquina antes de cada utilización.
-  **¡ CUIDADO !** Si efectúa un mantenimiento o una reparación sin desconectar la máquina, hay un riesgo de electrocución. Desconecte el enchufe de la caja conectada con la red antes de empezar el mantenimiento o la reparación. Siempre desconecte el enchufe de la caja de enchufe conectada con la red antes de cambiar el cepillo, el disco o cualquier otro accesorio y si deja la máquina sin vigilarla.
-  **¡ CUIDADO !** Si opera la máquina con un cable de alimentación estropeado, se puede causar una electrocución. No use nunca la máquina si el cable de alimentación está estropeado. No tire de la máquina usando el cable eléctrico.
-  **¡ AVISO !** Una reparación o un mantenimiento efectuado por personas no cualificadas puede causar lesiones y/o daños materiales. Todas las operaciones de mantenimiento o de reparación de la máquina deben ser efectuadas por técnicos cualificados. Compruebe que las fijaciones están correctamente apretadas. Haga reglajes conforme a las indicaciones dadas en el libro.
-  **¡ AVISO !** Hay un riesgo de cortocircuito si los componentes eléctricos de una máquina están expuestos a la humedad o son mojados. Procure que los componentes eléctricos sean siempre secos. Seque cuidadosamente la máquina después de cada utilización. Guarde la máquina en un local seco.

-  **AVISO !** Use siempre un cable con tres conductores puestos a tierra. Para una protección óptima, conecte la máquina con una caja de enchufe conectada con la red que tiene un diferencial. Si tiene alguna duda, sírvase acudir a un eléctrico cualificado.
-  **AVISO !** Para evitar daños al cable de alimentación, procure que el cepillo, el disco, el portadisco o las ruedas no toquen el cable, cuando la máquina funciona. Levante siempre el cable por encima de la máquina. No tire de la máquina para acercarla a la máquina.
-  **AVISO !** Si usa la máquina sin respetar todas las instrucciones escritas en los adhesivos y los carteles, corre el peligro de causar lesiones y daños materiales. Lea todas las indicaciones escritas en la máquina antes de la primera utilización. Compruebe que todos los adhesivos y las instrucciones estén colocados en los sitios previstos. Si es preciso, haga un nuevo pedido a su distribuidor Clarke Technology.
-  **AVISO !** No use la máquina como escabel o mueble. Corre el peligro de causar lesiones o daños materiales. No use la máquina como medio de transporte.
-  **AVISO !** Para evitar herirse, sírvase mantener una distancia de seguridad suficiente entre las partes móviles de la máquina y sus manos o sus pies. No lleve ropas holgadas.
-  **AVISO !** Una modificación brusca de la textura del suelo puede causar un sobresalto de la máquina de la cual el operador pierde momentáneamente el dominio. Eso puede causar lesiones al operador o a otras personas encontrándose cerca. Procure que la máquina no pase de una superficie lisa a una alfombra o una superficie más rugosa. Procure que la máquina no esté en contacto con cajas de enchufe colocadas en el suelo, topes de puerta o casquillos, etc.
-  **AVISO !** Las soluciones acuosas o los productos de limpieza usados con esta máquina pueden dejar zonas húmedas en el suelo, que pueden ser causa de peligro para el operador u otras personas. Ponga siempre señales de PRECAUCION cerca de la superficie que está limpiando.
-  **AVISO !** Esta máquina pesa. Transpórtela o desplácela con ayuda de otra persona.

**NOTA : Esta máquina es de uso comercial.**

---

## PRESENTACION DE LA MAQUINA

### Modelos CLARKE TECHNOLOGY Serie C2K

Estos modelos se concibieron para el mantenimiento del suelo y pueden ser utilizados para el pulido, el alisado, el decapado y la limpieza con champú. Son convenientes para los suelos de madera, de vinilo, de terrazo o de cemento. Con el cepillo de champú se puede limpiar el alfombra, mientras que el disco de pulido se usa para pulir los suelos.

## INSTRUCTIONS POUR LA SECURITE DE L'OPERATEUR



**WARNING**



**AVERTISSEMENT**



**AVISO !**

### **DANGER!**

Le non-respect des consignes précédées du mot DANGER peut occasionner des blessures graves, voire entraîner la mort. Lisez et respectez toutes les consignes DANGER figurant dans ce manuel et sur la machine.

### **AVERTISSEMENT**

Le non-respect des consignes AVERTISSEMENT peut entraîner des blessures pour l'opérateur ou d'autres membres du personnel et/ou occasionner des dégâts matériels. Lisez et respectez toutes les consignes AVERTISSEMENT figurant dans ce manuel et sur la machine.

### **ATTENTION**

Le non-respect des consignes signalées par le mot ATTENTION peut entraîner des dégâts à la machine ou dans son environnement. Lisez et observez toutes les consignes ATTENTION figurant dans ce manuel et sur la machine.



**DANGER !**

Lisez toujours ce manuel d'instructions avant de mettre la machine en service ou de procéder à un entretien. A défaut, vous risqueriez de vous blesser ou de blesser des collègues de travail; vous pourriez également provoquer des dégâts à la machine ou sur votre lieu de travail. Vous devez avoir reçu une formation avant d'utiliser la machine. Si vous (ou les membres de votre personnel) ne connaissez pas le français, veuillez vous faire expliquer le manuel complètement avant de commencer à utiliser la machine.



**DANGER !**

Pour éviter tout risque d'incendie, n'utiliser que des produits de nettoyage et des cires pour sol spécialement conçus pour un usage en machine



**DANGER !**

Risque d'explosion : lors du ponçage d'un parquet, un mélange explosif de particules de fine poussière et d'air peut se former. Pour réduire le risque d'explosion, n'utiliser la machine que dans des locaux parfaitement ventilés.



**DANGER !**

Si vous utilisez une machine avant qu'elle ne soit complètement montée, vous risquez de vous blesser ou de provoquer des dégâts matériels. Ne mettez pas la machine en service avant qu'elle ne soit complètement montée. Vérifiez soigneusement l'état de la machine avant chaque utilisation.



**DANGER !**

Si vous procédez à un entretien ou à une réparation sans avoir débranché la machine, il y a risque d'électrocution. Débranchez la fiche de la prise réseau avant de commencer tout entretien ou toute réparation. Débranchez toujours la fiche de la prise réseau avant de changer la brosse, le disque ou tout autre accessoire et si vous laissez la machine sans surveillance.



**DANGER !**

L'utilisation d'une machine lorsque le câble d'alimentation est endommagé peut provoquer une électrocution. Ne jamais utiliser la machine si le câble d'alimentation est endommagé. Ne pas utiliser le câble électrique pour tirer la machine.



**AVERTISSEMENT**

Un entretien ou des réparations effectués par des personnes non qualifiées risque de provoquer des blessures et/ou des dégâts matériels. Tous les travaux d'entretien ou de réparation de la machine doivent être effectués par des techniciens qualifiés. Bien veiller à ce que les fixations soient correctement serrées. Effectuer les réglages conformément aux indications figurant dans le manuel.



**AVERTISSEMENT**

Risque de court-circuit si les composants électriques d'une machine ont été exposés à l'humidité ou sont mouillés. Veillez à ce que les composants électriques soient toujours secs. Essuyer soigneusement la machine après chaque utilisation. Entreposer la machine dans un local sec.

## ACCESSORIES

The following accessories are available.

1. Polishing and waxing brushes.
2. Brushes with natural or synthetic bristles for scrubbing.
3. Brushes with steel wire bristles.
4. Synthetic pad holders.
5. Synthetic pads for polishing, scrubbing, stripping and spray buffing.
6. Brushes with metal or wood backs and with holes to let the solution flow through.
7. Solution tank.
8. Sanding discs.
9. Solution Buff Accessory

Model C2K-	16	18	160	180	200	1600	1800
Code Number	01194A	01195A	01196A	01197A	01198A	01199A	01200A
Solution Tank Assembly	50026A	50026A	50026A	50026A	50026A	50026A	50026A
Spray Buff Attachment	-----	-----	-----	-----	-----	-----	-----
Weight Kit	-----	-----	-----	-----	-----	10086A	10086A
Polypropylene Scrub Brush	51704A	51706A	51704A	51706A	51707A	51704A	51706A
Standard Pad Driver	50864A	50865A	50864A	50865A	50866A	50864A	50865A
Perma Grip Pad Driver	53159A	53157A	53159A	53157A	53156A	53159A	53157A
Super Grip Drive Pad	37007A	37009A	37007A	37009A	37011A	37007A	37009A
Carpet Nylon Brush	-----	-----	-----	-----	-----	51498A	51701A
High Speed Pad Driver	-----	-----	-----	-----	-----	-----	-----
Sanding Disc Driver	-----	-----	-----	-----	-----	450214	460215
Abrasive Coated Tynex	-----	-----	51443A	51445A	51446A	51443A	51445A
Steel Wire Brush	410963	410984	410963	410984	480924	410963	410984
Capture (Carpet) Scrub Brush	-----	-----	-----	-----	-----	-----	11405A
Grinding Disk Assembly	-----	-----	-----	-----	-----	450212	500212
Dust Skirt Kit	10087A	10088A	10087A	10088A	10089A	10087A	10088A

Model C2K-	2000	160HS	180HS	200HS	1600DS	2000DS
Code Number	01201A	01202A	01203A	01204A	01205A	01206A
Solution Tank Assembly	50026A	50026A	50026A	50026A	50026A	50026A
Spray Buff Attachment	-----	440570	440570	440570	440570	440570
Weight Kit	10086A	-----	-----	-----	10086A	10086A
Polypropylene Scrub Brush	51707A	51704A	51706A	51707A	51704A	51707A
Standard Pad Driver	50866A	50864A	50865A	50866A	50864A	50866A
Perma Grip Pad Driver	53156A	53159A	53157A	53156A	53159A	53156A
Super Grip Drive Pad	37011A	37007A	37009A	37011A	37007A	37011A
Carpet Nylon Brush	-----	-----	-----	-----	-----	-----
High Speed Pad Driver	-----	53154A	53153A	17518A	53154A	17518A
Sanding Disc Driver	-----	-----	-----	-----	-----	-----
Abrasive Coated Tynex	51446A	-----	-----	-----	-----	-----
Steel Wire Brush	480924	-----	-----	-----	-----	-----
Capture (Carpet) Scrub Brush	11406A	-----	-----	-----	-----	-----
Grinding Disk Assembly	-----	-----	-----	-----	-----	-----
Dust Skirt Kit	10089A	10087A	10088A	10089A	10087A	10089A

**⚠ WARNING: Use only brushes and accessories supplied by the manufacturer.**

## ACCESORIOS

Los accesorios siguientes son disponibles :

1. Cepillos para encerar y pulir.
2. Cepillos para fregar con filamentos en fibras naturales o sintéticas.
3. Cepillos de alambre de acero.
4. Portadiscos sintéticos.
5. Discos sintéticos para pulir, fregar, decapar y lustrar con tampón.
6. Cepillos con el dorso de metal o de madera y con canales para dispersar la solución.
7. Depósito de solución.
8. Discos para pulir.
9. Juego de accesorios para lustrar por pulverización con tampón.

Modelo C2K	16	18	160	180	200	1600	1800
Número de código	01194A	01195A	01196A	01197A	01198A	01199A	01200A
Conjunto de depósito de solución	50026A	50026A	50026A	50026A	50026A	50026A	50026A
Conjunto del vaporizador	-----	-----	-----	-----	-----	-----	-----
Juego de pesas	-----	-----	-----	-----	-----	10086A	10086A
Cepillo de polipropileno para fregar	51704A	51706A	51704A	51706A	51707A	51704A	51706A
Portadisco con sujeción Standard	50864A	50865A	50864A	50865A	50866A	50864A	50865A
Portadisco con sujeción Perma Grip	53159A	53157A	53159A	53157A	53156A	53159A	53157A
Portadisco con sujeción Super Grip	37007A	37009A	37007A	37009A	37011A	37007A	37009A
Cepillo de nilón para alfombras	-----	-----	-----	-----	-----	51498A	51701A
Portadisco de alta velocidad	-----	-----	-----	-----	-----	-----	-----
Portadisco para discos de arenado	-----	-----	-----	-----	-----	450214	460215
Tynex cubierto de abrasivo	-----	-----	51443A	51445A	51446A	51443A	51445A
Cepillo de alambre de acero	410963	410984	410963	410984	480924	410963	410984
Cepillo para fregar alfombras (Capture)	-----	-----	-----	-----	-----	-----	11405A
Conjunto de disco de amolar	-----	-----	-----	-----	-----	450212	500212
Faldón de protección contra el polvo	10087A	10088A	10087A	10088A	10089A	10087A	10088A

Modelo C2K	2000	160HS	180HS	200HS	1600DS	2000DS
Número de código	01201A	01202A	01203A	01204A	01205A	01206A
Conjunto de depósito de solución	50026A	50026A	50026A	50026A	50026A	50026A
Conjunto del vaporizador	-----	440570	440570	440570	440570	440570
Juego de pesas	10086A	-----	-----	-----	10086A	10086A
Cepillo de polipropileno para fregar	51707A	51704A	51706A	51707A	51704A	51707A
Portadisco con sujeción Standard	50866A	50864A	50865A	50866A	50864A	50866A
Portadisco con sujeción Perma Grip	53156A	53159A	53157A	53156A	53159A	53156A
Portadisco con sujeción Super Grip	37011A	37007A	37009A	37011A	37007A	37011A
Cepillo de nilón para alfombras	-----	-----	-----	-----	-----	-----
Portadisco de alta velocidad	-----	53154A	53153A	17518A	53154A	17518A
Portadisco para discos de arenado	-----	-----	-----	-----	-----	-----
Tynex cubierto de abrasivo	51446A	-----	-----	-----	-----	-----
Cepillo de alambre de acero	480924	-----	-----	-----	-----	-----
Cepillo para fregar alfombras (Capture)	11406A	-----	-----	-----	-----	-----
Conjunto de disco de amolar	-----	-----	-----	-----	-----	-----
Faldón de protección contra el polvo	10089A	10087A	10088A	10089A	10087A	10089A

**⚠ AVISO: Utilice únicamente las escobillas y los accesorios suministrados por el fabricante.**

## ACCESSOIRES

Les accessoires suivants sont disponibles:

1. Brosses pour cirer et polir
2. Brosses de récurage, avec brins en fibres naturelles ou synthétiques.
3. Brosses avec brins en acier
4. Porte-disques synthétiques
5. Disques synthétiques pour le polissage, le récurage, le décapage et le lustrage au tampon.
6. Brosses avec dos en métal ou en bois et avec gouttières pour la dispersion de solution.
7. Réservoir de solution
8. Disques de ponçage
9. Kit d'accessoires pour le lustrage par pulvérisation au tampon.

Modèle C2K	16	18	160	180	200	1600	1800
Numéro de code	01194A	01195A	01196A	01197A	01198A	01199A	01200A
Ensemble de réservoir de solution	50026A	50026A	50026A	50026A	50026A	50026A	50026A
Ensemble du vaporisateur	-----	-----	-----	-----	-----	-----	-----
Poids du Kit	-----	-----	-----	-----	-----	10086A	10086A
Brosse de récurage en polypropylène	51704A	51706A	51704A	51706A	51707A	51704A	51706A
Ensemble porte-disque avec fixation Standard	50864A	50865A	50864A	50865A	50866A	50864A	50865A
Ensemble porte-disque avec fixation Perma Grip	53159A	53157A	53159A	53157A	53156A	53159A	53157A
Ensemble porte-disque avec fixation Super Grip	37007A	37009A	37007A	37009A	37011A	37007A	37009A
Brosse nylon pour tapis	-----	-----	-----	-----	-----	51498A	51701A
Porte-disque grande vitesse	-----	-----	-----	-----	-----	-----	-----
Disque d'abrasif	-----	-----	-----	-----	-----	450214	460215
Nylon Tynex revêtu d'abrasif	-----	-----	51443A	51445A	51446A	51443A	51445A
Brosse brins d'acier	410963	410984	410963	410984	480924	410963	410984
Brosse de récurage Capture pour tapis	-----	-----	-----	-----	-----	-----	11405A
Ensemble de meulage	-----	-----	-----	-----	-----	450212	500212
Tablier à poussière	10087A	10088A	10087A	10088A	10089A	10087A	10088A

Modèle C2K	2000	160HS	180HS	200HS	1600DS	2000DS
Numéro de code	01201A	01202A	01203A	01204A	01205A	01206A
Ensemble de réservoir de solution	50026A	50026A	50026A	50026A	50026A	50026A
Ensemble du vaporisateur	-----	440570	440570	440570	440570	440570
Poids du Kit	10086A	-----	-----	-----	10086A	10086A
Brosse de récurage en polypropylène	51707A	51704A	51706A	51707A	51704A	51707A
Ensemble porte-disque avec fixation Standard	50866A	50864A	50865A	50866A	50864A	50866A
Ensemble porte-disque avec fixation Perma Grip	53156A	53159A	53157A	53156A	53159A	53156A
Ensemble porte-disque avec fixation Super Grip	37011A	37007A	37009A	37011A	37007A	37011A
Brosse nylon pour tapis	-----	-----	-----	-----	-----	-----
Porte-disque grande vitesse	-----	53154A	53153A	17518A	53154A	17518A
Disque d'abrasif	-----	-----	-----	-----	-----	-----
Nylon Tynex revêtu d'abrasif	51446A	-----	-----	-----	-----	-----
Brosse brins d'acier	480924	-----	-----	-----	-----	-----
Brosse de récurage Capture pour tapis	11406A	-----	-----	-----	-----	-----
Ensemble de meulage	-----	-----	-----	-----	-----	-----
Tablier à poussière	10089A	10087A	10088A	10089A	10087A	10089A

 **AVERTISSEMENT: N'utiliser que les brosses et accessoires fournis par le fabricant.**

## Machine Specifications

Model	C2K-16	C2K-18
Code Number	01194A	01195A
Voltage (Volts)	120	120
Frequency (Hz)	60	60
Current (Amps)	12	12
Power (hp)	0.75	0.75
Brush Diameter (inches)	16	18
Block Diameter (inches)	14	16
Brush Speed (rpm)	175	175
Cord Length (feet)	50	50
Weight (pounds)	88	89

Model	C2K-160	C2K-180	C2K-200	C2K-160HS	C2K-180HS	C2K-200HS
Code Number	01196A	01197A	01198A	01202A	01203A	01204A
Voltage (Volts)	120	120	120	120	120	120
Frequency (Hz)	60	60	60	60	60	60
Current (Amps)	14	14	14	14	14	14
Power (hp)	1	1	1	1	1	1
Brush Diameter (inches)	16	18	20	16	18	20
Block Diameter (inches)	14	16	18	14	16	18
Brush Speed (rpm)	175	175	175	290	290	290
Cord Length (feet)	50	50	50	50	50	50
Weight (pounds)	88	89	91	88	89	91

Model	C2K-1600	C2K-1800	C2K-2000	C2K-1600DS	C2K-2000DS
Code Number	01199A	01200A	01201A	01205A	01206A
Voltage (Volts)	120	120	120	120	120
Frequency (Hz)	60	60	60	60	60
Current (Amps)	15	15	15	15	15
Power (hp)	1.5	1.5	1.5	1.5	1.5
Brush Diameter (inches)	16	18	20	16	20
Block Diameter (inches)	14	16	18	14	18
Brush Speed (rpm)	175	175	175	180/320	180/320
Cord Length (feet)	50	50	50	50	50
Weight	89	90	92	81	84

## Especificaciones de la pulidora C2K

Modelo	C2K-16	C2K-18
Número de código	01194A	01195A
Tensión (V)	120	120
Frecuencia (Hz)	60	60
Corriente (A)	12	12
Potencia (hp)	0.75	0.75
Diámetro del cepillo (pulgadas)	16	18
Diámetro del bloque (pulgadas)	14	16
Velocidad del cepillo (rpm)	175	175
Longitud del cable de añadido (pies)	50	50
Peso (libras)	88	89

Modelo	C2K-160	C2K-180	C2K-200	C2K-160HS	C2K-180HS	C2K-200HS
Número de código	01196A	01197A	01198A	01202A	01203A	01204A
Tensión (V)	120	120	120	120	120	120
Frecuencia (Hz)	60	60	60	60	60	60
Corriente (A)	14	14	14	14	14	14
Potencia (hp)	1	1	1	1	1	1
Diámetro del cepillo (pulgadas)	16	18	20	16	18	20
Diámetro del bloque (pulgadas)	14	16	18	14	16	18
Velocidad del cepillo (rpm)	175	175	175	290	290	290
Longitud del cable de añadido (pies)	50	50	50	50	50	50
Peso (libras)	88	89	91	88	89	91

Model	C2K-1600	C2K-1800	C2K-2000	C2K-1600HD	C2K-2000DS
Número de código	01199A	01200A	01201A	01205A	01206A
Tensión (V)	120	120	120	120	120
Frecuencia (Hz)	60	60	60	60	60
Corriente (A)	15	15	15	15	15
Potencia (hp)	1.5	1.5	1.5	1.5	1.5
Diámetro del cepillo (pulgadas)	16	18	20	16	20
Diámetro del bloque (pulgadas)	14	16	18	14	18
Velocidad del cepillo (rpm)	175	175	175	180/320	180/320
Longitud del cable de añadido (pies)	50	50	50	50	50
Peso (libras)	89	90	92	81	84

## Spécifications de la cireuse de série C2K

Modèle	C2K-16	C2K-18
Numéro de code	01194A	01195A
Tension (volts)	120	120
Fréquence (Hz)	60	60
Courant (Amps)	12	12
Puissance (hp)	0.75	0.75
Diamètre de brosse (pouces)	16	18
Diamètre du bloc (pouces)	14	16
Vitesse de brosse (rpm)	175	175
Longueur du cordon (pieds)	50	50
Poids (livres)	88	89

Modèle	C2K-160	C2K-180	C2K-200	C2K-160HS	C2K-180HS	C2K-200HS
Numéro de code	01196A	01197A	01198A	01202A	01203A	01204A
Tension (volts)	120	120	120	120	120	120
Fréquence (Hz)	60	60	60	60	60	60
Courant (Amps)	14	14	14	14	14	14
Puissance (hp)	1	1	1	1	1	1
Diamètre de brosse (pouces)	16	18	20	16	18	20
Diamètre du bloc (pouces)	14	16	18	14	16	18
Vitesse de brosse (rpm)	175	175	175	290	290	290
Longueur du cordon (pieds)	50	50	50	50	50	50
Poids (livres)	88	89	91	88	89	91

Modèle	C2K-1600	C2K-1800	C2K-2000	C2K-1600DS	C2K-2000DS
Numéro de code	01199A	01200A	01201A	01205A	01206A
Tension (volts)	120	120	120	120	120
Fréquence (Hz)	60	60	60	60	60
Courant (Amps)	15	15	15	15	15
Puissance (hp)	1.5	1.5	1.5	1.5	1.5
Diamètre de brosse (pouces)	16	18	20	16	20
Diamètre du bloc (pouces)	14	16	18	14	18
Vitesse de brosse (rpm)	175	175	175	180/320	180/320
Longueur du cordon (pieds)	50	50	50	50	50
Poids (livres)	89	90	92	81	84



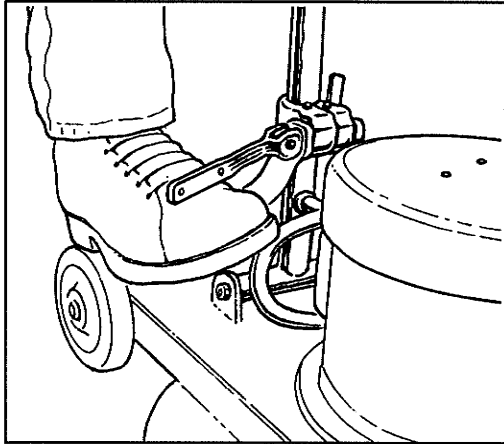

Figure 1

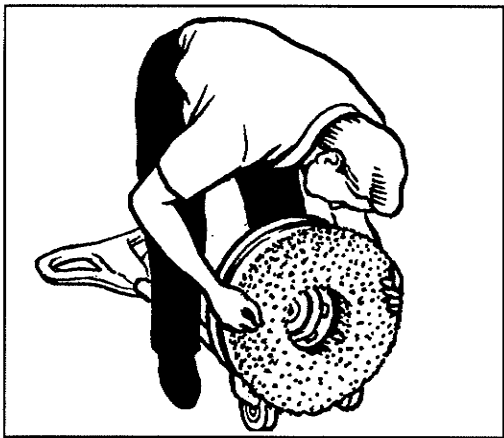

Figure 2

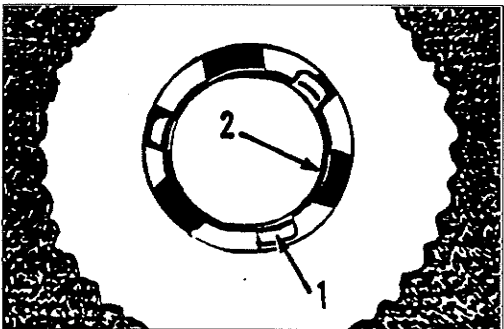

Figure 3

1. The lugs.
2. The drive adapter openings.

- 
1. Espigas
  2. Aberturas del acoplamiento

- 
1. Ergots
  2. Ouvertures de l'accouplement

## HOW TO PREPARE THE MACHINE FOR OPERATION

**⚠ WARNING:** Always remove the electrical plug from the electrical outlet before installing or changing the pad or brush.

### How To Install The Brush Or Pad Driver

To install the brush or pad driver, follow this procedure:

1. Put the handle in the vertical position.
2. To lock the handle, push the locking lever down. See figure 1.
3. Tilt the machine backward until the handle is on the floor. See figure 2.
4. Put one foot on each side of the machine. See figure 2.
5. Align the lugs (1) on the locking plate into the pad driver adapter openings (2). See figure 3.
6. To lock the brush or pad into position, turn the brush or pad driver clockwise.
7. Turn the brush or pad counterclockwise to unlock and remove the brush.
8. Lift the machine to the vertical position.

**NOTE:** To prevent damage to the brush or pad driver, remove the accessory while not in use. Keep the brush in a cool, dry place.

### How To Adjust The Handle

To adjust the handle, follow this procedure:

1. The locking lever is on the lower part of the handle tube. Use your foot to lift the lever. See figure 1.
2. Lower the handle to the best operating position.

**NOTE:** For the best operating position, keep your back straight, bend only your arms.

3. Using your foot, push the locking lever down.
4. Hold the handle against your body for the best control.

## PREPARACION DE LA MAQUINA PARA TRABAJAR

 **AVISO:** Desconecte siempre el enchufe de la caja de enchufe conectada con la red antes de instalar o cambiar el disco o el cepillo.

Cómo instalar el cepillo o el portadisco

Para instalar una cabeza de cepillo o un portadisco, sigue este procedimiento :

1. Coloque la tobera en posición vertical.
2. Para bloquear la tobera, empuje la palanca de bloqueo (hacia abajo). (Véase fig. 1)
3. Vuelque la máquina hacia atrás hasta que la tobera toca el suelo. (Véase fig. 2).
4. "Cabalgando" sobre la máquina (Véase fig. 2)
5. Inserte el arrastre central del cepillo sobre el acoplamiento de la máquina. (Véase fig. 3)
6. Fije el cepillo o el disco girando en el sentido de las agujas del reloj.
7. Para quitar el cepillo o el disco, desbloquee el accesorio girando en el sentido contrario de las agujas del reloj, pues sáquelo.
8. Coloque de nuevo la máquina en posición vertical.

**NOTA:** Para evitar causar daños al cepillo o al portadisco, quite el accesorio cuando guarda la máquina. Guarde la máquina en un sitio seco y fresco.

### Reglaje de la tobera

Para reglar la tobera, sigue este procedimiento :

1. La palanca de bloqueo se encuentra en la parte inferior del montante de la tobera. Levante la palanca con el pie. (Véase fig. 1).
2. Baje la tobera en la posición de trabajo la más confortable.

**NOTA:** La mejor posición de trabajo es cuando la espalda está recta y los brazos son doblados.

3. Con el pie baje la palanca de bloqueo.
4. Para controlar mejor la máquina, tenga el mango cerca del cuerpo mientras trabaja.

## PREPARATION DE LA MACHINE AVANT LA MISE EN SERVICE

 **AVERTISSEMENT:** Débranchez toujours la fiche de la prise réseau avant d'installer ou de changer le disque ou la brosse.

Comment installer la brosse ou le porte-disque

Pour placer une tête de brosse ou un porte-disque, procéder comme suit:

1. Placer le timon en position verticale.
2. Pour verrouiller le timon, presser le levier de verrouillage (vers le bas) (Voir fig.1)
3. Incliner la machine vers l'arrière jusqu'à ce que le timon touche le sol. (Voir fig.2)
4. En "chevauchant" la machine (Voir fig. 2)
5. Insérer l'entraînement central de la brosse sur l'accouplement de la machine. (Voir fig. 3)
6. Fixer la brosse ou le disque par pivotement dans le sens horlogique.
7. Pour déposer la brosse ou le disque, débloquent l'accessoire par pivotement dans le sens anti-horlogique, puis le retirer.
8. Redresser la machine en position verticale.

**NOTE:** Pour éviter d'endommager la brosse ou le porte-disque, enlever l'accessoire lorsque vous entreposez la machine. Entreposer la machine dans un endroit sec et frais.

### Réglage du timon

Pour régler le timon, procéder comme suit :

1. Le levier de verrouillage se trouve sur la partie inférieure du montant du timon. Relever le levier avec le pied (Voir fig.1).
2. Abaisser le timon dans la position de travail la plus confortable.

**NOTE** La meilleure position de travail est celle où le dos est bien droit et où seuls les bras sont fléchis.

3. Avec le pied, abaisser le levier de verrouillage.
4. Pour mieux contrôler la machine, tenir la poignée près du corps pendant le travail.

## 120 VOLT MACHINES

### Instructions for connection to the power supply and the electrical ground.

This product must be grounded. If it should malfunction or breakdown, grounding provides a path of least resistance for electric current to reduce the risk of electrical shock. This product is equipped with a cord having an equipment-grounding conductor and grounding plug. The plug must be inserted into an appropriate outlet that is properly installed and grounded in accordance with all local codes and ordinances.

**⚠ WARNING:** Improper connection of the equipment-grounding conductor can result in a risk of electric shock. Check with a qualified electrician or service person if you are in doubt as to whether the outlet is properly grounded. Do not modify the plug provided with the product - if it will not fit the outlet, have a proper outlet installed by a qualified electrician.

This product is for use on a nominal 120 volt circuit and has a grounding attachment plug that looks like the plug illustrated in Fig. 4. Make sure that the product is connected to an outlet having the same configuration as the plug. No adaptor should be used with this product.

**⚠ WARNING:** To prevent possible electric shock, protect the machine from rain. Keep the machine in a dry building.

**⚠ WARNING:** To prevent possible electric shock, always use a 3-wire electrical system connected to the electrical ground. For maximum protection against electrical shock, use a circuit that is protected by a ground fault circuit interrupter. Consult your electrical contractor.

**⚠ WARNING:** Do not cut, remove or break the ground pin. If the outlet does not fit the plug, consult your electrical contractor.

**⚠ WARNING:** Have worn, cut or damaged cords replaced by an authorized service person.

### EXTENSION CORDS

Use only an approved extension cord with three conductors, a plug with three terminals, and a connector body with three holes. The machine has a power cord with wire size 14 AWG (AWG means American Wire Gauge).

**⚠ WARNING:** If you use an extension cord, use an extension cord with minimum wire size 12 AWG. Do not use an extension cord longer than 50 feet. Do not join two extension cords.

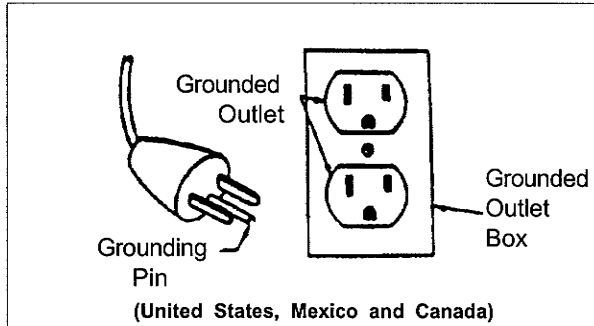

Figure 4

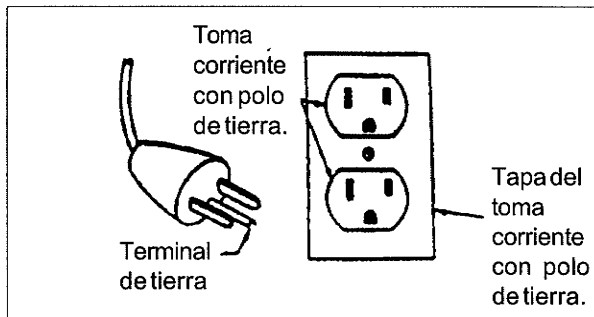

Figure 4a

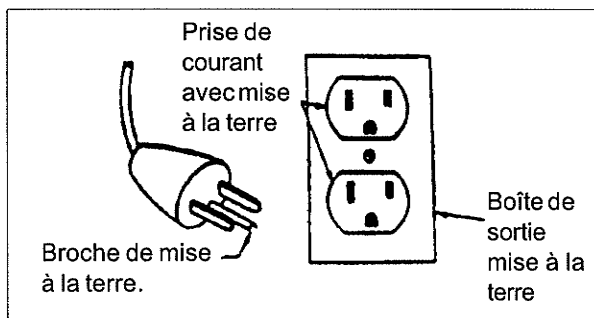

Figure 4b

## MAQUINAS 120 V.

### INSTRUCCIONES PARA LA CONEXION ELECTRICA DE LA MAQUINA

La máquina debe ser puesta a tierra. En caso de mal funcionamiento o de avería, el hilo de tierra es un camino de menor resistencia que permite el paso de corriente ; por lo cual se reduce el riesgo de choque eléctrico. La máquina tiene un cable de alimentación con tres conductores y un enchufe con tres clavijas de las cuales una está puesta a tierra. El enchufe sólo puede ser conectado con una caja de enchufe reglamentaria, puesta a tierra con todas las reglas del arte y conforme a los reglamentos locales.

**⚠ AVISO :** Una conexión incorrecta del conductor de puesta a tierra puede causar un choque eléctrico. Acuda a un técnico autorizado o a un electricista si tiene alguna duda acerca de la puesta a tierra correcta de la caja de enchufe conectada con la red. Nunca modifique el enchufe suministrado con la máquina. Si no encaja el enchufe en la caja de enchufe conectada con la red, haga instalar una caja de enchufe adecuada por un electricista autorizado.

Esta máquina debe funcionar en un circuito de potencia nominal de 120 V. Tiene un enchufe con una clavija de puesta a tierra semejante al enchufe reproducido en la figura 4a. Compruebe que la máquina esté conectada con una caja de enchufe que tiene la configuración adecuada. No utilice ningún adaptador.

**⚠ AVISO:** Para evitar el peligro de choque eléctrico, proteja la máquina de la lluvia. Guárdela en un local seco.

**⚠ AVISO:** Para evitar el peligro de electrocución, conecte la máquina con una red que tiene tres conductores, está puesta a tierra y tiene un diferencial. Si tiene alguna duda, diríjase a un electricista autorizado.

**⚠ AVISO:** Nunca rompa, quite o corte la clavija de puesta a tierra. Si la caja de enchufe no corresponde al enchufe, acuda a un electricista autorizado.

**⚠ AVISO:** Si el cable de alimentación está desgastado, dañado o cortado, hágalo cambiar inmediatamente por un técnico autorizado.

### AÑADIDOS

Use sólo un añadido con tres conductores, de los cuales uno está puesto a tierra, y con un enchufe con tres clavijas y un conector con tres aberturas. La máquina tiene un cable de alimentación de 14 AWG (American Wire Gauge) (Calibre estadounidense para alambre) de sección.

**⚠ ¡ AVISO !** Use un añadido de cable de 12 AWG de sección. No use ningún añadido de más de 50 pies de largo. Nunca conecte dos añadidos.

## MACHINES 120 V.

### INSTRUCTIONS POUR LE RACCORDEMENT ELECTRIQUE

Cette machine doit être mise à la terre. En cas de dysfonctionnement ou de panne, le fil de terre constitue un chemin de moindre résistance qui permet le passage du courant, réduisant ainsi le risque de choc électrique. La machine est munie d'un câble d'alimentation à trois conducteurs et d'une fiche à trois broches, dont une sert à la mise à la terre. La fiche ne peut être branchée que dans une prise réglementaire, reliée à la terre selon les règles de l'art et qui satisfait à tous les règlements locaux.

**⚠ AVERTISSEMENT:** Une mise à la terre incorrecte peut provoquer un choc électrique. Si vous avez le moindre doute quant à la mise à la terre de votre prise réseau, faites-la vérifier par un électricien ou un technicien agréé. Ne modifiez jamais la fiche fournie avec la machine. Si la fiche ne rentre pas dans la prise réseau dont vous disposez, faites installer une prise adéquate par un électricien agréé.

Cette machine doit être utilisée sur un circuit d'une puissance nominale de 120 V. Elle est munie d'une fiche avec broche de mise à la terre semblable à celle illustrée à la figure 4b. Vérifiez que la prise à laquelle la machine doit être raccordée présente une configuration correspondant à la fiche. N'utilisez pas d'adaptateur.

**⚠ AVERTISSEMENT:** Pour éviter tout risque de choc électrique, protégez la machine de la pluie. Entreposez-la dans un local sec.

**⚠ AVERTISSEMENT:** Pour éviter tout risque d'électrocution, connectez la machine sur un réseau à trois conducteurs, relié à la terre et muni d'un différentiel. En cas de doute, adressez-vous à un électricien agréé.

**⚠ AVERTISSEMENT:** Ne jamais casser, enlever ou couper la broche de mise à la terre. Si la prise ne correspond pas à la fiche, faire appel à un électricien agréé.

**⚠ AVERTISSEMENT:** Si le câble d'alimentation est usé, endommagé ou entaillé, faites-le remplacer immédiatement par un technicien agréé.

### ALLONGES

N'utiliser qu'une allonge à trois conducteurs, dont un de mise à la terre, munie d'une fiche à trois broches et d'un connecteur à trois orifices. La machine est équipée d'un câble d'alimentation de 14 AWG (American Wire Gauge) de section.

**⚠ ! AVERTISSEMENT !** Utilisez un câble de rallonge d'une section de 12 AWG. N'utilisez pas de rallonge d'une longueur supérieure à 50 pieds. Ne raccordez jamais deux rallonges.

---

## HOW TO OPERATE THE MACHINE

### How To Start/Stop The Machine

**⚠ WARNING:** Never start a polisher when the handle is in the vertical position.

The following step applies to the C2K-1600DS and C2K-2000DS only: Select high or low speed with the switch located on the motor cover. Moving the switch lever up selects high speed. Moving the switch lever down selects low speed.

The following steps apply to all C2K series:

The switch to start and stop the machine is activated by the interlock switch (1) and the levers (2) under the handle grips. See figure 5.

To start the machine, follow this procedure:

1. Lower the handle
2. Lock the handle in the best position for operation.

**NOTE:** Make sure you hold the handle with both hands.

3. Push the interlock switch (1), and apply pressure to the levers (2). See figure 5.

### How To Control The Machine

**NOTE:** Make sure you hold the handle with both hands.

The side to side movement of the machine is controlled by raising the handle and pressing down on the handle. To move the machine to the left, press down on the handle slightly. To move the machine to the right, raise the handle slightly.

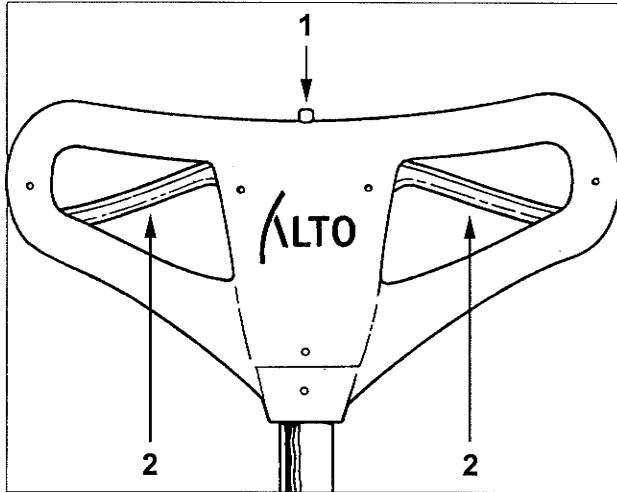

Figure 5

---

## MAINTENANCE

**⚠ WARNING:** Maintenance must be done by authorized personnel only.

### Maintenance Instructions

Return the machine to a Clarke Technology Authorized Service Location every 12 months for maintenance inspections.

## FUNCIONAMIENTO DE LA MAQUINA

Arranque y parada

**⚠ AVISO:** Nunca arranque una pulidora cuando la tobera está en posición vertical.

Sólo para el modelo C2K-1600DS, C2K-2000DS:  
Seleccione la velocidad (alta o moderada - high o low) por medio del interruptor situado en la tapa del motor. Velocidad alta : la palanca está empujada hacia arriba. Velocidad moderada : la palanca está empujada hacia abajo.

Los siguientes pasos se aplican a toda la serie C2K: El interruptor de arranque/parada se opera empujando el botón de cierre de seguridad (1) y usando las palancas (2) situadas debajo del mango de mando (Véase fig. 5).

Para arrancar la máquina, siga este procedimiento :

1. Baje la tobera.
2. Bloquee la tobera en la posición de trabajo la más confortable para el operador.

**NOTA :** Siempre tenga el mango con ambas manos.

3. Empuje el botón de cierre (1) y presione con las manos sobre las palancas (2). (Véase fig. 5).

## DOMINIO DE LA MAQUINA

**NOTA :** Siempre tenga el mango con ambas manos.

Para ir de un lado al otro, levante o baje lentamente la tobera de la máquina.  
Para dirigir la máquina hacia la izquierda, presione la tobera.  
Para dirigir la máquina hacia la derecha, levante despacio la tobera.

## MANTENIMIENTO

**⚠ AVISO:** El mantenimiento debe ser efectuado por un técnico autorizado.

Instrucciones para el mantenimiento  
Cada 12 meses, la máquina debe ser mandada a un centro técnico autorizado Clarke Technology para ser comprobada.

## MISE EN SERVICE DE LA MACHINE

Mise en Marche et Arrêt

**⚠ AVERTISSEMENT:** Ne jamais mettre une polisseuse en marche lorsque le timon est en position verticale.

Uniquement pour le modèle C2K-1600DS, C2K-2000DS :

Sélectionnez la vitesse (élevée ou modérée - high ou low ) au moyen de l'interrupteur situé sur le couvercle du moteur. Vitesse élevée : levier poussé vers le haut. Vitesse modérée : levier poussé vers le bas.

Les étapes suivantes s'appliquent à tous les modèles de la série C2K:

L'interrupteur de marche/arrêt est activé par pression sur le bouton de verrouillage de sécurité (1) et par les leviers (2) situés sous la poignée de commande (Voir fig. 5).

Pour mettre la machine en marche, procéder comme suit :

1. Abaisser le timon
2. Verrouiller le timon dans la position de travail la plus confortable pour l'opérateur.

**NOTE :** Il faut toujours tenir la poignée des deux mains.

3. Pousser sur le bouton de verrouillage (1) et appliquer une pression des mains sur les leviers (2). (Voir fig. 5).

## MAITRISE DE LA MACHINE

**NOTE :** Il faut toujours tenir la poignée des deux mains.

Pour aller d'un côté à l'autre, lever ou abaisser lentement le timon de la machine.  
Pour faire aller la machine vers la gauche, appliquer une pression sur le timon.  
Pour faire aller la machine vers la droite, relever légèrement le timon.

## ENTRETIEN

**⚠ AVERTISSEMENT:** L'entretien doit toujours être effectué par un technicien agréé.

Instructions pour l'entretien  
Tous les 12 mois, la machine doit être renvoyée dans un centre technique agréé Clarke Technology , pour vérification.





**C2K Series**  
**120V**  
Section II  
**Parts and Service Manual**

(70152A)

---

---

## MAINTENANCE

 **WARNING: Maintenance must be done by authorized personnel only.**

 **CAUTION: Keep all adjustments according to specifications.**

### Maintenance Instructions

Return the machine to a Clarke Technology Authorized Service Location every 12 months for maintenance inspections.

### Switches

 **WARNING: All electrical repairs must be done by authorized personnel only. The machine must be tested after electrical repairs to make sure it is safe to operate. Disconnect the electrical plug from the electrical outlet before doing any electrical repairs.**

The start and stop switch has an interlock which prevents the contacts from being closed. If any part of the switch is not operating, replace the part. If any part of the electrical system of the machine is not operating or is damaged, replace the part. Make sure all connections are tight. Return the machine to the Clarke Technology Service Branch or a Clarke Technology Authorized Service Center for electrical repairs or testing.

### Maintenance Of The Motor

Induction type motors do not require motor brushes. C2K-1600DS and C2K-2000DS require motor brushes.

If repairs to the gear unit or motor are needed, do not disassemble the gears and motor. Return the machine to the nearest Clarke Technology Service Branch or Clarke Technology Authorized Service Center.

For safe operation, and longer life to your Clarke Technology product, use only Clarke Technology parts.

**NOTE: The grease (503802) for the gear box needs to be changed every year. The C2K-1600, C2K-1600DS, C2K-1800, C2K-2000 and C2K-2000DS require 8 oz. of grease. All other C2K series require 9 oz. of grease.**

## MANTENIMIENTO

 **AVISO:** El mantenimiento debe ser efectuado por un técnico autorizado.

 **PRUDENCIA:** Todos los reglajes deben ser realizados conforme a las indicaciones descritas en este libro.

### Instrucciones para el mantenimiento

Cada 12 meses, la máquina debe ser mandada a un centro técnico autorizado CLARKE TECHNOLOGY para ser comprobada.

### Interruptores

 **AVISO:** Todas las reparaciones eléctricas deben ser efectuadas por técnicos autorizados. Después de cada reparación, hay que comprobar el aislamiento eléctrico. Desconecte siempre el enchufe del cable de alimentación antes de realizar cualquier reparación eléctrica.

El interruptor arranque/parada tiene un seguro que impide a los contactos que se cierren. Si un componente del interruptor no funciona, cambie este componente. Si una pieza del sistema eléctrico de la máquina no funciona o está dañada, cambie la pieza. Compruebe que todas las conexiones están bien fijadas. Mande la máquina a un centro técnico autorizado CLARKE TECHNOLOGY para cualquier reparación o comprobación del sistema eléctrico.

### Mantenimiento del motor

Los motores de inducción no requieren la utilización de escobillas. C2K-1600DS y C2K-2000DS requieren escobillas.

Si tiene que efectuar reparaciones al sistema de accionamiento o al motor, no desmonte la máquina, mándela a un centro técnico autorizado CLARKE TECHNOLOGY.

Para alargar la longevidad de la máquina y garantizar su funcionamiento óptimo, use sólo recambios CLARKE TECHNOLOGY.

**NOTA:** La grasa del sistema de accionamiento (503802) debe ser cambiada cada año. Los modelos C2K-1600, C2K-1600DS, C2K-1800, C2K-2000 y C2K-2000DS necesitan 236 cm<sup>3</sup> de grasa. Todos los demás sistemas de accionamiento de la serie C2K necesitan 266cm<sup>3</sup> de grasa.

## ENTRETIEN

 **AVERTISSEMENT:** L'entretien doit toujours être effectué par un technicien agréé.

 **PRUDENCE:** Tous les réglages doivent être réalisés conformément aux indications figurant dans ce manuel.

### Instructions pour l'entretien

Tous les 12 mois, la machine doit être renvoyée dans un centre technique agréé CLARKE TECHNOLOGY, pour vérification.

### Interrupteurs

 **AVERTISSEMENT:** Toutes les réparations électriques doivent être effectuées par des techniciens agréés. Après toute réparation, l'isolation électrique doit être vérifiée. Débrancher toujours la fiche du câble d'alimentation avant de procéder à toute réparation électrique.

L'interrupteur marche/arrêt est muni d'une sécurité qui empêche les contacts de se refermer. Si un élément de l'interrupteur ne fonctionne pas, remplacer cet élément. Si une pièce du système électrique de la machine ne fonctionne pas ou est endommagée, remplacez la pièce. Vérifiez que toutes les connexions sont bien fixées. Renvoyez la machine dans un centre technique agréé CLARKE TECHNOLOGY pour toute réparation ou vérification du système électrique.

### Entretien du moteur

Les moteurs à induction ne nécessitent pas l'utilisation de balais. Les modèles C2K-1600DS et C2K-2000DS nécessitent des balais de moteur.

Si des réparations doivent être faites au système d'entraînement ou au moteur, ne pas démonter la machine mais la renvoyer dans un centre technique agréé CLARKE TECHNOLOGY.

Pour prolonger la vie de la machine et garantir son fonctionnement optimal, n'utilisez que des pièces de rechange CLARKE TECHNOLOGY.

**NOTE :** La graisse du système d'entraînement (503802) doit être changée chaque année. Les modèles C2K-1600, C2K-1600DS, C2K-1800, C2K-2000 et C2K-2000DS il faut 236 cm<sup>3</sup> de graisse. Tous les autres systèmes d'entraînement de la série C2K nécessitent 266cm<sup>3</sup> de graisse.

CLARKE TECHNOLOGY  
 C2K-16, C2K-18, C2K-160, C2K-180, C2K-200,  
 C2K-1600, C2K-1800, C2K-2000, C2K-160HS, C2K-180HS, C2K-200HS  
 Assembly Drawing 2/01

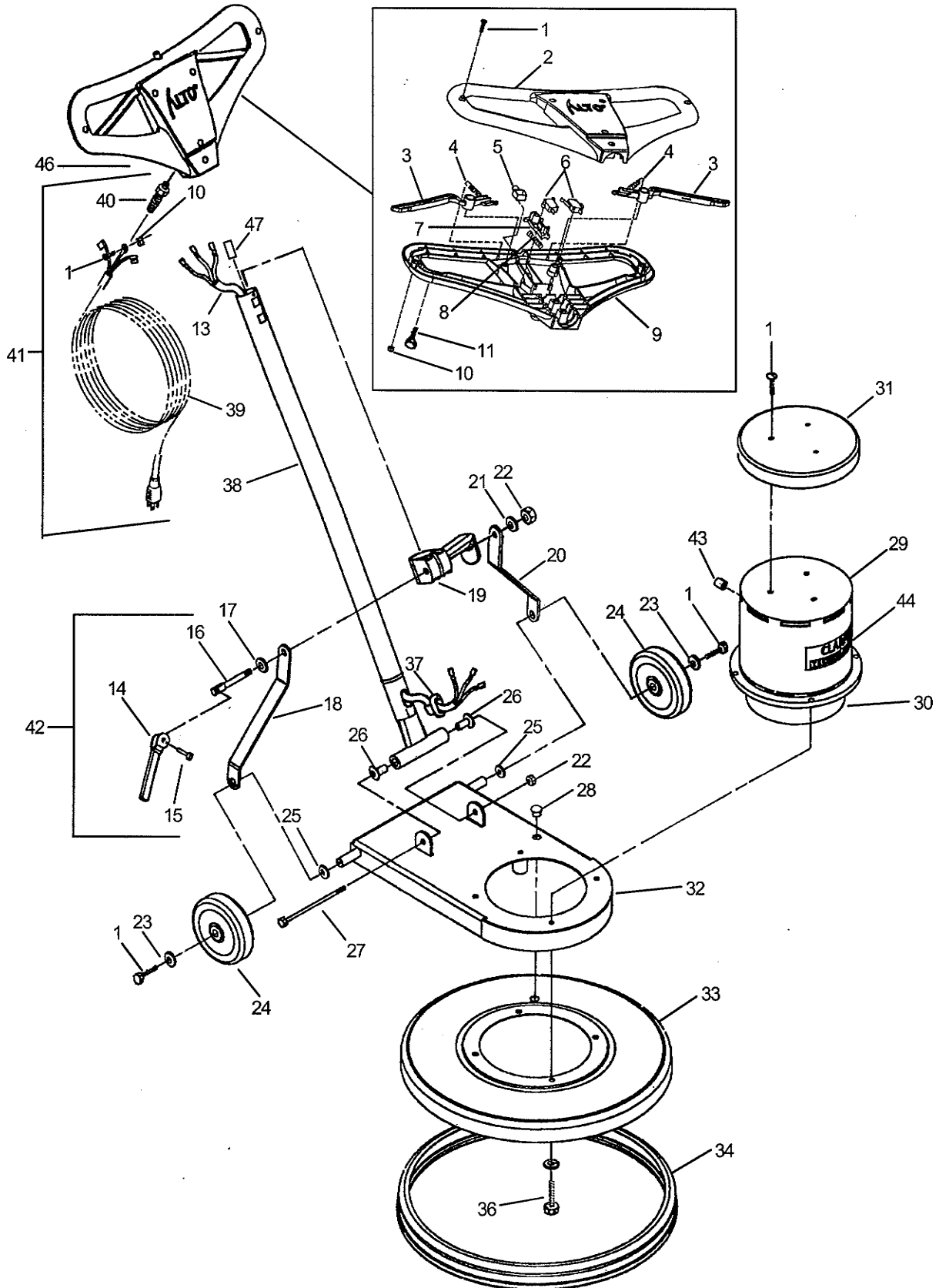

**CLARKETECHNOLOGY**  
**C2K-16, C2K-18, C2K-160, C2K-180, C2K-200,**  
**C2K-1600, C2K-1800, C2K-2000, C2K-160HS, C2K-180HS, C2K-200HS**  
**Assembly Drawing Parts List 2/01**

Ref.	Part No.	Description	Qty.
1	85383A	Screw, 10-32 x 3/4	10
2	50779A	Handle, Front	1
3	50798A	Lever, Switch	2
4	50820A	Spring, Extension	2
5	50806A	Button, Interlock	1
6	40109A	Switch	2
7	50799A	Interlock, Main	1
8	50821A	Spring, Compression	1
9	50780A	Handle, Rear	1
10	920722	Nut, 10-32 ESNA	7
11	962957	Screw	2
13	10092A	Cord, Interconnect	1
14	461404	Cam, Locking (included in 42)	1
15	925592	Roll Pin, 1/4 (included in 42)	1
16	441301	Bolt, Locking Cam (included in 42)	1
17	980349	Washer, Wear Cam	1
18	50791A	Arm Link, RH	1
19	50781A	Clamp, Handle	1
20	50792A	Arm Link, LH	1
21	980645	Washer, Flat 3/8	1
22	920342	Nut, 3/8 -16 ESNA	2
23	87035A	Washer, Fender #10 SS	2
24	50793A	Wheel, 5"	2
25	87050A	Washer, 5/8 Nylon	2
26	50794A	Bushing, Nylon	2
27	80087A	Screw, 3/8 -16 x 6	1
28	57120A	Plug, Button	1
29	50955A	Motor, 3/4 HP (16, 18)	1
30	44635A	Motor, 1 HP (160, 180, 200)	1
	50858B	Motor, 1.5 HP (1600)	1
	50858A	Motor, 1.5 HP (1800, 2000)	1
	54409A	Gearbox (16, 18, 160, 180, 200)	1
	52093A	Gearbox (160HS, 180HS, 200HS)	1
31	50851A	Gearbox (1600, 1800, 2000)	1
	50822A	Cover, Motor (16, 18, 160, 180, 200, 160HS, 180HS, 200HS)	1
32	50823A	Cover, Motor (1600, 1800, 2000)	1
	50790A	Frame, Main	1
33	50785A	Shield, Brush (16, 160, 1600)	1
	50786A	Shield, Brush (18, 180, 1800)	1
	50787A	Shield, Brush (200, 2000)	1
34	50782A	Bumper, (16, 160, 1600)	1
	50783A	Bumper, (18, 180, 1800)	1
	50784A	Bumper, (200, 2000)	1
	50784A	Bumper, (200, 2000)	1
36	85817A	Screw, 5/16-18 x 2 1/8	4
37	50796A	Bushing, Cord	1
38	50795A	Tube, Handle	1
40	50797A	Relief, Strain (included w/41)	1
41	10083A	Cord Assembly (includes 40)	1
42	441401	Cam Assembly (incl. 14, 15 & 16)	(1)
43	747553	Strain Relief	1
44	77378A	Label	1
45	980603	Lockwasher #10	1
46	170686	Lock nut (not illustrated)	1
47	50930A	Cord Retainer	1

Note: ♦ indicates a change has been made since last publication of this manual

CLARKETECHNOLOGY  
 C2K-1600DS and C2K-2000DS  
 Assembly Drawing 2/01

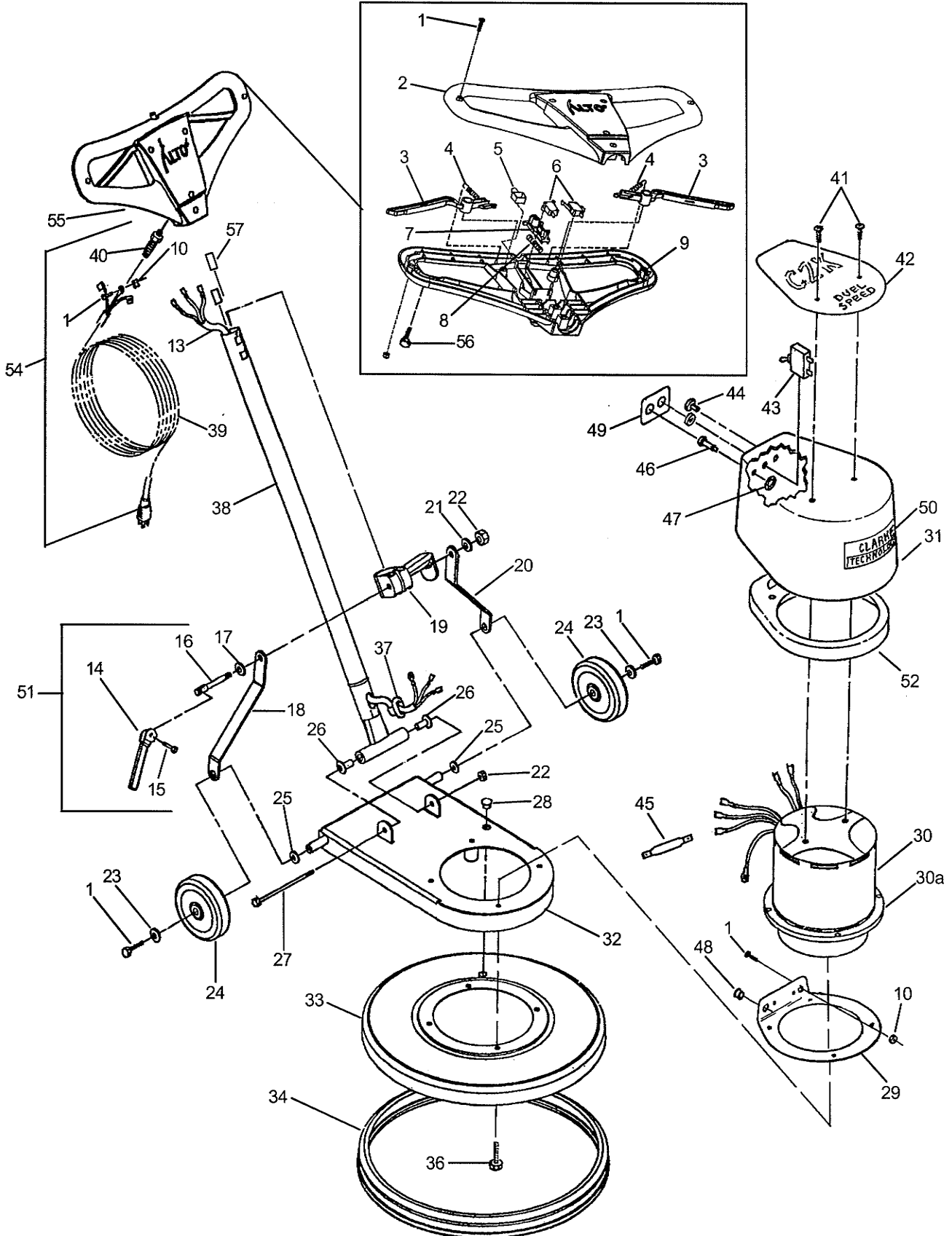

**CLARKETECHNOLOGY**  
**C2K-1600DS and C2K-2000DS**  
**Assembly Parts List 2/01**

Ref.	Part No.	Description	Qty.
1	85383A	Screw, 10-32 x 3/4	8
2	50779A	Handle, Front	1
3	50798A	Lever, Switch	2
4	50820A	Spring, Extension	2
5	50806A	Button, Interlock	1
6	40109A	Switch	2
7	50799A	Interlock, Main	1
8	50821A	Spring, Compression	1
9	50780A	Handle, Rear	1
10	920722	Nut, 10-32 ESNA	8
13	10084A	Cord, Interconnect	1
14	461404	Cam, Locking (Included in 51)	1
15	925592	Roll Pin, 1/4 (Included in 51)	1
16	441301	Bolt, Locking Cam (included in 51)	1
17	980349	Washer, Wear Cam	1
18	50791A	Arm Link, RH	1
19	50781A	Clamp, Handle	1
20	50792A	Arm Link, LH	1
21	980645	Washer, Flat 3/8	1
22	920342	Nut, 3/8 -16 ESNA	2
23	87035A	Washer, Fender #10 SS	2
24	50793A	Wheel, 5"	2
25	87050A	Washer, 5/8 Nylon	2
26	50794A	Bushing, Nylon	2
27	80087A	Screw, 3/8 -16 x 6	1
28	57120A	Plug, Button	1
29	50825A	Bracket	1
30	44651A	Motor/Gearbox	1
30a	63602A	Gearbox	(1)
31	50824A	Cover, Motor	1
32	50790A	Frame, Main	1
33	50785A	Shield, Brush (1600)	1
	50787A	Shield, Brush (2000)	1
34	50782A	Bumper, (1600)	1
	50784A	Bumper, (2000)	1
36	85817A	Screw, 5/16-18 x 2 1/8	4
37	50796A	Bushing, Cord	1
38	50795A	Tube, Handle	1
40	50797A	Relief, Strain (included w/54)	1
41	85517A	Screw	2
42	70151A	Label, Dual Speed	1
43	47402B◆	Switch SPDT	1
44	57165A◆	Plug, Nylon Hole	1
45	40181A◆	Insulated Jumper	1
46	34259A	Light	1
47	80201A	Clip	1
48	747553	Strain Relief	1
49	77200A	Label, (High-Low)	1
50	77378A	Label	1
51	441401	Cam Assembly (incl. 14, 15, & 16)	(1)
52	30605A	Baffle	1
54	10083A	Cord Assembly (includes 40)	1
55	170686◆	Locknut	1
56	962957	Screw	1
57	50930A	Cord Retainer	1

Note: ◆ indicates a change has been made since last publication of this manual

**CLARKETECHNOLOGY**  
**C2K-16, C2K-18, C2K-160, C2K-180, C2K-200, C2K-160HS, C2K-180HS and C2K-200HS**  
**120V - 60 Hz Motor Assembly Drawing & Parts List 9/99**

**Note: If your machine has motor #44635A refer to this drawing for service part replacement.**

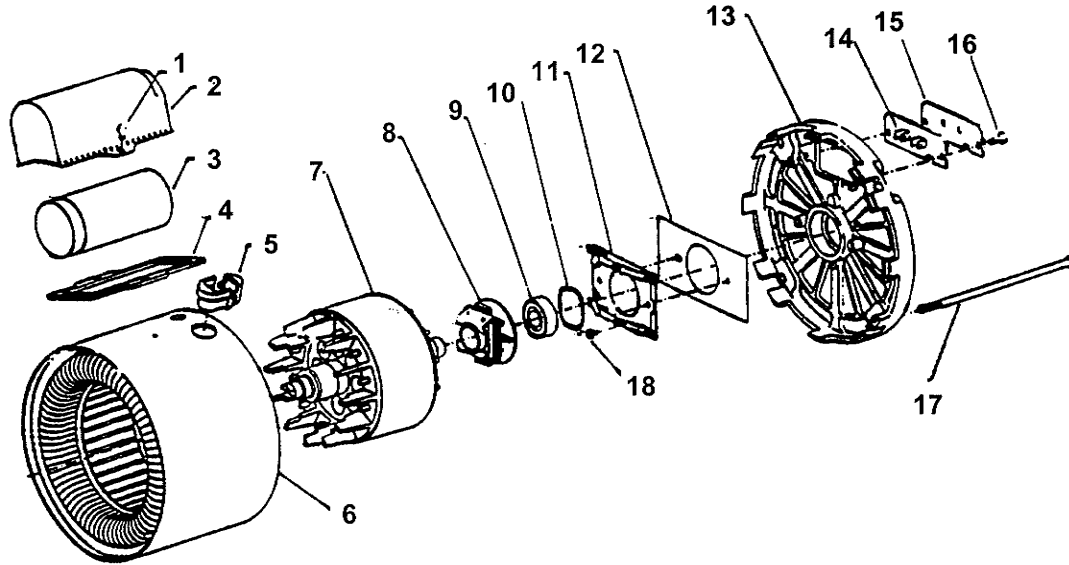

Ref.	Part No.	Description	Qty.	Ref.	Part No.	Description	Qty.
1	58030A	Screw #10-32 x.31 LG.	2	10	58673A	Wave Spring Washer	1
2	52018A	Capacitor Case	1	11	58032A	Stationary Switch	1
3	52019A	Start Capacitor	1	12	54713A	Stationary Switch Insulation	1
4	54330A	Gasket, Capacitor Case	1	13	53523A	Bracket Opp. Shaft End	1
5	737502	Strain Relief	1	14	58911A	Terminal Board Asm.	1
6	58028A	Stator Frame Asm	1	15	58912A	Terminal Board	1
7	50400A	Rotor and Shaft Assembly	1	16	58034A	Screw #10-32 x .31	2
8	58029A	Centrifugal Switch Asm.	1	17	50691A	Bolt, .250-28 x 6.75 LG	4
9	902550	203 Bearing	1	18	58031A	Screw, #8-32 x .38 LG	2

**120V Motor  
Electrical Schematic**

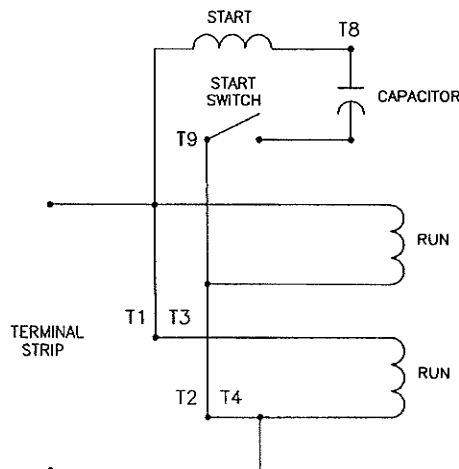

**CLARKETECHNOLOGY**  
**C2K-16, C2K-18, C2K-160, C2K-180 and C2K-200**  
**Gearbox Assembly Drawing & Parts List 2/01**

**Note:** If your machine has gearbox #54409A refer to this drawing for service part replacement.

**Note:** ♦ indicates a change has been made since last publication of this manual

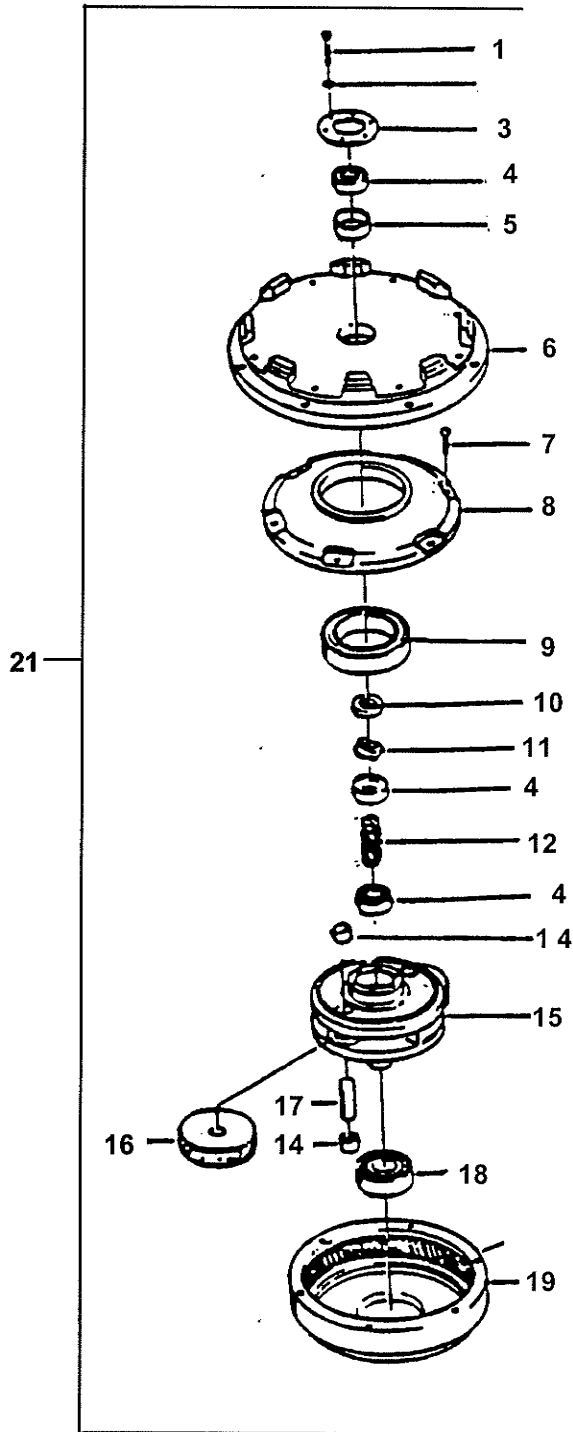

Ref.	Part No.	Description	Qty.
1	80141A ♦	Screw, Socket Hd. Cap	6
2			
3	56922A	Plate, Retainer	1
4	902606	Bearing	3
5	58513A	Spacer, Sleeve	1
6	53524A	Endshield	1
7	962794	Screw 10-24" x 1"	6
8	54858A	Cover, Housing	1
9	902736	Bearing	1
10	58314A	Retainer	1
11	442473	Coupling	1
12	58313A	Gear, Pinion	1
14	902737	Bearing, Needle	6
15	52020A	Cage	1
16	54408A	Gear, Idler	2
17	58312A	Shaft	2
18	902573	Bearing	1
19	54856A	Housing, Drive	1
20			
21	54409A	Gearbox Asm., Complete	(1)

**CLARKETECHNOLOGY**  
**C2K-160HS, C2K 180HS and C2K 200HS**  
**Gearbox Assembly Drawing & Parts List 2/00**

**Note:** If your machine has gearbox #50884A or #52093A refer to this drawing for service part replacement.

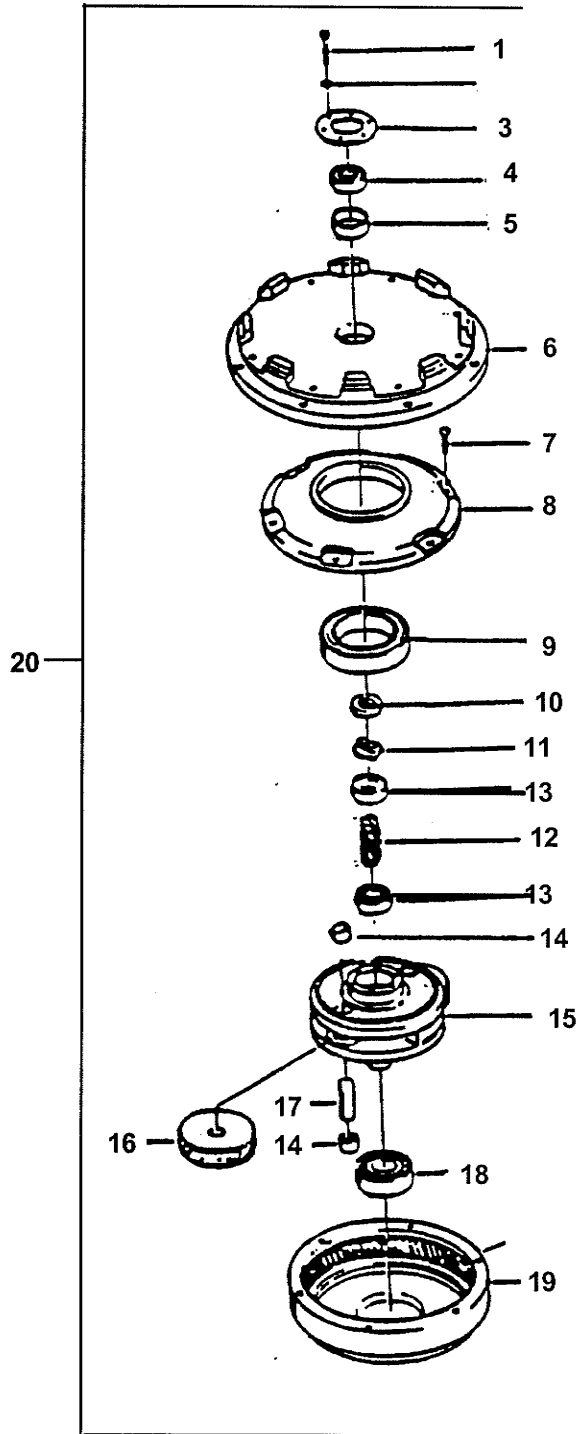

Note: ♦ indicates a change has been made since the last publication of this manual.

Ref.	Part No.	Description	50884A	52093A
			Qty.	Qty.
1	80141A♦	Screw, Socket Hd. Cap	6	6
2				
3	56922A	Plate, Retainer	1	1
4	902606	Bearing	1	1
5	58513A	Spacer, Sleeve	1	1
6	53524A	Endshield	1	1
7	962794	Screw 10-24" x 1"	6	6
8	54858A	Cover, Housing	1	1
9	902736	Bearing	1	1
10	58314A	Retainer	1	1
11	442473	Coupling	1	1
12	50887A	Gear, Pinion	1	-
	50854A	Gear, Pinion	-	1
13	902606	Bearing	-	2
14	902737	Bearing, Needle	4	4
15	50886A	Cage	1	-
	50855A	Cage	-	1
16	50888A	Gear, Idler	2	-
	50856A	Gear, Idler	-	2
17	58312A	Shaft	2	2
18	902573	Bearing	1	1
19	50857A	Housing, Drive	1	1
20	52093A	Gearbox Asm., Complete	-	(1)
	50884A	Gearbox Asm., Complete	(1)	-

**CLARKETECHNOLOGY**  
**C2K-1600, C2K-1800, C2K-2000**

**Motor Assembly Drawing & Parts List 9/00**

**Note:** If your machine has motor #50858A or #50858B refer to this drawing for service part replacements.

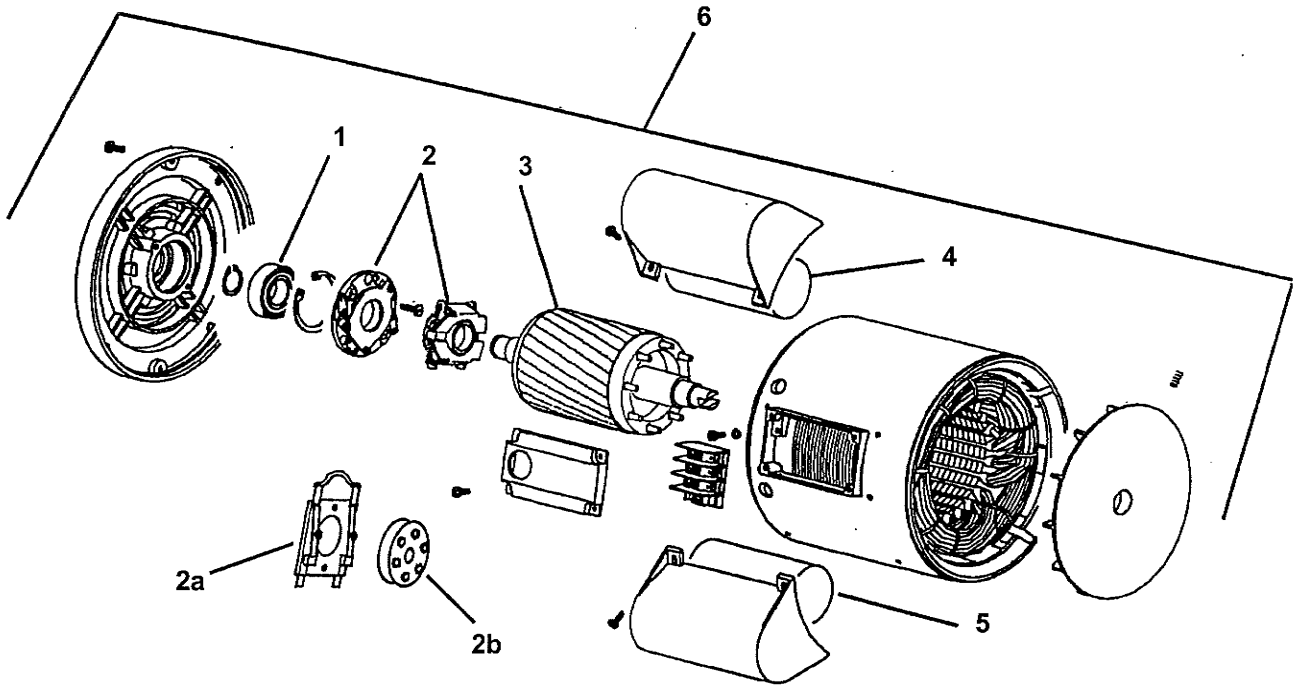

Ref.	50858A Part #'s	50858B Part #'s	Description	Qty
1	50861A	50861A	Ball Bearing	1
2	50860A		Centrifugal Switch	1
2(a)		51072A	Stationary Switch	1
2(b)		51070A	Centrifugal Mechanism	1
3	50859A	51073A	Rotor	1
4	50862A	50862A	Capacitor, Start	1
5	50863A	50863A	Capacitor, Run	1
6	50858A	50858B	Motor, Complete	(1)

**120V Motor  
 Connection Diagram**

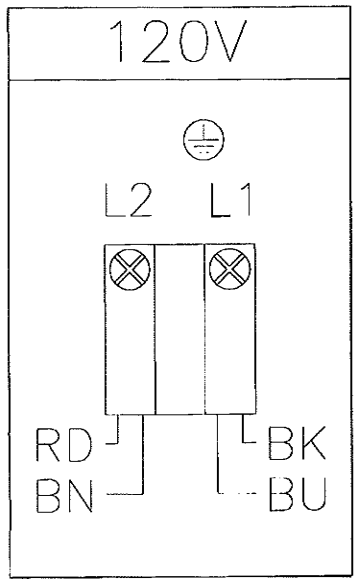

**CLARKETECHNOLOGY**  
**C2K-1600, C2K-1800, C2K-2000**  
**Gearbox Assembly Drawing & Parts List 2/01**

**NOTE:** If your machine has gearbox #50851A, refer to this drawing for service part replacement.

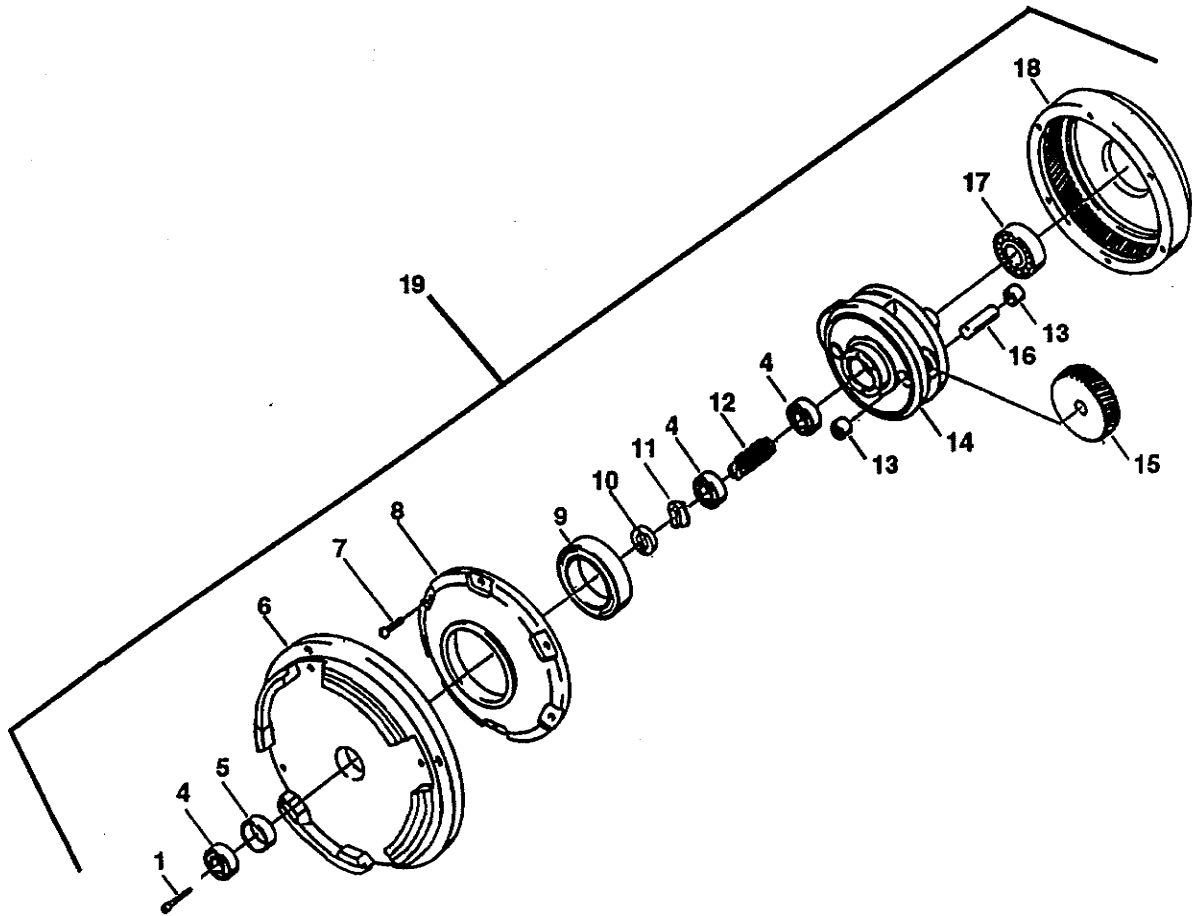

Note: ◆ indicates a change has been made since last publication of this manual

Ref	Part No.	Description	Qty.
1	80141A◆	Screw, Socket Hd. Cap	6
4	902606	Bearing, Ball	3
5	58520A	Spacer, Sleeve	1
6	50852A	Endshield	1
7	962794	Screw #10-24 x 1"	6
8	54858A	Cover, Housing	1
9	902736	Bearing	1
10	58314A	Retainer	1
11	442473	Coupling	1
12	58313A	Gear, Pinion	1
13	902737	Bearing, Needle	6
14	N/A	Cage	1
15	54408A	Gear, Idler	3
16	58312A	Shaft	3
17	902573	Bearing, Ball	1
18	54856A	Housing, Drive	1
19	50851A	Gearbox Asm., Complete	(1)

**CLARKETECHNOLOGY**  
**C2K-1600DS and C2K-2000DS**  
**120V Motor Assembly Drawing & Parts List 2/01**

**NOTE: If your machine has motor/gearbox #44651A, refer to this drawing for service part replacement.**

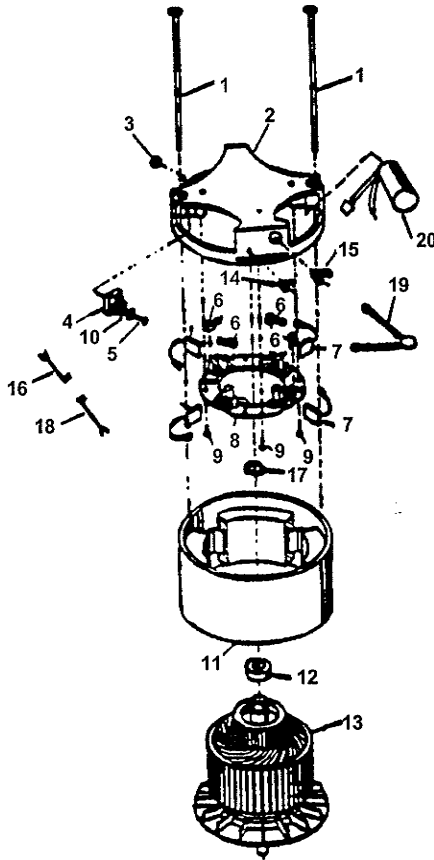

Note: ◆ indicates a change has been made since last publication of this manual

Ref	Part No.	Description	Qty.
1	50717A	Thru-Bolt	2
2	N/A	Commutator Bracket	1
3	56282A	Hex Nut	1
4	912287	Rectifier	1
5	962399	Screw	1
6	448396	Spring (Included with #8)	(4)
7	51405A	Brush Asm., (Included w/#8)	(4)
8	40410A◆	Brush Board Asm. (incl #'s 6,7,16, 18,19)	1
9	962310	Screw	4
10	980608	#8 Flat Washer	1
11	58057A	Stator Frame	1
12	902550	Bearing-Upper (Included w/#13)	(1)
13	40322A	Armature Asm. (Includes #12)	1
14	N/A	Strain Relief	1
15	N/A	Bushing	1
16	55648A	Red Lead (Included with #8)	1
17	980076	Wave Washer	1
18	55647A	Yellow Lead (Included with #8)	1
19	59606A	Varistor (Included w/#8)	(1)
20	46735A	Speed Control	1

**CLARKETECHNOLOGY**  
**C2K-1600DS and C2K-2000DS**  
**Gearbox Assembly Drawing & Parts List 2/01**

**NOTE: If your machine has gearbox #63602A, refer to this drawing for service part replacement.**

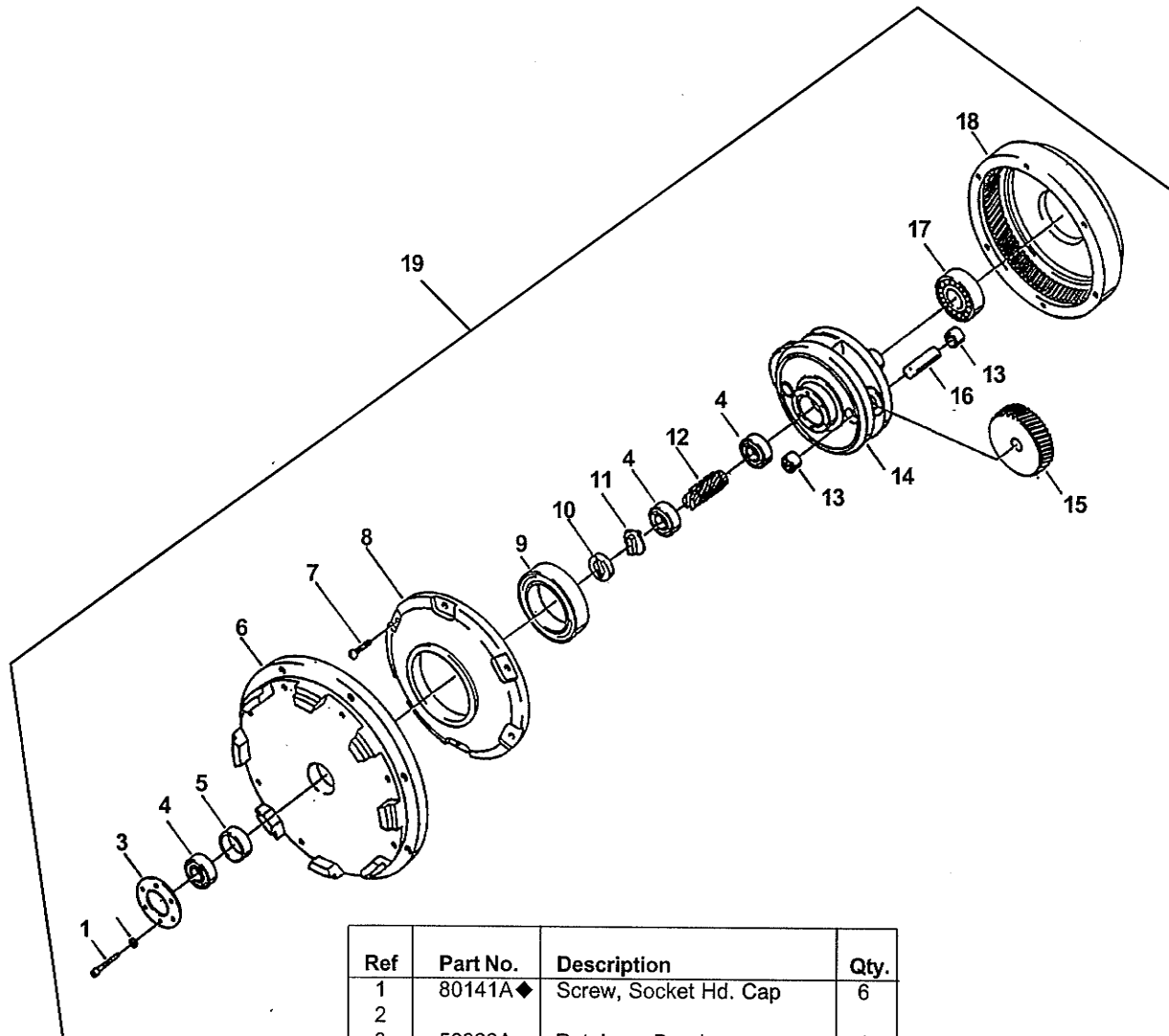

Note: ◆ indicates a change has taken place since last publication of this manual

Ref	Part No.	Description	Qty.
1	80141A◆	Screw, Socket Hd. Cap	6
2			
3	56922A	Retainer, Bearing	1
4	902606	Bearing, Ball	3
5	58520A	Spacer, Sleeve	1
6	53539A	Endshield	1
7	962794	Screw 10-24" x 1"	6
8	54858A	Cover, Housing	1
9	902736	Bearing	1
10	58314A	Retainer	1
11	442473	Coupling	1
12	58313A	Gear, Pinion	1
13	902737	Bearing, Needle	6
14	N/A	Cage	1
15	54408A	Gear, Idler	3
16	58312A	Shaft	3
17	902573	Bearing, Ball	1
18	54856A	Housing, Drive	1
19	63602A	Gearbox Asm., Complete	(1)

**CLARKETECHNOLOGY**  
**C2K-16, C2K-18, C2K-160, C2K-180, C2K-200,**  
**C2K-1600, C2K-1800, C2K-2000, C2K-160HS, C2K-180HS, C2K-200HS**  
**Wiring Diagram 120V-60Hz 9/99**

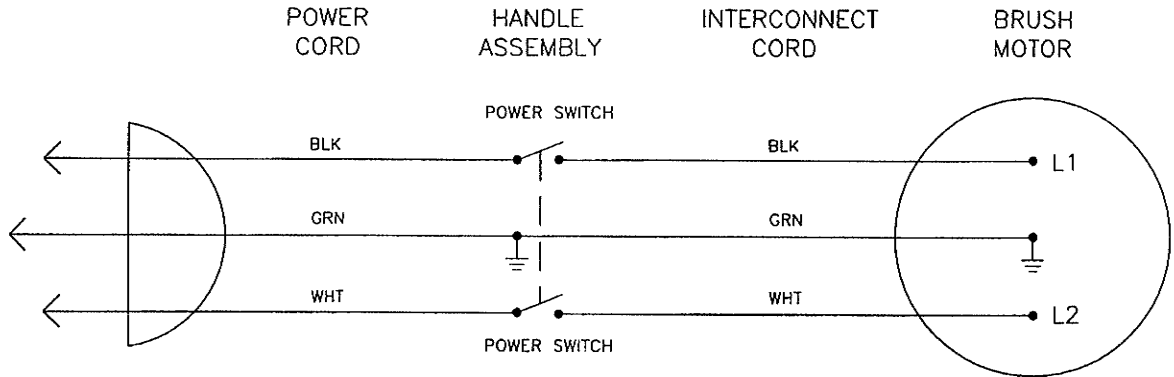

**CLARKETECHNOLOGY**  
**C2K-1600DS and C2K-2000DS**  
**Wiring Diagram 120V 9/99**

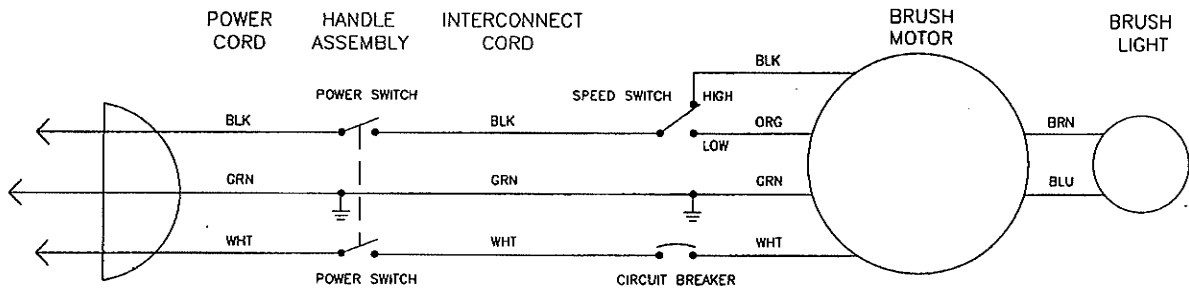

**⚠ WARNING: All electrical repairs must be performed by qualified personnel only.**



# ALTO® PRODUCT SUPPORT BRANCHES

## U. S. A. Locations

### HEAD OFFICE

ALTO U.S. Inc., St. Louis, Missouri  
16253 Swingley Ridge Road, Suite 200  
Chesterfield, Missouri 63017-1725

### PRODUCTION FACILITIES

ALTO U.S. Inc., Springdale, Arkansas  
2100 Highway 265  
Springdale, Arkansas 72764  
(501) 750-1000  
**Customer Service - 1-800-253-0367**  
**Technical Service - 1-800-356-7274**

ALTO U.S. Inc., Bowling Green, Ohio 43402  
1100 Haskins

ALTO U.S. Inc., Clearwater, Florida 33765  
1500 N. Belcher Road

### SERVICE FACILITIES

ALTO U.S. Inc., Carlstadt, New Jersey 07072  
150 Commerce Road  
(201) 460-4774

ALTO U.S. Inc., Elk Grove, Illinois 60007  
2280 Elmhurst Road  
(847) 956-7900

ALTO U.S. Inc., Denver, Colorado 80204  
1955 West 13th Ave.  
(303) 623-4367

ALTO U.S. Inc., Houston, Texas 77040  
7215 North Gessner Road

### SALES AND SERVICE FACILITIES

ALTO U.S. Inc., Madison Heights, Michigan 48071-0158  
29815 John R.  
(810) 544-6300

ALTO U.S. Inc., Marietta, Georgia 30062  
1355 West Oak Common Lane  
(770) 973-5225

---

**CLARKE TECHNOLOGY**  
**AMERICAN SANDERS TECHNOLOGY**  
**A.L. COOK TECHNOLOGY**

**Customer Service Headquarters and  
Factory**

2100 Highway 265  
Springdale, Arkansas 72764  
(501) 750-1000

**Technical Service**  
1-800-356-7274

## European Locations

### PRODUCTION FACILITIES

ALTO Danmark A/S, Aalborg  
Blytaekkervej 2  
DK-9000 Aalborg  
+45 72 18 21 00

ALTO Danmark A/S, Hadsund  
Industrikvarteret  
DK-9560 Hadsund  
+45 72 18 21 00

### SALES SUBSIDIARIES

ALTO Canada Ltd., Rexdale Ontario  
24 Constellation Ct.  
(416) 675-5830

ALTO Overseas Inc., Sydney (Australia)  
1B/8 Resolution Drive  
Caringbah NSW 2229  
+61 2 9524 6122

ALTO Cleaning Systems Asia Pte Ltd., Singapore  
No. 17 Link Road  
Singapore 619034  
+65 268 1006

ALTO Deutschland GmbH, Fronenberg (Germany)  
Ardeyer Str. 15  
D-58730 Fronenberg  
+49 2373 754 200

ALTO Cleaning Systems (UK) Ltd., Penrith  
Gilwilly Industrial Estate  
Penrith  
Cumbria CA11 9BN  
+44 1768 868 995

ALTO France S.A. Strasbourg  
B.P. 44, 4 Place d'Ostwald  
F-67036 Strasbourg  
Cedex 2  
+33 3 8828 8400

ALTO Nederland B.V. Vianen  
Stuartweg 4C  
NL-4131 NJ Vianen  
+31 347 324000

ALTO Sverige AB, Molndal (Sweden)  
Aminogatan 18  
Box 4029  
S-431 04 Molndal  
+46 31 706 73 00

ALTO Norge A/S, Oslo (Norway)  
Bjornerudveien 24  
N-1266  
+47 2275 1770

## **CLARKE TECHNOLOGY LIMITED U.S. WARRANTY**

This ALTO Industrial/Commercial Product is warranted to be free from defects in materials and workmanship under normal use and service for a period of five years from the date of purchase, when operated and maintained in accordance with Clarke Technology's Maintenance and Operations Instructions.

This warranty is extended only to the original purchaser for use of the product. It does not cover normal wear parts such as electrical cable, rubber parts and motor brushes.

Clarke Technology's liability under this warranty is limited to repair of the product and/or replacement of parts and is given to purchaser in lieu of all other remedies, including INCIDENTAL AND CONSEQUENTIAL DAMAGES.

THERE ARE NO EXPRESS WARRANTIES OTHER THAN THOSE SPECIFIED HEREIN. THERE ARE NO WARRANTIES WHICH EXTEND BEYOND THE DESCRIPTION OF THE FACE HEREOF. NO WARRANTIES, INCLUDING BUT NOT LIMITED TO WARRANTY OF MERCHANTABILITY, SHALL BE IMPLIED. A warranty registration card is provided with your Clarke Technology floor machine. Return the card to assist Clarke Technology in providing the performance you expect from your new floor machine.

If a difficulty develops with the product, you should: (a) Contact the nearest authorized Clarke Technology repair location or contact the Clarke Technology Service Operations Department, 2100 Highway 265, Springdale, AR 72764, for the nearest authorized Clarke Technology repair location. Only these locations are authorized to make repairs to the product under this warranty. (b) Return the product to the nearest Clarke Technology repair location. Transportation charges to and from the repair location must be prepaid by the purchaser. Clarke Technology will repair the product and/or replace any defective parts without charge within a reasonable time after receipt of the product.

ALTO U.S. Inc., 2100 Highway 265, Springdale, Arkansas 72764.

**ALTO reserves the right to make changes or improvements  
to its machine without notice.**

**Always use genuine Clarke Technology Parts for repair.**



**CLARKETECHNOLOGY  
2100 Highway 265  
Springdale, Arkansas, 72764**