



Electronic Service Manuals

This electronic document is provided as a service to our customers. We do not create the contents of the information contained in this document. Should you have detailed questions pertaining to the information contained in this document, you may contact Michco, or the manufacturer which provided the original information in this electronic deliverable. Michco's only part in this electronic deliverable was the electronic assembly process. By providing this manual on line we are not guaranteeing parts availability.

You may contact Michco through the following methods:

Phone (517) 484-9312 or (800) 331-3339

2011 N. High St. -- Lansing, Michigan -- 48906

Fax: (517) 484-9836

Email: CustServe@Michco.com

Web site: www.Michco.Com

Parts Web site: www.FloorMachineParts.Com

Order Parts on Line at:

www.FloorMachineParts.Com

Directly to Parts & Service:

By Email: **Shop@Michco.com**

By Fax: (517) 702-2041

By Voice: Use numbers above.

Serving the Cleaning Industry Since 1922

Notice: All copyrighted material remains property of original owners, all trademarks are property of respective owners. Manuals are subject to Manufacturer's reproduction limitations. Originals or reproductions were provided by manufacturers through a request. We make no warranty as to the correctness of information provided in this document and you assume all risk. By placing these manuals on line we are not declaring our corporation to be an manufacturer authorized dealer or provider, please check our web site for authorized manufacturers we represent.

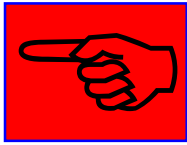

**Operator's
Manual**

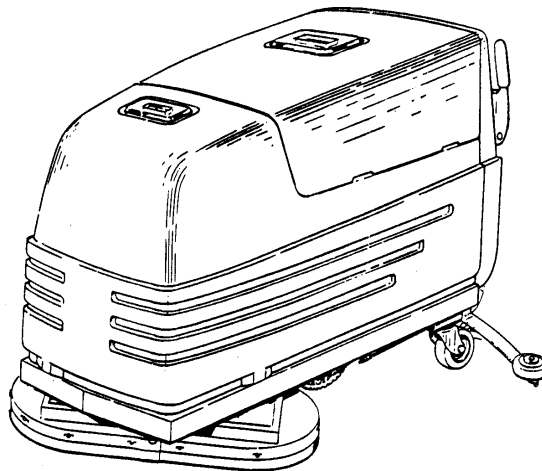

**Vision 21i
VisionV**

READ THIS BOOK

This book has important information for the use and safe operation of this machine. Failure to read this book prior to operating or attempting any service or maintenance procedure to your ALTO machine could result in injury to you or to other personnel; damage to the machine or other property could occur as well. You must have training in the operation of this machine before using it. If you or your operator(s) cannot read English, have this manual explained fully before attempting to operate this machine.

Si Ud. o sus operadores no pueden leer el Inglés, se hagan explicar este manual completamente antes de tratar el manejo o servicio de esta máquina.

All directions given in this book are as seen from the operator's position at the rear of the machine.

For new books write to: ALTO U.S. INC., 2100 Highway 265, Springdale, Arkansas 72764.

Table of Contents

Operator Safety Instructions	3
Introduction & Machine Specifications	5
Procedures For Transporting	6
Symbols Used On Vision 21i & Vision V	7
Machine Control Panel 21i & Vision V	8
Machine Control Panel 21i & Vision V	9
Machine Controls and Features	10
How To Prepare The Machine For Operation	11
How To Install The Batteries	11
Battery Maintenance	12
How To Charge The Batteries	13
How To Install The Brushes Or Pad Drivers	14
How To Remove The Brushes Or Pad Drivers	14
How To Operate The Machine	15
How To Operate The Squeegee	15
How To Fill The Solution Tank	15
How To Clean A Floor	17
How To Correct Problems In The Machine	18
Maintenance	20
Accessories	25

Drawings and Part Lists



Vision 21i - Vision V Rear Cover Assembly Drawing	26
Parts List	27
Vision 21i - Vision V Traverse System Assembly Drawing	28
Parts List	29
Vision 21i - Vision V Squeegee & Squeegee Arm Assembly Drawing	30
Parts List	31
Vision 21i - Vision V Brush Head Assembly Drawing	32
Parts List	33
Vision 21i - Vision V Solution/Vacuum System Drawing	34
Parts List	35
Vision 21i - Vision V Brush Housing Assembly	36
Parts List	37
Vision 21i - Vision V Alternate Brush Motor (44809A) Assembly Drawing and Parts List	38
Vision 21i - Vision V Alternate Brush Motor (44809A) Drawing and Parts List	39
Vision 21i - Vision V Brush Motor (45037A) Drawing & Parts List	40
Vision 21i - Vision V Traverse Motor (45038A) Drawing & Parts List	41
Battery Charger Drawing & Parts List	42
Vision 21i - Vision V Vac Motor (44917A)	43
Vision 21i - Vision V Electrical Schematic	44
Vision 21i - Vision V Connection Diagram, Front of Machine	45
Vision 21i - Vision V Connection Diagram, Rear of Machine	46
Vision 21i - Vision V Connection Diagram, Inside Rear Cover	









OPERATOR SAFETY INSTRUCTIONS

 **WARNING**

 **AVERTISSEMENT**

 **ADVERTENCIA**

-  **DANGER:** Failure to read and observe all **DANGER** statements could result in severe bodily injury or death. Read and observe all **DANGER** statements found in your Owner's Manual and on your machine.
-  **WARNING:** Failure to read and observe all **WARNING** statements could result in injury to you or to other personnel; property damage could occur as well. Read and observe all **WARNING** statements found in your Owner's Manual and on your machine.
-  **CAUTION:** Failure to read and observe all **CAUTION** statements could result in damage to the machine or to other property. Read and observe all **CAUTION** statements found in our Owner's Manual and on your machine.

-  **DANGER:** Failure to read the Owner's Manual prior to operating or attempting any service or maintenance procedure to your Clarke Technology machine could result in injury to you or to other personnel; damage to the machine or to other property could occur as well. You must have training in the operation of this machine before using it. If you or your operator(s) cannot read English, have this manual explained fully before attempting to operate this machine.
-  **DANGER:** Operating a machine that is not completely or fully assembled could result in injury or property damage. Do not operate this machine until it is completely assembled. Inspect the machine carefully before operation.
-  **DANGER:** Machines can cause an explosion when operated near flammable materials and vapors. Do not use this machine with or near fuels, grain dust, solvents, thinners, or other flammable materials.
-  **DANGER:** Lead acid batteries generate gases which can cause an explosion. Keep sparks and flames away from batteries. Do not smoke around the machine. Charge the batteries only in an area with good ventilation. Make sure that you unplug the AC charger from the wall outlet before disconnecting from the machine.
-  **DANGER:** Working with batteries can be dangerous! Always wear eye protection and protective clothing when working near batteries. Remove all jewelry. Do not put tools or other metal objects across the battery terminals, or the tops of the batteries.
-  **DANGER:** Using a charger with a damaged power cord could result in an electrocution. Do not use the charger if the power cord is damaged.
-  **WARNING:** Operating this machine from anywhere other than the back of the machine could result in injury or damage. Operate this machine only from the rear.
-  **WARNING:** This machine is heavy. Get assistance before attempting to transport or move it. Use two able persons to move the machine on a ramp or incline. Always move slowly. Do not turn the machine on a ramp. Do not stop and leave the machine on a ramp or incline. Read the "Procedures For Transporting" in this manual before transporting.
-  **WARNING:** Machines can topple over if guided over the edges of stairs or loading docks and cause injury or damage. Stop and leave this machine only on a level surface. When you stop the machine, turn the key "OFF".



WARNING: Maintenance and repairs performed by unauthorized personnel could result in damage or injury. Maintenance and repairs must be performed by authorized Clarke Technology personnel only



WARNING: Any alterations or modifications of this machine could result in damage to the machine or injury to the operator or other bystanders. Alterations or modifications not authorized by the manufacturer voids any and all warranties and liabilities.



WARNING: Electrical components of this machine can "short-out" if exposed to water or moisture. Keep the electrical components of the machine dry. Wipe the machine down after each use. For storage, keep the machine in a dry building.



WARNING: Operating a machine without observing all labels and instructional information could result in injury or damage. Read all machine labels before attempting to operate. Make sure all of the labels and instructional information are attached or fastened to the machine. Get replacement labels and plates from your Clarke Technology distributor.



WARNING: Wet floor surfaces can be slippery. Water solutions or cleaning materials used with this type of machine can leave wet areas on the floor surface. These areas can cause a dangerous condition for the operator or other persons. Always put "Caution" signs around/near the area you are cleaning.



CAUTION: Use of this machine to move other objects or to climb on could result in injury or damage. Do not use this machine as a step or furniture. Do not ride on this machine.



CAUTION: Your machine warranty will be voided if anything other than genuine Clarke Technology parts are used on your machine. Always use Clarke Technology parts for replacement.

Introduction & Machine Specifications

Introduction & Machine Specifications

Clarke Technology's newly designed Vision 21i & Vision V automatic scrubbers are efficient and superior floor cleaning machines. The Vision 21i uses two brushes or pads to scrub a path 21 inches wide. The Vision V uses two brushes or pads to scrub a path 26 inches wide. A squeegee wipes the floor while the vacuum motor removes the dirty solution from the floor - all in one pass.

The Vision 21i or Vision V automatic scrubbers come complete with four - 6 volt batteries or two - 12 volt batteries, one battery charger, either two brushes or two pad drivers, and one operator's manual.

SPECIFICATIONS:

Model	Vision V- 00590A	Vision 21i-00610A
Motor, Vac	¾ HP three stage tangential discharge - 21 Amp	¾HP three stage tagential discharge - 21 Amp
Power Supply	24 volt* 195AH, 250AH	24 volt * 195AH, 250AH
Solution Tank	20 gallon (76 liter)	20 gallon (76 liter)
Recovery Tank	20 gallon (76 liter)	20 gallon (76 liter)
Parabolic Squeegee	37 inches (94 cm)	27 inches (69 cm)
Motors, Brush (2)	.5 hp PM (.37 kw) 23 amp	.5 hpPM (.37 kw) 23 amp
Motor Traction	.5 hp PM (.37kw) 23 amp	.5 hp PM (.37kw) 23 amp
Drive Train	Direct Drive, Roller Chain	Direct Drive, RollerChain
Brushes (2)	13 inch (33cm)	11 inch (28cm)
Brush Speed	320 rpm	320 rpm
Brush Pressure	100 lbs.	100 lbs
Speed, Forward	3 speeds to 220ft/min.	3 speeds to 220ft/min.
Speed, Reverse	2 speeds to 170ft/min.	2 speeds to 170ft/min.
Drive Wheel	12"x6" (30x15cm)	12"x6" (30x15cm)
Charger	24V, 25A, 115V/60hz	24V, 25A, 115V/60hz
Length	58 inches (147cm)	57 inches (145cm)
Width	27 inches (70cm)	23 inches (58cm)
Height	42 inches (106cm)	42 inches (106cm)
Cleaning Rate	29,000 sq ft/hr (2,694 sq. m/hr)	23,000 sq ft/hr (2,136 sq. m/hr)
Cleaning Swath	26 inch (66cm)	21 inch (53cm)
Grade Cleaning	5° Incline	5° Incline
Weight	492 lbs.	462 lbs.
Shipping Weight	602 lbs.	572 lbs.
Battery Weight(4-250 AH)	264 lbs.	264 lbs.
(2-195 AH)	224 lbs.	224 lbs.

NOTE: * 24V (4-6v batteries or 2-12v batteries)

PROCEDURES FOR TRANSPORTING

How To Put The Machine In A Van Or Truck

 **WARNING:** The machine is heavy. Make sure you use two able persons to assist the machine in climbing the ramp.

1. Make sure the loading ramp is at least eight (8) feet long, and strong enough to support the machine.
2. Make sure the ramp is clean and dry.
3. Put the ramp in position.
4. Remove squeegee assembly, brush housings, & brushes or pad drivers before loading.
5. Turn key switch "ON".
6. Align the machine on a level surface ten (10) feet in front of the ramp.
7. Put the traverse speed switch in the "HI" position.
8. Push the control handles toward the machine all the way.
9. Push the machine to the top of the ramp.
10. Engage the parking brake.
11. Turn the key switch "OFF".
12. Fasten the machine to the vehicle.

How To Remove The Machine From A Van Or Truck

1. Make sure there are no obstructions in the area.
2. Make sure the unloading ramp is at least eight (8) feet long and strong enough to support the machine.
3. Make sure the ramp is clean and dry.
4. Put the ramp in position.
5. Unfasten the machine.

 **WARNING:** The machine is heavy. Make sure you use two able persons to assist in moving the machine down the ramp.

6. Turn the key switch "ON".
7. Release the parking brake.
8. Put the traverse speed switch in the "HI" position.
9. Carefully and slowly, pull the machine to the top of the ramp.
10. As the machine begins to travel down the ramp, push the control handles toward the machine to maintain a slow downward speed.
11. Replace squeegee assembly, brush housings, & brushes or pad drivers after the machine is unloaded and ready to use.

SYMBOLS USED ON VISION 21i & Vision V



Warning



Power

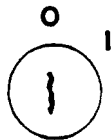

On/Off Key Switch

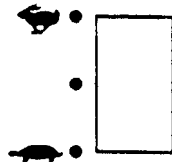

Traverse Speed



Solution Control

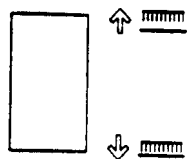

Brush Up/Down

MACHINE CONTROL PANEL (Vision 21i & Vision V)

Key Switch (See Figure #1, Item "A")

The key switch turns "ON" the power to the control panel. "0" is "OFF" and "1" is "on".

Traverse Speed Switch (See Figure #1, Item "B")

The speed switch has three positions: High, Medium, and Low speeds.

Brush Position Switch (See Figure #1, Item "C")

The brush switch has two positions: "Up" positions the brushes up; "Down" positions the brushes on the floor. The brush motors start when the brushes are down.

Solution Control Knob (See Figure #1, Item "D")

The solution control knob regulates the flow of cleaning solution to the floor. To increase the flow turn the knob clockwise. To decrease the flow, turn the knob counter-clockwise.

Control Handles (See Figure #1, Item "E")

The control handles are located at the rear of the machine. They control the direction of the machine. Push forward to go forward. (See Figure #2, page 7). Pull back to move in reverse. (See Figure #3, page 7).

Circuit Breakers (See Figure #1, Item "F"-"J")

The circuit breaker reset buttons are located on the rear cover, below the control handle. The breakers are located as follows:

- Item F & G - Brush Motors (35A)
- Item H - Traverse Motor (30A)
- Item I - Vac Motor (30A)
- Item J - Actuator Motor, Brush Head (5A)

If a circuit breaker trips, determine which motor is not operating and turn the key switch "OFF". Wait five minutes and push the reset button back in. Turn the key switch "ON", and try again. An authorized service person should be contacted if the breaker trips again.

MACHINE CONTROL PANEL (Vision 21i & Vision V)

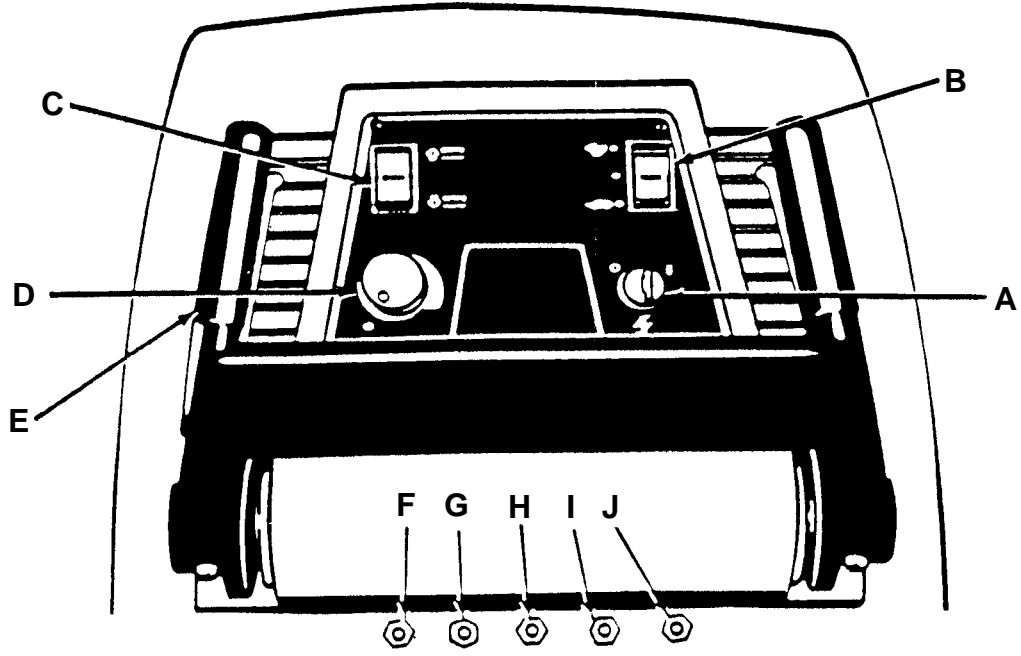
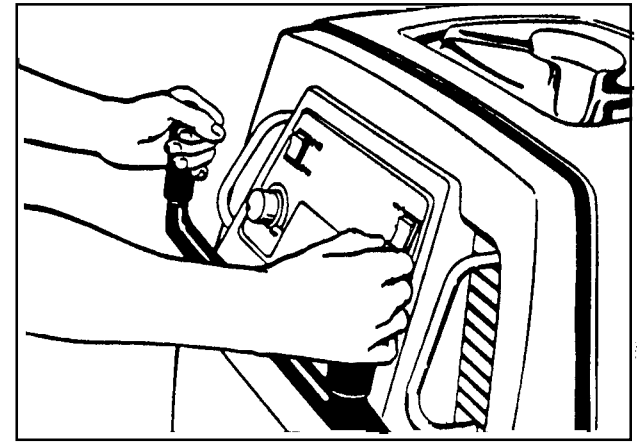
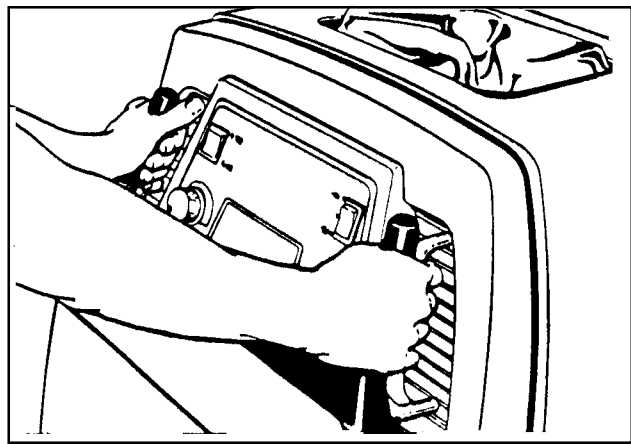

Figure #1

Figure #2

Figure #3



MACHINE CONTROLS & FEATURES

Squeegee Lift Handle. See Figure #4a & #4b.

The squeegee lift handle is located below the control handles on the right side. It is used to raise or lower the squeegee. The vac motor is turned on when the handle is lowered.

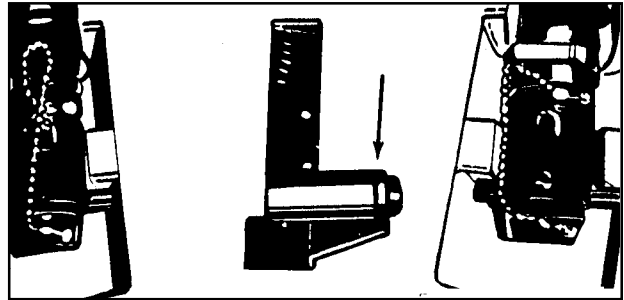

Figure #4a

Float Shut Off. See Figure #5.

The shut-off switch for the vac motor is located in the recovery tank. It automatically turns off the vac motor when the recovery tank is full.

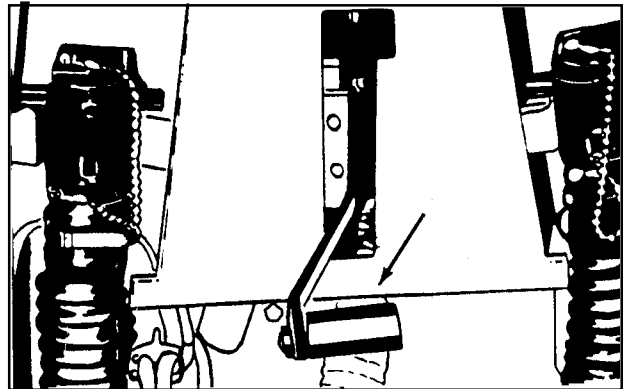

Figure #4b.

Parking Brake. See Figure #6a & #6b.

The parking brake prevents movement of the machine. It is located at the rear lower left side of the machine. To engage the brake, push the pedal down (Figure #6a). To release the brake, lift pedal up (Figure #6b).

CAUTION: Do not activate the brake while the machine is moving.

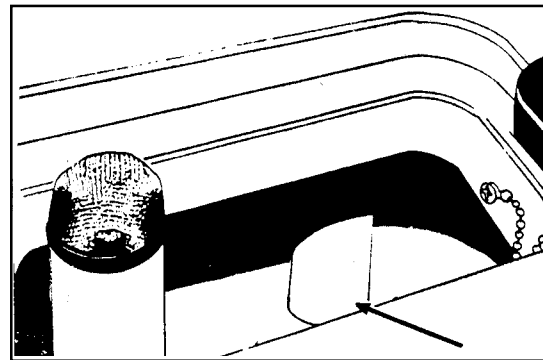

Figure #5.

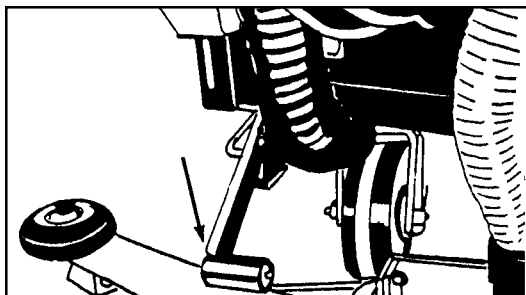

Figure #6a.

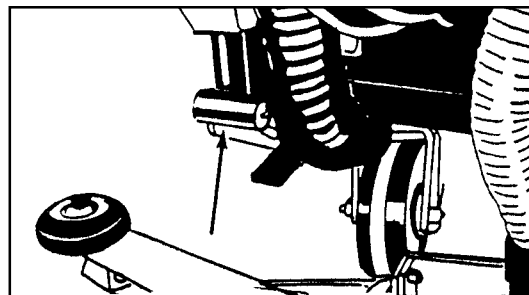

Figure #6b.

HOW TO PREPARE THE MACHINE FOR OPERATION

How To Install The Batteries

The Vision 21i and Vision V machines use four 6-volt or two 12-volt batteries. The batteries are located in the battery compartment under the recovery tank.

To Install the batteries, follow this procedure:

1. Set the parking brake.
2. Make sure both tanks are empty.
3. Disconnect the hoses from the recovery tank (upper tank) & unplug the vac motor. Remove the recovery tank.
4. Remove the two screws that attach the solution tank (lower tank) to the back of the frame, leaving the two angle brackets attached to the tank.
5. Disconnect the two hoses under the right side and remove the solution tank.
6. Place the batteries in the tray as shown in figure #7a, #7b, or #7c.

⚠ WARNING: Lifting batteries without help could result in an injury. Get help to lift the batteries. The batteries are heavy.

⚠ WARNING: Working with batteries can be dangerous. Always wear eye protection and protective clothing when working near batteries. **NO SMOKING!**

7. Connect the battery cables between batteries and install long battery cable assembly as indicated. See figure #7.
8. Join the connector from the battery pack to the connector on the control panel. See figure #8.
9. Install the tank, reconnecting hoses and replace the two screws attaching the solution tank to the rear of the frame.

NOTE: Charge the batteries before using the machine.

Figure #7a

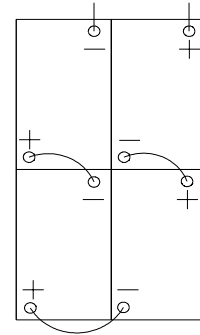

All 6 Volt
Poly Case Batteries

Figure #7b

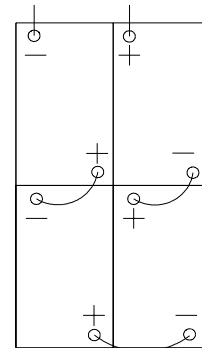

330 AH, 6 Volt
Black Rubber Case Battery

Figure #7c

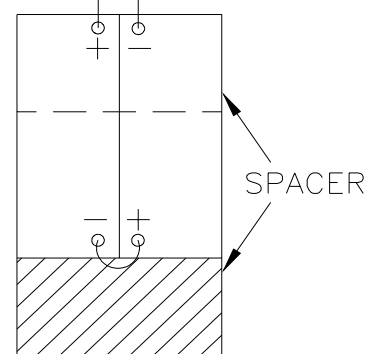

12 Volt 195 AH

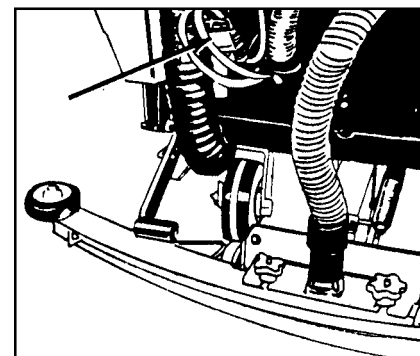

Figure #8

HOW TO PREPARE THE MACHINE FOR OPERATION

Battery Maintenance

The electrical power to operate the machine comes from the storage batteries. Storage batteries need preventive maintenance.

⚠ WARNING: Working with batteries can be dangerous. Always wear eye protection and protective clothing when working near batteries. NO SMOKING!

To maintain the batteries in good condition, follow these instructions:

1. Keep the electrolyte at the correct level. The correct level is between 1/4" below the bottom of the tube in each cell and above the tops of the plates. Check the level of the electrolyte each time you charge the batteries. See figure #9.

NOTE: Check the level of electrolyte prior to charging the batteries. Be sure the plates in each cell are covered with electrolyte. Do not top off the cells prior to charging the battery. Electrolyte expands during charging. As a result, the electrolyte could overflow from the cells. Always top off the cells with distilled water after charging.

⚠ CAUTION: Irreversible damage will occur to the batteries if the electrolyte level does not cover the plates. Keep the electrolyte at the correct level.

⚠ CAUTION: Machine damage and discharge across the tops of the batteries can occur if the batteries are filled above the bottom of the tube in each cell. Do not fill the batteries up to the bottom of the tube in each cell. Wipe any acid from the machine or the tops of the batteries. Never add acid to a battery after installation.

⚠ CAUTION: Tap water may contain contaminants that will damage batteries. Batteries must be re-filled with distilled water only.

2. Keep the tops of the batteries clean and dry. Keep the terminals and connectors clean. To clean the top of the batteries, use a damp cloth with a weak solution of ammonia or bicarbonate of soda solution. To clean the terminals and connectors, use a terminal and connector cleaning tool. Do not allow ammonia or bicarbonate of soda to get into batteries.
3. Keep the batteries charged.

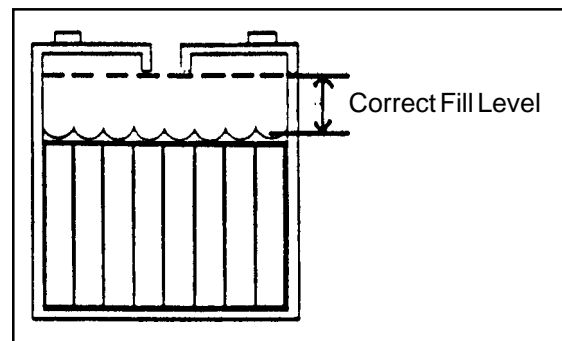

Figure #9

HOW TO PREPARE THE MACHINE FOR OPERATION

How To Charge The Batteries

- ⚠ WARNING:** Charging the batteries in an area without adequate ventilation could result in an explosion. To prevent an explosion, charge the batteries only in an area with good ventilation.
- ⚠ WARNING:** Lead acid batteries generate gases which could explode. Keep sparks and flames away from batteries. **NO SMOKING!**
- ⚠ WARNING:** Failure to disconnect the AC plug from the wall receptacle before connecting or disconnecting the DC connector on the charger could result in an explosion. Always disconnect the AC plug from the wall receptacle before connecting or disconnecting the DC connector on the charger.

To charge the batteries, follow this procedure:

1. Put the charger on a flat surface. Make sure the vents on the sides are at least two inches away from walls and other objects. Make sure there are no objects near the vents on the bottom of the charger.
2. Set the parking brake by putting it into the down position. See figure #10. Make sure the key switch is "OFF" position.
3. Disconnect the battery pack connector from the control housing connector. See figure # 11.
4. Connect the DC connector on the charger to the battery pack connector. See figure #12.
5. Connect the charger to a properly grounded single phase (3-wire) wall receptacle having the voltage, frequency, and ampere capacity specified on the nameplate of the charger.

For more instruction on the use of the charger, read the instruction book supplied with the charger.

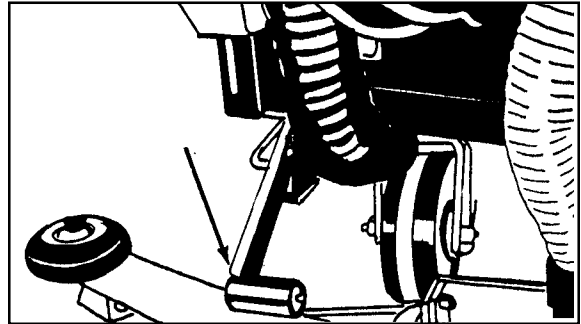

Figure # 10

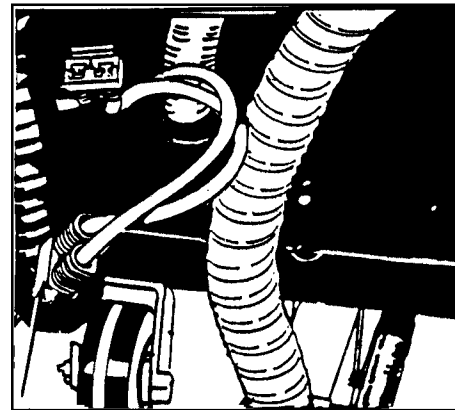

Figure #11

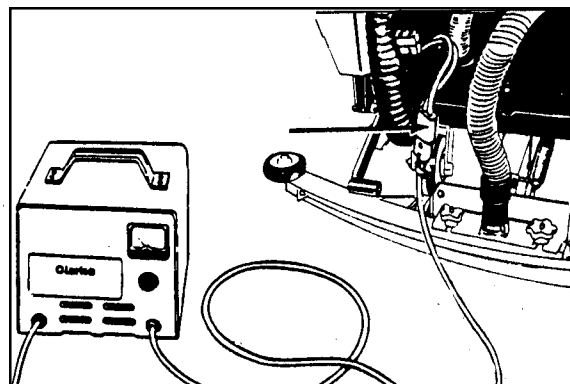

Figure #12

HOW TO PREPARE THE MACHINE FOR OPERATION

How To Install The Brushes Or Pad Drivers

To install the brushes or pad drivers on the machine, follow this procedure:

1. Engage the parking brake.
2. Turn the key switch "ON".
3. Put the brush switch in the "UP" position.
4. Turn the key switch "OFF".
5. Go to the front of the machine.
6. Pull out the brush housing pin and remove the right and left brush housings.
7. Put a brush or pad driver under the brush motor plate. See figure #13.
8. Align the lugs on the motor gimbal with the slots in the brush gimbal.
9. Pull the brush up until the gimbal locks.
10. Repeat steps 7, 8, and 9 to install the second brush or pad driver.

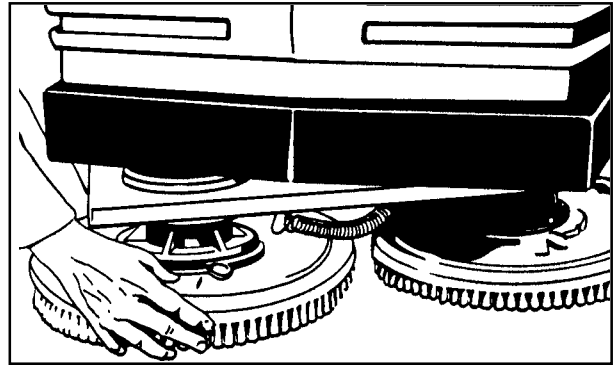

Figure # 13

How To Remove The Brushes Or Pad Drivers

To remove the brushes or pad drivers from the machine, follow this procedure:

1. Engage the parking brake.
2. Turn the key switch "ON".
3. Put the brush switch in the "UP" position.
4. Turn the key switch "OFF".
5. Go to the front of the machine.
6. Push down on two sides of the brush or pad driver until the gimbals release.

HOW TO OPERATE THE MACHINE

How To Operate the Squeegee

The squeegee wipes the floor while the vacuum motor removes the dirty solution from the floor. Use your right hand to lower or raise the squeegee handle. To operate the squeegee, follow this procedure:

1. To lower the squeegee and start the vac motor move the squeegee lever to the right and down. See figure #14a.
2. To raise the squeegee, lift the squeegee lever up. See figure #14b.

Note: The center position lets the vac motor continue to run with the squeegee off the floor to avoid drips.

How to Fill The Solution Tank

⚠ CAUTION: Make sure water or solution does not enter the opening for the vacuum motor. See figure #15.

The solution tank lid is at the front. To fill the solution tank follow this procedure:

1. Remove the solution tank lid.
2. Fill the solution tank with water.
3. Add a cleaning chemical to the water. for the correct amount, follow the directions shown on the container.
4. Replace the solution tank lid.

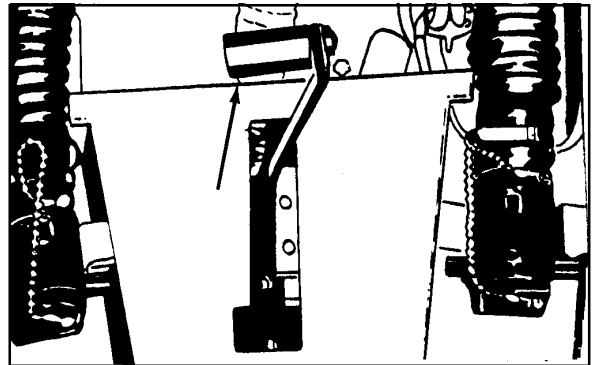

Figure #14a

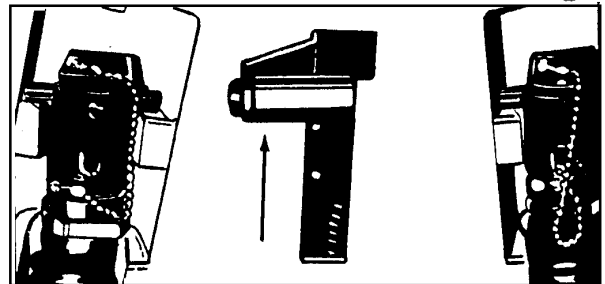

Figure #14b

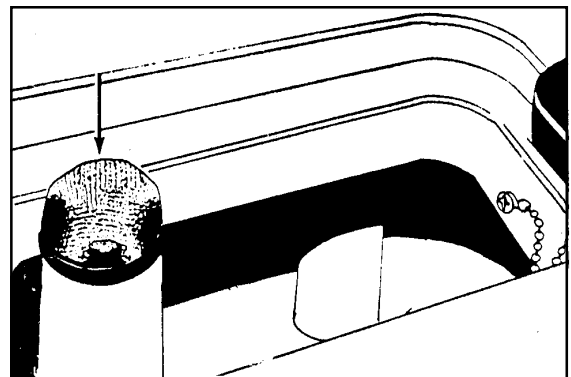

Figure #15

HOW TO OPERATE THE MACHINE (cont.)

⚠ WARNING: Water solutions or cleaning materials used with this type of machine can leave wet areas on the floor surface. These areas can cause a dangerous condition for the operator or other persons. Always put CAUTION signs near the area you are cleaning.

⚠ WARNING: Machines can ignite flammable materials and vapors. Do not use with or near flammables such as gasoline, grain dust, solvents and thinners. Only use a cleaning concentrate recommended by the chemical manufacturer.

NOTE: Put the machine in the "LO" traverse speed. Use the machine in an area that has no furniture and objects until you can do the following:

1. Move the machine in a straight direction, forward and backward.
2. Stop the machine safely.
3. Move the machine in a straight direction after you turn the machine.

To move the machine, follow this procedure:

1. Release the parking brake.
2. Turn the key switch "ON" position.
3. Put the brush switch in the "UP" position.
4. Raise the squeegee.
5. To go forward, push the control handles toward the machine. See figure #16.
6. To stop the machine, put the handles in the center position.
7. To go backward, pull the handles away from the machine. See figure #17.
8. To turn the machine, push the rear of the machine to the side.
9. When you stop the machine, turn the key switch "OFF".

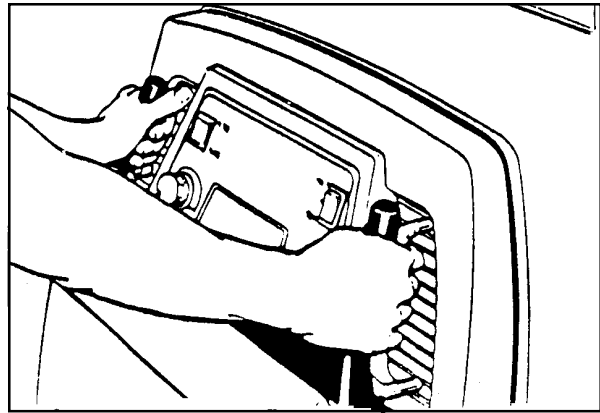

Figure # 16

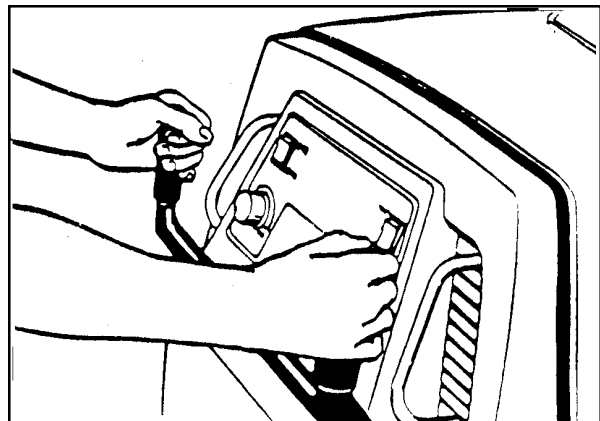

Figure #17

HOW TO OPERATE THE MACHINE (cont.)

HOW TO CLEAN A FLOOR

▲ WARNING: Water solutions or cleaning materials used with this type of machine can leave wet areas on the floor surfaces. These areas can cause a dangerous condition for the operator or other persons. Always put CAUTION signs near the area you are cleaning.

To clean a floor, follow this procedure:

1. Set the parking brake.
2. Put the water and a cleaning chemical in the clean solution tank.
3. Release the parking brake.
4. Turn the key switch "ON".
5. Lower the squeegee.
6. Put the brush switch in the "DOWN" position.

NOTE: Keep the machine moving when the brushes are rotating on the floor. (I models only)

7. Turn the solution knob to the right to activate the flow of solution. Adjust the flow of clean solution to the flow desired.
8. Move the machine across the floor in the forward direction. See figure #18 (1).
9. When the machine is one machine length from the end of the area to be cleaned (figure #18 (2)), rotate the solution knob to the left.
10. Make a 180° turn. See figure #18 (3).

NOTE: When you make more passes across the floor, let the brushes clean approximately 2 inches of the area already cleaned by the brushes. See figure #18 (4).

NOTE: During most cleaning procedures, apply and remove the solution in one operation.

HOW TO CLEAN A VERY DIRTY FLOOR

To clean a very dirty floor, follow this procedure:

1. Apply solution to the floor.
2. Do not lower the squeegee.
3. Do not activate the vacuum motor.
4. Lower the brushes and scrub the floor.
5. Leave the solution on the floor long enough for the solution to begin cleaning the floor.
6. Scrub the floor again with additional solution, picking up all the solution with the squeegee

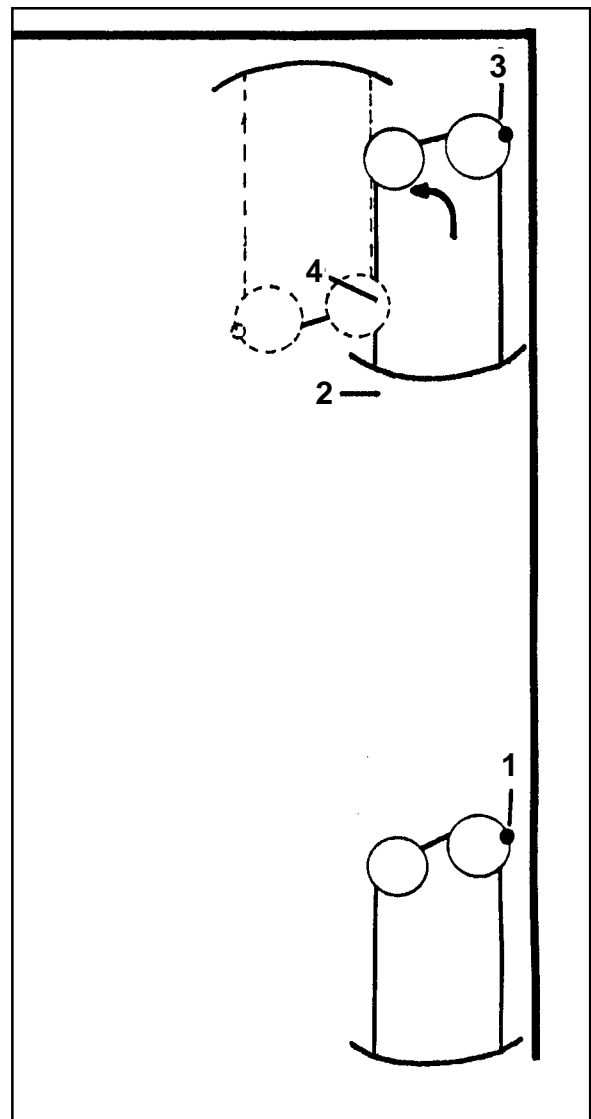

Figure #18

HOW TO CORRECT PROBLEMS IN THE MACHINE

PROBLEM	CAUSE	ACTION
There is no solution flow.	<p>The solution valve is closed.</p> <p>There is an obstruction in the solution hose or filter.</p> <p>The solution valve or linkage is damaged.</p> <p>The solution tank is empty.</p>	<p>Open the solution valve.</p> <p>Remove the obstruction from the hose and the filter.</p> <p>Repair or replace the valve and the linkage.</p> <p>Fill the solution tank.</p>
The solution flow does not stop.	<p>The solution valve is open.</p> <p>The solution valve or linkage is damaged.</p> <p>The solution valve is dirty</p> <p>There is a damaged seat and washer in the solution valve.</p> <p>The valve stem is dirty</p>	<p>Close the solution valve.</p> <p>Repair or replace the valve and the linkage.</p> <p>Clean the solution valve.</p> <p>Replace the seat and washer.</p> <p>Clean and lubricate valve stem.</p>
The machine does not remove all the water from the floor.	<p>The squeegee is up</p> <p>The squeegee tilt is not correct.</p> <p>The vacuum tank is full.</p> <p>The screen filter is dirty.</p> <p>There is an obstruction or damage in the squeegee, squeegee hose or standpipe.</p> <p>The vacuum motor is not running.</p> <p>The squeegee hose is disconnected.</p> <p>The squeegee blade is damaged, worn, or incorrectly installed.</p> <p>The squeegee pressure is not correctly adjusted.</p> <p>The gaskets on the cover of the recovery tank are damaged.</p>	<p>Lower the squeegee.</p> <p>(See Figure 27)</p> <p>Drain the tank.</p> <p>Clean the screen filter.</p> <p>Remove the obstruction or repair the damage.</p> <p>Check for tripped breaker. Have an authorized service person make repairs.</p> <p>Connect the hose.</p> <p>Turn or replace the squeegee blade. Correctly install the squeegee blade.</p> <p>Adjust the pressure of the squeegee.</p> <p>Replace the gaskets.</p>
The batteries do not give the normal running time.	<p>The battery terminals are dirty or damaged.</p> <p>The electrolyte level is too low.</p> <p>The batteries are not fully charged.</p> <p>The charger is damaged.</p> <p>The battery is defective.</p> <p>The batteries are disconnected.</p>	<p>Clean the terminals and connectors. Replace the damaged cables. Charge the batteries.</p> <p>Add distilled water to each cell and charge the batteries.</p> <p>Charge the batteries for a full 16 hour charge.</p> <p>Have an authorized service person repair the charger.</p> <p>Check voltage of each cell while discharging.</p> <p>Connect the batteries.</p>

MAINTENANCE

- ⚠ WARNING:** Maintenance and repairs must be done by authorized personnel only.
- ⚠ WARNING:** Always empty the solution tank and recovery tank before doing any maintenance.
- ⚠ WARNING:** Keep all fasteners tight.

These Maintenance Procedures Must Be Done Every Day

Keep the machine clean, it will need fewer repairs and have longer life.

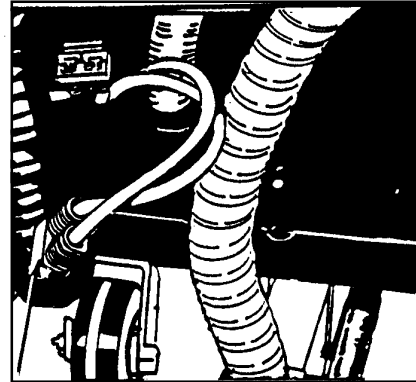

Figure #19

Do These Procedures When You Begin Your Work Period

NOTE: Always engage the parking brake before servicing the machine.

1. Disconnect the plug on the charger from the connector on the back of the machine. See figure #19
2. Join the connector from the batteries (1) to the control panel cable connection. See figure #19.
3. Make sure the recovery tank lid is on correctly. See figure #20, Item A.
4. Make sure the Screen filter over the vacuum motor is clean and in position. See figure #21, Item B.
5. Make sure the valves on the drain hoses are clean. Tightly close the valves.
6. Make sure brush housings and skirts are in position on the brush head.
7. Make sure the brushes are in position and installed correctly
8. Check the installation of the squeegee and squeegee hose.

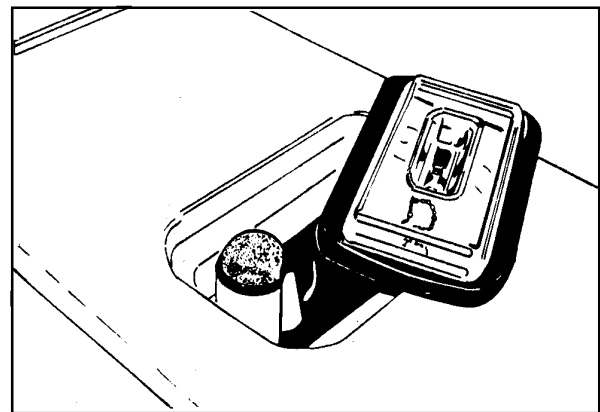

Figure #20

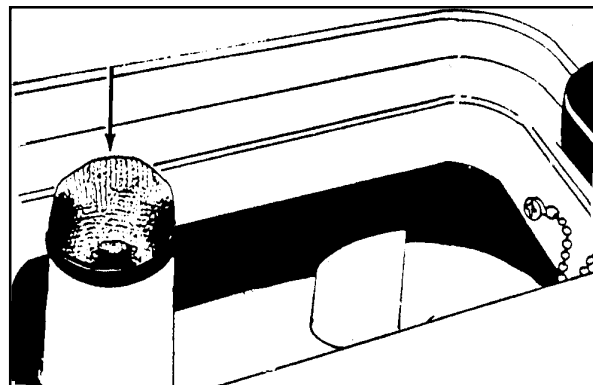

Figure #21

MAINTENANCE

Do These Procedures When You End Your Work

NOTE: Always engage the parking brake before servicing the machine.

1. Drain the solution tank (Figure #22a) and the recovery tank (Figure #22b). To drain the tanks, follow this procedure:
 - a. Turn the key switch "OFF".
 - b. Remove the drain hose from the back of the machine.
 - c. Put the end of the hose over a drain or bucket.
 - d. Turn the valve handle to the left. Pull the handle out to open the drain. (Figure #22c)

NOTE: Have the opening in the side of the valve away from you when you open the valve.

- e. To open the valve completely, turn the handle to the right. Pull the handle out of valve. (Figure #22d)
2. Flush the tanks. To flush the tanks, put clean water in the tank through the opening on top of the tank.
3. If a tank or drain hose has an obstruction, use a high pressure water hose to flush the tank or hose. Put the water hose into the drain hose.
4. Leave the tanks and the drain valves open to dry in the air.
5. Check the squeegee blade. Use a cloth to clean the squeegee blade. If the squeegee blade is damaged or worn, turn or replace the blade.
6. Check and clean the solution lid gasket. Use a mild cleaning solution and rinse the parts in clean water.

Check the batteries and add distilled water as needed. The correct level is within 1/4 inch of the bottom of the tube in each cell.

CAUTION: Tap water may contain contaminants that will damage batteries. Batteries must be re-filled with distilled water only.

WARNING: Lead acid batteries generate gases which can cause an explosion. NO SMOKING. Always wear eye protection and protective clothing when working near batteries.

Use a clean cloth and wipe the surface of the machine.

Charge the batteries. See the instruction in the section of this book called "How To Charge The Batteries".

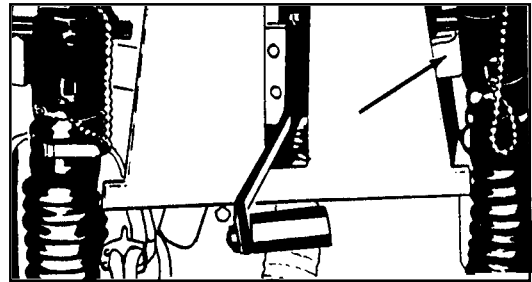

Figure #22a

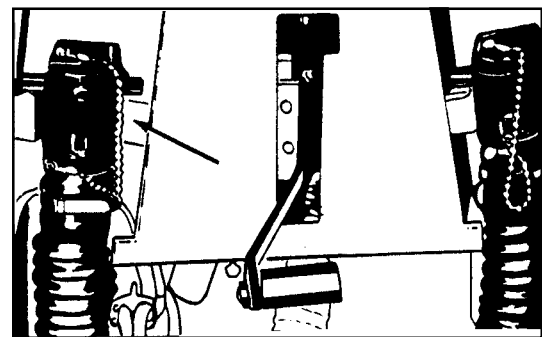

Figure #22b

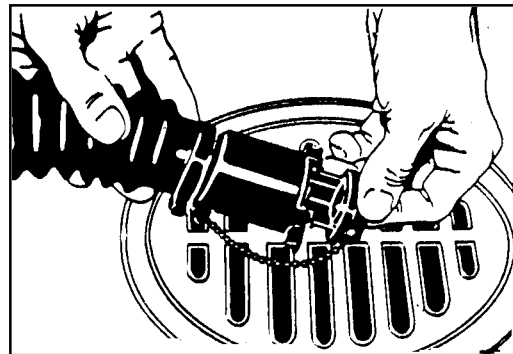

Figure #22c

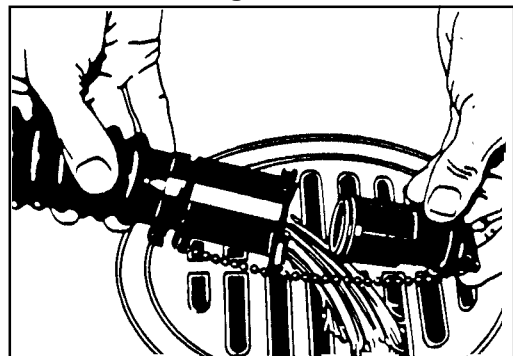

Figure #22d

MAINTENANCE

These Maintenance Procedures Must Be Done Every Week:

⚠ WARNING: Maintenance and repairs must be done by authorized personnel only. Always empty the solution tank and the recovery tank before doing any maintenance. Keep all fasteners tight.

⚠ WARNING: Always wear eye protection and protective clothing when working near batteries. Do not put tools or other metal objects across the battery terminals or the tops of the batteries.

⚠ CAUTION: To prevent damage to the machine, and discharge across the tops of the batteries, do not fill the batteries above the bottom of the tube in each cell. Wipe any acid from the machine or the tops of the batteries. Do not add acid to battery after installation.

NOTE: Always engage the parking brake before servicing the machine.

⚠ WARNING: Always wear eye protection and protective clothing when working near batteries. **NO SMOKING!**

1. To inspect batteries, tip up recovery tank and pull out the stop pin to hold the tank up. See Figure #23
2. Disconnect the batteries. Use a cloth and a solution of ammonia or bicarbonate of soda to wipe the top of the batteries. Clean the battery terminals. Reconnect the batteries.
3. Check the hoses for leaks, obstructions and other damages.
4. Check and clean the filter screen in the solution hose. To clean the screen, follow this procedure:
 - a. Turn the connector to the left.
 - b. Remove and clean the filter screen.
 - c. Install the filter screen in the hose. Turn the connector to the right to connect the hose.
5. Use a grease gun to lubricate the drive wheel and the casters. See figure #24.
6. Apply a thin lubricant to the drive chain.

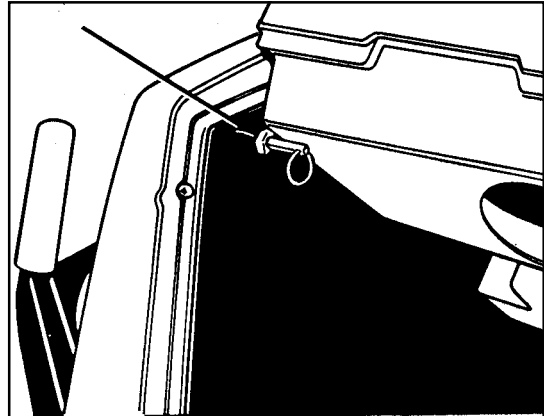

Figure #23

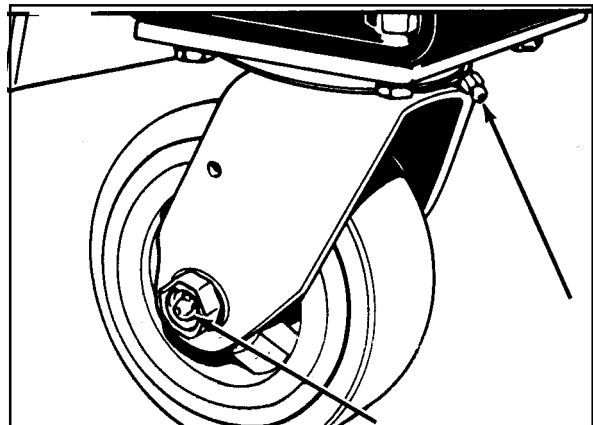

Figure #24

MAINTENANCE

7. Check the squeegee and the scrub brushes or the pad drivers for damage.
8. Check the squeegee and the vacuum hose for damage, leaks and obstructions.

Maintenance For The Squeegee

To remove the squeegee, follow this procedure:

1. Remove the squeegee assembly by loosening the two knobs that attach the squeegee to the machine. Pull the squeegee assembly off. See figure #25.
2. Inspect the squeegee blade.
3. If the blade is worn, turn the blade so that a new edge is in the wiping position.
4. Reinstall squeegee assembly on the machine.

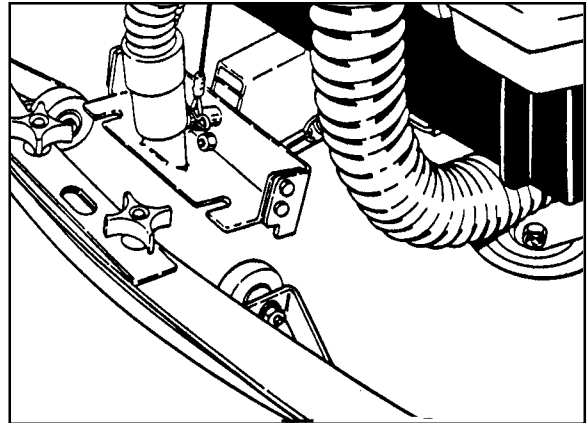

Figure #25

How To Adjust The Squeegee

The following adjustments are set at the factory, however they may require slight adjustment.

Adjusting Squeegee Pressure:

To adjust the pressure, refer to Figure #26. Proper adjustment will produce a uniform flare along the rear blade when the machine is moved forward. To increase pressure, tighten the nuts on each side of the swing arm. To decrease the pressure, loosen the nuts on each side.

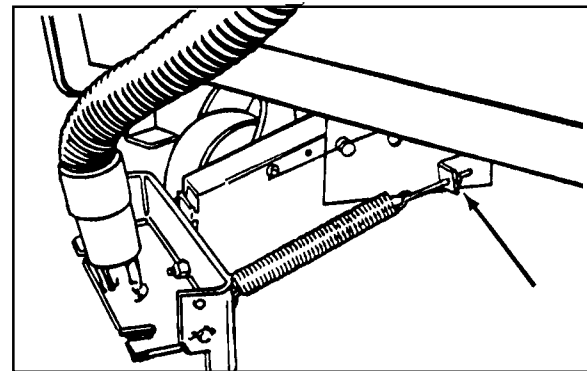

Figure #26

Adjusting Squeegee Tilt:

The tilt of the squeegee causes the rear blade to raise up in the center or on the ends, depending on which direction the tilt is changed. For tilt adjustment, refer to figure # 27. Loosen left and right screw "X". In order to bring the rear blade down in the center, tip "Y" down. To bring both ends down, tip "Y" up. Make very small adjustments and try it until a uniform flare is achieved. Changing the tilt may also require readjusting the squeegee pressure.

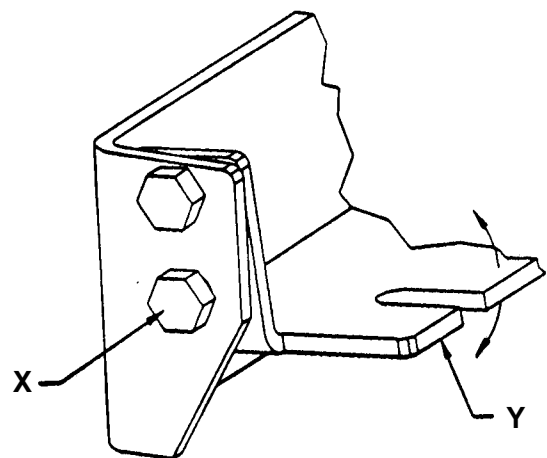

Figure #27

MAINTENANCE

Adjusting Squeegee Blades:

When properly installed the front blade should be approximately .06 above the rear blade. See figure #28.

Adjusting Squeegee Support Wheels:

The support wheels should be set at .12 above the floor with the rear blade touching the floor. See figure #28.

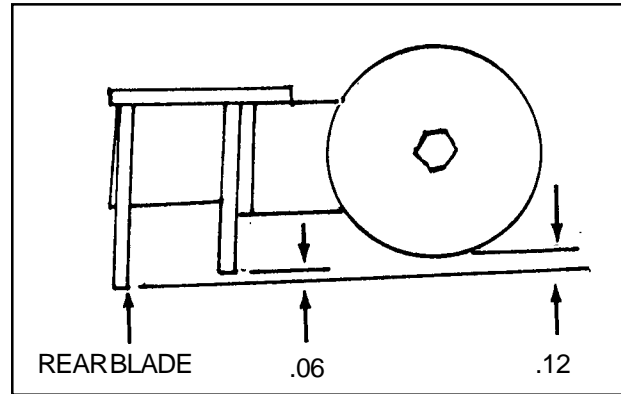

Figure #28

⚠ WARNING: Maintenance and repairs must be done by authorized personnel only .

⚠ WARNING: Electrical repairs must be done by authorized personnel only.

Consult your Clarke Technology Authorized Service Person to do the service procedures.

Use only genuine Clarke Technology parts.

How to Clean the Solution Line

If the solution line becomes clogged, pull the filter assembly out from the lower rear of the frame (Figure #29) and remove the filter screen (Figure # 30) and clean or replace it. Push filter assembly back inside frame.

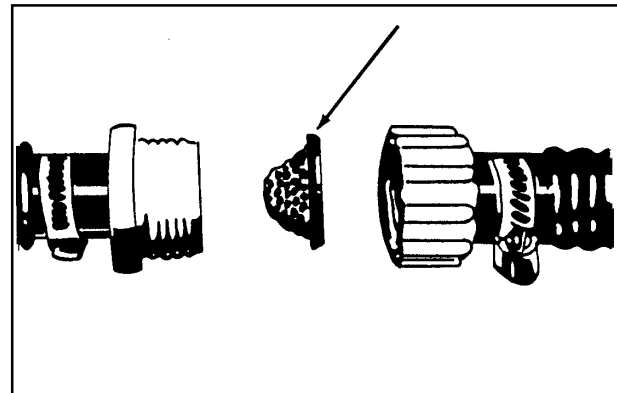

Figure #29

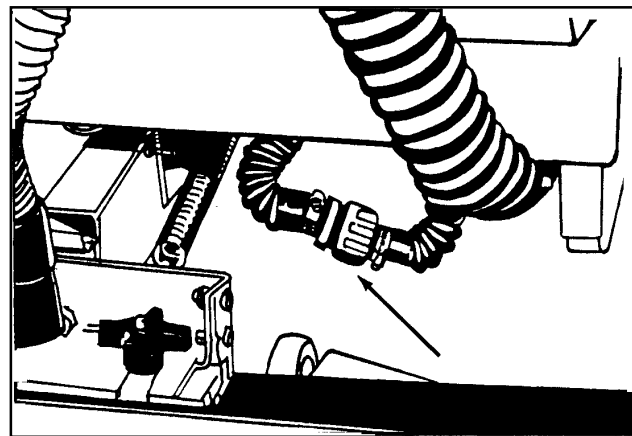

Figure #30

CLARKE TECHNOLOGY Vision 21i /Vision V
Accessories - 11/95

Accessories:

<u>Description</u>	<u>Part No.</u>
Power Wand System Kit	14634A
ESP Recycle System Kit	14633A
Soft Caster (Wheel only)	52127A
Soft Traverse Wheel	59952A
Low Voltage Shut-off (24v)	14097A
Clarke Technology Care Kit	14607A
Frame Bumper	821203
Roller Kit (one side per Kit)	14693A

Nitrile Squeegee Blades:

<u>Length</u>	<u>Machine</u>	<u>Part No.</u>
28.12"	21i	30938A
32.50"	Vision V	30949A

Ribbed Squeegee Blades:

<u>Length</u>	<u>Machine</u>	<u>Part No.</u>
29.88"	Vision V	30948A
25.88"	21i	30942A

Brush Assemblies:

<u>Size</u>	<u>Description</u>	<u>Part No.</u>
11"	Poly	11442A
11"	Grit- Heavy	11443A
11"	Grit-Medium 11444A	
11"	Soft-Nylon	11441A
13"	Poly	11438A
13"	Grit-Heavy	11440A
13"	Grit-Medium 11439A	
13"	Soft Nylon	11437A

Pad Drivers:

<u>Size</u>	<u>Part No.</u>
11"	17530A
13"	17531A

CILARKE TECHNOLOGY Vision 211 / Vision V
Rear Cover Assembly Drawing 7/99

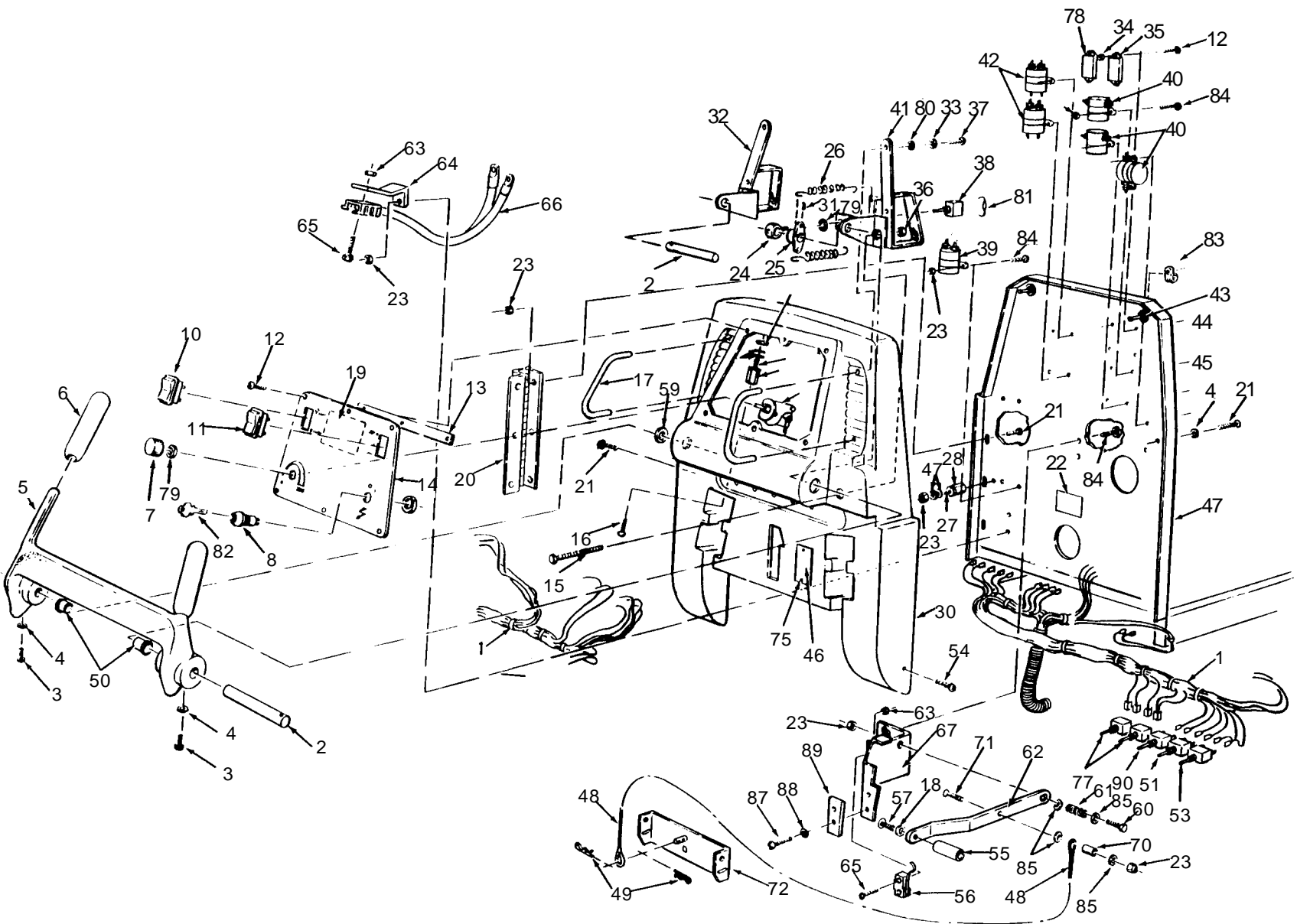

**CLARKE TECHNOLOGY Vision 21i / Vision V
Rear Cover Assembly Parts List 7/99**

Ref #	Part No.	Description	Qty			Ref #	Part No.	Description	Qty		
				Vision 21i	Vision V					Vision 21i	Vision V
1	49720A	Main Harness	1	x	x	43	831105	Tank stop Brushing	2	x	x
2	66533A	Handle Pin	2	x	x	44	836707	Pin	2	x	x
3	85390A	Screw, ¼-20 x 1¼ PN	2	x	x	45	920280	Nut, 5/8-18	2	x	x
4	980657	Washer, Lock 1/4	2	x	x	46	73714A	Warning Plate	1	x	x
5	24308A	Control Handle	1	x	x	47	63342A	Frame Weldment	1	x	x
6	34608A	Control Handle Grip	2	x	x	48	61653A	Squeegee Lift Cable	1	x	x
7	962262	Screw, 8-32 x ¼ Set	2	x	x	49	856702	Hairpin	2	x	x
8	47380A	Key Switch, W/Key	1	x	x	50	902731	Nyliner Bushing	2	x	x
9	55502A	Knob	1	x	x	51	41448A	Circuit Breaker, 30A (Vac)	1	x	x
10	47381A	Switch (Head Up/Down)	1	x	x	53	41423A	Circuit Breaker, 5A (Hd. Act.)	1	x	x
11	47383A	Switch (3 Speed Trav.)	1	x	x	54	85518A	Screw, ¼-20 x ¾ PN	5	x	x
12	962966	Screw, 10-24 x ¾ PN	6	x	x	55	64490A	Handle	1	x	x
13	34264A	Gasket	2	x	x	56	47388A	Switch Asm., Vac	1	x	x
14	69339B	Console Panel	1	x	x	57	85389A	Screw, 3/8-16 x 5/8 PN	1	x	x
15	80011A	Screw, 3/8-16 x 3 CR	2	x	x	59	87029A	Washer, Flat ¾	1	x	x
16	85395A	Screw, ¼-20 x ½ PN	1	x	x	60	80028A	Bolt	1	x	x
17	64462A	Stationary Handle	2	x	x	61	438360	Spring	1	x	x
18	980666	Washer, Starlock 3/8	1	x	x	62	65619A	Squeegee Lift Lever	1	x	x
19	77208A	Wiring Label	1	x	x	63	920056	Nut, 6-32 ESNA	4	x	x
20	64508A	Cover Hinge	1	x	x	64	60676A	Power, Conn. Bracket	1	x	x
21	85391A	Screw, ¼-20 x 5/8 PN	8	x	x	65	962980	Screw, 6-32 x 1 PN	4	x	x
22	77211B	Wiring Label	1	x	x	66	41146A	Console Cable Assembly	1	x	x
23	81104A	Nut, ¼-20 ESNA	20	x	x	67	61260A	Squeegee Lift Bracket	1	x	x
24	61651A	Control Switch Collar	1	x	x	70	608210	Spacer	1	x	x
25	60662A	Centering Bracket	1	x	x	71	962285	Screw, ¼-20 x 1 Flat	1	x	x
26	53038A	Spring	2	x	x	72	Pg. 28	Pin Bracket ref. #25	1	x	x
27	83302A	Stud	2	x	x	74	980651	Washer, Flat 5/16	1	x	x
28	854849	Insulator	2	x	x	75	930093	Rivet	2	x	x
29	61652A	Solution Control	1	x	x	77	41431A	Circuit Breaker 35A (Br. Mtr.)	1	x	x
30	30024A	Rear Cover	1	x		78	46317A	Relay, 3 sec. (HSD)	1	x	x
31	962304	Screw, 5/16-18 x ½ Set	4	x	x	79	87202A	Washer, Lock	1	x	x
32	69507A	Cover Support, LH	1	x	x	80	980205	Washer	4	x	x
33	980652	Washer, Lock 5/16	4	x	x	81	42404A	Diode Asm.	1	x	x
34	920296	Nut, 10-24 ESNA	2	x	x	82	55413A	Key	1	x	x
35	46318A	Relay- .12 Sec. (F/N/R)	1	x	x	83	51867A	Clamp, Cable	1	x	x
36	81301A	Nut, 3/8-16 Jam	2	x	x	84	170915	Screw, ¼-20 x ¾ Hex	16	x	x
37	85813A	Screw, 5/16-18 x ¾ HX	4	x	x	85	87026A	Washer, Flat ¼	8	x	x
38	10052A	Toggle Switch (Traverse)	1	x	x	86	85700A	Screw ¼-20 x 1 Hex	2	x	x
39	41810A	Solenoid, Brush Motor	1	x	x	87	962546	Screw, #10-24 X ½	2	x	x
40	878514	Solenoid, Vac, Speed Ctrl	3	x	x	88	980675	Washer	2	x	x
41	69506A	Cover Support, RH	1	x	x	89	68643A	Plate, Wear	1	x	x
42	41811A	Solenoid, For./Rev.	2	x	x	90	41444A	Circuit Breaker 30A (Trav.)	1	x	x

CLARKE TECHNOLOGY Vision 21i - Vision V
Traverse System Assembly Drawing 2/00

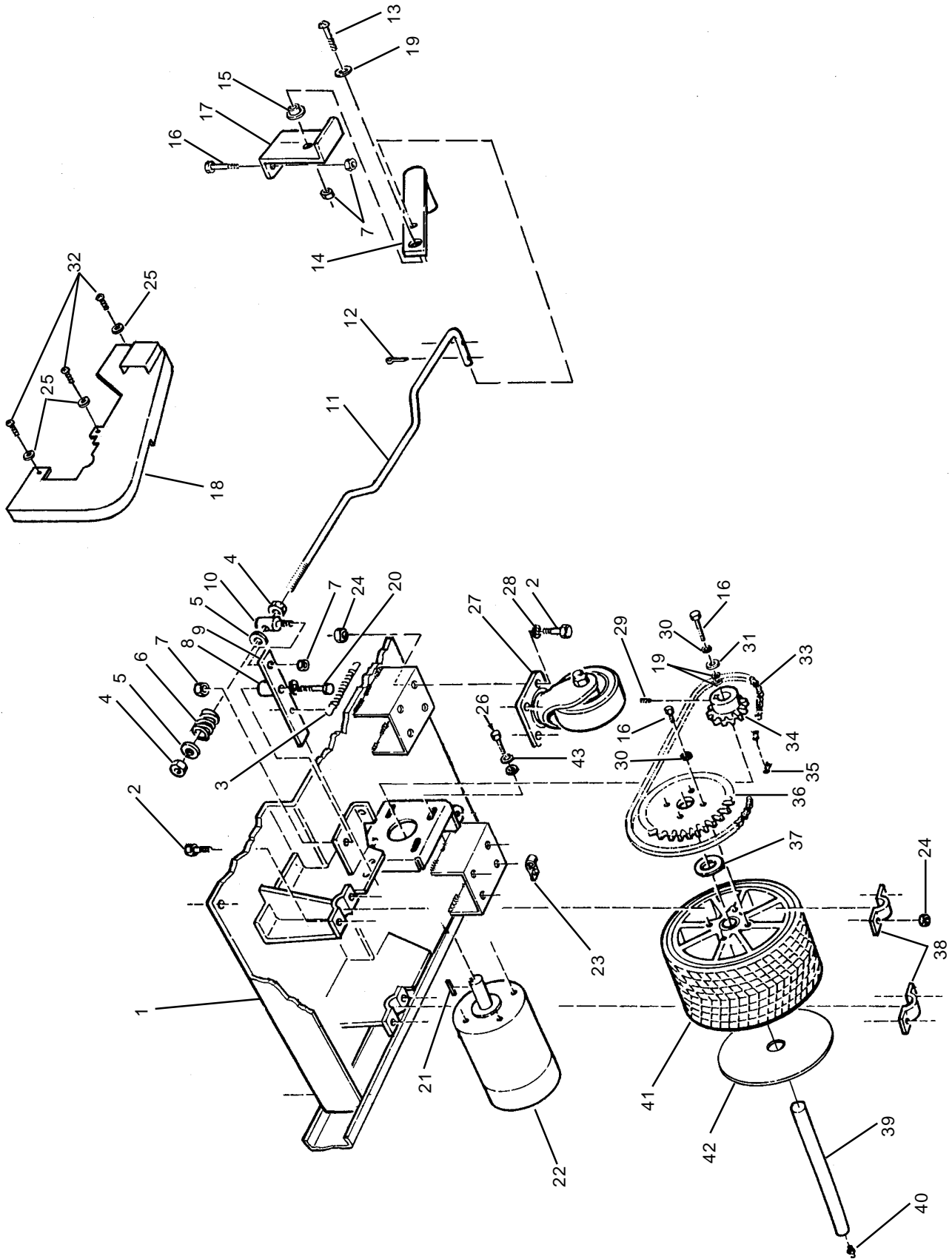

**CLARKE TECHNOLOGY Vision 21i - Vision V
Traverse System Assembly Parts List 2/00**

Ref #	Part No.	Description	Qty	Vision V Vision 21i
1	63342A	Frame	1	x x
2	85727A	Screw, $\frac{3}{8}$ -16 x 1 Hex	12	x x
3	848302	Brake Spring	1	x x
4	81104A	Nut, $\frac{1}{4}$ -20 Hex ESNA	4	x x
5	87026A	Washer, Flat $\frac{1}{4}$	5	x x
6	438360	Spring	1	x x
7	920110	Nut, $\frac{5}{16}$ -18, ESNA	3	x x
8	838214	Brake Arm Spacer	1	x x
9	60412A	Brake Arm	1	x x
10	848508	Brake Rod Swivel	1	x x
11	67147A	Brake Rod	1	x x
12	925004	Cotter Pin	2	x x
13	85814A	Screw, $\frac{5}{16}$ -18 x 1.25 Hx	1	x x
14	16703A	Brake Lever	1	x x
15	67877A	Brake Pedal Spacer	1	x x
16	85811A	Screw, $\frac{5}{16}$ -18 x $\frac{3}{4}$ Hex	5	x x
17	60663A	Brake Pedal Bracket	1	x x
18◆	60246A	Guard	1	x x
19	980651	Washer, Flat $\frac{5}{16}$	3	x x
20	85816A	Screw, $\frac{5}{16}$ -18 x 1.5 Hx	1	x x
21	915102	Key	1	x x
22	45038A	Traverse Motor	1	x x
23	51828A	Strap	1	x x
24	81105A	Nut, $\frac{3}{8}$ -16 ESNA	12	x x
25◆	170892	Washer, Lock $\frac{1}{4}$	7	x x
26	170915	Screw, $\frac{1}{4}$ -20 x $\frac{3}{4}$	4	x x
27	899769	Caster Assembly	2	x x
28	980638	Washer, Lock $\frac{3}{8}$	8	x x
29	962593	Screw, $\frac{1}{4}$ -20 x $\frac{3}{8}$ set	2	x x
30	980652	Washer, Lock $\frac{5}{16}$	5	x x
31	980205	Washer	1	x x
32◆	85395A	Screw, $\frac{1}{4}$ -20 x $\frac{1}{2}$	3	x x
33	52202A	Chain	1	x x
34	898550	Drive Sprocket	1	x x
35	895158	Master Link	1	x x
36	838506	Driven Sprocket	1	x x
37◆	980475	Spacer Washer	3	x x
38	69009A	Axle Strap	2	x x
39	60154A	Shaft	1	x x
40	883351	Grease Fitting	1	x x
41	59944R	Wheel Assembly	1	x x
42◆	30063A	Sheild, Wheel Guard	1	x x
NI◆	77266B	Label, Parking Brake	1	x x

NOTE: ◆ indicates a change has taken place since last publication of this manual

CLARKE TECHNOLOGY Vision 21i - Vision V
Squeegee & Squeegee Arm Assembly Drawing 1/97

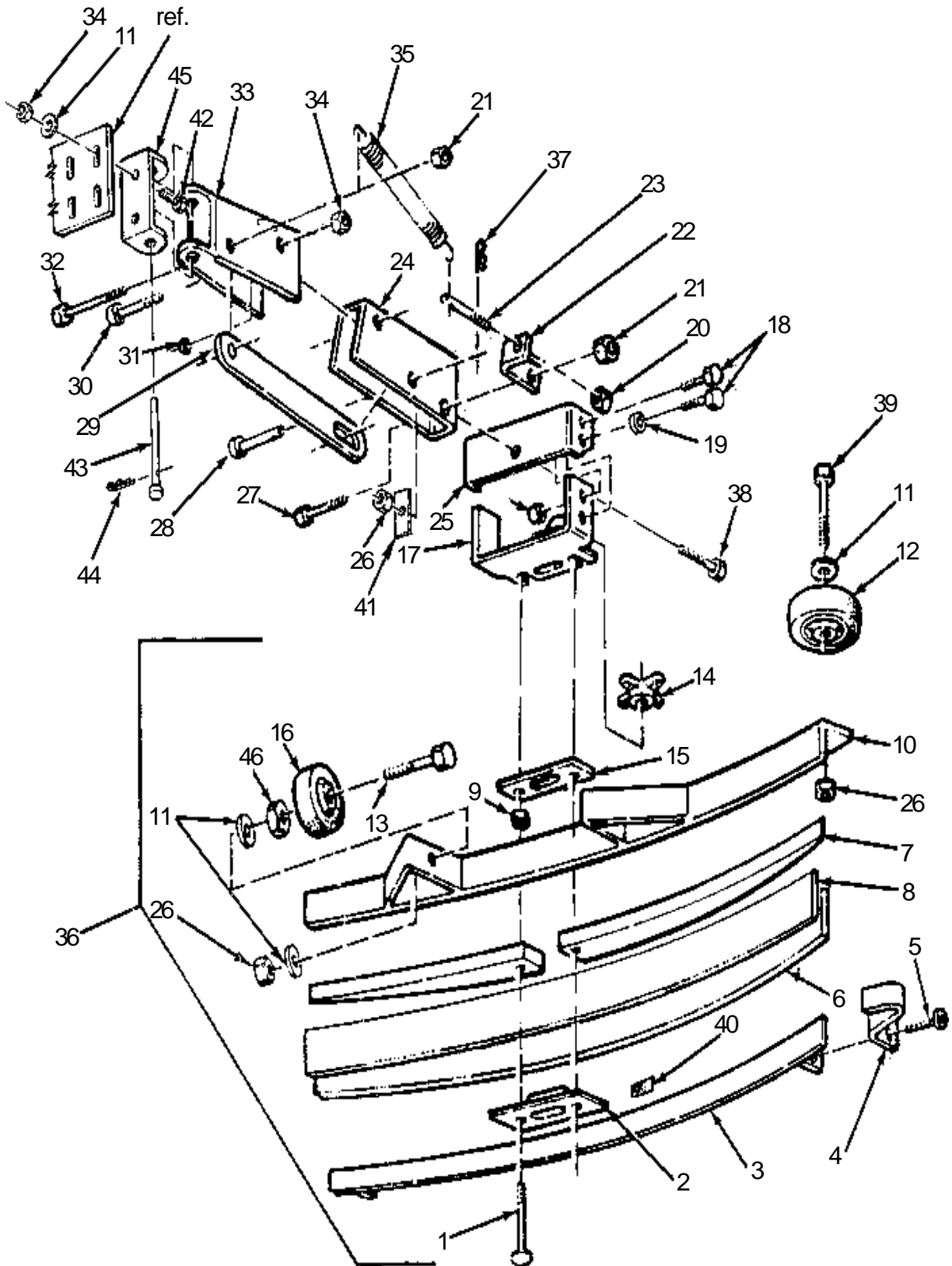

**CLARKE TECHNOLOGY Vision 21i - Vision V
Squeegee & Squeegee Arm Assembly Parts List 1/97**

Ref #	Part No.	Description	Qty	Version 21i Version V
1	80011A	Screw, 3/8-16 x 3 CR	2	x x
2	62712A	Duct	1	x x
3	62430A	Clamp Weld	1	x
	62424A	Clamp Weld	1	x
4	62421A	End Clamp	2	x x
5	86004A	Screw, 1/4-20 x 1.50 Hx	2	x x
6	30946A	Outer Blade	1	x
	30931A	Outer Blade	1	x
7	38719A	Spacer	2	x
	38713A	Spacer	2	x
8	30947A	Inner Blade	1	x
	30930A	Inner Blade	1	x
9	81301A	Nut, 3/8-16 JAM	6	x x
10	69613A	Squeegee Weld.	1	x
	69059A	Sq. Weld.	1	x
11	980687	Washer 3/8 ID	11	x x
12	59950A	Guide Wheel	2	x x
13	962522	Screw, 3/8-16 x 1.50 Hex	2	x x
14	25201A	Knob	2	x x
15	34260B	Squeegee Gasket	1	x x
16	419702	Wheel	2	x x
17	61242A	Tube Bracket	1	x x
18	170915	Screw, 1/4-20 x 3/4 Hex	4	x x
19	87026A	Washer, Flat 1/4	5	x x
20	920256	Nut, 5/16-18 Hex	2	x x
21	81104A	Nut, 1/4-20 Hex ESNA		x x
22	60659A	Squeegee Spring Brkt.	2	x x
23	68013A	Squeegee Adj. Stud	2	x x
24	60417A	Rear Arm	1	x x
25	61249A	Pin Bracket	1	x x
26	81105A	Nut, 3/8-16 ESNA	5	x x
27	962269	Screw, 1/4-20 x 2.50 Hex	1	x x
28	82505A	Squeegee Actuator Pin	1	x x
29	63009A	Squeegee Lift Bar	1	x x
30	80015A	Shoulder Bolt	1	x x
31	920056	Nut, 6-32 ESNA	4	x x
32	962920	Screw, 1/4-20 x 3.4 Soc.	1	x x
33	60420A	Front Arm	1	x x
34	920110	Nut, 5/16-18 ESNA	5	x x
35	56493A	Squeegee Press. Spring	2	x x
36	18810A	Squeegee Asm.	1	x
	18807A	Squeegee Asm.	1	x
37	836711	Hairpin	3	x x
38	85727A	Screw, 3/8-16 x 1 Hwx	1	x x
39	85704A	Screw, 3/8-16 x 2 1/4	2	x x
40	37016A	Pad	1	x x
41	67899A	Washer, Flat 3/8 S.S.	1	x x
42	85811A	Screw 5/16 - 18 x .75	2	x x
43	66531A	Swing Arm Pin	1	x x
44	836711	Hair Pin	1	x x
45	60416A	Arm, Pivot	1	x x
46	81207A	Nut, 3/8-16 SS	2	x x

CLARKE TECHNOLOGY Vision 21i - Vision V
Brush Head Assembly Parts List 9/98

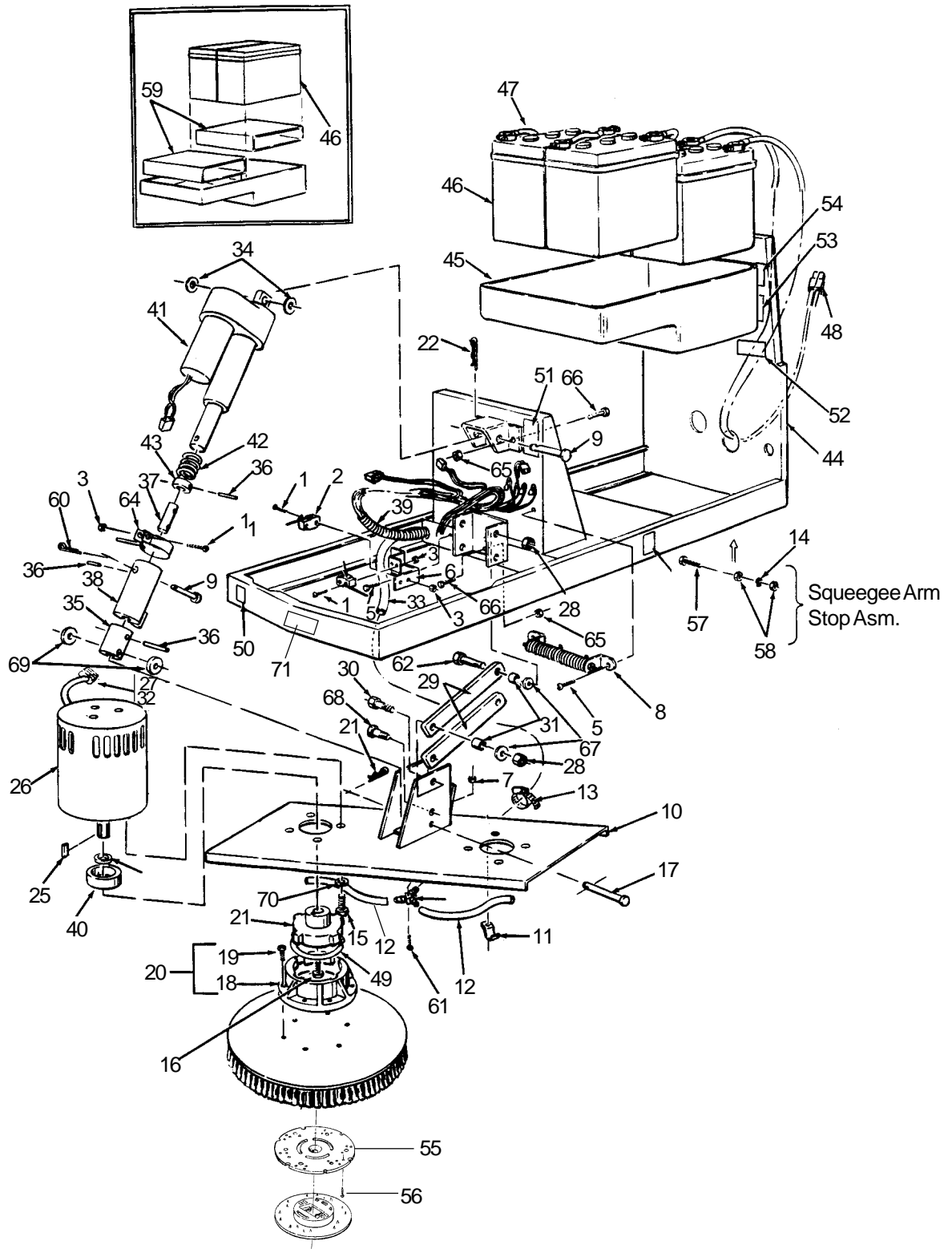

**CLARKE TECHNOLOGY Vision 21i - Vision V
Brush Head Assembly Parts List 9/98**

Ref #	Part No.	Description	Qty	Vision 21i Vision V
1	962980	Screw, 6-32 x 1 PN	4	x x
2	47374A	Lever Switch (Scrub Lmt.)	1	x x
3	920056	Nut, 6-32 ESNA	6	x x
4	47405A	Switch, Brush (Head Up)	1	x x
5	85519A	Screw, ¼-20 x ¾ PN	4	x x
6	69434A	Switch Bracket	1	x x
7	81104A	Nut, ¼-20 ESNA	2	x x
8	46508A	Resistor (Traverse Res.)	1	x x
9	82501A	Pin	2	x x
10	68661A	Brush Plate	1	x
	68670A	Brush Plate	1	x
11	782002	Clamp	2	x x
12	34705A	Brush Hose L.H. & R.H.	2	x
	34704A	Brush Hose L.H. & R.H.	2	x
13	722030	Hose Clamp	1	x x
14	980638	Washer, Lock ¾	8	x x
15	170915	Screw, ¼-20 x ¾	8	x x
16	962714	Screw, 5/16-18 x ¾ Soc	2	x x
17	82508A	Pin	1	x x
18	833802	Gimbal	2	x x
19	962495	Screw, ¼-20 x 1 Pn	6	x x
20	Pg 23	Brushes & Pads	2	x x
21	34400B	Gimbal	2	x x
22	836711	Hairpin	3	x x
23	838502	Splitter, Water	1	x x
25	915102	Key	1	x x
26	45037A	Motor, Brush (ref. to pages 36 & 37)	2	x x
27	41601A	Connector	2	x x
28	920365	Nut, ½-13 ESNA	8	x x
29	63058A	Linkage Bar	4	x x
30	962344	Screw, ½-13 x 1¼ HX	2	x x
31	67705B	Sleeve Bearing	8	x x
32	41602A	Connector Housing	2	x x
33	Pg. 33	Solution Hose ref. #4	1	x x
34	38708A	Nylon Washer	2	x x
35	67703A	Head Pressure Sleeve	1	x x
36	82404A	Spirol Pin, 3/16	3	x x

Ref #	Part No.	Description	Qty	Vision 21i Vision V
37	66530A	Head Pressure Pin	1	x x
38	69100B	Head Pressure Tube	1	x x
39	49720A	Harness, Wiring	1	x x
40	61658A	Gimbal Collar	2	x x
41	50204A	Actuator	1	x x
42	53400A	Head Pressure Spring (ref. to pages 36 and 37)	1	x x
43	69006A	Spring Seat	1	x x
44	63342A	Main Frame	1	x x
45	39007B	Battery Tray	1	x x
46	871334	Battery, 12 Volt, 195 AH	2	x x
	881317	Battery, 6 Volt, 250 AH	4	x x
47	842406	Series Cable-9"	1	x x
	41206A	Series Cable-16"	2	x x
48	41211A	Battery Cable	1	x x
49	838301	Brush Holder Spring	2	x x
50	77091A	Label, Warning-Moving	3	x x
51	77210A	Label, Wiring	1	x x
52	77209A	Label, Battery Connect.	1	x x
53	77092A	Label, Warning-Battery	2	x x
54	77093A	Label, Warning-Falling	2	x x
55	56941A	Center Lok Asm. (Pad Driver only)	2	x x
56	962737	Screw #10-16x7/8 (pad driver only)	6	x x
57	80011A	Screw 3/8-16 x 3 CR	2	x x
58	81301A	Nut, 3/8-16 JAM	4	x x
59	67887A	Spacer, 12V Bat.	2	x x
60	925006	Cotter Pin	1	x x
61	962989	Screw, ¼-20 x 1½	2	x x
62	962850	Screw, ½-13 x 1½ Hx	4	x x
63	59856A	Washer, Rubber	2	x x
64	60509A	Activator	1	x x
65	81105A	Nut, 3/8-16 ESNA	4	x x
66	85727A	Screw 3/8-16 x 1	4	x x
67	980673*	Washer	8	x x
68	85735A	Screw, Special Hd	2	x x
69	81216A	Nut, Spacer	2	x x
70	170892	Washer, Lock ¼	8	x x
71	70065A	Label 26v	1	- x
	70066A	Label, 21i	1	x -

*NOTE: #67 used with screws #62 only as needed to square up linkage bars #29.

CLARKE TECHNOLOGY Vision 21i - Vision V
 Solution/Vacuum System Drawing 9/98

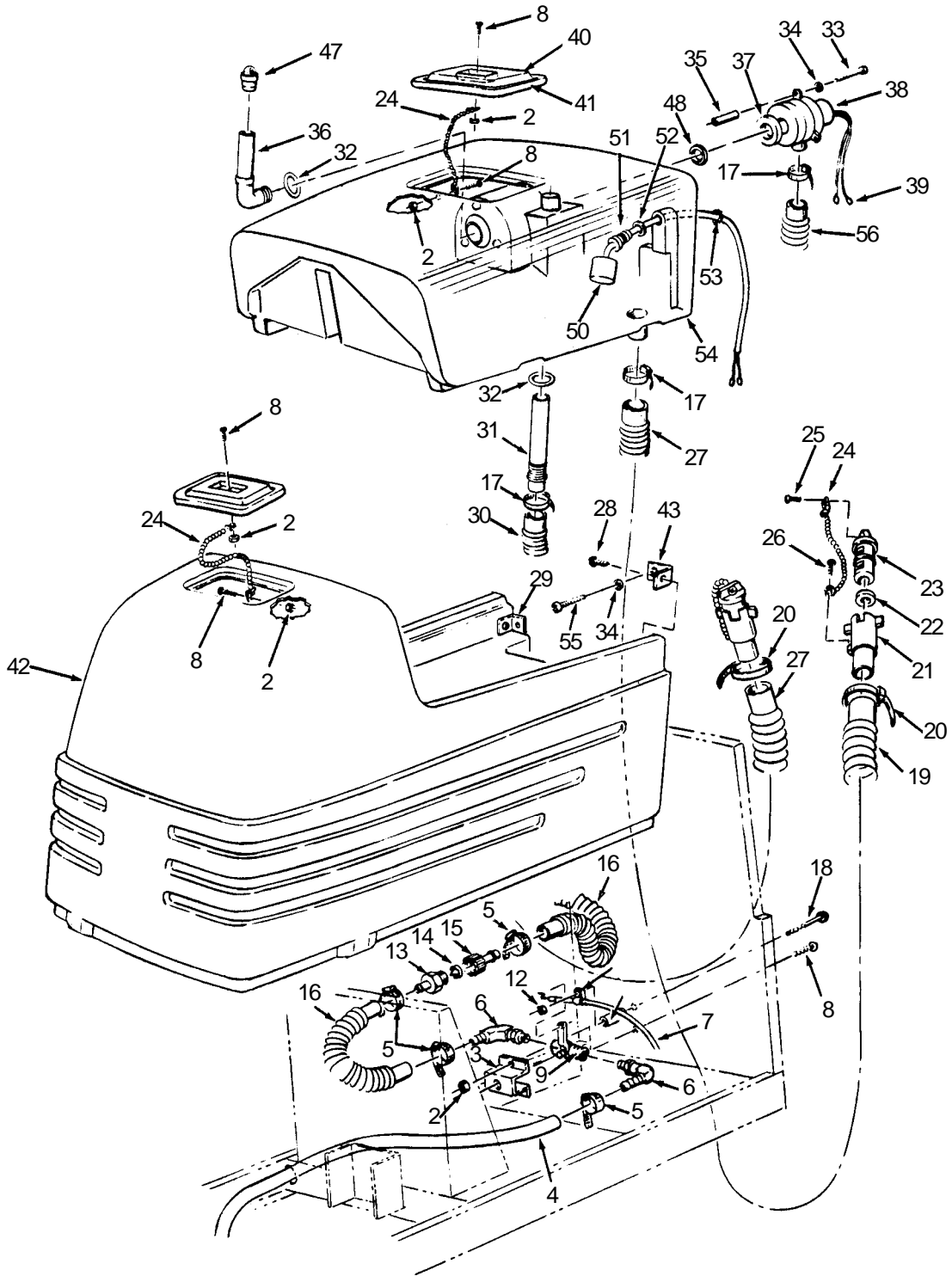

**CLARKE TECHNOLOGY Vision 21i - Vision V
Solution/Vacuum System Parts List 9/98**

Ref #	Part No.	Description	Qty	Vision 21i Vision V
2	920296	Nut, 10-24 ESNA	6	x x
3	820823	Bracket	1	x x
4	35199A	Solution Hose	1	x x
5	722030	Hose Clamp	6	x x
6	822802	Elbow	2	x x
7	61652A	Solution Control	1	x x
8	962798	Screw, 10-24 x 1/2 Pan	6	x x
9	849401	Solution Valve	1	x x
10	678215	Spacer	1	x x
11	832102	Cable Clip	1	x x
12	81104A	Nut, 1/4-20 ESNA	1	x x
13	830214	Connector	1	x x
14	838517	Filter Screen	1	x x
15	50335A	Hose Adapter	1	x x
16	30412A	Hose	2	x x
17	872010	Hose Clamp	5	x x
18	85702A	Screw, 1/4-20 x 1 3/4	1	x x
19	35102A	Drain Hose, Recovery	1	x x
20	832002	Clamp	2	x x
21	839401	Drain Valve	2	x x
22	833407	Drain Gasket	2	x x
23	833901	Drain Valve Handle	2	x x
24	52206A	Chain	4	x x
25	962987	Screw, 10-24 x 3/8 PN	2	x x
26	962943	Screw, 8-18 x 1/2 PN	2	x x
27	30405A	Drain Hose, Solution	1	x x
28	85391A	Screw, 1/4-20 x 5/8 PN	4	x x

Ref #	Part No.	Description	Qty	Vision 21i Vision V
29	60659A	Bracket	1	x x
30	30409B	Squeegee Hose	1	x x
31	30123A	Squeegee Adapter	1	x x
32	837304	O-Ring	2	x x
33	85728A	Screw, 1/4-20 x 4.00 Hex	3	x x
34	87026A	Washer, Flat 1/4	5	x x
35	58533A	Vac Motor Spacer	3	x x
36	59319A	Stand, Tube	1	x x
37	643418	Gasket	1	x x
38	44917A	Vac Motor	1	x x
39	41809A	Contact	4	x x
	43401A	Housing Black - Vac	2	x x
	43402A	Housing Blue - Float	2	x x
40	832322	Lid	2	x x
41	34256A	Lid Gasket	2	x x
42	38984C	Solution Tank	1	x x
43	69443A	Bracket, Solution Tank LH	1	x x
47	58012A	Vacuum Strainer	1	x x
48	920797	Nut	1	x x
50	14092A	Float Switch	1	x x
51	56459A	Strain Relief	1	x x
52	87612A	Seal	1	x x
53	170686	Locknut	1	x x
54	38985D	Recovery Tank	1	x x
55	170915	Screw, 1/4-20 x 3/4 hex	1	x x
56	30410A	Hose, Vac Motor	1	x x

CLARKE TECHNOLOGY Vision 21i - Vision V
Brush Housing Assembly Drawing 7/96

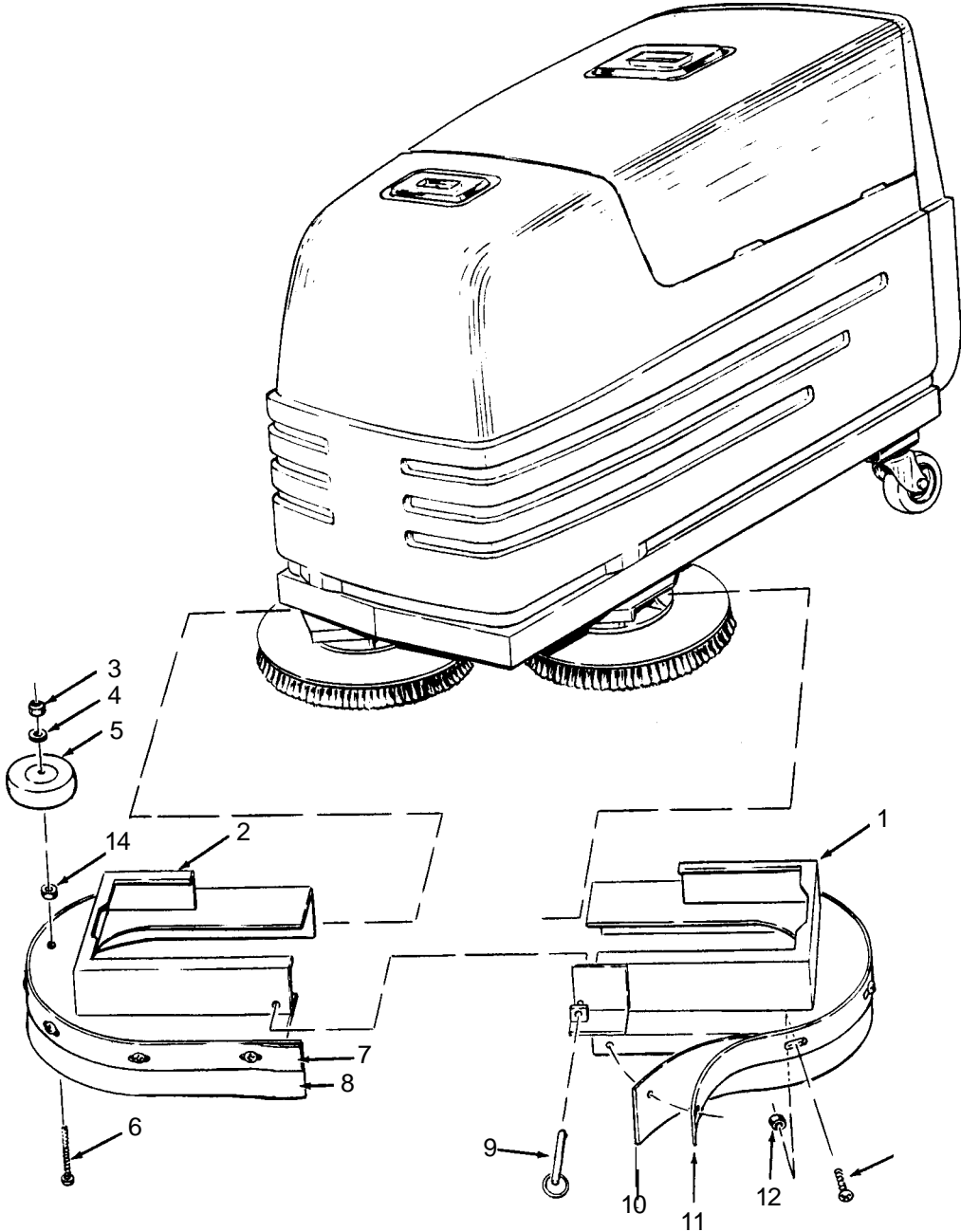

**CLARKE TECHNOLOGY Vision 21i - Vision V
Brush Housing Assembly Parts List 7/96**

Ref #	Part No.	Description	Qty	Vision 21i Vision V
1	64729A	Brush Housing, L.H.	1	x
	64727A	Brush Housing, L.H.	1	x
2	64728A	Brush Housing, R.H.	1	x
	64726A	Brush Housing, R.H.	1	x
3	81105A	Nut, 3/8-16 ESNA	1	x x
4	980687	Washer	1	x x
5	419702	Guide, Wheel	1	x x
6	85704A	Scr., 3/8-16 x 2¼	1	x x
7	69089A	Strap, R.H.	1	x
	69079A	Strap, R.H.	1	x
8	38235A	Skirt, R.H.	1	x
	38234A	Skirt, R.H.	1	x
9	50449A	Pin	1	x x
10	38236A	Skirt, L.H.	1	x
	38233A	Skirt, L.H.	1	x
11	69090A	Strap, L.H.	1	x
	69078A	Strap, L.H.	1	x
12	81104A	Nut, 1/4-20 ESNA	9	x
	81104A	Nut, 1/4-20 ESNA	11	x
13	85737A	Scr., 1/4-20 x 5/8 Hex	9	x
	85737A	Scr., 1/4-20 x 5/8 Hex	11	x
14	81301A	Nut, 3/8-16 Jam	1	x x

**CLARKE TECHNOLOGY Vision 21i - Vision V
Alternate Brush Motor Assembly #44809A 5/95**

NOTICE: If your Vision V or Vision 21i has brush motor #44809A, shown below, use the parts on this page. Refer to pages 30 and 31 in this manual for other parts.

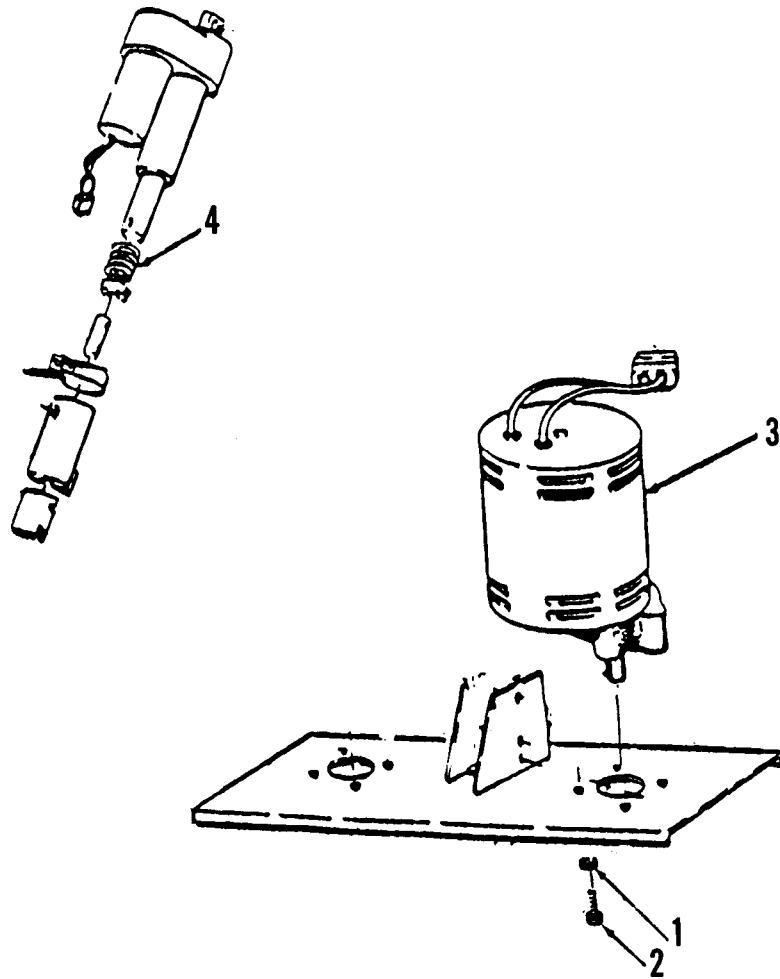

Ref.	Part No.	Description	Qty.
1	980638	Washer, Lock 3/8	8
2	962244	Screw, 3/8-16 x 3/4	8
3	44809A	Motor, Brush	2
4	53412A	Head Pressure Spring	1

**CLARKE TECHNOLOGY Vision 21i - Vision V
Alternate Brush Motor #44809A 5/95**

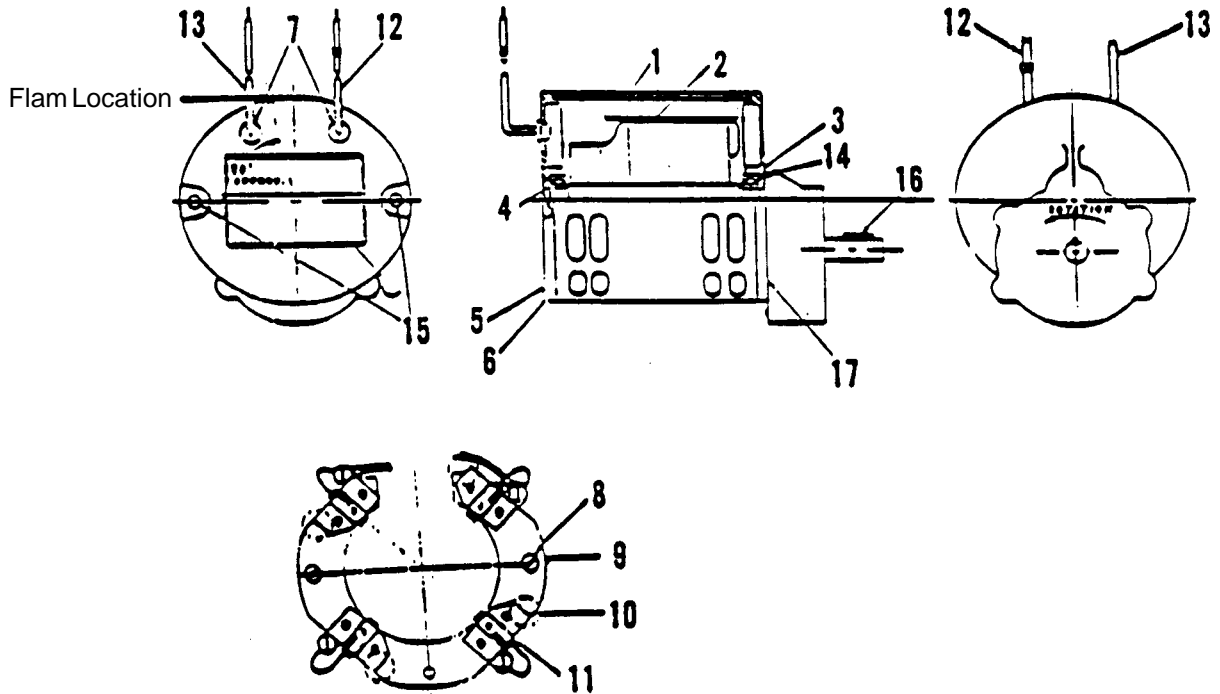

Item	Part No.	Description	Qty
1	56478A	Stator Frame Assembly (w/Magnets & Clips)	1
2	50142A	Armature Assembly (w. B.E. & F.E. Bearings)	1
3	902654	Bearings B.E.	1
4	902550	Bearing F.E.	1
5	51840A	Commutator Bracket Assembly (w/Brush BRD Assembly Leads)	1
6	50520A	Commutator Bracket	1
7	56480A	Strain Relief	2
8	962546	Brush Board Screw	2
9	50517A	Brush Board Assembly (w/ Springs & Brushes)	1
10	448396	Brush Spring	4
11	40826A	Brush Assembly	4
12	55657A	Lead Assembly	1
13	55656A	Lead Assembly	1
14	59805A	Helical Washer	1
15	50515A	Thru Bolt	2
16	44809A	Shaft Key	1
17	54238A	B.E. Bracket Assembly (Gear Box)	1

CLARKE TECHNOLOGY Vision 21i - Vision V
Brush Motor #45037A 3/95

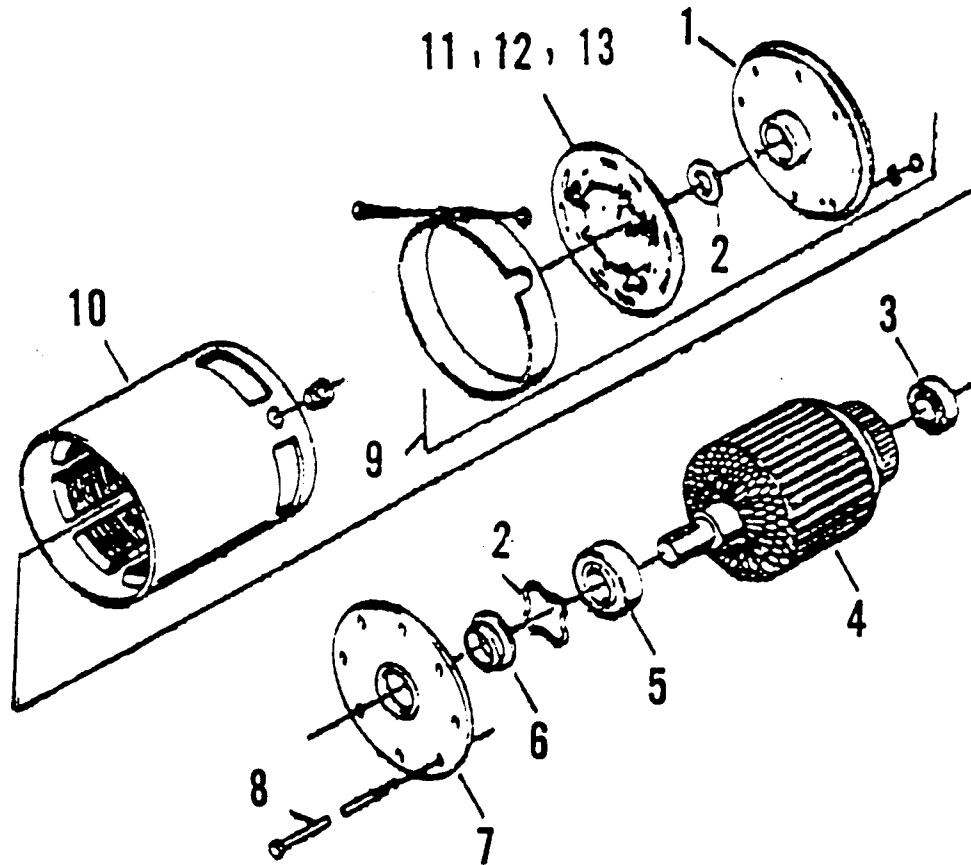

Ref #	Part No.	Description	Qty
1	832315	Com. Bracket Cover	1
2	980076	Washer - Helical	1
3	902547	Bearing	1
4	50156A	Armature Assembly	1
5	902550	Bearing	1
6	897655	Seal - Oil	1
7	830846	Bracket	1
8	962955	Screw ¼-20 x 5¾ Hex	2
9	50577A	Bracket Assembly	1
10	833102	Field Asm. w/Mag Clips	1
11	55133A	Brush Holding Asm.	1
12	448396	Spring-Brush	4
13	40807A	Brush Assembly	4

CLARKE TECHNOLOGY Vision 21i - Vision V
 Traverse Motor #45038A 8/94

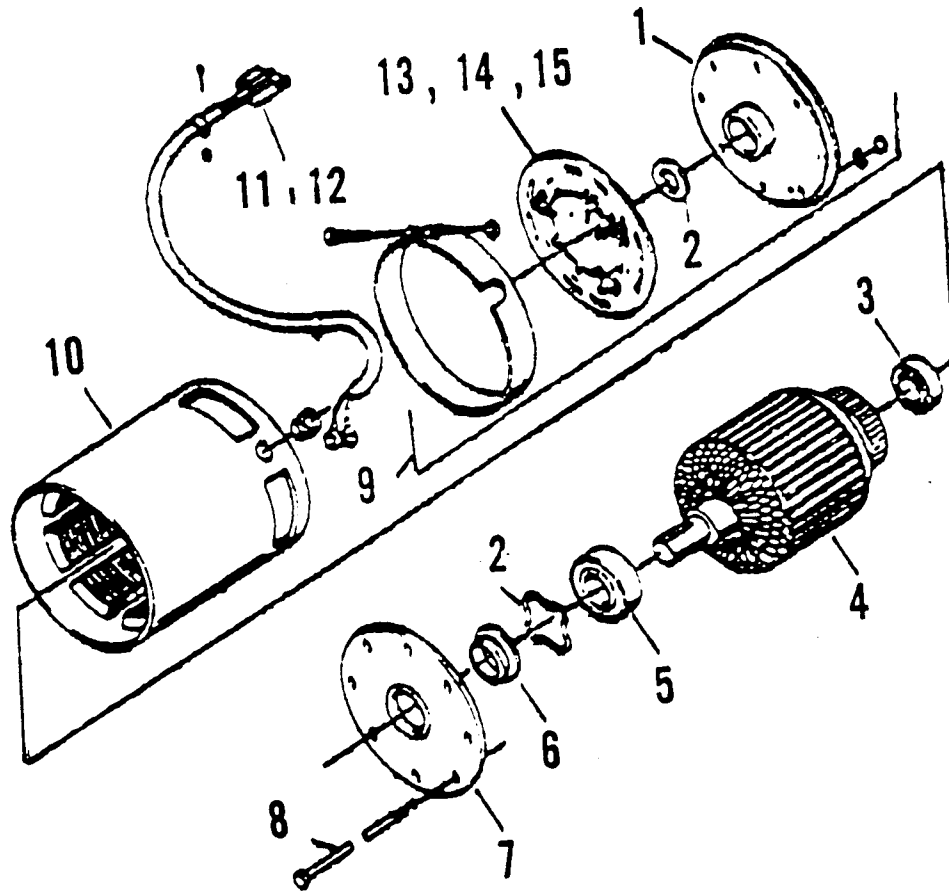

Ref #	Part No.	Description	Qty
1	52776A	Cover, Bracket, Com.	1
2	980076	Washer - Helical	1
3	902547	Bearing	1
4	50156A	Armature Assembly	1
5	902550	Bearing	1
6	897655	Seal - Oil	1
7	830845	Bracket	1
8	962955	Screw ¼-20 x 5¾ Hex	2
9	50577A	Bracket Assembly	1
10	833102	Field Asm. w/Mag Clips	1
11	912206	Housing - Male Terminal Connector	1
12	912207	Terminal - Male	1
13	55133A	Brush Holding Assembly	1
14	448396	Spring-Brush	4
15	40807A	Brush Assembly	4

**CLARKE TECHNOLOGY Vision 21i - Vision V
Battery Charger
Drawing & Parts List 8/94**

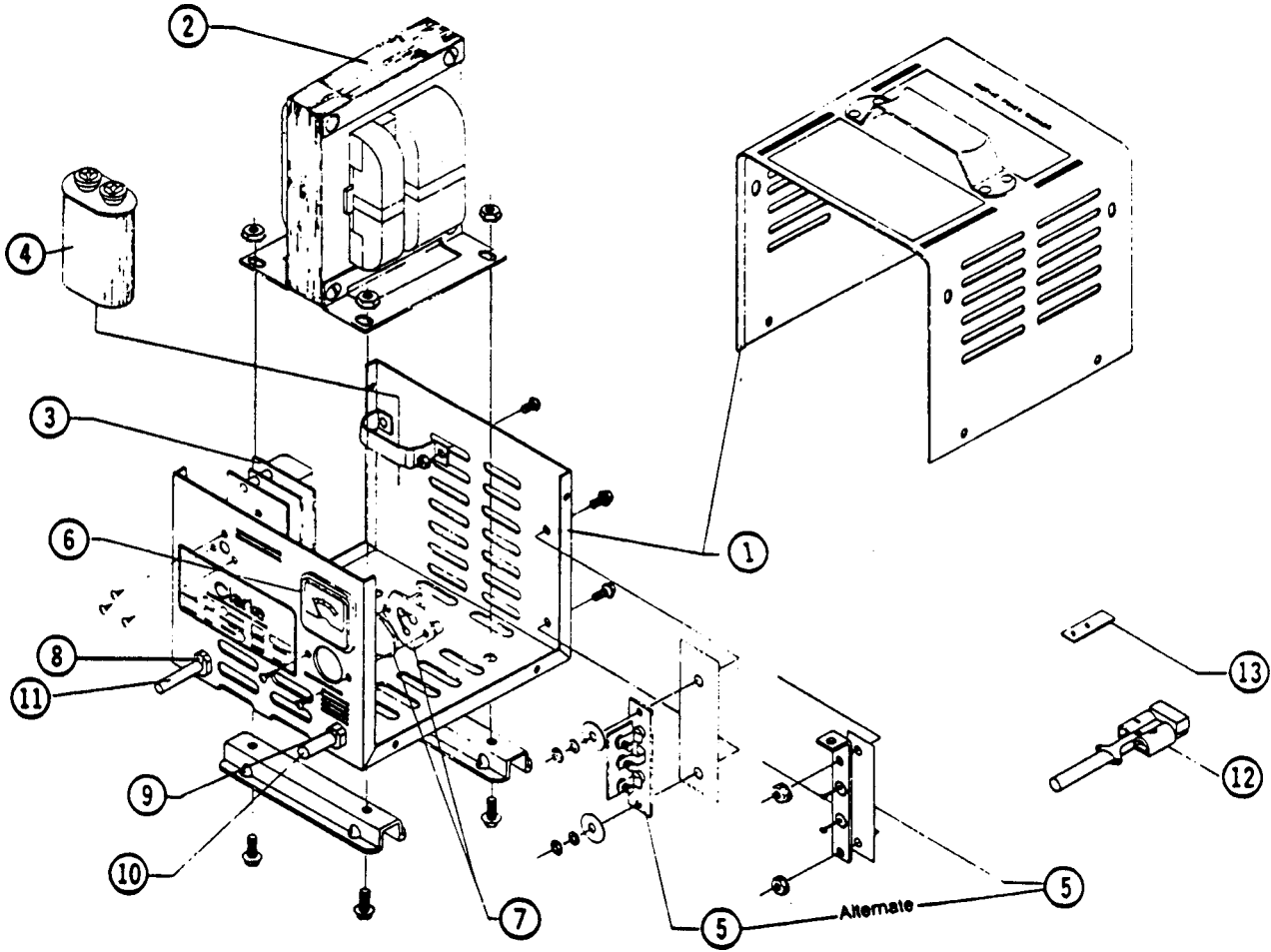

WARNING: All electrical repairs must be performed by qualified personnel only.

Charger #40512A: 24 volt, 25 amp D.C., 115 volt, A.C., 60 Hz
 Charger #40513A: 24 volt, 25 amp D.C., 230 volt, A.C., 50 Hz

Ref #	Description	Charger Model Number	
		40512A Part #	40513A Part #
1	Charger Case	41129A	41128A
2	Transformer	48413A	48409A
3	Electronic Controller Kit	47500A	48200A
4	Capacitor, 660V.A.C.	912132	912132
5	Heat Sink Assembly	912212	912212
6	Ammeter	40200A	40200A
7	Fuse Holder	912382	912382
8	Strain Relief, A.C. Cord	837525	837525
9	Strain Relief, D.C. Cord	747553	747553
10	D.C. Cord Assembly	51986A	51986A
11	A.C. Cord Assembly	51974A	908947
12	Housing	911470	911470
13	D.C. Plug Lock Key	795020	795020

Clarke Technology Vision 21i - Vision V
 Vacuum Motor Model
 Drawing 8/94
 Form # 44917A

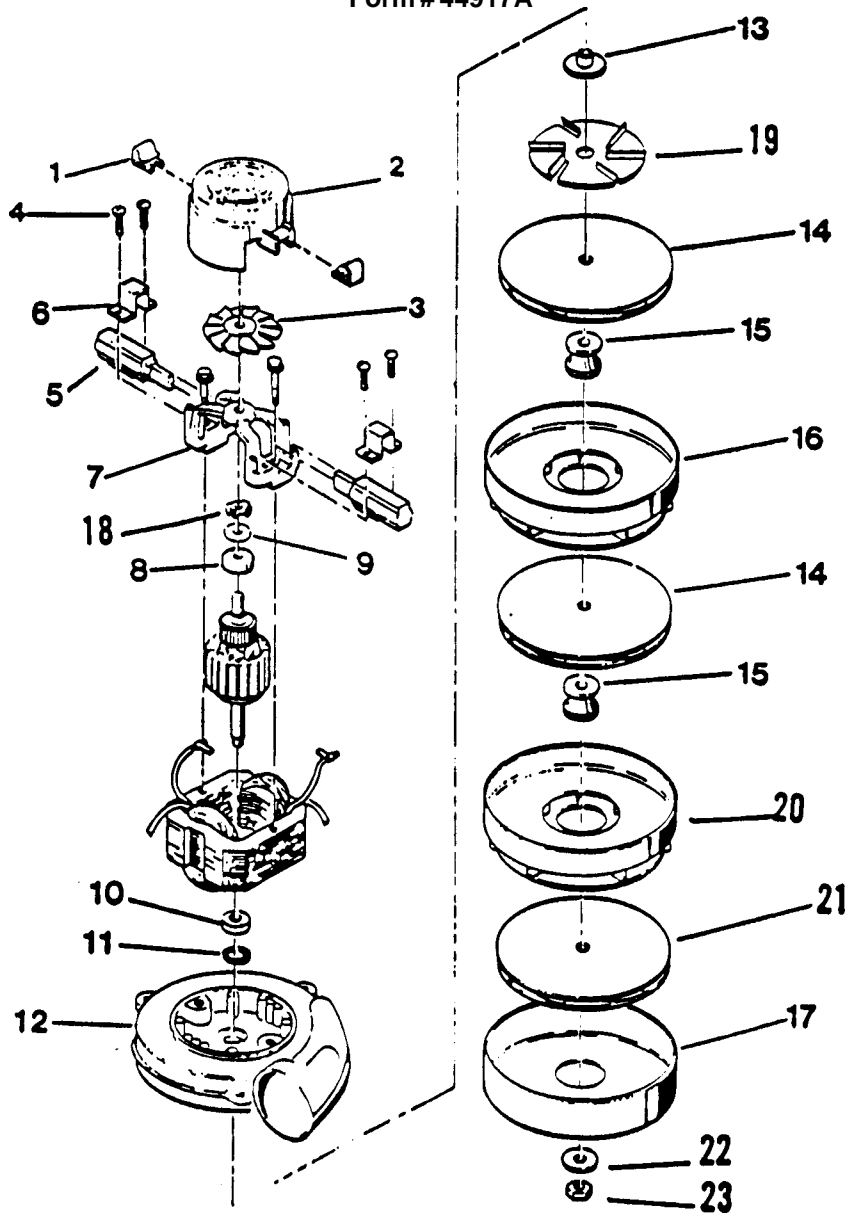

Ref #	Part No.	Description	Qty
1	51913A	Clip (optional)	2
2	54809A	Housing Vent	1
* 3		Fan	1
4	85303A	Screw - 8x32 - 3/8 P.N.	4
5	40817A	Brush, Mechanism	2
6	51914A	Clamp	2
7	50618A	Bracket, Commutator E.	1
* 8		Bearing	1
9	672714	Disc	1
* 10		Bearing	1
11	59803A	Washer, Neoprene	1
* 12		Bracket, Fan End	1
13	58500A	Spacer	1

Ref #	Part No.	Description	Qty
14	53914A	Fan, Rotating	2
15	658201	Spacer	2
* 16		Fan, Stationary	1
* 17		Shell, Fan	1
18	638313	Spring, Load	1
* 19		Fan, Air Seal	1
* 20		Fan, Stationary	1
* 21		Fan, Rotating	1
* 22		Washer	1
* 23		Nut	1

***NOTE:** #'s 3, 8, 10, 12, 16, 17, 19, 20, 21, 22, & 23 are not available at this time.

CLARKE TECHNOLOGY Vision 21i - Vision V Electrical Schematic 7/99

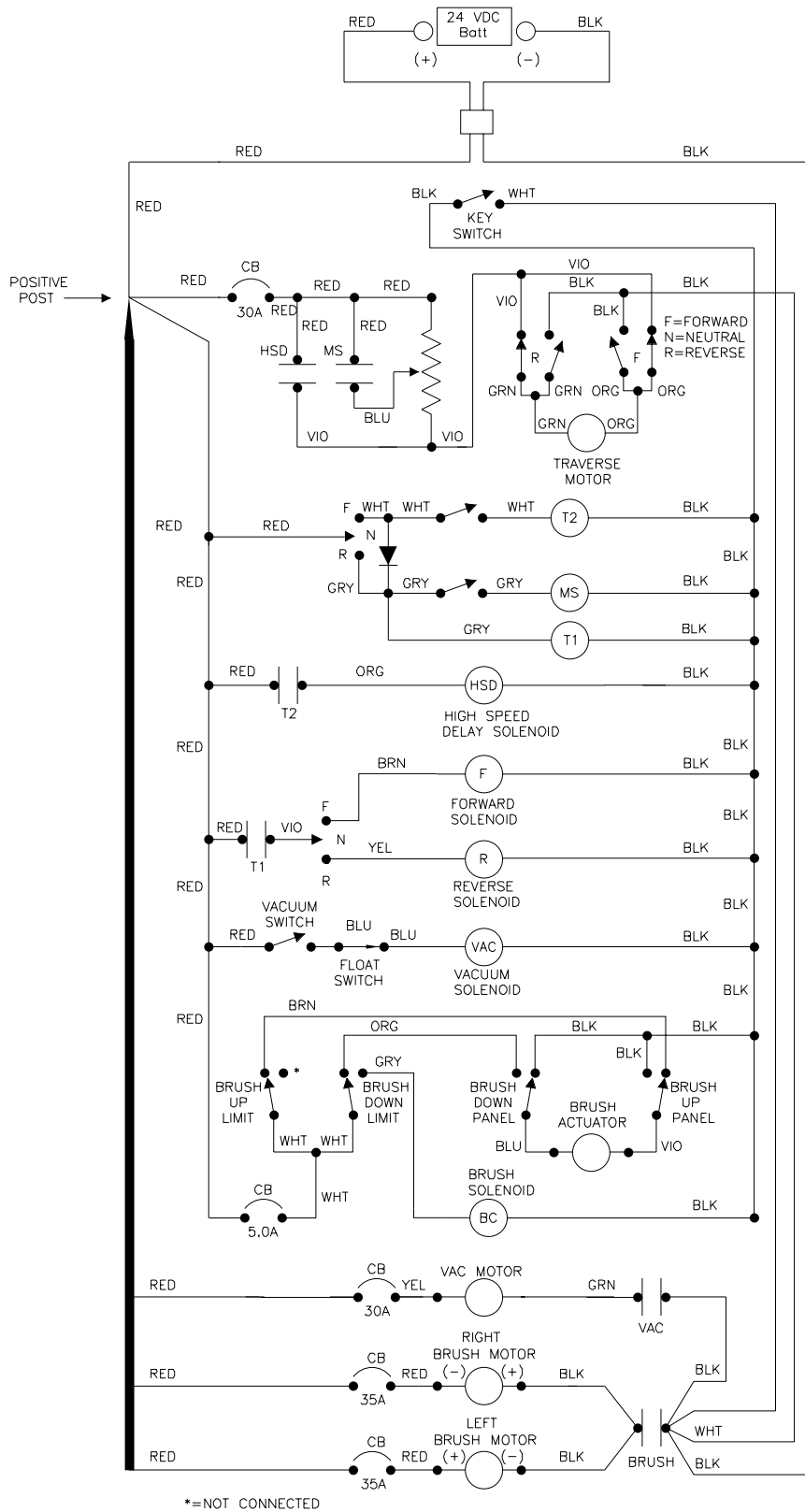

**CLARKE TECHNOLOGY Vision 21i and Vision V
 Connection Diagram 1/97
 Front of Machine (Tank Removed)**

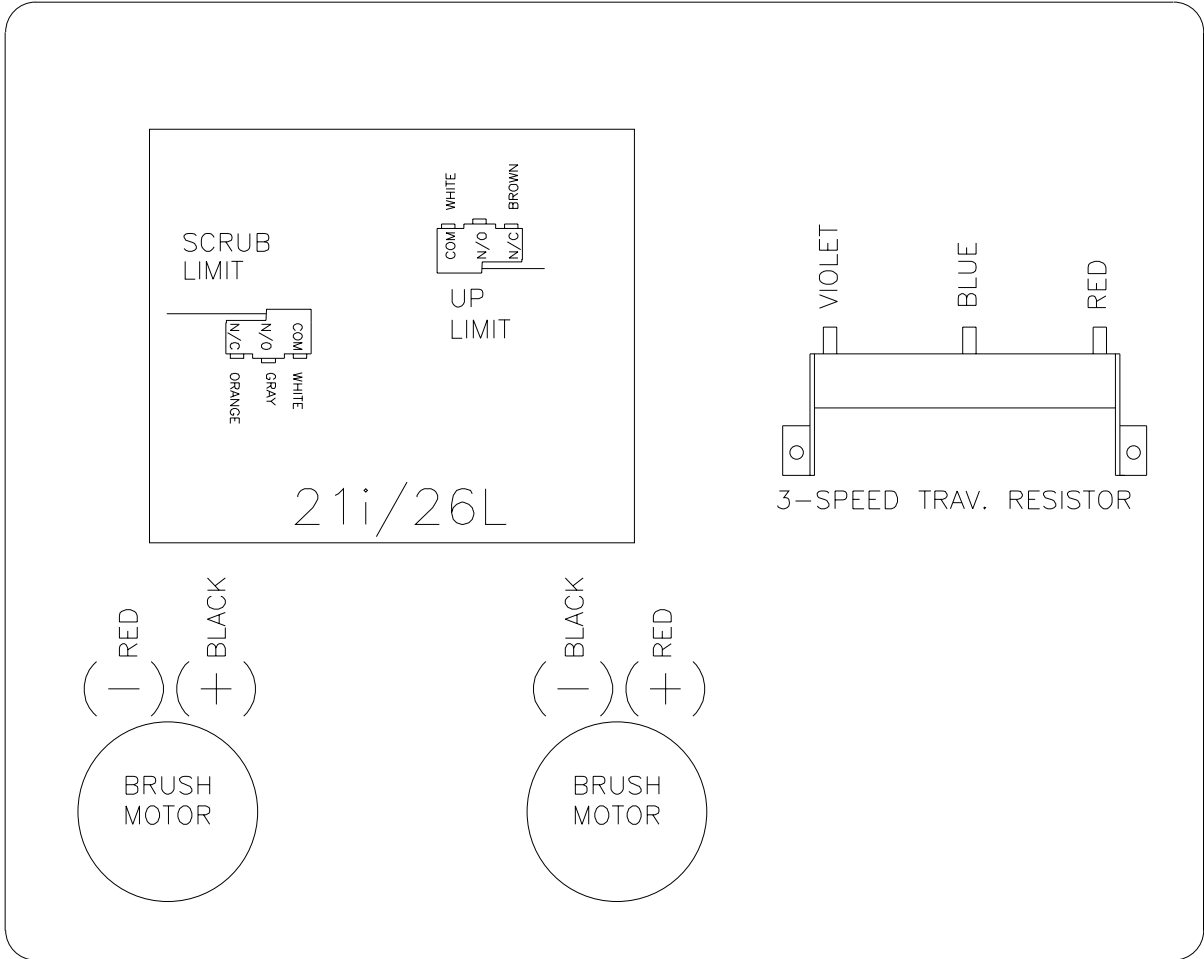

**CLARKE TECHNOLOGY Vision 21i and Vision V
 Connection Diagram 1/97
 Rear of Machine (Rear cover open)**

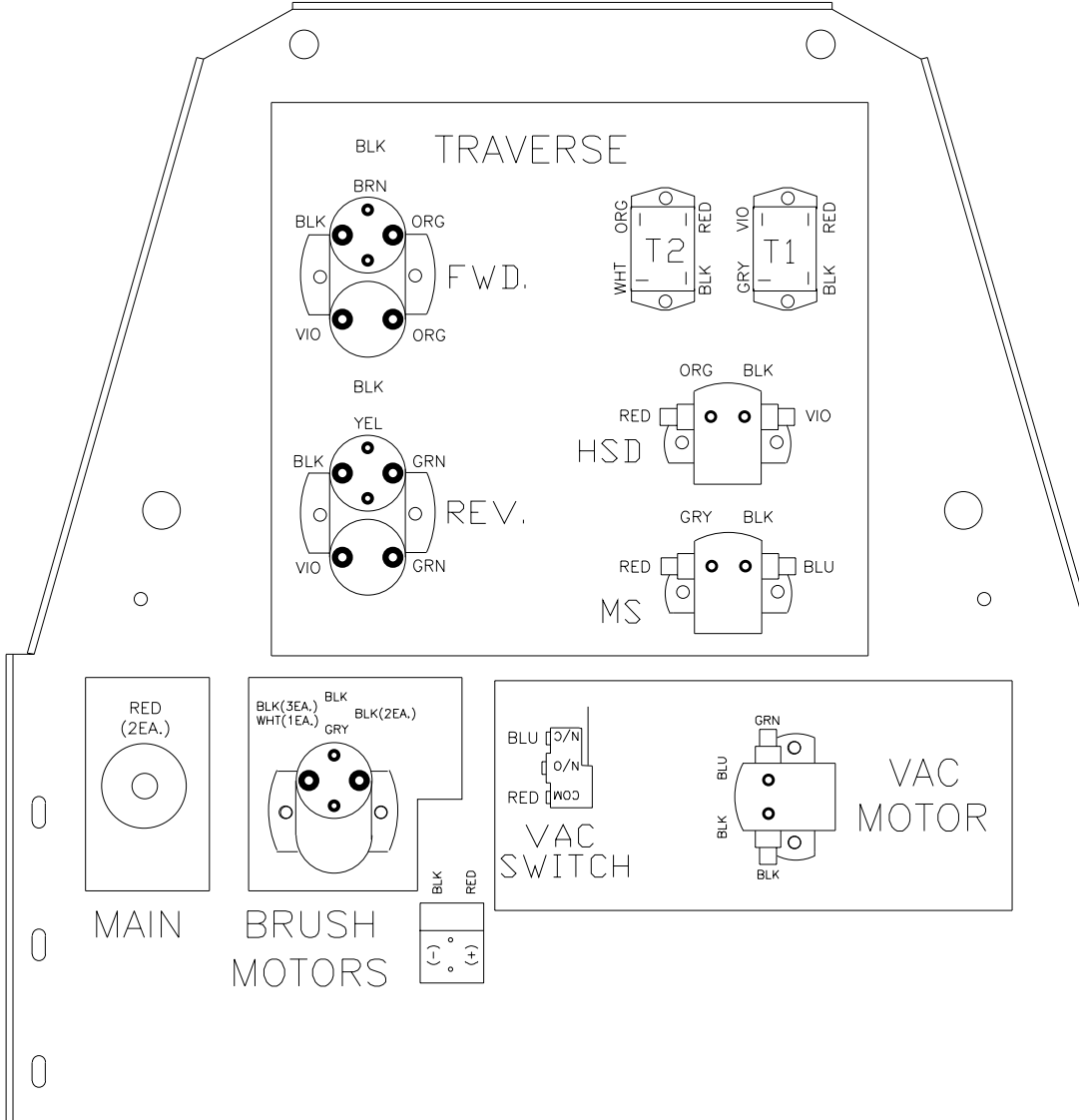

**CLARKE TECHNOLOGY Vision 21i and Vision V
Connection Diagram 1/97
Inside Rear Cover**

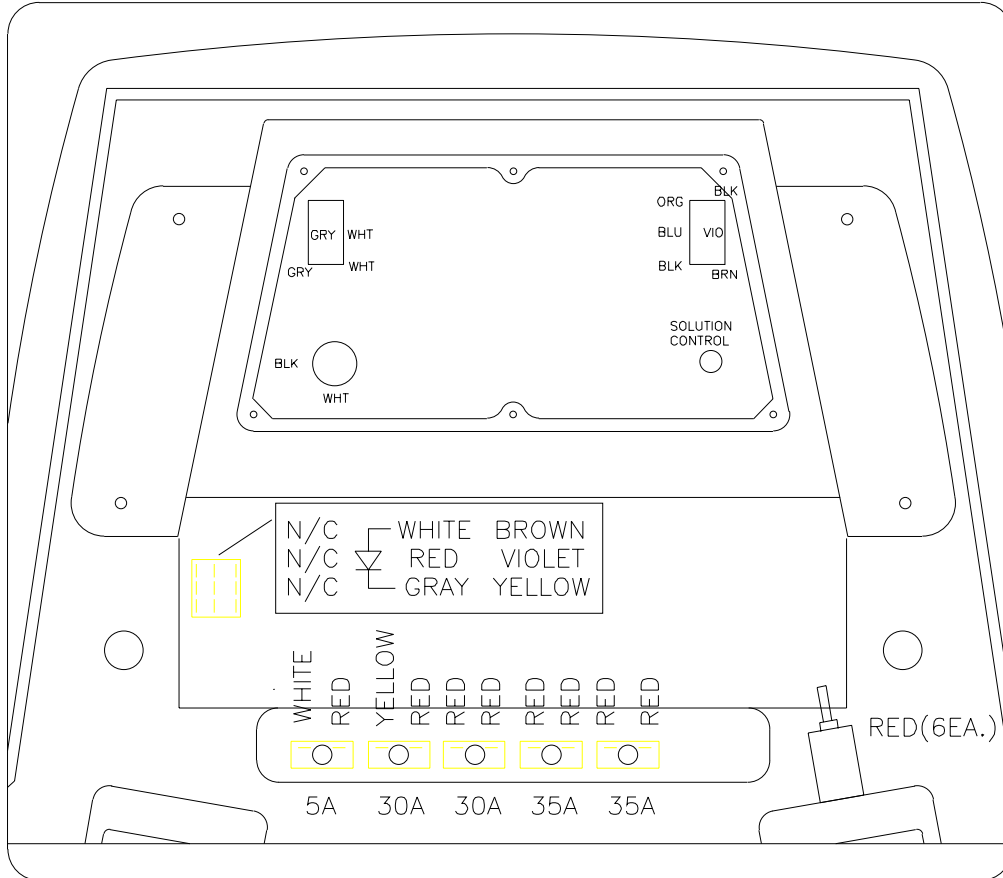

ALTO® PRODUCT SUPPORT BRANCHES

U. S. A. Locations

HEAD OFFICE

ALTO U.S. Inc., St. Louis, Missouri
390 S. Woods Mill Rd., Suite 300
Chesterfield, Missouri 63017-3433

PRODUCTION FACILITIES

ALTO U.S. Inc., Springdale, Arkansas
2100 Highway 265
Springdale, Arkansas 72764
(501) 750-1000
Customer Service - 1-800-253-0367
Technical Service - 1-800-356-7274

ALTO U.S. Inc., Bowling Green, Ohio 43402
1100 Haskins

ALTO U.S. Inc., Clearwater, Florida 33765
1500 N. Belcher Road

SERVICE FACILITIES

ALTO U.S. Inc., Carlstadt, New Jersey 07072
150 Commerce Road
(201) 460-4774

ALTO U.S. Inc., Elk Grove, Illinois 60007
2280 Elmhurst Road
(847) 956-7900

ALTO U.S. Inc., Denver, Colorado 80204
1955 West 13th Ave.
(303) 623 4367

ALTO U.S. Inc., Houston, Texas 77040
7215 North Gessner Road

SALES AND SERVICE FACILITIES

ALTO U.S. Inc., Madison Heights, Michigan 48071-0158
29815 John R.
(810) 544-6300

ALTO U.S. Inc., Marietta, Georgia 30062
1355 West Oak Common Lane
(770) 973-5225

CLARKE TECHNOLOGY
AMERICAN SANDERS TECHNOLOGY
A.L. COOK TECHNOLOGY
Customer Service Headquarters and Factory
2100 Highway 265
Springdale, Arkansas 72764
(501) 750-1000
Technical Service
1-800-356-7274

European Locations

PRODUCTION FACILITIES

ALTO Danmark A/S, Aalborg
Blytaekervej 2
DK-9000 Aalborg
+45 72 18 21 00

ALTO Danmark A/S, Hadsund
Industrikvarteret
DK-9560 Hadsund
+45 72 18 21 00

SALES SUBSIDIARIES

ALTO Canada Ltd., Rexdale Ontario
24 Constellation Ct.
(416) 675-5830

ALTO Overseas Inc., Sydney (Australia)
1B/8 Resolution Drive
Caringbah NSW 2229
+61 2 9524 6122

ALTO Cleaning Systems Asia Pte Ltd., Singapore
271 Bukit Timah Rd.
#04-11 Balmoral Plaza
Singapore 259708
+65 8366 455

ALTO Deutschland GmbH, Fronenberg (Germany)
Ardeyer Str. 15
D-58730 Fronenberg
+49 2373 754 200

ALTO Cleaning Systems (UK) Ltd., Penrith
Gilwilly Industrial Estate
Penrith
Cumbria CA11 9BN
+44 1768 868 995

ALTO France S.A. Strasbourg
B.P. 44, 4 Place d'Ostwald
F-67036 Strasbourg
Cedex 2
+33 3 8828 8400

ALTO Nederland B.V. Vianen
Stuartweg 4C
NL-4131 NJ Vianen
+31 347 324000

ALTO Sverige AB, Molndal (Sweden)
Aminogatan 18
Box 4029
S-431 04 Molndal
+46 31 706 73 00

ALTO Norge A/S, Oslo (Norway)
Bjornerudveien 24
N-1266
+47 2275 1770

CLARKE TECHNOLOGY U.S. WARRANTY

This ALTO Industrial/Commercial Product is warranted to be free from defects in materials and workmanship under normal use and service for a period of one year from the date of purchase, when operated and maintained in accordance with Clarke Technology's Maintenance and Operations Instructions.

The brush drive and traverse motors are warranted to be free from defects in materials and workmanship under normal use and service for one additional year, for a total of two years, from the date of purchase, provided the motors are inspected for carbon motor brush wear at six-month intervals by an authorized Clarke Technology repair station. Failure to comply with the six-month inspection requirement or failure to replace worn motor brushes identified during the inspection will void the additional one-year warranty on the motors. Cost of the six-month inspection and replacement of carbon motor brushes is the responsibility of the purchaser. In the event of a warranty claim on the motors, proof of inspection and any required motor brush replacement must be provided.

This warranty is extended only to the original purchaser for use of the product. It does not cover normal wear parts such as electrical cable, rubber parts, hoses and motor brushes.

Clarke Technology's liability under this warranty is limited to repair of the product and/or replacement of parts and is given to purchaser in lieu of all other remedies, including INCIDENTAL AND CONSEQUENTIAL DAMAGES.

THERE ARE NO EXPRESS WARRANTIES OTHER THAN THOSE SPECIFIED HEREIN. THERE ARE NO WARRANTIES WHICH EXTEND BEYOND THE DESCRIPTION OF THE FACE HEREOF. NO WARRANTIES, INCLUDING BUT NOT LIMITED TO WARRANTY OF MERCHANTABILITY, SHALL BE IMPLIED. A warranty registration card is provided with your Clarke Technology product. Return the card to assist Clarke Technology in providing the performance you expect from your new floor machine.

If difficulty develops with the product, you should:

- (a). Contact the nearest authorized Clarke Technology repair location or contact the Clarke Technology Service Operations Department, 2100 Highway 265, Springdale, Arkansas 72764, for the nearest authorized Clarke Technology repair location. Only these locations are authorized to make repairs to the product under this warranty.
- (b). Return the product to the nearest Clarke Technology repair location. Transportation charges to and from the repair location must be prepaid by the purchaser.
- (c). Clarke Technology will repair the product and or replace any defective parts without charge within a reasonable time after receipt of the product.

ALTO U.S. Inc., 2100 Highway 265, Springdale, Arkansas 72764.

BATTERY WARRANTY

In addition to the terms above (except as to the one-year period), any original equipment Clarke Technology Battery which becomes unserviceable under normal use within a period of ninety (90) days from date of sale to the original user will be repaired or replaced with one of equal specification at our option, F.O.B. any authorized Clarke Technology Sales or Service Branch, with no charge to the user, except transportation costs. After expiration of the above ninety (90) day period, any battery which fails under normal use will be adjusted to the original user with a new battery of equal specification on an eighteen (18) months pro rate basis from the date of purchase. Adjustment will be determined using the current list price, plus transportation costs. Warranty is rendered null and void if battery is not kept filled to the proper level with DISTILLED WATER.

CLARKE TECHNOLOGY POLYDUR AUTOMATIC SCRUBBER SOLUTION AND RECOVERY TANK U.S. EIGHT YEAR GUARANTEE

Your new Clarke Technology Vision Automatic Scrubber has Polydur solution and recovery tanks. Polydur is a rotationally molded, medium-density linear polyethylene that won't crack or dent, and withstands most corrosives and temperature extremes. Clarke Technology backs up your Polydur Tank with its eight year guarantee. If a tank breaks or leaks under normal use within eight years of the date of purchase, it will be replaced free.

CLARKE TECHNOLOGY UNIBODY FRAME U.S. FIVE YEAR WARRANTY

Clarke Technology warrants the frame for the new Vision Automatic Scrubber for a period of five years against defects in materials and workmanship under normal use and service.

CLARKE TECHNOLOGY reserves the right to make changes or improvements to its machine without notice.

Always use genuine Clarke Technology Parts for repair.



**CLARKE TECHNOLOGY
2100 Highway 265
Springdale, Arkansas, 72764**