



Electronic Service Manuals

This electronic document is provided as a service to our customers. We do not create the contents of the information contained in this document. Should you have detailed questions pertaining to the information contained in this document, you may contact Michco, or the manufacturer which provided the original information in this electronic deliverable. Michco's only part in this electronic deliverable was the electronic assembly process. By providing this manual on line we are not guaranteeing parts availability.

You may contact Michco through the following methods:

Phone (517) 484-9312 or (800) 331-3339

2011 N. High St. -- Lansing, Michigan -- 48906

Fax: (517) 484-9836

Email: CustServe@Michco.com

Web site: www.Michco.Com

Parts Web site: www.FloorMachineParts.Com

Order Parts on Line at:

www.FloorMachineParts.Com

Directly to Parts & Service:

By Email: **Shop@Michco.com**

By Fax: (517) 702-2041

By Voice: Use numbers above.

Serving the Cleaning Industry Since 1922

Notice: All copyrighted material remains property of original owners, all trademarks are property of respective owners. Manuals are subject to Manufacturer's reproduction limitations. Originals or reproductions were provided by manufacturers through a request. We make no warranty as to the correctness of information provided in this document and you assume all risk. By placing these manuals on line we are not declaring our corporation to be an manufacturer authorized dealer or provider, please check our web site for authorized manufacturers we represent.



Operator's Manual

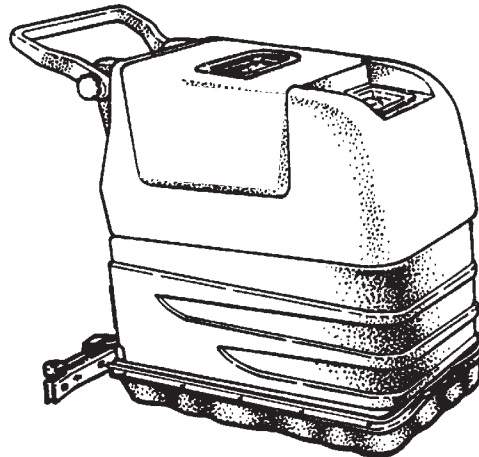

Vision 17B/BT

READ THIS BOOK

This book has important information for the use and safe operation of this machine. Failure to read this book prior to operating or attempting any service or maintenance procedure to your ALTO machine could result in injury to you or to other personnel; damage to the machine or to other property could occur as well. You must have training in the operation of this machine before using it. If your operator(s) cannot read English, have this manual explained fully before attempting to operate this machine.

Si Ud. o sus operadores no pueden leer el Inglés, se hagan explicar este manual completamente antes de tratar el manejo o servicio de esta máquina.

All directions given in this book are as seen from the operator's position at the rear of the machine.

For new books write to: ALTO U.S. Inc., 2100 Highway 265, Springdale, Arkansas 72764.

Table of Contents

Operator Safety Instructions	3
Introduction & Machine Specifications	5
Procedures for Transporting Machine	6
Machine Controls & Features	7
How to Prepare the Machine for Operation	10
How to Install the Squeegee	10
How to Install the Squeegee Connection	11
How to Install or Remove a Brush or Pad Driver	11
How to Install the Batteries	12
How to Operate the Machine	13
Filling the Solution Tank	13
Operating the Machine	13
Shutting Down the Machine	14
How to Clean a Very Dirty Floor	14
Maintenance	15
Procedures Before Work is Began	16
Procedures to Perform at the End of Work	16
Weekly Maintenance	18
Battery Maintenance	18
How to Charge the Batteries	19
Machine Variables	20
Accessories	21

Section II - Parts and Service Manual

How to Correct Problems in the Machine	24
Vision 17B Machine Assembly Drawing	26
Parts List	27
Vision 17BT Machine Assembly Drawing	28
Parts List	29
Vision 17B Axle Assembly Drawing and Parts List	30
Vision 17BT Axle Assembly Drawing and Parts List	31
Vision 17B/BT Brush Lift Assembly Drawing and Parts List	32
Vision 17B Main Frame Assembly Drawing and Parts List	33
Vision 17B/BT Brush Motor Assembly Drawing and Parts List	34
Vision 17B Control Panel Assembly Drawing and Parts List	35
Vision 17BT Control Panel Assembly Drawing and Parts List	36
Vision 17 Squeegee Assembly Drawing and Parts List	37
Vision 17 Solution Tank Assembly Drawing and Parts List	38
Vision 17 Recovery Tank Assembly Drawing and Parts List	39
Vision 17B Support Assembly Drawing and Parts List	40
Vision 17BT Support Assembly Drawing and Parts List	41
Vision 17BT Brake Kit Assembly Drawing and Parts List	42
Vision 17B/BT Vacuum Motor Drawing and Parts List	43
Vision 17 Brush Gear Box Drawing and Parts List	44
Vision 17 Brush Motor Drawing and Parts List	45
Vision 17BT Traverse Motor Drawing and Parts List	46
Vision 17BT Traverse Motor Drawing and Parts List	47
Vision 17B/BT Battery Charger Drawing and Parts List	48
Vision 17B Electrical Schematic	49
Vision 17BT Electrical Schematic	50
Vision 17B Connection Diagram	51
Vision 17BT Connection Diagram	52

OPERATOR SAFETY INSTRUCTIONS



WARNING



AVERTISSEMENT



ADVERTENCIA



DANGER:

Failure to read and observe all **DANGER** statements could result in severe bodily injury or death. Read and observe all **DANGER** statements found in your Owner's Manual and on your machine.



WARNING:

Failure to read and observe all **WARNING** statements could result in injury to you or to other personnel; property damage could occur as well. Read and observe all **WARNING** statements found in your Owner's Manual and on your machine.



CAUTION:

Failure to read and observe all **CAUTION** statements could result in damage to the machine or to other property. Read and observe all **CAUTION** statements found in our Owner's Manual and on your machine.



DANGER:

Failure to read the Owner's Manual prior to operating or attempting any service or maintenance procedure to your Clarke Technology machine could result in injury to you or to other personnel; damage to the machine or to other property could occur as well. You must have training in the operation of this machine before using it. If your operator(s) cannot read English, have this manual explained fully before attempting to operate this machine.



DANGER:

Operating a machine that is not completely or fully assembled could result in injury or property damage. Do not operate this machine until it is completely assembled. Inspect the machine carefully before operation.



DANGER:

Machines can cause an explosion when operated near flammable materials and vapors. Do not use this machine with or near fuels, grain dust, solvents, thinners, or other flammable materials. This machine is not suitable for picking up hazardous dust.



DANGER:

Lead acid batteries generate gases which can cause an explosion. Keep sparks and flames away from batteries. Do not smoke around this machine. Charge the batteries only in an area with good ventilation. Make sure that the AC charger plug is unplugged from the wall receptacle before connecting or disconnecting the DC plug to or from the battery pack.



DANGER:

Waste Disposal Method: Dispose as hazardous waste. Observe all federal, state and local environmental regulations for acid or lead scrap. Send batteries to a battery recycling center for reclamation following applicable federal, state and local regulations.



DANGER:

Working with batteries can be dangerous! Always wear eye protection and protective clothing when working near batteries. Remove all jewelry. Do not put tools or other metal objects across the battery terminals, or the tops of the batteries.



DANGER:

Using a charger with a damaged power cord could result in an electrocution. Do not use the charger if the power cord is damaged.













WARNING:

Operating this machine from anywhere other than from the back of the machine could result in injury or damage. Operate this machine only from the rear.



WARNING:

This machine is heavy. Get assistance before attempting to transport or move it. Use two able persons to move the machine on a ramp or incline. Always move slowly. Do not turn the machine on a ramp. If operating a machine on a gradient over 2%, do not stop, turn, or park. Read the "Procedures For Transporting" in this manual before transporting.

-  **WARNING:** Machines can topple over if guided over the edges of stairs or loading docks and cause injury or damage. Stop and leave this machine only on a level surface. When you stop the machine, put all switches into their "OFF" position.
-  **WARNING:** Maintenance and repairs performed by unauthorized personnel could result in damage or injury. Maintenance and repairs must be performed by authorized Clarke Technology personnel only.
-  **WARNING:** Any alternations or modifications of this machine could result in damage to the machine or injury to the operator or other bystanders. Alterations or modifications not authorized by the manufacturer voids any and all warranties and liabilities.
-  **WARNING:** Electrical components of this machine can "short-out" if exposed to water or moisture. Keep the electrical components of the machine dry. Wipe the machine down after each use. For storage, keep the machine in a dry building.
-  **WARNING:** Operating a machine without observing all labels and instructional information could result in injury or damage. Read all machine labels before attempting to operate. Make sure all of the labels and instructional information are attached or fastened to the machine. Get replacement labels and decals from your Clarke Technology distributor.
-  **WARNING:** Wet floor surfaces can be slippery. Water solutions or cleaning materials used with this type of machine can leave wet areas on the floor surface. These areas can cause a dangerous condition for the operator or other persons. Always put "Caution" signs around/near the area you are cleaning.
-  **WARNING:** Improper discharge of waste water may damage the environment and be illegal. The United States Environmental Protection Agency has established certain regulations regarding discharge of waste water. Also, city and state regulations regarding this discharge may be in effect in your area. Understand and follow the regulations in your area. Be aware of the environmental hazards of chemicals that you dispose.
-  **CAUTION:** When cleaning, servicing or maintaining the machine, replacing parts or converting to another function, the power source should be switched off. Mains operated machines should be disconnected by removing the power plug. Battery operated machines should be disconnected by removing the key of the power switch, or any other effective means.
-  **CAUTION:** Use of this machine to move other objects or to climb on could result in injury or damage. Do not use this machine as a step or furniture. Do not ride on this machine.
-  **CAUTION:** Your machine warranty will be voided if anything other than genuine Clarke Technology parts are used on your machine. Always use Clarke Technology parts for replacement.

Introduction & Machine Specifications

The newly designed Vision 17 automatic scrubber increases labor efficiency while providing superior cleaning. This unit dispenses the solution, scrubs the floor and then recovers the soiled solution - ***all in one pass.***

The Vision 17 is available in four models. The four models are battery versions, one a standard battery and the other a battery version with traverse and each with parking brake as standard. The battery version comes complete with two 12V batteries, one battery cable assembly, one battery cable, one battery charger, a scrub brush or pad driver and one Operator's Manual.

The Vision 17B/BT can be adapted to clean any hard floor surface with a variety of floor cleaning accessories including a variety of bassine, steel, polypropylene, and nylon scrub brushes, pads and pad drivers. See the list of optional accessories on page 21 of this manual.

Model Code Number	Vision 17B 00380A 24 Volt	Vision 17B w/Brake 00380E 24 Volt	Vision 17BT 00390A 24V w/Traverse	Vision 17BT w/Brake 00390E 24V w/Traverse
Power Source	2-12V Batteries			
Sound Level (dba)	69			
Charging Unit	10A Charger			
Brush Drive Motor	3/4 hp / .56 kW			
Brush Speed	200 rpm			
Vacuum Motor	3/4 hp, 3 stage / .56 kW, 3 stage			
Solution Tank	8 gallon / 30.28 L			
Recovery Tank	9 gallon / 34.07 L			
Speed Forward	brush assist	brush assist	3 speed	3 speed
Vibration	< 2.5m/s ²			
Squeege	24" self-adjusting swing / 60.96 cm self-adjusting swing			
Scrubbing Path	17" width / 43.18 cm. width			
Dimensions	36" x 19" x 33" / 91.44 cm x 48.26 cm x 83.82 cm			
Machine Weight	263 lbs. w/Battery / 119.3 kg w/Battery		278 lbs. w/Battery / 126.1 kg w/battery	
Warranty	1 year			

Note: Additional machine variables are available. See accessories page for codes and description.

PROCEDURES FOR TRANSPORTING

How to Put the Machine Into a Van or Truck

 **WARNING:** This machine is heavy. Get assistance before attempting to transport or move. Use two able persons to move the machine on a ramp or incline. Always move slowly. Do not turn the machine on a ramp. Do not stop and leave the machine on a ramp or incline.

To load the machine into a van or truck follow this procedure:

1. Remove the squeegee and the brush (see "How to Prepare Machine for Operation").
2. Obtain a loading ramp that is at least 8' long and secure enough to support the weight of the machine.
3. Make sure the ramp is clean and dry.
4. Put the ramp into position and secure.
5. Align the machine on a level surface in front of the ramp.
6. With the assistance of another person, guide the machine up the ramp slowly.
7. Securely fasten the machine to the vehicle.

How to Remove a Machine From a Van or Truck

To remove the machine from a van or truck, follow this procedure:

1. Make sure that there are no obstructions in the area.
2. Obtain an unloading ramp that is at least 8' long and strong enough to support the weight of the machine.
3. Make sure the ramp is clean and dry.
4. Put the ramp into position and secure.
5. Untie the machine.
6. With the aid of another person, carefully guide the machine out of the truck or van onto the unloading ramp slowly. Never stand below machine or ramp.
7. When guiding the machine on the unloading ramp, position yourself to maintain a slow speed.

MACHINE CONTROLS and FEATURES

Brush Switch. See Figure 1.

The brush switch is to the left of the vacuum switch on the control panel. To start the brush motor, press the top of the switch. To stop the brush motor, press the bottom of the switch.

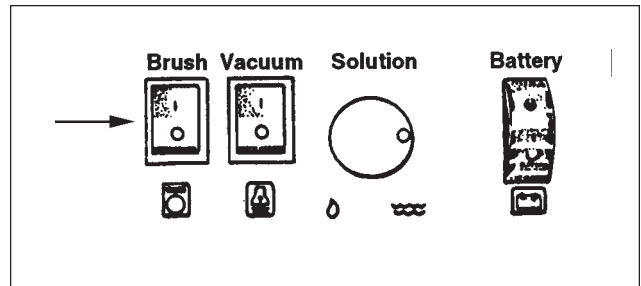

Figure 1

Vacuum Switch. See Figure 2.

The vacuum switch is to the left of the solution control knob. To start the vacuum motor, press the top of the switch. To stop the vacuum motor, press the bottom of the switch.

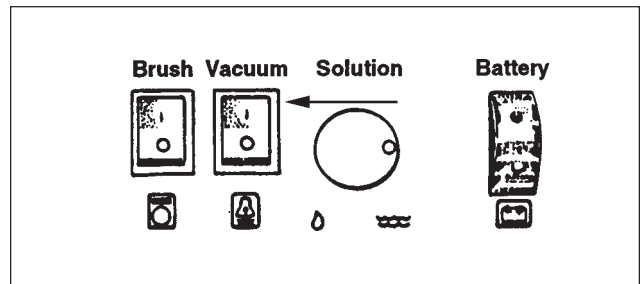

Figure 2

Solution Control Knob. See Figure 3.

The solution control knob is in the middle of the control panel. For more solution, turn the knob to the right. For less solution, turn the knob to the left.

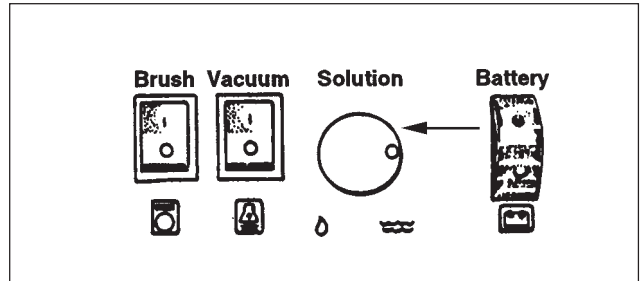

Figure 3

Circuit Breakers. See Figure 4.

There are two circuit breakers. One to protect the vacuum motor and one to protect the brush drive motor. The circuit breakers are located on the lower left side of the tank support. Push the circuit breakers to reset the vacuum drive motor or the brush drive motor. For the traverse model there is one additional circuit breaker for the traverse motor.

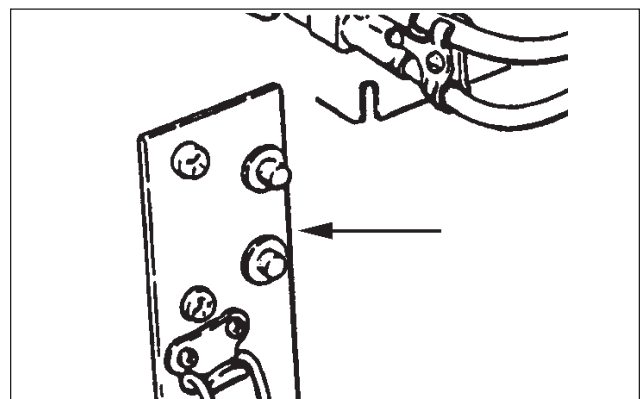

Figure 4

MACHINE CONTROLS and FEATURES (cont'd)

Voltmeter. See Figure 5.

This gauge indicates the amount of power in the batteries. If the reading is in the lower area of the meter, the battery voltage is low. See the section of this book called "Maintenance".

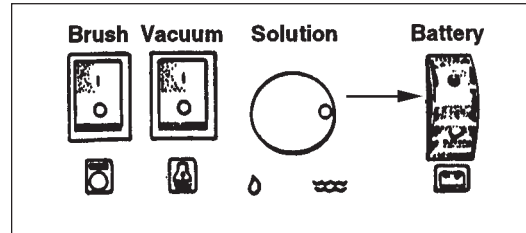

Figure 5

Brush Control Pedal. See Figure 6.

The brush control pedal is at the back of the machine in the lower right corner. Use your foot to operate the pedal. To lower the brush, push the pedal down and to the left, releasing it from the locked position. To raise the brush, push the pedal down and to the right engaging the lock.

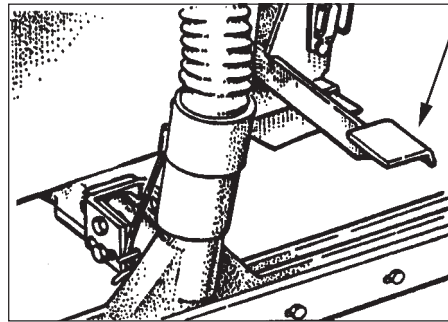

Figure 6

Brush Tilt Control.

The brush tilt control is on the left side by the motor. To access the motor, turn off the key and remove the squeegee cable, and undo the tank clamps. To adjust how the machine pulls, loosen the screw. Tilt the motor forward to decrease the brush-assist traverse. Tilt the motor back to increase the brush-assist traverse. After adjustment retighten the screw.

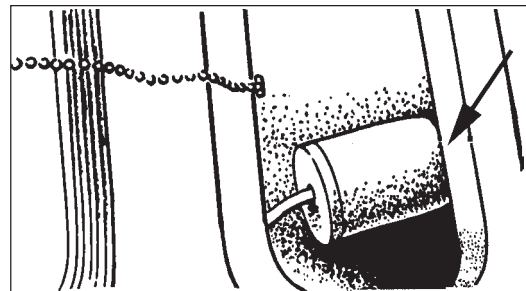

Figure 7

The Float Shut-Off. See Figure 7.

The float shut-off is in the back of the recovery tank. When the liquid raises the float, the float switch will automatically turn the vacuum motor off. To continue working you must drain the recovery tank.

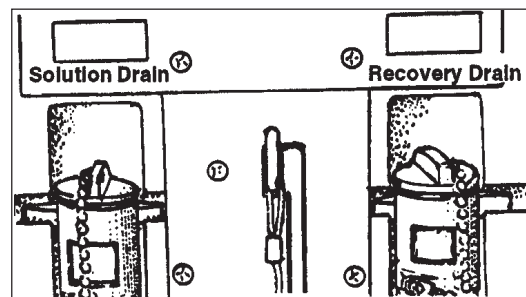

Figure 8

The Squeegee Handle. See Figure 8.

The squeegee handle is at the back of the machine in the middle. To lower the squeegee, pull the handle to the right and lower. To raise the squeegee, lift the handle up and push to the left.

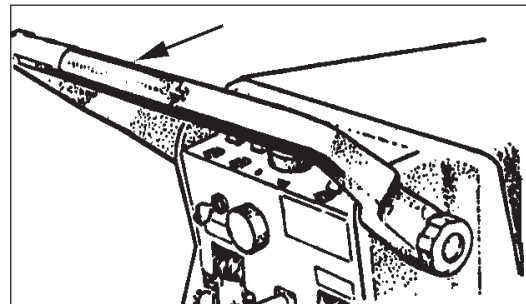

Figure 9

Traverse Switch. See Figure 9.

(For the Vision 17 battery model with traverse only)
The traverse switch is located on the handle. To activate the traverse, push the switch.

MACHINE CONTROLS and FEATURES (cont'd)

Traverse Speed Control. See Figure 10

The traverse speed is controlled by a variable speed knob. Turn the knob clockwise to increase speed.

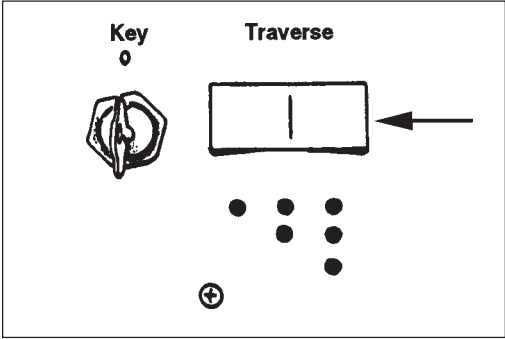

Figure 10

Brush Pressure Adjustment.

The brush pressure can be adjusted for normal cleaning or for stripping. Locate the knob on the rear of the brush motor. To access motor, turn off the key, remove the squeegee cable and undo tank clamps. Turn the knob clockwise to increase brush pressure (strip mode). Turn the knob counterclockwise to return to normal cleaning.

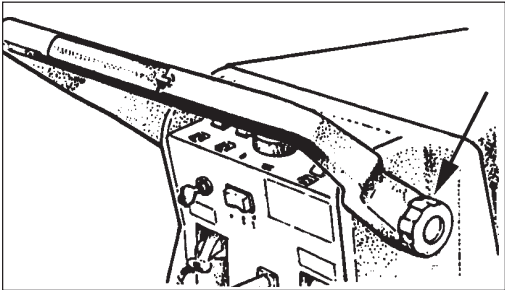

Figure 11

Machine Control Handle. See Figure 11

The machine control handle is located on the back side of the machine. The handle is adjustable for operator comfort and ease. The handle adjustment knobs are located at the base of the handle.

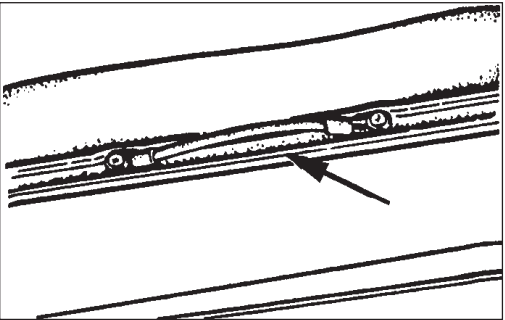

Figure 12

Machine Lift Handle. See Figure 12.

The machine lift handle is located on the front of the machine. Use this handle to lift the machine when changing the brush. See the section in this Owner's Manual "Installing or Removing a Brush or Pad Driver".

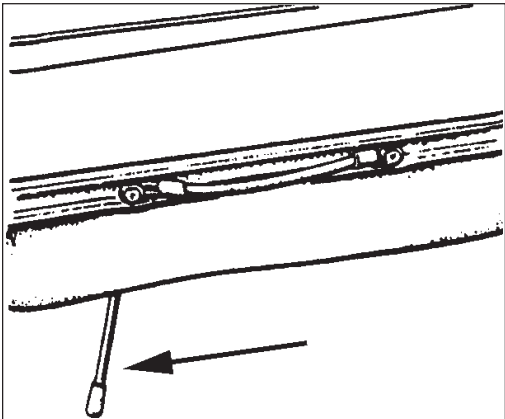

Figure 13

Machine Support Leg. See Figure 13.

The machine support leg is located in the front of the machine under the bumper skirt. Put the machine support leg down when installing or removing a brush or pad driver.

MACHINE CONTROLS and FEATURES (cont'd)

Key Switch. See Figure 14.

The battery traverse model has a key switch located on the back side of the control panel. The key switch must be turned to the on position (I) to activate the traverse. The key may be removed for security purposes from the off position (O).

The Parking Brake.

The brake prevents the movement of the machine. The brake pedal is at the back of the machine in the lower left corner. To activate the brake, push the pedal down. Lift the pedal to release the brake.

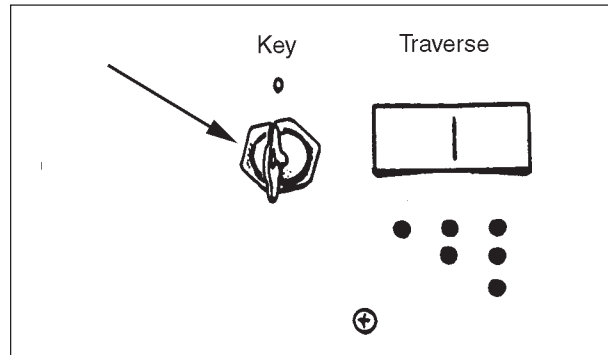

Figure 14

HOW TO PREPARE THE MACHINE FOR OPERATION

How to Install the Squeegee

To install the squeegee, follow this procedure:

1. Attach the squeegee cable to the squeegee lift arm (Figure 15) and squeegee bracket (Figure 16).
2. Raise the squeegee lift arm.
3. Place the squeegee onto the squeegee bracket.
4. Push the hair pin through the holes on the squeegee bracket.
5. Attach the squeegee hose to the hose connection on top of squeegee. See figure 17.

CAUTION: Leaving the squeegee "DOWN" when the machine is not in use can damage the squeegee blades. Always leave the squeegee in the "UP" position when not in use.

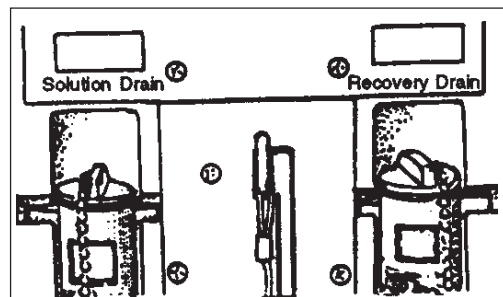

Figure 15

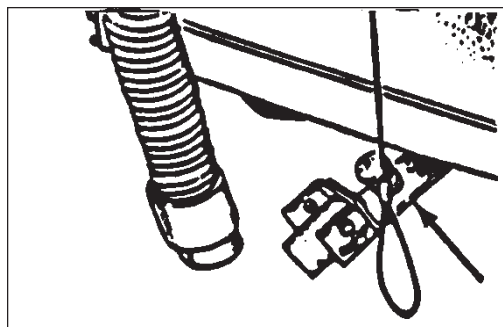

Figure 16

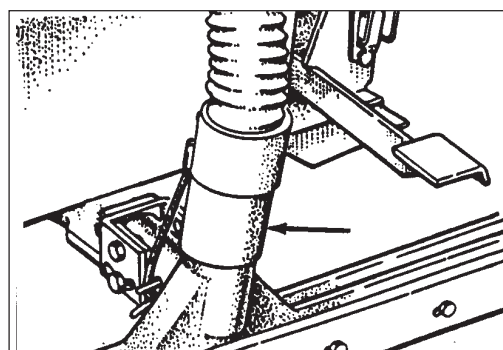

Figure 17

HOW TO PREPARE THE MACHINE FOR OPERATION

How to Install the Squeegee Connection

The proper method for assembling the squeegee connection is as follows::

1. Unscrew the nut completely.
2. Slide the nut and gasket onto the tube.
(Figure 1a)
3. Slide the elbow onto the tube and make sure the gasket is secured into the elbow.
(Figure 2a)
4. As you hold the elbow tight onto the tube, tighten the nut over the gasket and the elbow.
(Figure 3a)

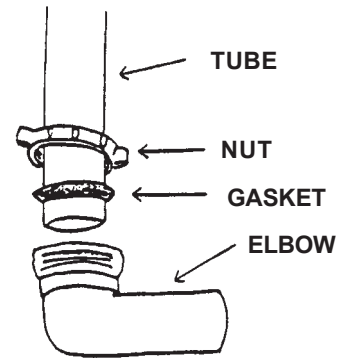

Figure 1a

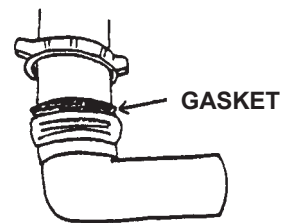

Figure 2a

How to Install or Remove a Brush or Pad Driver

To install or remove a brush or a pad driver, follow this procedure:

NOTE: The brush may spin off the machine if the brush switch is turned ON or OFF while the brush is in the raised position.

1. If machine is an electric model disconnect the power supply.
2. Put the squeegee down to the floor by pulling the squeegee handle to the right and down.
3. Remove the cotter pin from the squeegee bracket and remove the squeegee. See Figure 17.
4. Slide the squeegee bracket either right or left all the way under the machine skirt. See Figure 16.
5. While lifting the machine up with the machine lift handle (a), lower the support leg and position like a kickstand (b). See Figure 18
6. To install the brush or pad driver, align the lugs on the locking plate of the pad driver or brush with the adapter plate.
7. Turn the brush or pad driver clockwise to lock it in position.

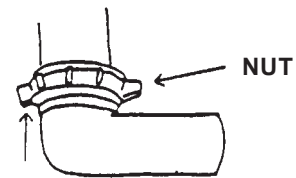

Figure 3a

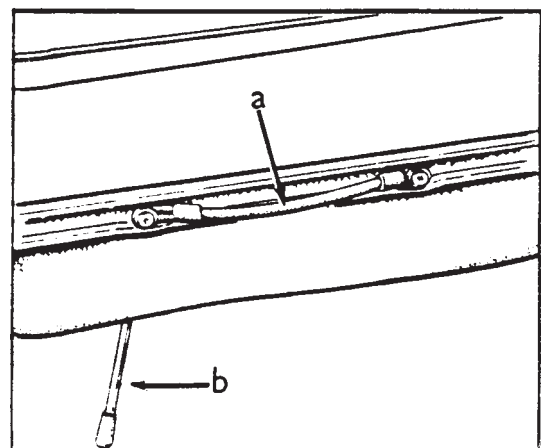

Figure 18

HOW TO PREPARE THE MACHINE FOR OPERATION (cont'd)

8. To remove a brush or pad driver, turn the pad driver or brush to the left and remove.
9. Lift up the machine with the lift handle and return the support leg to its normal position.

CAUTION: Leaving the brush motor switch in its "DOWN" position when the machine is not in use can damage the brush or pad driver. Always leave the brush motor in the "UP" position while not in use.

How to Install the Batteries

To install the batteries, follow this procedure:

NOTE: Batteries must be fully charged before operating. See section in this manual, "Charging the Batteries".

WARNING: Lifting batteries without help could result in an injury. Get help to lift the batteries. The batteries are heavy.

WARNING: Working with batteries can be dangerous. Always wear eye protection and protective clothing when working near batteries. **NO SMOKING.**

1. Empty both the recovery and solution tanks. (See - "End of Work Procedures").
2. Unlock the hold-down clamps located at the rear on either side of the machine. See figure 19.
3. Raise the battery compartment of the machine "up" by lifting up on the handle at the rear of the machine.
4. Install the batteries using the battery lift handles. See figure 20 for proper positioning of the batteries.
5. Close the battery compartment and re-lock the hold-down clamps.
6. Join the connector from the batteries to the connector attached to the tank support.

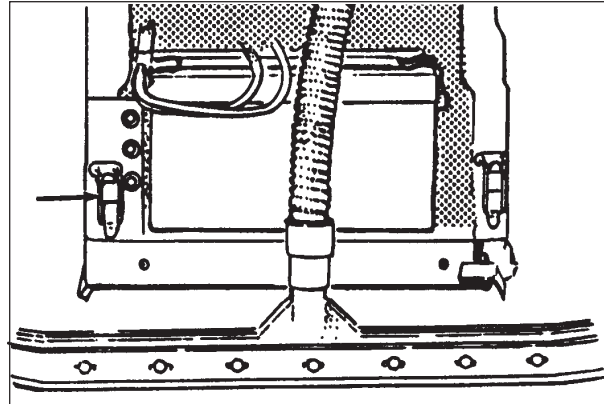

Figure 19

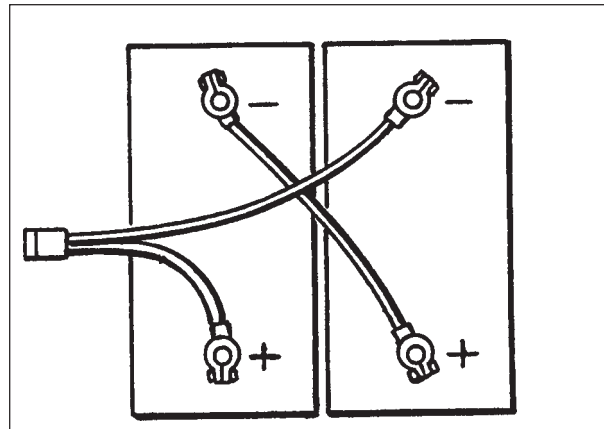

Figure 20

HOW TO OPERATE THE MACHINE

Filling the Solution Tank

To fill the solution tank, follow this procedure:

1. Lift the solution tank lid out of the opening. Allow the lid to hang to the front of the machine. See figure 21.
2. With a hose or bucket fill the solution tank with clean water to within one inch of the bottom of the opening.
3. Add a cleaning chemical to the water. For the correct amount, follow the manufacturer's directions shown on the chemical container.
4. Put the lid back onto the solution tank opening.



Figure 21

Operating the Machine

1. Put water and a cleaning chemical into the solution tank.
2. Lower the squeegee. To lower the squeegee, pull the squeegee handle to the right and lower.
3. Lower the brush. To lower the brush, step on the brush control lever (figure 22) and push down slightly, then move the lever to the left and allow it to come up.

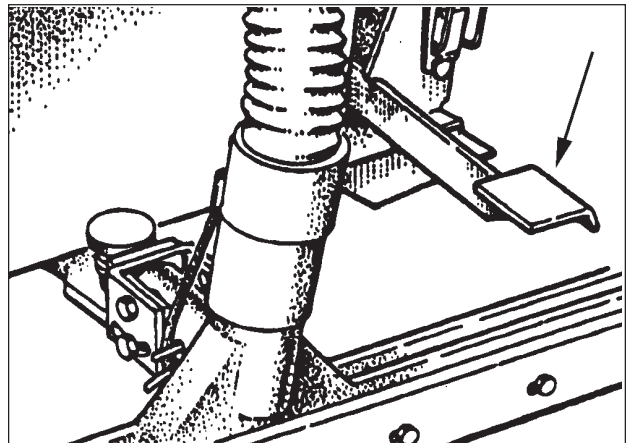

Figure 22

NOTE: Keep the machine moving when the brush is rotating on the floor.

4. Press the top of the brush switch to activate the brush motor.
5. Press vacuum switch to activate vacuum motor.
6. Activate the flow of solution by turning the solution control knob to the right. To make sure you have an even flow of solution, turn the knob to the right as the amount of solution in the tank decreases.
7. Move the machine forward in a straight and steady direction. If machine is a traverse model, select a speed and then press on the traverse handle switch to activate the traverse.

HOW TO OPERATE THE MACHINE (cont'd)

8. To turn the machine, push the rear of the machine to the side opposite the direction you want to turn. It is **NOT RECOMMENDED** that you move the machine backward during a cleaning operation.
9. When you make more passes across the floor, let the brush clean approximately 2 inches of the area already cleaned by the last pass.

NOTE: During most cleaning procedures, apply and remove the solution in one operation.

Shutting Down the Machine

To shut down the machine, follow this procedure:

1. Turn solution flow "Off" by turning the knob all the way to the left (counter clockwise).
2. Lift the squeegee up by lifting up on the handle and locking it into the "UP" position.
3. Press the bottom of the vacuum switch to turn the vacuum "Off".
4. Press the bottom of the brush switch to turn "off" the brush motor.
5. Raise the brush up by pushing down on the brush lift lever with your foot sliding the lever to the right.

NOTE: The brush may spin off the drive adapter if the brush switch is turned ON or OFF while the brush is in the raised position.

How to Clean a Very Dirty Floor

To clean a very dirty floor, follow this procedure:

1. Put water and cleaning chemical into the solution tank.
2. Activate the flow of solution by turning the solution control knob to the right and move the machine in a straight and steady direction. You are not removing the solution in this pass.
3. After the solution has set on the floor long enough to start cleaning, repeat the pass with the squeegee in the lowered position.
4. If the floor remains dirty, repeat the passes following the steps outlined in "Operating the Machine".

MAINTENANCE

 **DANGER:** Maintenance and repairs performed by unauthorized personnel could result in damage or injury. Maintenance and repairs must be done by authorized Clarke Technology personnel only.

 **DANGER:** Operating a machine that is not completely or fully assembled could result in injury or property damage. Do not operate this machine until it is completely assembled. Inspect the machine carefully before operation. Keep all fasteners tight.

 **DANGER:** Wearing jewelry such as watches, rings, etc. while performing any battery maintenance can cause severe burns. Never wear jewelry while performing battery maintenance.

 **WARNING:** Severe injury could occur to your hands if maintenance or repairs are performed on the chain or sprocket when the machine is on or plugged into the power supply. Always turn off power before attempting any service and/or maintenance.

 **WARNING:** SEVERE bodily injury could occur if operator leans body under the tank support to perform maintenance. Always position the tank support all the way over and rest it on the floor before attempting any service and/or maintenance.

 **WARNING:** Moving parts can cause injury to feet and hands. Keep feet and hands clear from under the machine.

 **WARNING:** Attempting maintenance and or repairs to this machine before emptying the solution or recovery tank could result in machine or property damage.

MAINTENANCE (cont'd)

Procedures to be Performed Before Work is Begun

Keep the machine clean. It will need fewer repairs and have a longer life.

1. Unplug charger from the wall.
2. Disconnect the connector on the battery charger from the connector on the batteries. See figure 23.
3. Join the connector from the batteries to the connector on the tank support. See figure 24.
4. Make sure the recovery tank cover is in place.
5. Check the solution tank screen and clean if necessary. See figure 25.
6. Make sure the vacuum screen is clean and in position in the front of the recovery tank. See figure 26.
7. Make sure the solution and recovery drain hoses are in position on the back of the machine. See figure 27. Secure the hose drain plugs.
8. Make sure the bumper skirt is in position. The bumper skirt prevents solution from flowing from under the frame.
9. Make sure the brush is in position.
10. Make sure the vacuum hose is installed and on the squeegee. See figure 28 on page 17.

Procedures to be Performed at the End of Work

1. Disconnect machine from power source.
2. Drain and flush the tanks. To drain the recovery and solution tanks, follow this procedure:
 - a. Remove the drain hose from the fitting on the back of the machine.
 - b. Put the end of the hose over a drain or bucket.
 - c. Run clean water into the solution and recovery tanks to flush the tanks.
 - d. Put the end of both hoses over a drain or bucket.

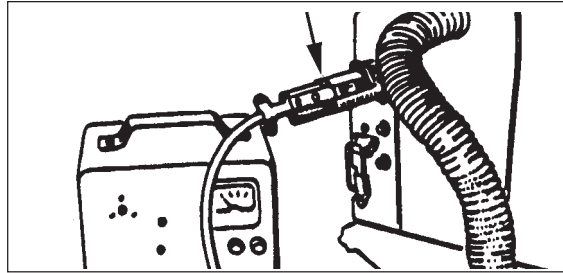

Figure 23

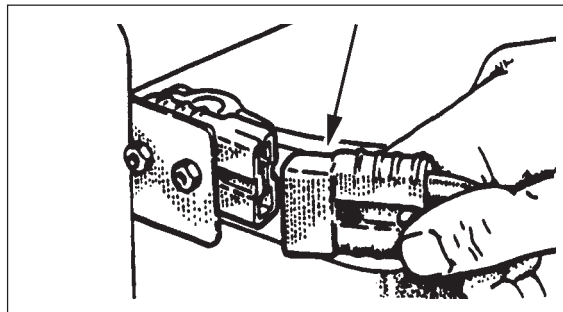

Figure 24

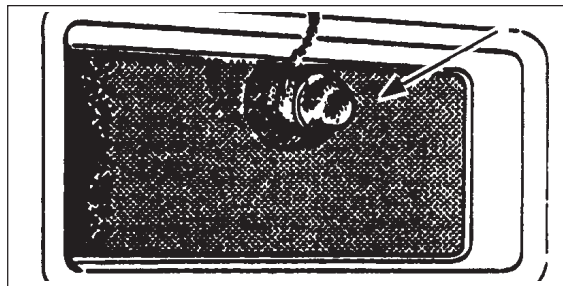

Figure 25

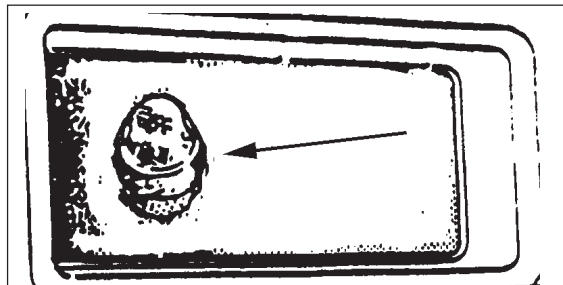

Figure 26

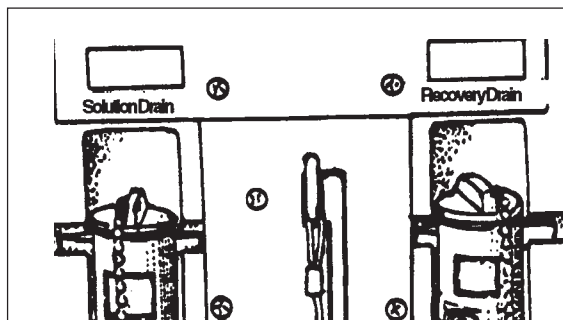

Figure 27

MAINTENANCE (cont'd)

3. Leave the tanks and the drain hoses open to dry in the air.
4. Check and clean the squeegee blade. Use a soft cloth to clean the squeegee blade. If the squeegee blade is damaged or worn, turn or replace the blade.
5. Check and clean the vacuum gaskets, the vac screen filter and the solution screen filter. Remove and clean with a vinegar-water solution or warm soapy water. Rinse the parts in clean water.



WARNING: Lead acid batteries generate gases which can cause an explosion. **NO SMOKING.** Always wear eye protection and protective clothing when working near batteries.

6. Check the batteries and add distilled water as needed. The plates must be covered before charging. After charging, check to be sure that the correct level is to within 1/4 of the bottom of the tube in each cell.
7. Charge the batteries. See the instructions in the section of this book called "How to Charge the Batteries".
8. Use a clean cloth and wipe the surface of the machine.
9. Remove the brush or pad driver. Rinse clean and allow to dry. Discard the pad if necessary.
10. Store the machine and accessories in a dry building.

NOTE: Grease axle assembly wheels once a week.

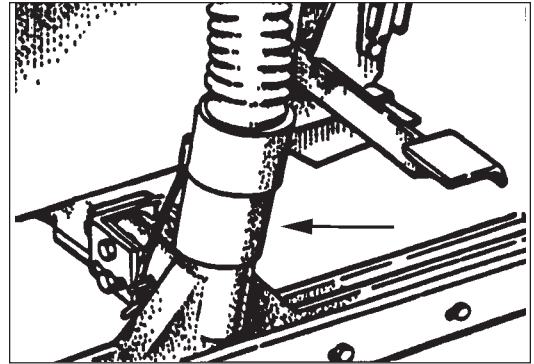

Figure 28

MAINTENANCE (cont'd)

Weekly Maintenance

Use a grease gun to lightly lubricate the drive wheels and casters. Access to the drive wheels is through the access hole in the skirt. Access to the casters is from the rear of the machine.

Battery Maintenance

The electrical power to operate the machine comes from the storage batteries. Storage batteries need preventative maintenance.

⚠ WARNING: Working with batteries can be dangerous. Always wear eye protection and protective clothing when working near batteries. **NO SMOKING!**

To maintain the batteries in good condition, follow these instructions:

1. Keep the electrolyte at the correct level. The correct level is between 1/4" below the bottom of the tube in each cell and above the tops of the plates. Check the level of the electrolyte each time you charge the batteries. See figure 29.

NOTE: Check the level of electrolyte prior to charging the batteries. Be sure the plates in each cell are covered with electrolyte. Do not top off the cells prior to charging the battery. Electrolyte expands during charging. As a result, the electrolyte could overflow from the cells. Always top off the cells with distilled water after charging.

⚠ CAUTION: Irreversible damage will occur to the batteries if the electrolyte level does not cover the plates. Keep the electrolyte at the correct level.

⚠ CAUTION: Machine damage and discharge across the tops of the batteries can occur if the batteries are filled above the bottom of the tube in each cell. Do not fill the batteries up to the bottom of the tube in each cell. Wipe any acid from the machine or the tops of the batteries. Never add acid to a battery after installation.

⚠ CAUTION: Tap water may contain contaminants that will damage batteries. Batteries must be refilled with distilled water only.

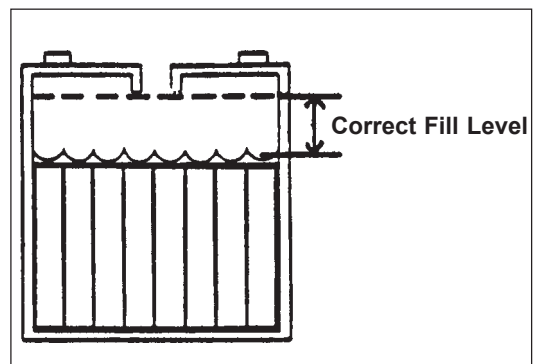

Figure 29

MAINTENANCE (cont'd)

2. Keep the tops of the batteries clean and dry. Keep the terminals and connectors clean. To clean the top of the batteries, use a damp cloth with a weak solution of ammonia or bicarbonate of soda solution. To clean the terminals and connectors, use a terminal and connector cleaning tool. Do not allow ammonia or bicarbonate of soda to get into batteries.
3. Keep the batteries charged.

How to Charge the Batteries

⚠ WARNING: Charging the batteries in an area without adequate ventilation could result in an explosion. To prevent an explosion, charge the batteries only in an area with good ventilation.

⚠ WARNING: Lead acid batteries generate gases which could explode. Keep sparks and flames away from batteries. **NO SMOKING.**

⚠ WARNING: Failure to disconnect the AC plug from the wall receptacle before connecting or disconnecting the DC connector on the charger could result in an explosion. Always disconnect the AC plug from the wall receptacle before connecting or disconnecting the DC connector on the charger.

To charge the batteries, follow this procedure:

1. Put the charger on a flat surface. Make sure the vents on the sides are at least two inches away from walls and other objects. Make sure there are no objects near the vents on the bottom of the charger.
2. Disconnect the battery pack connector from the control housing connector. See figure 30.
3. Connect the DC connector on the charger to the battery pack connector. See figure 31.
4. Connect the charger to a properly grounded single phase (3-wire) wall receptacle having the voltage, frequency, and ampere capacity specified on the nameplate of the charger.

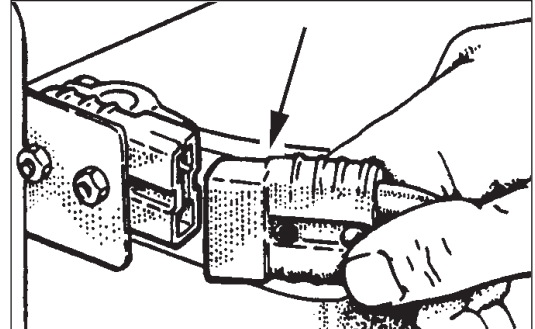

Figure 30

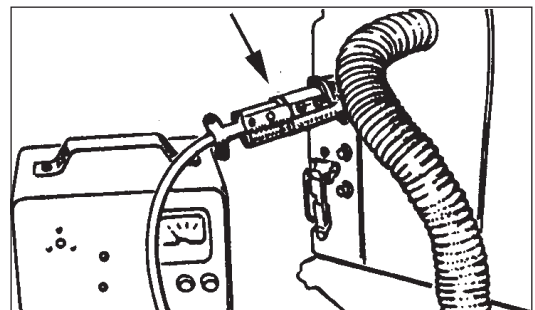

Figure 31

For more instruction on the use of the charger, read the instruction book supplied with the charger.

CLARKE TECHNOLOGY
Vision 17B
Machine Variables

Vision 17 BT										Vision 17B										CODE NUMBER					
00394B Serial # XE to ...	00394A Serial # ... to XE	00394A Serial # XE to ...	00394B Serial # ... to XE	00393B Serial # XE to ...	00393B Serial # ... to XE	00393A Serial # XE to ...	00393A Serial # ... to XE	00392B	00392A	00391B	00391A	00390E	00384B Serial # XE to ...	00384A Serial # XE to ...	00384A Serial # ... to XE	00383B Serial # XE to ...	00383B Serial # ... to XE	00383A Serial # XE to ...	00383A Serial # ... to XE		00382A	00381B	00381A	00380E	
																								x	00380E Vision 17B with Brake
													x	x	x	x	x	x	x	x	x	x	x		00380A Vision 17B Machine
												x													00390E Vision 17BT with Brake
x	x	x	x	x	x	x	x	x	x	x	x														00390A Vision 17BT Machine
				x	x	x	x			x	x					x	x	x	x			x	x		51436B Poly Brush
x	x	x	x										x	x	x					x	x				53126B Pad Driver
									x		x										x		x		871376 12V 95 AH Wet Battery
									x	x										x		x			871377 12V 95 AH Dry Battery
	x		x		x		x							x		x		x							40703A Battery Recom. 80 AH
x	x		x		x								x		x		x								40070A 12V Gel Battery
									x	x										x		x			14661B Battery Cable Kit
									x	x											x		x		41206A 16" Series Cable
									x	x											x		x		41215A Power Battery Cable Post Style
x	x	x	x	x	x	x	x						x	x	x	x	x	x	x						41216A Power Battery Cable Ring Style
x	x	x	x	x	x		x						x	x	x	x	x	x	x						41217A Battery Series Cable Ring Style
			x				x		x		x				x					x		x			40510A or 40520A Charger 120V AC
	x			x			x		x					x						x		x			40511A or 40521A Charger 230V AC
		x					x								x			x							40071A 100-125V Gell Charger
x			x										x			x									40072A 230-250V Gell Charger
x	x	x	x	x	x	x	x						x	x	x	x	x	x	x						170854 5/16 - 18 Hex Nut (4)
x	x	x	x	x	x	x	x						x	x	x	x	x	x	x						85813A 5/16 - 18 x 1 Hex Screw (4)
x	x	x	x	x	x	x	x						x	x	x	x	x	x	x						980652 5/16 Lock Washer (4)

NOTE:
40703A Use Wet Style Charger only
40070A Use Gel Style Charger only

CLARKE TECHNOLOGY
Vision 17B
Machine Accessories 6/02

Accessories:

<u>Part No.</u>	<u>Description</u>
51436B	Brush, Polypropylene
53126B	Pad Driver
50527A	Big Mouth Base
56927A	Big Mouth Retainer
50477A	Clutch Plate for Pad/Brush
962819	Clutch Plate Screws
51437B	Nylon Scrub Brush .028 Dia. Bristles
51439B	Grit Scrub Brush Assembly
682408	Hose Connector - connects 1½" diameter hose to machine
674114	10' x 1½" red spiral lock deluxe hose
639804	1½" double curved aluminum wand
638828	Aluminum 14" squeegee pick up tool
638856	Aluminum combination scrubbing brush & squeegee pick-up tool
51469B	Nylon Scrub Brush .016 Dia. Bristles
51481A	Grit-Lite Brush◆
10773A	Kit, Parking Brake
14661B	Standard Battery Cable Kit
18800A	Squeegee Asm.

NOTE: ◆ indicates that a change has occurred since the last publication of this manual.

PADS BY CASE

<u>Color</u>	<u>Vision 17</u>	<u>Color</u>	<u>Vision 17</u>
Yellow	979169	Green	976157
White	976052	Brown	976055
Red	976053	Black	976158
Blue	976054		



Vision 17B/BT
Section II
Parts and Service Manual

(78454B)

HOW TOO CORRECT PROBLEMS IN THE MACHINE

PROBLEM	CAUSE	ACTION
There isn't any solution flow.	<p>The solution tank is empty.</p> <p>The solution knob is turned too far to the left.</p> <p>There is an obstruction in the hose or filter.</p> <p>The solution valve or linkage is damaged.</p>	<p>Fill the solution tank.</p> <p>Turn the solution knob to the right.</p> <p>Remove the obstruction from hose or filter.</p> <p>Repair or replace the valve or the linkage.</p>
The solution flow does not stop.	<p>The solution valve is open.</p> <p>The solution valve or linkage is damaged.</p> <p>The solution valve is dirty.</p> <p>There is a damaged seat and washer in the solution valve.</p> <p>The valve stem is dirty.</p>	<p>Close the solution valve.</p> <p>Repair or replace the valve or the linkage.</p> <p>Clean the solution valve.</p> <p>Replace the valve.</p> <p>Clean and lubricate the valve stem.</p>
The machine does not remove any water from the floor.	<p>The squeegee is up.</p> <p>The vacuum motor is not running.</p> <p>The vacuum motor switch is defective.</p> <p>The recovery tank is full.</p> <p>The vacuum shut-off float circuit is open.</p> <p>The vacuum filter screen is dirty.</p> <p>There is an obstruction in the vacuum tube.</p> <p>There is an obstruction or damage in the squeegee, vacuum hose or standpipe.</p> <p>The squeegee hose is disconnected.</p>	<p>Lower the squeegee.</p> <p>Put the switch in the "ON" position.</p> <p>Have an authorized Clarke Technology person make repairs.</p> <p>Drain the tank.</p> <p>Recovery tank is full. Empty the tank.</p> <p>Clean or replace the filter screen.</p> <p>Remove the obstruction.</p> <p>Remove the obstruction or repair the damage.</p> <p>Connect the hose.</p>
The machine does not remove all the water from the floor.	<p>The squeegee blades are damaged, worn, or incorrectly installed.</p> <p>There is an obstruction or damage in the squeegee, vacuum hose or standpipe.</p> <p>The filter screen is dirty.</p> <p>The gasket on the cover of the recovery tank are damaged.</p> <p>Defective vacuum motor.</p>	<p>Turn or replace the squeegee blade.</p> <p>Correctly install the squeegee blade.</p> <p>Remove the obstruction or repair the damage.</p> <p>Clean or replace the filter screen.</p> <p>Replace the gasket.</p> <p>Have an authorized Clarke Technology person make repairs.</p>
The batteries do not give the normal running time.	<p>The battery terminals are dirty or damaged.</p> <p>The electrolyte level is too low.</p> <p>The batteries are not fully charged.</p> <p>The charger is damaged.</p> <p>The battery is defective.</p>	<p>Clean the terminals and connectors.</p> <p>Replace the damaged cables. Charge the batteries.</p> <p>Add distilled water to each cell and change the batteries.</p> <p>Charge the batteries for a full 16 hours.</p> <p>Have an authorized person repair the charger.</p> <p>Replace the batteries.</p>
The cleaning is not even.	<p>The scrub brush or pad are worn.</p> <p>There is damage to the brush assembly casters or to the solution valve.</p> <p>The motor is not running.</p>	<p>Replace the scrub brush or pad.</p> <p>Have an authorized service person make the repairs.</p> <p>Repair the wiring, replace the switch, Service the motor, circuit breaker and the contractor.</p>

CLARKE TECHNOLOGY
Vision 17B
Machine #00380B, 24V Battery, Machine Assembly - 3/00

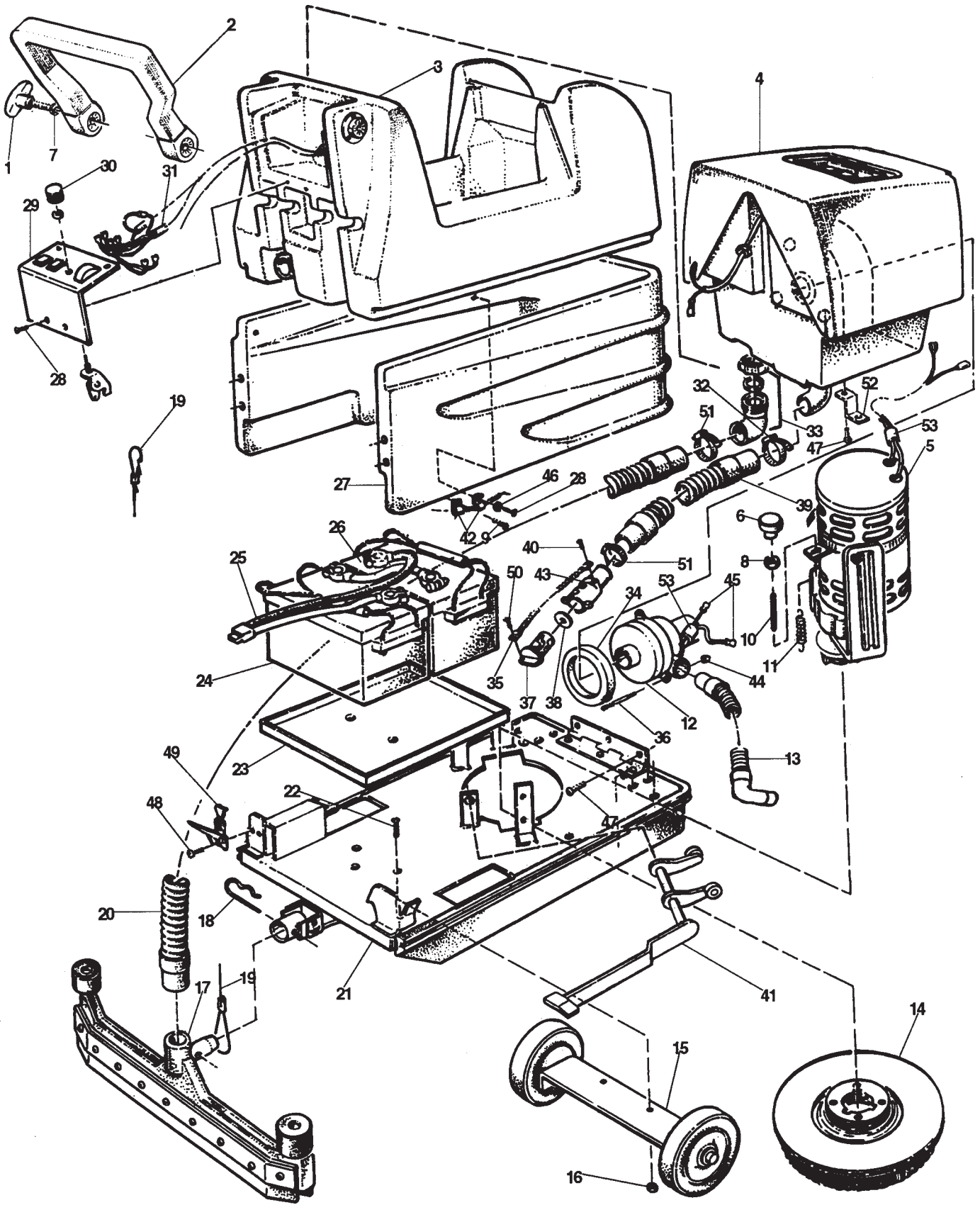

CLARKE TECHNOLOGY
Vision 17B-Battery Model 24V Battery
Machine Assembly Parts List - 1/02

Ref	Part No.	Description	Qty
1	55531A	Knob, Handle	2
2	34804A	Handle	1
3	Page 36	ASM Solution Tank	1
4	Page 37	ASM Recovery Tank	1
5	Page 32	ASM Brush Motor	1
6	65300A	Knob	1
7	980431	Washer ¼ - 7/8 S.S.	4
8	81111A	Nut 3/8 X 16	2
9	962981	Screw	1
10	68004A	Stud	1
11	818381	Spring	1
12	44917A	Motor, Vacuum	1
13	30448A	Hose, Exhaust Vacuum	1
14	Page 21	Brush or Pad Driver	1
15	Page 30	Asm. Non Traverse	1
16	920110	Nut 5/16 - 18 Elastic Stop	2
17	Page 37	Asm. Squeegee	1
18	66515A	Pin Locking	1
19	61664A	Cable, Squeegee	1
20	30407B	Hose, Squeegee	1
21	Page 33	Asm. Mainframe Weldment	1
22	84238A	Screw, 5/16-18 x 3/4	3
23	39004A	Battery, Tray	1
24	Page 20	Battery	2
25	Page 20	Cable, Battery	1
26	Page 20	Cable, Battery Series	1
27	Page 40	Asm. Support Tank	1
28	84237A	Screw 10-32 x ½ Pan Hd	6
29	Page 35	Asm. Control Pad	1
30	55502A	Knob-Solution Control	1
31	49728A	Harness, Control	Ref
32	752020	Clamp, Hose	1
33	53630A	Elbow, Recovery	1
34	643418	Gasket Vacuum Motor	1
35	52206A	Chain-Cover	1
36	58533A	Spacer, Vac Motor	3
37	833901	Handle, Drain Valve	1
38	833407	Gasket, Drain	1
39	30415A	Hose Recovery Drain	1
40	962943	Screw	1
41	Page 32	Asm. Lift Brush	1
42	832102	Clamp, Solution Cable	2
43	839401	Valve, Drain	1
44	81104A	Nut, ¼ - 20 Nylock	6
45	47905A	Terminal	2
46	87026A	Washer	2
47	85395A	Screw ¼ -20 x ½	7
48	85509A	Screw 6-32	4
49	755161	Latch	2
50	962987	Screw	1
51	832002	Clamp, Plastic	1
52	61224A	Bracket, Recovery	2
53	47202A	Suppressor, EMI	2
NI	699202	Wire Ties	6
NI	77049A	Label, Squeegee Lift	1
NI	77053A	Tag, Instruction	1
NI	77077A	Plate, Warning Head	1
NI	77233A	Label, C. E.	1

CLARKE TECHNOLOGY
Vision17 BT

Model #00390A, 24V Battery Machine Assembly Drawing - 3/00

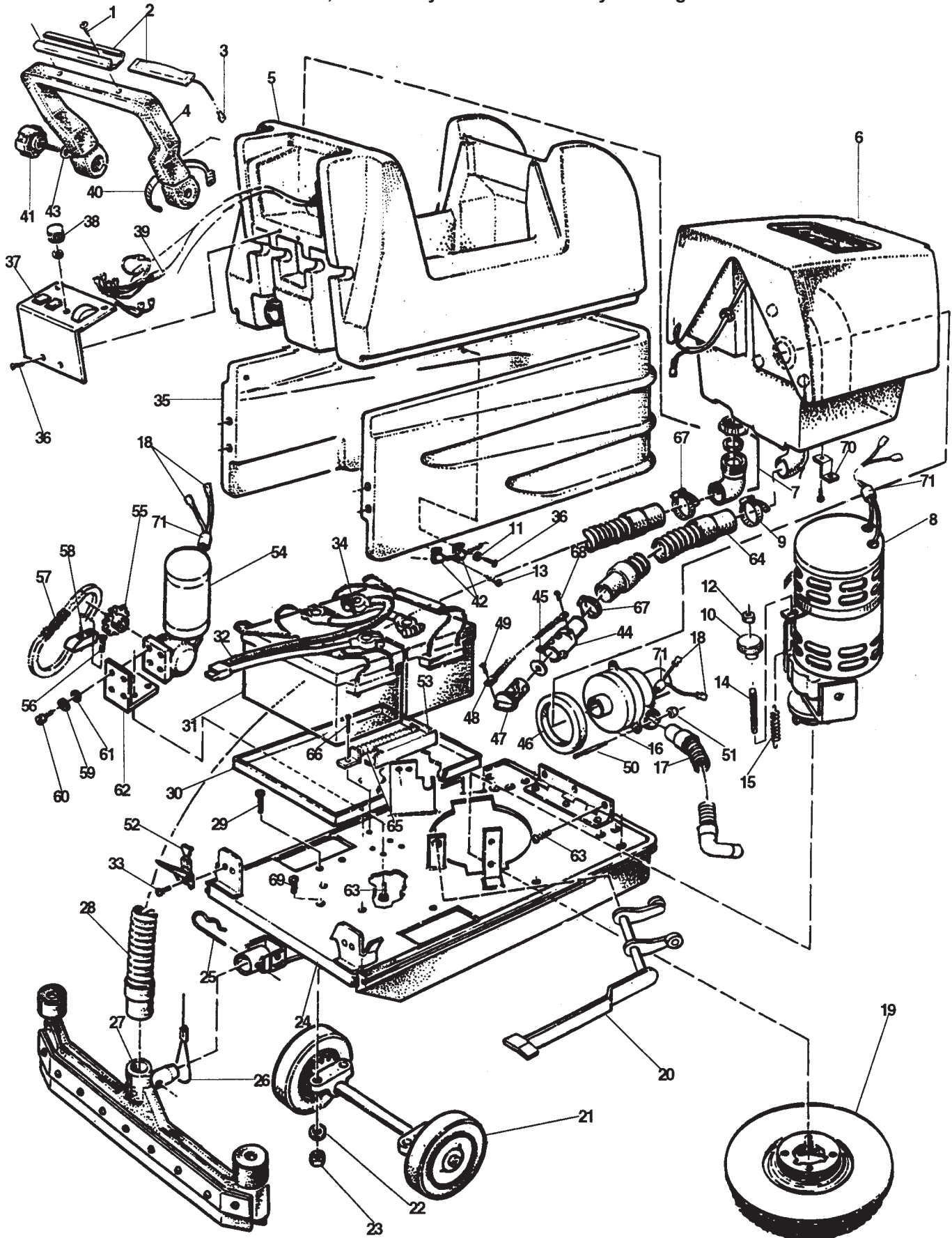

CLARKE TECHNOLOGY
Vision 17 - BT Model 24V Battery
Machine Assembly Parts List - 1/02

Ref	Part No.	Description	Qty
1	962738	6-32 x 5/8 Screw	2
2	47377A	Switch, Traverse	1
3	47708A	Terminal	2
4	34806A	Handle, Control	1
5	Page 38	ASM, Solution Tank	1
6	Page 39	ASM, Recovery Tank	1
7	53630A	Elbow, Recovery	1
8	Page 34	ASM, Brush Motor	1
9	752020	Clamp Hose	1
10	65300A	Knob	1
11	87026A	Washer	1
12	81111A	Nut, 3/8 x 16	1
13	962981	Screw	1
14	68004A	Stud	1
15	818381	Spring	1
16	44917A	Motor, Vacuum	1
17	30448A	Hose, Exhaust Vacuum	1
18	47905A	Terminal	2
19	Page 21	Brush or Pad Driver	1
20	Page 32	Asm, Brush Lift	1
21	Page 31	ASM, Traverse Axle	1
22	87027A	Washer 5/16 S.S. Flat	4
23	920110	Nut 5/16 - 18 Elastic	4
24	Page 33	ASM, Main Frame	1
25	66515A	Pin, Locking	1
26	61664A	Cable, Squeegee	1
27	Page 37	ASM, Squeegee	1
28	30407B	Hose, Squeegee	1
29	84239A	Screw, 5/16 Flat	4
30	39004A	Battery, Tray	1
31	Page 20	Battery	2
32	Page 20	Cable, Battery	1
33	85509A	Screw 6-32	4
34	Page 20	Cable, Battery Series	1
35	Page 41	ASM, Tank Support	1
36	84237A	Screw 10 -32 x 1/2 Pan	6
37	Page 36	ASM, Control Panel	1
38	55502A	Knob, Solution Control	1
39	49730A	Harness Control	1

Ref	Part No.	Description	Qty
40	58901A	Tie, Wire	2
41	55531A	Knob, Handle	2
42	832102	Clamp, Solution Cable	2
43	980413	Washer	4
44	839401	Valve, Drain	1
45	833407	Gasket, Drain	1
46	643418	Gasket, Motor Vacuum	1
47	833901	Handle, Drain Valve	1
48	52206A	Chain, Cover	1
49	962987	Screw	1
50	58533A	Spacer, Motor Vac	1
51	81104A	Nut, 1/4 -20 Nylock	6
52	755161	Latch	2
53	62644A	Cover, Resistor	1
54	45031C	Motor, Traverse	1
55	58707A	Sprocket	1
56	84233A	Screw	2
57	52208A	Chain #35	1
58	37014A	Pad, Chain Tension	1
59	980657	Washer 1/4 Lock	4
60	85391A	Screw 1/4 -20 x 5/8 S.S.	4
61	980646	Washer	4
62	61261A	Bracket, Traverse Motor	1
63	85395A	Screw 1/4 -20 x 1/2 S.S.	9
64	30415A	Hose, Drain	1
65	46506A	Resistor	1
66	85519A	Screw 1/4 - 20	2
67	832002	Clamp, Plastic	2
68	962943	Screw	1
69	84238A	Screw 5/16 - 18 x 3/4	1
70	61244A	Bracket, Recovery	2
71	47202A	Suppressor, EMI	3
NI	699202	Wire Tie	6
NI	77049A	Label, Squeegee Lift	1
NI	77053A	Tag, Instruction	1
NI	77076A	Plate, Warning (Hands)	1
NI	77077A	Plate, Warning (Head)	1
NI	77233A	Label, C. E.	1

CLARKE TECHNOLOGY
Vision 17B
ASM, Non Traverse Axle
Drawing & Parts List 11/98
Form #10510A

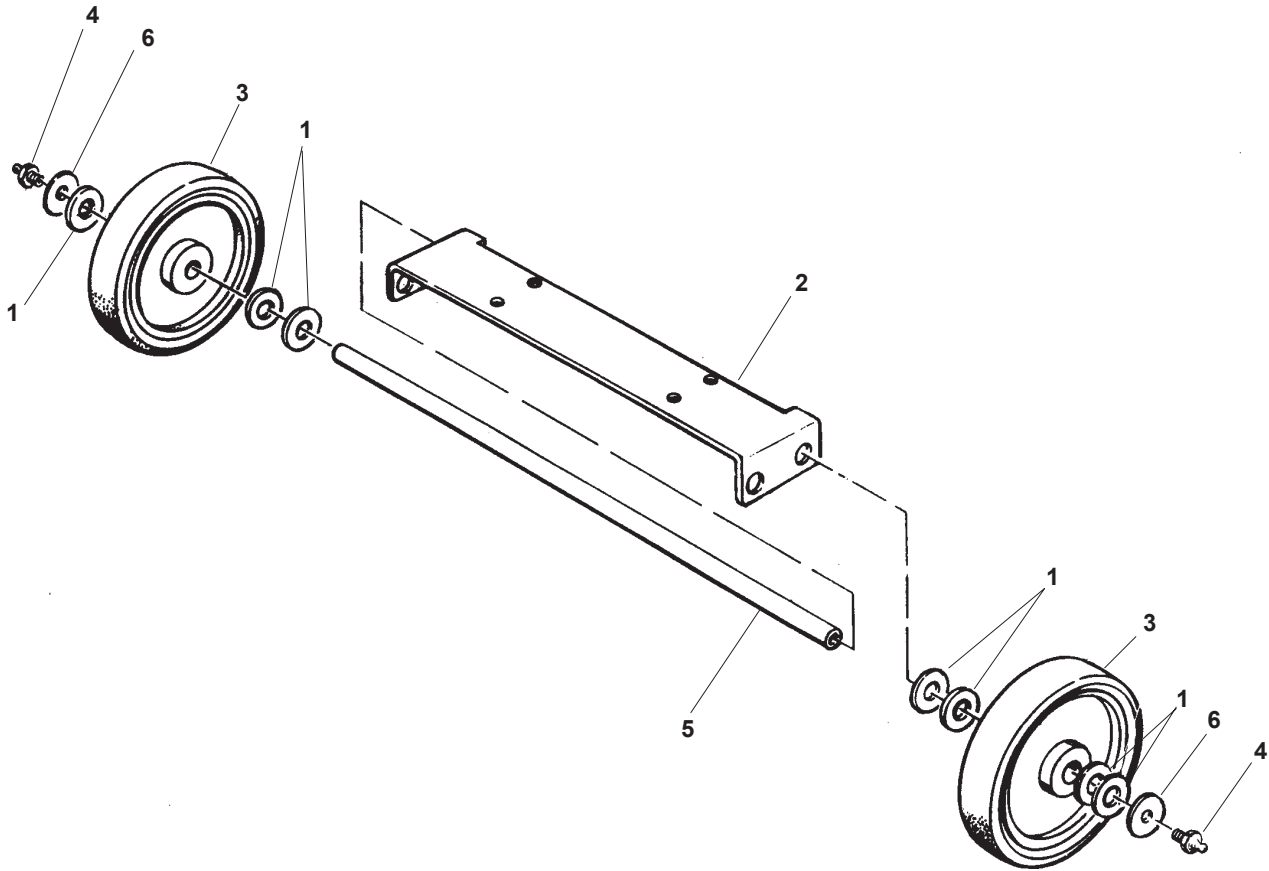

Ref	Part No.	Description	Qty
1	87613A	Washer, Nylon 5/8	7* Nominal
2	61247A	Bracket, Axle	1
3	59936C	Wheel	2
4	54014A	Fitting, Grease, 1/4"-20	2
5	60196A	Shaft	1
6	87039A	Washer, Fender 1/4" SS	2

NOTE: Place washers as required to center the wheels
 (Number of washers may vary)

NOTE: Grease wheels once a week.

CLARKE TECHNOLOGY
Vision 17BT
ASM, Traverse Axle
Drawing & Parts List 11/98
Form#10512A

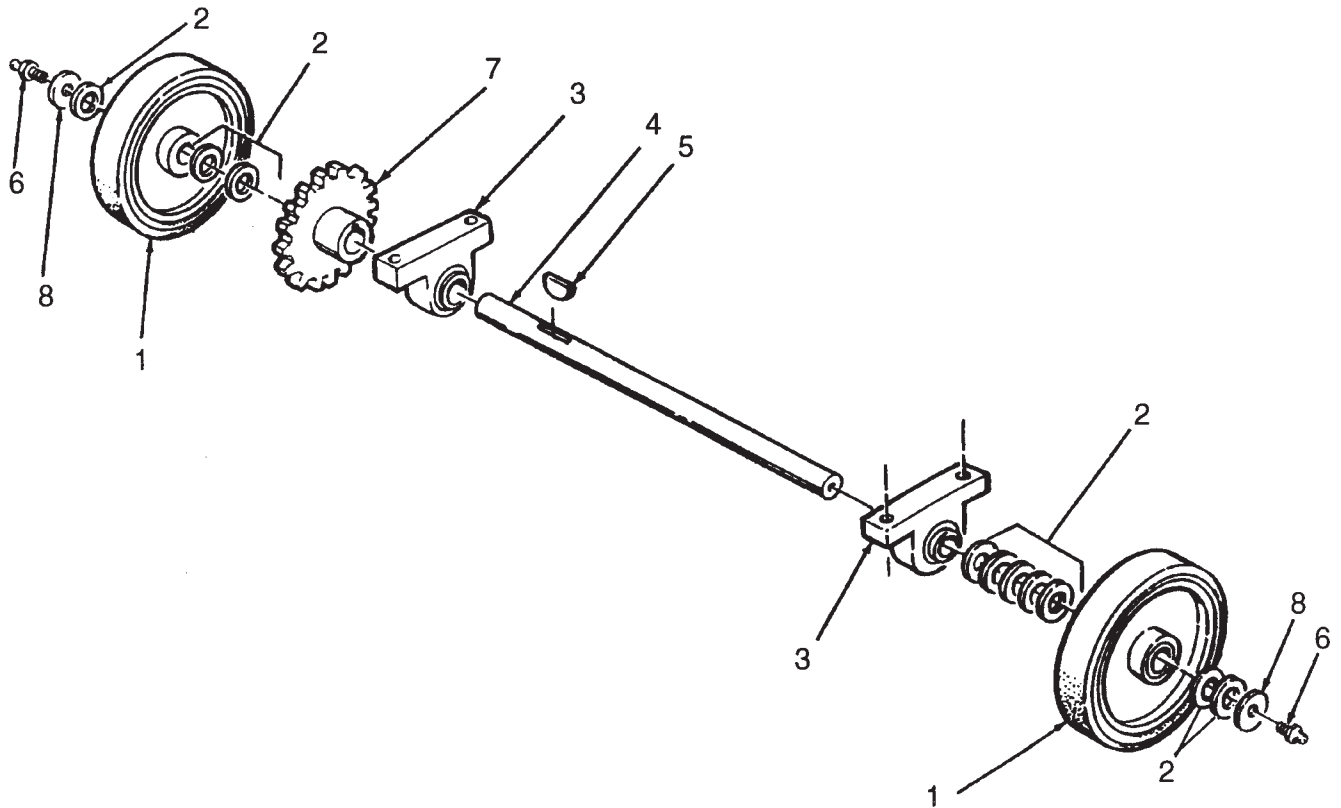

Repair Parts for 59935C Wheel:

<u>Part No.</u>	<u>Description</u>	<u>Qty.</u>
58154A	Seal	2
51187A	Roller Clutch Bearing	2

Repair Parts for 59935B Wheel:

<u>Part No.</u>	<u>Description</u>	<u>Qty.</u>
58146A	Seal	2
51187A	Roller Clutch Bearing	2

<u>Ref</u>	<u>Part No.</u>	<u>Description</u>	<u>Qty</u>
1	59935C	Wheel, Traverse	2
*2	87613A	Washer, Nylon	10
3	51175A	Bearing, Pillow Block	2
4	60503A	Axle, Traverse	1
5	80504A	Key, 605 S & L	1
6	54014A	Fitting, Grease	2
7	58711A	Sprocket	1
8	87039A	Washer, Fender 1/4"	2

*NOTE: Place washers as required to center the wheels
 (Number of washers may vary)

NOTE: Grease wheels once a week.

CLARKE TECHNOLOGY
 Vision 17B/BT
 Brush Lift Drawing Assembly & Parts List 11/98
 Form #16608A

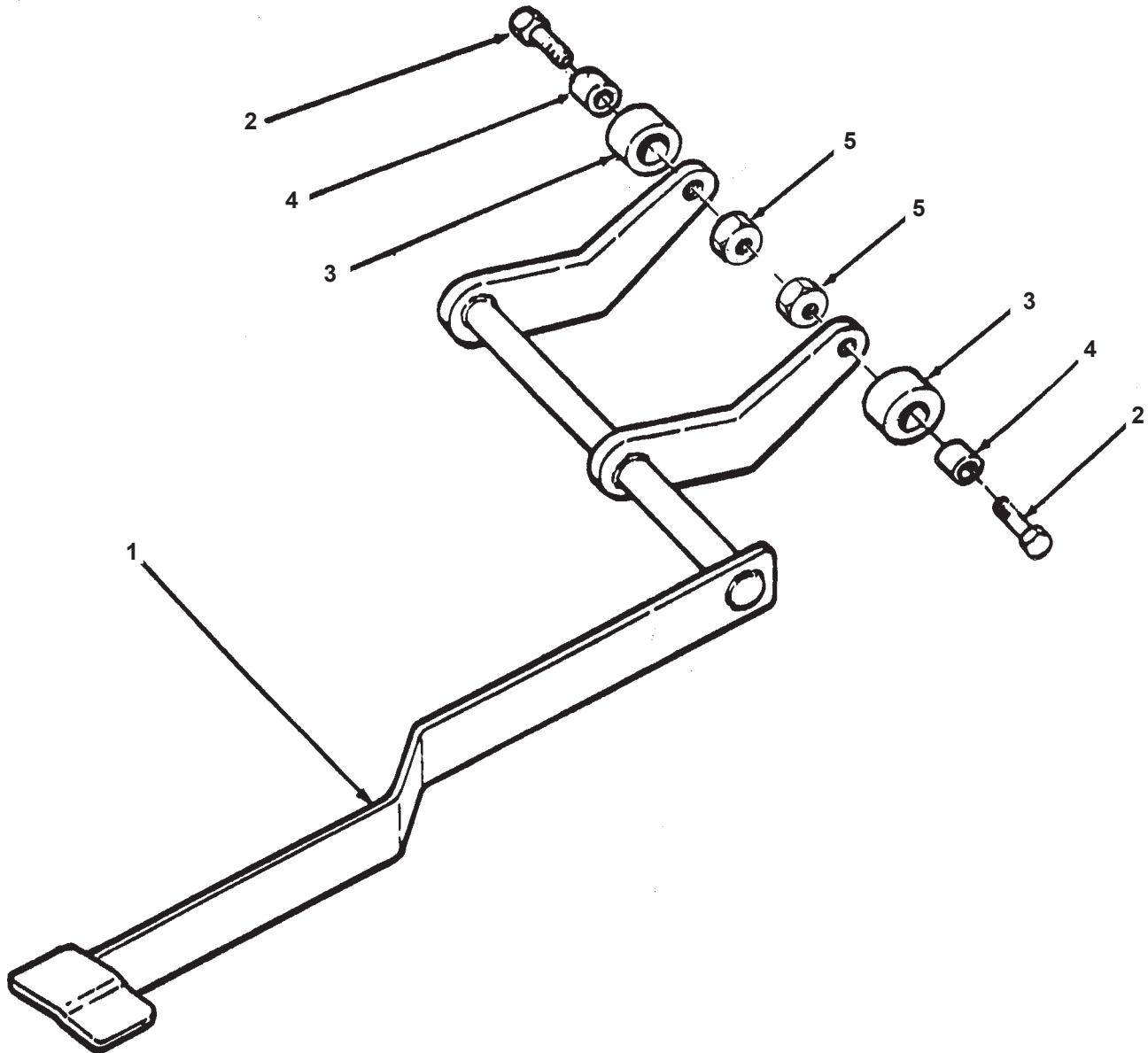

Ref	Part No.	Description	Qty
1	65424A	Lift Brush, Weldment	1
2	85600A	Screw 1/4 - 20	2
3	51516A	Bushing	2
4	608210	Spacer, Handle, Bolt	2
5	920208	Nut, 1/4-20	2

CLARKETECHNOLOGY
Vision 17B/BT
ASM, Main Frame Drawing & Parts List - 11/98
Form #16926B

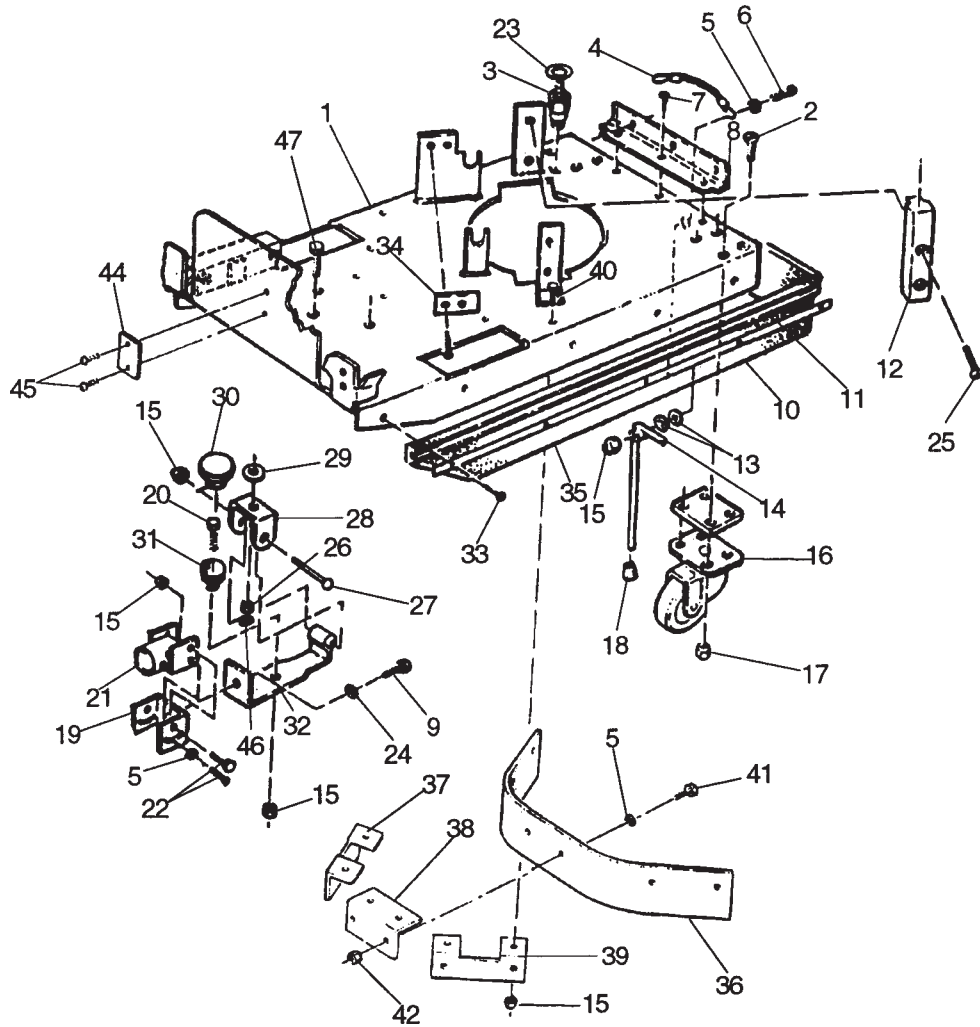

Ref	Part No.	Description	Qty	Ref	Part No.	Description	Qty
1	60021A	Weldment, Main Frame	1	25	84233A	Screw 1/4 - 20 Flat	6
2	84239A	Screw 5/16-18 x 1 Flat Hd SS	6	26	67867A	Nut, Squeegee Spacer	1
3	53618A	Adapter 3/8 X 3/8	1	27	85396A	Screw	1
4	64456A	Handle	1	28	61252A	Bracket, Swing Squeegee	1
5	87026A	Washer, S.S. 1/4" Flat	15	29	87027A	Washer	1
6	85384A	Screw 1/4 - 20 X 1 1/2	2	30	30517A	Bushing Squeegee	1
7	85395A	Screw 1/4 - 20 X 1/2	7	31	58612A	Spring, Squeegee	1
8	64505A	Hinge Tank	1	32	68730B	Bracket, Arm Weldment	1
9	85822A	Screw 3/8-16 x 7/8	1	33	85397A	Screw, 10-24 x 3/8 SS	12
10	31227A	Skirt, Main Frame	1	34	66939A	Retainer, Motor Pivot	1
11	66960A	Retainer, Skirt	2	35	66961A	Retainer, Skirt	2
12	38009A	Guide, Plastic	3	36	33504A	Center Flap	1
13	980442	Wave Washer	2	37	69470A	Bracket, Left Flap	1
14	68733B	Kick Stand	1	38	69469A	Bracket, Center Flap	1
15	81104A	Nut 1/4 - 20 Nylock	12	39	69468A	Bracket, Right Flap	1
16	52117A	Caster, Swivel	2	40	962098	Screw, 1/4 - 20 x 3/4	6
17	920110	Nut, 5/16 - 18 Elastic	6	41	962798	Screw, 10 - 24 x 3/8 SS	11
18	52047A	Cap	1	42	81110A	Nut, 10 - 24 Hex	11
19	69028A	Wldmt. Squeegee Swivel	1	43	170854	Nut, 5/16 - 18	1
20	85391A	Screw 1/4 - 20	1	44	77261A	Tag	1
21	60698A	Squeegee, Bracket, Weldment	1	45	85509A	Screw	2
22	170915	Screw 1/4-20 x 3/4	4	46	81112A	Nut, 5/16 - 18 ESNA	1
23	722021	Clamp, Hose	1	47	84229A	Screw, 5/16 - 18 x .88	1
24	87614A	Washer 3/8 Int., Ext.	2	NI	See pg 42	Kit, Parking Brake STD on European Models	

CLARKE TECHNOLOGY
Vision 17B/BT
Brush Motor Assembly
Drawing and Parts List 3/00
Form #17116A

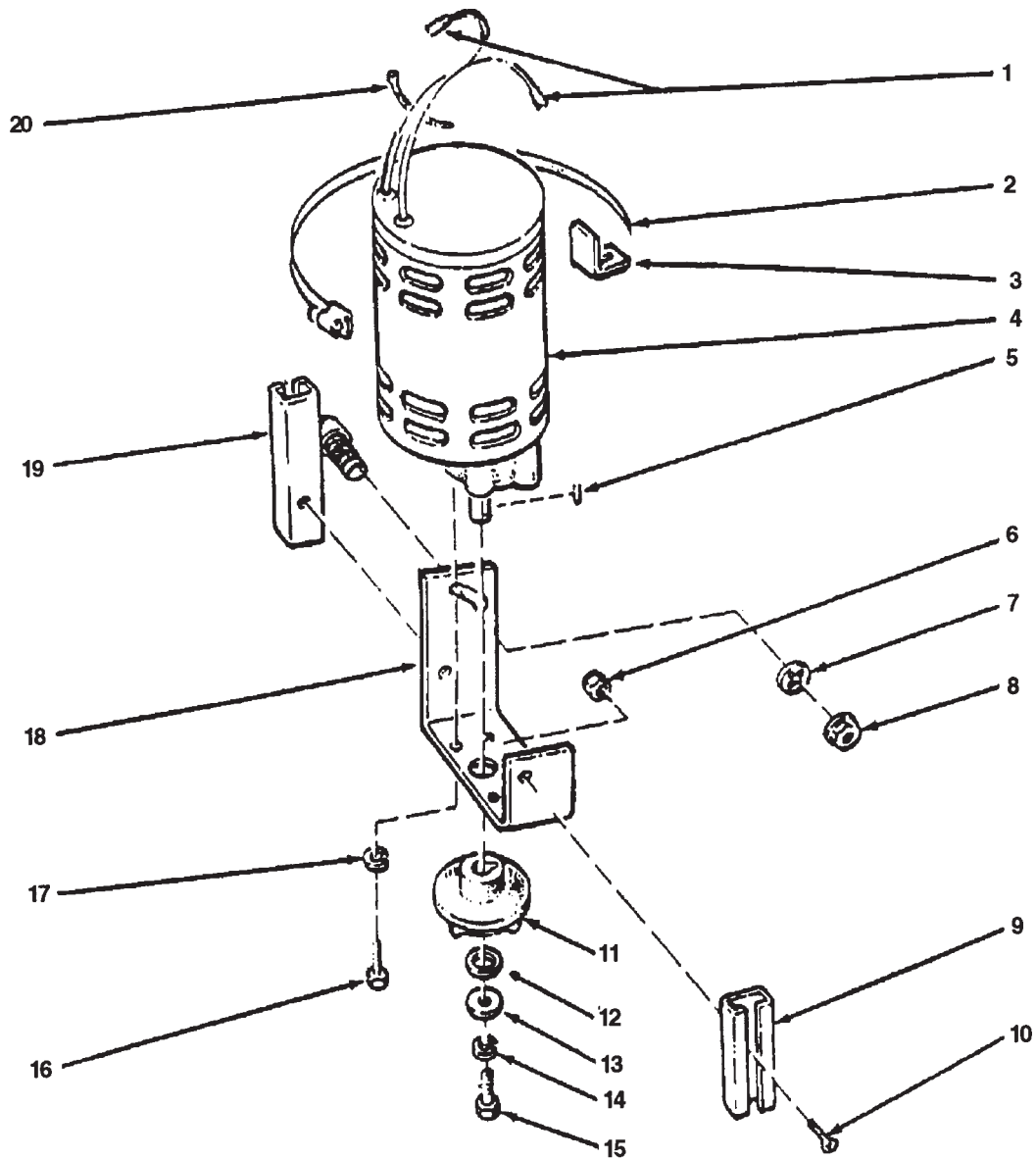

Ref	Part No.	Description	Qty
1	47710A	Terminal, Brush Motor	2
2	762005	Clamp	1
3	60670B	Bracket	1
4	44809A	Gear Motor 24V DC	1
	Page 43	Motor Parts Breakdown	
	Page 42	Gear Parts Breakdown	
5	915102	Key (included with #4)	1
6	81104A	Nut, 1/4 - 20 Nylock	2
7	980662	Washer	1
8	67865A	Spacer, Tilt Handle	1
9	63600A	Guide RH	1

Ref	Part No.	Description	Qty
10	84242A	Screw 1/4 -20 x 5/8	2
11	20308A	Adapter Motor	1
12	980679	Spacer Washer	1
13	980210	Washer Impeller	1
14	980652	Washer, Lock 5/16	1
15	85727A	Screw, 5/16 Hex	1
16	85389A	Screw, 3/8 - 16 x 5/8 Pan	4
17	980638	Lockwasher 3/8	4
18	61238A	Bracket, Motor Lift	4
19	68761A	Guide, LH	1
20	58901A	Tie, Wire	2

CLARKE TECHNOLOGY
Vision17B
Panel Assembly Non-Traverse Model
Drawing & Parts List 11/98
Form # 17641A

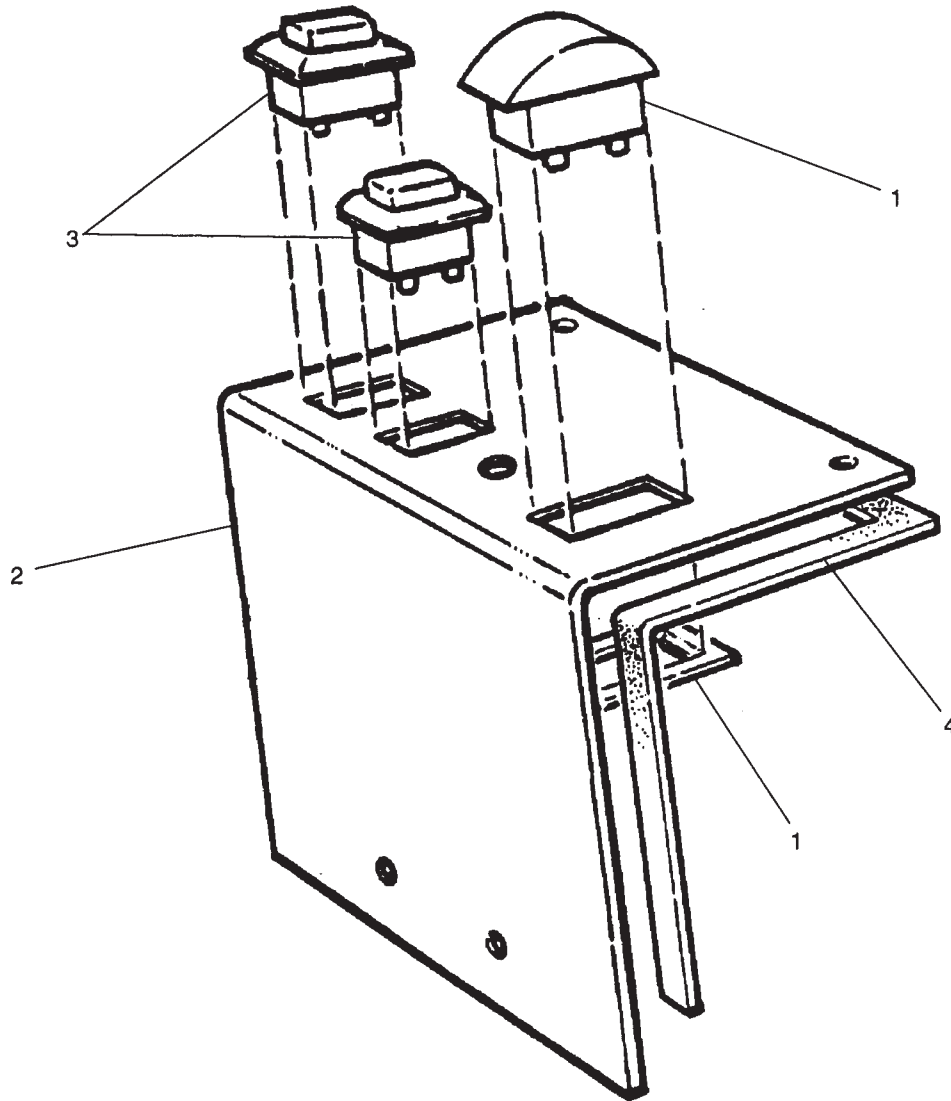

Ref	Part No.	Description	Qty
1	44405A	Meter, Battery	1
2	66179B	Panel, Control	1
3	47316B	Switch	2
4	54349A	Gasket	1

CLARKE TECHNOLOGY
Vision 17BT
Panel Assembly - Battery Traverse Model
Drawing and Parts List 11/98
Form #17640A

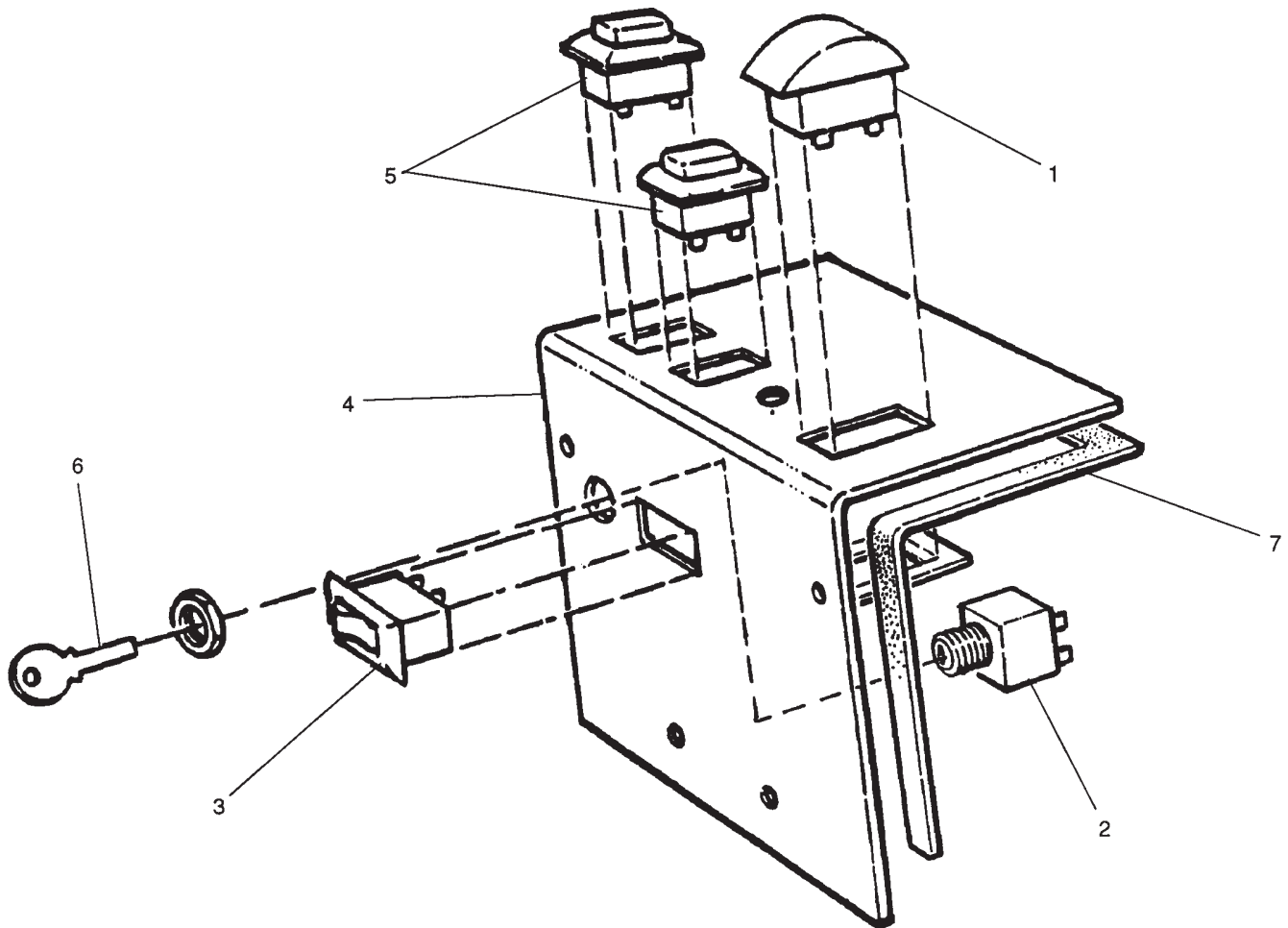

Ref	Part No.	Description	Qty
1	44405A	Meter, Battery	1
2	47380A	Switch, Key (Incl. 2 of item #6)	1
3	47304A	Switch, 3-Position	1
4	69806B	Panel, Control	1
5	47316B	Switch	2
6	55413A	Key	1
7	54349A	Gasket	1

CLARKE TECHNOLOGY
Vision 17B/BT
Squeegee Assembly Drawing & Parts List 11/98
Form#18809A

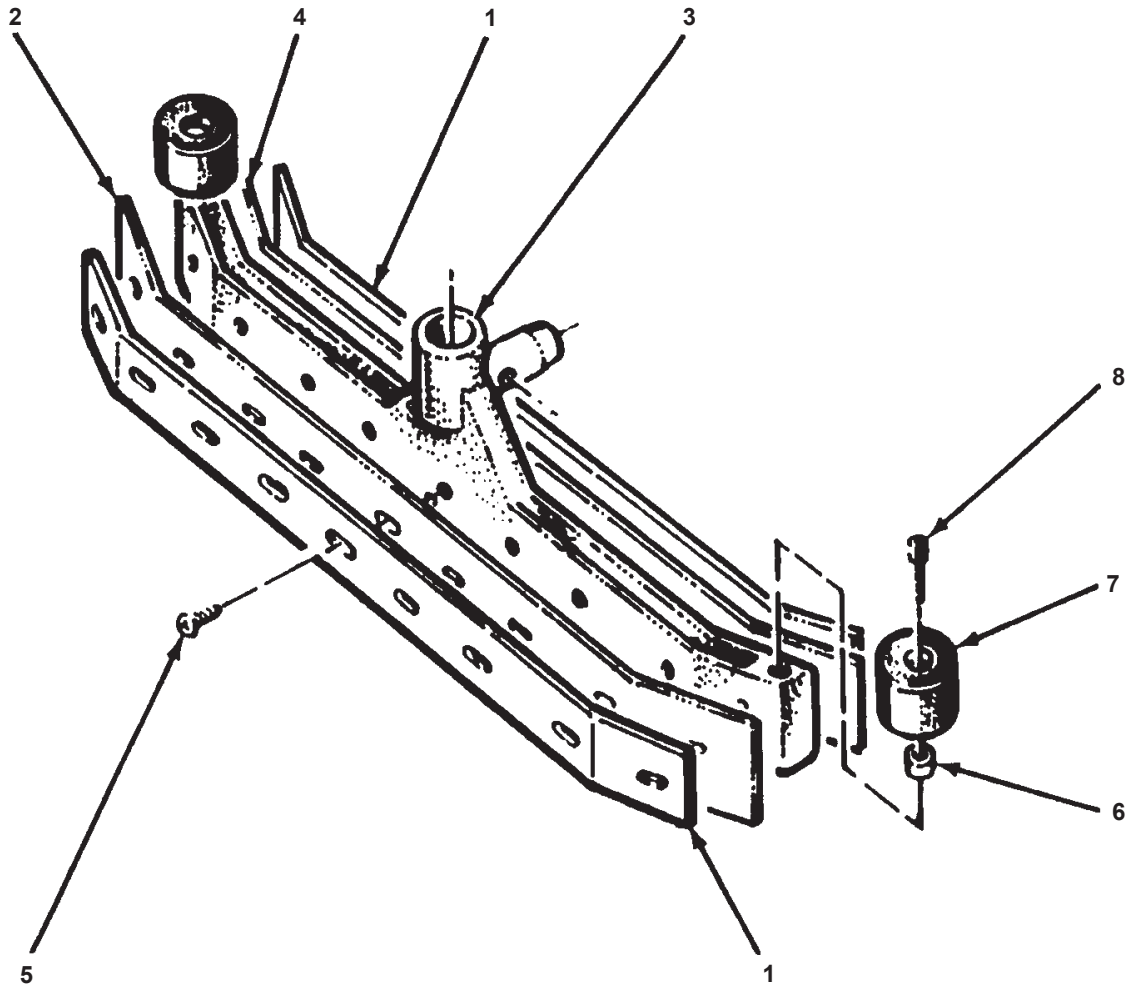

Ref	Part No.	Description	Qty
1	66921B	Retainer, Squeegee	2
2	30902A	Blade, Squeegee Rear	2
3	27703A	Squeegee, Casting	1
4	30903A	Blade, Squeegee Front	1
5	85398A	Screw 1/4 - 20 X 1/2	18
6	838201	Spacer, Wheel Guide	2
7	839702	Wheel, Brush Guide	2
8	962841	Screw, 5/16 - 18 x 1 1/4	2

Blades Available:

30918A	Blade, Sq., Front Nitrile/EPDM	1
30919A	Blade, Sq., Rear Nitrile/EPDM	1

CLARKE TECHNOLOGY
Vision 17B/BT
Solution Tank Assembly
Drawing & Parts List 6/01
Form #19169A

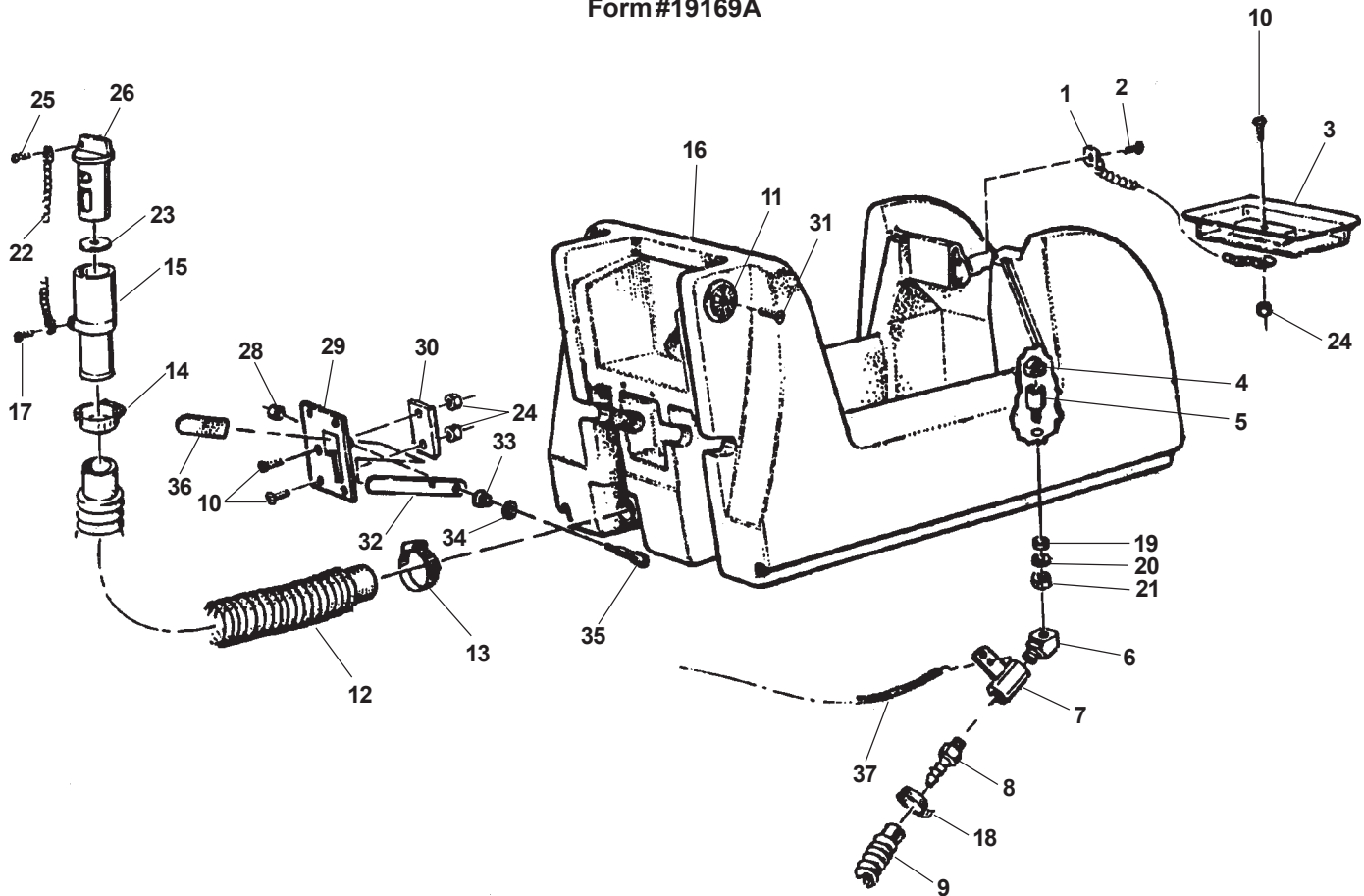

Ref	Part No.	Description	Qty
1	692409	Chain Cover	1
2	85519A	Screw 1/4 - 20 X 3/8	1
3	832322	Cover, Solution Tank	1
4	878535	Strainer, Solution Tank	1
5	60317A	Adapter, Filter	1
6	53614A	Elbow, Solution	1
7	849401	Valve, Solution	1
8	53618A	Adapter, 3/8 x 3/8	1
9	35138A	Hose, Solution	1
10	962798	Screw 10-24 X 1/2	1
11	36101A	Ratchet, Handle	2
12	30416A	Hose, Drain	1
13	752020	Clamp, Hose	1
14	832002	Clamp, Hose	1
15	839401	Drain	1
16	38964B	Tank, Solution	1
17	962943	Screw	1
18	722021	Clamp, Hose	1
19	833401	Gasket, Drain	1

Ref	Part No.	Description	Qty
20	980630	Washer	1
21	920264	Nut 3/4 - 16 Hex	1
22	52206A	Chain, Cover	1
23	833407	Gasket, Drain	1
24	81110A	Nut, 10-24	3
25	962987	Screw, 10-24 x 3/8	1
26	833901	Handle, Drain Valve	1
27	84237A	Screw, 10-32 x 1/2	2
28	81217A	Nut 1/4-20 Nylock	1
29	68762A	Plate, Squeegee Lift	1
30	68646A	Plate, Wear	1
31	84236A	Screw, 6-32	6
32	64476A	Handle, Squeegee Lift	1
33	53030A	Spring, Taper	1
34	980651	Washer	1
35	80031A	Bolt, Shoulder	1
36	52755A	Cover, Handle	1
37	52503A	Cable, Solution	1

CLARKE TECHNOLOGY
Vision 17B
Support Tank Assembly
Drawing & Parts List 11/98
Form #18909B

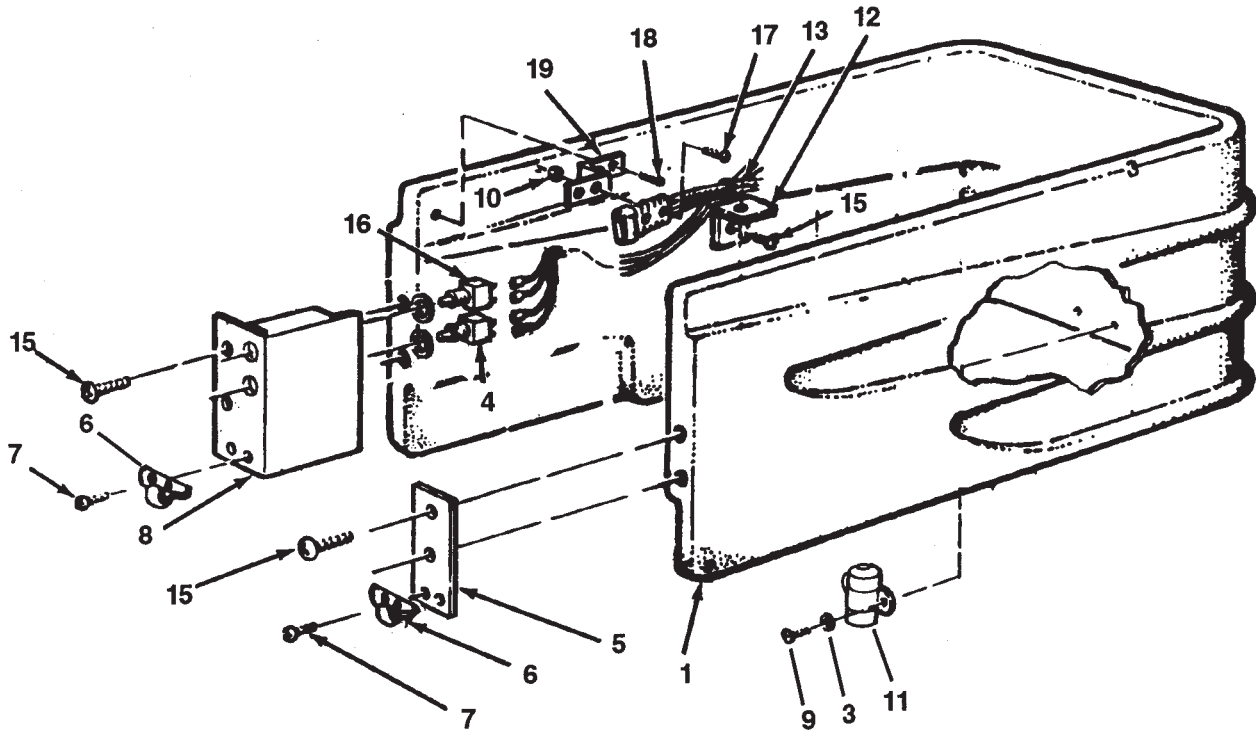

Ref	Part No.	Description	Qty
1	38952B	Support, Solution Tank	1
3	87026A	Washer, 1/4	4
4	41446A	Breaker, Circuit 30A	1
5	66689A	Plate, Clamp	1
6	608537	Strike, Clamp	2
7	85509A	Screw, 6 - 32 x 1/4	4
8	66688A	Plate, Circuit Breaker	1
9	85414A	Screw, 10-00 x 3/8	4
10	920056	Nut, 6 - 32 Elastic	2
11	878514	Solenoid, 24V	2
12	61244A	Bracket, Tank	5
13	49728A	Harness, Control	1
15	85395A	Screw, 1/4 - 20 x 1/2	9
16	41428A	Breaker, 35A	1
17	962212	Screw, 6-32 x 7/8	2
18	85387A	Screw, 1/4 - 20 x 3/4	1
19	61246A	Bracket, Battery Plug	1
NI	77050A	Label, Brush Lift	1

CLARKE TECHNOLOGY
Vision 17BT
Support Tank Assembly
Drawing & Parts List 11/98
Form #18915B

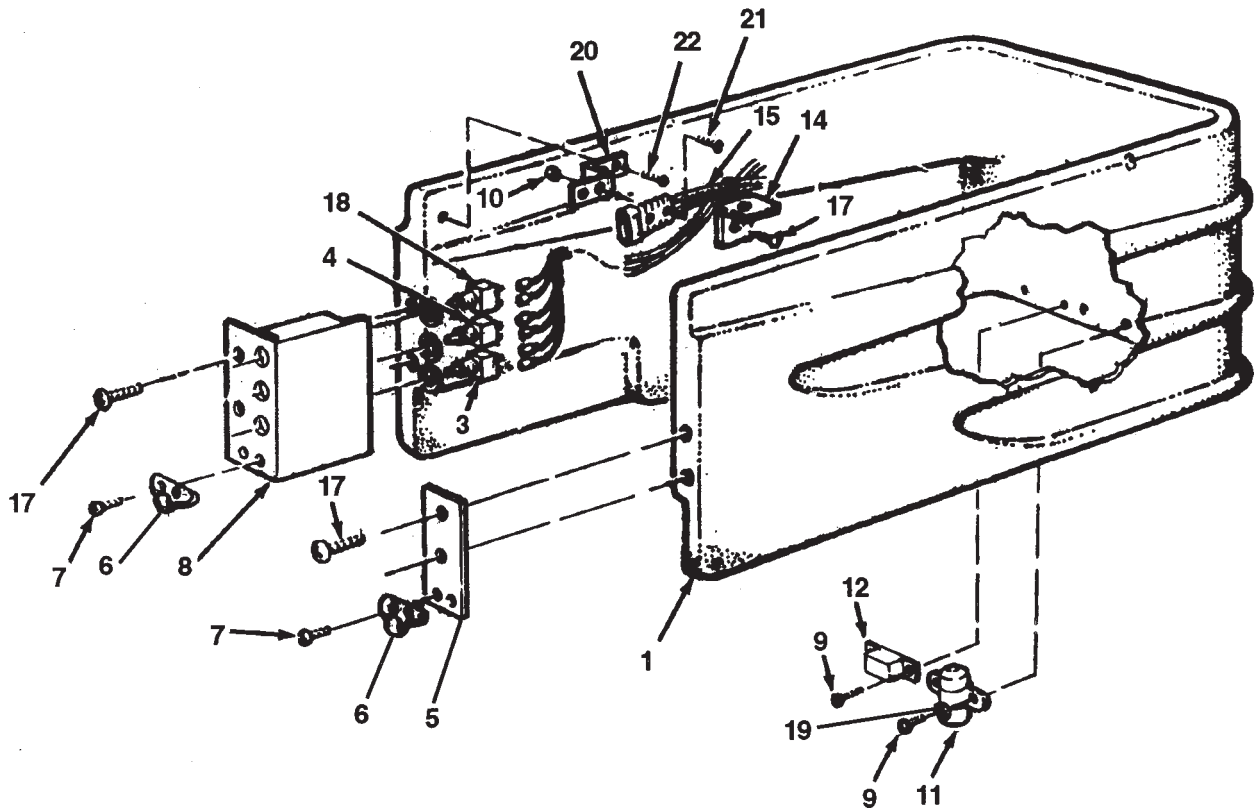

Ref	Part No.	Description	Qty
1	38952B	Support, Solution Tank	1
3	41438A	Breaker, Circuit 7A	1
4	41446A	Breaker, Circuit 30A	1
5	66689A	Plate, Clamp	1
6	608537	Strike, Clamp	2
7	85509A	Screw, 6 - 32 x 1/4	4
8	66688A	Plate, Circuit Breaker	1
9	85414A	Screw, 10-00 x 3/8	8
10	920056	Nut, 6 - 32 Elastic	2
11	878514	Solenoid, 24V	3
12	46312A	Relay, Time	1
14	61244A	Bracket, Tank	5
15	49730A	Harness, Control	1
17	85395A	Screw, 1/4 - 20 x 1/2	9
18	41428A	Breaker, 35A	1
19	87026A	Washer 1/4	6
20	61246A	Bracket, Battery Plug	1
21	962212	Screw, 6-32 x 7/8	2
22	85387A	Screw, 1/4 - 20 x 3/4	1
NI	77050A	Label, Brush Lift	1

CLARKE TECHNOLOGY
 Vision 17BT
 Brake Kit #10773A
 Drawing & Parts List 5/98

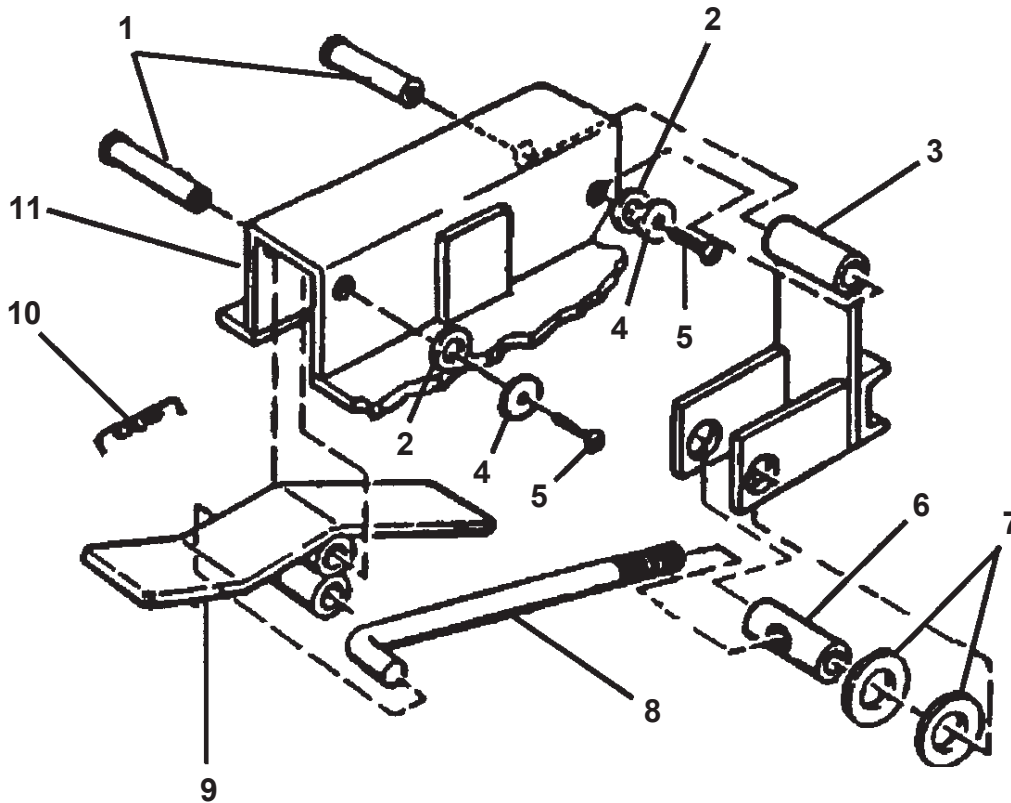

Ref #	Part No.	Description	Qty
1	66536A	Pin, Brake	2
2	87027A	Washer	2
3	17519A	Brake, Pad Weldment	1
4	87036A	Washer, #10 S.S.	2
5	85397A	Screw, 10-24 x 3/8 S.S.	2
6	67422A	Shaft, Brake	1
7	87613A	Washer, Nylon	2
8	67133A	Rod, Brake	1
9	10735A	Pedal, Brake	1
10	608340	Spring, Brake	1
11	Ref.	Machine Frame	ref.

CLARKETECHNOLOGY
Vision 17B/BT
Vacuum Motor
Drawing & Parts List 11/93
Form #44917A

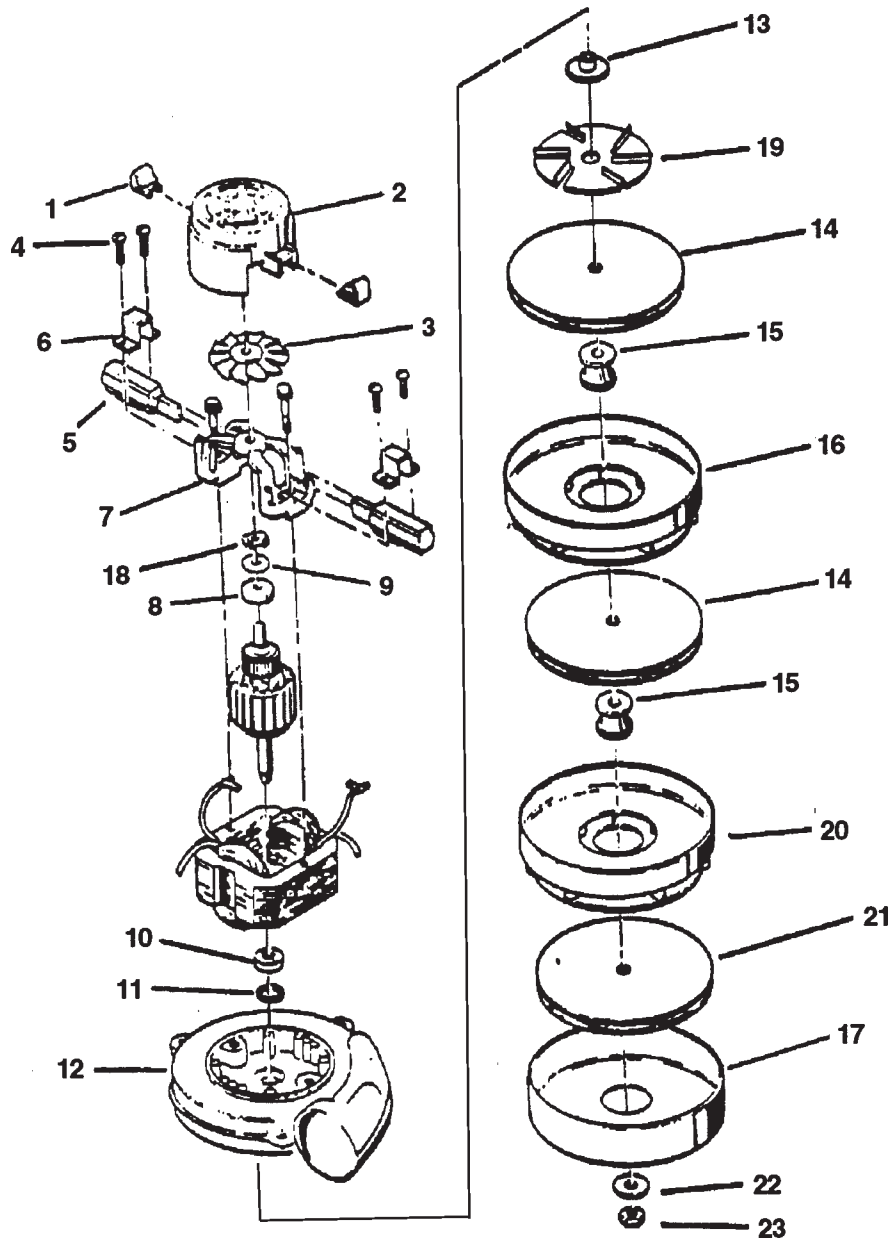

Ref #	Part No.	Description	Qty
1	51913A	Clip (Optional)	2
2	54809A	Housing - Vent	1
*3		Fan	1
4	85303A	Screw, 8 x 32 - 3/8 PN	4
5	40817A	Brush Mechanism	2
6	51914A	Clamp	2
7	50618A	Bracket, Commutator End	1
*8		Bearing	1
9	672714	Disc	1
*10		Bearing	1
11	59803A	Washer, Neoprene	1
*12		Bracket, Fan End	1
13	58500A	Spacer	1

Ref #	Part No.	Description	Qty
14	53914A	Fan, Rotating	2
15	658201	Spacer	2
*16		Fan, Stationary	1
*17		Shell, Fan	1
18	638313	Spring, Load	1
*19		Fan, Air Seal	1
*20		Fan, Stationary	1
*21		Fan, Rotating	1
*22		Washer	1
*23		Nut	1

*NOTE: #'s 3, 8, 10, 12, 16, 17, 19, 20, 21, 22 & 23 are not available at this time.

CLARKE TECHNOLOGY
Vision 17B/BT
Gear Box #54238A
Drawing & Parts List 6/94

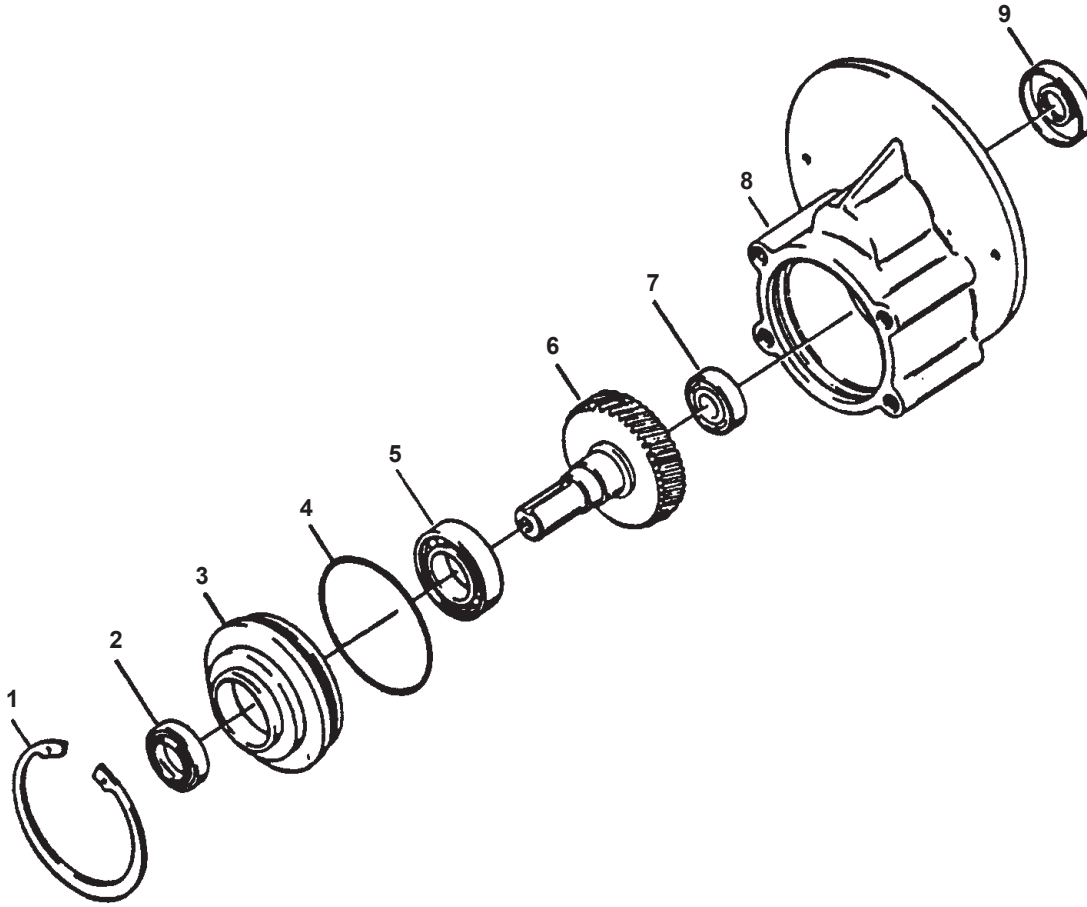

Ref	Part No.	Description	Qty
1	57846A	Ring, Snap	1
2	58143A	Seal, Oil, Small	1
3	52050A	Cap End	1
4	56668A	O - Ring	1
5	51176A	Bearing, Large	1
6	58316A	Shaft and Gear	1
7	902605	Bearing, Small	1
8	54883A	Housing	1
9	58144A	Seal, Oil Large	1
NI		Grease	1oz

CLARKE TECHNOLOGY
Vision 17B/BT
Drawing & Parts List 3/95
Form#10503A

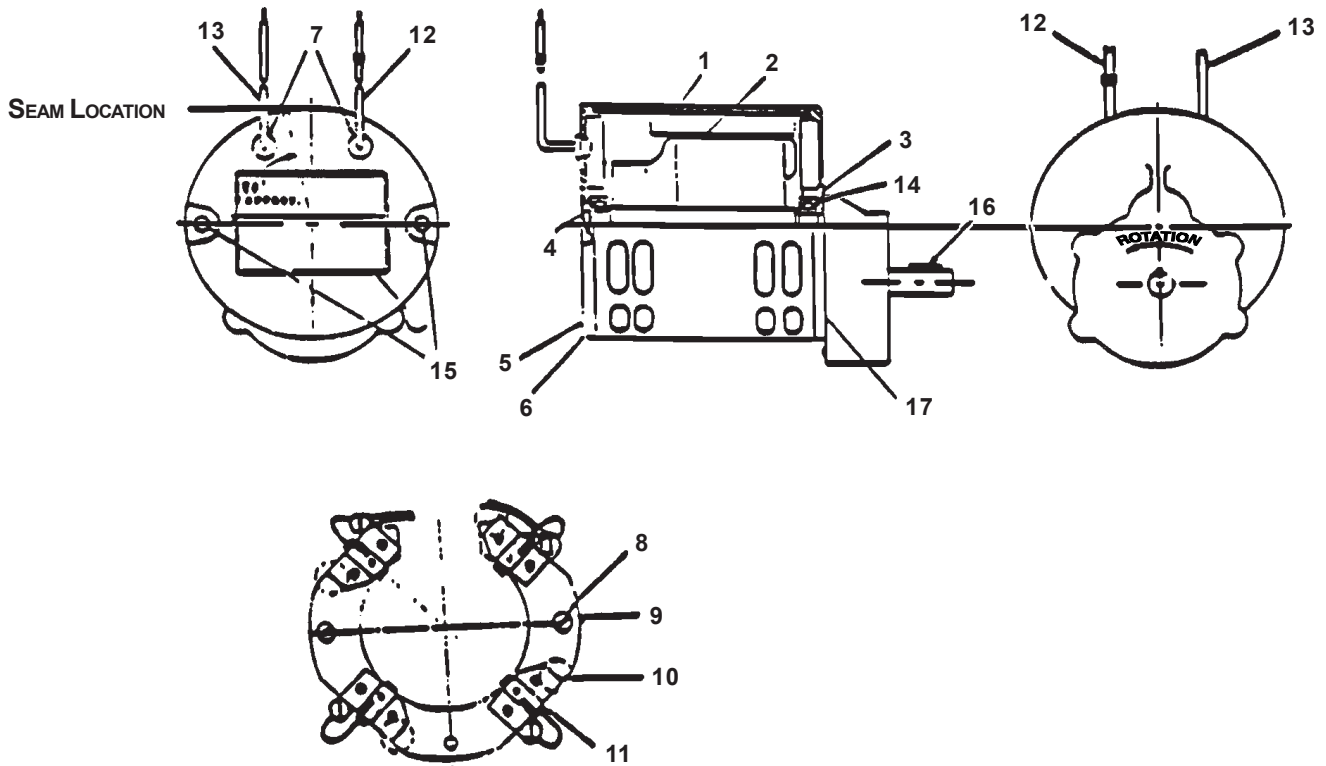

Item	Part No.	Description	Qty
1	56478A	Stator Frame Assembly (w/Magnets & Clips)	1
2	50142A	Armature Assembly (w. B.E. & F.E. Bearings)	1
3	902654	Bearings B.E.	1
4	902550	Bearing F.E.	1
5	51840A	Commutator Bracket Assembly (w/Brush BRD Assembly Leads)	1
6	50520A	Commutator Bracket	1
7	56480A	Strain Relief	2
8	962546	Brush Board Screw	2
9	50517A	Brush Board Assembly (w/ Springs & Brushes)	1
10	448396	Brush Spring	4
11	40826A	Brush Assembly	4
12	55657A	Lead Assembly	1
13	55656A	Lead Assembly	1
14	59805A	Helical Washer	1
15	50515A	Thru Bolt	2
16	44809A	Shaft Key	1
17	54238A	B.E. Bracket Assembly (Gear Box)	1

CLARKETECHNOLOGY
Vision 17BT
Traverse Motor Drawing & Parts List 2/96
Motor #45031A

View from plain end schematic

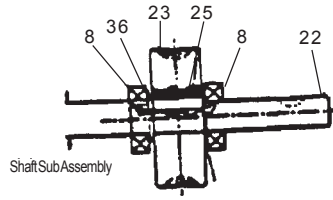
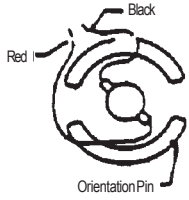

Shaft Sub Assembly Instructions

1. Assemble the retaining ring (24) to the output shaft (22) centering the middle tab of the "E" ring in the keyway. The center tab should bottom in the keyway.
2. Assemble the key (25) to the output shaft (22) butting the key against the center tab of the retaining ring (24). Dimensions over the key and shaft is .381.
3. Assemble gear (23). The gear should be started by hand over the shaft and key to assure proper alignment and butt against the retaining ring (24).
4. Assemble spacer (36).
5. Assemble the bearing (8) onto the shaft with the seal to the inside. Press only on the inner race until the bearings are butted securely against the gear spacer on one side and against the "E" ring on the other side.

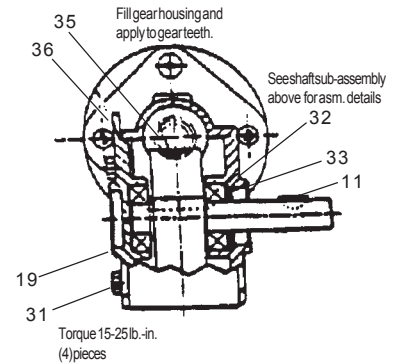
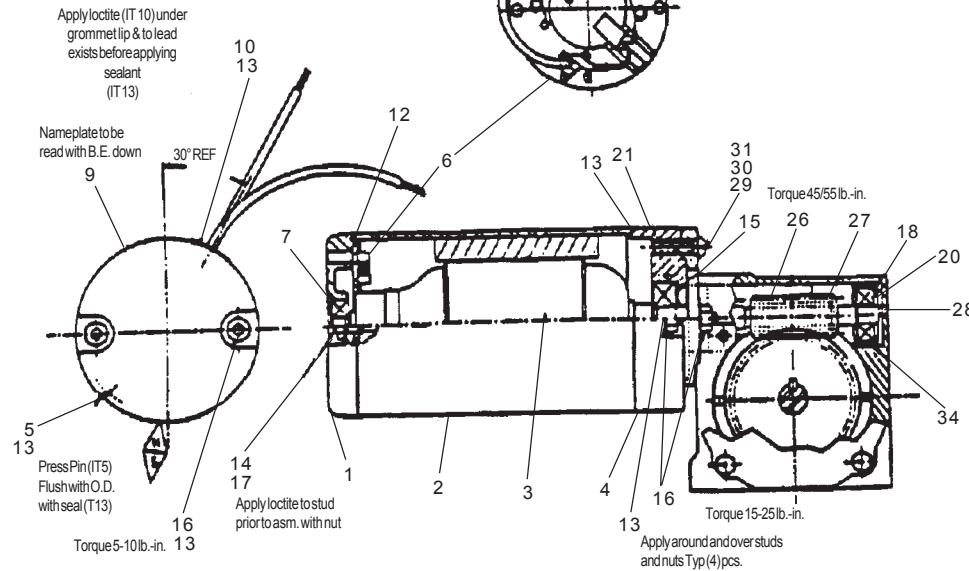
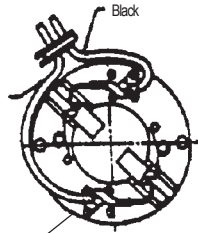

Ref	Part No.	Description	Qty
1	*	Housing Brush End	1
2	*	Field Assembly	1
3	50147A	Armature Assembly	1
4	*	Housing, Plain End	1
5	*	Roll Pin	1
6	51861A	Lead/BR Card Assembly	1
7	902679	Ball Bearing	1
8	51181A	Ball Bearing	2
9	*	Printed Mylar Stock	1
10	*	Loctite 404	1
11	55412A	#404 Woodruff Key	1
12	56671A	O Ring	1
13	*	Sealant	1
14	*	Stud, 10-32 X 6.45	2
15	53319A	Load Spring	1
16	*	Nut, Keps 10-32	6
17	*	Loctite 404	1
18	*	Gear Housing	1

Ref	Part No.	Description	Qty
19	*	Gear Cap	1
20	51180A	Ball Bearing	1
21	51179A	Ball Bearing	1
22	58318A	Output Shaft	1
23	54414A	Worm Gear	1
24	*	Retaining Ring	1
25	*	Key 1/8 x 1/8	1
26	59869A	Worm	1
27	925597	Roll Pin	1
28	*	Retaining Ring	1
29	962892	Screw, 1/4 - 20	1
30	980614	Lock Washer 1/4"	1
31	*	Screw, 10-32 SEMS	4
32	58694A	Load Spring	1
33	59868A	Washer	1
34	57850A	Ring, Bearing Mounting	1
35	*	Grease, Nyooel 15#	1
36	*	Spacer	1

*Illustrated for assembly reference only.

CLARKE TECHNOLOGY
Vision 17BT
Traverse Motor 24V
Drawing & Parts List 2/96
Form #45031C

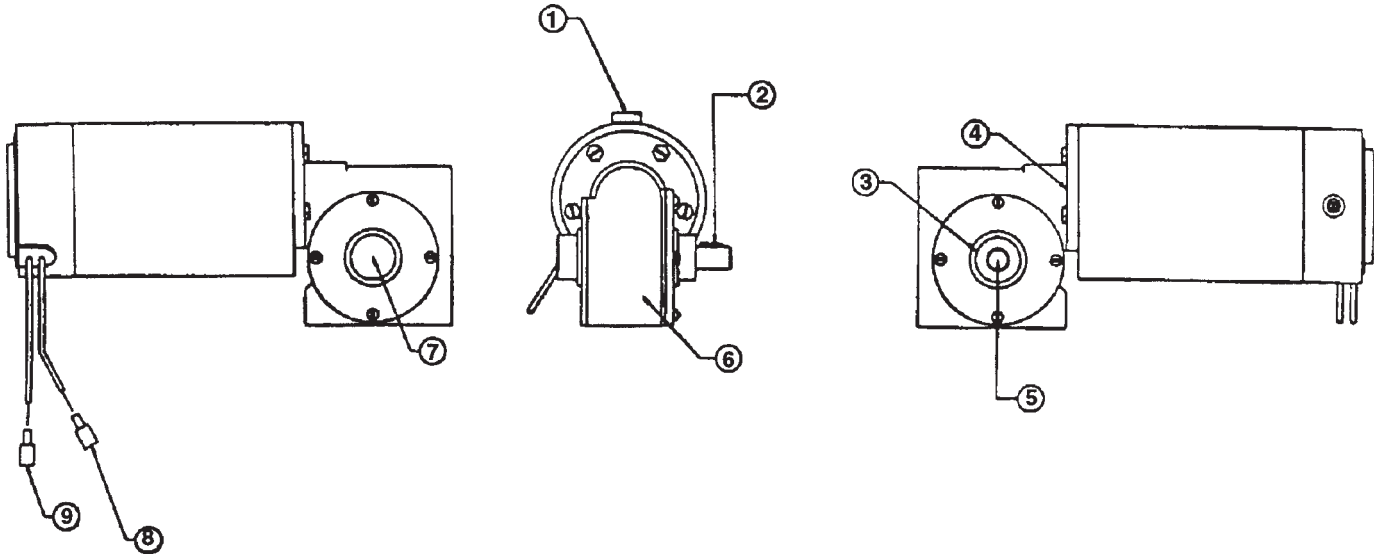

Ref	Part No.	Description	Qty
1	40831A	Carbon, Brush	2
2	55412A	Key	1
3	58152A	Shaft, Seal	1
4	54370A	Gasket, O'Ring	1
5	54416A	Gear Assembly	1
6	N/A	Gear Housing	N/A
7	52060A	Cap, Gear Head	1
8	47905A	Terminal, 1/4 FIFQD	1
9	47905A	Terminal, 1/4 FIFQD	1
10	NI	1.9 oz. Mobilith SCH 1500 Oil	

CLARKE TECHNOLOGY
Vision 17B/BT
Battery Charger Drawing & Parts List 11/93

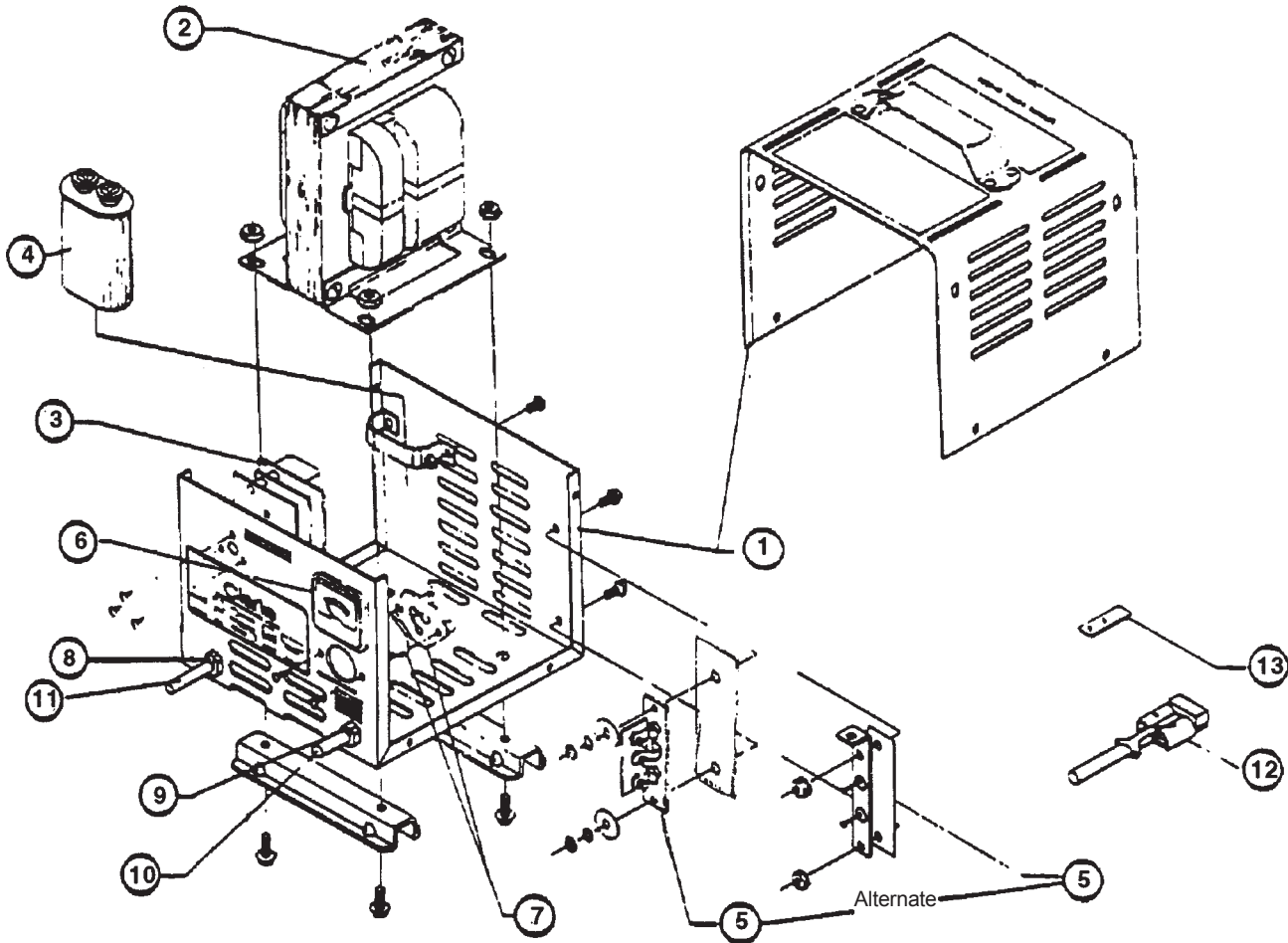

⚠ WARNING: All electrical repairs must be performed by qualified personnel only.

Charger #40510A: 24 Volt, 10 Amp D.C., 115 Volt A.C., 60 Hz

Charger #40511A: 24 Volt, 10 Amp D.C., 230 Volt A.C., 50 Hz

Ref	Description	Charger 40510A	Charger 40511A
1	Charger Case	41130A	41131A
2	Transformer	799225	799226
3	Electronic Controller Kit	47500A	48200A
4	Capacitor 660 V.A.C.	915511	915511
5	Heat Sink Assembly	43300A	43300A
6	Ammeter	40206A	40206A
7	Fuse Holder (2) Cartridge Fuse (2)	283360 912216	283360 912216
8	Strain Relief, A.C. Cord	837525	837525
9	Strain Relief, D.C. Cord	837525	837525
10	D.C. Cord Assembly	908981	908981
11	A.C. Cord Assembly	908982	908983
12	Housing	911470	911470
13	D.C. Plug Lock Key	795020	795020

CLARKE TECHNOLOGY
Vision 17B
Model #00380A - 24 V Electrical Schematic 8/98

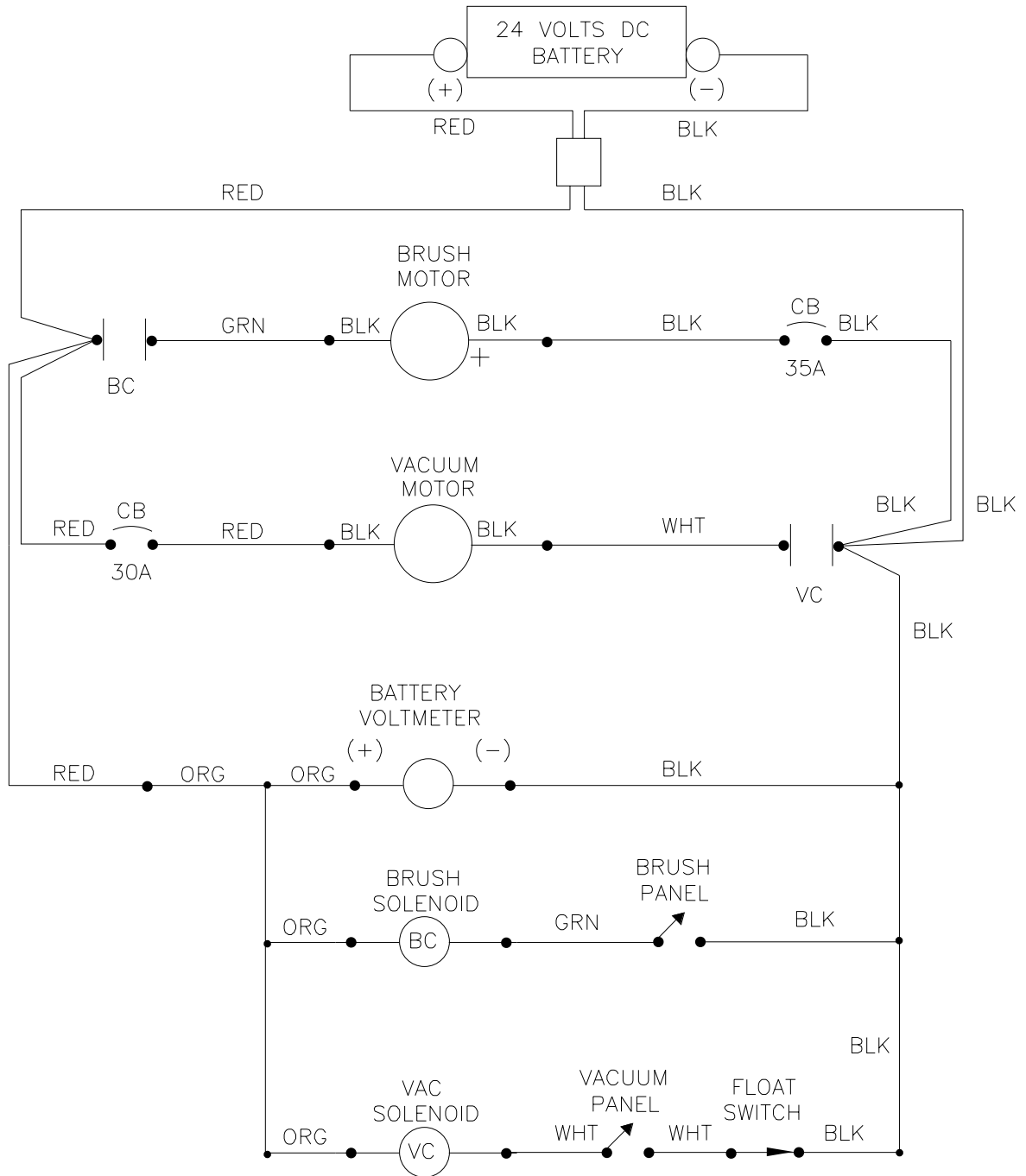

CLARKE TECHNOLOGY
Vision 17BT
Model #00390A - 24 V Electrical Schematic 4/03

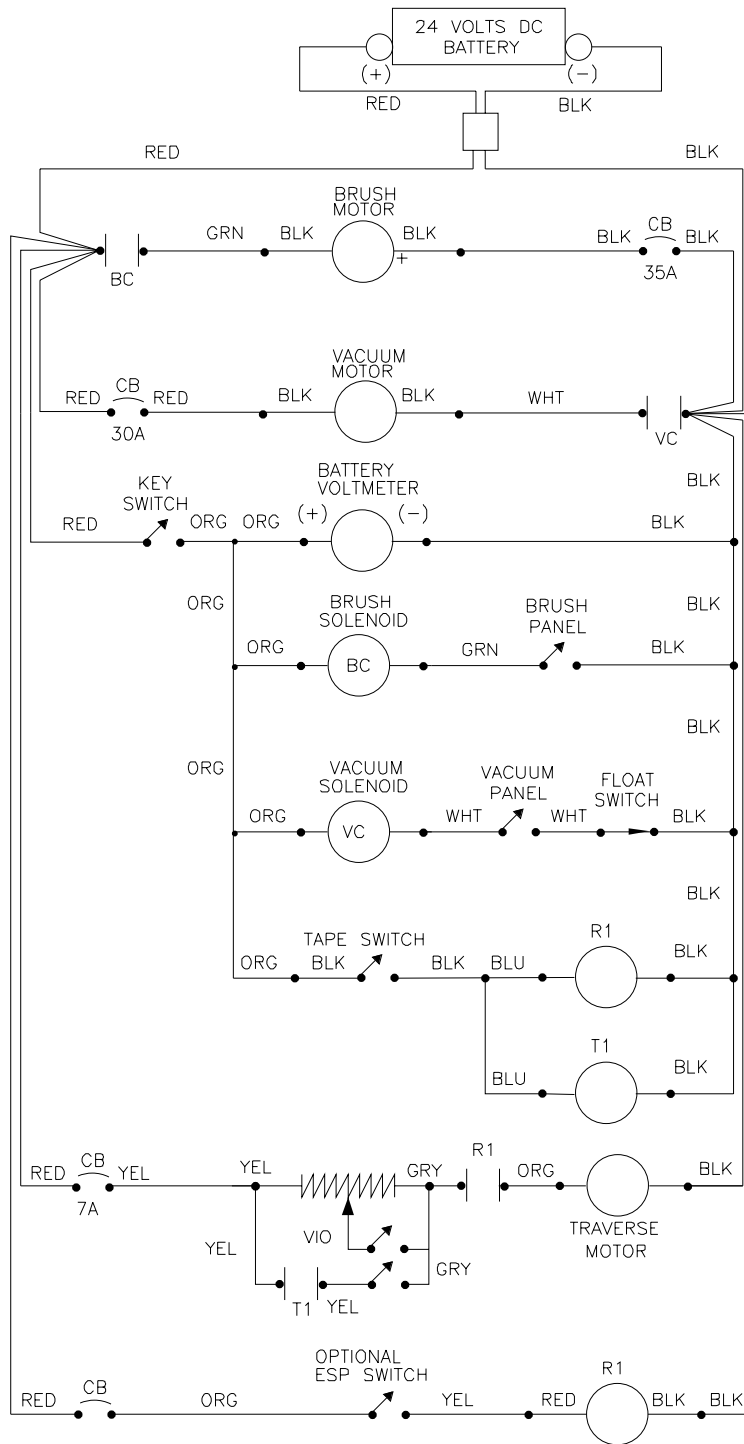

3. R1 = TRAVERSE SOLENOID.
R1 SUPPLIES POWER TO TRAVERSE MOTOR WHEN TOUCH SWITCH IS ACTIVATED.
2. T1 = TRAVERSE HIGH DELAY TIMER.
T1 DELAYS HIGH SPEED FOR 1 TO 2 SECONDS AFTER TOUCH SWITCH IS ACTIVATED.
1. * = NOT CONNECTED

CLARKE TECHNOLOGY Vision 17B 24V Connection Diagram 6/01

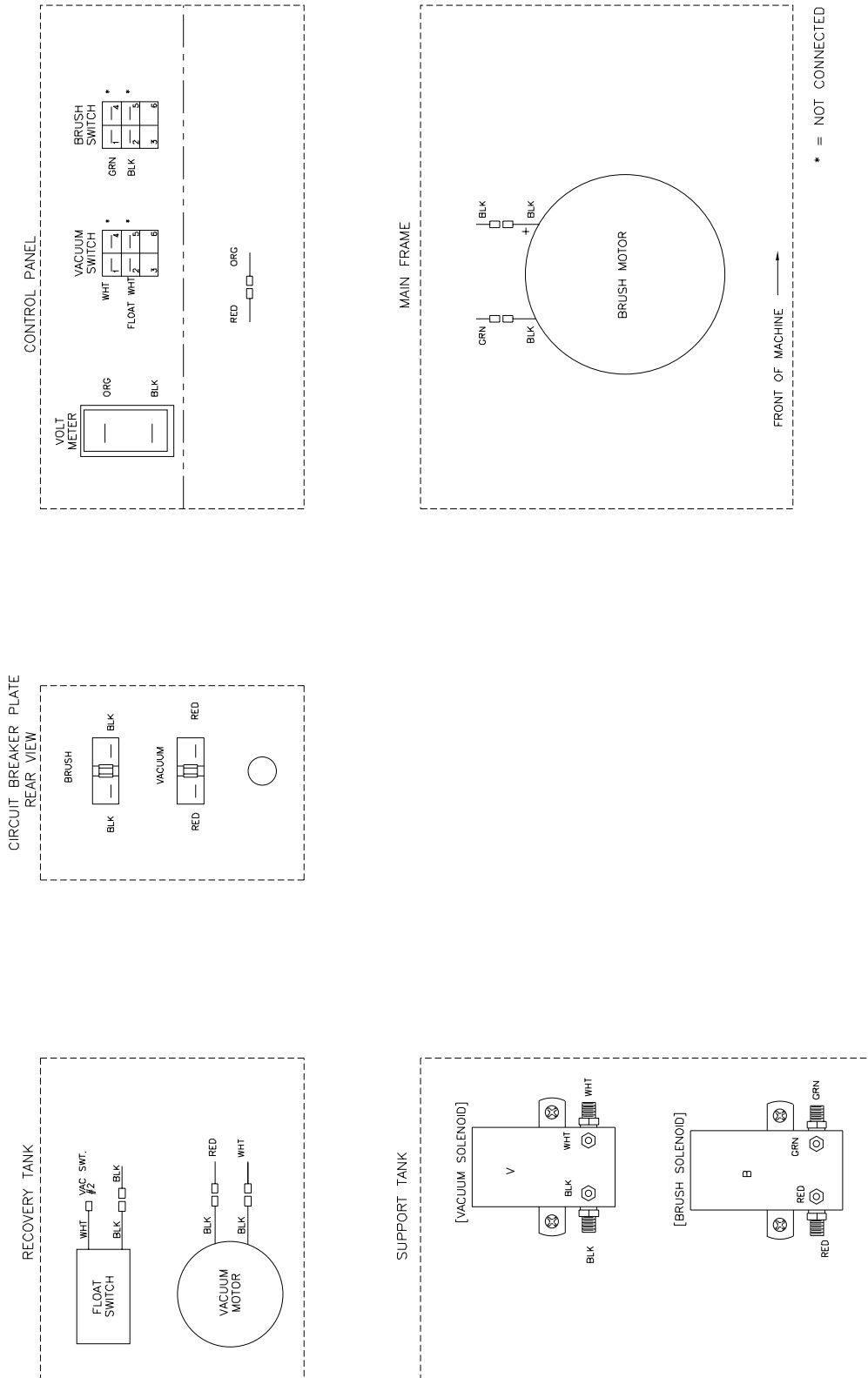

CLARKE TECHNOLOGY Vision 17BT 24V Connection Diagram 6/01

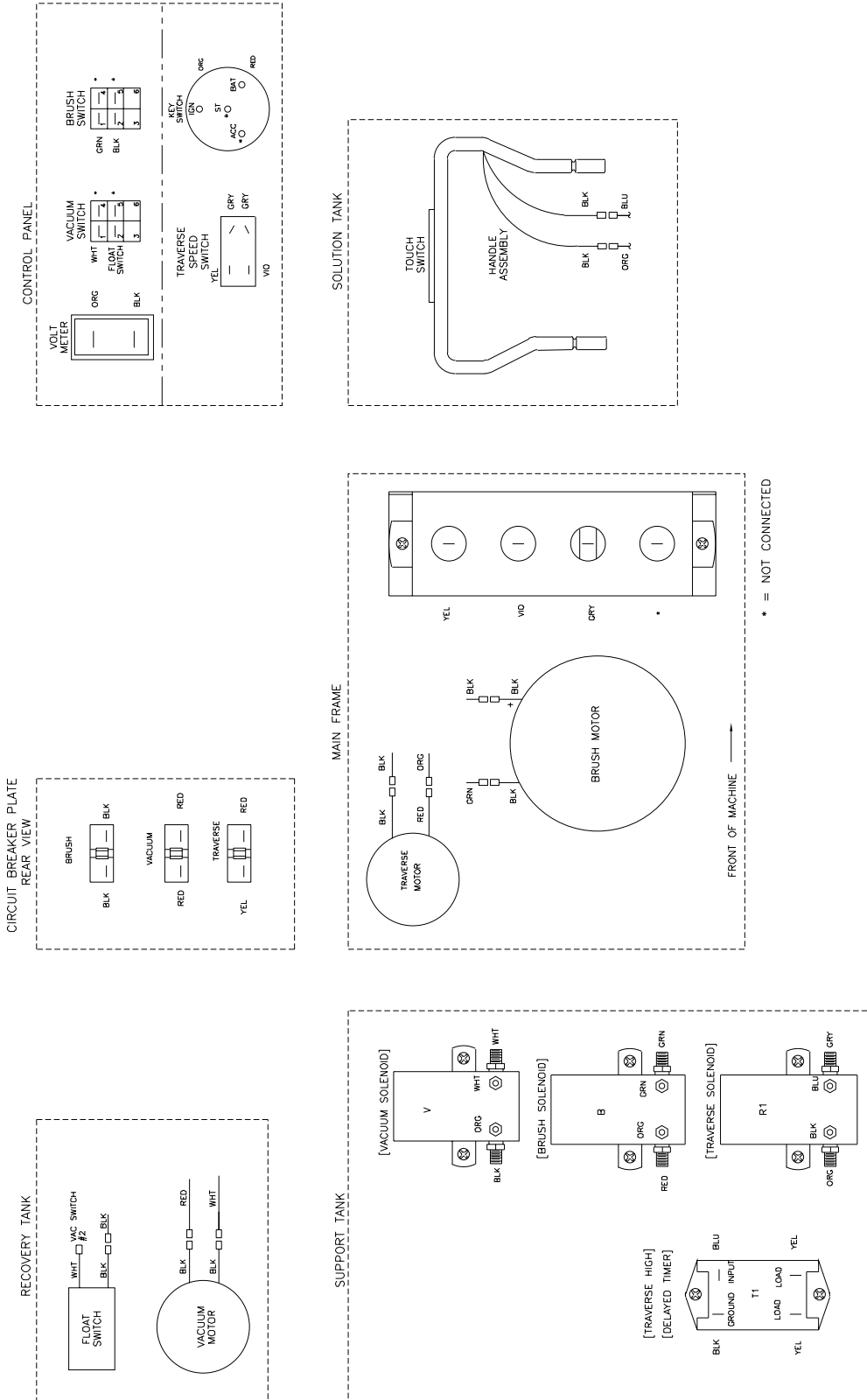

ALTO® PRODUCT SUPPORT BRANCHES

U. S. A. Locations

HEAD OFFICE

ALTO U.S. Inc., St. Louis, Missouri
16253 Swingley Ridge Road, Suite 200
Chesterfield, Missouri 63017-1725

PRODUCTION FACILITIES

ALTO U.S. Inc., Springdale, Arkansas
2100 Highway 265
Springdale, Arkansas 72764
(479) 750-1000
Customer Service - 1-800-253-0367
Technical Service - 1-800-356-7274

ALTO U.S. Inc., Bowling Green, Ohio 43402
1100 Haskins Road

SERVICE FACILITIES

ALTO U.S. Inc., Carlstadt, New Jersey 07072
150 Commerce Road
(201) 460-4774

ALTO U.S. Inc., Elk Grove, Illinois 60007
2280 Elmhurst Road
(847) 956-7900

ALTO U.S. Inc., Denver, Colorado 80204
1955 West 13th Ave.
(303) 623-4367

ALTO U.S. Inc., Houston, Texas 77040
7215 North Gessner Road

SALES AND SERVICE FACILITIES

ALTO U.S. Inc., Madison Heights, Michigan 48071-0158
29815 John R.
(810) 544-6300

ALTO U.S. Inc., Marietta, Georgia 30062
1355 West Oak Common Lane
(770) 973-5225

CLARKE TECHNOLOGY
AMERICAN SANDERS TECHNOLOGY
A.L. COOK TECHNOLOGY
SIMPSON TECHNOLOGY
DELCO TECHNOLOGY
Customer Service Headquarters and
Factory
2100 Highway 265
Springdale, Arkansas 72764
(479) 750-1000
Technical Service
1-800-356-7274

European Locations

PRODUCTION FACILITIES

ALTO Danmark A/S, Aalborg
Blytaekkervej 2
DK-9000 Aalborg
+45 72 18 21 00

ALTO Danmark A/S, Hadsund
Industrikvarteret
DK-9560 Hadsund
+45 72 18 21 00

SALES SUBSIDIARIES

ALTO Canada Ltd., Rexdale Ontario
24 Constellation Ct.
(416) 675-5830

ALTO Overseas Inc., Sydney (Australia)
1B/8 Resolution Drive
Caringbah NSW 2229
+61 2 9524 6122

ALTO Cleaning Systems Asia Pte Ltd., Singapore
No. 17 Link Road
Singapore 619034
+65 268 1006

ALTO Deutschland GmbH, Bellenberg (Germany)
Guido-Oberdorfer-Straße 2-8
89287 Bellenberg
+49 0180 5 37 37 37

ALTO Cleaning Systems (UK) Ltd., Penrith
Gilwilly Industrial Estate
Penrith
Cumbria CA11 9BN
+44 1768 868 995

ALTO France S.A. Strasbourg
B.P. 44, 4 Place d'Ostwald
F-67036 Strasbourg
Cedex 2
+33 3 8828 8400

ALTO Nederland B.V. Vianen
Stuartweg 4C
NL-4131 NJ Vianen
+31 347 324000

ALTO Sverige AB, Molndal (Sweden)
Aminogatan 18
Box 4029
S-431 04 Molndal
+46 31 706 73 00

ALTO Norge A/S, Oslo (Norway)
Bjornerudveien 24
N-1266
+47 2275 1770

CLARKE TECHNOLOGY U.S. LIMITED WARRANTY

This Clarke Technology Industrial/Commercial Product is warranted to be free from defects in materials and workmanship under normal use and service for a period of one year from the date of purchase, when operated and maintained in accordance with Clarke Technology's Maintenance and Operations instructions.

This brush drive and traverse motors are warranted to be free from defects in materials and workmanship under normal use and service for one year from the date of purchase, provided the motors are inspected for carbon motor brush wear at six-month intervals by an authorized Clarke Technology repair station. Failure to comply with the six-month inspection requirement or failure to replace worn motor brushes identified during the inspection will void the one-year warranty on the motors. Cost of the six-month inspection and replacement of carbon motor brushes is the responsibility of the purchaser. In the event of a warranty claim on the motors, proof of inspection and any required motor brush replacement must be provided.

This warranty is extended only to the original purchaser for use of the product. It does not cover normal wear parts such as electrical cable, rubber parts, and motor brushes.

Clarke Technology's liability under this warranty is limited to repair of the product and/or replacement of parts and is given to purchaser in lieu of all other remedies, including INCIDENTAL AND CONSEQUENTIAL DAMAGES.

THERE ARE NO EXPRESS WARRANTIES OTHER THAN THOSE SPECIFIED HEREIN. THERE ARE NO WARRANTIES WHICH EXTEND BEYOND THE DESCRIPTION OF THE FACE HEREOF. NO WARRANTIES, INCLUDING BUT NOT LIMITED TO WARRANTY OF MERCHANTABILITY, SHALL BE IMPLIED. A warranty registration card is provided with your Clarke Technology product. Return the card to assist Clarke Technology in providing the performance you expect from your new floor machine.

If a difficulty develops with the product, you should: a) Contact the nearest authorized Clarke Technology repair location or contact the Clarke Technology Service Operations Department, 2100 Highway 265, Springdale, Arkansas 72764, for the nearest authorized Clarke Technology repair location. Only these locations are authorized to make repairs to the product under this warranty. (b) Return the product to the nearest Clarke Technology repair location. Transportation charges to and from the repair location must be prepaid by the purchaser. Clarke Technology will repair the product and/or replace any defective parts without charge within a reasonable time after receipt of the product.

ALTO U.S. Inc., 2100 Highway 265, Springdale, Arkansas 72764.

BATTERY WARRANTY

In addition to the items above (except as to the one-year period), any original equipment Clarke Technology Battery which becomes unserviceable under normal use within a period of ninety (90) days from date of sale to the original user will be repaired or replaced with one of equal specification at our option, F.O.B. any authorized Clarke Technology Sales or Service Branch, with no charge to the user, except transportation costs. After expiration of the above ninety (90) day period, any battery which fails under normal use will be adjusted to the original user with a new battery of equal specification on an eighteen (18) months pro rate basis from the date of purchase. Adjustment will be determined using the then current list price, plus transportation costs.

Warranty is rendered null and void if battery is not kept filled to the proper level with DISTILLED WATER.

CLARKE TECHNOLOGY: POLYDUR® AUTOMATIC SCRUBBER SOLUTION AND RECOVERY TANK FIVE-YEAR GUARANTEE

Your new Clarke Technology Vision Automatic Scrubber has polydur Solution and Recovery Tanks. Polydur is a rotationally molded, medium-density linear polyethylene that won't crack or dent, and withstands most corrosives and temperature extremes. Clarke Technology backs up your Polydur tanks with a five-year guarantee. If a tank breaks or leaks under normal use within five years of the date of purchase, it will be replaced free.

CLARKE TECHNOLOGY UNIBODY FRAME THREE-YEAR WARRANTY

Clarke Technology warranties the frame for the new Vision automatic Scrubbers for a period of three years against defects in materials and workmanship under normal use and service.

**CLARKE TECHNOLOGY reserves the right to make changes or improvements to its machine
without notice.**

Always use genuine Clarke Technology Parts for repair.



**CLARKE TECHNOLOGY
2100 Highway 265
Springdale, Arkansas, 72764**