



Electronic Service Manuals

This electronic document is provided as a service to our customers. We do not create the contents of the information contained in this document. Should you have detailed questions pertaining to the information contained in this document, you may contact Michco, or the manufacturer which provided the original information in this electronic deliverable. Michco's only part in this electronic deliverable was the electronic assembly process. By providing this manual on line we are not guaranteeing parts availability.

You may contact Michco through the following methods:

Phone (517) 484-9312 or (800) 331-3339

2011 N. High St. -- Lansing, Michigan -- 48906

Fax: (517) 484-9836

Email: CustServe@Michco.com

Web site: www.Michco.Com

Parts Web site: www.FloorMachineParts.Com

Order Parts on Line at:

www.FloorMachineParts.Com

Directly to Parts & Service:

By Email: **Shop@Michco.com**

By Fax: (517) 702-2041

By Voice: Use numbers above.

Serving the Cleaning Industry Since 1922

Notice: All copyrighted material remains property of original owners, all trademarks are property of respective owners. Manuals are subject to Manufacturer's reproduction limitations. Originals or reproductions were provided by manufacturers through a request. We make no warranty as to the correctness of information provided in this document and you assume all risk. By placing these manuals on line we are not declaring our corporation to be an manufacturer authorized dealer or provider, please check our web site for authorized manufacturers we represent.

Clarke®

**Operator's
Manual**

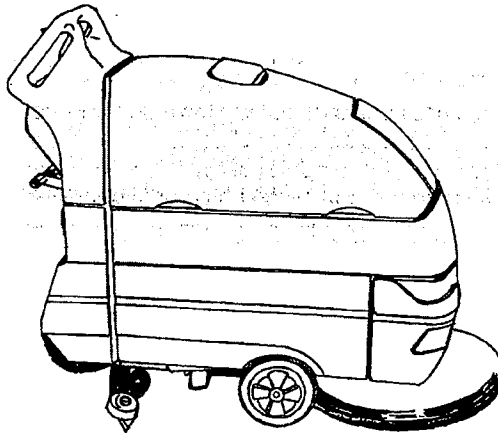

**ENCORE
S20/L20**

U.S. Patent No. 5,383,251; No. 6,105,192; No. 6,557,207; & Patent Pending

READ THIS BOOK

This book has important information for the use and safe operation of this machine. Failure to read this book prior to operating or attempting any service or maintenance procedure to your Clarke machine could result in injury to you or to other personnel; damage to the machine or to other property could occur as well. You must have training in the operation of this machine before using it. If operator(s) cannot read English, have this manual explained fully before attempting to operate this machine.

Si Ud. o sus operadores no pueden leer el Inglés, se hagan explicar este manual completamente antes de tratar el manejo o servicio de esta máquina.

All directions given in this book are as seen from the operator's position at the rear of the machine.

For new books write to: Clarke®, 2100 Highway 265, Springdale, Arkansas 72764.

Table of Contents



Operator Safety Instructions	3
Introduction & Machine Specifications	5
Procedures for Transporting Machine	6
Machine Control Panel	8
Machine Controls and Features	9
How to Prepare the Machine for Operation	10
How to Install the Batteries	11
Battery Maintenance	11
How to Charge the Batteries	12
How to Install or Remove a Brush or Pad Driver	13
How to Operate the Machine	14
How to Operate the Squeegee	14
Filling the Solution Tank	14
Operating the Machine	15
Adjusting the Brush Pressure	15
How to Clean a Dirty Floor	16
SECTION II - Parts and Service Manual	
How to Correct Problems in the Machine	18
Maintenance	20
Procedures Before Work is Began	20
Procedures to Perform at the End of Work	21
Procedures to Perform Every Week	22
Maintenance for the Squeegee	23
How to Adjust the Squeegee	23
How to Clean the Solution Line	24
Machine Variables and Accessories	25
Accessories	27
Encore L20/S20 Final Assembly Drawing	28
Parts List	29
Encore L20/S20 Recovery Drawing	30
Parts List	31
Solution Tank Assembly Drawing	32
Parts List	33
Squeegee Lift Assembly: Drawing and Parts List	34
Squeegee Assembly Drawing and Parts List	35
Squeegee Assembly Drawing and Parts List	36
Encore L20 Frame Transaxle Assembly: Drawing and Parts List	37
Encore S20 Frame Assembly Drawing and Parts List	38
Brush Lift Assembly Drawing and Parts List	39
Brush Housing Assembly Drawing and Parts List	40
Transaxle Repair Parts	41
Transaxle Drawing and Parts List	42
Brush Motor Assembly Drawing and Parts List	43
Gearbox Assembly Drawing and Parts List	44
Vacuum Motor Drawing and Parts List	45
Battery Charger Drawing and Parts List	46
Optional Brake Assembly Drawing and Parts List	47
Kits:	
Electronic Solution Valve Kit without Solution Shut-Off Drawing & Parts List	48
Electronic Solution Valve Kit with Solution Shut-Off Drawing & Parts List	49
ESP Recycle System Kit	50
Powerwand System Drawing & Parts List	51
Brush Meter Kit Parts List	52
Hour Meter Kit Parts List	52
Low Voltage Cut-Off Kit	53
For Machines with a 41150B Traverse Controller:	
Rear Panel Assembly Drawing	56
Parts List	57
Electrical Cover Assembly Drawing and Parts List	58
Encore L20 Electrical Schematic	59
Encore L20 Connection Diagram	60
Encore S20 Electrical Schematic	61
Encore S20 Connection Diagram	62
For Machines with a 41150C Traverse Controller:	
Rear Panel Assembly Drawing	64
Parts List	65
Electrical Cover Assembly Drawing and Parts List	66
Encore L20 Electrical Schematic	67
Encore L20 Connection Diagram	68









OPERATOR SAFETY INSTRUCTIONS









 **WARNING**

 **AVERTISSEMENT**

 **ADVERTENCIA**

-  **DANGER:** Failure to read and observe all **DANGER** statements could result in severe bodily injury or death. Read and observe all **DANGER** statements found in your Owner's Manual and on your machine.
-  **WARNING:** Failure to read and observe all **WARNING** statements could result in injury to you or to other personnel; property damage could occur as well. Read and observe all **WARNING** statements found in your Owner's Manual and on your machine.
-  **CAUTION:** Failure to read and observe all **CAUTION** statements could result in damage to the machine or to other property. Read and observe all **CAUTION** statements found in our Owner's Manual and on your machine.

-  **DANGER:** Failure to read the Owner's Manual prior to operating or attempting any service or maintenance procedure to your Clarke machine could result in injury to you or to other personnel; damage to the machine or to other property could occur as well. You must have training in the operation of this machine before using it. If you or your operator(s) cannot read English, have this manual explained fully before attempting to operate this machine.
-  **DANGER:** Operating a machine that is not completely or fully assembled could result in injury or property damage. Do not operate this machine until it is completely assembled. Inspect the machine carefully before operation.
-  **DANGER:** Machines can cause an explosion when operated near flammable materials and vapors. Do not use this machine with or near fuels, grain dust, solvents, thinners, or other flammable materials. This machine is not suitable for picking up hazardous dust.
-  **DANGER:** Lead acid batteries generate gases which can cause an explosion. Keep sparks and flames away from batteries. Do not smoke around the machine. Charge the batteries only in an area with good ventilation. Make sure that the AC charger plug is unplugged from the wall receptacle before connecting or disconnecting the DC plug to or from the battery pack.
-  **DANGER:** Working with batteries can be dangerous! Always wear eye protection and protective clothing when working near batteries. Remove all jewelry. Do not put tools or other metal objects across the battery terminals, or the tops of the batteries.
-  **DANGER:** Using a charger with a damaged power cord could result in an electrocution. Do not use the charger if the power cord is damaged.
-  **WARNING:** Operating this machine from anywhere other than the back of the machine could result in injury or damage. Operate this machine only from the rear.
-  **WARNING:** This machine is heavy. Get assistance before attempting to transport or move it. Use two able persons to move the machine on a ramp or incline. Always move slowly. Do not turn the machine on a ramp. If operating machine on a gradient over 2%, do not stop, turn or park. Read the "Procedures For Transporting" in this manual before transporting as machine might topple over if not strapped.
-  **WARNING:** Machines can topple over if guided over the edges of stairs or loading docks and cause injury or damage. Stop and leave this machine only on a level surface. When you stop the machine, put all switches into their "OFF" position.

-  **WARNING:** Maintenance and repairs performed by unauthorized personnel could result in damage or injury. Maintenance and repairs must be performed by authorized Clarke personnel only.
-  **WARNING:** Any alterations or modifications of this machine could result in damage to the machine or injury to the operator or other bystanders. Alterations or modifications not authorized by the manufacturer voids any and all warranties and liabilities.
-  **WARNING:** Electrical components of this machine can "short-out" if exposed to water or moisture. Keep the electrical components of the machine dry. Wipe the machine down after each use. For storage, keep the machine in a dry building.
-  **WARNING:** Operating a machine without observing all labels and instructional information could result in injury or damage. Read all machine labels before attempting to operate. Make sure all of the labels and instructional information are attached or fastened to the machine. Get replacement labels and decals from your Clarke distributor.
-  **WARNING:** Wet floor surfaces can be slippery. Water solutions or cleaning materials used with this type of machine can leave wet areas on the floor surface. These areas can cause a dangerous condition for the operator or other persons. Always put "Caution" signs around/near the area you are cleaning.
-  **WARNING:** Improper discharge of waste water may damage the environment and be illegal. The United States Environmental Protection Agency has established certain regulations regarding discharge of waste water. Also, city and state regulations regarding this discharge may be in effect in your area. Understand and follow the regulations in your area. Be aware of the environment hazards of chemicals that you dispose.
-  **CAUTION:** Use of this machine to move other objects or to climb on could result in injury or damage. Do not use this machine as a step or furniture. Do not ride on this machine.
-  **CAUTION:** Your machine warranty will be voided if anything other than genuine Clarke parts are used on your machine. Always use Clarke parts for replacement.

Introduction & Machine Specifications

Introduction & Machine Specifications

Clarke's newly designed Encore S20 and L20 automatic scrubbers are efficient and superior floor cleaning machines. The Encore uses one brush to scrub a path 20 inches wide. A squeegee wipes the floor while the vacuum motor removes the dirty solution from the floor - all in one pass.

The Encore S20 and L20 automatic scrubbers come complete with two - 12 volt batteries, one battery charger, either a scrub brush or a pad driver, and one operator's manual.

SPECIFICATIONS:

Model	Encore L20 - 00880A	Encore S20 00890A	Encore L20 w/brake 00880E	Encore S20 w/brake 00890E
Motor, Vac	¾ HP three stage tangential discharge 21 Amp			
Power Supply	24 volt direct current (2) 12 Volt 195AH Batteries			
Solution Tank	14 gallons		53 Liters	
Recovery Tank	14 gallons		53 Liters	
Parabolic Squeegee	32" Hard, 34" Flex		81 cm Hard, 86 cm Flex	
Motor, Brush	.75 hp PM 33 amp			
Motor Traction	.5 hp PM (.37kw) 23 Amp	N/A	.5 hp PM (.37kw) 23 Amp	N/A
Brushes	20 inch		51 cm	
Brush Speed	200 rpm			
Brush Pressure	100 lbs.		45.36 kg	
Speed, Forward	0=250 ft/min.	brush assist.	0=76.2 m/min.	brush assist
Speed Reverse	0=190 ft/min.	N/A	0=58 m/min.	NA
Drive Wheels	8" x 2" Neoprene thread		20.32 cm s 5.08cm Neoprene thread	
Charger	24V, 25A, 115V/60hz			
Length	52½"		133.4 cm	
Width (over brush housing)	22¼"		56.5 cm	
Height	43½"		110.5 cm	
Sound Level (DBA)	74, at 5 feet		74, at 1.5 meters	
Cleaning Swath	20 inch		51 cm	
Grade Cleaning	5° Incline			
Weight	468 lbs. w/(2) 871334A batteries		212.28 kg w(2) 871334A batteries	
Shipping Weight	607 lbs. w/wet batteries		275.33 kg w/wet batteries	
Battery Weight (each)	113 lbs. (871334A) and 81 lbs. (871335A)		51.26 kg (871334A) and 36.74 kg (871335A)	
Shipping Dimensions	28" x 65.5" x 46.5"		71.12 cm x 166.37 cm x 118.11 cm	

Procedures For Transporting

How to Put the Machine Into a Van or Truck

▲ WARNING: This machine is heavy. Get assistance before attempting to transport or move it. Use two able persons to move the machine on a ramp or incline. Always move slowly. Do not turn the machine on a ramp. Do not stop and leave the machine on a ramp or incline. The loading ramp must be a minimum of 32" wide.

▲ WARNING: Machines can topple over if guided over the edges of stairs or loading docks and cause injury or damage. Stop and leave this machine only on a level surface. When you stop the machine, put all switches into their "OFF" position.

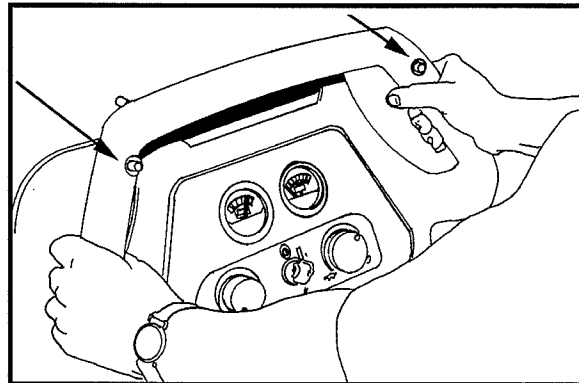

Figure #1

1. Make sure the loading ramp is at least eight (8) feet long and a minimum of 32" wide, and strong enough to support the machine.
2. Make sure the ramp is clean and dry.
3. Put the ramp in position.
4. Remove squeegee assembly, brush housing and brush or pad driver before loading.
5. Turn key switch "ON" (on L20 model only).
6. Align the machine on a level surface five (5) feet in front of the ramp.
7. Put the traverse knob at full speed (on L20 model only).
8. For the L20 machine, push in either one of the forward/reverse switches while pushing in the white reverse switch. Back the machine up the ramp. See figure 1.
9. For the S20 machine, push the machine backwards to the top of the ramp.
10. Turn the key switch "OFF".

Procedures For Transporting (cont.)

11. **Fasten the machine to the vehicle.** Clarke recommends a strap over the top of the machine and a strap to keep the machine from rolling forward or backwards. If this is not done, there is a possibility of the machine toppling over.

How to Remove the Machine From a Van or Truck

1. Make sure there are no obstructions in the area.
2. Make sure the unloading ramp is at least eight (8) feet long and a minimum of 32" wide, and strong enough to support the machine.
3. Make sure the ramp is clean and dry.
4. Put the ramp in position.
5. Unfasten the machine.

▲ WARNING: The machine is heavy. Make sure you use two able persons to assist in moving the machine down the ramp.

6. On S20 model, get two people to pull machine off ramp. It is recommended that the "S" model be unloaded in the forward position.
7. Turn the key switch "ON". ("L" model only)
8. Set the traverse center knob to the slowest forward speed setting. Carefully and slowly, drive the machine to the top of the ramp and start down.
9. While pushing in the right or left forward/reverse switch the machine will go forward. See figure 2.
10. As the machine begins to travel down the ramp, push in the forward/reverse switch to maintain a slow downward speed.
11. Replace squeegee assembly, brush housing, and brush or pad driver after machine is unloaded and ready to use.

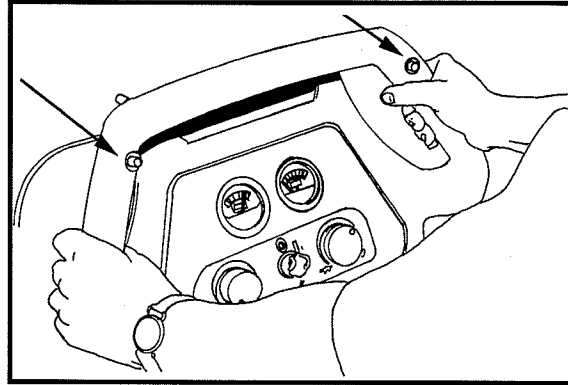

Figure #2

Machine Control Panel

Key Switch (See Figure 3, Item "A")

The key switch turns "ON" the power to the control panel. "O" is "OFF" and "I" is "ON".

Forward Reverse Switch (See Figure 3, Item "B") On Traverse Model Only

The forward/reverse switch turns the traverse motor "on" forward and if the brush motor is in the down position, activates the brush motor/solution control module. There is a two second delay for the pad motor to stop after releasing the switch. Either the right or the left switch can be used. Use either switch in conjunction with the white reverse switch to reverse the traverse motor.

Reverse Switch (See Figure 3, Item "I") On Traverse Model Only

The reverse switch, when used in conjunction with one of the forward/reverse switches, causes the machine to reverse directions. The reverse speed is 70% of the forward speed. **NOTE: Squeegee must be raised to at least the first position.**

Battery Meter (See Figure 3, Item "C")

The battery meter indicates the relative charge on the battery pack. Do not continue to run the machine when the needle is in the "red" area. This will shorten the life of the battery pack.

Brush Pressure Meter (See Figure 3, Item "D")

The pad pressure meter indicates the relative amount of pressure the pad is putting on the floor. To maximize run time on a battery charge, keep the needle towards the center of the green area.

Hour Meter (See Figure 3, Item "E")

The hour meter indicates the number of hours the machine has operated. It runs only when the brush motor is on.

Circuit Breakers (See Figure 3, Items "F", "G" & "H")

The circuit breaker reset buttons are located on the rear cover. The breakers are located as follows:

Item F - Traverse Motor (25 amp)

Item G - Vacuum Motor (30 amp)

Item H - Brush Motor (40 amp)

If a circuit breaker trips, determine which motor is not operating and turn the key switch "OFF". Wait five minutes and push the reset button back in. Turn the key switch "ON" and try again. An authorized service person should be contacted if the breaker trips again.

Control Handles (See Figure 3, Item "I")

The control handles are located at the rear of the machine. They are used to guide the machine.

Solution Control Knob (See Figure 3, Item "J")

The solution control knob regulates the flow of chemical solution to the floor. To increase the flow, turn knob clockwise. To decrease the flow, turn counter clockwise.

Traverse Speed Knob (See Figure 3, Item "K")

To increase speed, turn knob clockwise.

Vacuum Motor Switch (See Figure 4, Item "L")

To activate vacuum motor, lower squeegee handle. Handle has two positions. Lowest position is operating position and the middle position is transport to clear vacuum hose.

Brush Motor Switch (See Figure 4, Item "M")

To activate brush motor, lower handle. Brush Motor and solution flow will activate when the traverse buttons are pushed. To shut brush motor off, raise handle to top position.

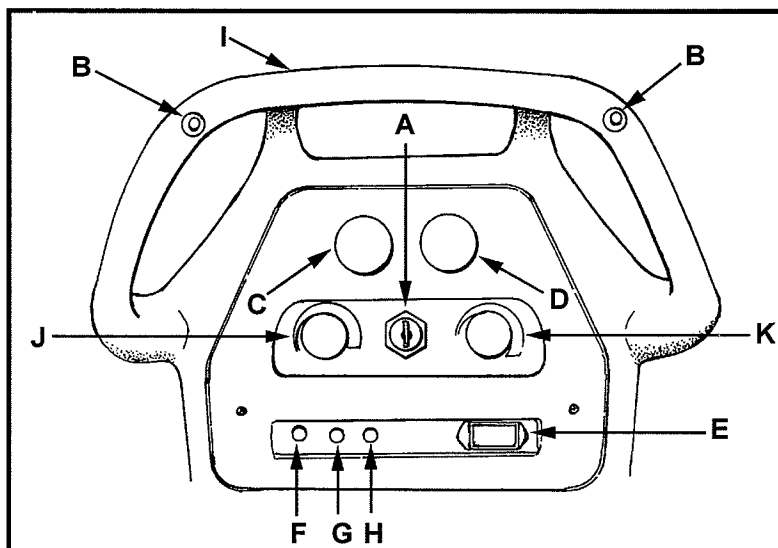

Figure 3

Machine Controls and Features

Squeegee Lift Handle. See Figures 5

The squeegee lift handle is located below the control handles in the center. It is used to raise or lower the squeegee. The vac motor is turned on when the handle is lowered to either the first or last position.

NOTE: Squeegee must be raised to at least the first position when the machine is backed up.

Float Shut Off. See Figure 6

The shut-off switch for the vac motor is located in the recovery tank. It automatically turns off the vac motor when the recovery tank is full. **NOTE: If excessive foaming in recovery tank, defoamer must be added. Damage to vacuum motor could result from foam.**

Parking Brake. See Figures 7a and 7b (Optional)

The parking brake prevents movement of the machine. It is located at the rear lower left side of the machine. To engage the brake, push the pedal down (Figure 7a). To release the brake, lift pedal up (Figure 7b).

▲ CAUTION: Do not activate the brake while the machine is moving.

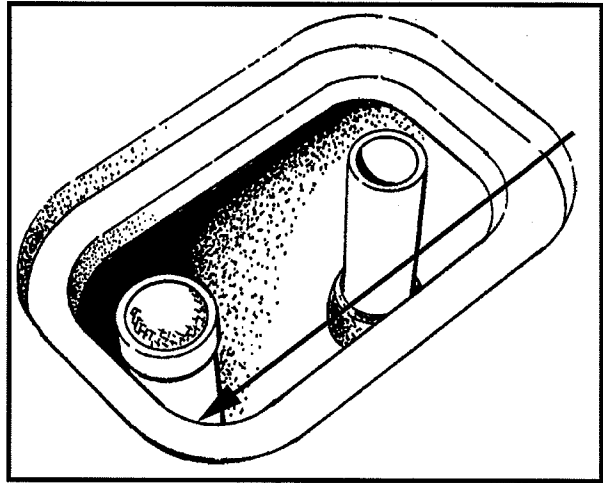

Figure 6

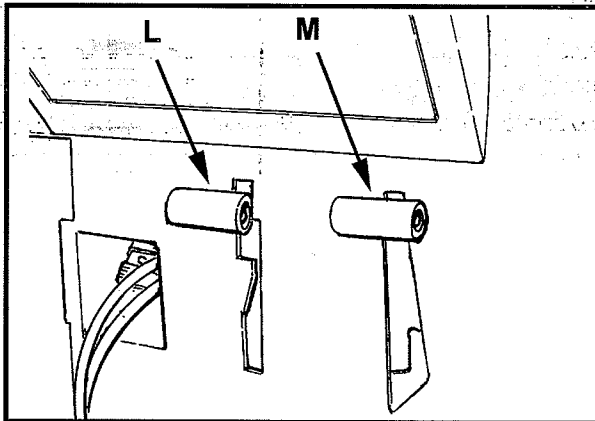

Figure 4

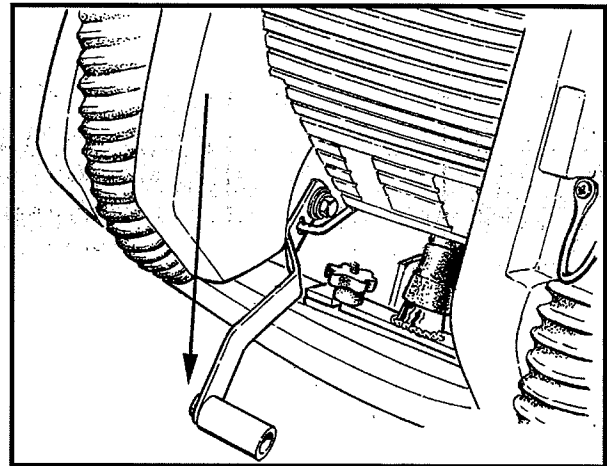

Figure 7a

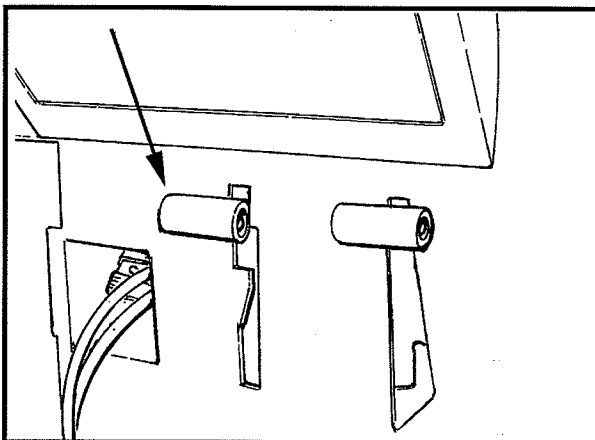

Figure 5

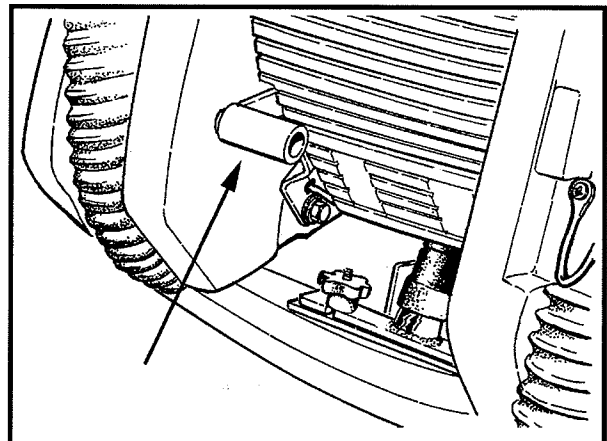

Figure 7b

How To Prepare the Machine For Operation

How To Install The Batteries

The Encore machines uses two 12-volt batteries. The batteries are located in the battery compartment under the recovery tank.

To install the batteries, follow this procedure:

1. Turn machine off. Set brake (if equipped).
2. Make sure recovery tank is empty.
3. Open recovery tank and secure with latch.
4. Place the batteries in the tray as shown in figure 8.

WARNING: Lifting batteries without help could result in an injury. Get help to lift the batteries. The batteries are heavy.

WARNING: Working with batteries can be dangerous. Always wear eye protection and protective clothing when working near batteries. **NO SMOKING!**

5. Connect the battery cables between batteries and install long battery cable assembly as indicated. See figure 8.
6. Join the connector from the battery pack to the connector on the control panel. See figure 9.
7. Lower recovery tank.

NOTE: Charge the batteries before using the machine.

Battery Maintenance

The electrical power to operate the machine comes from the storage batteries. Storage batteries need preventative maintenance.

WARNING: Working with batteries can be dangerous. Always wear eye protection and protective clothing when working near batteries. **NO SMOKING!**

To maintain the batteries in good condition, follow these instructions:

1. Keep the electrolyte at the correct level. The correct level is between 1/4" below the bottom of the tube in each cell and above the tops of the plates. Check the level of the electrolyte each time you charge the batteries. See figure 10.

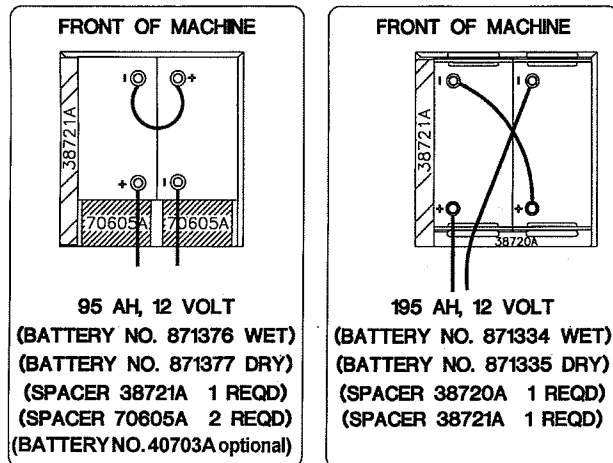

Figure 8

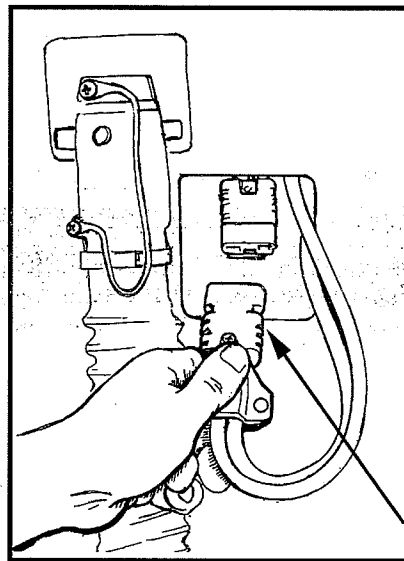

Figure 9

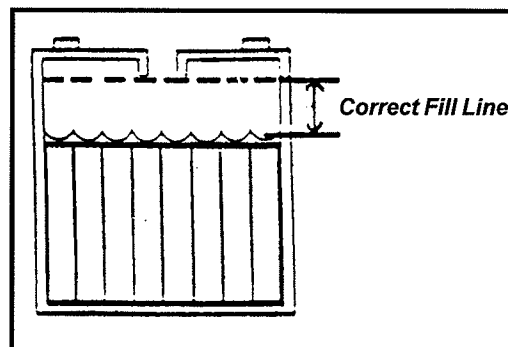

Figure 10

How To Prepare the Machine For Operation

NOTE: Check the level of electrolyte prior to charging the batteries. Be sure the plates in each cell are covered with electrolyte. Do not top off the cells prior to charging the battery. Electrolyte expands during charging. As a result, the electrolyte could overflow from the cells. Always top off the cells with distilled water after charging.

CAUTION: Irreversible damage will occur to the batteries if the electrolyte level does not cover the plates. Keep the electrolyte at the correct level.

CAUTION: Machine damage and discharge across the tops of the batteries can occur if the batteries are filled above the bottom of the tube in each cell. Do not fill the batteries up to the bottom of the tube in each cell. Wipe any acid from the machine or the tops of the batteries. Never add acid to a battery after installation.

CAUTION: Tap water may contain contaminants that will damage batteries. Batteries must be refilled with distilled water only.

2. Keep the tops of the batteries clean and dry. Keep the terminals and connectors clean. To clean the top of the batteries, use a damp cloth with a weak solution of ammonia or bicarbonate of soda solution. To clean the terminals and connectors, use a terminal and connector cleaning tool. Do not allow ammonia or bicarbonate of soda to get into batteries.
3. Keep the batteries charged.
4. To drain battery compartment: (See figure 11)
 - a. Always wear protective eye protection and protective clothing.
 - b. Open brush motor cover.
 - c. Loosen the drain hose clip with a Phillips screw driver.
 - d. Pull drain hose out to a container.
 - e. Place hand behind flange and open valve.
 - f. When empty, close valve.
 - g. Replace hose under clip and retighten clip.
 - h. Neutralize any acid spills.

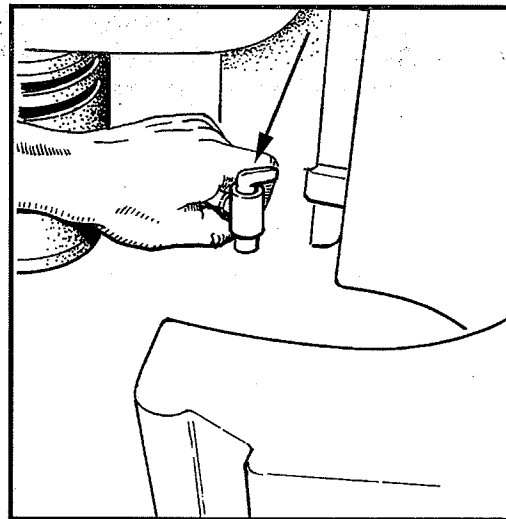

Figure 11

How To Prepare the Machine For Operation

How To Charge The Batteries

⚠ WARNING: Charging the batteries in an area without adequate ventilation could result in an explosion. To prevent an explosion, charge the batteries only in an area with good ventilation.

⚠ WARNING: Lead acid batteries generate gases which could explode. Keep sparks and flames away from batteries. **NO SMOKING!**

⚠ WARNING: Failure to disconnect the AC plug from the wall receptacle before connecting or disconnecting the DC connector on the charger could result in an explosion. Always disconnect the AC plug from the wall receptacle before connecting or disconnecting the DC connector on the charger.

To charge the batteries, follow this procedure:

1. Put the charger on a flat surface. Make sure the vents on the sides are at least two inches away from walls and other objects. Make sure there are no objects near the vents on the bottom of the charger.
2. Set the parking brake (if provided) by putting it into the down position. See figure 12. Make sure the key switch is in "OFF" position.
3. Disconnect the battery pack connector from the control housing connector. See figure 13.
4. Raise recovery tank and latch in place.
5. Connect the DC connector on the charger to the battery pack connector. See figure 14.
6. Connect the charger to a properly grounded single phase (3-wire) wall receptacle having the voltage, frequency, and ampere capacity specified on the nameplate of the charger.

For more information on the use of the charger, read the instruction book supplied with the charger.

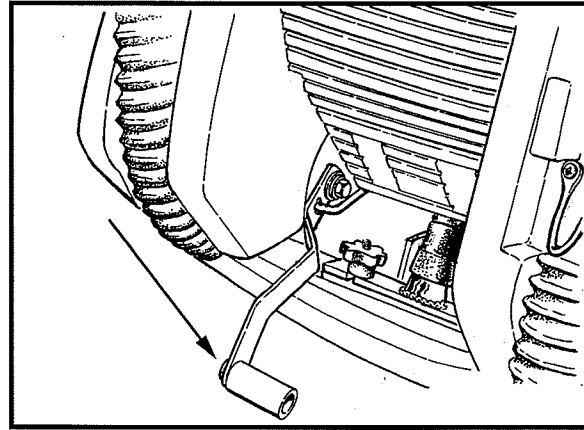

Figure 12

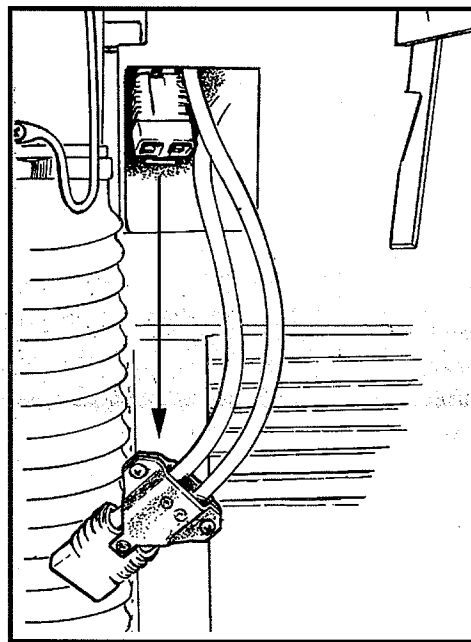

Figure 13

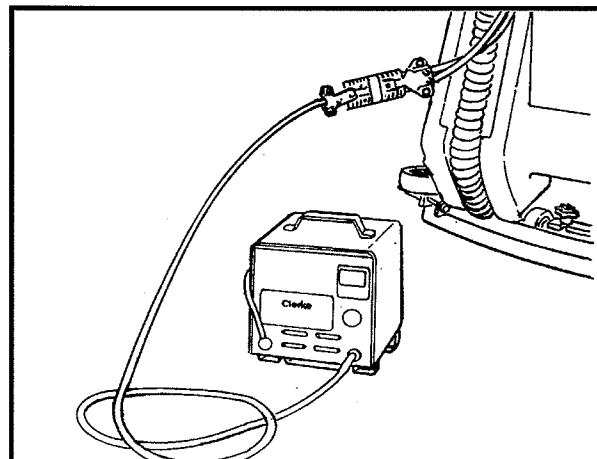

Figure 14

How To Prepare the Machine For Operation

How To Install The Brush Or Pad Driver

To install the brush or pad driver on the machine, follow this procedure:

1. Turn the key switch "OFF".
2. Put the brush switch in the "UP" position.
3. Go to the front of the machine.
4. Open the brush motor cover and remove the brush housing. See figures 15a and 15b.
5. Put a brush or pad driver under the brush housing. See figure 15c.
6. Align the lugs on the motor with the slots in the brush gimbal.
7. Pull the brush up and rotate counter clockwise until gimbal locks.
8. Replace brush housing and close brush motor cover.

How To Remove The Brush or Pad Driver

To remove the brush or pad driver from the machine, follow this procedure:

1. Put the brush switch in the "UP" position.
2. Turn the key switch "OFF".
3. Go to the front of the machine.
4. Open the brush motor cover and remove brush housing. See figures 15a-15c.
5. Rotate brush clockwise with a quick snapping action until brush releases.
6. Replace brush housing and close brush motor cover.

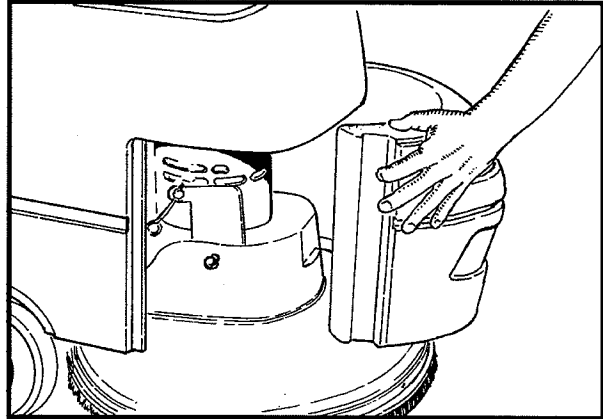

Figure 15a

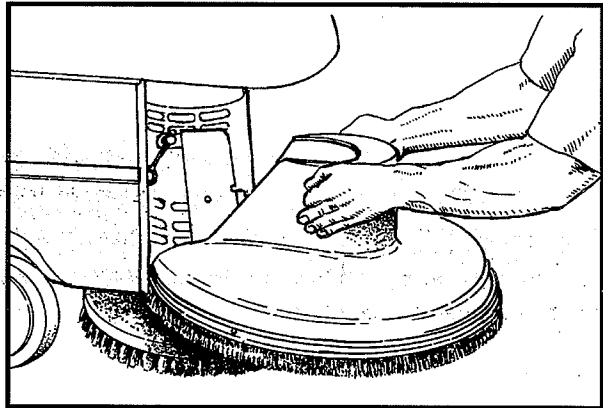

Figure 15b

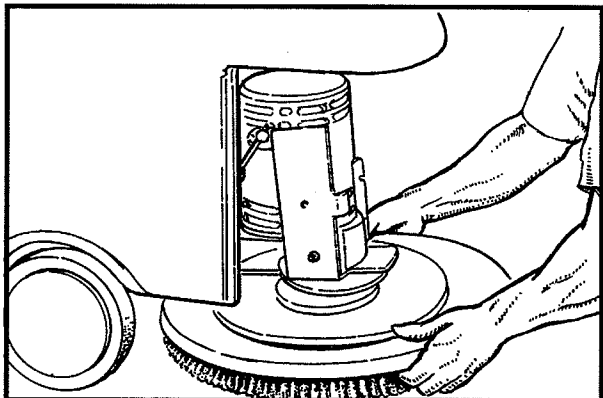

Figure 15c

How To Operate The Machine

How To Operate The Squeegee

The squeegee wipes the floor while the vacuum motor removes the dirty solution from the floor. Use your right hand to lower or raise the squeegee handle. To operate the squeegee, follow this procedure:

1. To lower the squeegee and start the vac motor, move the squeegee lever to the right and down. See figure 16.
2. To raise the squeegee, lift the squeegee lever up. See figure 17.

NOTE: The center position lets the vac motor continue to run with the squeegee off the floor to avoid drips and also allows you to back up the machine.

How To Fill The Solution Tank

The solution tank lid is at the front. To fill the solution tank follow this procedure:

1. Raise the solution tank lid.
2. Add a cleaning chemical to the solution tank. For the correct amount of chemical, follow the directions shown on the container.
3. Fill the solution tank with water.
4. Lower the solution tank lid.

⚠ WARNING: Water solutions or cleaning materials used with this type of machine can leave wet areas on the floor surface. These areas can cause a dangerous condition for the operator or other persons. Always put CAUTION signs near the area you are cleaning.

⚠ WARNING: Machines can ignite flammable materials and vapors. Do not use with or near flammables such as gasoline, grain dust, solvents and thinners. Only use a cleaning concentrate recommended by the chemical manufacturer.

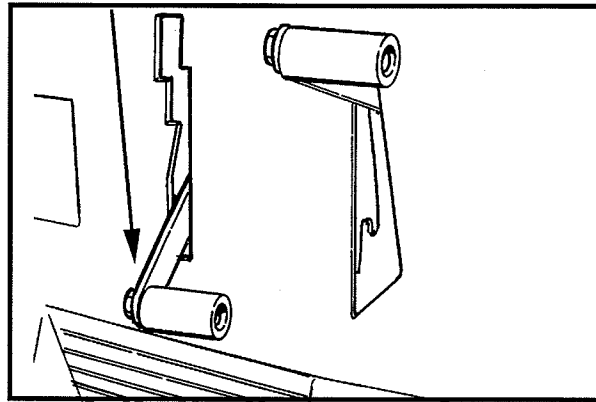

Figure 16

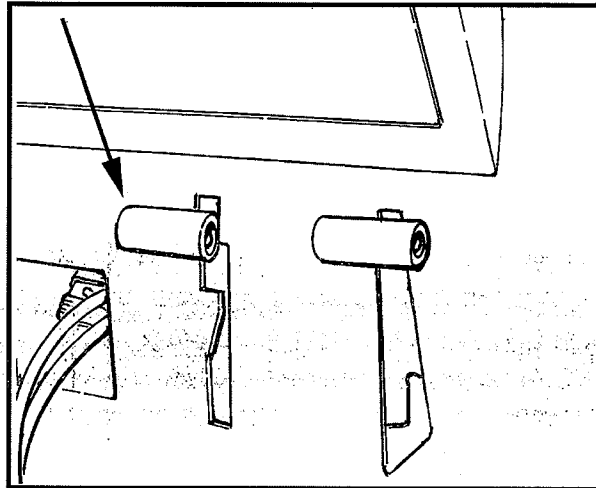

Figure 17

How To Operate The Machine

Operating The Machine

NOTE: Put the machine in the lowest traverse speed setting. Use the machine in an area that has no furniture and objects until you can do the following:

1. Move the machine in a straight direction, forward and backward.
2. Stop the machine safely.
3. Turn the machine both left and right and return to a straight direction.

To move the machine, follow this procedure:

1. Release the parking brake (if equipped with machine).
2. Turn the key switch to the "ON" position
3. Raise the brush to the highest setting.
4. Raise the squeegee.
5. Hold the control handle as shown in figure 18.
6. When either the right or left forward/reverse switches (figure 18, item A) are pushed in, the machine will go forward.
7. Control the speed of traverse by using the speed control knob. (Figure 18, Item D)
8. To stop, release the forward/reverse switch.
9. To reverse the machine, push in the white reverse switch (figure 18 item B) and either the right or left forward/reverse switch (figure 18 item A) at the same time. **NOTE: Anytime the machine is reversed, the squeegee must be raised to either of the two up positions. This will prevent damage to the squeegee.**
10. To stop, release the forward/reverse switch.
11. To turn the machine, push the rear of the machine to the side.
12. When you stop the machine, turn the key switch "OFF" and set the parking brake (if equipped).

Adjusting The Brush Pressure

WARNING: Make sure the battery connector covers are on before making adjustments. Don't let metal parts touch the battery connections.

1. To increase or decrease the brush pressure for "Heavy Scrub", raise the recovery tank to gain access to the adjustment.
2. Turn the brush lift spring lock nut (figure 19) clockwise for more pressure and counterclockwise for less pressure. Use the brush pressure meter (figure 18, Item C) to determine the best setting. The needle should stay in the green area.

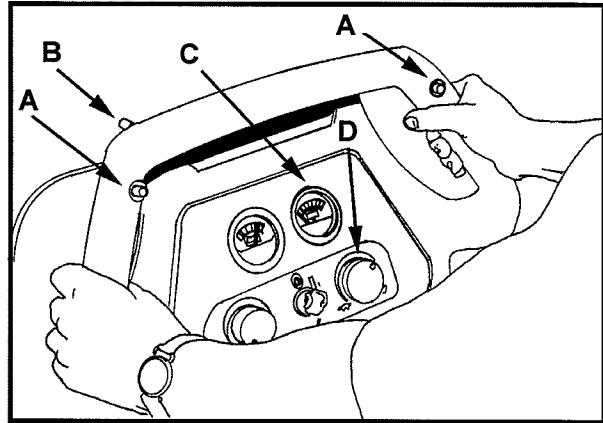

Figure 18

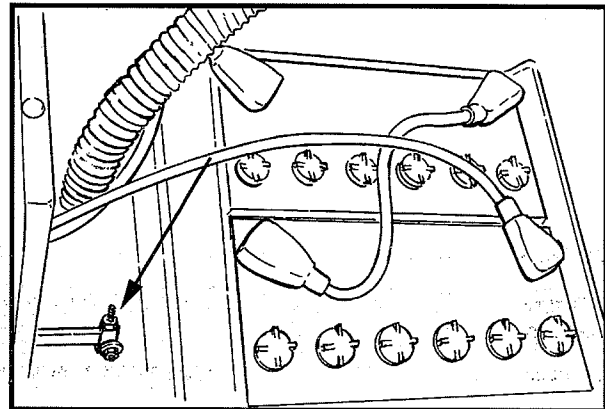

Figure 19

How To Operate The Machine (cont)

How To Clean A Floor

WARNING: Water solutions or cleaning materials used with this type of machine can leave wet areas on the floor surfaces. These areas can cause a dangerous condition for the operator or other persons. Always put CAUTION signs near the area you are cleaning.

To clean a floor follow this procedure:

1. Set the parking brake (if equipped with machine.)
2. Put the water and a cleaning chemical in the clean solution tank.
3. Release the parking brake (if equipped with machine.)
4. Turn the key switch "ON".
5. Lower the squeegee.
6. Put the brush lever switch in the floating position or heavy scrub position.

NOTE: Keep the machine moving when the brush is rotating on the floor. Pre-wet brush/pad or keep light pressure on brush until solution flow is adequate to keep brush/pad from scratching floor.

7. Turn the solution knob to the right to activate the flow of solution. Adjust the flow of clean solution to the flow desired.
8. Move the machine across the floor in the forward direction.
9. Make a 180° turn.

NOTE: When you make more passes across the floor, let the brush clean approximately 2 inches of the area already cleaned by the brush.

NOTE: During most cleaning procedures, apply and remove the solution in one operation.

How To Clean A Very Dirty Floor

To clean a very dirty floor, follow this procedure:

1. Apply solution to the floor.
2. Do not lower the squeegee, which will keep the vacuum motor off.
3. Lower the brush or pad and scrub the floor.
4. Scrub the floor again with additional solution and lower the squeegee.
5. Pick up all the solution with the squeegee.

Clarke[®]

ENCORE

S20/L20

Section II

Parts and Service Manual

(70659A)

U.S. Patent No. 5,383,251; No. 6,105,192; No. 6,557,207; & Patent Pending

HOW TO CORRECT PROBLEMS IN THE MACHINE

PROBLEM	CAUSE	ACTION
There is no solution flow.	The solution valve is closed.	Open the solution valve.
	There is an obstruction in the solution hose or filter.	Remove the obstruction from the hose and the filter.
	The solution valve or electric wiring is damaged.	Repair or replace the valve and the electric wiring.
	The solution tank is empty.	Fill the solution tank.
	The solution module is damaged.	Check solution module
The solution flow does not stop.	The solution valve is open or dirty.	Close or Clean the solution valve.
	The solution valve or wiring is damaged.	Repair or replace the valve and the wiring.
	The solution valve is dirty	Clean the solution valve.
	There is a damaged seat and washer in the solution valve.	Replace the seat and washer.
	The solution module is damaged.	Check solution module.
The machine does not remove all the water from the floor.	The squeegee is up	Lower the squeegee.
	The squeegee tilt is not correct.	(See Figure 11, page 23)
	The vacuum tank is full.	Drain the tank.
	The screen filter is dirty.	Clean the screen filter.
	There is an obstruction or damage in the squeegee, squeegee hose or standpipe.	Remove the obstruction or repair the damage.
	The vacuum motor is not running.	Check for tripped breaker. Have an authorized service person make repairs.
	The vacuum motor runs slow	See pg 49 for brush replacement intervals.
	The squeegee hose is disconnected, or damaged	Check and connect hose.
	The squeegee blade is damaged, worn, or incorrectly installed.	Turn or replace the squeegee blade. Correctly install the squeegee blade.
	The squeegee pressure is not correctly adjusted.	Adjust the pressure of the squeegee.
The gaskets on the cover of the recovery tank are damaged.	Replace the gaskets.	
The batteries do not give the normal running time.	The recovery tank lid is on wrong.	Rotate lid 180° and replace.
	The battery terminals are dirty or damaged.	Clean the terminals and connectors. Replace the damaged cables. Charge the batteries.
	The electrolyte level is too low.	Add distilled water to each cell and charge the batteries.
	The batteries are not fully charged.	Charge the batteries for a full 16 hour charge.
	The charger is damaged.	Have an authorized service person repair the charger.
	The battery is defective.	Check voltage of each cell while discharging.
	The batteries are disconnected.	Connect the batteries.
Brush is in heavy scrub setting.	Run in float position.	

PROBLEM	CAUSE	ACTION
<p>The cleaning is not even.</p>	<p>The scrub brush or pad is worn.</p> <p>There is damage to the brush assembly, caster or the solution valve.</p> <p>The brush motor is not running</p> <p>The solution level is low.</p>	<p>Replace the scrub brush or pad.</p> <p>Have an authorized service person make the needed repairs.</p> <p>Check for tripped breaker. Reset. Check for loose connections.</p> <p>Fill the solution tank.</p> <p>NOTE: If the problem continues consult an authorized service person.</p>
<p>The machine does not run.</p>	<p>The machine loses power.</p> <p>Key or switch is off.</p> <p>Batteries are unplugged. Battery terminals are dirty.</p> <p>Batteries are discharged</p>	<p>Reset the circuit breaker.</p> <p>Turn key or switch on.</p> <p>Check the battery connections.</p> <p>Check battery gauge and recharge</p> <p>NOTE: If the problem continues consult an authorized service person.</p>

MAINTENANCE

- ▲ **WARNING:** Maintenance and repairs must be done by authorized personnel only.
- ▲ **WARNING:** Always empty the solution tank and recovery tank before doing any maintenance.
- ▲ **WARNING:** Keep all fasteners tight.

These Maintenance Procedures Must Be Done Every Day

Keep the machine clean, it will need fewer repairs and have longer life.

Do These Procedures When You Begin Your Work Period

NOTE: Always engage the parking brake (if equipped) before servicing the machine.

1. Disconnect the plug on the charger from the connector on the back of the machine. See figure 1
2. Join the connector from the batteries (1) to the control panel cable connection. See figure 1.
3. Make sure the recovery tank lid is on correctly. See figure 2.
4. Make sure the Screen filter over the vacuum motor is clean and in position. See figure 2 (a)
5. Make sure the valves on the drain hoses are clean. Tightly close the valves.
6. Make sure brush housing and skirt are in position on the brush head.
7. Make sure the brush is in position and installed correctly
8. Check the installation of the squeegee and squeegee hose.

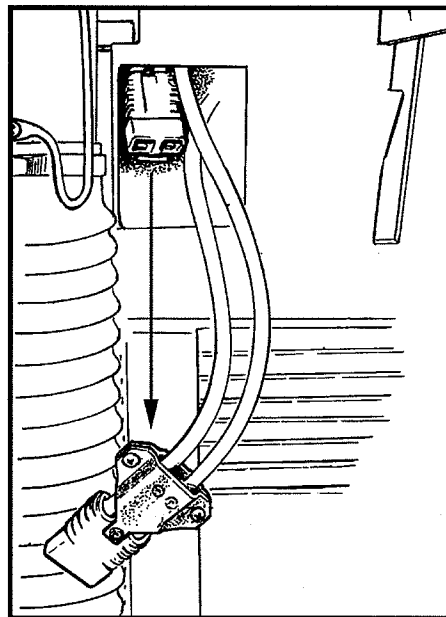

Figure 1

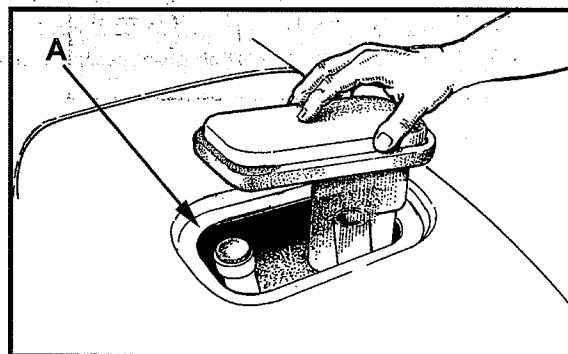

Figure 2

MAINTENANCE

Do These Procedures When You End Your Work

NOTE: Always engage the parking brake (if equipped) before servicing the machine.

1. Drain the solution tank (Figure 3) and the recovery tank (Figure 4). To drain the tanks, follow this procedure:

- a. Turn the key switch "OFF".
- b. Remove the drain hose from the back of the machine.
- c. Put the end of the hose over a drain or bucket.
- d. Turn the valve handle to the left. Pull the handle out to open the drain. (Figure 5)

NOTE: Have the opening in the side of the valve away from you when you open the valve.

- e. To open the valve completely, turn the handle to the right. Pull the handle out of valve. (Figure 6)
2. Flush the tanks. To flush the tanks, put clean water in the tank through the opening on top of the tank.

CAUTION: Make sure water or solution does not enter the opening for the vacuum motor. See figure 2.

3. If a tank or drain hose has an obstruction, use a high pressure water hose to flush the tank or hose. Put the water hose into the drain hose.
4. Leave the tanks and the drain valves open to dry in the air.
5. Check the squeegee blade. Use a cloth to clean the squeegee blade. If the squeegee blade is damaged or worn, turn or replace the blade.
6. Check and clean the solution lid gasket. Use a mild cleaning solution and rinse the parts in clean water.

Check the batteries and add distilled water as needed. The correct level is within 1/4 inch of the bottom of the tube in each cell.

CAUTION: Tap water may contain contaminants that will damage batteries. Batteries must be refilled with distilled water only.

WARNING: Lead acid batteries generate gases which can cause an explosion. NO SMOKING. Always wear eye protection and protective clothing when working near batteries.

Use a clean cloth and wipe the surface of the machine.

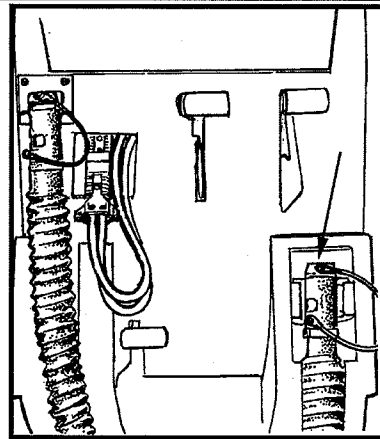

Figure 3

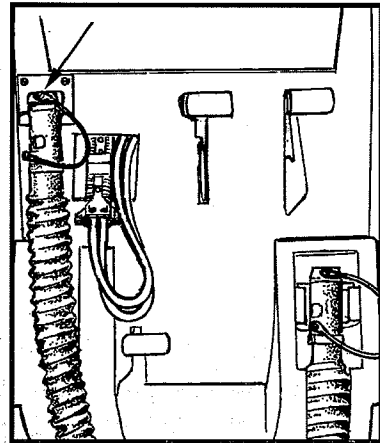

Figure 4

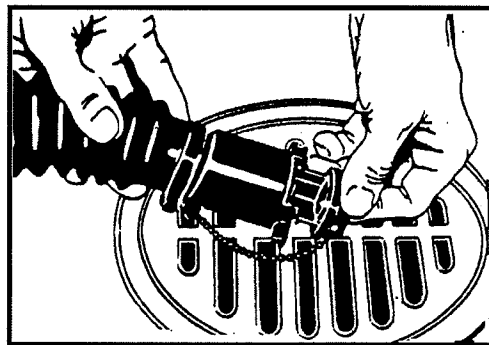

Figure 5

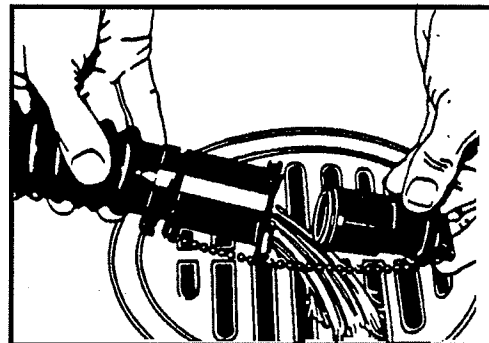

Figure 6

MAINTENANCE

These Maintenance Procedures Must Be Done Every Week:

⚠ WARNING: Maintenance and repairs must be done by authorized personnel only. Always empty the solution tank and the recovery tank before doing any maintenance. Keep all fasteners tight.

⚠ WARNING: Always wear eye protection and protective clothing when working near batteries. Do not put tools or other metal objects across the battery terminals or the tops of the batteries.

⚠ CAUTION: To prevent damage to the machine, and discharge across the tops of the batteries, do not fill the batteries above the bottom of the tube in each cell. Wipe any acid from the machine or the tops of the batteries. Do not add acid to battery after installation.

⚠ WARNING: Always wear eye protection and protective clothing when working near batteries. **NO SMOKING!**

1. To inspect batteries, tip up recovery tank and latch the stop to hold the tank up. See Figure 7.
2. Disconnect the batteries. Use a cloth and a solution of ammonia or bicarbonate of soda to wipe the top of the batteries. Clean the battery terminals. Reconnect the batteries.
3. Check the hoses for leaks, obstructions and other damages.
4. Check and clean the filter screen in the solution hose. To clean the screen, follow this procedure: (See figures 13 and 14 page 24)
 - a. Turn the connector to the left.
 - b. Remove and clean the filter screen.
 - c. Install the filter screen in the hose. Turn the connector to the right to connect the hose.
5. Use a grease gun to lubricate the caster. See figure 8.
6. Check the squeegee and the scrub brush or the pad driver for damage.
7. Check the squeegee and the vacuum hose for damage, leaks and obstructions.

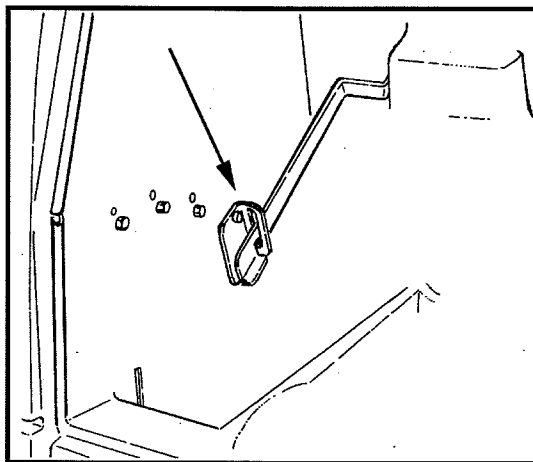

Figure 7

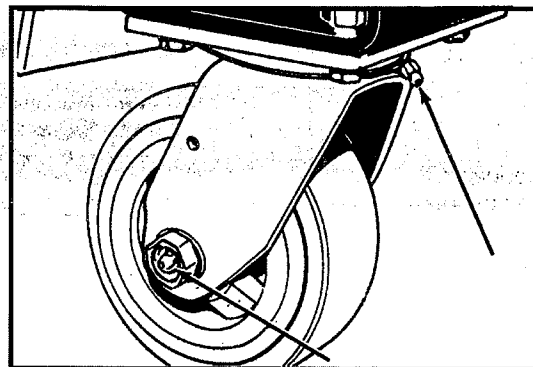

Figure 8

MAINTENANCE

Maintenance For The Squeegee

To remove the squeegee, follow this procedure:

1. Remove the squeegee assembly by loosening the two knobs that attach the squeegee to the machine. Pull the squeegee assembly off. See figure 9.
2. Inspect the squeegee blade.
3. If the blade is worn, turn the blade so that a new edge is in the wiping position.
4. Reinstall squeegee assembly on the machine.

How To Adjust The Squeegee

The following adjustments are set at the factory, however they may require slight adjustment.

Adjusting Squeegee Pressure:

To adjust the pressure, refer to Figure 10. Proper adjustment will produce a uniform flare along the rear blade when the machine is moved forward. To increase pressure, loosen bolt and slide squeegee mount down. To decrease the pressure, loosen the bolt and slide squeegee mount up.

Adjusting Squeegee Tilt:

The tilt of the squeegee causes the rear blade to raise up in the center or on the ends, depending on which direction the tilt is changed. For tilt adjustment, refer to figure 11. Loosen left and right screw "X". In order to bring the rear blade down in the center, tip "Y" down. To bring both ends down, tip "Y" up. Make very small adjustments and try it until a uniform flare is achieved. Changing the tilt may also require readjusting the squeegee pressure.

Adjusting Squeegee Swing:

The factory sets the squeegee swing for using the 33" squeegee. If you are using the optional 29" squeegee, the stop screws (page 35, ref. #20) must be adjusted in. This is done by loosening the jam nut (page 35, ref. #10); turning the screw in; and then retightening the nut. The squeegee (29" or 33") is properly adjusted when it will swing all the way left or right to within 3/4" of the drive wheels without hitting them.

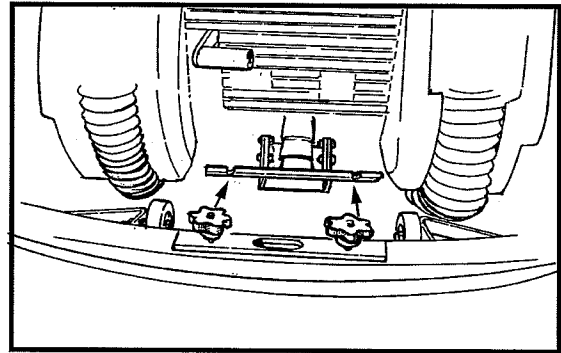

Figure 9

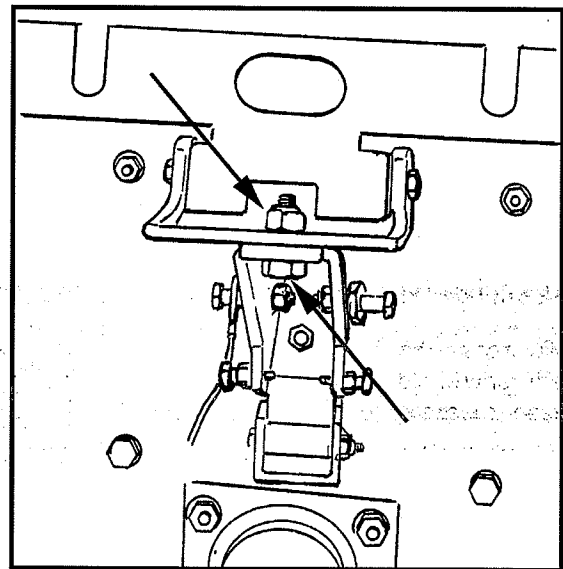

Figure 10

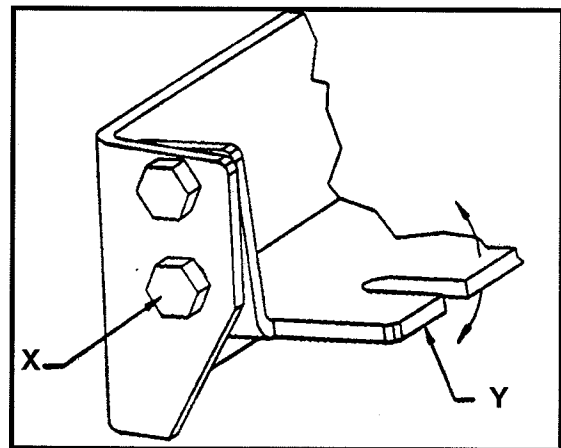

Figure 11

MAINTENANCE

Adjusting Squeegee Blades:

When properly installed the front blade should be approximately .06 above the rear blade. See figure 12.

Adjusting Squeegee Support Wheels:

The support wheels should be set at .12 above the floor with the rear blade touching the floor. See figure 12.

▲ WARNING: Maintenance and repairs must be done by authorized personnel only .

▲ WARNING: Electrical repairs must be done by authorized personnel only.

Consult your Clarke Authorized Service Person to do the service procedures.

Use only genuine Clarke parts.

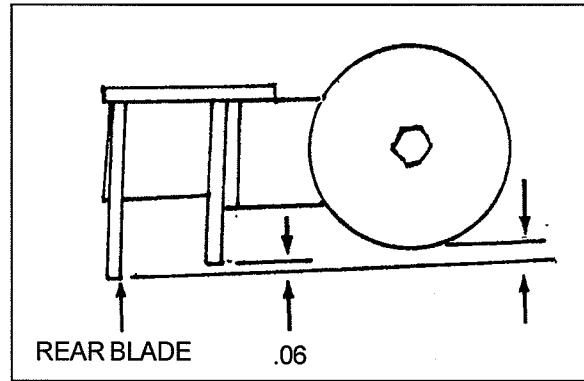

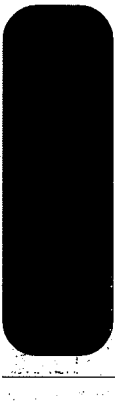
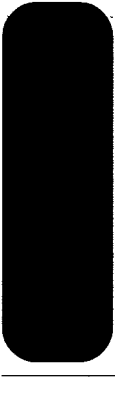



Figure 12

Encore L20 9/02
Machine Variables and Accessories

Battery Traverse - 115V		<i>Breakdown:</i>	00880A 871334 51447D 40512A	Encore L20 Base Machine Battery, 195 AH, Wet, 12 Volt (2) 20" Polypropylene Brush 24 VDC, 25 Amp, 115V/60 Hz Battery Charger
		<i>Breakdown:</i>	00880A 871334 51453D 40512A	Encore L20 Base Machine Battery, 195 AH, Wet, 12 Volt (2) Pad Driver 24 VDC, 24 Amp, 115V/60 Hz Battery Charger
Battery Traverse - 230V		<i>Breakdown:</i>	00880A 871335 51447D 40513A	Encore L20 Base Machine Battery, 195 AH, Dry, 12 Volt (2) 20" Polypropylene Brush 24 VDC, 25 Amp, 230V/50 Hz Battery Charger
		<i>Breakdown:</i>	00880A 871335 51453D 40513A	Encore L20 Base Machine Battery, 195 AH, Dry, 12 Volt (2) Pad Driver 24 VDC, 25 Amp, 230V/50 Hz, Battery Charger
Battery Traverse 115V		<i>Breakdown:</i>	00880A 871376 51447D 40520A	Encore L20 Base Machine Battery, 95 AH, Wet, 12 Volt (2) 20" Polypropylene Brush 24 VDC, 8 Amp, 115/60 Hz Battery Charger
		<i>Breakdown:</i>	00880A 871376 51453D 40520A	Encore L20 Base Machine Battery, 95 AH, Wet, 12 Volt (2) Pad Driver 24 VDC, 8 Amp, 115/60 Hz Battery Charger
Battery 230		<i>Breakdown:</i>	00880A 871377 51447D 40521A	Encore L20 Base Machine Battery, 95 AH, Dry, 12 Volt (2) 20" Polypropylene Brush 24 VDC, 8 Amp, 230V/50 Hz Battery Charger
		<i>Breakdown:</i>	00880A 871377 51453D 40521A	Encore L20 Base Machine Battery, 95 AH, Dry, 12 Volt (2) Pad Driver 24 VDC, 8 Amp, 230V/50 Hz Battery Charger

**Encore S20 9/02
Machine Variables and Accessories**

Battery 115V		<i>Breakdown:</i>	00890A	Encore S20 Base Machine
			871334	Battery, 195 AH, Wet, 12 Volt (2)
			51447D	20" Polypropylene Brush
			40512A	24 VDC, 25 Amp, 115/60 Hz Battery Charger
<hr/>				
		<i>Breakdown:</i>	00890A	Encore S20 Base Machine
			871334	Battery, 195 AH, Wet, 12 Volt (2)
			51453D	Pad Driver
			40512A	24 VDC, 25 Amp, 115/60 Hz Battery Charger
<hr/>				
Battery 230V		<i>Breakdown:</i>	00890A	Encore S20 Base Machine
			871335	Battery, 195 AH, Dry, 12 Volt (2)
			51447D	20" Polypropylene Brush
			40513A	24 VDC, 25 Amp, 230V/50 Hz Battery Charger
<hr/>				
		<i>Breakdown:</i>	00890A	Encore S20 Base Machine
			871335	Battery, 195 AH, Dry, 12 Volt (2)
			51453D	Pad Driver
			40513A	24 VDC, 25 Amp, 230V/50 Hz Battery Charger
<hr/>				
Battery 115V		<i>Breakdown:</i>	00890A	Encore S20 Base Machine
			871376	Battery, 95 AH, Wet, 12 Volt (2)
			51447D	20" Polypropylene Brush
			40520A	24 VDC, 8 Amp, 115V/60 Hz Battery Charger
<hr/>				
		<i>Breakdown:</i>	00890A	Encore S20 Base Machine
			871376	Battery, 95 AH, Wet, 12 Volt (2)
			51453D	Pad Driver
			40520A	24 VDC, 8 Amp, 115V/60 Hz Battery Charger
<hr/>				
Battery 230V		<i>Breakdown:</i>	00890A	Encore S20 Base Machine
			871377	Battery, 95 AH, Dry, 12 Volt (2)
			51447D	20" Polypropylene Brush
			40521A	24 VDC, 8 Amp, 230V/50 Hz Battery Charger
<hr/>				
		<i>Breakdown:</i>	00890A	Encore S20 Base Machine
			871377	Battery, 95 AH, Dry, 12 Volt (2)
			51453D	Pad Driver
			40521A	24 VDC, 8 Amp, 230V/50 Hz, Battery Charger

Accessories

ACCESSORIES

<u>Description</u>	<u>Part No.</u>
Pad Driver, Dual Direction	51453D
Base	57370A
Retainer	57369A
Pad/Brush Clutch Plate Metal	66649A
Spacer (for Clutch Plate 66649A)	58531A
Dual Direction Clutch Plate	30034A
Spacer (for Clutch Plate 30034A)	58530A
Clutch Plate Screws	962819
Clutch Plate Nuts	80084A
Grit Brush Dual Direction	51450D
Poly Brush Dual Direction	51447D
Clean Grit Dual Direction	51474D
Nylon Brush .016 Dual Direction	51482D
Kit, Conversion from metal to Dual Direction Clutch Plate	10055A
Power Wand Kit	10662A
ESP Recycle System Kit	10663A
Clarke Care Kit	14607A
Hour Meter Kit	10656A
29" Squeegee Kit	18820A
32" Squeegee Kit	10129A
Polydur, Protectant	50478A
Kit, Grease Gun	55420A
Kit, Low Voltage Cut-off 24 Volt	14097A
Brush Meter Option	10667A
Electronic Solution Module	10669A
Brake Option	10635A

Pads by Case

<u>Color</u>	<u>2000</u>
Yellow	979199
White	976067
Red	976068
Green	976169
Blue	976069
Brown	976070
Black	976170
Ultra H.S.	979206

Clarke®
 Encore S20 / L20
 Final Assembly Drawing 8/04

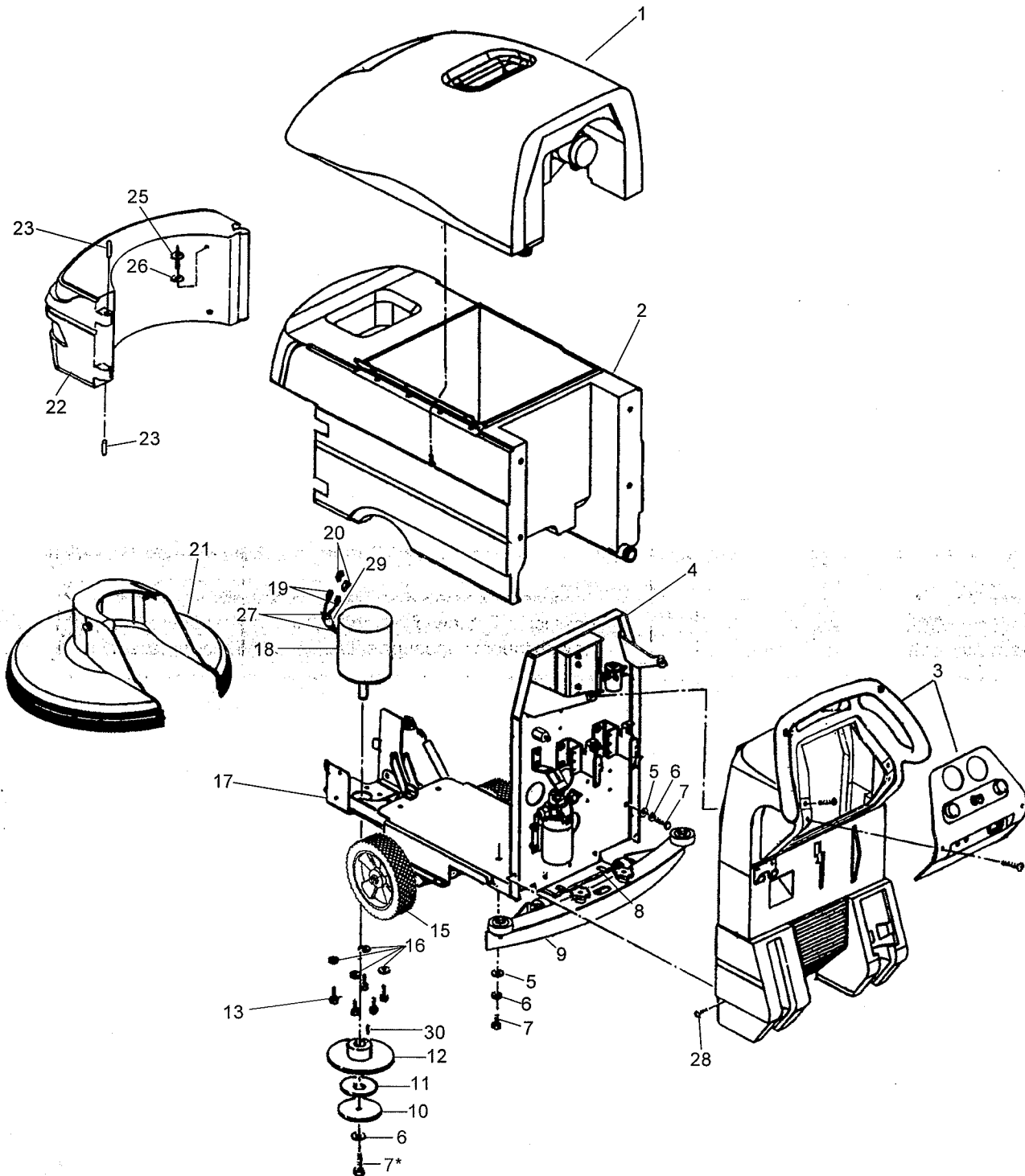

* Recommended 12 ft. lbs torque, also apply blue loctite.

Clarke®
Encore S20 / L20
Final Assembly Parts List 3/06

Ref #	Part No.	Description	Qty. L20	Qty. S20
1	Page 30	Tank Asm., Recovery	Ref.	Ref.
2	Page 32	Tank Asm., Solution	Ref.	Ref.
3	Pg 58, 66	Cover Asm., Electrical	Ref.	Ref.
4	Pg 56, 64	Panel Asm., Rear	Ref.	Ref.
5	980651	Washer, Flat, $\frac{5}{16}$	8	8
6	980652	Washer, Lock, $\frac{5}{16}$	9	9
7	85811A	Screw, $\frac{5}{16}$ -18 x $\frac{3}{4}$	9	9
8	Page 34	Lift Asm., Squeegee	Ref.	Ref.
9	Pg 35, 36	Squeegee Asm.	Ref.	Ref.
10	980210	Washer, Impeller	1	1
11	980679	Washer, Spacer, $\frac{3}{16}$ x $1\frac{1}{2}$ x $\frac{1}{8}$	1	1
12	20308A	Adaptor, Motor	1	1
13	85727A	Screw, $\frac{3}{8}$ -16 x 1.0	4	4
15	Page 37	Transaxle Asm.	Ref.	-
	Page 38	Axle Asm.	-	Ref.
16	980638	Washer, Lock, $\frac{3}{8}$	4	4
17	Page 39	Lift Asm., Brush	Ref.	Ref.
18	44809B	Motor, Brush	1	1
19	41601A	Connector	2	2
20	41602A	Housing, Connector	2	2
21	Page 40	Housing Asm., Brush	Ref.	Ref.
22	32403B	Cover, Front	1	1
23	36902A	Pins, Nylon	2	2
25	80256A	Rivet, Plastic Anchor	1	1
26	80255A	Washer, Nylon	1	1
27	699292	Wire Tie	2	2
28	85518A	Screw	6	6
29	47202A	Suppressor	1	1
30◆	915102	Key, Shaft	1	1
NI	Page 27	Brush or Pad Drivers	1	1
NI	41211A	Cable Asm., Battery	1	1
NI	41206A	Cable Series	1	1
NI	38720A	Spacer, Battery Front	1	1
NI	38721A	Spacer, Battery Side	1	1

NOTE: For battery placement and connections see page 10.

NOTE: ◆ indicates a change has been made since the last publication of this manual.

Clarke®
Encore S20/L20
Recovery Tank Assembly Drawing 7/02

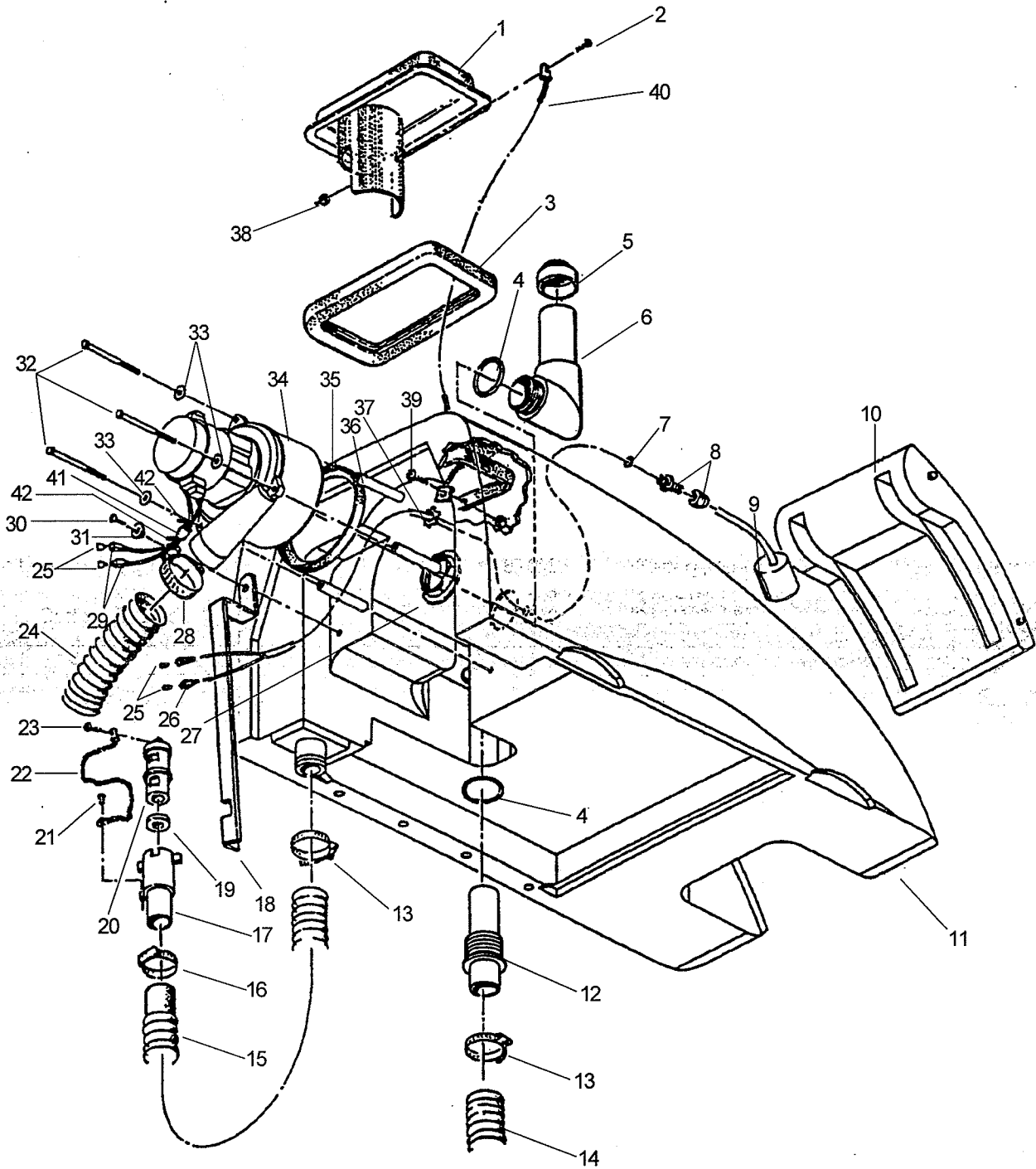

Clarke®
Encore S20/L20
Recovery Tank Assembly Parts List 7/02
Drawing #18114A

Ref #	Part No.	Description	Qty.
1	36209A	Lid	1
2	962798	Screw, 10-24 x ½ Pan	1
3	34256A	Gasket, Lid	1
4	837304	O-Ring	2
5	58069A	Strainer	1
6	39336B	Tube, Stand	1
7	59877A	Seal, Washer	1
8	56459A	Relief, Strain	1
9	10660A	Switch, Float Kit (includes #'s 7,25,26)	1
10	32401B	Lid, Fill, Solution	1
11	30251A	Tank, Recovery	1
12	30132A	Tube, Stand	1
13	752020	Clamp, Hose	2
14	824103	Hose, Squeegee	1
15	30443A	Hose, Drain	1
16	832002	Clamp	1
17	839401	Valve, Drain	1
18	65503A	Latch, Recovery	1
19	833407	Gasket, Drain	1
20	833901	Drain Valve Handle	1
21	962943	Screw, 8-18 x ½ PN	1
22	52206A	Chain	1
23	962987	Screw, 10-24 x ¾ Pan	1
24	674110	Hose	1
25	41809A	Contact	4
26	43402A	Housing, Connector	2
27	920797	Nut	1
28	872010	Clamp, Hose	1
29	43401A	Housing, Vac Motor Connector	2
30	962986	Screw, 5/16-18 x ¾	1
31	87621A	Washer, Shoulder Nylon	1
32	85728A	Screw, ¼-20 x 4 Hex	3
33	87026A	Washer, Flat, ¼	3
34	44917A	Motor, Vac	1
35	643418	Gasket	1
36	58533A	Spacer	3
37	82100A	Nut, Lock	1
38	81110A	Nut, 10-24 ESNA	1
39	85519A	Screw	1
40	692409	Chain, Cover	1
41	47202A	Suppressor	1
42	699202	Wire Tie	2
NI	839410	Valve Asm. (includes Item#17,19, 20, 21, 22)	1

Clarke® Encore S20/L20
Solution Tank Assembly Drawing 8/04

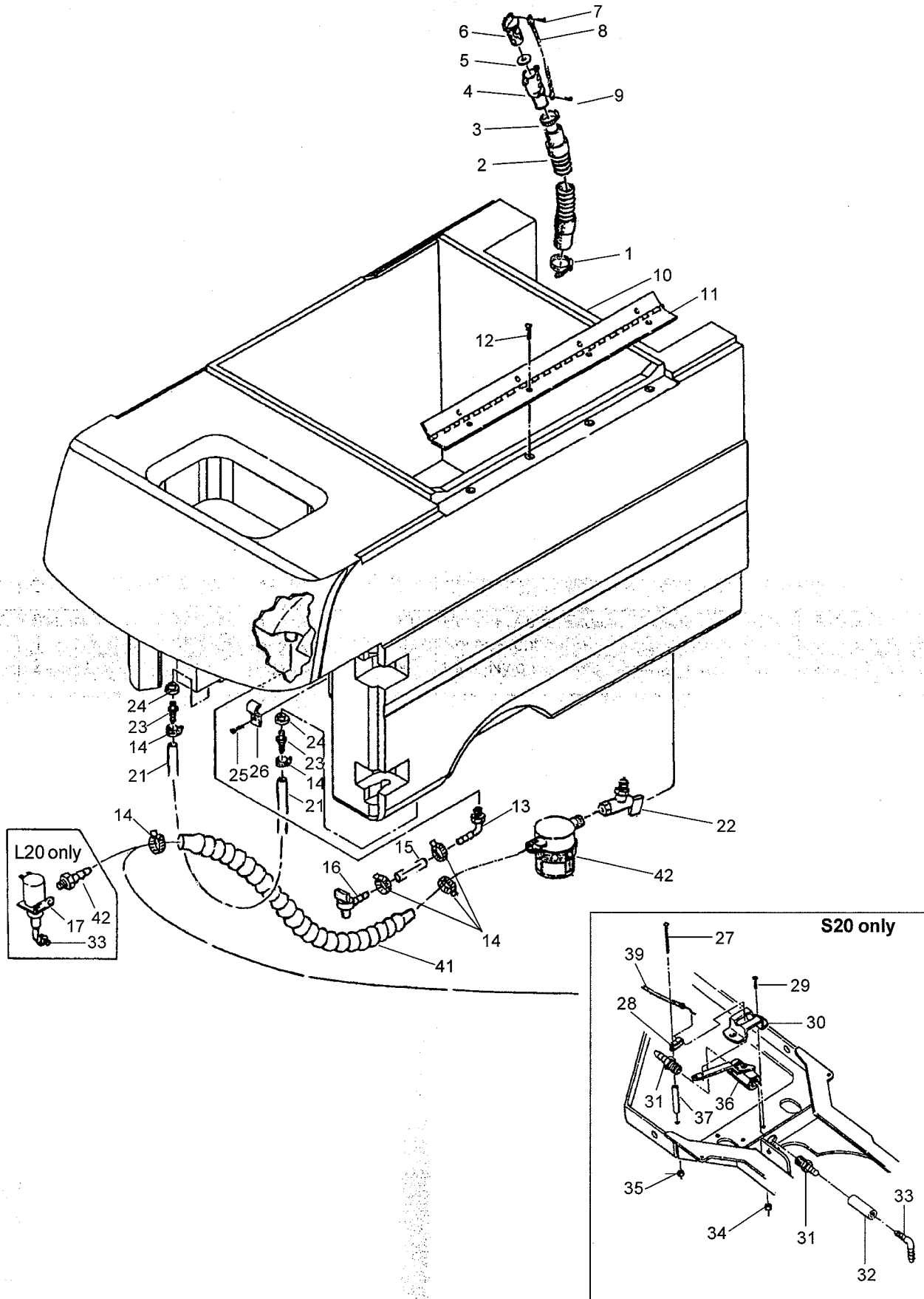

Clarke®
Encore S20/L20
Solution Tank Assembly Parts List 8/04

Ref #	Part No.	Description	L20	S20
1	752020	Clamp	1	1
2	30442A	Hose, Drain	1	1
3	832002	Clamp	1	1
4	839401	Valve, Drain	1	1
5	833407	Gasket, Drain	1	1
6	833901	Drain Valve Handle	1	1
7	962987	Screw, 10-24 x 3/8	1	1
8	52206A	Chain	1	1
9	962943	Screw, 8-18 x 1/2 PN	1	1
10	30250A	Tank, Solution	1	1
11	64517A	Hinge, Solution/Recovery	1	1
12	85398A	Screw, 1/4-20 x 5/8	4	4
13	55162A	Hosebarb	1	1
14	50248A	Clamp, Hose	6	6
15	39335A	Hose, 17'	1	1
16	59612A	Valve, Drain, Battery	1	1
17	59610A	Valve, Flow, Electric	1	-
21	30172A	Hose, Braided, .375 ID x 16 1/2"	1	1
22	51204A	Valve, Solution	1	1
23	52414A	Connector Straight Hose/Tank	2	2
24	51518A	Bushing	2	2
25	84237A	Screw, 10-32 x 1/2	1	1
26	782002	Clamp	1	1
27	85702A	Screw, 1/4-20 x 1 3/4	-	1
28	832102	Clamp	-	1
29	962798	Screw 10-24-1/2	-	2
30	820823	Bracket	-	1
31	53618A	3/8 x 3/8 NPT Hosebarb	-	2
32	39337A	Hose 2 1/2"	-	1
33	51526A	Hosebarb, Elbow	-	1
34	81110A	Nut, 10-24	-	2
35	81104A	Nut, 1/4-20 ESNA	-	1
36	849401	Valve	-	1
37	678215	Spacer	-	1
38	53619A	3/8 x 1/4 NPT Hosebarb	1	-
39	11703A	Solution Cable	-	ref.
41	35138A	Hose, Solution	1	1
42	53562A	Filter, Bowl	1	1
NI	839410	Valve Asm.	-	-
NI	39332A	(includes Item #4, 5, 6, 8, 9) Bulk 100 ft. of hose per P/N 39335A and 39337A		
NI	50389A	Plunger	-	-
NI	50390A	Spring	-	-
NI	50391A	Diaphragm	-	-

53562A Components		
Clarke P/N	Description	Qty.
50081A	Bowl, Filter	1
53563A	Filter, Screen	1
53564A	Upper Body	1
54369A	Gasket, Bowl	1

Clarke® Encore S20/L20
Squeegee Lift Assembly Drawing and Parts List 10/03
Drawing # 18814A

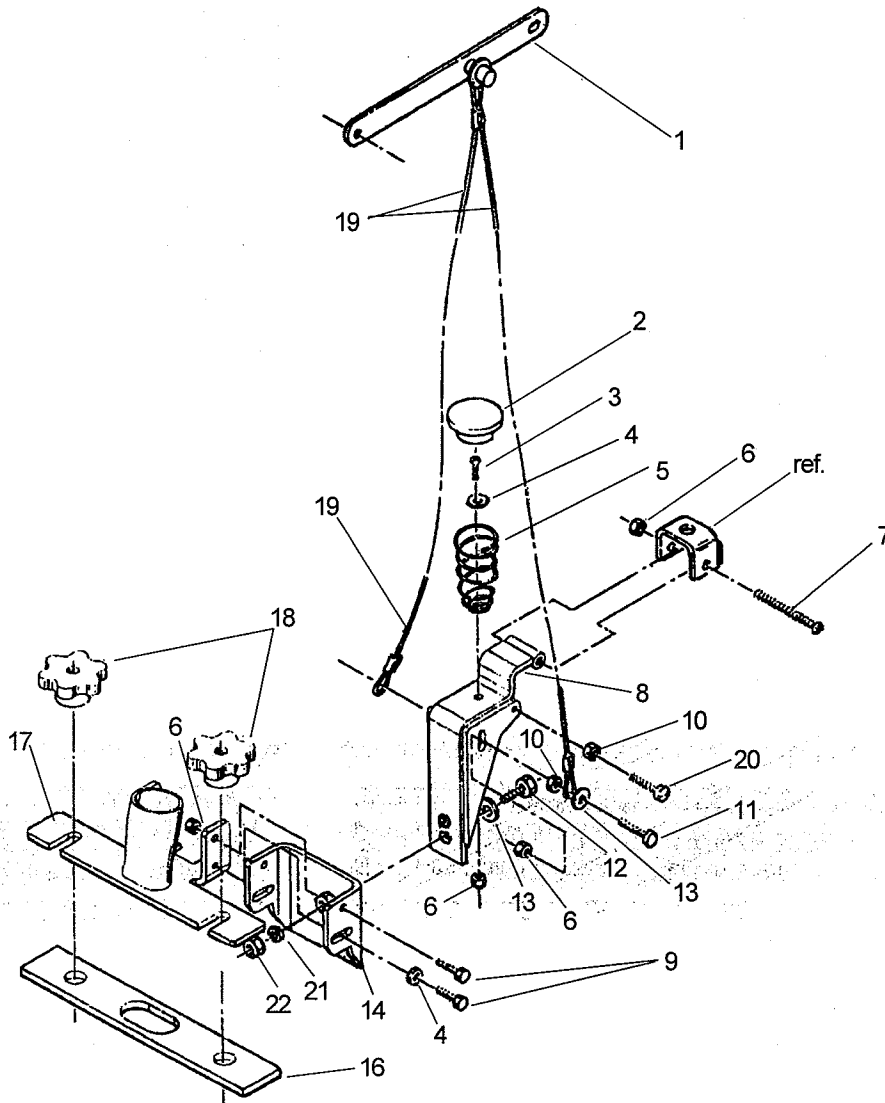

Ref #	Part No.	Description	Qty.
1	ref.21,pg56,65	Handle	-
2	30517A	Bushing	1
3	85600A	Screw, 1/4-20 x 3/4	1
4	87026A	Washer, 1/4, SS	3
5	50034A	Spring, Squeegee	1
6	81104A	Nut, Nylock, 1/4	6
7	85396A	Screw, 1/4-20 x 2 SS	1
8	60225A	Swivel, Squeegee	1
9	170915	Screw, 1/4-20 x 3/4	4
10	920208	Nut, 1/4-20, Plated	4
11	962481	Screw, 1/4-20 x 1 1/4 Hex	2
12	85730A	Screw, 3/8-16, Hex	1
13	87031A	Washer, Flat, 3/8, SS	3
14	69860B	Pin, Bracket Weldment	1
16	34260B	Gasket, Squeegee	Ref.
17	61263A	Bracket, Tube	1
18	25201A	Knob, Clamping	Ref.
19	61677A	Cable, Lift, Squeegee	-
20	86408A	Screw, 1/4-20x1 Truss	2
21	980638	Lockwasher, 3/8 LT Spring Type	1
22	81111A	Nut, 3/8-16 ESNA	1

Clarke® Encore S20/L20
Squeegee Assembly Drawing and Parts List 8/04
29" Asm. - 18820A (Optional)
33" Asm. - 18821A (discontinued, use 10129A)

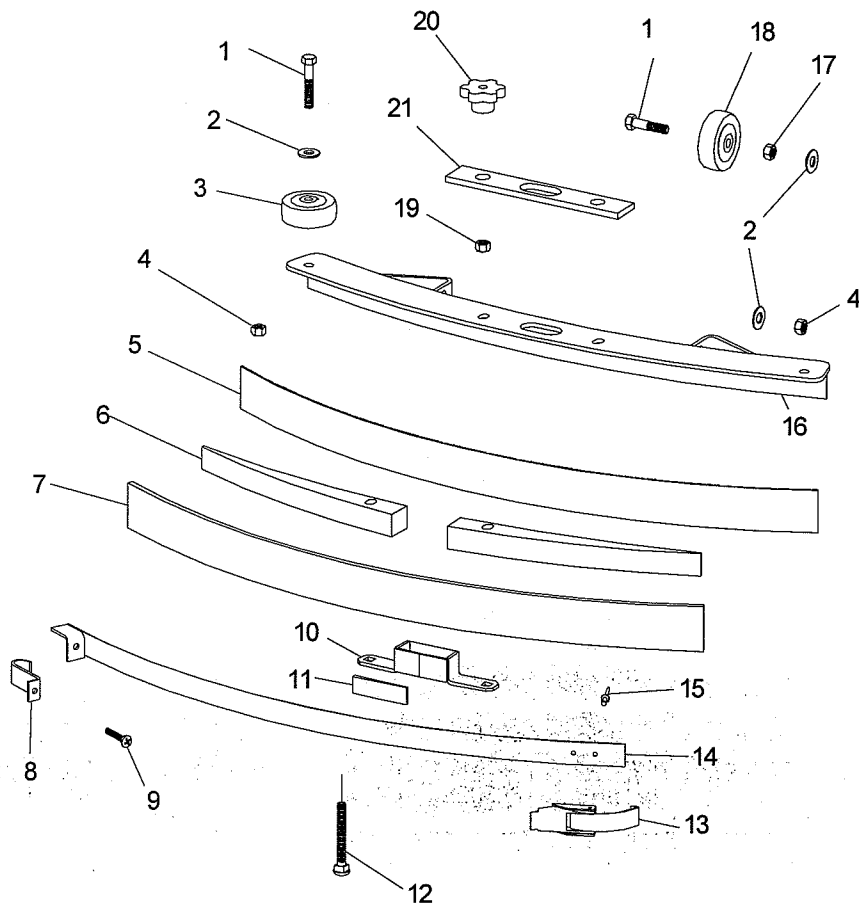

Ref #	Part No.	Description	29"	33"
1	962522	Screw, 3/8-16 x 2" Hex	4	4
2	980687	Washer, 15/32 I.D. x 15/16 O.D.	6	6
3	59950A	Wheel, Guide	2	2
4	81111A	Nut, 3/8-16 ESNA	4	4
5	30950A	Blade, Ribbed, Urethane	-	1
	30951A	Blade, Ribbed, Urethane	1	-
6	38713A	Spacer, 29"	2	-
	38719A	Spacer, 33"	-	2
7	30931A	Blade, Rubber, Outer	1	-
	30946A	Blade, Rubber, Outer	-	1
8	62421A	Clamp, End	1	1
9	86004A	Screw, 1/4-20 x 1 1/2 Hex	1	1
10	62712A	Duct, Squeegee Inlet	1	1
11	37016A	Pad, Squeegee Grip	1	1
12	80011A	Screw, 3/8-16 x 3 CR S.S.	2	2
13	55722A	Latch, Squeegee Strap	1	1
14	62441A	Clamp, Squeegee 29"	1	-
	62445A	Clamp, Squeegee 33"	-	1
15	170932	Rivet, Pop 3.16 S.S. 1/8"	2	2
16	69059A	Squeegee Weldment 29"	1	-
	69672A	Squeegee Weldment 33"	-	1
17	81207A	Nut, 3/8-16 S.S.	2	2
18	419702	Wheel	2	2
19	81301A	Nut, 3/8-16 Jam S. S.	2	2
20	25201A	Knob	Ref	Ref
21	34260B	Gasket	Ref	Ref

Optional:

- NI 30938A Nitrile 29" Outer Blade
- NI 30949A Nitrile 33" Outer Blade
- NI 30930A Rubber 29" Inner Blade
- NI 30947A Rubber 33" Inner Blade

NOTE:

When changing blades loosen nuts #19. Clamp blades on squeegee. Retighten #19 nuts. This will allow spacer #6 to readjust to different blade thickness.

Clarke®
Encore S20/L20
Squeegee Assembly Drawing 6/04
Drawing # 10068A and 10129A (used on machines built after 4-8-03, starting with Serial #AC2077)

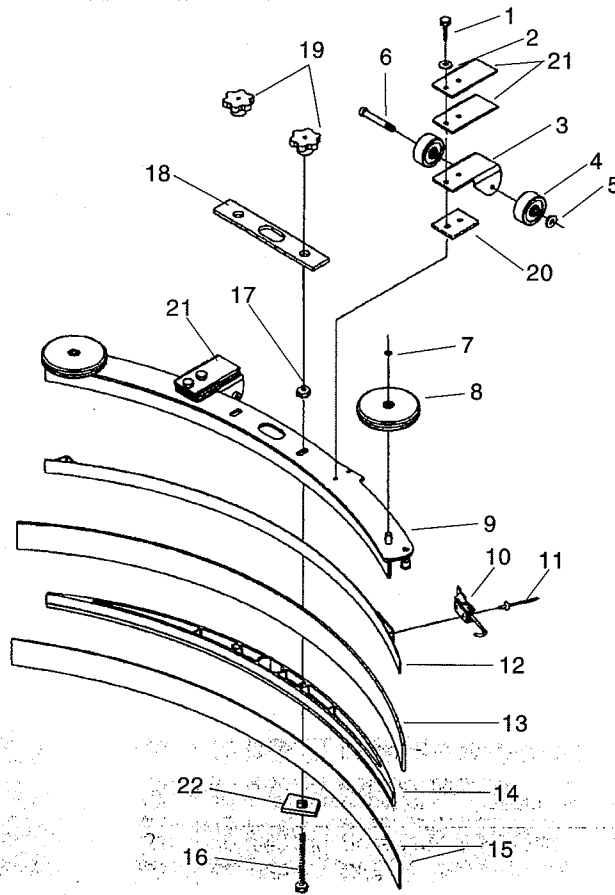

Ref. #	Part No.	Description		
			10068A	10129A
			39" Qty	32" Qty
1	80252A	Screw, 1/4-20 x 1 Hex SS	-	4
	80253A	Screw, 1/4-20 x 1 1/2 Hex SS	4	-
2	980657	Washer, 1/4 Lock	4	4
3	60243A	Bracket, Squeegee Wheel	2	2
4	30049B	Wheel, Squeegee	4	4
5	81104A	Nut, 1/4-20	2	2
6	60254A	Bolt, Shoulder 5/16 x 2 1/4	2	2
7	50958A	Ring, 3/8 ID Snap	2	2
8	30048A	Wheel, Guide, 4 Inch Diameter	2	2
9	60272A	Channel, Squeegee Weldment 39"	1	-
	60234A	Channel, Squeegee Weldment 32"	-	1
10	50835A	Latch, Squeegee Clamp	1	1
11	930086	Rivet, 3/16 x .450 Aluminum	2	2
12	60252A	Strap, Clamp, Squeegee Retainer 39"	1	-
	60232A	Strap, Clamp, Squeegee Retainer 32"	-	1
13	30069A	Blade, Rear, Gum Rubber, 39"	1	-
	30067A	Blade, Rear, Gum Rubber, 32"	-	1
14	30058A	Spacer, Squeegee 39"	1	-
	30047A	Spacer, Squeegee 32"	-	1
15	30091A	Blade, Front Ribbed 39"	1	-
	30066A	Blade, Front Ribbed 32"	-	1
16	80011A	Screw, 3/8-16 x 3	2	2
17	81301A	Nut, 3/8-16 Jam SS	2	2
18	34260B	Gasket	1	1
19	25201A	Knob	2	2
20	60358A	Shim, Squeegee Wheel	2	2
21	61370A	Weight	8	4
22	80280A	Nut, Squeegee Backup	2	2

Clarke® Encore L20
Frame Transaxle Assembly Drawing and Parts List 8/04

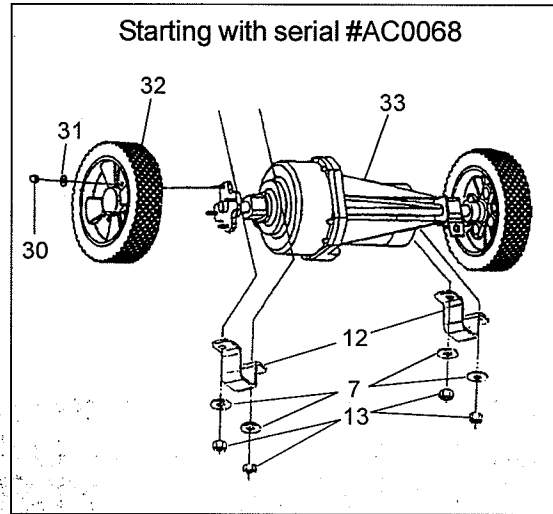
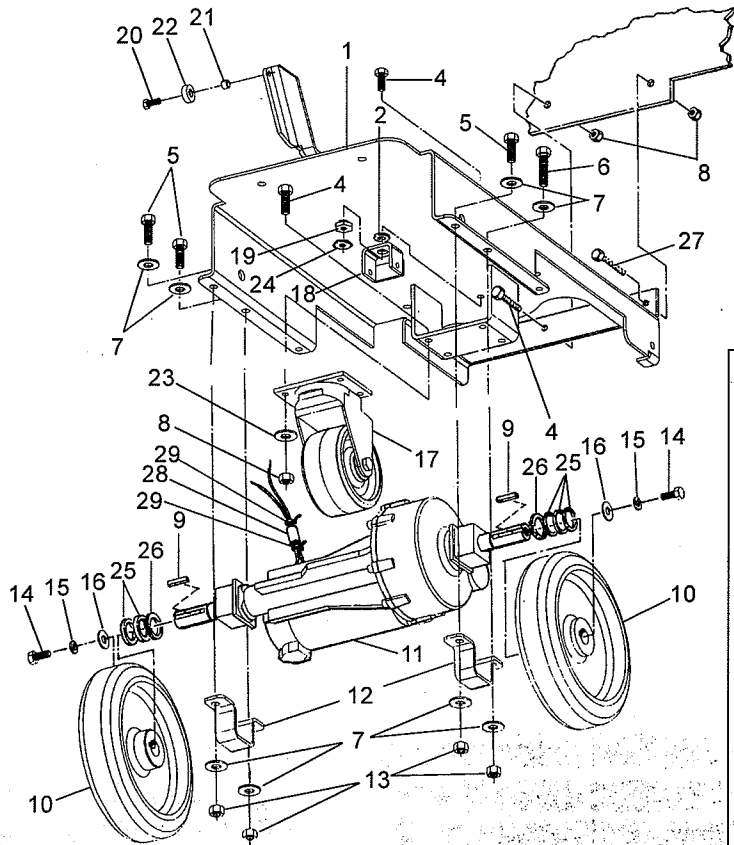

Ref #	Part No.	Description	Qty.
1	63431A	Frame	1
2	87607A	Washer, Nylon	1
4	85811A	Screw, $\frac{5}{16}$ -18 x $\frac{3}{4}$	7
5	85727A	Screw, $\frac{3}{8}$ -16 x 1	3
6	85836A	Screw, $\frac{3}{8}$ -16 x 2	1
7	87031A	Washer, Flat, $\frac{3}{8}$, SS	8
8	920110	Nut, $\frac{5}{16}$ -18 ESNA	7
9	915044	Key, $\frac{3}{16}$ X $\frac{3}{16}$ X 1	2
10	69204B	Wheel, Traverse (Grooved)	2
	69204A	Wheel, Traverse (Smooth)opt.	2
11*	10380A	Transaxle (incl 30, 31, 32, 33)	1
12	62435A	Clamp, Transaxle	2
13	81105A	Nut, $\frac{3}{8}$ -16 ESNA	4
14	962620	Screw, Hex, $\frac{5}{16}$ -24 x $\frac{3}{4}$	2
15	980652	Washer, Lock, $\frac{5}{16}$	2
16	980205	Washer	2

Ref #	Part No.	Description	Qty.
17	61675A	Caster	1
18	61252A	Bracket, Squeegee	1
19	61433A	Nut, Spacer	1
20	85391A	Screw, $\frac{1}{4}$ -20 x $\frac{5}{8}$	1
21	608210	Spacer, Bolt	1
22	51516A	Bushing	1
23	980651	Washer, Flat, Plated, $\frac{5}{16}$	4
24	81112A	Nut, $\frac{5}{16}$ ESNA Thin SS	1
25	87616A	Washer	5
26	57423A	Ring, Retainer	2
27	85814A	Screw, $\frac{5}{16}$ -18 x $1\frac{1}{4}$	1
28	47202A	Suppressor	1
29	699202	Wire Tie	2
30	81217A	Nut, $\frac{1}{4}$ -20 S.S. Thin	8
31	87026A	Washer, Flat $\frac{1}{4}$ S.S.	8
32	61437A	Wheel Assembly	2
33	52827A	Transaxle (after serial #AC0068)	1

NOTE: *69165A Transaxle Assembly has been cross-referenced to 10380A but service parts are still available

Transaxle P/N			
Qty	Description	*69165A	52827A
1	Motor, Transaxle	45044A	40579A
1	Coupler, Motor Drive	52660A	50983A
1	Gear Box and Assembly	69189A	40577A
1	Brush Asm., Comm End	52940A	40578A
2	Sleeve, Elastomeric	51202A	51056A
2	Flange, Wheel Kit		10135A

Clarke®
Encore S20
Frame Assembly Drawing and Parts List 8/04

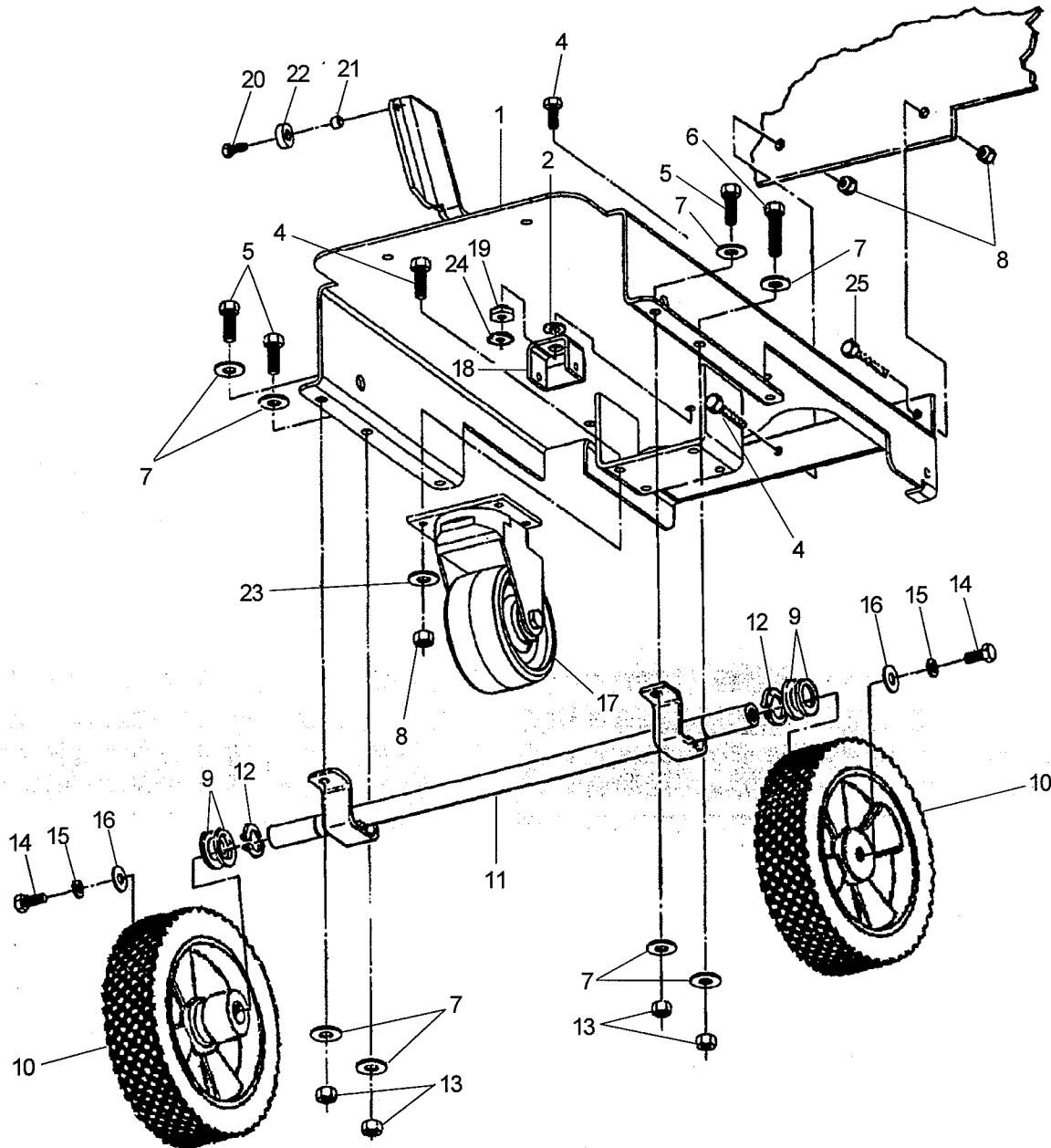

Ref #	Part No.	Description	Qty.
1	63431A	Frame Weldment	1
2	87607A	Washer, Nylon	1
4	85811A	Screw, $\frac{5}{16}$ -18 x $\frac{3}{4}$	7
5	85727A	Screw, $\frac{3}{8}$ -16 x 1	3
6	85836A	Screw, $\frac{3}{8}$ -16 x 2	1
7	87031A	Washer, Flat, $\frac{3}{8}$, SS	8
8	920110	Nut, $\frac{5}{16}$ -18 ESNA	7
9	87616A	Washer	4
10	61436B*	Wheel, Non-Traverse	2
11	60535A	Axle, Non-Traverse	1
12	57423A	Ring, Retainer	2

* Used on machines built after 8/26/04 starting with serial #BHXXXX

Ref #	Part No.	Description	Qty.
13	81105A	Nut, $\frac{3}{8}$ -16 ESNA	4
14	962620	Screw, Hex, $\frac{5}{16}$ -24 x $\frac{3}{4}$	2
15	980652	Washer, Lock, $\frac{5}{16}$	2
16	980205	Washer	2
17	61675A	Caster	1
18	61252A	Bracket, Squeegee	1
19	61433A	Nut, Spacer	1
20	85391A	Screw, $\frac{1}{4}$ -20 x $\frac{5}{8}$	1
21	608210	Spacer, Bolt	1
22	51516A	Bushing	1
23	980651	Washer, Flat, Plated, $\frac{5}{16}$	4
24	81112A	Nut, $\frac{5}{16}$ ESNA Thin SS	1
25	85814A	Screw, $\frac{5}{16}$ -18 x $1\frac{1}{4}$	1

Clarke®
Encore S20/L20
Brush Lift Assembly Drawing and Parts List 2/04
Drawing #11446A

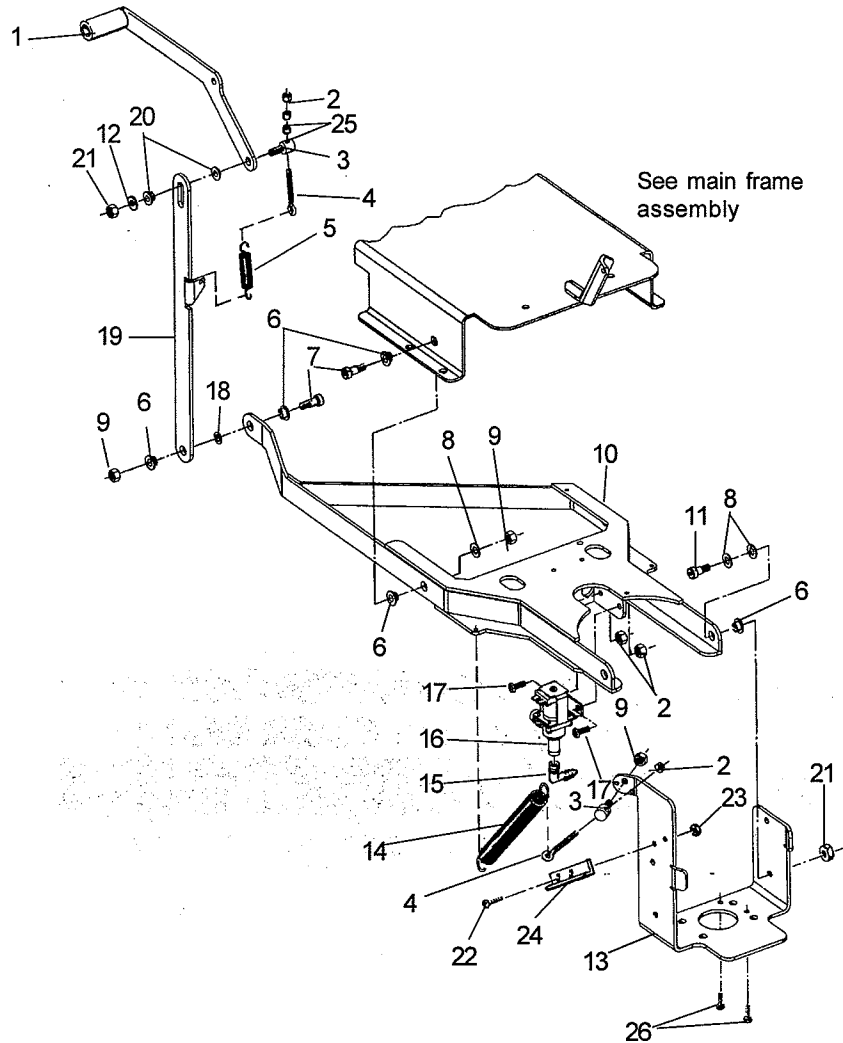

Ref #	Part No.	Description	Qty.
1	ref 37, pg 57, 65	Handle, Lift, Brush	-
2	81104A	Nut, 1/4-20 ESNA	4
3	848508	Swivel, Rod, Brake	2
4	80042A	Screw, Eye, Adjustment	2
5	58691A	Spring, Pressure, Sander	1
6	87620A	Washer, Shoulder,	8
7	80041A	Bolt, Shoulder, 3/8 x 1/2	3
8	87618A	Washer	6
9	920181	Nut, 5/16, ESNA	4
10	63432A	Frame, Brush Lift	1
11	80040A	Bolt, Shoulder, 3/8 x 3/8	2
12	980692	Washer	1

Ref #	Part No.	Description	Qty.
13	69861A	Bracket, Motor, Brush	1
14	56493A	Spring	1
15	1551526A	Hosebarb	1
16	59610A	Valve, Solution	Ref
17	85391A	Screw, 1/4-20 x	2
18	87619A	Washer, 375032	1
19	60207A	Link, Brush Lift	1
20	87621A	Washer, 3001	2
21	81112A	Nut, 5/16-18 Thin ESNA SS	3
22	962798	Screw 10-24 x 1/2	2
23	81110A	Nut 10-24	2
24	64239A	Plate, Deflector	1
25	608210	Spacers (optional)	
26	962554	Screw	2

Clarke®
Encore S20/L20
Brush Housing Assembly Drawing and Parts List 7/02
Drawing # 11447A

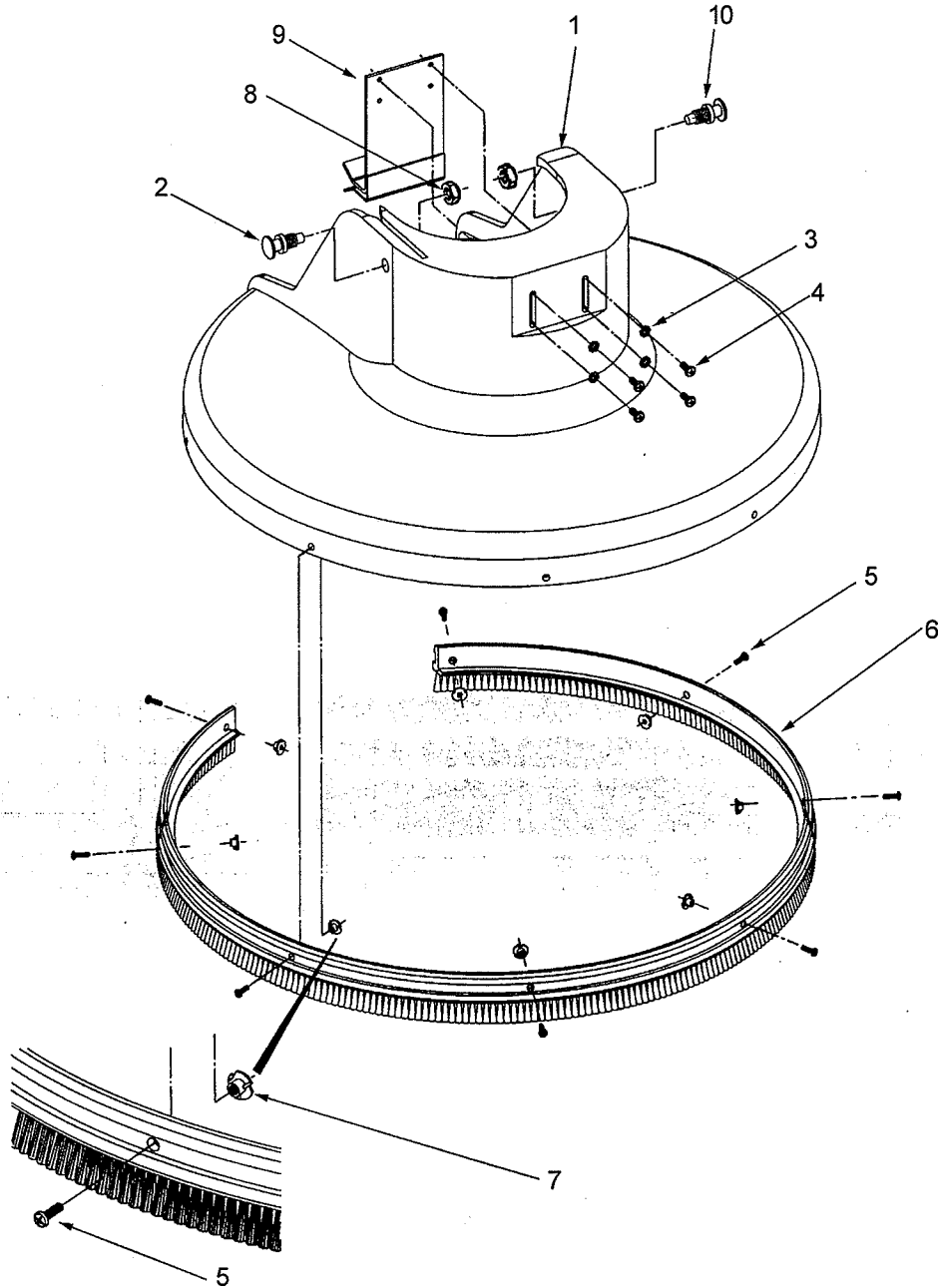

Ref #	Part No.	Description	Qty.
1	30255A	Housing, Brush	1
2	636706	Pin	1
3	980603	Washer	4
4	962798	Screw, 10-24 x ½	4
5	84237A	Screw, 10-32 x ½	8
6	38241A	Skirt, Fibers	1
7	82004A	Nut, 10-32 "T"	8
8	920078	Nut, ½-20 S.S. Jam	2
9	62438A	Bracket, Stop, Housing, Brush	1
10	66550A	Pin	1

Clarke® Encore L20
Transaxle Repair Parts 7/02

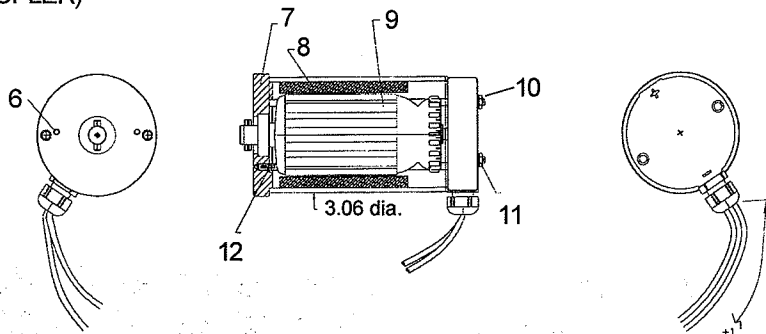
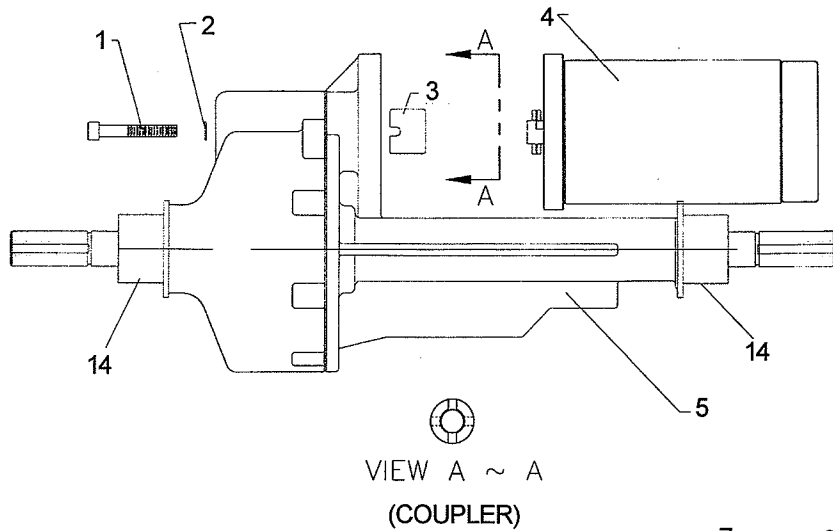

Ref #	Part No.	Description	Qty.
1		Screw, ¼-20	-
2		Washer, ¼ Lock	-
3	52660A	Coupler	1
4	45044A	Motor	1
5	69189A	Transaxle Gearbox Assembly	1
6		Pin, Dowel	-
7		End Plate, Output	-
8		Magnet and Housing Assembly	-
9		Armature and Bearing Assembly	-
10		Washer, #10 Lock	-
11		Nut 10-32	-
12		Stud	-
13	52940A	Commutator End Bell & Brush Asm.	1
14	51202A	Mount, Bushing	2

Torque #1 80 inch pounds
Torque #11 40-45 inch pound tooth nuts
#12 Loctite #262

NOTE: Transaxle unit is sealed. No lubrication required

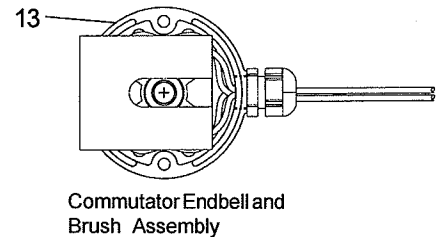

Installation Instructions:

1. With motor still fastened to transaxle gearbox, remove old endbell by backing off the two 10-32 nuts and removing the lock washers. Slide endbell off motor.
2. Assemble new commutator endbell and brush assembly by sliding it over shaft and motor studs until brush retaining clip bottoms out. Holding endbell still, slide retaining clip out from between the brushes and commutator. Push the endbell on the rest of the way until endbell casting bottoms on the motor frame. Replace the lock washers and nuts and torque the nuts 40-45 in.-lbs.

Clarke®
Encore S20/L20
Transaxle Drawing & Parts List 2/03
52827A

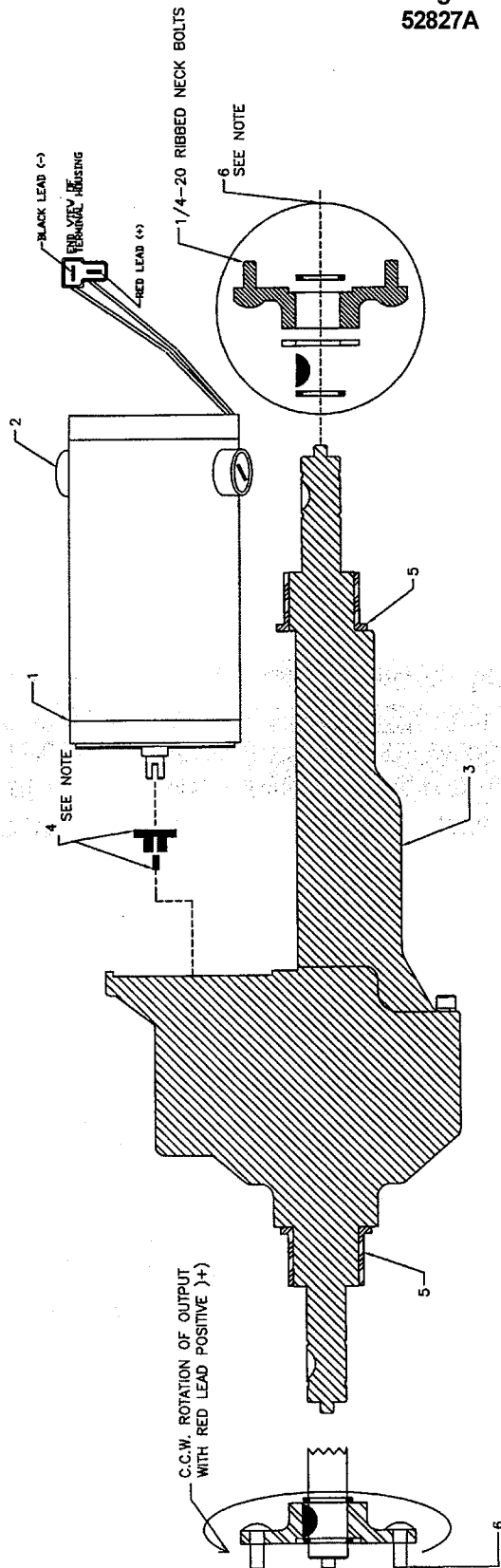

- NOTE:**
- ITEM #4** INCLUDES THE FOLLOWING PARTS:
 (1) MOTOR COUPLER
 (1) MOTOR KEY
- ITEM #6** INCLUDES THE FOLLOWING PARTS:
 (2) SNAP RINGS
 (1) MCGURUFF KEY
 (1) WHEEL FLANGE
 (4) 1/4-20 X .1 LONG RIBBED CARRIAGE BOLTS
 (1) 0.010" THICK SHIM

REF. #	CLARKE P/N	DESCRIPTION	QTY
6	10135A	WHEEL HUB KIT	2
5	51056A	MOUNT BUSHING	2
4	50983A	COUPLER, TRANSAXLE	1
3	40577A	GEARBOX ASM., TRANSAXLE	1
2	40578A	BRUSH ASM., COM. END	1
1	40579A	MOTOR, TRANSAXLE	1
		CLARKE P/N	DESCRIPTION
			QTY

Clarke®
Encore S20/L20
Brush Motor Drawing & Parts List 7/02
Motor Asm. 44809B

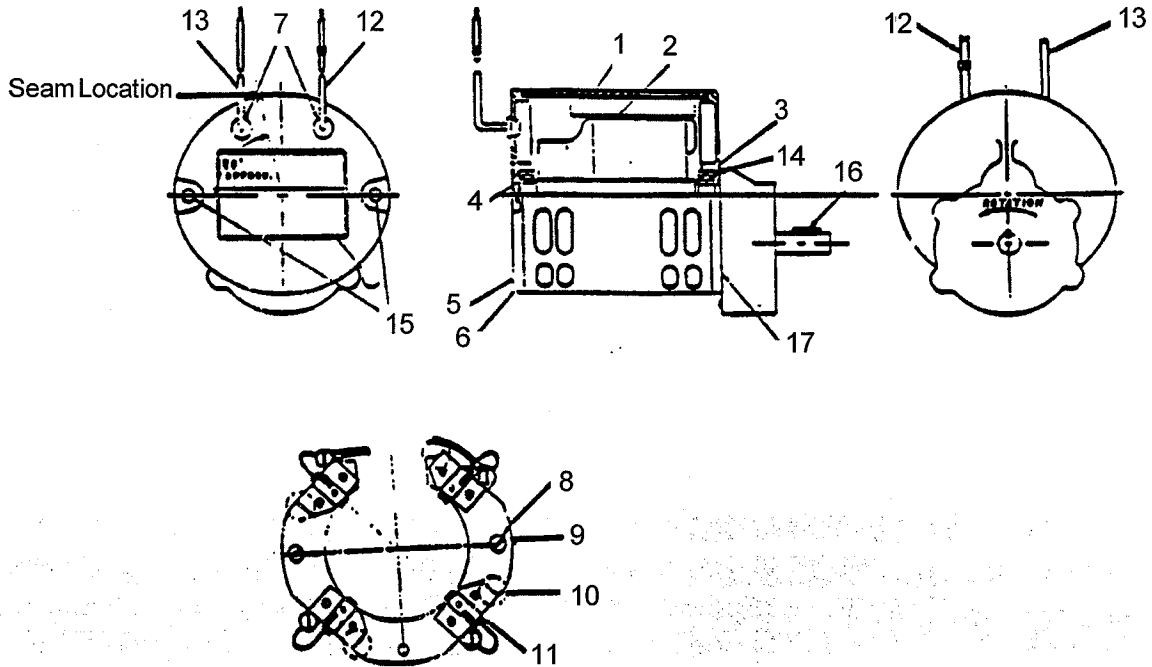

Item	Part No.	Description	Qty
1	56478A	Stator Frame Assembly (w/Magnets & Clips)	1
2	50142A	Armature Assembly (w. B.E. & F.E. Bearings)	1
3	902654	Bearings B.E.	1
4	902550	Bearing F.E.	1
* 5		Commutator Bracket Assembly (w/Brush BRD Assembly Leads)	1
6	50520A	Commutator Bracket	1
7	56480A	Strain Relief	2
8	962546	Brush Board Screw	2
9	50517A	Brush Board Assembly (w/ Springs & Brushes)	1
10	448396	Brush Spring	4
11	40826A	Brush Assembly	4
12	55657A	Lead Assembly	1
13	55656A	Lead Assembly	1
* 14		Helical Washer	1
15	50515A	Thru Bolt	2
16	80501A	Shaft Key	1
17	54238A	B.E. Bracket Assembly (Gear Box)	1

* NOTE: Parts not available at this time.

Clarke®
Encore S20/L20
Gearbox Assembly Drawing and Parts List 7/02
Form #54238A

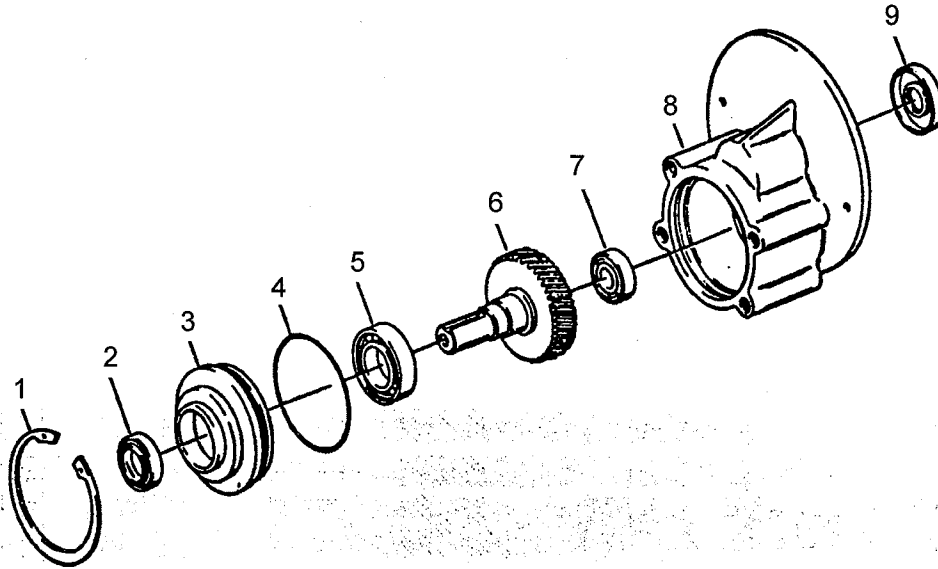

Ref #	Part No.	Description	Qty
1	57846A	Ring, Snap	1
2	507641	Seal, Oil, Small	1
3	52050A	Cap End	1
4	56668A	O-Ring	1
5	51176a	Bearing, Large	1
6	58316A	Shaft & Gear	1
7	902605	Bearing, Small	1
8	54883A	Housing	1
9	58144A	Seal, Oil Large	1
10	NI	Darina EP2 Grease	4 oz.

Clarke® Encore S20/L20
 Vacuum Motor Model
 Drawing 7/02
 Form # 44917A

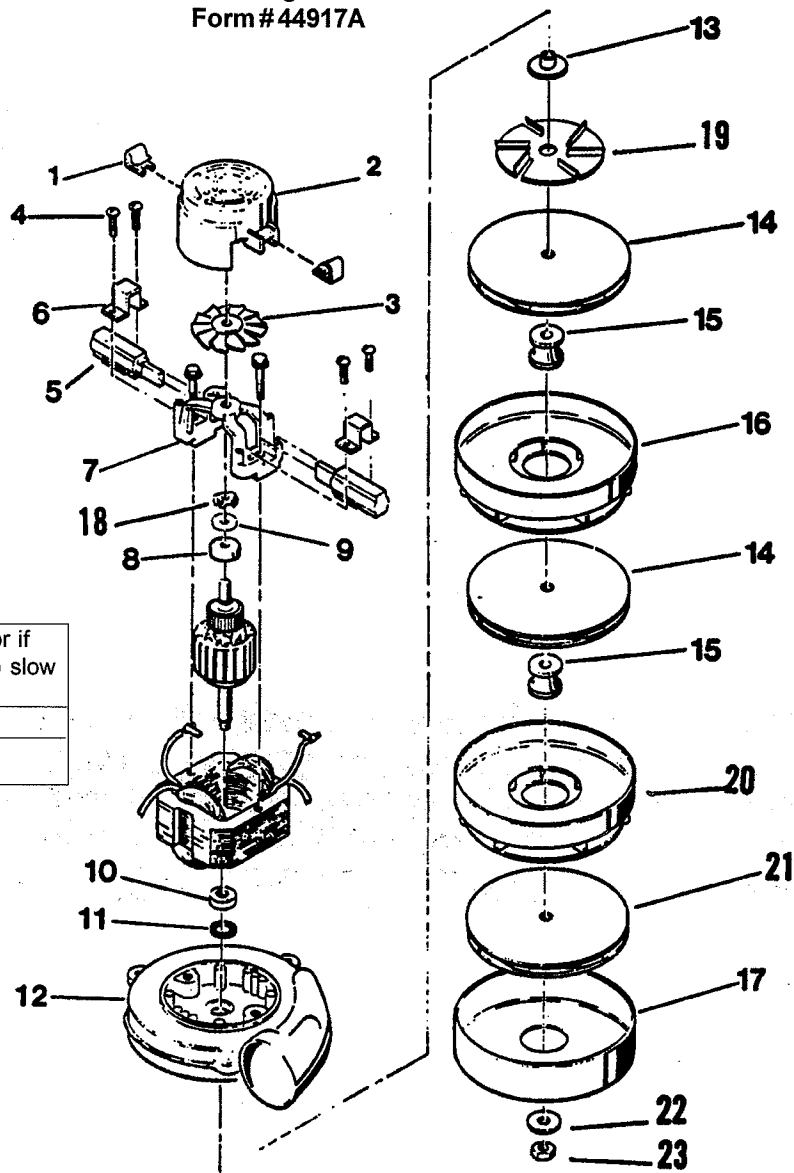

* Recommended Brush Replacement

1 st	Replace at 800 hours or if vacuum motor runs too slow to pick up water
2 nd	50% of 1 st
3 rd	33% of 1 st

Ref #	Part No.	Description	Qty
* 1		Clip (optional)	2
2	54809A	Housing Vent	1
3		Fan	1
4	85303A	Screw - 8x32 - 3/8 P.N.	4
5	40817A	Brush, Mechanism	2
* 6		Clamp	2
7	50618A	Bracket, Commutator End	1
8		Bearing	1
9	672714	Disc	1
10		Bearing	1
11	59803A	Washer, Neoprene	1
12		Bracket, Fan End	1
* 13		Spacer	1

Ref #	Part No.	Description	Qty
14	53914A	Fan, Rotating	2
15	658201	Spacer	2
* 16		Fan, Stationary	1
* 17		Shell, Fan	1
* 18		Spring, Load	1
* 19		Fan, Air Seal	1
* 20		Fan, Stationary	1
* 21		Fan, Rotating	1
* 22		Washer	1
* 23		Nut	1

*NOTE: Parts not available at this time.

Clarke®
Encore S20/L20
Battery Charger Drawing and Parts List 7/02

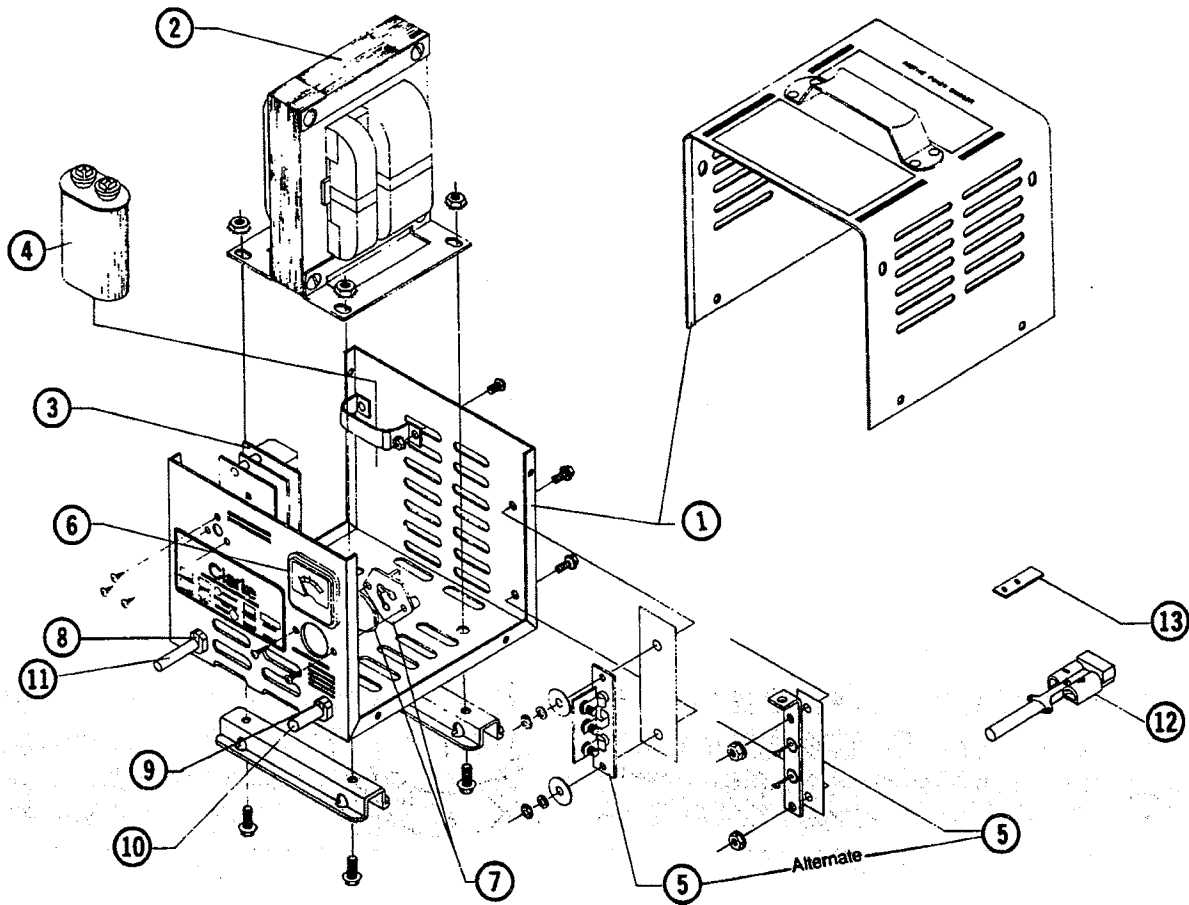

WARNING: All electrical repairs must be performed by qualified personnel only.

Charger #40512A: 24 volt, 25 amp D.C., 115 volt, A.C., 60 Hz.

Charger #40513A: 24 volt, 25 amp D.C., 230 volt, A.C., 50 Hz

Ref. No.	Description	Charger 40512A	Charger 40513A
1	Charger Case	41129A	* —
2	Transformer	* —	48409A
3	Electronic Controller Kit	47500A	48200A
4	Capacitor, 660 V.A.C.	912132	912132
5	Heat Sink Assembly	912212	912212
6	Ammeter	40200A	40200A
7	Fuse Holder	912382	912382
8	Strain Relief, A.C. Cord	* —	* —
9	Strain Relief, D.C. Cord	747553	747553
10	D.C. Cord Assembly	51986A	51986A
11	A.C. Cord Assembly	51974A	908947
12	Housing, Red	911470	* —
13	D.C. Plug Lock Key	795020	795020

* NOTE: Parts not available at this time.

Clarke®
Encore S20/L20
Optional Brake Drawing and Parts List 7/02
Form # 10635A

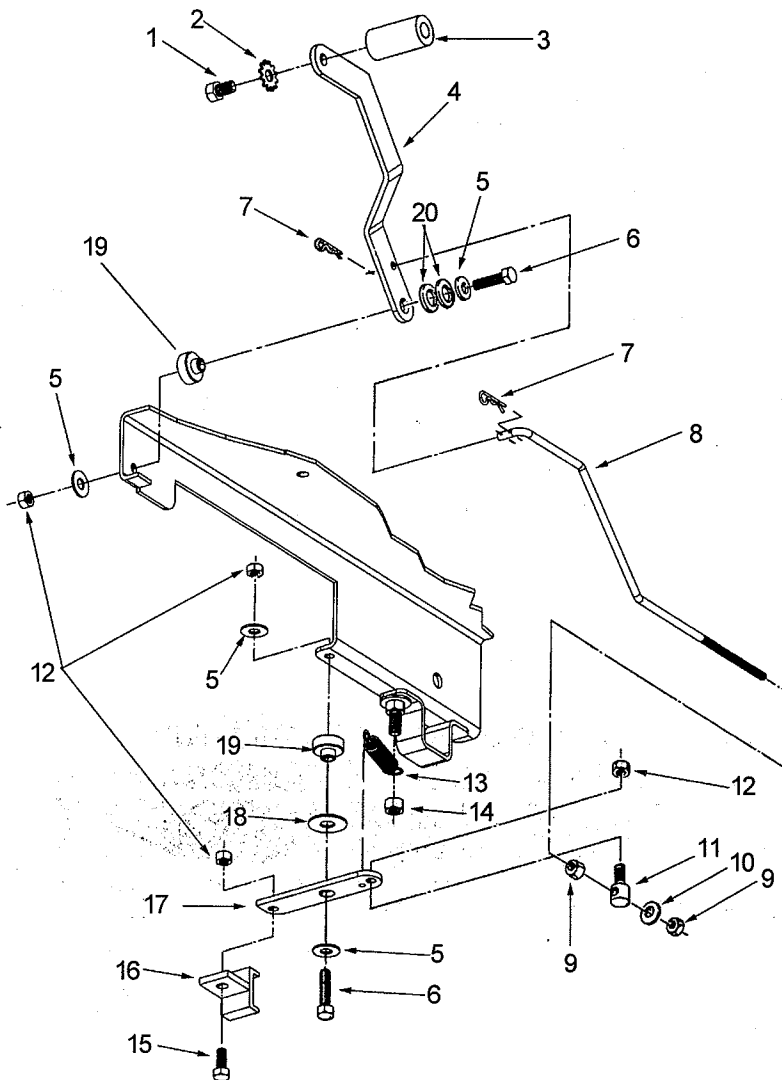

Ref #	Part No.	Description	Qty.
1	85389A	Screw, $\frac{3}{8}$ -16 x $\frac{5}{8}$	1
2	980666	Washer, Starlock, $\frac{3}{8}$	1
3	64490A	Handle	1
4	65627A	Brake, Lever	1
5	980651	Washer, Flat, $\frac{5}{16}$	4
6	85814A	Screw, $\frac{5}{16}$ -18 x $1\frac{1}{4}$	2
7	836711	Clip	2
8	67161A	Rod, Brake	1
9	81104A	Nut, $\frac{1}{4}$ -20 ESNA	2
10	87026A	Washer, Flat, $\frac{1}{4}$	1
11	848508	Swivel, Rod, Brake	1
12	920110	Nut, $\frac{5}{16}$ -18 ESNA	4
13	848302	Spring, Arm, Brake	1
14	81105A	Nut, $\frac{3}{8}$ -16 ESNA	1
15	85811A	Screw, $\frac{5}{16}$ -18 x $\frac{3}{4}$	1
16	66212A	Pad, Brake	1
17	60451A	Bar, Brake	1
18	87607A	Washer, Flat, Nylon, $\frac{1}{2}$	1
19	67877A	Spacer	2
20	980673	Washer	2

Clarke®
Encore S20 Drawing & Parts List
Electronic Solution Valve Kit 10669A 8/04
(this diagram is for models without Solution Shut-Off)

Parts included in Kit:

Ref #	Qty	Part No.	Description
1	1	53619A	Hosebarb, 3/8 x 1/4 NPT (for use on models w/shut-off valve only)
2	1	44308A	Solution Control Module
3	1	51526A	Hosebarb, Elbow
4	1	59610A	Solution Valve
5	2	85391A	Screw 1/4-20
6	2	81104A	Nut, 1/4-20 ESNA
7	1	30131A	Hose, Adapter
8	1	838517	Filter, Screen
NI	1	49776A	Harness, Solution Valve
NI	6	699202	Cable Ties

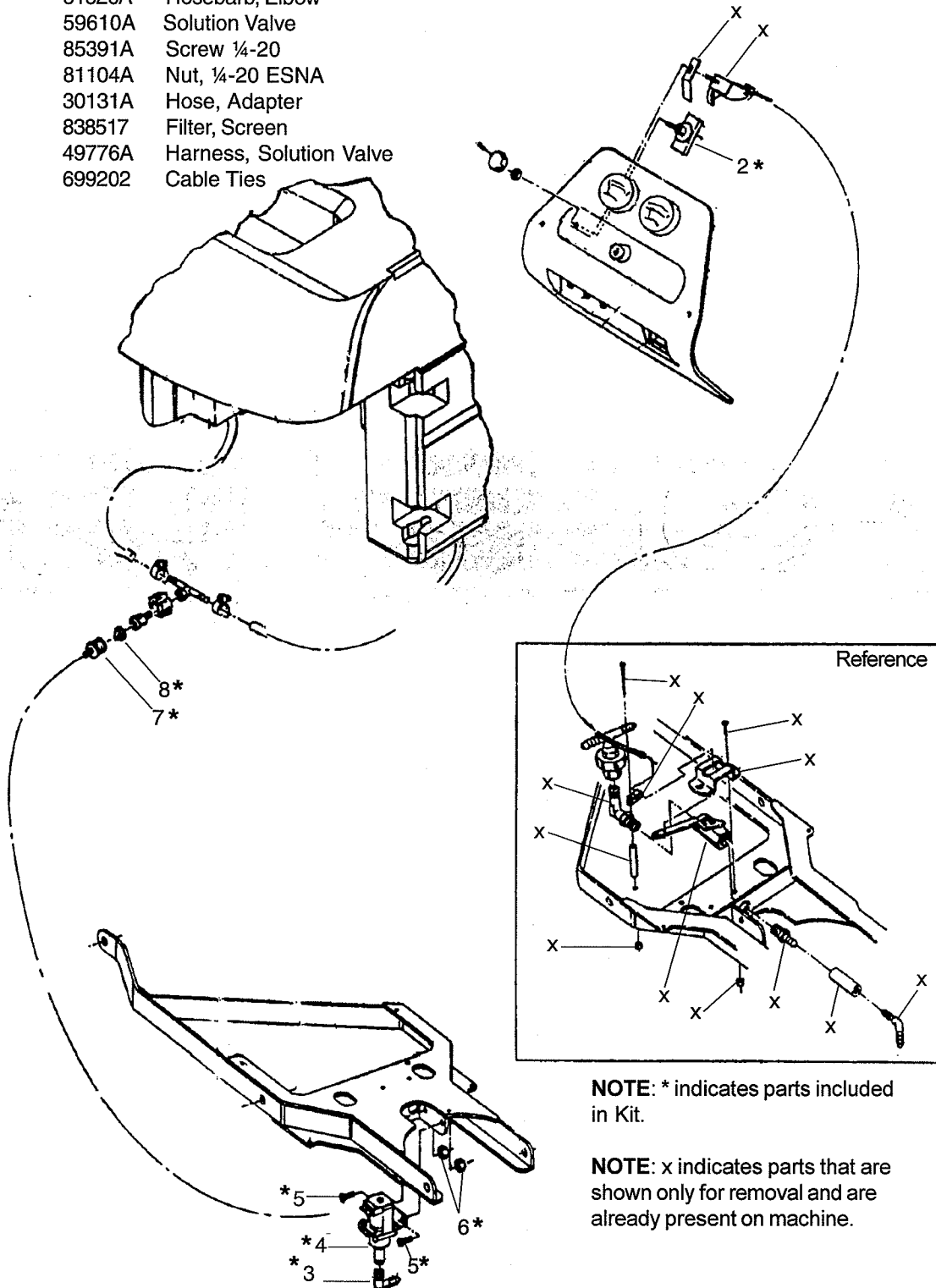

NOTE: * indicates parts included in Kit.

NOTE: x indicates parts that are shown only for removal and are already present on machine.

Clarke®
Encore S20 Drawing & Parts List
Electronic Solution Valve Kit 10669A 8/04
(this diagram is for models with Solution Shut-Off)

Parts included in Kit:

Ref #	Qty	Part No.	Description
1	1	53619A	Hosebarb, 3/8 x 1/4 NPT
2	1	44308A	Solution Control Module
3	1	51526A	Hosebarb, Elbow
4	1	59610A	Solution Valve
5	2	85391A	Screw 1/4-20
6	2	81104A	Nut, 1/4-20 ESNA
7	1	30131A	Hose, Adapter (not used on models w/solution shut-off valve)
8	1	51204A	Valve Solution
9	1	53562A	Filter Bowl
NI	1	49776A	Harness, Solution Valve
NI	6	699202	Cable Ties

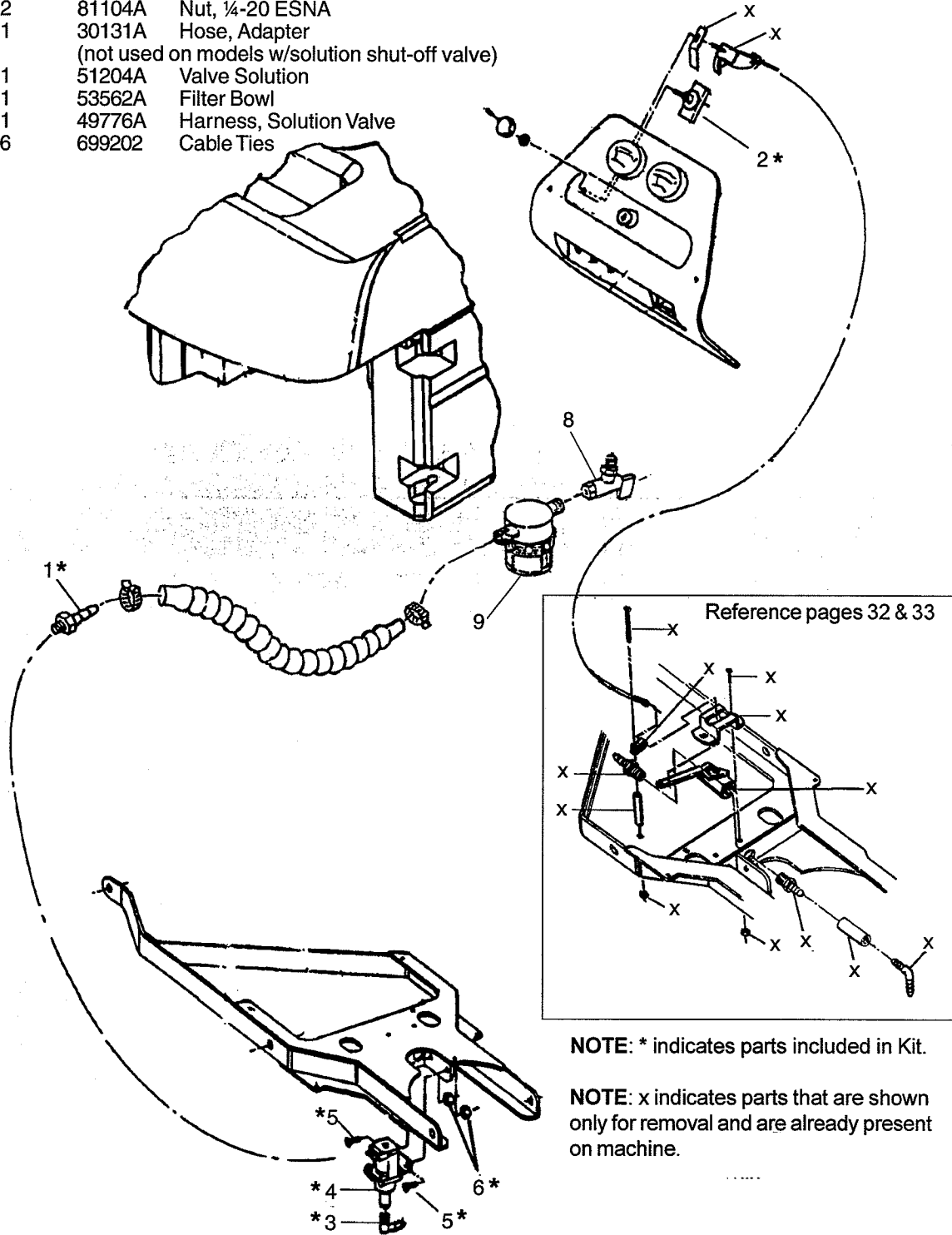

NOTE: * indicates parts included in Kit.

NOTE: x indicates parts that are shown only for removal and are already present on machine.

Clarke®
Encore S20/L20 Drawing & Parts List
ESP Recycle System Kit 10663A 7/02

Tools Needed:

- | | |
|--|---------------------------|
| Adjustable wrench | 3/8" diameter drill bit |
| Short or right angle Phillips® screwdriver | 7/16" diameter drill bit |
| Wire strippers | 15/32" diameter drill bit |
| Wire terminal crimpers | 7/8" diameter drill bit |
| Drill motor | |

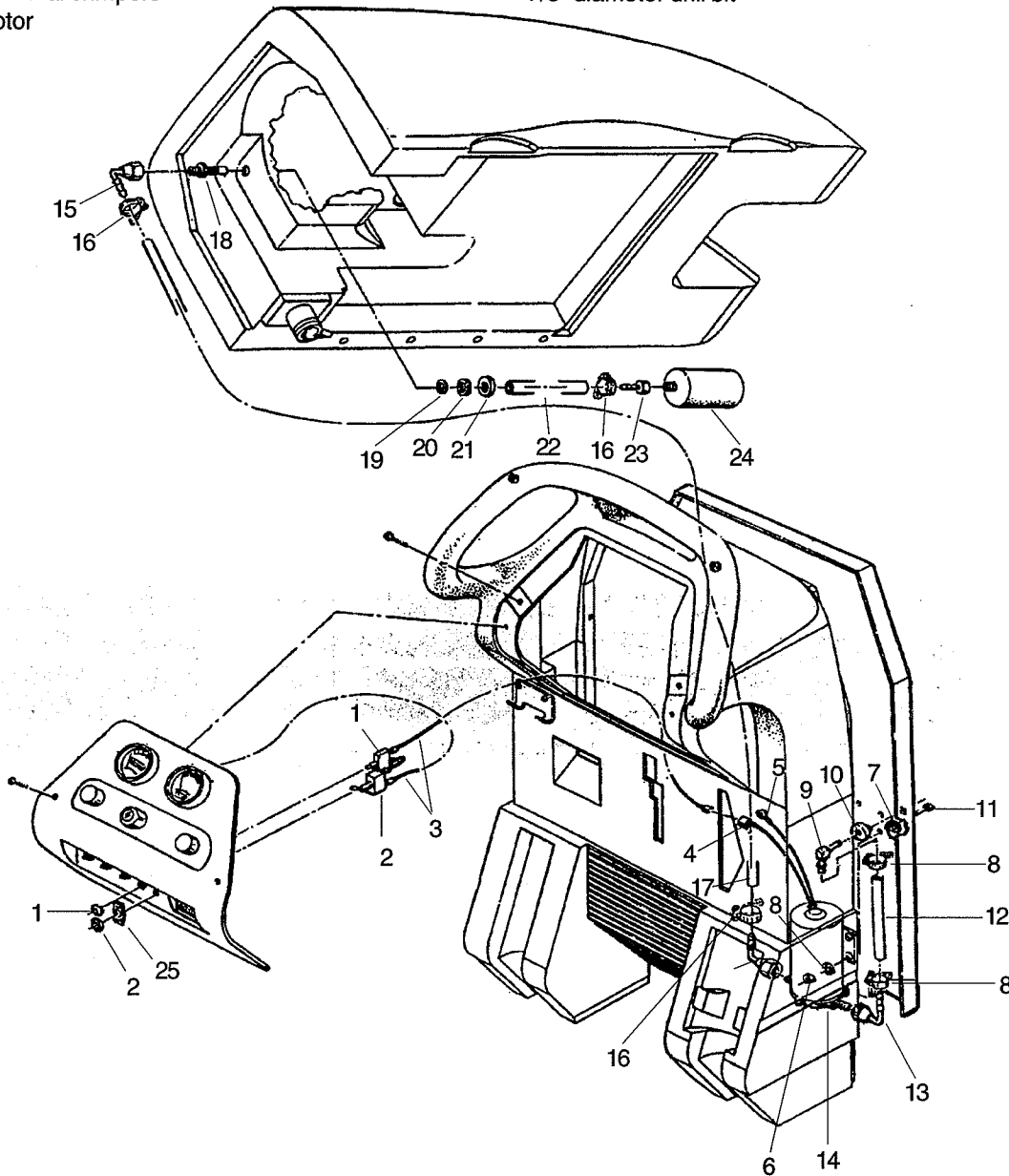

Ref #	Part No.	Description	Qty
1	41418B	Breaker, Circuit 10 Amp	1
2	47320A	Toggle Switch	1
3	49770A	Harness, ESP	1
4	47905A	Terminal, Male Q.D.	1
5	911933	Terminal, Ring	1
6	920296	Nut, 10-24 ESNA	4
7	980643	Washer #10	8
8	722021	Hose Clamp	2
9	51526A	Barb, 90°	1
10	51518A	Bushing	1
11	962862	Screw 10-24 x 1½	4
12	30172A	Hose 8"	1
13	692870	Elbow, Swivel	1

Ref #	Part No.	Description	Qty
14	45937A	Pump	1
15	53631A	Elbow, Swivel Pump	2
16	722030	Hose clamp	3
17	30451A	Hose PVC	1
18	50342A	Adapter, Recovery Tank	1
19	56682A	O Ring	1
20	980019	Washer, Nylon	1
21	920802	Nut, Nylon	1
22	30452A	Hose, Clear 17½"	1
23	55112A	Hose Barb	1
24	53997A	Filter	1
25	646302	Plate, Switch	1
NI	699202	Cable Ties	12

Clarke®
Encore S20
Powerwand System Kit 10662A

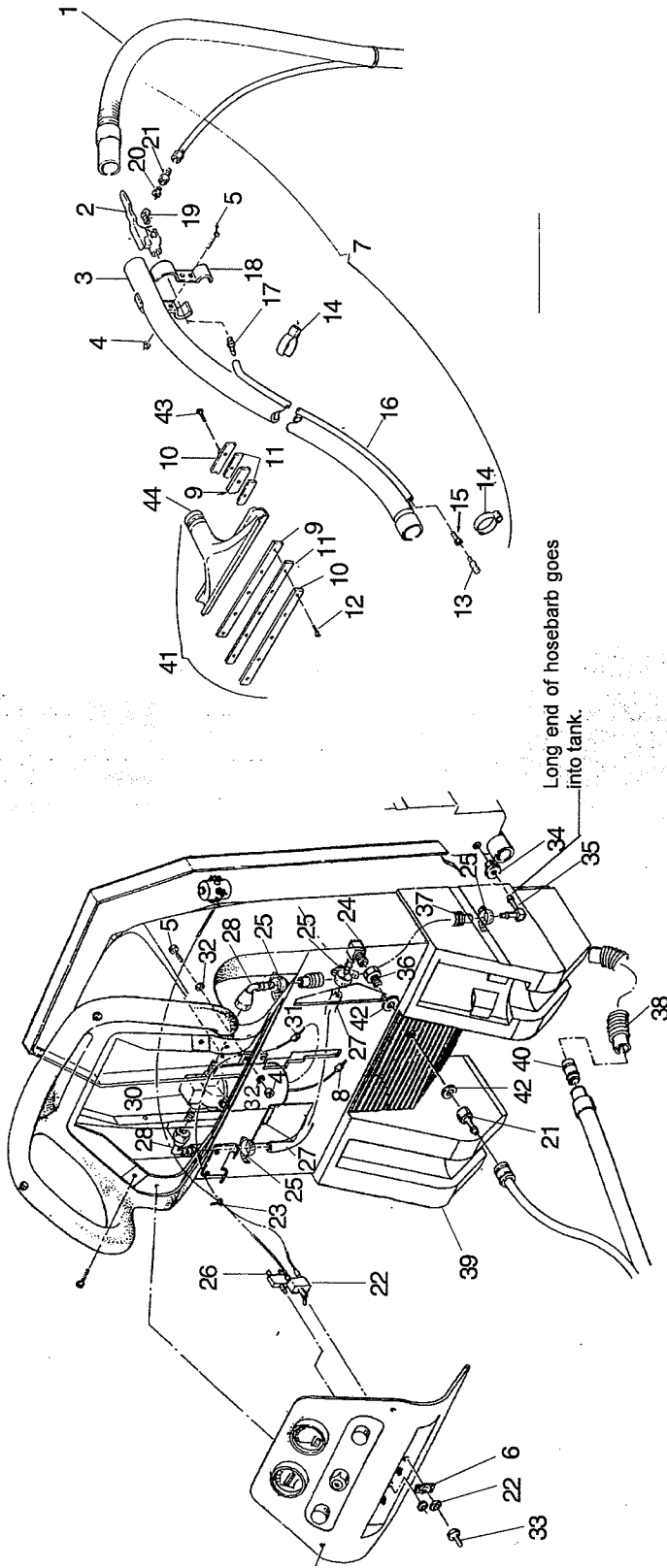

Ref #	Part No.	Description	Qty
24	53607A	Elbow, Hosebarb	1
25	722021	Clamp, Hose	4
26	41431A	Circuit Breaker 35A	1
27	30450A	Hose Clear 14"	1
28	632870	Elbow	2
29	631806	Floor Tool	1
30	45937A	Pump - 24V	1
31	911933	Terminal, Ring	1
32	980643	Washer, Flat #10	8
33	751321	Boot, Switch	1
34	51518A	Bushing	1
35	51526A	Barb 90°	1
36	727595	Reducer	1
37	35138A	Hose	1
38	-----	Existing Squeegee Vac Hose (ref.)	(ref.)
39	-----	Rear Cover (ref.)	(ref.)
40	682408	Hose Connector	1
*41	638828	Floor Tool Assembly	1
42	980673	Washer	2
43	962122	Screw 8-32 x 5/8FH	5
44	639002	Tube, Adapter	1
NI	699202	Wire Tie	12

Ref #	Part No.	Description	Qty
1	59232A	Hose Assembly	1
2	699450	Valve	1
3	639804	Wand Assembly	1
4	920296	Nut, 10-24 Nylok	6
5	962862	Screw, 10-24 x 1 1/2 PN	6
6	646302	Plate, Switch	1
7	19518A	Spray Wand Assembly	1
8	47704A	Terminal	1
9	30916A	Inner Blade	2
10	682012	Blade Clamp	2
11	30917A	Blade, Outer	3
12	84200A	Screw, 8-32 x 1/2 FH	5
13	54149A	Nozzle, Wand	1
14	722195	Hose Clip	4
15	50301A	Adapter	1
16	30421A	Hose, Wand	1
17	720271	Adapter	1
18	62426A	Clamp, Valve	2
19	722824	Elbow, 1/4-45°	1
20	697501	Reducer	1
21	737140	G.D. Male	2
22	47320A	Toggle Switch	1
23	49771A	Harness, Wiring	1

*NOTE: #41 includes- #s 9-12, 29, 43

**Clarke®
Encore S20 Parts List
Brush Meter Kit 10667A**

Parts included in Kit:

1	40218A	Brush Meter
1	79045A	Instruction Sheet
1	49775A	Brush Meter Harness
1	699202	Cable Ties

**Clarke®
Encore S20 Parts List
Hour Meter Kit 10656A**

Kit includes:

<u>Part No.</u>	<u>Description</u>	<u>Qty.</u>
43202A	Harness, Hour Meter	1
912226	Meter, Hour	1

Clarke® Encore S20/L20 Low Voltage Cut-Off Kit 14097A

GENERAL: The purpose of this device is to prevent over discharge of the brush motor(s) when the battery pack voltage falls too low. A high current load may be controlled by this module by wiring the brush motor(s) automatically and without warning, do NOT install this module.

WARNING: After installing this device, the brush motor(s) will turn off automatically and without warning.

WARNING: If there is any possible hazard in turning off the brush motor(s) automatically and without warning, do NOT install this module.

WARNING: This module will NOT control a high current load directly. A high current load may be controlled by this module by wiring the brush motor(s) to turn off the coil of a solenoid.

NOTE: This module will NOT protect against low voltage damage caused by any other non-controlled function.

OUTLINE DRAWING

MOUNTING: This device may be mounted in any position as long as it is securely fastened. It is recommended that the module be mounted in a vertical position. The mounting holes are spaced 1 1/4" apart in a straight line in the selected location.

Page 1

INSTALLATION INSTRUCTIONS FOR LOW VOLTAGE CUT-OFF MODULE

If it has been determined that shutting off the brush motor(s) will create any possible hazard, inspect the schematic of your machine to locate the control wires for the brush motor solenoid.

This module is to be wired in series with the coil of the brush motor. Connect the red (B+) wire from the module to one of the white (LOAD) wires from the solenoid's operating coil and joining this wire to the original control wire was removed. The module must not interrupt more than 1 amp or it may be damaged.

Connect the black (B-) to a source of positive battery voltage. The black wire must be connected to the positive terminal on the load side of the disconnect plug. This is the plug that is not attached to the battery pack. If your machine does not have a disconnect plug, connect the red and black wires to the load side of the brush motor's switch. The black side of the switch that turns on and off, not the "hot" side. Proper polarity must be observed for correct module operation.

TRIPPING: When the battery pack voltage falls low enough to require recharging, the brush motor(s) will stop and the L.E.D. on the module will come on. These two indications tell the operator the batteries are low and must be recharged.

RESETTING: To reset the module, recharge the batteries. The machine main power switch must be turned off before recharging the batteries for the module to reset properly.

Page 2

SPECIFICATIONS:

GENERAL: This device shall be used to prevent damage to the brush motor(s) by shutting off the brush motor(s) when a control circuit when a low voltage condition is detected.

DETECTION: A low voltage condition shall be detected when the voltage between B+ and B- falls below the TRIP VOLTAGE for the module.

TRIP TIME: Upon tripping, the internal relay contacts shall open within 100 milliseconds.

RESET: The contacts of the internal relay shall be re-closed by waiting the RESET TIME with no voltage between B+ and B- and the re-applying a voltage greater than the RESET VOLTAGE.

TRIP VOLTAGE: 21.0 VDC +/- 0.5 VDC

TRIP TIME: 10 seconds +/- 2 seconds

RESET TIME: 100 seconds +/- 10 seconds

RESET VOLTAGE: 23.5 VDC +/- 0.5 VDC

RATED SYSTEM VOLTAGE: 24 VDC

CONTROL CIRCUIT CURRENT: Up to 1 Amp @ 24 VDC

PACKAGE: Plastic container 1.5" H x 2" W x 3" L with two 0.185" diameter holes on 2.5" centers.

TRIP INDICATOR: Red LED centered between mounting holes turns on when in tripped condition.

CONNECTIONS: Current carrying wires shall be 36" long. B+ to be red, B- to be black, and LOAD to be white.

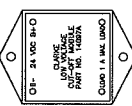
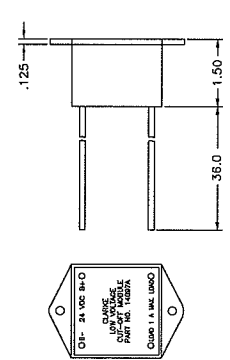
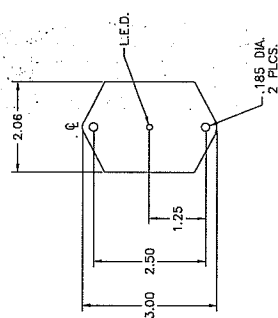

1. ONE (1) COPY OF INSTALLATION INSTRUCTIONS TO BE PACKAGED WITH ONE (1) MODULE TO PRODUCE ONE (1) KIT.

**SEE
PAGES 56-62
FOR
COMPONENTS
FOR MACHINES
WITH A
41150B
TRAVERSE
CONTROLLER**

Clarke®
Encore S20/L20
Rear Panel Assembly Drawing 7/02
(for machines with a 41150B traverse controller)

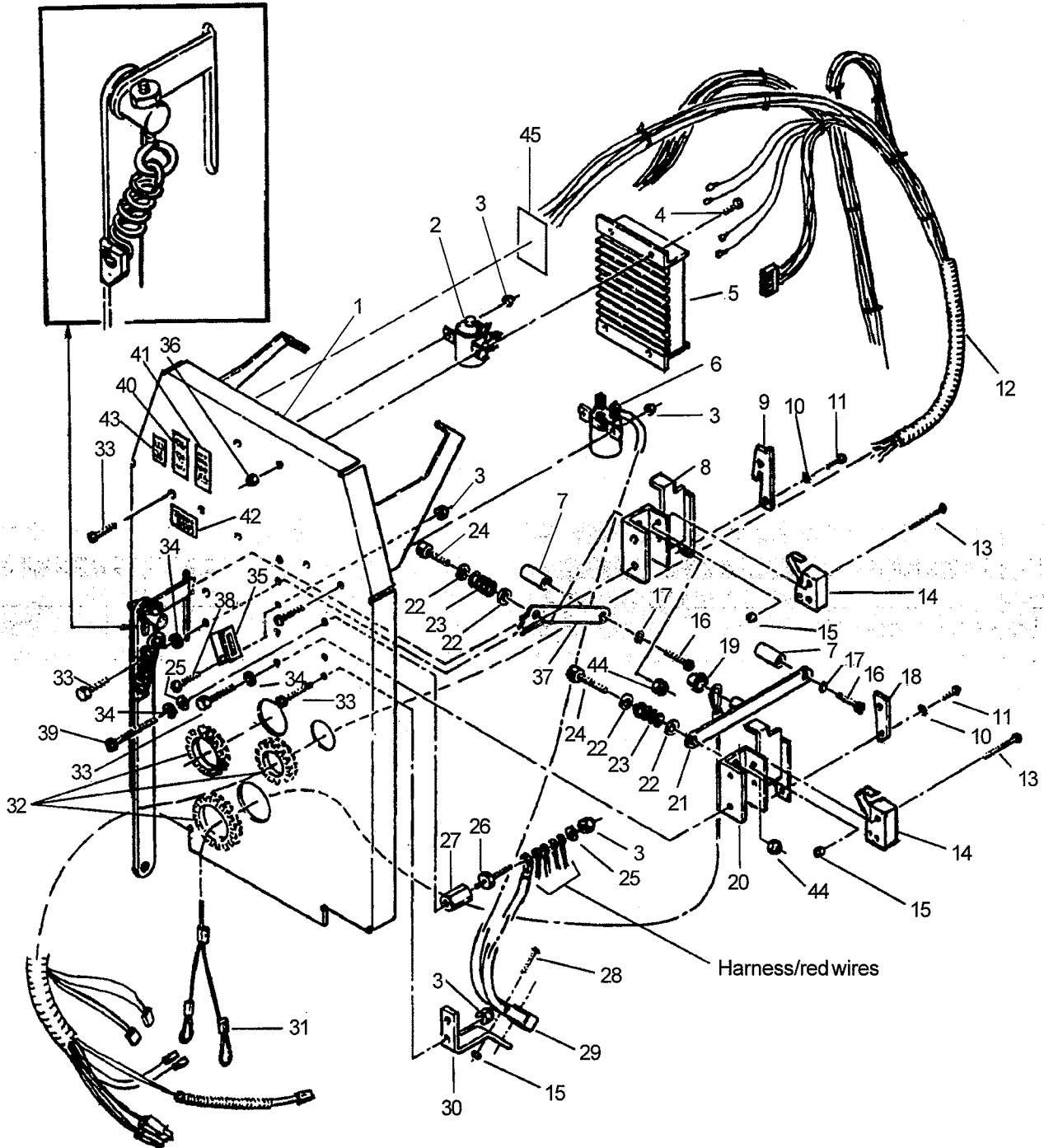

Clarke®
Encore S20/L20
Rear Panel Assembly Parts List 7/02
(for machines with a 41150B traverse controller)

Ref #	Part No.	Description	Qty. L20	Qty. S20
1	68787A	Panel, Rear	1	1
2	878514	Solenoid, Vac	1	1
3	81104A	Nut, ¼-20	9	9
4	962798	Screw	4	0
5	41150B	Control, Speed	1	0
6	41810A	Solenoid, Brush	1	1
7	64490A	Handle	2	2
8	68789A	Lift, Brush	1	1
9	64231A	Plate, Wear, Lift, Brush	1	1
10	980603	Washer	4	4
11	962546	Screw, 10-24 x ½	4	4
12	49765A	Harness, Power L20	1	-
	49766A	Harness, Power S20	-	1
13	85601A	Screw, 6-32 x 1¼ PN	4	4
14	47388A	Switch	2	2
15	920056	Nut, 6-32	6	6
16	85389A	Screw, ¾-16 x 5/8	2	2
17	980666	Washer, Starlock, ¾	2	2
18	68643A	Plate, Wear, Vac	1	1
19	920346	Nut, Pal	1	1
20	61260A	Squeegee Lift Plate	1	1
21	64901A	Handle, Lift, Squeegee	1	1
22	980692	Washer, Flat, 5/16 SS	4	4
23	438360	Spring	2	2
24	80028A	Bolt, Shoulder, 5/16 x 1.0	2	2
25	87026A	Washer, Flat, ¼	2	2
26	83302A	Stud	1	1
27	854849	Insulator	1	1
28	962212	Screw, 6-32 x 7/8	2	2
29	41146A	Panel Power Harness	1	1
30	60676A	Bracket, Connector, Power	1	1
31	61677A	Cable, Lift, Squeegee	1	1
32	54606A	Grommet, Slotted, 7.75"	3	3
33	170915	Screw, ¼-20 x ¾ Hex	10	10
34	980657	Washer, Lock, ¼	5	5
35	69858A	Latch, Tank, Recovery	1	1
36	81110A	Nut, 10-24 ESNA	4	-
37	64498A	Handle, Lift, Brush	1	1
38	85391A	Screw, ¼-20 x 5/8	2	2
39	85395A	Screw, ¼-20 x ½	1	1
40	77093A	Label	1	1
41	77092A	Label	1	1
42	70302A	Label, Battery Install	1	1
43	77233A	Label, CE	1	1
44	81217A	Nut, ¼-20 x .218H Nylock	2	2
45	70078A	Label, Traverse Troubleshooter	1	-

Clarke® Encore S20/L20
Electrical Cover Assembly Drawing and Parts List 7/02
(for machines with a 41150B traverse controller)

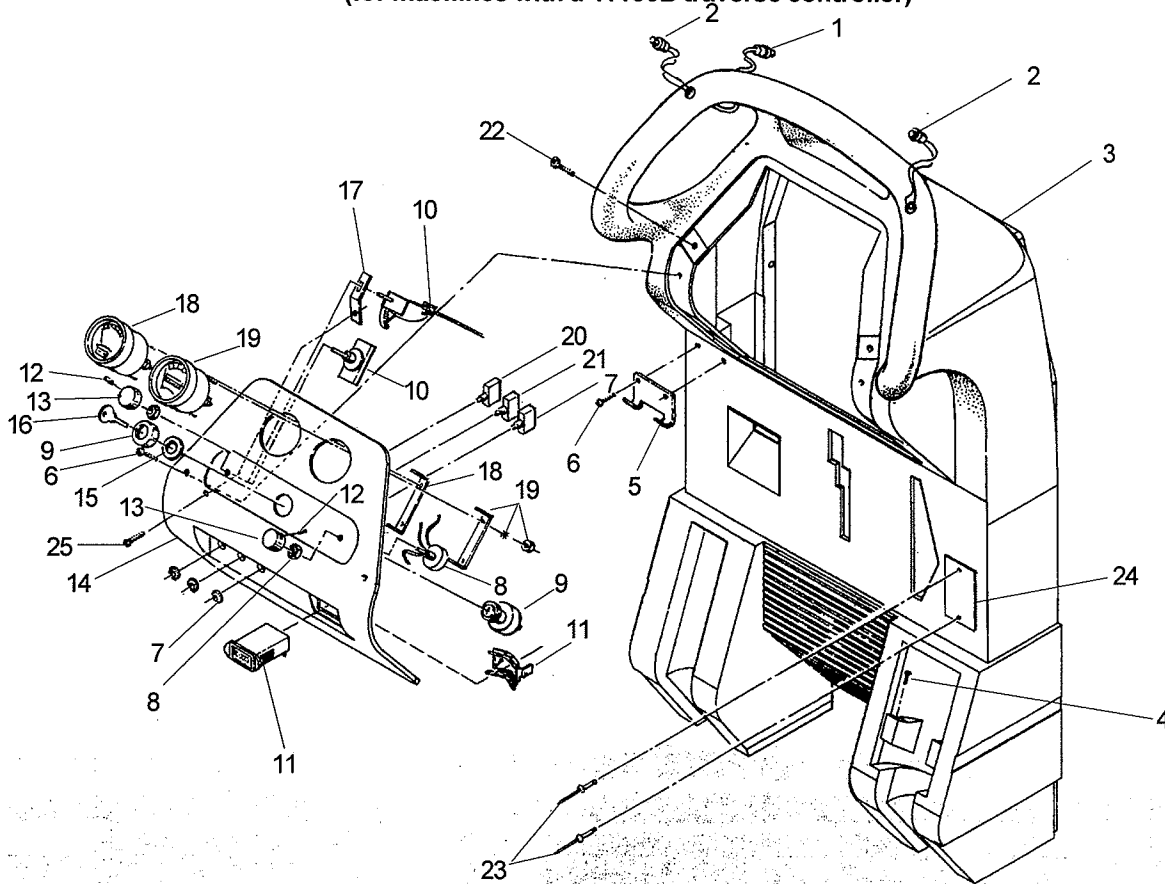

Ref #	Part No.	Description	Qty. L20	Qty. S20
1	53078B	Switch, Reverse	1	-
2	53077B	Switch, Forward/Reverse	2	-
3	30252A	Cover, Rear Encore 20L	1	-
	30253A	Cover, Rear Encore 20S	-	1
4	962957	Screw	2	2
5	66987A	Hanger, Hose	1	1
6	84237A	Screw	4	4
7	41433A	Breaker, 40 Amp, Brush	1	1
8	45702A	Potentiometer, Asm. (Included w/mach. harness 49765A)	1	-
9	47380A	Switch, Key	1	1
10	44308B	Control, Flow, Solution	1	-
	11703A	Cable, Solution	-	1
11	912226	Meter, Hour	1	-
12	962262	Screw, Set, 8-32 x 1/4	2	1
13	55502A	Knob	2	1
14	32405A	Panel, Control L20	1	-
	32413A	Panel, Control S20	-	1
15	87052A	Washer, Switch	1	1
16	55413A	Key (included with #9)	2	2
17	66988A	Retainer, Clip	-	1
18	40217B	Meter, Battery	1	1
19	40218A	Meter, Brush	1	-
20	41422A	Breaker, 25 Amp, Traverse	1	-
21	41448A	Breaker, 30 Amp, Vac	1	1
22	85518A	Screw, 1/4-20 x 3/4 PN	2	2
23	83010A	Rivet	2	2
24	70080A	Plate (models without brake)	1	1
	70079A	Plate (models with brake)	1	1
25	85388A	Screw 10-24 x 1/2 TP-F	-	1
NI	47708A	1/4 F.I.M.Q.D	6	-
NI	47700A	1/4 F.I.F.Q.D	1	-

Clarke®
Encore L20
Electrical Schematic (00880A-E) 7/02
(for machines with a 41150B traverse controller)

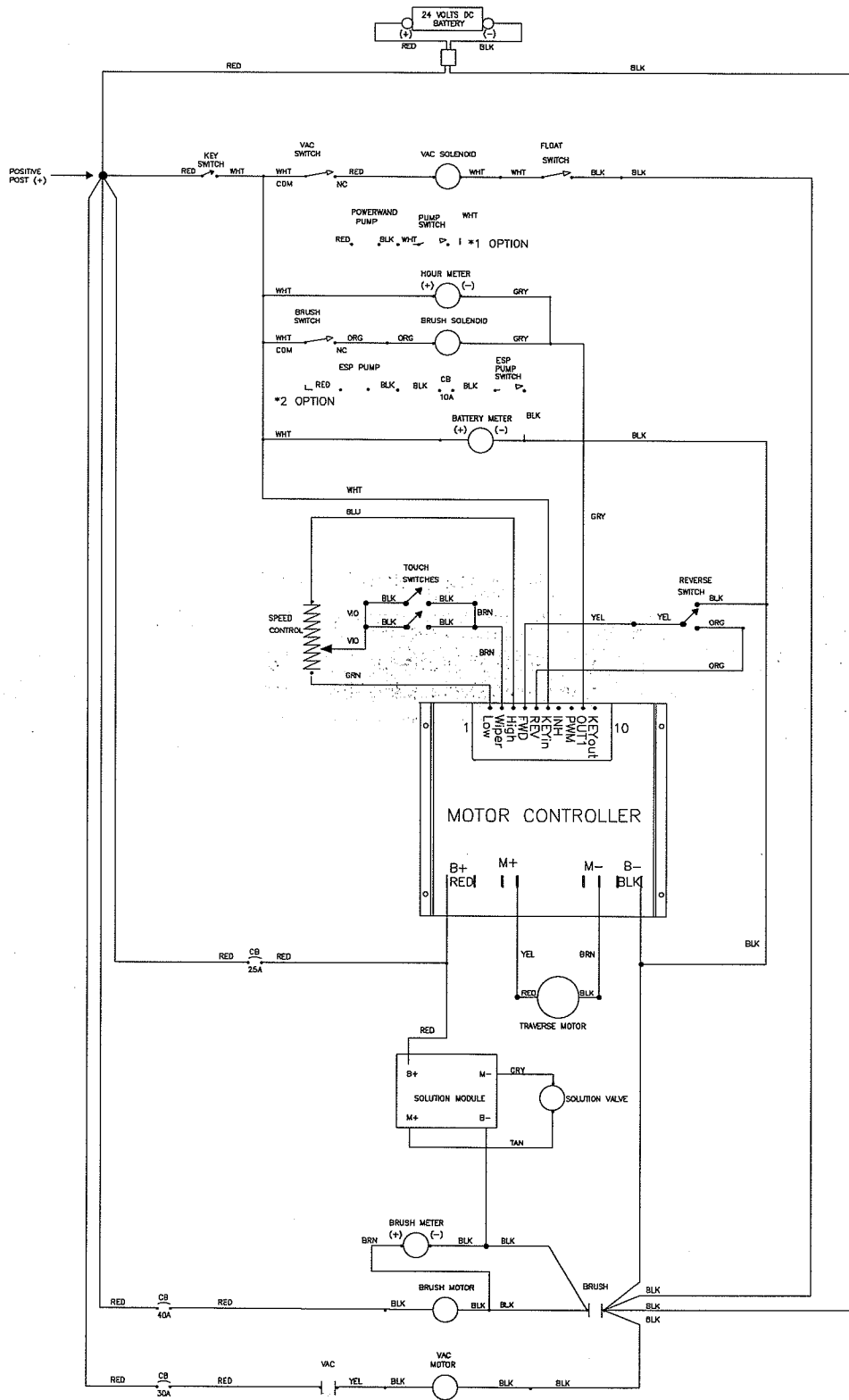

*1 OPTION = POWERWAND
 *2 OPTION = ESP RECYCLE

Clarke®
Encore L20
Connection Diagram (00880A-W) 7/02
(for machines with a 41150B traverse controller)

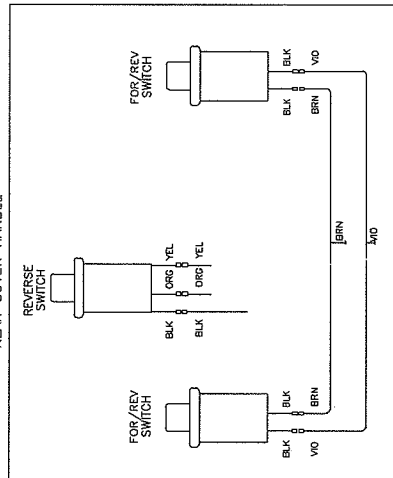
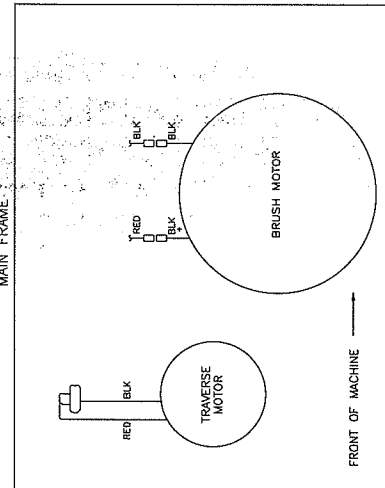
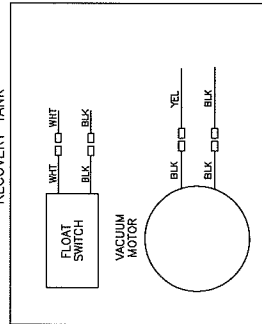
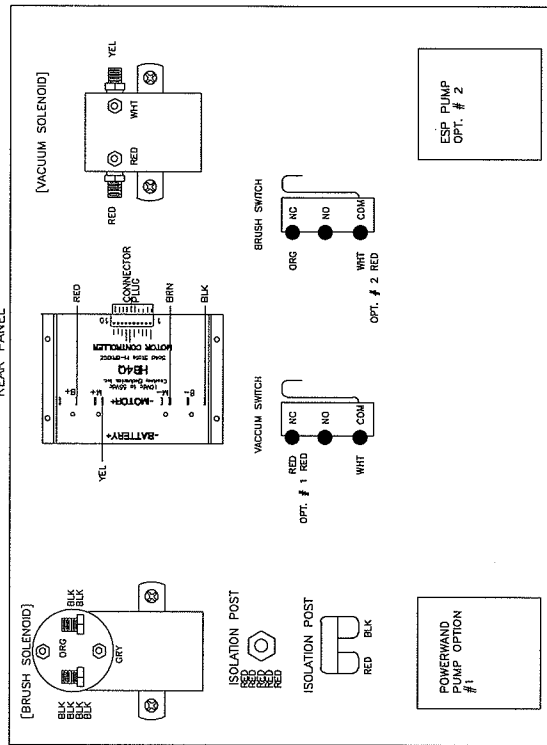
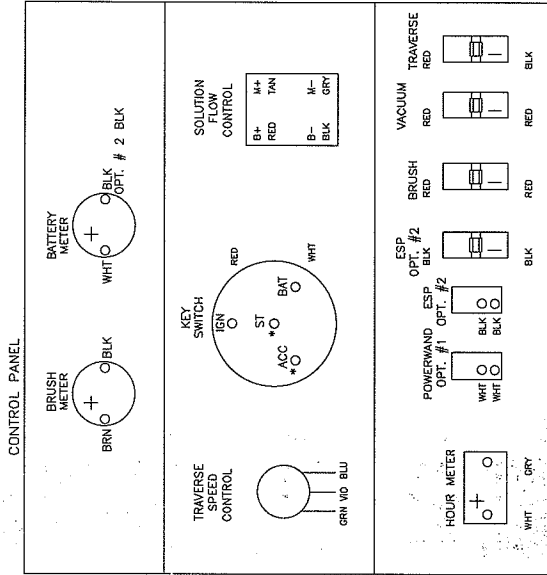

* = NOT CONNECTED
 OPT. #1 = POWERWAND OPTION
 OPT. #2 = EXTENDED SCRUB OPTION

Clarke®
Encore S20
Connection Diagram (00890A - W) 7/02
(for machines with a 41150B traverse controller)

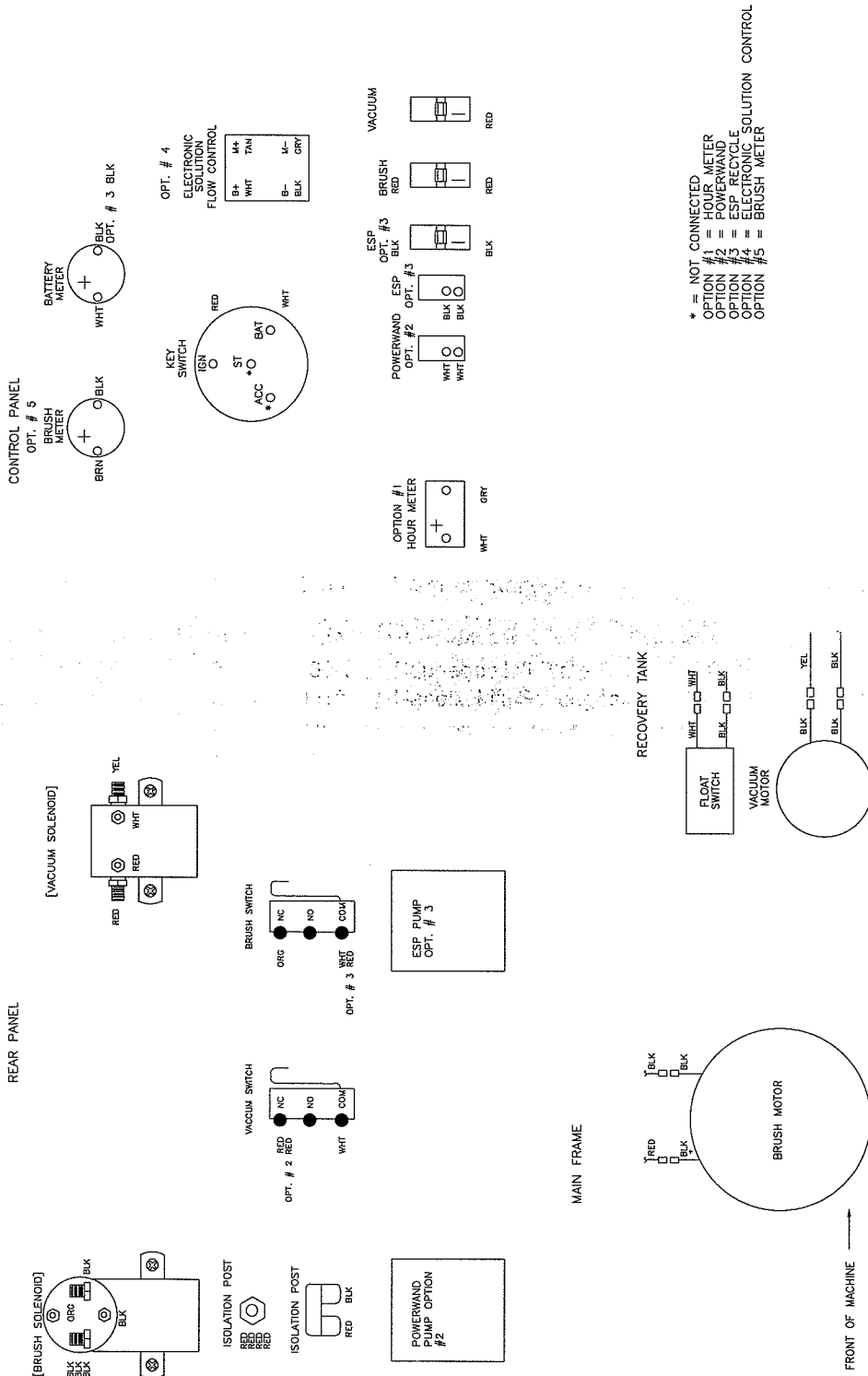

* = NOT CONNECTED
 OPTION #1 = HOUR METER
 OPTION #2 = POWERWAND
 OPTION #3 = ESP RECYCLE
 OPTION #4 = ELECTRONIC SOLUTION CONTROL
 OPTION #5 = BRUSH METER

**SEE
PAGES 64-68
FOR
COMPONENTS
FOR MACHINES
WITH A
41150C
TRAVERSE
CONTROLLER**

Clarke®
Encore L20
Rear Panel Assembly Drawing 2/03
(for machines with a 41150C traverse controller)

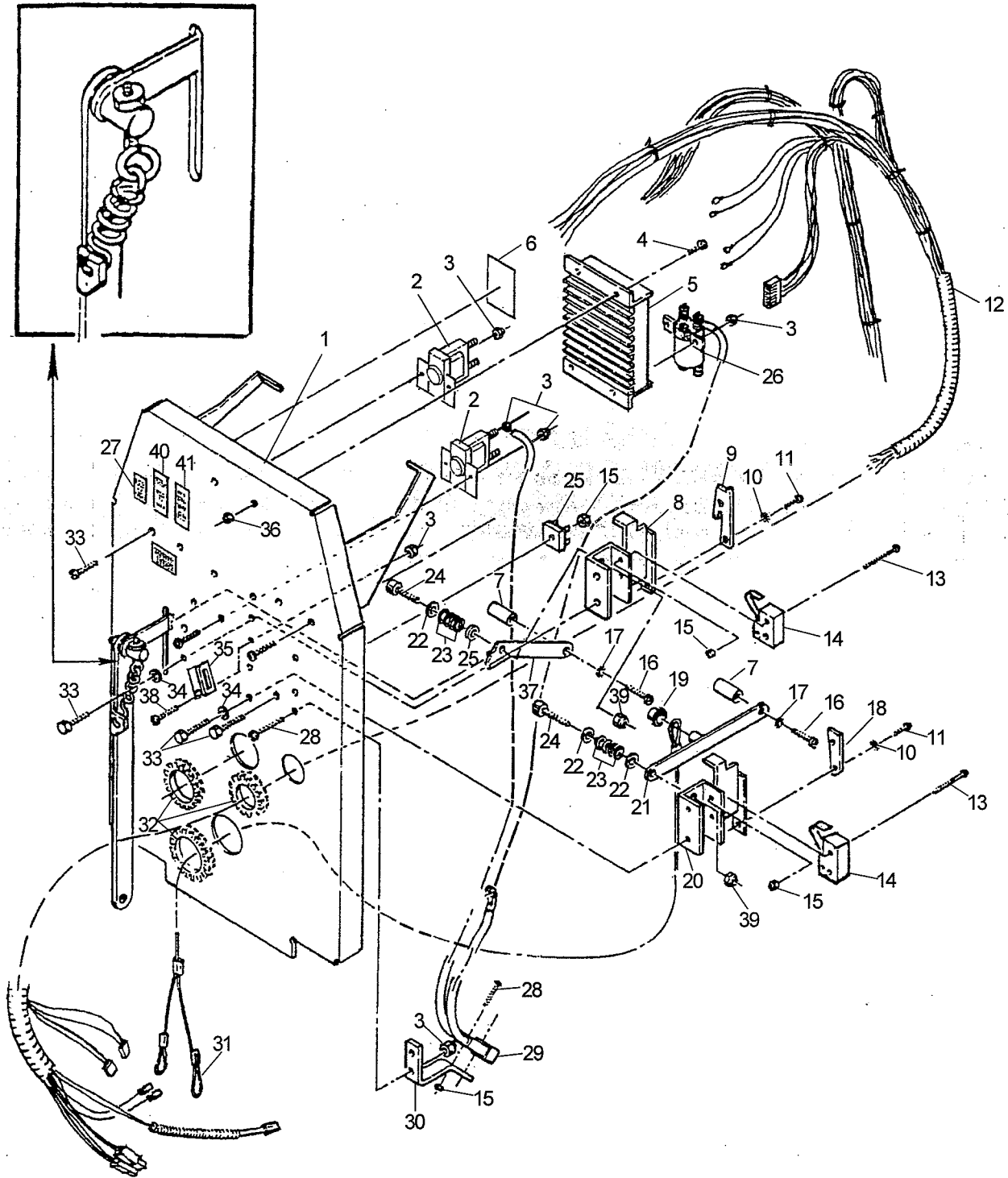

Clarke®
Encore L20
Rear Panel Assembly Parts List 2/03
(for machines with a 41150C traverse controller)

Ref #	Part No.	Description	Qty. L20
1	68787A	Panel, Rear	1
2	40169A	Solenoid	2
3	81104A	Nut, 1/4-20	10
4	962798	Screw	4
5	41150C	Control, Speed	1
6	77233A	Label, CE	1
7	64490A	Handle	2
8	68789A	Lift, Brush	1
9	64231A	Plate, Wear, Lift, Brush	1
10	980603	Washer	4
11	962546	Screw, 10-24 x 1/2	4
12	49765B	Harness, Power L20	1
13	85601A	Screw, 6-32 x 1 1/4 PN	4
14	47388A	Switch	2
15	920056	Nut, 6-32	7
16	85389A	Screw, 3/8-16 x 5/8	2
17	980666	Washer, Starlock, 3/8	2
18	68643A	Plate, Wear, Vac	1
19	920346	Nut, Pal	1
20	61260A	Squeegee Lift Plate	1
21	64901A	Handle, Lift, Squeegee	1
22	980692	Washer, Flat, 5/16 SS	4
23	438360	Spring	2
24	80028A	Bolt, Shoulder, 5/16 x 1.0	2
25	46106A	Rectifier	1
26	41811A	Solenoid	1
27	70078A	Label, Traverse Troubleshooter	1
28	962212	Screw, 6-32 x 7/8	3
29	41146A	Panel Power Harness	1
30	60676A	Bracket, Connector, Power	1
31	61677A	Cable, Lift, Squeegee	1
32	54606A	Grommet, Slotted, 7.75"	3
33	170915	Screw, 1/4-20 x 3/4 Hex	11
34	980657	Washer, Lock, 1/4	4
35	69858A	Latch, Tank, Recovery	1
36	81110A	Nut, 10-24 ESNA	4
37	64498A	Handle, Lift, Brush	1
38	85391A	Screw, 1/4-20 x 5/8	2
39	81217A	Nut, 1/4-20 x .218H Nylock	2
40	77093A	Label	1
41	77092A	Label	1
42	70302A	Label, Battery Install	1

Clarke® Encore S20/L20
Electrical Cover Assembly Drawing and Parts List 2/03
(for machines with a 41150C traverse controller)

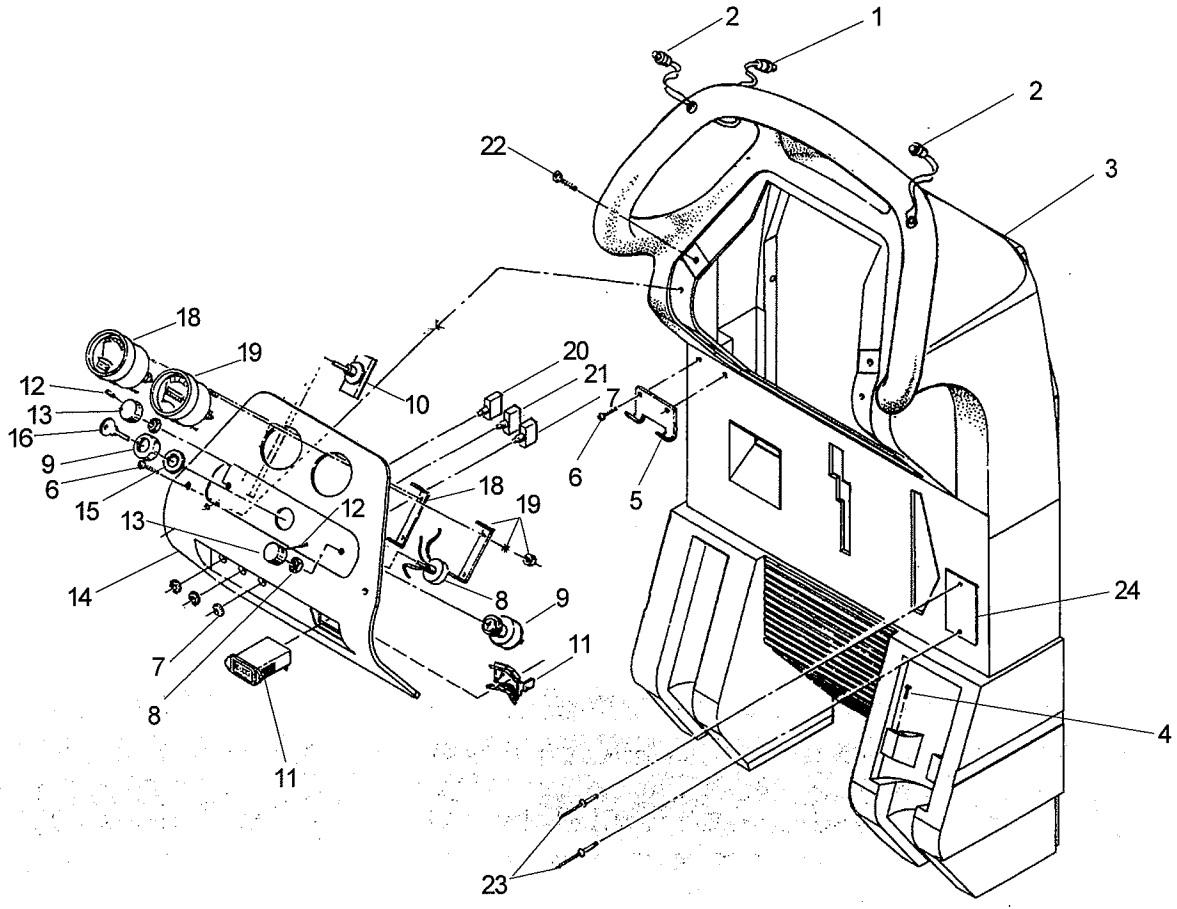

Ref #	Part No.	Description	Qty. L20
1	40158A	Switch, Reverse	1
2	53077B	Switch, Forward/Reverse	2
3	32415B	Cover, Rear Encore 20L	1
4	962957	Screw	2
5	66987A	Hanger, Hose	1
6	84237A	Screw	4
7	41433B	Breaker, 40 Amp, Brush	1
8	45702A	Potentiometer, Asm. (Included w/mach. harness 49765B)	1
9	47380A	Switch, Key	1
10	44308B	Control, Flow, Solution	1
11	912226	Meter, Hour	1
12	962262	Screw, Set, 8-32 x 1/4	2
13	55502A	Knob	2
14	32405A	Panel, Control L20	1
15	87052A	Washer, Switch	1
16	55413A	Key (included with #9)	2
18	40217B	Meter, Battery	1
19	40218A	Meter, Brush	1
20	41422B	Breaker, 25 Amp, Traverse	1
21	41448B	Breaker, 30 Amp, Vac	1
22	85518A	Screw, 1/4-20 x 3/4 PN	2
23	83010A	Rivet	2
24	70080A	Plate (models without brake)	1
	70079A	Plate (models with brake)	1
NI	47708A	1/4 F.I.M.Q.D	6
NI	47712A	1/4 F.I.F.Q.D	1

Clarke®
Encore L20
Electrical Schematic (00880A-E) 4/03
(for machines with a 41150C traverse controller)

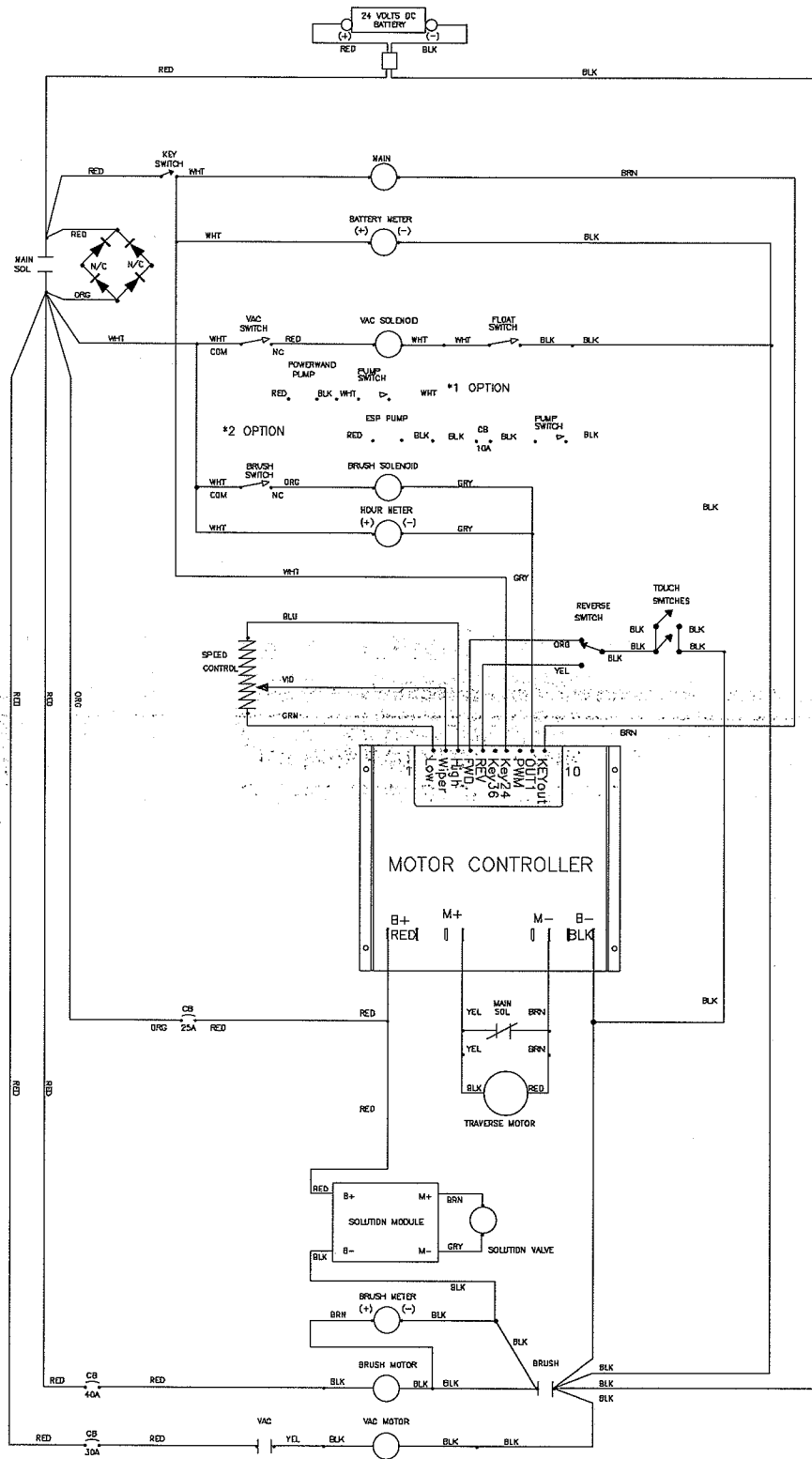

*1 OPTION = POWERWAND
 *2 OPTION = ESP RECYCLE

Clarke® Encore L20 Connection Diagram (00880A-W) 2/04 (for machines with a 41150C traverse controller)

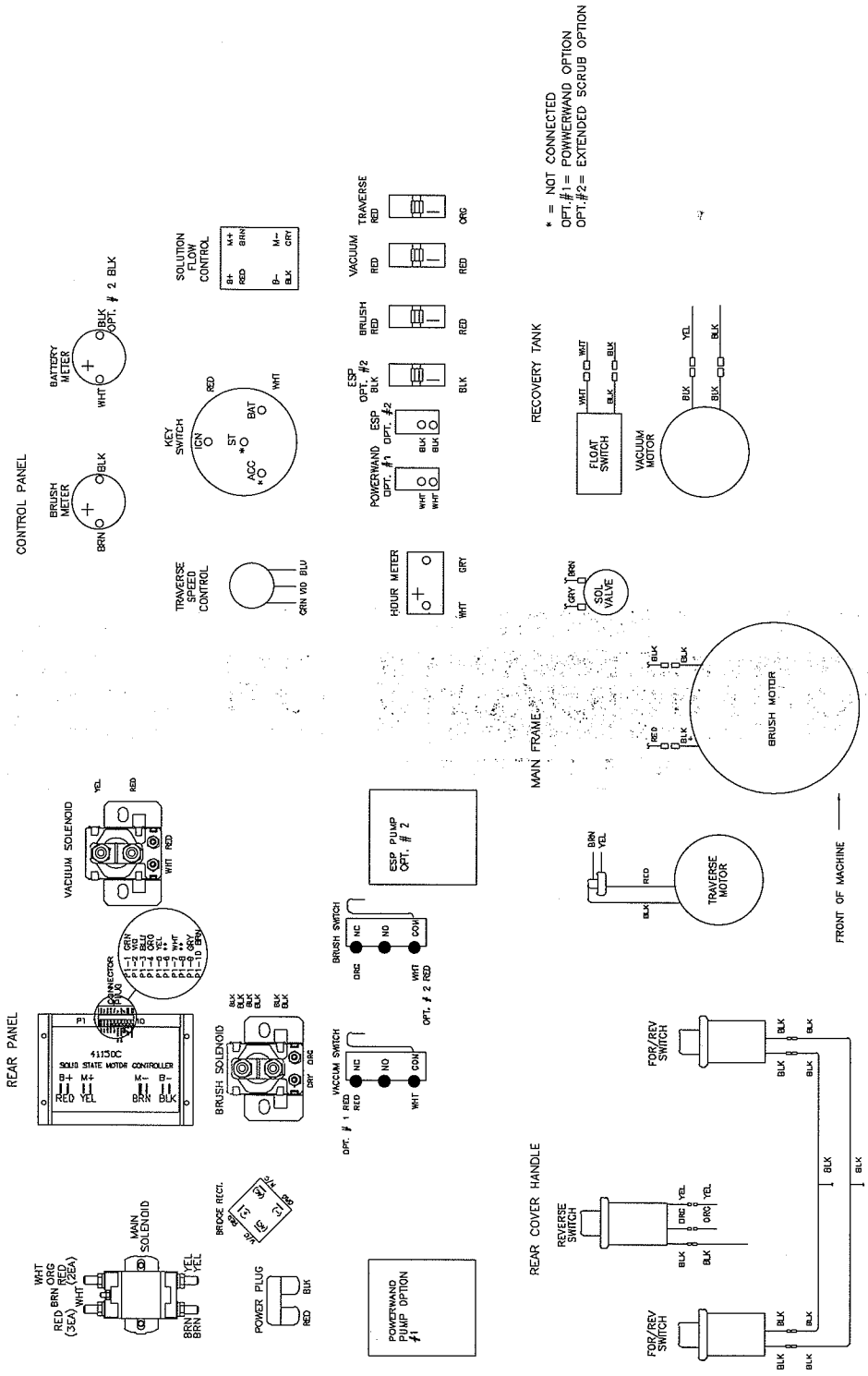

* = NOT CONNECTED
OPT.#1 = POWERWAND OPTION
OPT.#2 = EXTENDED SCRUB OPTION

CLARKE PRODUCT SUPPORT BRANCHES

U. S. A. Locations

PRODUCTION FACILITIES

Clarke®, Springdale, Arkansas
2100 Highway 265
Springdale, Arkansas 72764
(479) 750-1000
Customer Service - 1-800-253-0367
Technical Service - 1-800-356-7274

American Lincoln®, Bowling Green, Ohio 43402
1100 Haskins Road

SERVICE FACILITIES

Clarke®, Elk Grove, Illinois 60007
2280 Elmhurst Road
(847) 956-7900

Clarke®, Denver, Colorado 80204
1955 West 13th Ave.
(303) 623-4367

Clarke®, Houston, Texas 77040
7215 North Gessner Road
713-937-7717

SERVICE AND SALES FACILITY

American Lincoln® / Clarke, Madison Heights,
Michigan 48071-0158
29815 John R.
(810) 544-6300

American Lincoln® / Clarke, Marietta, Georgia 30066
1455 Canton Road
(770) 973-5225

Clarke®

Clarke American Sanders

A.L. Cook

Customer Service Headquarters and Factory
2100 Highway 265
Springdale, Arkansas 72764
(479) 750-1000

Technical Service
1-800-356-7274

European Locations

PRODUCTION FACILITIES

ALTO Danmark A/S, Aalborg
Blytaekkervej 2
DK-9000 Aalborg
+45 72 18 21 00

ALTO Danmark A/S, Hadsund
Industrivarveret
DK-9560 Hadsund
+45 72 18 21 00

SALES SUBSIDIARIES

ALTO US - Canada, Ontario (Canada)
4080 B Sladeview Crescent Unit 1
Mississauga, Ontario L5L 5Y5
(905) 569 0266

ALTO Overseas Inc., Sydney (Australia)
1B/8 Resolution Drive
Caringbah NSW 2229
+61 2 9524 6122

ALTO Cleaning Systems Asia Pte Ltd., Singapore
No. 17 Link Road
Singapore 619034
+65 268 1006

ALTO Deutschland GmbH, Bellenberg (Germany)
Guido-Oberdorfer-Straße 2-8
89287 Bellenberg
+49 0180 5 37 37 37

ALTO Cleaning Systems (UK) Ltd., Penrith
Gilwilly Industrial Estate
Penrith
Cumbria CA11 9BN
+44 1768 868 995

ALTO France S.A. Strasbourg
B.P. 44, 4 Place d'Ostwald
F-67036 Strasbourg
Cedex 2
+33 3 8828 8400

ALTO Nederland B.V.
Postbus 65
3370 AB Hardinxveld-Giessendam
The Netherlands
+31 184 677 200

ALTO Sverige AB, Molndal (Sweden)
Aminogatan 18
Box 4029
S-431 04 Molndal
+46 31 706 73 00

ALTO Norge A/S, Oslo (Norway)
Bjornerudveien 24
N-1266
+47 2275 1770

Clarke® U.S. WARRANTY

This Clarke Industrial/Commercial Product is warranted to be free from defects in materials and workmanship under normal use and service for a period of one year from the date of purchase, when operated and maintained in accordance with Clarke's Maintenance and Operations Instructions.

This warranty is extended only to the original purchaser for use of the product. It does not cover normal wear parts such as electrical cable, rubber parts, hoses and motor brushes.

If difficulty develops with the product, you should:

- (a). Contact the nearest authorized Clarke repair location or contact the Clarke Service Operations Department, 2100 Highway 265, Springdale, Arkansas 72764, for the nearest authorized Clarke repair location. Only these locations are authorized to make repairs to the product under this warranty.
- (b). Return the product to the nearest Clarke repair location. Transportation charges to and from the repair location must be prepaid by the purchaser.
- (c). Clarke will repair the product and/or replace any defective parts without charge within a reasonable time after receipt of the product.

Clarke's liability under this warranty is limited to repair of the product and/or replacement of parts and is given to purchaser in lieu of all other remedies, including INCIDENTAL AND CONSEQUENTIAL DAMAGES.

THERE ARE NO EXPRESS WARRANTIES OTHER THAN THOSE SPECIFIED HEREIN. THERE ARE NO WARRANTIES WHICH EXTEND BEYOND THE DESCRIPTION OF THE FACE HEREOF. NO WARRANTIES, INCLUDING BUT NOT LIMITED TO WARRANTY OF MERCHANTABILITY, SHALL BE IMPLIED. A warranty registration card is provided with your Clarke product. Return the card to assist Clarke in providing the performance you expect from your new floor machine.

Clarke®, 2100 Highway 265, Springdale, Arkansas 72764.

Clarke® POLYDUR TANK EIGHT YEAR U.S. GUARANTEE

Your new Encore Auto Scrubber has a Polydur Tank. Polydur is a rotationally molded, low-density linear polyethylene that won't crack or dent, and withstands most corrosives and temperature extremes. Clarke backs up your Polydur Tank with its eight year guarantee. If a tank breaks, cracks, or leaks, within eight years, it will be replaced free.

Clarke reserves the right to make changes or improvements to its machine without notice.

Always use genuine Clarke Parts for repair.

Clarke®

**2100 Highway 265
Springdale, Arkansas, 72764**