



## **Electronic Service Manuals**

This electronic document is provided as a service to our customers. We do not create the contents of the information contained in this document. Should you have detailed questions pertaining to the information contained in this document, you may contact Michco, or the manufacturer which provided the original information in this electronic deliverable. Michco's only part in this electronic deliverable was the electronic assembly process. By providing this manual online we are not guaranteeing parts availability.

You may contact Michco through the following methods:

**Phone (517) 484-9312**

2011 N. High St. -- Lansing, Michigan -- 48906

Fax: (517) 484-9836

Email: [CustomerService@Michco.com](mailto:CustomerService@Michco.com)

Website: [www.Michco.Com](http://www.Michco.Com)

Order Parts online at:

**[www.Michco.Com](http://www.Michco.Com)**

Directly to Parts & Service:

By Email: **[CustomerService@Michco.com](mailto:CustomerService@Michco.com)**

By Fax: (517) 484-9836

By Voice: (517) 484-9312

**Serving the Cleaning Industry Since 1922**

Notice: All copyrighted material remains property of original owners, all trademarks are property of respective owners. Manuals are subject to Manufacturer's reproduction limitations. Originals or reproductions were provided by manufacturers through a request. We make no warranty as to the correctness of information provided in this document and you assume all risk. By placing these manuals on line we are not declaring our corporation to be an manufacturer authorized dealer or provider, please check our web site for authorized manufacturers we represent.



E29974



# FiberCAP™ 15

15" Carpet  
Cleaning Machine



**Operator Manual**



# GENERAL SAFETY REGULATIONS

**The regulations below must be carefully followed in order to avoid harm to the operator and damage to the machine.**

- Read all labels on the machine carefully. Do not cover them for any reason and replace them immediately if they become damaged.
- The machine must be used exclusively by authorized and trained personnel.
- When operating the machine be careful of other people.
- The power cable outlet must be provided with a proper ground.
- Avoid damaging the power cable by crushing, bending, cutting or stressing it.
- Whenever the power cable is damaged, immediately contact a BETCO service center.
- Do not set containers on the machine.
- Machine storage temperature is between -10°F and 130°F, never store outside under humid conditions.
- Operating conditions: room temperature between 33°F and 100°F with relative humidity between 30% to 95%.
- Only use the machine in closed areas and do not expose it directly to rain.
- Never use the machine in an explosive environment.
- Do not use the machine as a means of transport.
- Never use acidic chemicals which could damage the machine.
- Avoid running the brushes with the machine stopped; this could damage the floor.
- Never vacuum up flammable liquids.
- Never use the machine to gather dangerous powders.
- Use a powder fire extinguisher in case of fire. Do not use water.
- Do not hit against shelving or scaffolding. The operator must always be equipped with the appropriate safety device (gloves, shoes, helmet, glasses, etc.)
- If the machine does not work properly, perform routine maintenance. Otherwise, request the assistance of the BETCO technical service.
- When replacing parts ask for ORIGINAL spare parts from your Authorized BETCO Dealer and/or Retailer.
- Always turn off the machine and disconnect the power supply whenever maintenance is performed.
- Never use the machine without side guards or dust collection bins secured to the machine.
- **Never wash the machine with direct or pressurized jets of water or with corrosive substances.**
- Have your BETCO service center check the machine once a year.
- Before using the machine make sure that all doors and covers are positioned as shown in this operating and maintenance manual.
- When your BETCO machine is ready to be retired, the machine must be disposed of properly. It contains oils and electronic components. The machine was built using totally recyclable materials.
- Use only brushes furnished with the machine or those specified in the user's manual. Use of other brushes can compromise safety.

# MACHINE PREPARATION

## 1. ASSEMBLING THE HANDLE

The handle assembly is comprised of four individual parts.

- A. Install the main cross bar onto the machine by pulling the finger pins outward on both sides and locking them into the handle mounts of the machine.
- B. Insert the open end of both handle uprights into the cross bar.
- C. Insert the open end of the round handle bar into each of the handle uprights.

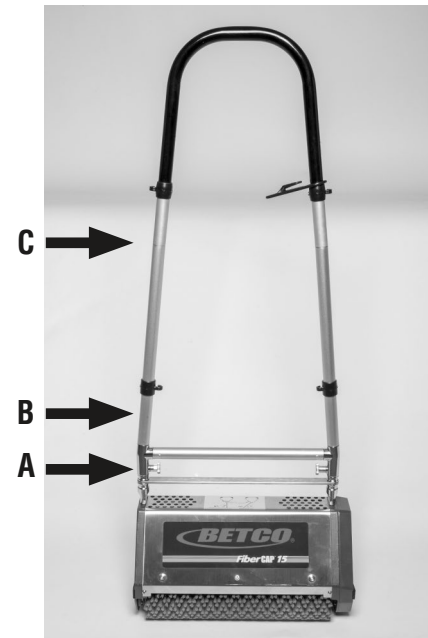

## 2. SIDE SHIELDS

Be sure the machine is not plugged in when performing this installation.

- A. Place the open end of the teardrop hole over the mounting pins.
- B. Slide the side shield to the right until the center spring pin locks it into place.
- C. Repeat this installation on the other side of the machine.



## 3. ASSEMBLING THE STORAGE TRAY

- A. Insert the metal support into the two holes on both sides of the plastic storage tray.
- B. Insert the metal axle through the single hole on both sides of the plastic storage tray.
- C. Attach the wheels to each end of the axle. The metal clip on the inside hub of the wheel should lock into place on the channel at each end of the axle.

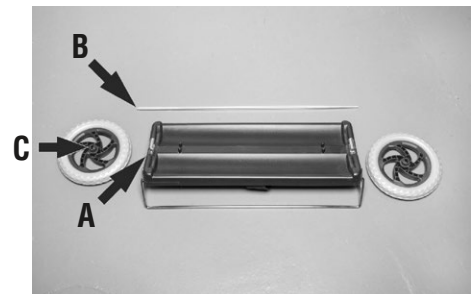

# MACHINE OPERATION

## 1. STARTING THE MACHINE

- A. Attach the extension cord to the plug on the machine.
- B. Insert cord through strain relief holder.
- C. Plug into a grounded 110V/120V outlet.
- D. Push down the start lever on the left side of the machine. The machine will automatically start when the handle is lowered to an operating position.
- E. To turn off the machine, simply raise the handle back to a locked an upright position. The machine will automatically stop.



**WARNING:** Be sure to keep loose carpets and cords from passing under the machine while in operation.



## 2. USING THE SWEEPING FUNCTION (Dust collection bins sold separately)

To use the machine as a sweeper, simply remove the side shields from the machine and install the optional dust collection bins.

- A. Be sure the machine is unplugged from any power source.
- B. Press the center locking pin on the side shield and slide the shield to the left. Then lift the side shield from the mounting pins on the base.
- C. Place the open end of the teardrop hole on the dust collection bin over the mounting pins.
- D. Slide the dust collection bin to the right until the center spring pin locks it into place.
- E. Repeat this installation on the other side of the machine.
- F. Now the machine can be plugged in to a power supply and used to sweep loose debris from the floor.
- G. The machine can be operated in a forward and backward motion.
- H. After use, remove the dust collection bins and empty debris.
- I. Reinstall the side shields or dust collection bins before resuming use.



**WARNING:** Be sure to keep loose carpets and cords from passing under the machine while in operation.



# MACHINE OPERATION

## 3. ENCAPSULATION CLEANING

Follow these steps for interim encapsulation cleaning of carpet:

- A. Start by removing large and loose debris. This can be done by installing the optional dust collection bins or with a vacuum.
- B. In a spray bottle or pump sprayer dilute the Betco® FiberCAP™ MP solution according to the directions on the bottle.



**WARNING: Always wear gloves to protect yourself from contact with hazardous chemicals.**



- C. Spray a light mist of solution onto the carpeted surface.
- D. If the optional dust collection bins were utilized, remove the dust collection bins on the machine and install the side shields.
- E. Turn on the machine and agitate the carpeted surface. Work in both a north-south direction as well as an east-west direction to ensure that all sides of the carpet fibers are agitated.
- F. The carpeted surface should dry in 20-30 minutes.
- G. Once dry, vacuum the carpet at the next scheduled service interval for that area.
- H. Repeat the process on a regular basis to maintain the best possible appearance of the carpet.



**WARNING: Be sure to keep loose carpets and cords from passing under the machine while in operation.**



# USE AND MAINTENANCE TIPS

## 1. REMOVAL OF BRUSHES AND CLEANING THE MACHINE

After each use, the brushes should be removed and cleaned. The underside of the machine should be cleaned as well.

- A. Disconnect the power supply from the machine.
- B. Lay the machine on the floor and pull the axle out from the center of the brush on the right side of the machine.
- C. Clean the brushes with jet-powered water.
- D. Clean the underside of the machine with a hand brush or cloth.
- E. Grease between the bearing, cover, and the bearing shaft entrance using white lithium grease.
- F. To install the brushes, simply slide the axle back through the center core of the brush until it locks into place on the left side of the machine.
- G. The brushes should be replaced once the overall bristle to bristle diameter is less than 2.75”.



**WARNING:** Carry out all maintenance operations with the power cord unplugged from the wall outlet.

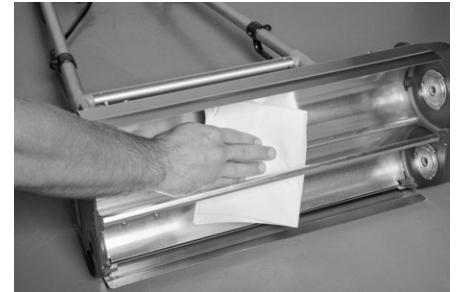

## 2. MACHINE LUBRICATION

- A. Disconnect the power supply from the machine.
- B. Remove the bearing cover monthly and clean using WD40 and then dry thoroughly using compressed air.
- C. Every 3 months, remove the gear cover, clean the gears with WD40, and regrease the gears with white lithium grease.
- D. Reinstall the bearing cover and gear cover before resuming operation.

## 3. MOTOR SAFETY SWITCH

- A. The safety switch automatically cuts off the electricity when the motor overloads.
- B. Should this happen, disconnect the power supply, wait 30 seconds, and press the button inwards to reset the safety switch.
- C. Then reconnect the power supply and continue working.
- D. If the safety switch continually trips, cease operation and please contact your Authorized Betco Distributor or Retailer.



# MACHINE DIAGRAM PARTS LISTING

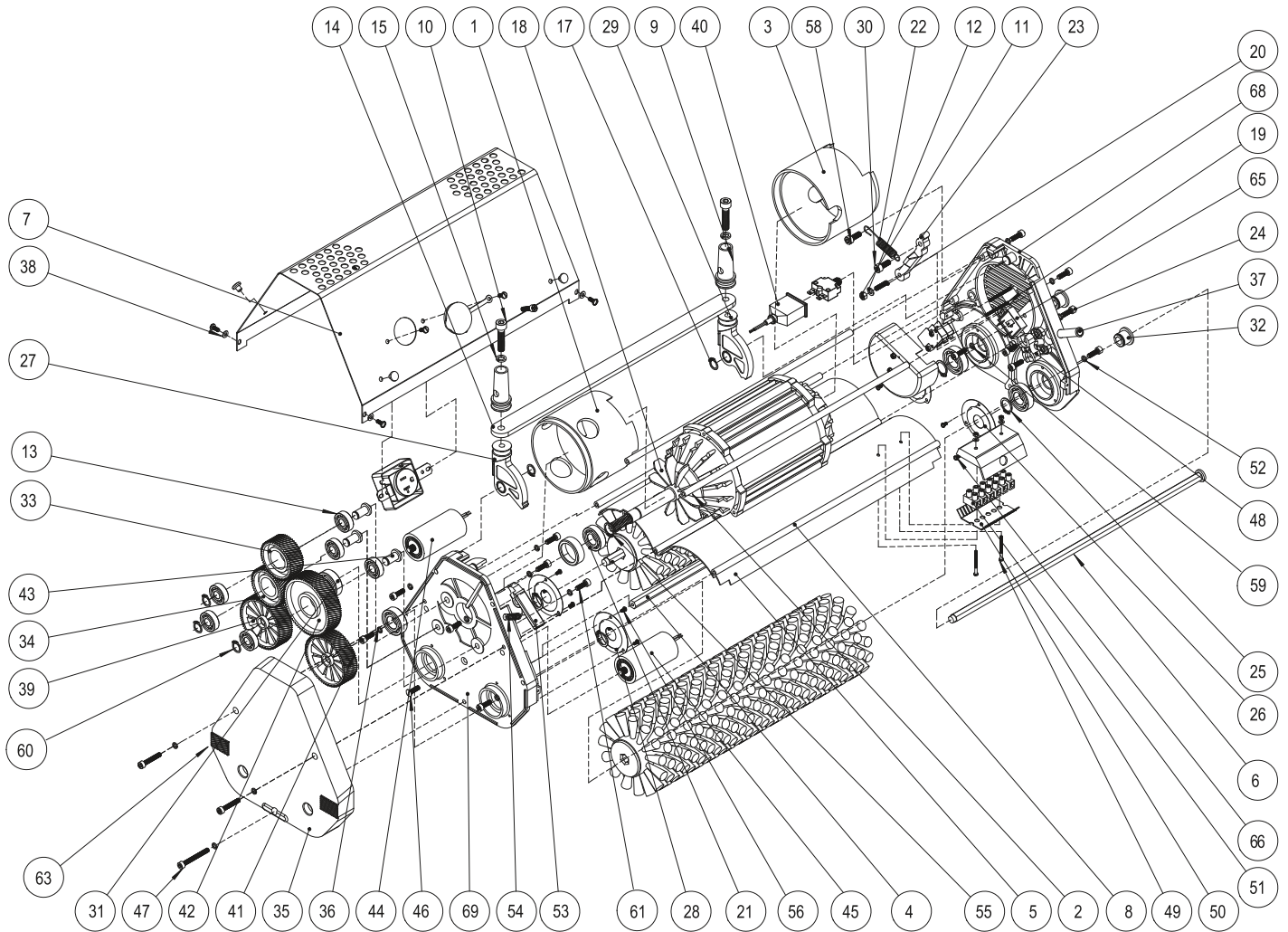

# MACHINE DIAGRAM PARTS LISTING

Item#	Part#	Description
1	E13190	Spacer, Motor
2	E13191	Motor, 1.0 HP
3	E13192	Spacer, Motor
4	E13194	Stud, Motor
5	E13195	Cover, Brush
6	E13196	Axle, Brush
7	E13197	Cover, Motor
8	E13198	Cover, Cable
9	E13199	Connector, Upper Handle
10	E13203	Screw, M8 x 25
11	E13209	Nut, Self-Locking, M5
12	E13210	Washer, M5
13	E13211	Bearing, 6000
14	E13213	Flat Bar
15	E13215	Ring, Spring
16	E13216	Plate, Isolation
17	E84600	Ring, Snap
18	E84603	Fan, Motor
19	E84605	Screw, Worm, M3 x 44
20	E84606	Screw, M5 x 20
21	E84607	Bearing, 6002 2RZ
22	E84610	Spring, Extension
23	E84611	Lever, Switch
24	E84612	Screw, M5 x 16
25	E84613	Ring, Retaining
26	E84614	Protective Plate
27	E84618	Connector, Handle, Lower G
28	E84619	Protective Plate
29	E84620	Connector, Handle, Lower E
30	E84621	Screw, M6 x 16
31	E84622	Bearing, 6003
32	E84623	Flange
33	E84624	Gear, 48, Right
34	E84625	Gear, 48, Left
35	E84626	Cover, Gear

Item#	Part#	Description
36	E84627	Washer, Lock, M5
37	E84629	Grommet
38	E84630	Screw, M4 x 12
39	E84631	Gear, 66, Right
40	E84632	Circuit Breaker
41	E84635	Gear, 66, Left
42	E84636	Gear, 73, Right
43	E84637	Stud, Bearing
44	E84638	Capacitor, Start, 22 MFD
45	E84639	Capacitor, Run, 145 MFD
46	E84640	Screw, M5 x 30
47	E84641	Screw, M5 x 45
48	E84644	Clamp, Cable
49	E84645	Screw, M3 x 16
50	E84646	Plate, Wire Fixing
51	E84647	Wire Terminal, EKL1
52	E84650	Washer, Lock, M4
53	E84652	Handle Stop
54	E84653	Spring, Handle Stop
55	E84654	Ring, Snap
56	E84657	Screw, M3 x 6
57	E84658	Pin, Locking
58	E84664	Screw, Pan Hd Phil, M6 x 14
59	E84665	Spring Ring
60	E84667	Ring, Snap
61	E84668	Screw, M6 x 14
62	E84669	Screw, M5 x 30
63	E84681	Bumper, Rubber
64	E84683	Cord, Pigtail
65	E84685	Microswitch
66	E84686	Nut, M3
67	E84687	Spring Ring, M3
68	E84691	Housing Unit E, Complete
69	E84692	Housing Unit G, Complete

## HANDLE DIAGRAM PARTS LISTING

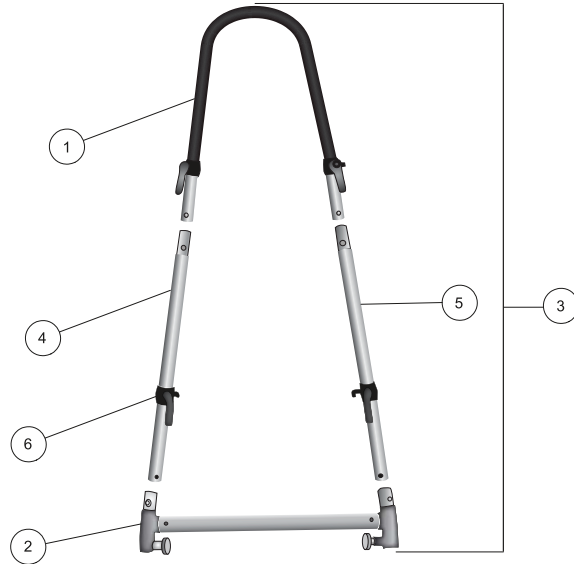

Item#	Part#	Description
1	E13200	Handle Bar, Upper Section
2	E13201	Handle Base Cross Bar
3	E13214	Handle Complete

Item#	Part#	Description
4	E84670	Handle Tube, Lower Left
5	E84671	Handle Tube, Lower Right
6	E84677	Hook, Cord Wrap



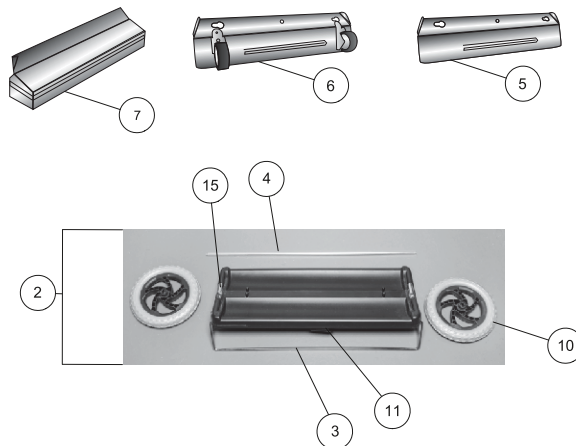

## ACCESSORIES DIAGRAM PARTS LISTING



Item#	Part#	Description
1	E13189	Tray w/ Clips
2	E13193	Storage Trolley, Complete
3	E13204	Support, Trolley
4	E13205	Axle, Trolley
5	E13206	Cover, Side, without Wheels
6	E13207	Cover, Side, with Wheels
7	E13208	Dust Bin, Sweeping
8	E13217	Pins, Plastic, Trolley

Item#	Part#	Description
9	E84673	Bolt, Dust Bin
10	E84678	Wheel, Trolley
11	E84679	Belt, Velcro, Trolley
12	E84680	Cover, Wiring
13	E84682	Cover, Wiring
14	E84690	Cord, Extension, 50'
15	E84696	Bracket, Trolley

# BRUSH OPTIONS

Part Number	Description	Appearance
E13226	Brush, Cylindrical, 15" White, Extra Soft (Carpet)	
E13227	Brush, Cylindrical, 15" Grey, Residential (Carpet)	
E13228	Brush, Cylindrical, 15" Blue, General Purpose (Carpet)	
E13229	Brush, Cylindrical, 15" Green, Medium Duty (Hard Surface)	
E13230	Brush, Cylindrical, 15" Yellow, Heavy Duty (Hard Surface)	

# ELECTRICAL WIRING DIAGRAM

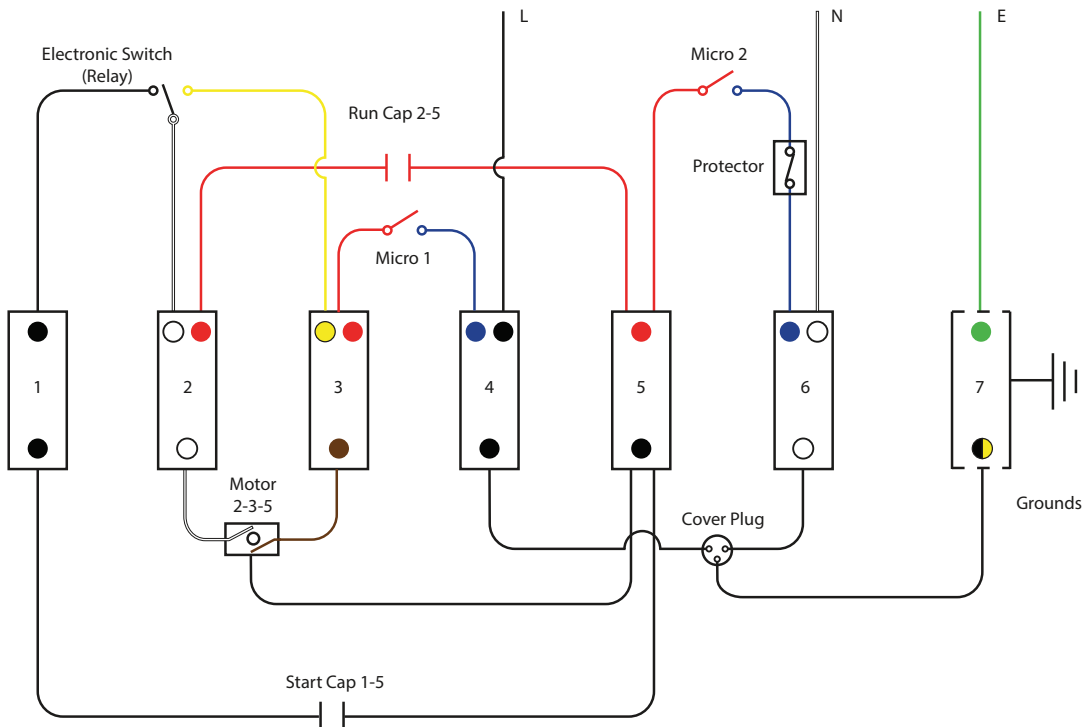

# BETCO US WARRANTY POLICY

## 10 year coverage

Subject to the conditions stated below, Betco warrants parts and labor on rotationally molded polyethylene tanks/ housings and injection molded vacuum head assemblies to be free from defects in materials and workmanship for a period of ten years to the original purchaser.

## 3 Year Coverage

Subject to the conditions stated below, Betco warrants parts and labor on all other Betco components to be free from defects in materials and workmanship for a period of three years to the original purchaser.

- Lithium Ion battery for MotoMop™ is a full 3 years

## 1 Year Coverage

Subject to the conditions stated below, Betco offers a limited warranty on parts and labor on the following equipment: parts and accessories to be free from defects in materials and workmanship for a period of one year to the original purchaser.

- PowerUp™ 14 Upright Vacuum: #E29990-00
- Bac Pac Lite Vacuum: #85903-00
- FiberPRO® Floor Dryer: #85507-00
- WORKMAN™ Series Vacuums: #85024-00, #85025-00, #83012-00, #85027-00
- All Tools and Accessories
- All Battery Chargers
- Deep cycle batteries are pro-rated for 1 year

### **Allowable Travel Time Warranty Reimbursement:**

Eligible equipment: All battery and propane powered equipment products. Warranty period: 90 days from date of sale to the original purchaser. A maximum 180 mile round trip at 50 cents per mile will be allowed for warranty consideration.

### **Propane Machine Warranty:**

Kawasaki/Subaru engines are warranted by Kawasaki/Subaru for a period of 2 years against manufacturer defects. All other components (except wear items)\* are warranted by Betco for a period of 3 years.

**\*Wear Items exempt from Warranty consideration include but may not be limited to: power cords, transport wheels, vacuum bags, belts, squeegee blades, pad drivers, clutch plates, handle grips, filters, screens, throttle cables, brushes and carbon brushes.**

Subject to the conditions and exceptions stated in this warranty, Betco warrants the Betco products to be free from defects in material and workmanship, under normal use and service, for the periods listed under the warranty policy to the original purchaser. At any time during the warranty period, Betco will furnish replacement parts for the Betco parts to the original purchaser. Such parts will be furnished and charged including transportation costs, to the original owner through any Betco authorized Service Distributor. If the original part is returned within the warranty policy period from date of delivery for inspection by Betco and is found to be defective the owner will be credited for the cost of replacement parts plus shipping and handling. Replacement parts that have become defective through wear or abuse are not included in this warranty.

This warranty does not apply to damage or defect caused by accident, misuse, Negligence, fire, or to any Betco product which has been serviced or repaired by other than an authorized Betco Service Distributor or Betco factory personnel. This warranty is void if products are used for any purpose other than that which was intended. There are no other warranties expressed or implied. In no event shall Betco be liable for incidental or consequential damages or any damage to person or property. (Please note some states do not allow the exclusion or limitations for incidental and consequential damages).

