



Electronic Service Manuals

This electronic document is provided as a service to our customers. We do not create the contents of the information contained in this document. Should you have detailed questions pertaining to the information contained in this document, you may contact Michco, or the manufacturer which provided the original information in this electronic deliverable. Michco's only part in this electronic deliverable was the electronic assembly process. By providing this manual on line we are not guaranteeing parts availability.

You may contact Michco through the following methods:

Phone (517) 484-9312 or (800) 331-3339

2011 N. High St. -- Lansing, Michigan -- 48906

Fax: (517) 484-9836

Email: CustServe@Michco.com

Web site: www.Michco.Com

Parts Web site: www.FloorMachineParts.Com

Order Parts on Line at:

www.FloorMachineParts.Com

Directly to Parts & Service:

By Email: **Shop@Michco.com**

By Fax: (517) 702-2041

By Voice: Use numbers above.

Serving the Cleaning Industry Since 1922

Notice: All copyrighted material remains property of original owners, all trademarks are property of respective owners. Manuals are subject to Manufacturer's reproduction limitations. Originals or reproductions were provided by manufacturers through a request. We make no warranty as to the correctness of information provided in this document and you assume all risk. By placing these manuals on line we are not declaring our corporation to be an manufacturer authorized dealer or provider, please check our web site for authorized manufacturers we represent.



E87026-00
E88064-00



STEALTH™ ASD26BT

26" Automatic Scrubber
with Traction Drive



Operator and Parts
Manual

TABLE OF CONTENTS

RECEIVING THE MACHINE.....	3 - 4
GENERAL SAFETY REGULATIONS.....	5
MACHINE PREPARATION.....	6 - 12
OPERATION	13 - 14
TURNING OFF THE MACHINE	15
DAILY MAINTENANCE.....	16 -17
WEEKLY MAINTENANCE.....	18
TROUBLESHOOTING	19
BRUSH AND SELECTION USE.....	19
PARTS DIAGRAMS AND LISTINGS.....	20 - 44
ELECTRICAL SYSTEM.....	44
BATTERY CHECK CARD – HOUR METER.....	45
WATER PLANT INSPECTIONS	45
BRAKE ADJUSTMENT.....	46
VACUUM SYSTEM INSPECTION	46
BRUSH ADJUSTMENT	47
SQUEEGEE ADJUSTMENT	48
CHECK LIST	49
MAINTENANCE SCHEDULE.....	50
WEAR ITEMS	51
WARRANTY	52

RECEIVING THE MACHINE

Immediately check, when receiving the machine, that all the materials indicated on delivery documents have been received and also that the machine has not been damaged in transit. If it has been damaged, this damage must be immediately reported to the shipper and also to our customer's service department. Only acting promptly in this manner will make it possible to receive missing material and to be compensated for damage.

INTRODUCTION

This is an automatic scrubber which, via the mechanical action of the rotating brush and the chemical action of a water/detergent solution, can clean many types of hard flooring. As it advances, it also collects the dirt removed and the detergent solution not absorbed by the floor.

The machine must be used only for this purpose. Even the best machines will only work well if used correctly and kept in good working order. We therefore suggest you read this instruction booklet carefully and re-read it whenever difficulties arise while using the machine. Please contact our technical service department or your dealers if you have any questions about the machine.

Serial # Plate

Production Year	Power Source		Battery Weight (L)
2009	24 Volt DC		132 lbs
Max. Sp. Load	Power Consumption		Machine Weight
10%	53 Amps		255 lbs
Model Name		Part Number: E87805-00	
STEALTH ASD26BT		S/N <input type="text"/>	

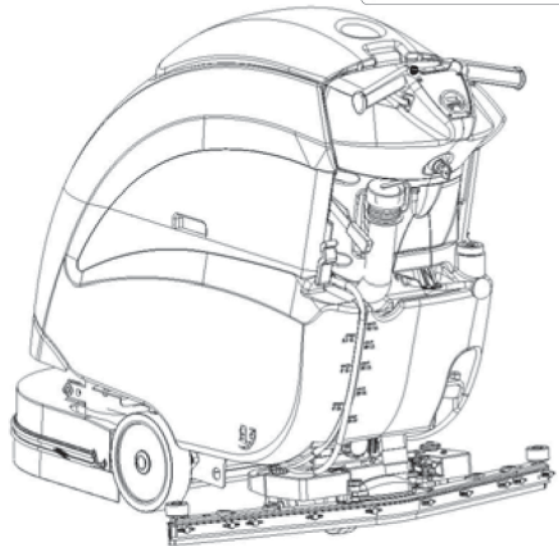

SYMBOLS USED ON THE MACHINE



Solution valve symbol
Used to indicate the water regulation switch



Battery charge gauge



Battery symbol



Open book symbol
Used to tell the operator to read the manual before using the machine



Maximum solution temperature gauge
Located near the solution tank inlet

TECHNICAL DESCRIPTION	Measurement Unit	Stealth™ ASD26BT
Rated power	HP (W)	1.7 (1260)
Working width	In (mm)	26 (660)
Rear squeegee width	In (mm)	37.3 (948)
Work capacity	ft ² /h (m ² /h)	31,970 (2970)
Brush & Pad (diameter)	in (mm)	13 (330)
Brush RPM	RPM	225
Brush pressure	lb. (Kg)	99.2 (45)
Brush motor	V / HP (V / W)	24 / 0.75 (24 / 560)
Drive Type		Automatic
Traction motor	V / HP (V / W)	24 / 0.20 (24 / 150)
Forward movement speed	mph (km/h)	0 - 1.9 (0 - 3)
Maximum grade		10%
Vacuum motor	V / HP (V / W)	36 / 0.74 (36 / 550)
Vacuum motor suction	inches of water (mbar)	75.6 (192)
Solution tank capacity	Gal (l)	16 (60)
Recovery tank capacity	Gal (l)	19 (72)
Weight of machine (excluding batteries)	lb. (Kg)	253.5 (115)
Batteries	V / Ah	12 / 155 (2)
Charger	V / A	24 / 12
Battery compartment dimensions (Length / Height / Width)	in x in x in	13.8 x 12.0 x 14.2
	(mm/mm/mm)	(350 / 305 / 360)
Machine dimensions (Length / Height / Width)	in x in x in	54.3 x 41.5 x 26.8
	(mm/mm/mm)	(1380 / 1053 / 680)
Noise level	dB(A)	58

GENERAL SAFETY REGULATIONS

The regulations below must be carefully followed in order to avoid harm to the operator and damage to the machine.

- Read all labels on the machine carefully. Do not cover them for any reason and replace them immediately if they become damaged.
- The machine must be used exclusively by authorized and trained personnel.
- When operating the machine be careful of other people.
- The machine is not designed for cleaning carpets.
- The power cable outlet must be provided with a proper ground.
- Avoid damaging the power cable of the battery charger by crushing, bending, cutting or stressing it.
- Whenever the power cable of the battery charger is damaged, immediately contact a BETCO service center.
- Do not mix different types of detergent as this may produce harmful gases.
- Do not set containers on the machine.
- Machine storage temperature is between -10°F and 130°F, never store outside under humid conditions.
- Operating conditions: room temperature between 33°F and 100°F with relative humidity between 30% to 95%.
- Only use the machine in closed areas and do not expose it directly to rain.
- Never use the machine in an explosive environment.
- Do not use the machine as a means of transport.
- Never use acidic chemicals which could damage the machine.
- Avoid running the brushes with the machine stopped; this could damage the floor.
- Never vacuum up flammable liquids.
- Never use the machine to gather dangerous powders.
- Use a powder fire extinguisher in case of fire. Do not use water.
- Do not hit against shelving or scaffolding. The operator must always be equipped with the appropriate safety device (gloves, shoes, helmet, glasses, etc.)
- Do not use the machine on surfaces with an inclination greater than the one shown on the serial plate.
- The machine is designed to wash and dry floors simultaneously. Signal the presence of wet floors with suitable signs.
- If the machine does not work properly, perform routine maintenance. Otherwise, request the assistance of the BETCO technical service.
- When replacing parts ask for ORIGINAL spare parts from your Authorized BETCO Dealer and/or Retailer.
- Always turn off the machine and disconnect the battery connector whenever maintenance is performed.
- Never remove guards that require tools for removal.
- **Never wash the machine with direct or pressurized jets of water or with corrosive substances.**
- Have your BETCO service center check the machine once a year.
- To prevent the formation of scale in the solution tank filter, do not store the machine with detergent solution in the tanks.
- Before using the machine make sure that all doors and covers are positioned as shown in this operating and maintenance manual.
- When your BETCO machine is ready to be retired, the machine must be disposed of properly. It contains oils and electronic components. The machine was built using totally recyclable materials.
- Use only brushes furnished with the machine or those specified in the user's manual. Use of other brushes can compromise safety.
- When removing the battery, unplug the battery connection, unplug the charger and disconnect the battery terminals.
- Before recycling the machine, remove the battery.

MACHINE PREPARATION

1. HANDLING THE PACKED MACHINE

The machine is contained in specific packaging.

It is not possible to place more than two packages on top of each other.

The total weight is 253.5 lbs. (115 kg).

The overall dimensions of the package are:

A : 49.6 in (1260 mm)

B : 28.4 in (720 mm)

C : 65.4 in (1660 mm)

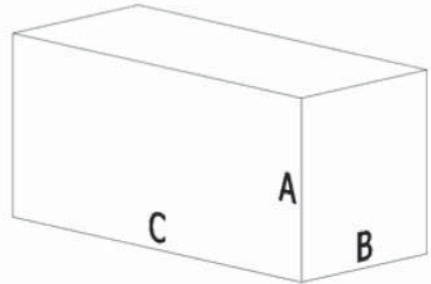

2. HOW TO UNPACK THE MACHINE

A. Remove the outer packaging.

B. The machine is attached to the pallet with wedges which block the wheels.

C. Remove these wedges.

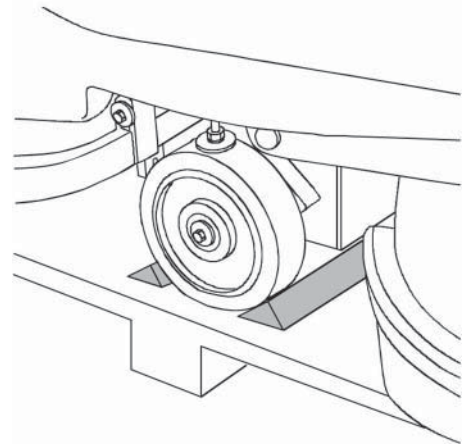

D. Use a ramp to get the machine down from the pallet, pulling it backwards.

E. Keep the pallet for any future transport needs.

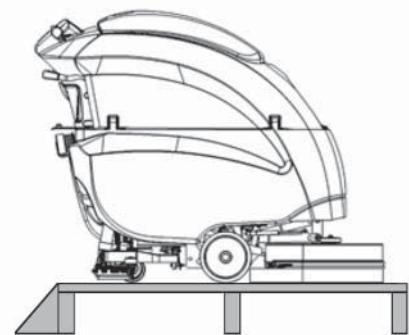

MACHINE PREPARATION

3. BATTERY INSTALLATION

The machine will be supplied with a battery charger and either two 12 V Wet or AGM batteries. The batteries must be housed in the battery tray in the battery compartment beneath the recovery tank.

To insert the batteries you must:

- A. Lower the squeegee and base.
- B. Open the rear latch that secures the tank (2).
- C. Rotate the recovery tank as far as it will go, using the side handle (3).



WARNING: To avoid acid spillage you can use sealed batteries.

WARNING: Perform one battery charging cycle before using the machine.

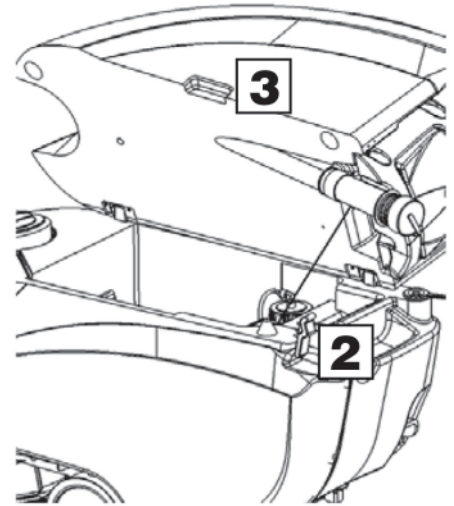

4. TYPE OF BATTERY

To power the machine you can use:

- Wet batteries
- AGM batteries
- Gel batteries

OTHER TYPES MUST NOT BE USED.

The maximum dimensions and weight are:

- Width 6.8 in. (172 mm)
- Length 14.2 in. (360 mm)
- Height 11.2 in. (285 mm)
- Weight 97 lb. (44 kg)



WARNING: Your charger must be set according to the type of battery you install. Call BETCO customer service to ensure correct charger setting after replacement batteries are installed.

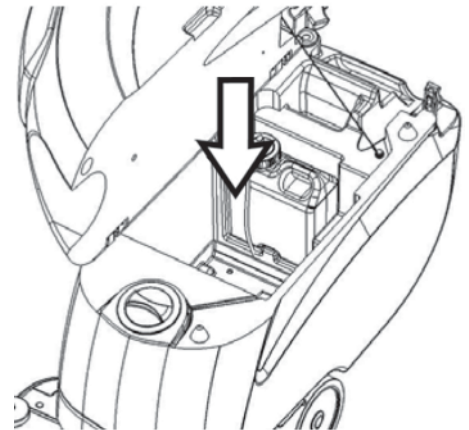

- The batteries must be handled using lifting and transportation means suitable for the weight and dimensions.
- They must be lifted by the handles on the upper part.
- They must be connected together in series, to obtain an overall voltage of 24 V on the lugs.
- The electrical connection operations must be carried out by certified trained personnel.

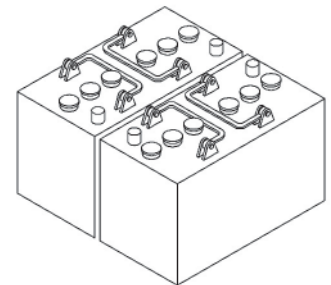

MACHINE PREPARATION

5. BATTERY MAINTENANCE

For maintenance and recharging, follow the instructions provided by the battery manufacturer.

6. BATTERY DISPOSAL

When the battery reaches the end of its life, it must be disconnected by certified professional, then lifted (using the handles and suitable lifting device) to remove it from the battery compartment.

7. CONNECTING THE BATTERY CHARGER

Beneath the recovery tank there is the battery connector (7), the battery charger connector must be plugged into. Disconnect the battery plug and plug the charger into the machine plug.



WARNING: This process must be carried out by qualified personnel. The incorrect or imperfect connection of the cables to the connector can seriously harm people and damage objects.

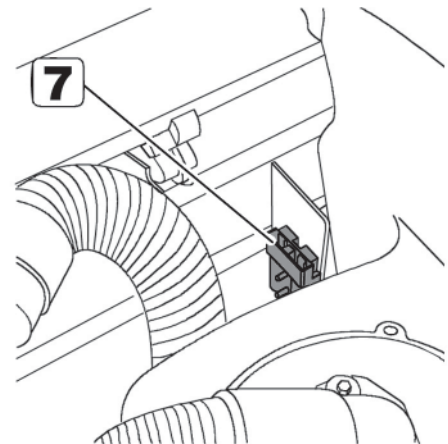

8. RECHARGING THE BATTERIES

Perform one complete battery charge cycle before using the machine. Avoid totally discharging the batteries! This can cause permanent damage. Recharge as soon as the battery discharged signal light starts to flash.



WARNING: Never leave the batteries completely discharged, not even if the machine is not being used. This can cause permanent damage to them. While recharging, keep the recovery tank raised.



Danger of inhalation of gas and leakage of corrosive liquids.



Danger of fire.

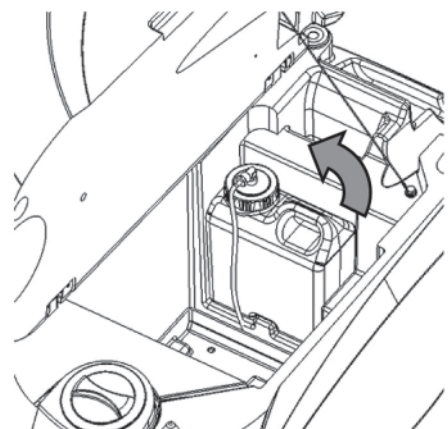

MACHINE PREPARATION

9. CONNECTING THE BATTERY CONNECTOR

Connect the battery connector (2) to the machine connector (1)

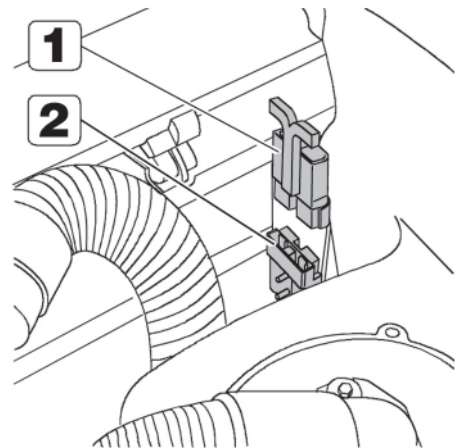

10. BATTERY INDICATOR

The battery indicator uses LEDs and has 8 positions (7 yellow - charged batteries, and 1 red - run down batteries).



WARNING: A few seconds after the red indicator light comes on, the brush motor turns off automatically. The vacuum motor will remain in operation so that the remaining water can be removed from the floor.

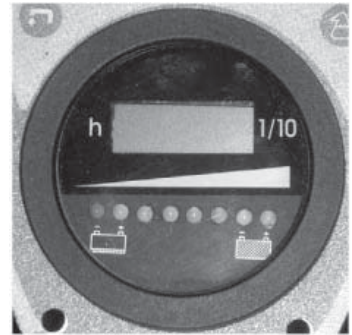

MACHINE PREPARATION

11. INSTRUMENT PANEL COMPONENTS

The instrument panel components are identified as follows:

- A. Paddles to activate brushes / traction (located beneath the grip)
- B. ON/OFF key switch
- C. Battery level / hour meter

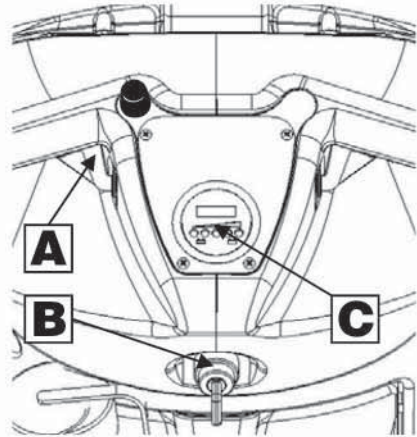

12. REAR COMPONENTS

The rear components are identified as follows:

- A. Pedal to raise the brushes
- B. Water level tube
- C. Solution tank water inlet cap
- D. Drain hose of recovery tank
- E. Latch to lock down the recovery tank
- F. Storage compartment
- H. Lever to raise the squeegee
- I. Brake lever
- J. Solution filter

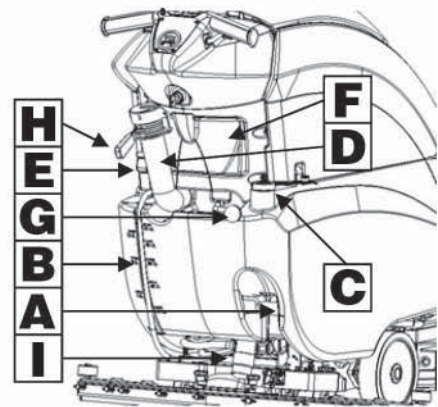

13. SIDE COMPONENTS

The side components are identified as follows:

- A. Solution flow control valve
- B. Handle to raise the recovery tank
- C. Handle to raise the vacuum unit
- D. Upper storage compartment

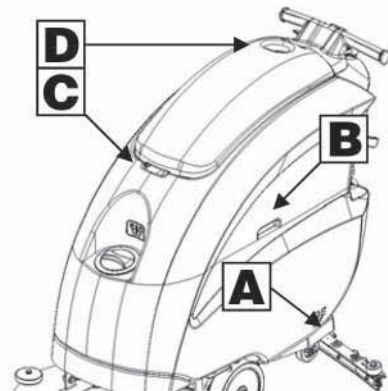

14. ASSEMBLING THE SQUEEGEE

For packaging reasons, the squeegee is supplied disassembled from the machine, and must be assembled as shown in the figure, inserting the small pin of the squeegee into the coupling mechanism until it locks into place.

Install the squeegee vacuum hose over the squeegee shoe adapter and be certain that the vacuum hose in to the right of the squeegee lift cable.

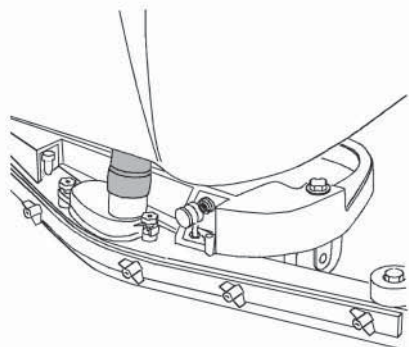

MACHINE PREPARATION

15. ADJUSTING THE SQUEEGEE HEIGHT

The height of the squeegee must be adjusted based on wear of the squeegee. To do this, turn the knob (2) counter clockwise to raise the squeegee, and clockwise to lower it.

Note: the right and left wheels must be adjusted to the same level, so the squeegee works parallel to the floor.

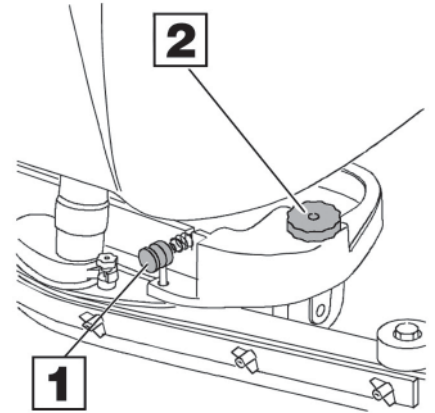

16. ADJUSTING THE SQUEEGEE INCLINATION

During working operation, the rear squeegee blade is slightly bent backwards (by about 0.2 in (5 mm)) uniformly over its entire length. If it's necessary to increase the bend of the squeegee blade in the center, you must tilt the squeegee backwards, rotating the adjuster (1) counter clockwise. To increase the bend of the squeegee at the outside edges of the squeegee, rotate the adjuster clockwise. After adjustment, tighten the jam nut.

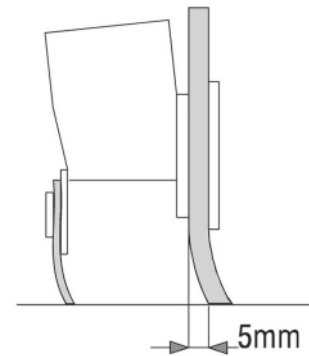

17. RECOVERY TANK

Check the drain hose cap (on the rear of the machine) to ensure it's closed.

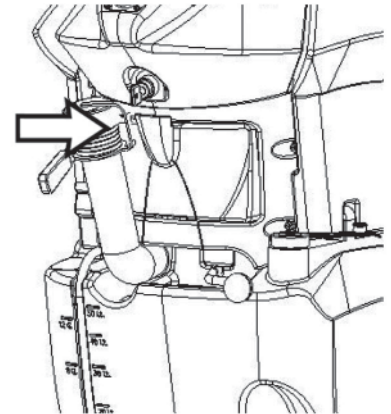

MACHINE PREPARATION

18. SOLUTION TANK

Remove the front inlet cap and check the solution filter is correctly installed. Check the solution filter cover (beneath the tank) is correctly closed.

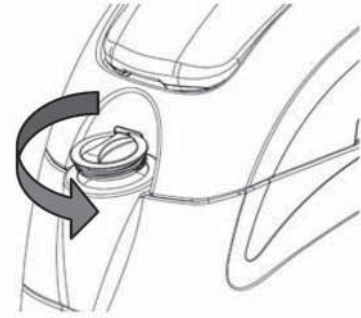

19. SOLUTION TANK

- Fill the tank with clean water in the front fill location (1) or at the rear fill location (2) at a temperature not exceeding 120°F (50°C).
- You can check the level of solution in the tank by means of the rear sight gauge (3).
- Add the liquid detergent into the tank, in the concentration and manner specified by the manufacturer. The formation of excess foam could damage the vacuum motor, so be sure to use only the correct amount of detergent.



WARNING: Always use low-foam detergent. Introduce a small amount of defoaming liquid in the recovery tank before starting to work to prevent foam from being generated.

WARNING: Never use pure acids.

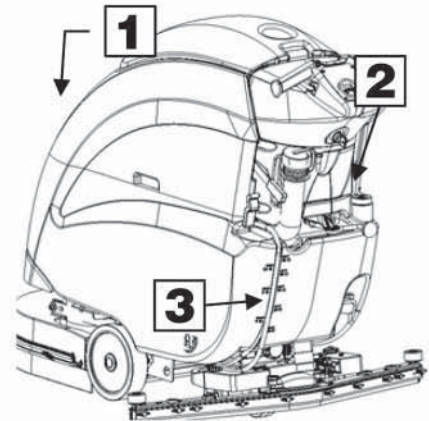

20. ATTACHING THE BRUSHES

A. With the brush deck up, insert the brushes in the brush housing beneath the deck base, turning them until the three pins enter the notches in the clutch plate; turn the brush until the pin is pushed towards the coupling spring and is locked into place. The figure shows the brush rotation direction for the right-hand brush; the left-hand brush rotates in the opposite direction.



WARNING: Make sure there are no objects or people in the vicinity of the brush when doing this operation.

B. Swap the right and left-hand brushes every day. If the brushes are used and have deformed bristles, it is better to reassemble them in the same position (the right-hand one on the right, and the left-hand one on the left), to prevent the deformed bristles overloading the brush motor as well as excessive vibration.

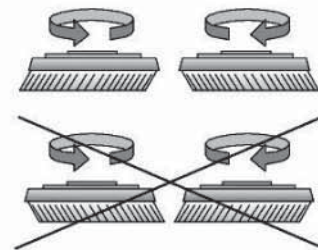
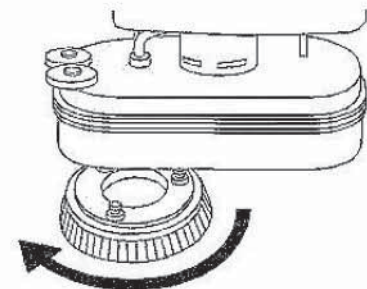

21. REGULATING THE SOLUTION

Regulate the quantity of water with the solution control valve (1).

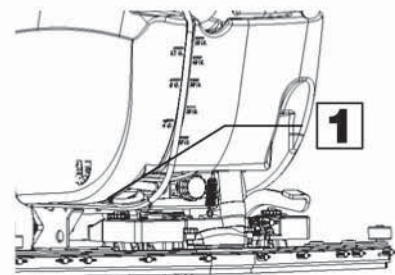

OPERATION

1. PREPARING TO WORK

A. Connect the battery plug (1) to the machine plug

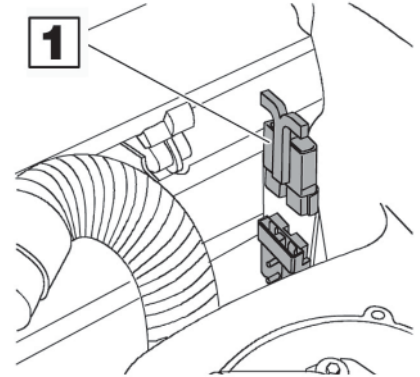

B. Turn the key (1) of the main switch to the "ON" position (clockwise). The battery charge level indicator lights will immediately come on.

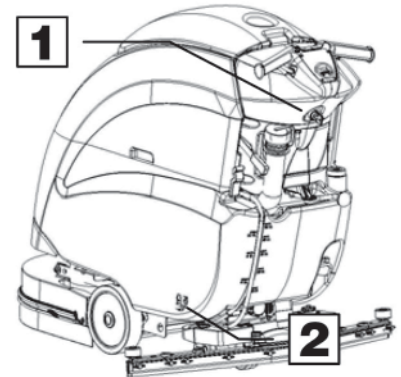

C. Turn on the solution control valve (2) (solution dispenses automatically while the brushes are turning).

D. Release the foot lever (3) and lower the brush deck. If the floor is particularly dirty, you can apply additional pressure to the brush deck by raising the foot lever (3) until the lock down is engaged.

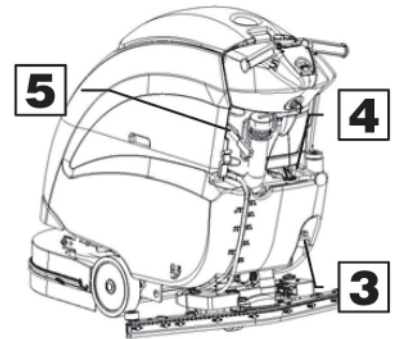

E. Lower the squeegee, turning the lever (4) counter clockwise. The vacuum motor will switch on.

F. Check that the brake (5) is released.

G. Pulling the switch levers (1), activates the brushes and the machine begins to move forward. During the first few feet, check that the amount of solution is correct, and that the squeegee dries the floor.

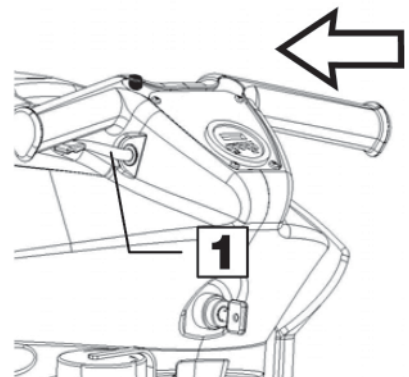

H. The machine will now start to scrub and dry until the solution tank is empty or recovery tank is full.

OPERATION

2. REVERSE MOVEMENTS

To move in the reverse direction, push the switch levers (1) forward.



WARNING: When making reverse movements, raise the squeegee.

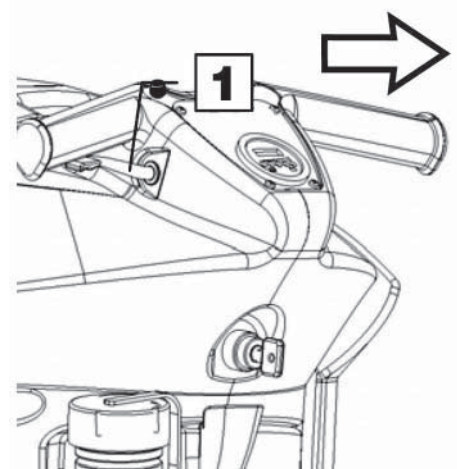

3. OVERFLOW DEVICE

The machine has a float in the filter basket that activates when the recovery tank is full and stops airflow into the vacuum.

You must empty the recovery tank by removing the cap of the rear drain hose.



WARNING: Always wear gloves when doing this operation to protect yourself from contact with hazardous chemicals.

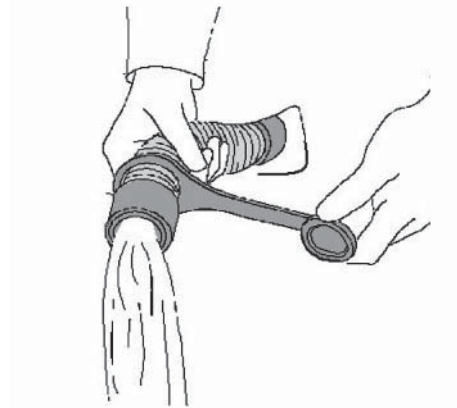

SHUTTING DOWN THE MACHINE

1. END OF WORK

When shutting down the machine and before you perform any type of maintenance:

- A. Turn off the solution control valve using the handle (1)
 - B. Raise the brush deck using the foot lever (2)
 - C. Raise the squeegee using the squeegee lift lever (3)
 - D. Turn off the key switch (4)
 - E. Move the machine where the tanks can be drained.
-
- F. Remove the drain hose from its holder, unscrew the drain cap and empty the recovery tank.
 - G. The squeegee must be raised when the machine is not operating, to avoid deforming the squeegee blade blades.
 - H. Remove the pads and clean them with water.



WARNING: Always wear gloves when doing this operation to protect yourself from contact with hazardous chemicals.

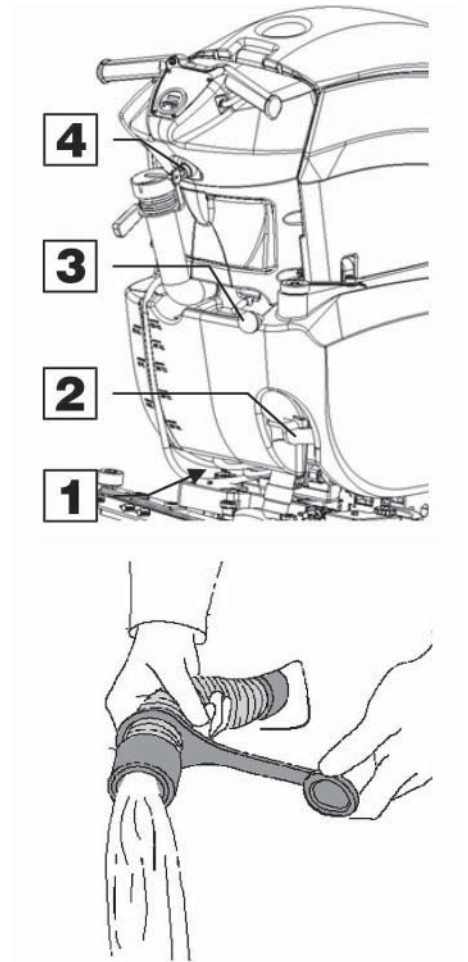

DAILY MAINTENANCE

1. CLEANING THE RECOVERY TANK

- A. Raise the vacuum unit (1).
- B. Remove the drain hose (2) and empty the tank.
- C. Rinse the inside of the tank with water.
- D. Close the vacuum unit on the machine and replace the drain hose cap and drain hose.



WARNING: Always wear gloves when doing this operation to protect yourself from contact with hazardous chemicals.

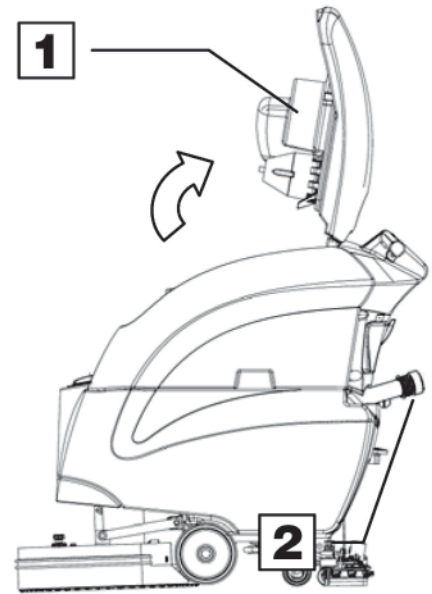

2. CLEANING THE VACUUM FILTER

- A. Raise the vacuum unit.
- B. Remove the vacuum filter cover by rotating it clockwise.
- C. Pull the filter straight down from the lid to remove it.
- D. Use water to clean the walls and base of the filter.
- E. Reassemble all the components.



WARNING: Always wear gloves when doing this operation to protect yourself from contact with hazardous chemicals.

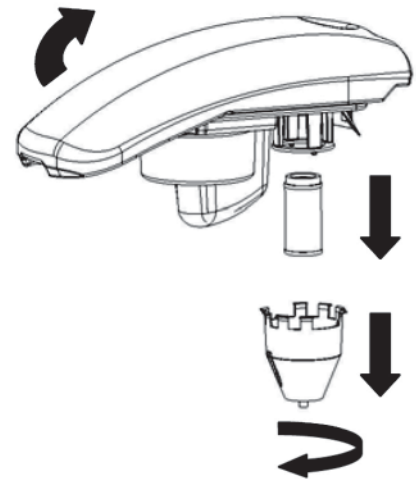

3. CLEANING THE VACUUM HOSE FILTER

- A. Raise the vacuum unit.
- B. Rotate the inner filter (1) and remove it.
- C. Use water to clean the walls and base of the filter.
- D. Reassemble all the components.



WARNING: Always wear gloves when doing this operation to protect yourself from contact with hazardous chemicals.

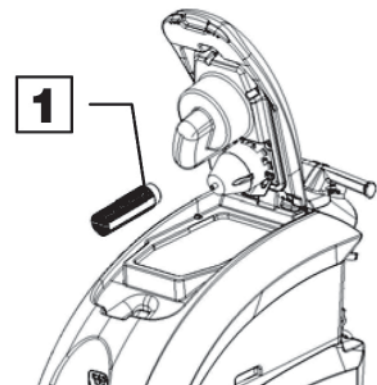

DAILY MAINTENANCE

4. CLEANING THE SQUEEGEE

Ensure the squeegee is always clean, to improve drying results.

To clean:

- A. Remove the squeegee vacuum hose from the squeegee shoe adapter.
- B. Remove the cotter pins that attach the pins of the squeegee shoe.
- C. Disassemble the squeegee from its support.
- D. Loosen the wing nuts (1).
- E. Remove the squeegee band clamp and squeegee blade.
- F. Replace the squeegee blades.

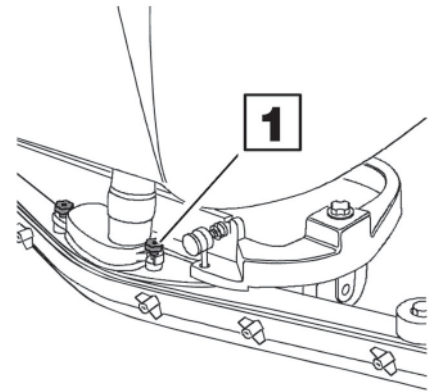

To reassemble the squeegee, repeat the operations in the reverse order.



WARNING: Always wear gloves when doing this operation to protect yourself from contact with hazardous chemicals.

5. REMOVING THE PAD DRIVERS

- A. Turn the key to the “off” position.
- B. Raise the brush deck using the foot lever.
- C. Rotate the brush until it comes out of the clutch as shown in the figure. The figure shows the rotation direction to release the right-hand brush; for the left-hand one, rotate in the opposite direction.



WARNING: Always wear gloves when doing this operation to protect yourself from contact with hazardous chemicals.

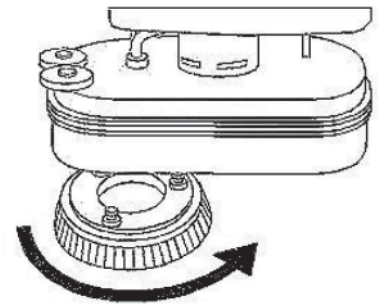

6. REPLACING THE SQUEEGEE BLADES

Check the state of wear of the squeegee blades and, if necessary, replace them.

To replace:

- A. Remove the squeegee hose from the squeegee shoe adapter.
- B. Push the release lever and release the right hand stud.
- C. Remove the squeegee vacuum from the squeegee yoke.
- D. Loosen the wing nuts.
- E. Remove the squeegee band clamp and squeegee blade.
- F. Replace the squeegee blades.

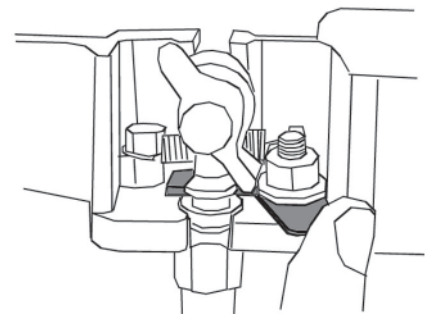

To reassemble the squeegee, repeat the operations in the reverse order.



WARNING: Always wear gloves when doing this operation to protect yourself from contact with hazardous chemicals.

WEEKLY MAINTENANCE

1. CLEANING THE SQUEEGEE HOSE

Every week, or whenever vacuum seems to be unsatisfactory, check the squeegee hose for obstructions. To clean:

- A. Remove the hose from the squeegee shoe adapter on the squeegee shoe.
- B. Remove the other end from the recovery tank.
- C. Wash the inside of the hose with water from the end of the hose which is connected to the recovery tank.
- D. Reassemble the hose.



WARNING: Always wear gloves when doing this operation to protect yourself from contact with hazardous chemicals.

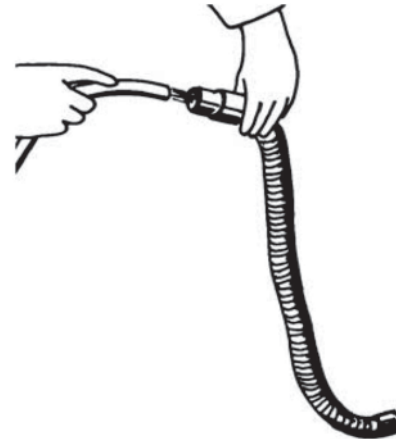

2. CHECKING THE BRAKE

Every week, check the distance between the brake pads and the wheels. If necessary, adjust them, so the pads are 0.12 inches away from the transport wheels at a distance of 0.12 in (3 mm) when released.

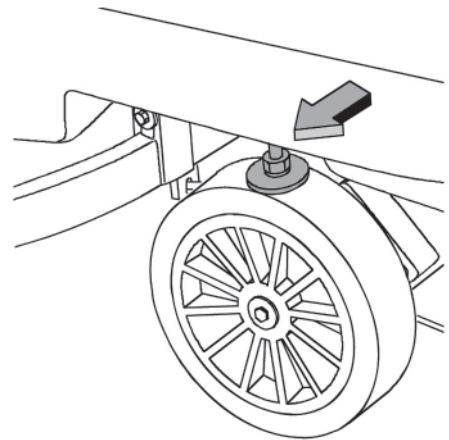

3. CLEANING THE SOLUTION TANK

- A. Loosen the solution tank cap.
- B. Rinse with water.
- C. Loosen the drain cap (1) located on the filter, and empty the tank.



WARNING: Always wear gloves when doing this operation to protect yourself from contact with hazardous chemicals.

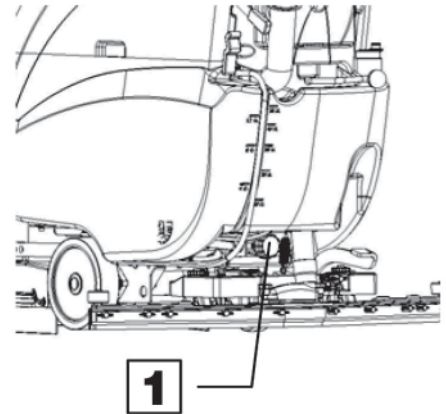

TROUBLESHOOTING GUIDE

INSUFFICIENT WATER ON THE PAD

1. Verify that the solution control valve – located beneath the symbol – (1) is turned on.
2. Verify that there is water in the solution tank.

THE MACHINE DOES NOT CLEAN WELL

1. Check the state of wear of the scrubbing pad and, if necessary, replace it.
2. Use a different kind of scrubbing pad.

THE SQUEEGEE DOES NOT DRY THE FLOOR

1. Ensure that the squeegee blades are clean.
2. Adjust the inclination of the squeegee.
3. Ensure the vacuum hose is correctly installed.
4. Check the inner filter of the recovery tank to ensure it is not dirty and, if necessary, clean it thoroughly.
5. Disassemble the entire vacuum unit and clean it.
6. Replace the squeegee blades, if worn.
7. Ensure the vacuum motor is turned on.
8. Check squeegee wheel adjustment.

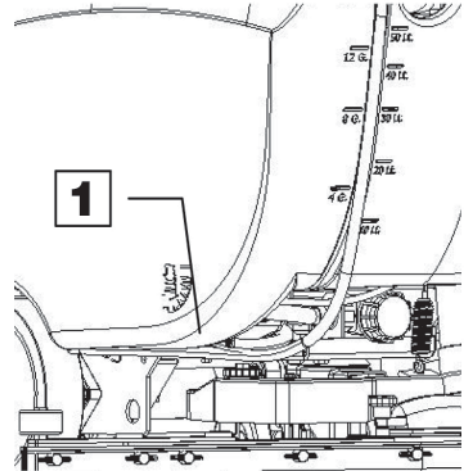

TOO MUCH FOAM IS GENERATED

Check that low-foam detergent is being used. If necessary add a small amount of defoamer liquid to the recovery tank. Remember that more foam is generated when the floors are not very dirty. Dilute the detergent more when cleaning floors that are not very dirty.

CHOOSING AND USING THE BRUSHES

POLYPROPYLENE BRUSH (PPL)

Used on all types of floors. Good resistance to wear and tear, and hot water (no greater than 140°F (60°C)).

NYLON BRUSH

Used on all types of floors. Excellent resistance to wear and tear and hot water (even over 140°F (60°C)).

ABRASIVE BRUSH

The bristles of this type of brush are coated with highly aggressive abrasives. It is used to clean very dirty floors. To avoid floor damage work only with the brush pressure necessary.

THICKNESS OF THE BRISTLES

Thicker bristles are more rigid and are therefore used on smooth floors or floors with small joints. On uneven floors or those with deep joints, it is advisable to use softer bristles which can enter the gaps easier. When the bristles are worn and too short, they will become rigid and are no longer able to penetrate and clean deep down and the brushes tends to jump.

PAD DRIVER

Pad Holders and scrub pads are recommended for cleaning smooth surfaces. There are two types of pad holder:

1. The traditional pad holder has a series of anchor points that allow the abrasive floor pad to be held and dragged while working.
2. The CENTER LOCK type pad holder not only has anchor points, but also a snap-type central locking system made of plastic that allows the abrasive floor pad to be centered and held without any risk of it becoming detached. This type of pad driver is recommended above all for machines with more than one brush.

BRUSH DECK DIAGRAM

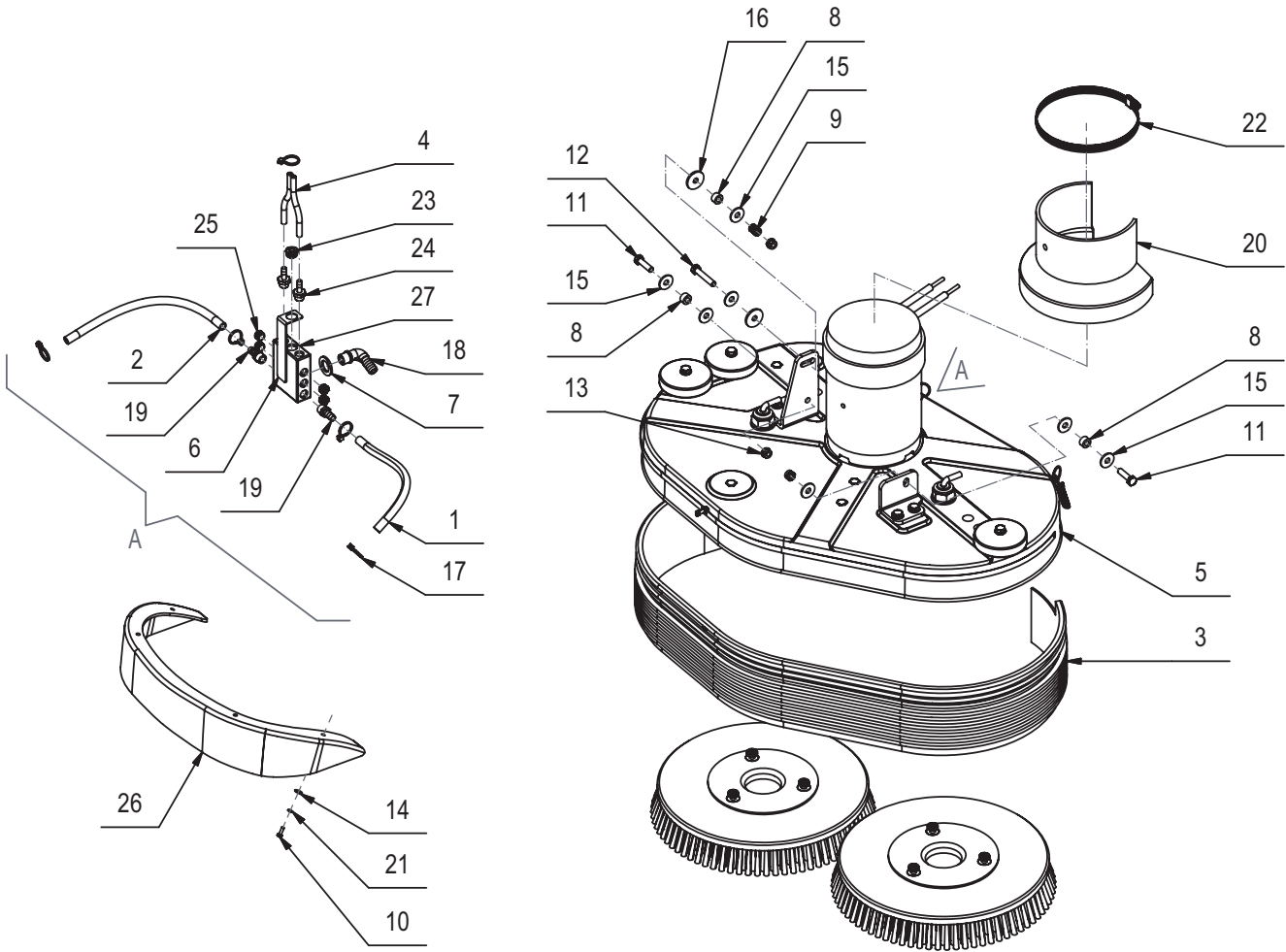

BRUSH DECK PARTS LISTING

Item#	Part #	Description	Qty.
1	E20476	Tubing 8 ID x 12 OD x 250 L	1
2	E20329	Tubing 8 ID x 12 OD x 300 L	1
3	E86143	Splash Guard	1
4	E82710	Hose, 8 OD x 5 ID x L 105	2
5	E20416	Brush Deck	1
6	E20628	Support Bracket	1
7	E20474	Flat Washer M18x30x3 Nylon	1
8	E83932	Bushing	3
9	E82309	Spring, Compression	1
10	E83857	Hex Bolt M4x12 Zinc	4
11	E83802	Hex Bolt M8x30 Zinc	2
12	E83827	Hex Bolt M8x45 Zinc	1
13	E81709	Nyloc Hex Nut, M8 Zinc	3
14	E83037	Flat Washer M4x12x1.6 Zinc	4

Item#	Part #	Description	Qty.
15	E83404	Flat Washer M9x24x2.5 Zinc	7
16	E83832	Flat Washer M8.5x30x3 Nylon	2
17	E83935	Hose Clamp	5
18	E86275	Barbed Elbow	1
19	E20481	Barbed Nipple	2
20	E20637	Brush Motor Cover	1
21	E20475	Lock Washer M4 Zinc	4
22	E20607	Hose Clamp	1
23	E20627	Cap	1
24	E81552	Fitting	2
25	E20581	Plug	4
26	E20187	Plug	1
27	E20631	Manifold	1

BRUSH DRIVE DIAGRAM

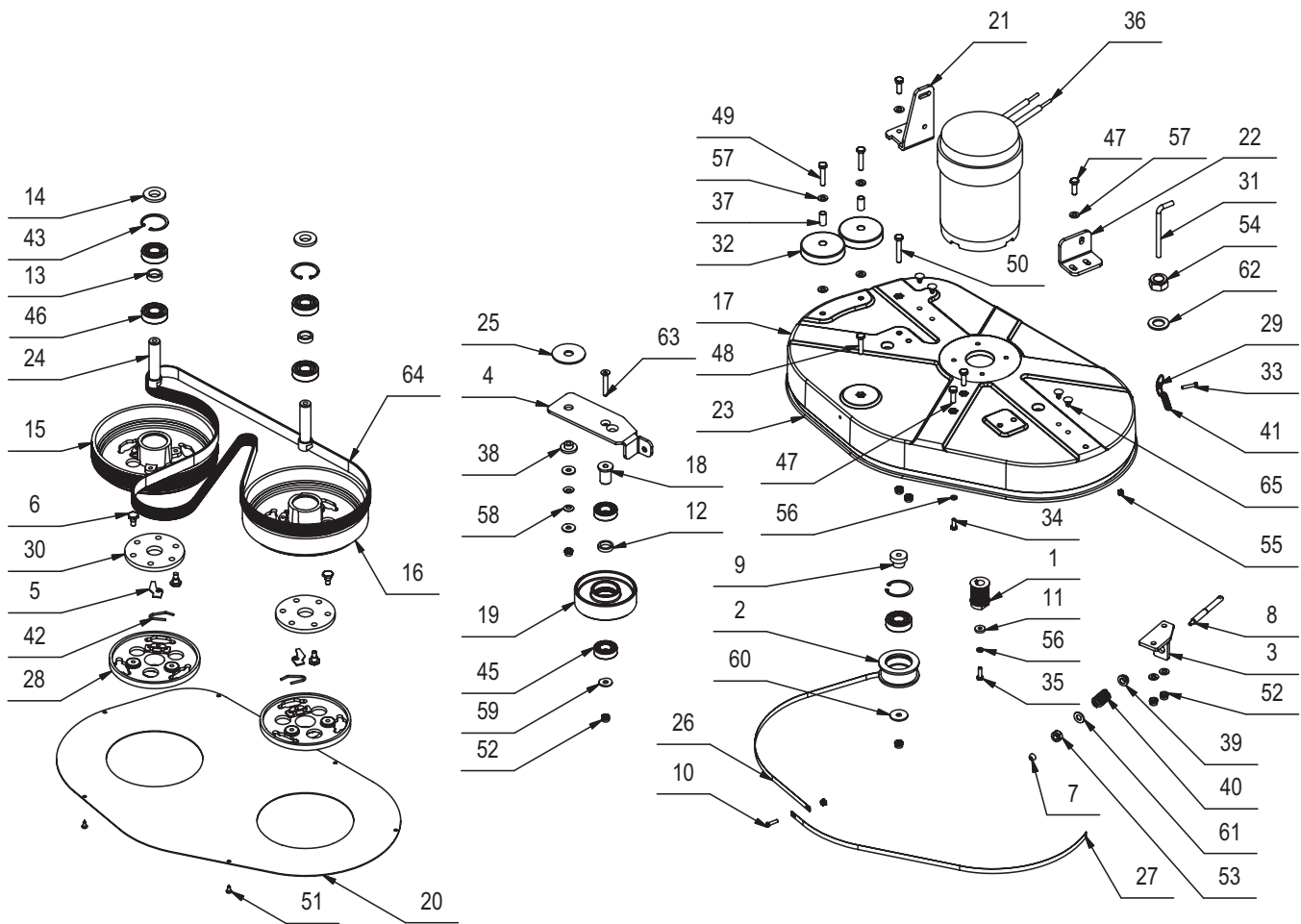

BRUSH DRIVE PARTS LISTING

Item#	Part #	Description	Qty.
1	E82424	Motor Pulley	1
2	E85723	Idler Pulley	1
3	E20428	Tensioner Bracket	1
4	E20491	Tensioner Arm	1
5	E81957	Pad Driver Retainer Clip	2
6	E20007	Stud Bolt	12
7	E88009	Bushing	1
8	E88008	Adjuster	1
9	E87279	Bushing	1
10	E83823	Screw M5x20/ SS Custom	1
11	E20615	Flat Washer M6.5x18x4	1
12	E20546	Spacer	1
13	E86216	Spacer	2
14	E87281	Spacer	2
15	E20517	Brush Pulley	1
16	E20508	Brush Pulley	1
17	E20564	Brush Deck	1
18	E20311	Bushing	1
19	E20622	Idler Pulley	1
20	E20419	Brush Deck Cover	1
21	E20624	Brush Deck Lift Bracket	1
22	E20061	Brush Deck Lift Bracket	1
23	E20335	Sheath	1
24	E87284	Shaft	2
25	E88110	Flat Washer M6.1x60x3 Nylon	1
26	E81926	Band Clamp	1
27	E81926	Band Clamp	1
28	E20535	Clutch Plate	2
29	E83489	Rings	2
30	E20229	Flexible Coupling	2
31	E82303	Pipe	2
32	E83895	Wheel 80 OD x 23 W	3

Item#	Part #	Description	Qty.
33	E20086	Hex Bolt M5x25 Zinc	2
34	E83547	Hex Bolt M6x16 Zinc	4
35	E82772	Hex Bolt M6x20 Zinc	1
36	E82738	Brush Motor 24VDC 560W	1
37	E83524	Bushing	3
38	E88014	Bushing	1
39	E88007	Bushing	1
40	E83698	Tension Spring	1
41	E83491	Spring	2
42	E81953	Spring, Brush Lock	2
43	E81656	Retaining Ring - Internal	3
44	E83700	Shaft Key	1
46	E81657	Bearing	5
47	E83833	Hex Bolt M8x25 Zinc	6
48	E83801	Hex Bolt M8x35 Zinc	1
49	E83830	Hex Bolt M8x40 Zinc	3
50	E87285	Hex Bolt M8x50 Zinc	1
51	E88017	Screw, Pan Hd Phil Self Tap M4.8x13 SS	6
52	E81709	Nyloc Hex Nut, M8 Zinc	12
53	E83381	Nyloc Hex Nut, M10 Zinc	1
54	E88015	Nyloc Hex Nut, M20x17 Zinc	2
55	E88010	Hex Nut, M5	6
56	E82774	Flat Washer M6x12x1.6 SS	5
57	E81874	Flat Washer M8x17x1.6 Zinc	12
58	E20126	Cupped Spring Washer M8x18x1	2
59	E83404	Flat Washer M9x24x2.5 Zinc	3
60	E81918	Flat Washer M9x32x2.5 Zinc	1
61	E82773	Flat Washer M10x21x2 Zinc	1
62	E20253	Flat Washer M21x60x3 Nylon	2
63	E20350	Flat Hd Soc Machine Screw M8x50 Zinc	1
64	E81808	Poly Vee Belt	1
65	E20427	Plug	4

BRUSH DECK LIFT DIAGRAM

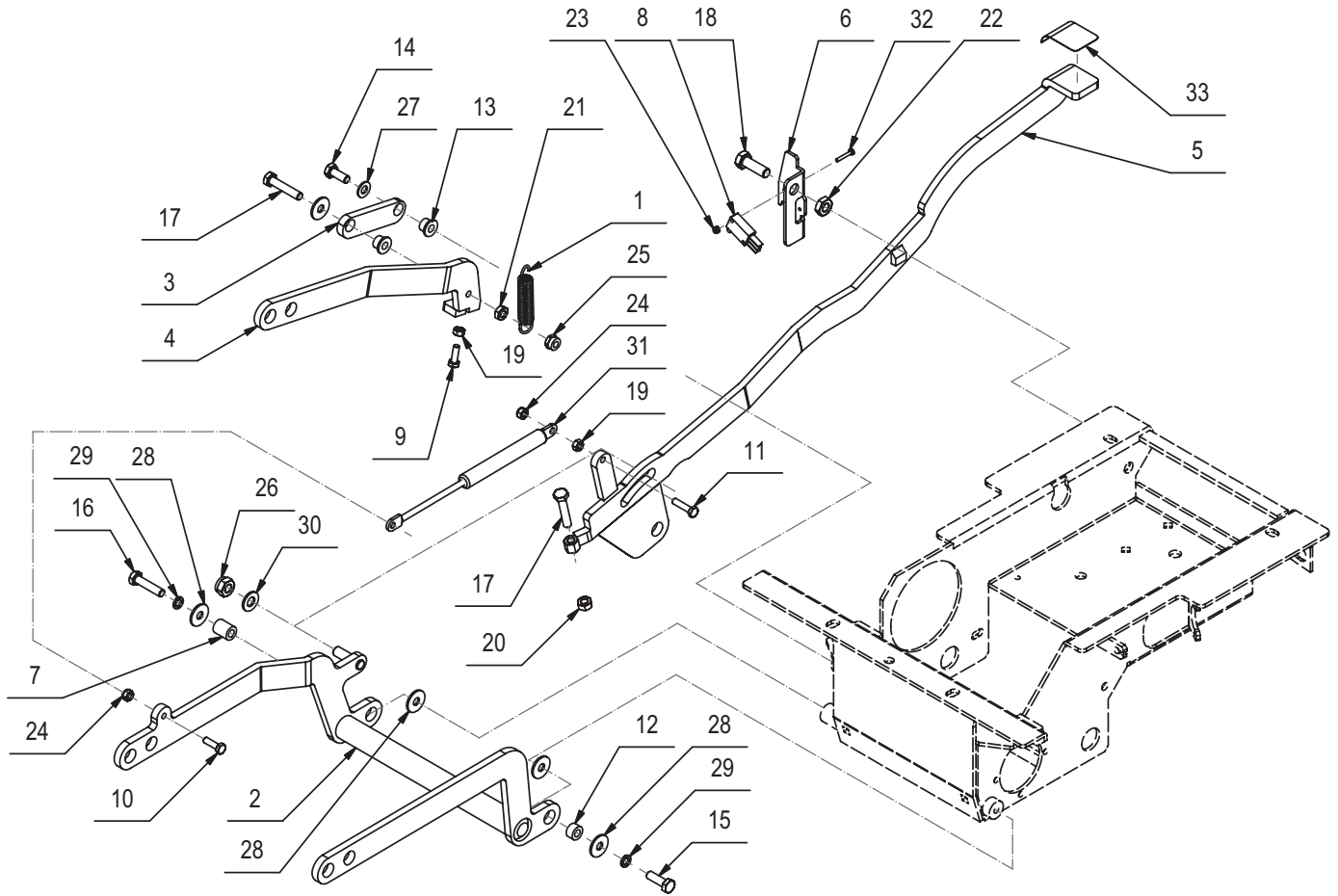

BRUSH DECK LIFT PARTS LISTING

Item#	Part #	Description	Qty.
1	E82689	Spring	1
2	E20219	Brush Deck Lift Arm Weldment	1
3	E20220	Brush Deck Lift Arm Linkage	1
4	E20062	Brush Deck Lift Idler Arm	1
5	E20282	Brush Deck Lift Foot Pedal	1
6	E20283	Foot Pedal Latch Plate	1
7	E20063	Bushing	1
8	E88279	Micro Switch Sealed	1
9	E20088	Hex Bolt M6x18 Zinc	1
10	E82772	Hex Bolt M6x20 Zinc	1
11	E20090	Hex Bolt M6x25 Zinc	1
12	E83932	Bushing	1
13	E82285	Bushing	2
14	E81917	Hex Bolt M8x20 Zinc	1
15	E83833	Hex Bolt M8x25 Zinc	1
16	E83801	Hex Bolt M8x35 Zinc	1
17	E83830	Hex Bolt M8x40 Zinc	2

Item#	Part #	Description	Qty.
18	E81017	Hex Bolt 10x30 Zinc	1
19	E83852	Hex Nut, M6x5	2
20	E83656	Hex Nut, M8x6.5 Zinc	1
21	E82808	Hex Jam Nut, M8X5 Zinc	1
22	E83875	Hex Jam Nut, M10X6 Zinc	1
23	E81673	Hex Nyloc Nut, M3 Zinc	2
24	E83550	NyLoc Hex Nut, M6 Zinc	2
25	E81709	Nyloc Hex Nut, M8 Zinc	1
26	E83381	Nyloc Hex Nut, M10 Zinc	1
27	E81874	Flat Washer M8x17x1.6 Zinc	1
28	E83404	Flat Washer M9x24x2.5 Zinc	5
29	E83704	Lock Washer M8x13x2.2 Zinc	2
30	E82773	Flat Washer M10x21x2 Zinc	1
31	E20130	Shock Absorber	1
32	E20533	Hex Bolt M3x20 SS	2
33	E20635	Abrasive Antislip Tape	1

SQUEEGEE DIAGRAM

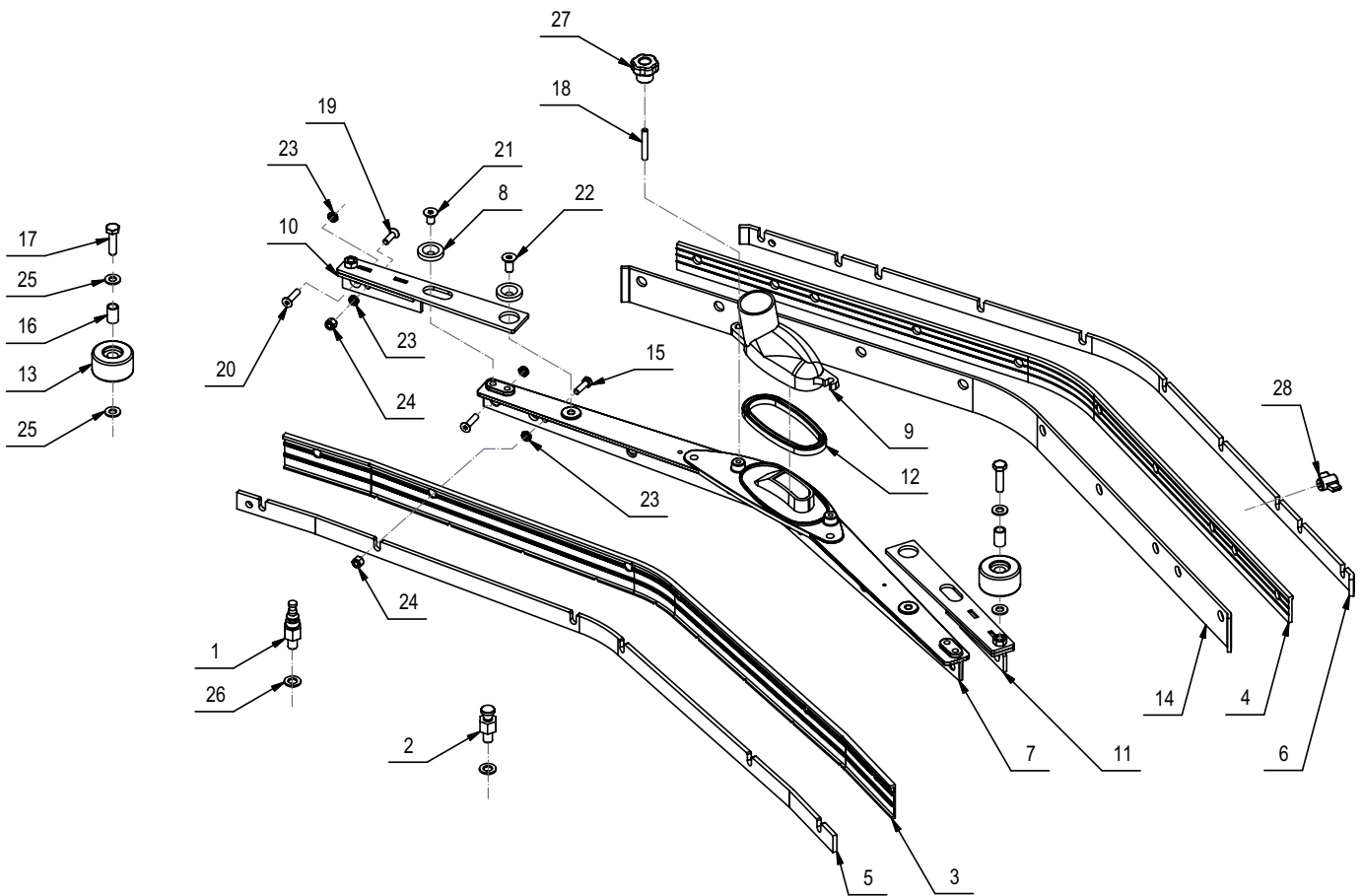

SQUEEGEE PARTS LISTING

Item#	Part #	Description	Qty.
1	E82275	Stud Bolt M10 Custom	1
2	E82280	Squeegee Pin	1
3	E81834	Squeegee Blade Front	1
4	E81835	Squeegee Support Blade Rear	1
5	E20617	Band Clamp	1
6	E20012	Band Clamp	1
7	E20573	Squeegee Shoe	1
8	E20498	Brass Washer - Custom	4
9	E82307	Squeegee Vacuum Adapter	1
10	E20572	Squeegee Shoe Extender	1
11	E20077	Squeegee Shoe Extender	1
12	E83971	Gasket	1
13	E82451	Wheel 45 OD x 25 W	2
14	E81833	Squeegee Blade Rear	1

Item#	Part #	Description	Qty.
15	E83914	Hex Bolt M6x20 SS	4
16	E82253	Bushing	2
17	E83802	Hex Bolt M8x30 Zinc	2
18	E82707	Set Screw Hex Soc Flat End M6x40 SS	2
19	E83831	Flat Hd Soc Machine Screw M6x20 SS	2
20	E81848	Flat Hd Soc Machine Screw M6x25 SS	10
21	E20345	Flat Hd Soc Machine Screw M8x14 Zinc	2
22	E20247	Flat Hd Soc Machine Screw M8x18 Zinc	2
23	E20114	Hex Jam Nut, M6X3 SS	16
24	E82775	Nyloc Hex Nut, M6 SS	6
25	E81874	Flat Washer M8x17x1.6 Zinc	4
26	E83948	Lock Washer M10x18x2.2 Zinc	2
27	E81435	Knob	2
28	E83591	Knob	10

SQUEEGEE YOKE DIAGRAM

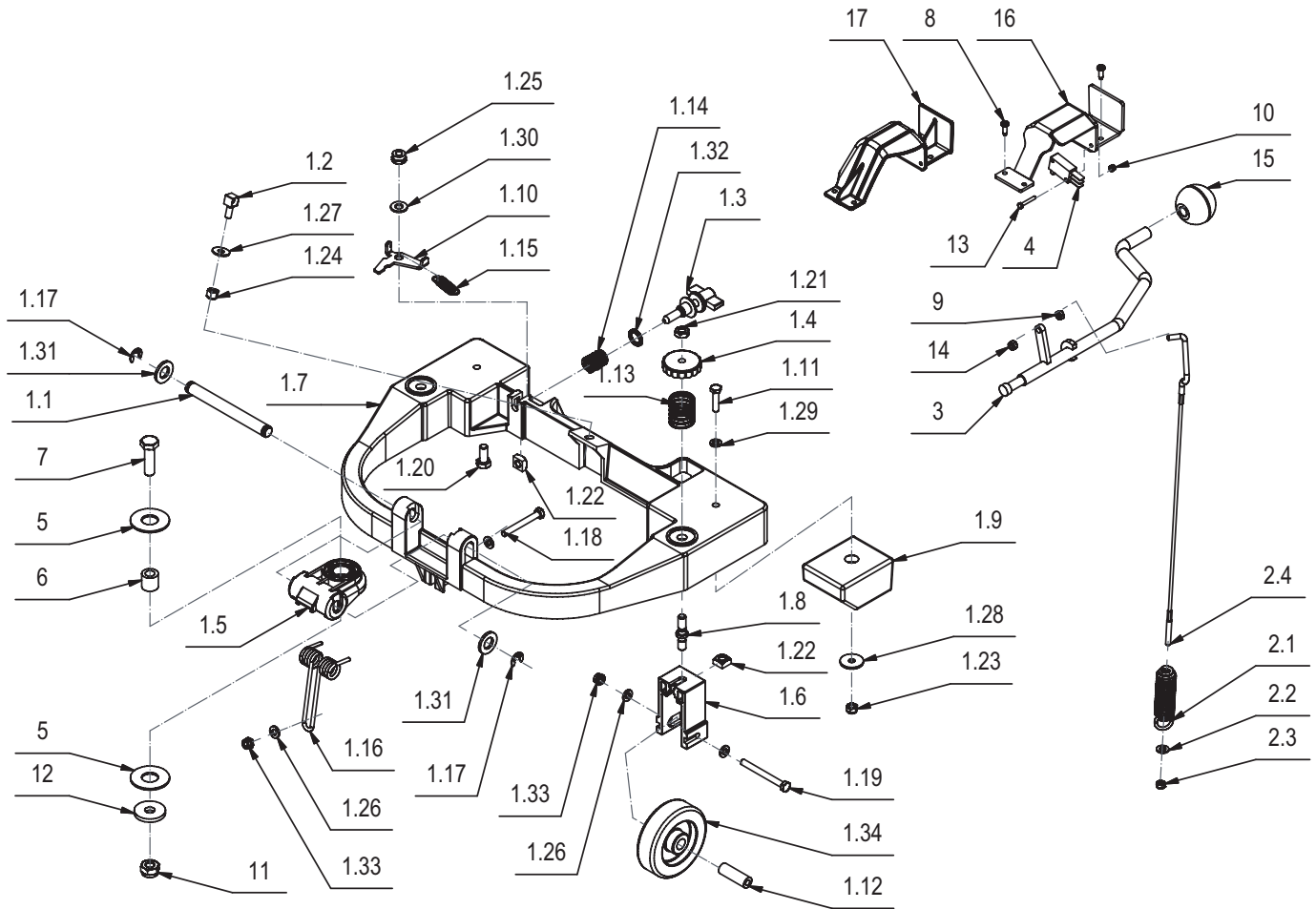

SQUEEGEE YOKE PARTS LISTING

Item#	Part #	Description	Qty.
1	E20623	Squeegee Yoke ASM	1
1.1	E20010	Pivot Pin	1
1.2	E82389	Eye Bolt	1
1.3	E82265	Adjuster, Squeegee	1
1.4	E83331	Knob	2
1.5	E85776	Pivot Connector	1
1.6	E20078	Squeegee Wheel Support	2
1.7	E81880	Squeegee Yoke	1
1.8	E20079	Threaded Adjuster Rod	2
1.9	E20080	Ballast	2
1.10	E86252	Latch, Squeegee Connector	1
1.11	E20090	Hex Bolt M6x25 Zinc	2
1.12	E82274	Bushing	2
1.13	E20091	Spring	2
1.14	E82703	Spring	1
1.15	E82453	Spring	1
1.16	E86158	Spring	1
1.17	E85498	E Style Circlip	2
1.18	E86159	Hex Bolt M6x50 Zinc	1
1.19	E83866	Hex Bolt M6x60 SS	2
1.20	E20098	Hex Bolt M8x18 Zinc	1
1.21	E83672	Hex Jam Nut, M8x5 SS	2
1.22	E83824	Square Nut, M8 SS	3
1.23	E83550	NyLoc Hex Nut, M6 Zinc	2
1.24	E82775	Nyloc Hex Nut, M6 SS	1
1.25	E81709	Nyloc Hex Nut, M8 Zinc	1
1.26	E82761	Flat Washer M6x12x1.6 Zinc	6
1.27	E82798	Flat Washer M6x18x1.5 Zinc	1

Item#	Part #	Description	Qty.
1.28	E83278	Flat Washer M6.5x24x2 Zinc	2
1.29	E82774	Flat Washer M6x12x1.6 SS	2
1.30	E20125	Flat Washer M8x17x1.6 SS	1
1.31	E85722	Flat Washer M13x24x2.5 Zinc	2
1.32	E81406	External Serrated Lock Washer M13x18 Zinc	1
1.33	E82314	Nyloc Hex Nut, M6 SS	3
1.34	E88280	Wheel 80 OD x 23 W	2
2	E88278	Squeegee Lift Rod ASM	1
2.1	E82279	Spring	1
2.2	E82761	Flat Washer M6x12x1.6 Zinc	1
2.3	E20382	Nyloc Hex Nut, M5x5 Zinc	1
2.4	E88250	Squeegee Lift Cable	1
3	E20313	Squeegee Lift Lever	1
4	E88279	Micro Switch Sealed	1
5	E20337	Flat Washer M17x40x2 Delrin	2
6	E20231	Bushing	1
7	E82455	Hex Bolt M10x35 Zinc	1
8	E83838	Screw 4.2 X 13	4
9	E82317	Hex Jam Nut, M5X3.5 Zinc	1
10	E81673	Hex Nyloc Nut, M3 Zinc	2
11	E83381	Nyloc Hex Nut, M10 Zinc	1
12	E20295	Flat Washer M10.5x32x4Zinc	1
13	E20533	Hex Bolt M3x20 SS	2
14	E20382	Nyloc Hex Nut, M5x5 Zinc	1
15	E20638	Knob	1
16	E20641	Bracket	1
17	E20641	Bracket	1

MAIN FRAME DIAGRAM

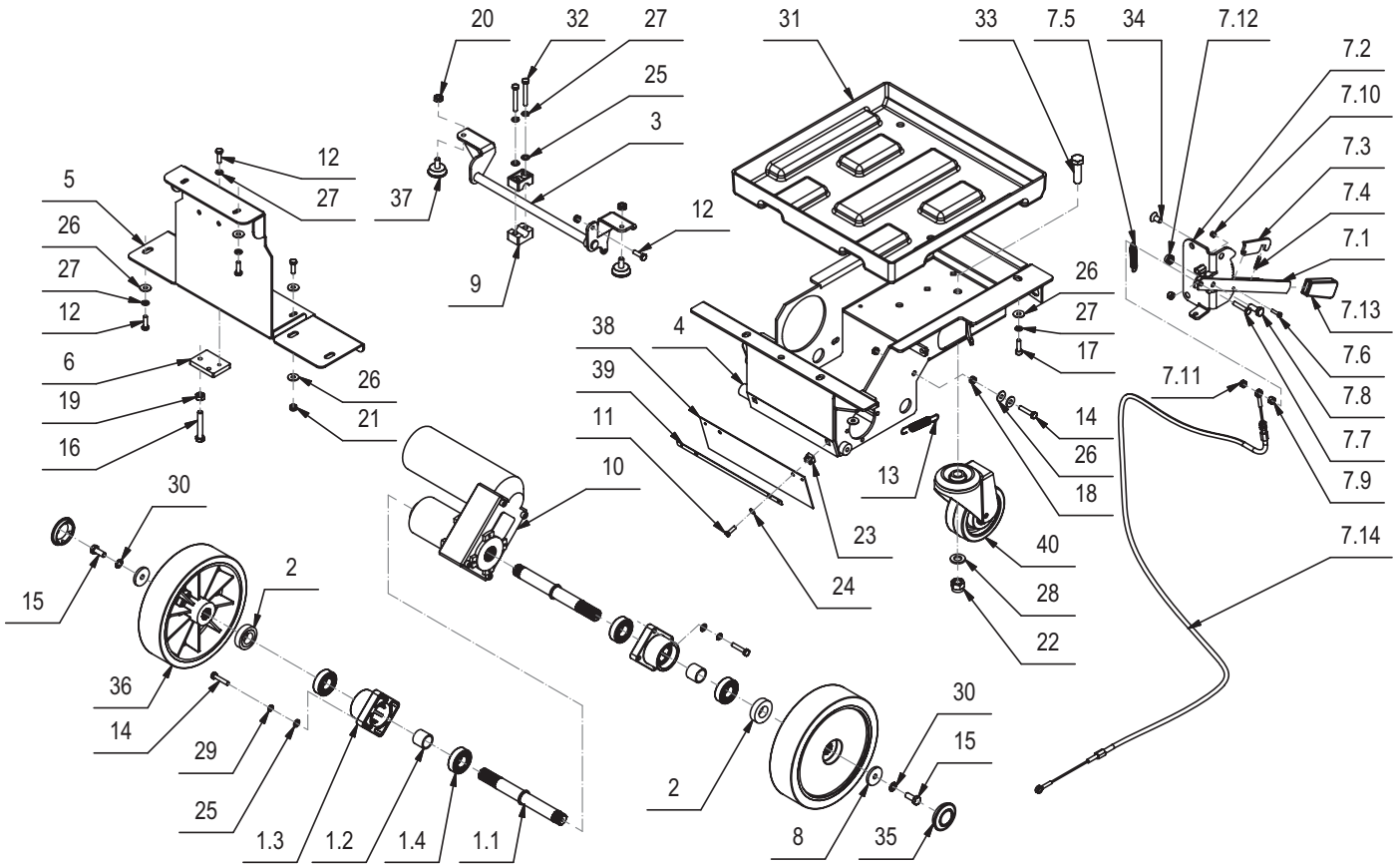

MAIN FRAME PARTS LISTING

Item#	Part #	Description	Qty.	Item#	Part #	Description	Qty.
1	E20003	Axle Shaft ASM	2	12	E82772	Hex Bolt M6x20 Zinc	7
1.1	E20478	Axle Shaft	1	13	E81056	Spring	1
1.2	E20482	Spacer	1	14	E83974	Hex Bolt M6x30 Zinc	9
1.3	E20081	Bearing Block	1	15	E81917	Hex Bolt M8x20 Zinc	2
1.4	E83923	Bearing	2	16	E87285	Hex Bolt M8x50 Zinc	1
2	E20013	Spacer	2	17	E20489	Soc Hd Cap Screw M6x20 Zinc	2
3	E20492	Brake Arm Weldment	1	18	E83852	Hex Nut, M6x5	2
4	E20407	Main Frame Weldment	1	19	E83656	Hex Nut, M8x6.5 Zinc	1
5	E20221	Frame Bracket	1	20	E82808	Hex Jam Nut, M8X5 Zinc	2
6	E20222	Plate	1	21	E83550	NyLoc Hex Nut, M6 Zinc	2
7	E20518	Brake Lever ASM	1	22	E20249	Nyloc Hex Nut, M12x15 Zinc	1
7.1	E20595	Brake Lever	1	23	E20250	Cage Nut M5	2
7.2	E20522	Brake Lever Bracket	1	24	E81618	Flat Washer M5x10x1 SS	2
7.3	E81928	Latch Lock	1	25	E82761	Flat Washer M6x12x1.6 Zinc	12
7.4	E82255	Spring	1	26	E82798	Flat Washer M6x18x1.5 Zinc	11
7.5	E83491	Spring	1	27	E82774	Flat Washer M6x12x1.6 SS	11
7.6	E20341	Hex Bolt M4x16 Zinc	1	28	E85722	Flat Washer M13x24x2.5 Zinc	1
7.7	E83974	Hex Bolt M6x30 Zinc	1	29	E81438	External Serrated Lock Washer M6 Zinc	8
7.8	E81917	Hex Bolt M8x20 Zinc	1	30	E83868	External Serrated Lock Washer M8 Zinc	2
7.9	E20112	Hex Nut, M6x6 Zinc	2	31	E88002	Battery Tray	1
7.10	E83867	Nyloc Hex Nut, M4x6 Zinc	1	32	E20360	Hex Bolt M6x45 Zinc	4
7.11	E83550	NyLoc Hex Nut, M6 Zinc	1	33	E20379	Hex Bolt M12x40 Zinc	1
7.12	E81709	Nyloc Hex Nut, M8 Zinc	1	34	E20297	Flat Hd Soc Machine Screw M8x16 Zinc	2
7.13	E20423	Brake Handle Grip	1	35	E81971	Wheel Cap	2
7.14	E20537	Brake Cable	1	36	E88282	Wheel 200 OD x 50 W	2
8	E81915	Flat Washer M8.2x32x4 Zinc	2	37	E20175	Brake Pad M8x17	2
9	E82834	Pivot Block	4	38	E88283	Chassis Splash Guard	1
10	E86182	Drive Motor 24VDC 150W	1	39	E20176	Band Clamp	1
11	E20084	Hex Bolt M5x16 SS	2	40	E20177	Caster	1

TANK ASSEMBLY DIAGRAM

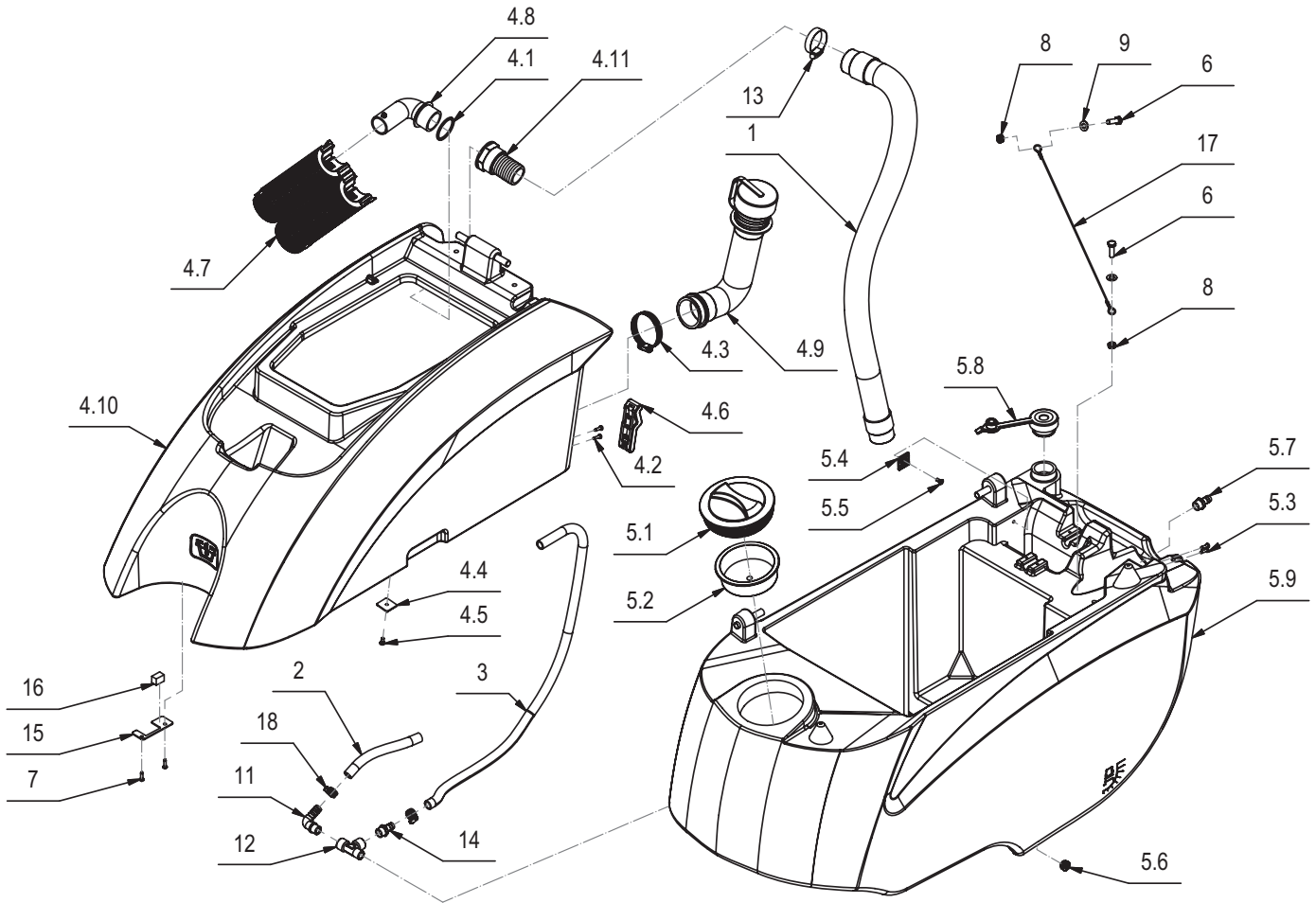

TANK ASSEMBLY PARTS LISTING

Item#	Part #	Description	Qty.
1	E12666	Squeegee Vacuum Hose	1
2	E88287	Hose, Glass Reinforced 17 OD x 12 ID x 200 L	1
3	E88288	Hose, Glass Reinforced 17 OD x 12 ID x 820 L	1
4	E20228	Recovery Tank ASM	1
4.1	E82341	Gasket	1
4.2	E20107	Screw, Pan Hd Phil Self Tap M4.2x16 SS	2
4.3	E20432	Hose Clamp	1
4.4	E81619	Support Bracket	1
4.5	E20468	Flat Hd Phil Machine Screw M5x12 Zinc	1
4.6	E20413	Latch	1
4.7	E88285	Filter, Cage	1
4.8	E20186	Elbow	1
4.9	E88286	Hose, Drain	1
4.10	E20202	Recovery Tank	1
4.11	E20189	Barbed Nipple	1
5	E20376	Solution Tank ASM	1
5.1	E82429	Cap	1
5.2	E82612	Filter	1
5.3	E20107	Screw, Pan Hd Phil Self Tap M4.2x16 SS	2

Item#	Part #	Description	Qty.
5.4	E81619	Support Bracket	1
5.5	E20468	Flat Hd Phil Machine Screw M5x12 Zinc	1
5.6	E20627	Cap	1
5.7	E82269	Barbed Fitting, 3/8 in.	1
5.8	E20185	Cap	1
5.9	E20201	Solution Tank	1
6	E83833	Hex Bolt M8x25 Zinc	2
7	E20107	Screw, Pan Hd Phil Self Tap M4.2x16 SS	4
8	E82808	Hex Jam Nut, M8X5 Zinc	2
9	E20127	Flat Washer M9x18x1.5 Zinc	2
10	E83935	Hose Clamp	3
11	E86275	Barbed Elbow	1
12	E20651	Tee Fitting	1
13	E20325	Hose Clamp	1
14	E82269	Barbed Fitting, 3/8 in.	1
15	E20399	Pivot Plate	2
16	E20190	Spacer Block	2
17	E88260	Lanyard	1

VACUUM UNIT DIAGRAM

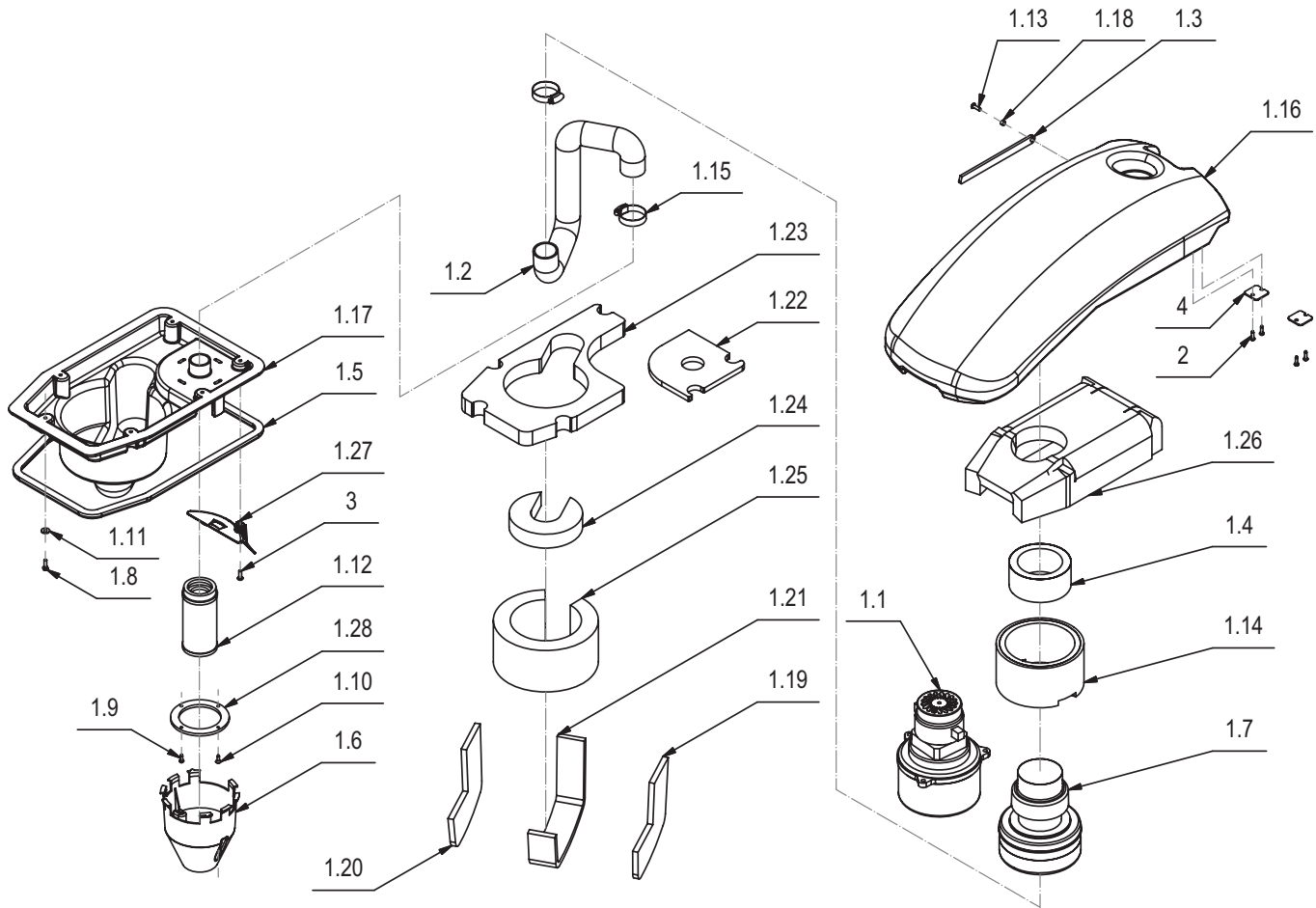

VACUUM UNIT PARTS LISTING

Item#	Part #	Description	Qty.
1	E20629	Recovery Tank Cover ASM	1
1.1	E20599	Vacuum Motor 24VDC 550W	1
1.2	E88290	Hose, Vacuum	1
1.3	E20064	Support Bracket	1
1.4	E20440	Sound Deadening Foam	1
1.5	E88289	Gasket	1
1.6	E81006	Vacuum Splash Guard	1
1.7	E88200	Vacuum Motor 36VDC 550W	1
1.8	E20084	Hex Bolt M5x16 SS	5
1.9	E20102	Screw, Pan Hd Phil Self Tap M4.2x13 SS	2
1.10	E83796	Screw, Pan Hd Phil Self Tap M4.2x16 Zinc	2
1.11	E20122	Flat Washer M5x15x1.5 SS	5
1.12	E88292	Filter, Cage	1
1.13	E20442	Button Hd Soc Machine Screw M5x16 Zinc	1
1.14	E20652	Sound Deadening Foam	1
1.15	E20325	Hose Clamp	2

Item#	Part #	Description	Qty.
1.16	E20199	Recovery Tank Cover	1
1.17	E20384	Vacuum Motor Cover	1
1.18	E20486	Bushing	1
1.19	E20266	Sound Deadening Foam	1
1.20	E20178	Sound Deadening Foam	1
1.21	E20179	Sound Deadening Foam	1
1.22	E20180	Sound Deadening Foam	1
1.23	E20181	Sound Deadening Foam	1
1.24	E20182	Sound Deadening Foam	1
1.25	E20183	Sound Deadening Foam	1
1.26	E20184	Sound Deadening Foam	1
1.27	E20191	Deflector	1
1.28	E20305	Mounting Ring	1
2	E20107	Screw, Pan Hd Phil Self Tap M4.2x16 SS	4
3	E20298	Soc Button Head Screw M5x16 SS	1
4	E20265	Plate	2

SOLUTION CONTROL DIAGRAM

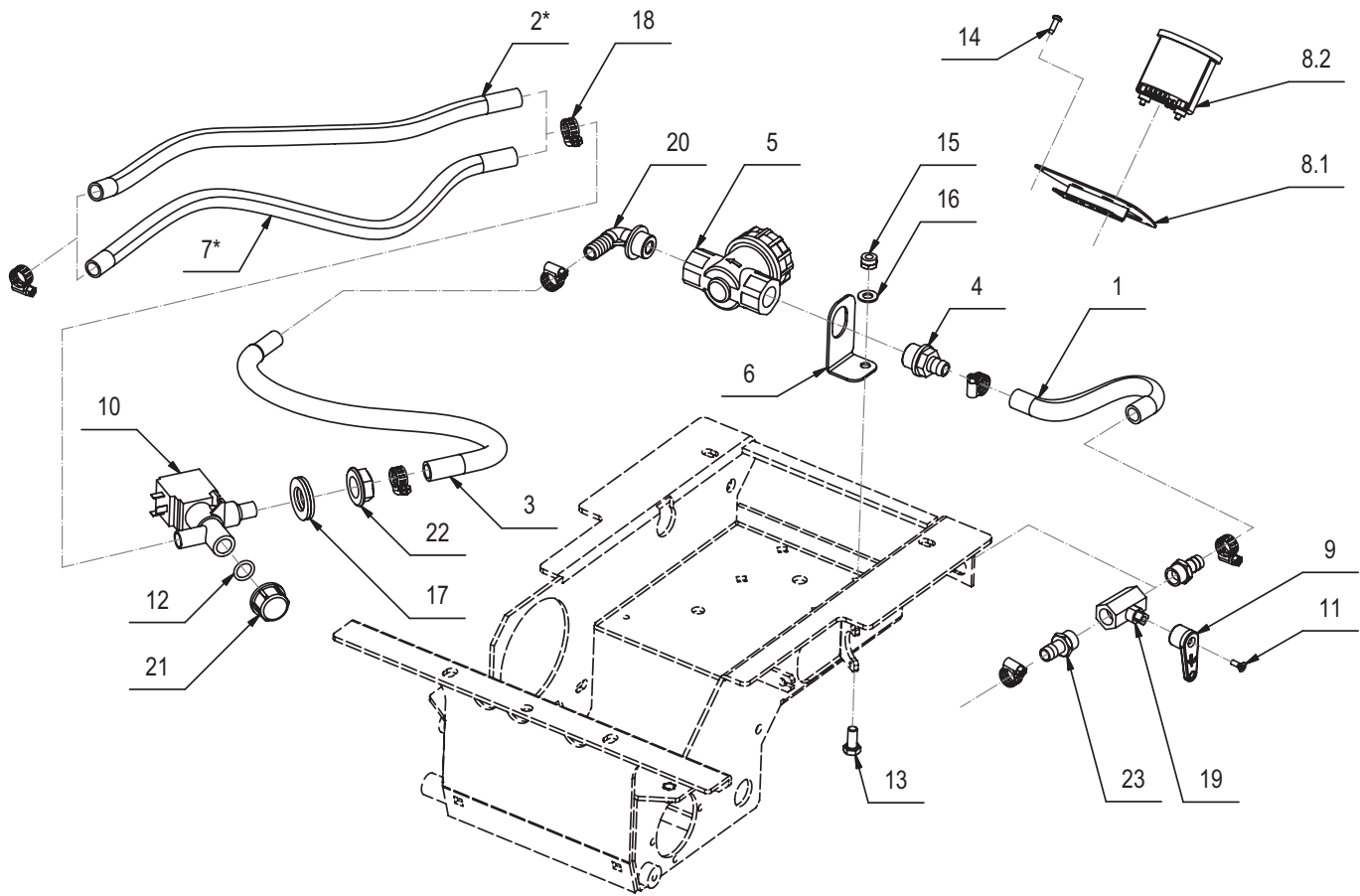

SOLUTION CONTROL PARTS LISTING

Item#	Part #	Description	Qty.
1	E20004	Tubing 12 ID x 200 L	1
2*	E20530	Tubing 12 ID x 460 L	1
3	E82693	Hose, 17 OD x 12 ID x L 420	1
4	E82447	Barbed Nipple	1
5	E88207	Filter	1
6	E20457	Bracket	1
7*	E20493	Tubing 12 ID x 560 L	1
8	E20463	Instrument Panel ASM	1
8.1	E20332	Panel	1
8.2	E88293	Hour Meter	1
9	E82705	Valve Lever	1
10	E82322	Solenoid Valve	1
11	E83858	Oval Hd SL Machine Screw M4x12 SS	1

Item#	Part #	Description	Qty.
12	E83617	O-Ring	1
13	E20098	Hex Bolt M8x18 Zinc	1
14	E83838	Screw 4.2 X 13	4
15	E81709	Nyloc Hex Nut, M8 Zinc	1
16	E81874	Flat Washer M8x17x1.6 Zinc	1
17	E20253	Flat Washer M21x60x3 Nylon	2
18	E85762	Hose Clamp	7
19	E83361	Ball Valve	1
20	E81446	Fitting	1
21	E83616	Cap	1
22	E20433	Ring Nut 1/2"	1
23	E82269	Barbed Fitting, 3/8 in.	2

HANDLEBAR DIAGRAM

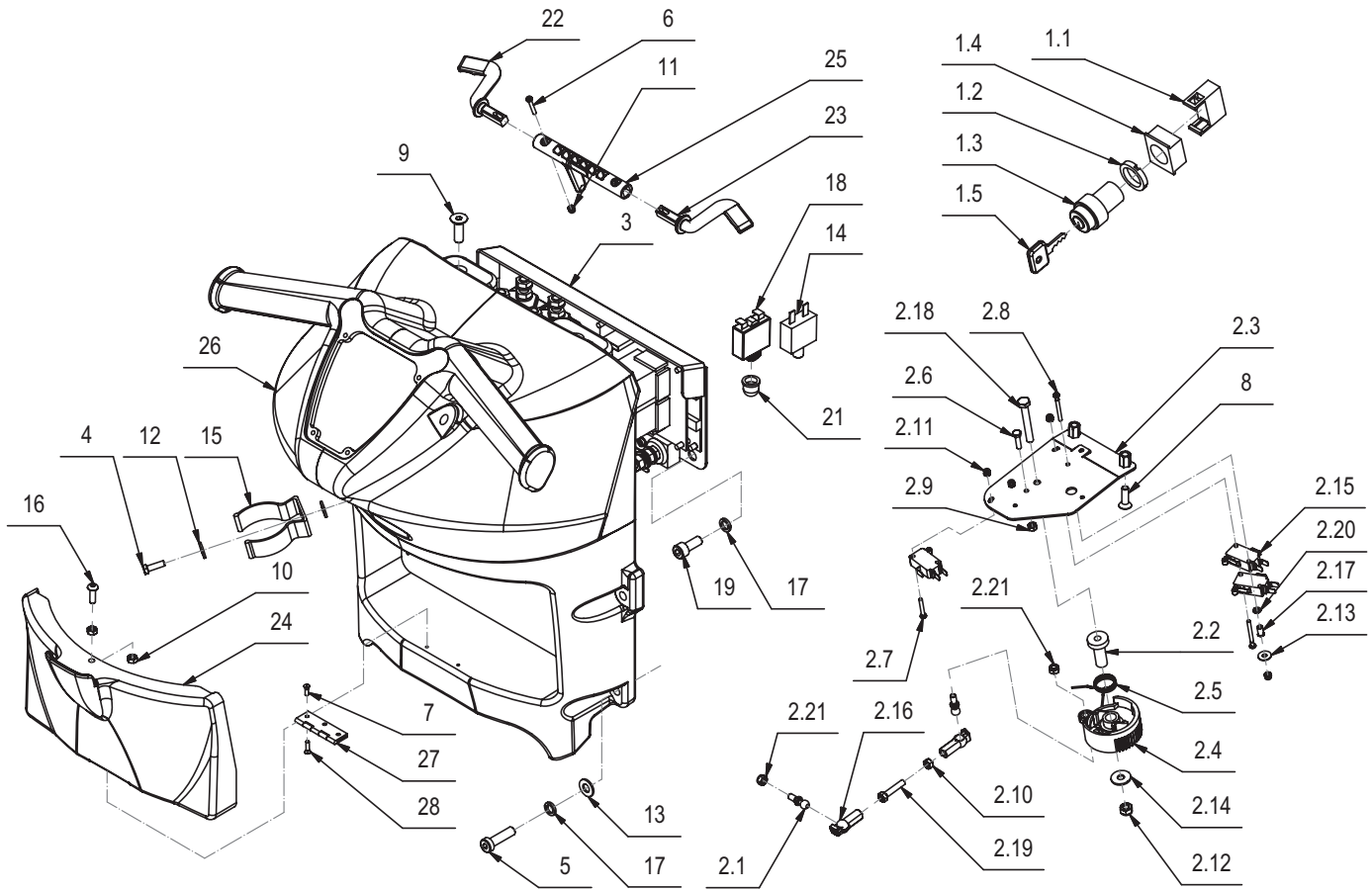

HANDLEBAR PARTS LISTING

Item#	Part #	Description	Qty.
1	E82351	Key Switch	1
1.1	E83173	Key Switch Contact	1
1.2	E83316	Key Switch	1
1.3	E83316	Key Switch	1
1.4	E81358	Switch Flange	1
1.5	E83315	Switch Key	1
2	E20223	Drive Control	1
2.1	E20330	Pin	2
2.2	E20574	Bushing	1
2.3	E20556	Plate	1
2.4	E81763	Cam	1
2.5	E82304	Spring	1
2.6	E20341	Hex Bolt M4x16 Zinc	1
2.7	E20242	Pan Hd Phil Machine Screw M3x20 Zinc	2
2.8	E20243	Pan Hd Phil Machine Screw M3x30 Zinc	2
2.9	E20248	Hex Nut, M4x4 Zinc	1
2.10	E82317	Hex Jam Nut, M5X3.5 Zinc	2
2.11	E81673	Hex Nyloc Nut, M3 Zinc	4
2.12	E83550	NyLoc Hex Nut, M6 Zinc	1
2.13	E83037	Flat Washer M4x12x1.6 Zinc	1
2.14	E82798	Flat Washer M6x18x1.5 Zinc	1
2.15	E82270	Micro Switch	3
2.16	E81625	Ball Stud Receiver	2
2.17	E20466	Insert	1
2.18	E20360	Hex Bolt M6x45 Zinc	1
2.19	E20362	Set Screw Hex Soc Dog Point M5x30 Zinc	1
2.20	E20469	Flat Washer M3 SS	2

Item#	Part #	Description	Qty.
2.21	E20382	Nyloc Hex Nut, M5x5 Zinc	2
3	E20625	Electrical Control Panel ASM	1
4	E83836	Hex Bolt M5x16 Zinc	1
5	E20288	Soc Hd Cap Screw M8x30 Zinc	4
6	E20242	Pan Hd Phil Machine Screw M3x20 Zinc	2
7	E81672	Flat Hd SL Machine Screw M3x10 SS	2
8	E20111	Flat Hd Soc Machine Screw M6x20 Zinc	2
9	E20346	Flat Hd Soc Machine Screw M8x25 SS	2
10	E82317	Hex Jam Nut, M5X3.5 Zinc	2
11	E81673	Hex Nyloc Nut, M3 Zinc	2
12	E20121	Flat Washer M5x15x1.5 Zinc	2
13	E81874	Flat Washer M8x17x1.6 Zinc	4
14	E83959	Circuit Breaker 20A	1
15	W87296	Drain Hose Clip	1
16	E20442	Button Hd Soc Machine Screw M5x16 Zinc	1
17	E81046	Lock Washer M8 Zinc	7
18	E83952	Circuit Breaker 30A	1
19	E20614	Soc Hd Cap Screw M8x20 Zinc	3
20	E88299	Cover, Thermal Switch	1
21	E20576	Cap	1
22	E88300	Lever, Left Switch	1
23	E88301	Lever, Right Switch	1
24	E20267	Door	1
25	E88267	Switch Cam	1
26	E20200	Handlebar Housing	1
27	E20400	Hinge	1
28	E20192	CHIPBOARD SCREW M3x12 Zinc	2

ELECTRICAL COMPONENTS DIAGRAM

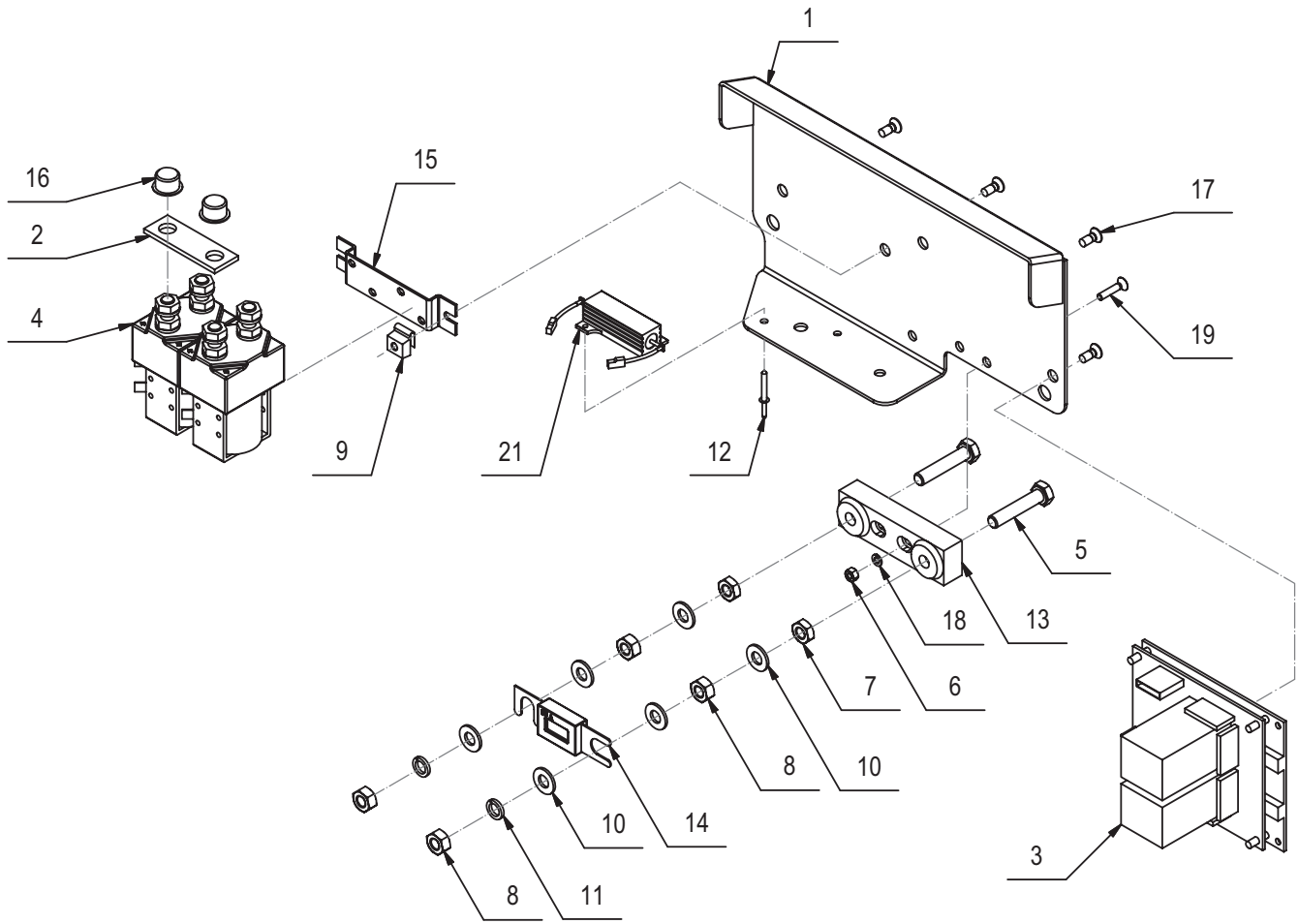

ELECTRICAL COMPONENTS PARTS LISTING

Item#	Part #	Description	Qty.
1	E20065	Bracket	1
2	E20536	Buss Bar	1
3	E20646	Variable Speed Controller	1
4	E83628	Contactora 24VDC	2
5	E20097	Hex Bolt M8x40 SS	2
6	E20248	Hex Nut, M4x4 Zinc	2
7	E83672	Hex Jam Nut, M8x5 SS	2
8	E20115	Hex Nut, M8x6.5 Brass	4
9	E20479	Spring Nut M5	2
10	E20124	Flat Washer M8x17x1.6 SS	6
11	E20252	Lock Washer M8x13x2.2 SS	2

Item#	Part #	Description	Qty.
12	E20377	Rivet, M2.4x8 AL	2
13	E20484	Fuse Block	1
14	E83170	Fuse, 80 Amp	1
15	E20448	Bracket	1
16	E20129	Cap	4
17	E20468	Flat Hd Phil Machine Screw M5x12 Zinc	5
18	E20475	Lock Washer M4 Zinc	2
19	E20301	Flat Hd Phil Machine Screw M4x20 Zinc	2
20	E20309	Cable Kit	1
21	E20368	Resistor	1

ELECTRICAL LISTING

Item#	Part #	Description
1	E82351	Key Switch
2	E88293	Hour Meter
3	E82511	Variable Speed Controller
4	E83628	Contactora 24VDC
5	E83628	Contactora 24VDC
6	E83170	Fuse, 80 Amp
7	E83952	Circuit Breaker 30A
8	E83959	Circuit Breaker 20A
9	E82322	Solenoid Valve
9A	E81035	Solenoid Valve
10	E20402	Electrical Connector 30A
11	E20402	Electrical Connector 30A
12	E20619	SB175 Red Electrical Connector

Item#	Part #	Description
13	E20619	SB175 Red Electrical Connector
F	E83972	Fuse 30A fasten
N	E83159	Relay 24VDC 20A
R	E20368	Resistor
MI 1	E82270	Micro Switch
MI 2	E82270	Micro Switch
MI 3	E82270	Micro Switch
MI 4	E88249	Micro Switch
MI 5	E88249	Micro Switch
M1A	E20543	Brush Motor 24VDC 560W
M2	E88291	Vacuum Motor 36VDC 550W
M3	E86182	Drive Motor 24VDC 150W

ELECTRICAL DIAGRAM

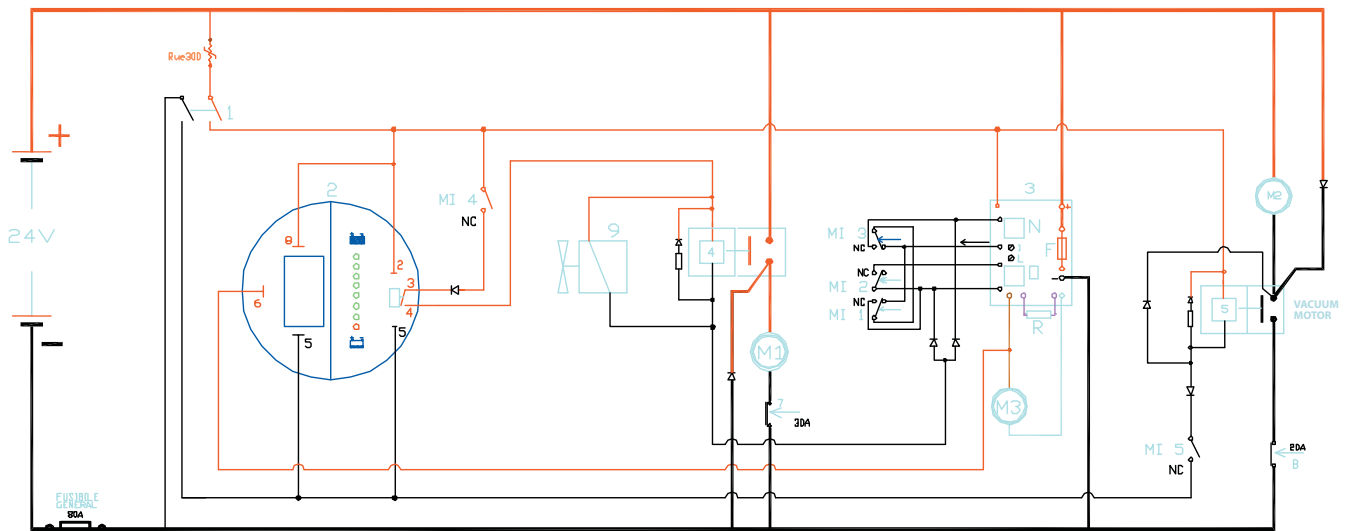

ELECTRIC HARNESS INSPECTION

1. Verify the functionality of the variable speed control card.
2. If necessary adjust the variable speed control card as follows:
 - Lift up at least one of the traction wheels.
 - Remove the handlebar to gain access to the electric controls.
 - Place voltage meter probes on the faston **M+** and **M-** of the variable speed control card.
 - Turn on the key master switch.
 - Pull the lever until you hear the forward first **micro switch click** (first speed).
 - The tester has to show a voltage between 14 and 15 V. If the reading is different adjust the **trimmer "MA Lenta"** (first speed).
 - Completely pull the switch lever until the second (maximum) speed **micro switch** is pressed. A voltage of 24 V (the same as the battery voltage) should be observed.
 - Acceleration adjustment: Adjust the **"ACC" trimmer** to let it be between 30° and 45° respect the central position rotating clockwise. Verify that with this adjustment the machine reaches maximum speed in 4 seconds.
 - Check the backwards direction.
 - Check the braking power of the traction motor. At maximum speed the machine should stop in about 3 feet.

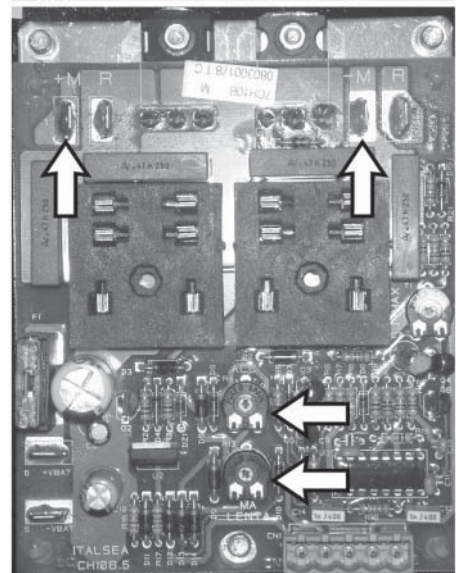
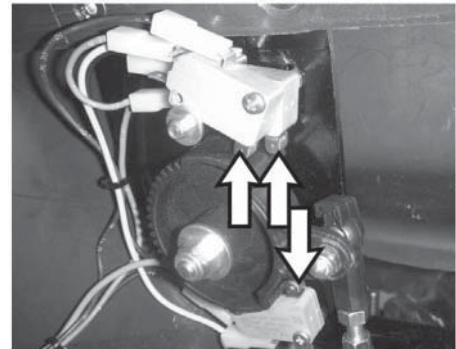

BATTERY CHECK CARD – HOUR METER

1. Verify that when turning on the machine the battery check card has the following starting sequence:
 - Turning on of the LED which correspond to the set-up (red LED = “0”).
 - Turning on of all the LEDs (check of the lamps)
 - Turning on of the LEDs depending on the charge of the battery
2. Verify the hour meter functionality
 - To verify which is the set-up you turn on the machine and check which is the first LED that turns on. Counting the LEDs since the left side any LED correspond to a position and the LED which turn on correspond to the current set-up.

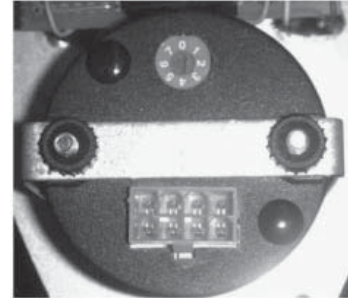
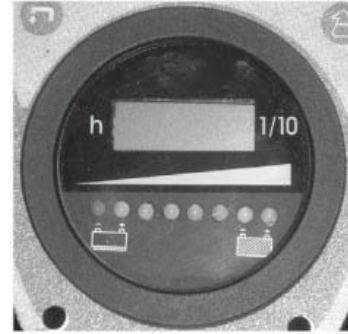

- Verify that if the machine uses wet cell batteries the adjustment is on position 1.



- Verify that if the machine uses GEL batteries the adjustment is on position 4.



WARNING: A wrong set-up of the battery control card can compromise the battery efficiency and damage then in irreversible way.

WATER PLANT INSPECTIONS

1. Verify the cleanness and functionality of the **solution filter** under the solution tank plug.

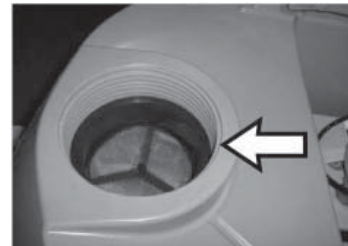

2. Check cleanness and sealing of the **solution filter**.

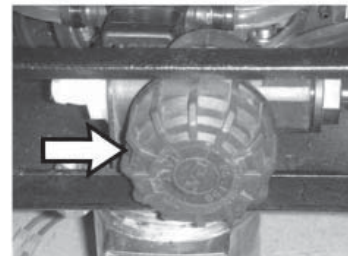

3. Confirm that solution tank is completely filled.
4. Verify the sealing of the hoses, **solenoid valve** and the **water valve**.
5. Verify that the solution, with valve completely open, falls continuously on the floor.

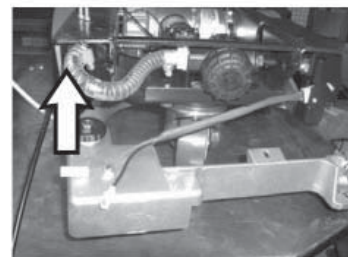

BRAKE ADJUSTMENT

1. Adjust the brake pads on the wheels to lock the wheels when the brake lever reaches the third ratchet notch.
2. To adjust the pads:
 - Unscrew the **M8 jam nut**.
 - Adjust the **pad**.
 - Tighten the **M8 jam nut**.

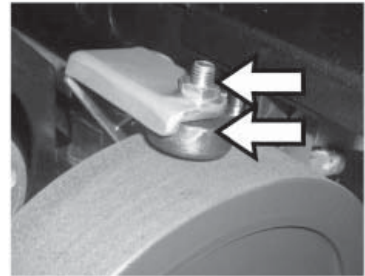
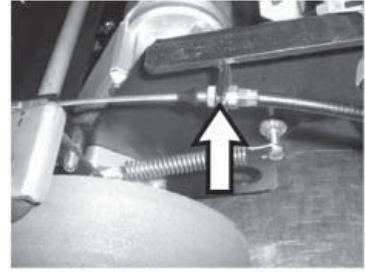

VACUUM SYSTEM INSPECTION

1. Confirm that the **float filter** is clean.
2. Check the air sealing of the **vacuum unit** on the recovery tank.
3. Verify the connections and the sealing of the vacuum hoses and the squeegee hoses.
4. Check the sealing of the **squeegee hose adapter**.
6. Vacuum micro switch adjustment:
7. Adjust the vacuum micro switch in a manner that when the cam on the squeegee lift lever **pushes on the micro switch** there is 0.5 mm of clearance between the micro switch roller and the cam.

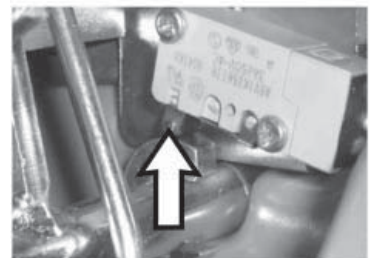
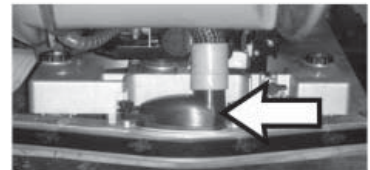
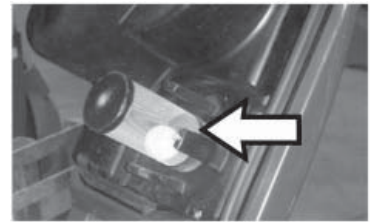

BRUSH ASSEMBLY ADJUSTMENT

1. Verify that when the foot lever is locked in the brush deck up position the **micro switch** is activated and the micro switch actuator has 0.5 mm of travel remaining.
2. If necessary adjust the micro switch as follows:
 - Unscrew the **nyloc M3 nut** and the **M3 screw**.
 - Adjust the micro switch.
 - Tighten the **nyloc nut** and the **M3 screw**.
 - When the adjustment is finished verify the proper functionality of the micro switch.
3. Adjust the **belt tensioner spring** to a length of **27 mm** in compression.

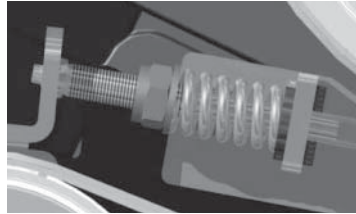

4. Adjust the transversal inclination of the brush deck:
 - Put the machine on a level floor.
 - Lower the brush base on the floor with brushes installed.
 - Loosen the **bolt and the nut M8** on the left brush deck lifting arm.
 - Lower the brush deck to allow the two brushes lay on the floor evenly.
 - Tighten the **M8 bolt**.
5. Verify that the shown bolt allows the brush deck to float evenly on the floor.
6. Verify that the brushes can be removed from the brush deck if necessary:
 - Lift up the brush deck.
 - Loosen the M6 jam nut.
 - Adjust the **M6 bolt** until the brushes have enough space to be removed from the brush deck.
 - Verify that with the brush base does not interfere with the solution tank.

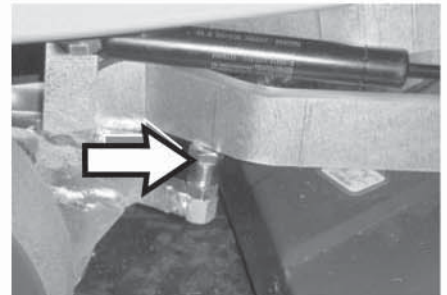
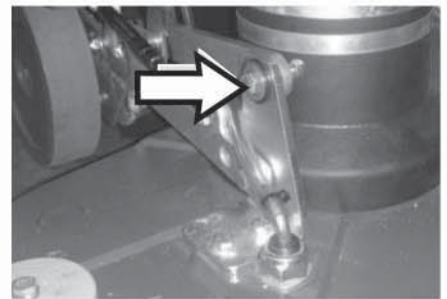
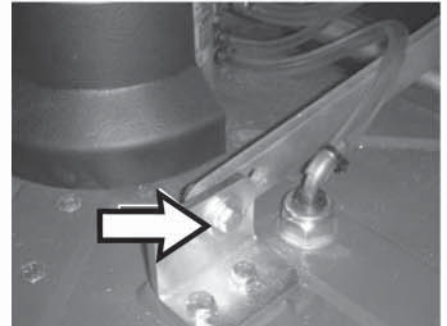
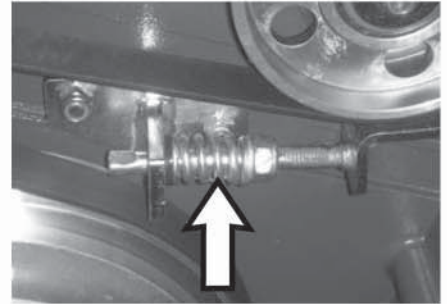
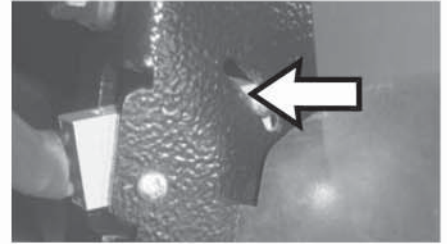
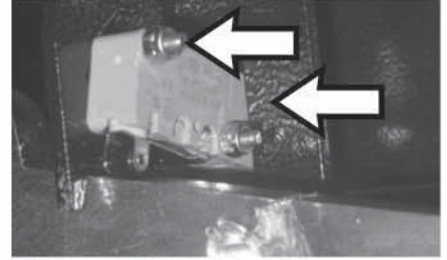

SQUEEGEE ADJUSTMENT

1. Adjust the **inclination adjuster** of the squeegee assembly until the squeegee blade has a uniform deflection along its entire length.
2. Adjust the height of the squeegee wheels using the **knob** such that the squeegee blade has an inclination between 30 and 45 degrees.

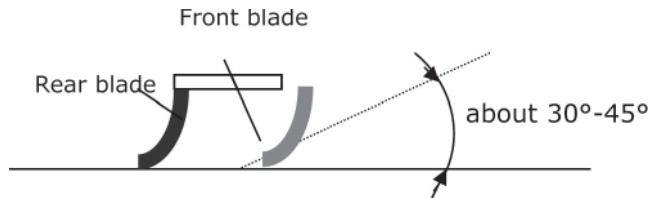

3. Verify that the squeegee assembly in up position does not interfere with the brush deck foot lever by adjusting the nyloc nut internal to the squeegee cable spring.

4. Adjust the spring tension so that the squeegee blades deflect when they contact the floor by tightening the nyloc nut.

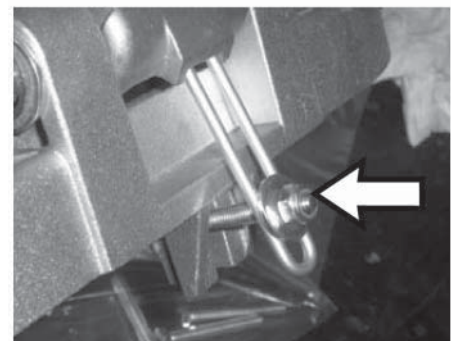
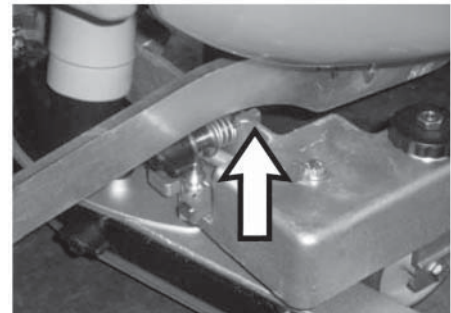
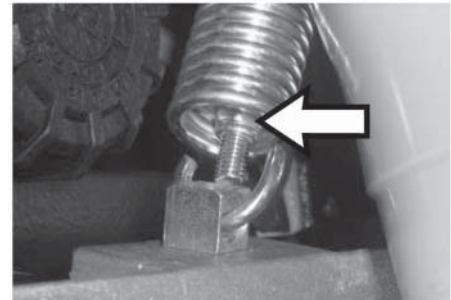
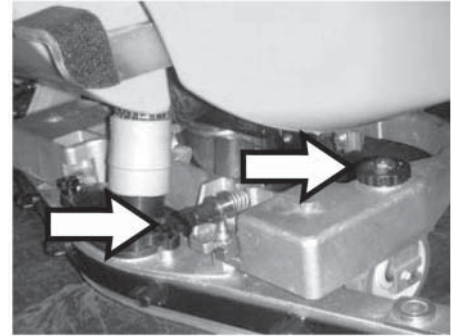

CHECK LIST

Functional check of the machine

- Check the functionality of switches and warning lamps.
- Check the functionality of the switch lever.
- Check the functionality of the brush deck.
- Check the functionality of the brush motor.
- Check the functionality of the solenoid valve.
- Check the functionality of the vacuum motor.
- Check the functionality of the brakes.
- Check the functionality of batteries and power cables.

Functional test of the machine

- Fill the tanks completely and verify that there are no leaks.
- Adjust the inclination and the height of the squeegee blades.
- Adjust the inclination of the brush deck.
- Check the function of the parking brake.
- Verify the forward and backward movement, acceleration and braking.

Final test

- Check all the functions: washing, drying and movement.

MAINTENANCE SCHEDULE

		Stealth ASD26BT	RECOMMENDED SERVICE INTERVALS (HOURS)					
			DAILY	50	100	250	400	750
Machine components	Suggested replacement							
BATTERIES	Check water level and add if necessary	DAILY						
	Check cables, connections and plugs		50					1,000
	Check cleanliness of machine battery tray				250			
ELECTRIC	Check state of power contactors and fuses			100				1,000
	Check state of electric cables crossing the machine					400		
SOLUTION TANK	Check cleanliness of solution filter	DAILY					750	
	Check solenoid valve, hoses and connections to the brush head			100		400		
	Check flow of water on the brushes				250			
RECOVERY TANK	Check the cleanliness of the tank	DAILY						
	Check filter and float system	DAILY						1,000
	Check vacuum and drain hoses	DAILY						1,000
	Check vacuum gasket and drain hoses plugs		50					1,000
BRUSH DECK	Check tension and wear of belt and state of the bearings				250			1,000
	Check the right brush inclination			100				
	Check brush attachments (rust, ruined parts, cracks)				250			
	Check wear of spraying guard		50			400		
	Check wear of brushes		50	100				
	Check function of the lifting/lowering element				250			
BRUSH MOTOR	Check cleanliness of air cooling inlet			100				
	Check wear of carbon brushes				250	400		
	Check amps consumption and noise level						750	
VACUUM MOTOR	Check noise level and cleanliness of the inlet hose			100				
	Check wear of carbon brushes				250		750	
	Check the vacuum performance, replace if necessary							1,000
SQUEEGEE	Check cleanliness of the squeegee blades and the squeegee adjustment	DAILY						
	Check wear of central squeegee blades		50	100				
	Check wear of front squeegee		50		250			
	Check squeegee yoke					400		
TRACTION SYSTEM	Check wear of motor carbon brushes				250		750	
	Check cleanliness air cooling inlet			100				
	Check wear of wheels					400		
	Check state of bearings					400		
	Check the function of the parking braking				250			
	Check wear of brake pads					400		1,000

Suggested replacement

WEAR ITEMS

Stealth ASD26BT

PART NUMBER	DESCRIPTION
E81668	Pad Holder
E81681	General Purpose 13" Scrub Brush
E82850	Medium Duty 13" Brush, .6MM Tuft
E82851	Heavy Duty 13" Brush, .9MM Tuft
E82852	Tynex 13" Brush, 1.0MM Tuft
E86143	Splash Guard
E81926	Blade, Right
E81835	Blade, Squeegee Rear
E81834	Blade, Squeegee Front
E12686	Squeegee Blade, Centra Shore 33
E88276	Squeegee Blade - Central Shore 40 Poly
E20700	Battery 12V 155 AH Wet
E88030	Battery 12V 110AH AGM
E88035	Charger 24VDC 12AMP 120VAC EXT AGM WET RSB50

BETCO US WARRANTY POLICY

10 year coverage

Subject to the conditions stated below, Betco warrants parts and labor on rotationally molded polyethylene tanks/ housings and injection molded vacuum head assemblies to be free from defects in materials and workmanship for a period of ten years to the original purchaser.

3 Year Coverage

Subject to the conditions stated below, Betco warrants parts and labor on all other Betco components to be free from defects in materials and workmanship for a period of three years to the original purchaser.

1 Year Coverage

Subject to the conditions stated below, Betco offers a limited warranty on parts and labor on the following equipment: parts and accessories to be free from defects in materials and workmanship for a period of one year to the original purchaser.

- DM Series Vacuums: #85506-00, #85507-00
- Bac Pac Lite Vacuum: #85903-00
- FiberPRO® Floor Dryer: #85507-00
- WORKMAN™ Series Vacuums: #85024-00, #85025-00, #85026-00, #85027-00
- CV100T Vacuum: #85023-00
- All Tools and Accessories
- All Battery Chargers
- All Batteries are pro-rated for 1 year

Allowable Travel Time Warranty Reimbursement:

Eligible equipment: All battery and propane powered equipment products. Warranty period: 90 days from date of sale to the original purchaser. A maximum 60 mile round trip at 44 cents per mile will be allowed for warranty consideration.

Propane Machine Warranty:

Honda engines are warranted by Honda for a period of 2 years against manufacturer defects. Kawasaki engines are warranted by Kawasaki for a period of 2 years against manufacturer defects. All other components (except wear items)* are warranted by Betco for a period of 3 years.

***Wear Items exempt from Warranty consideration include but may not be limited to: power cords, transport wheels, vacuum bags, belts, squeegee blades, pad drivers, clutch plates, handle grips, filters, screens, throttle cables, brushes and carbon brushes.**

Subject to the conditions and exceptions stated in this warranty, Betco warrants the Betco products to be free from defects in material and workmanship, under normal use and service, for the periods listed under the warranty policy to the original purchaser. At any time during the warranty period, Betco will furnish replacement parts for the Betco parts to the original purchaser. Such parts will be furnished and charged including transportation costs, to the original owner through any Betco authorized Service Distributor. If the original part is returned within the warranty policy period from date of delivery for inspection by Betco and is found to be defective the owner will be credited for the cost of replacement parts plus shipping and handling. Replacement parts that have become defective through wear or abuse are not included in this warranty.

This warranty does not apply to damage or defect caused by accident, misuse, negligence, fire, or to any Betco product which has been serviced or repaired by other than an authorized Betco Service Distributor or Betco factory personnel. This warranty is void if products are used for any purpose other than that which was intended. There are no other warranties expressed or implied. In no event shall Betco be liable for incidental or consequential damages or any damage to person or property. (Please note some states do not allow the exclusion or limitations for incidental and consequential damages)

