



## **Electronic Service Manuals**

This electronic document is provided as a service to our customers. We do not create the contents of the information contained in this document. Should you have detailed questions pertaining to the information contained in this document, you may contact Michco, or the manufacturer which provided the original information in this electronic deliverable. Michco's only part in this electronic deliverable was the electronic assembly process. By providing this manual online we are not guaranteeing parts availability.

You may contact Michco through the following methods:

**Phone (517) 484-9312**

2011 N. High St. -- Lansing, Michigan -- 48906

Fax: (517) 484-9836

Email: [CustomerService@Michco.com](mailto:CustomerService@Michco.com)

Website: [www.Michco.Com](http://www.Michco.Com)

Order Parts online at:

**[www.Michco.Com](http://www.Michco.Com)**

Directly to Parts & Service:

By Email: **[CustomerService@Michco.com](mailto:CustomerService@Michco.com)**

By Fax: (517) 484-9836

By Voice: (517) 484-9312

**Serving the Cleaning Industry Since 1922**

Notice: All copyrighted material remains property of original owners, all trademarks are property of respective owners. Manuals are subject to Manufacturer's reproduction limitations. Originals or reproductions were provided by manufacturers through a request. We make no warranty as to the correctness of information provided in this document and you assume all risk. By placing these manuals on line we are not declaring our corporation to be an manufacturer authorized dealer or provider, please check our web site for authorized manufacturers we represent.



E29941-00 E29943-00  
E29942-00



# STEALTH™ ASC20BT

20" Cylindrical Scrubber  
with Traction Drive



**Operator and Parts  
Manual**

# TABLE OF CONTENTS

RECEIVING THE MACHINE.....	3
TECHNICAL SPECIFICATIONS.....	4
GENERAL SAFETY REGULATIONS.....	5
MACHINE PREPARATION.....	6 - 12
OPERATION .....	13 - 14
TURNING OFF THE MACHINE .....	15
DAILY MAINTENANCE.....	16 -17
WEEKLY MAINTENANCE.....	18
TROUBLESHOOTING .....	19
BRUSH AND SELECTION USE.....	19
PARTS DIAGRAMS AND LISTINGS.....	20 - 43
ELECTRICAL SYSTEM.....	44
BATTERY CHECK CARD – HOUR METER.....	45
WATER PLANT INSPECTIONS .....	45
BRAKE ADJUSTMENT.....	46
VACUUM SYSTEM INSPECTION .....	46
SQUEEGEE ADJUSTMENT .....	47
CHECK LIST .....	48
MAINTENANCE SCHEDULE.....	49
WEAR ITEMS .....	50
WARRANTY .....	52

# RECEIVING THE MACHINE

Immediately check, when receiving the machine, that all the materials indicated on delivery documents have been received and also that the machine has not been damaged in transit. If it has been damaged, this damage must be immediately reported to the shipper and also to our customer's service department. Only acting promptly in this manner will make it possible to receive missing material and to be compensated for damage.

## INTRODUCTION

This is an automatic scrubber which, via the mechanical action of the rotating brush and the chemical action of a water/detergent solution, can clean many types of hard flooring. As it advances, it also collects the dirt removed and the detergent solution not absorbed by the floor.

**The machine must be used only for this purpose.** Even the best machines will only work well if used correctly and kept in good working order. We therefore suggest you read this instruction booklet carefully and re-read it whenever difficulties arise while using the machine. Please contact our technical service department or your dealers if you have any questions about the machine.

## Serial # Plate

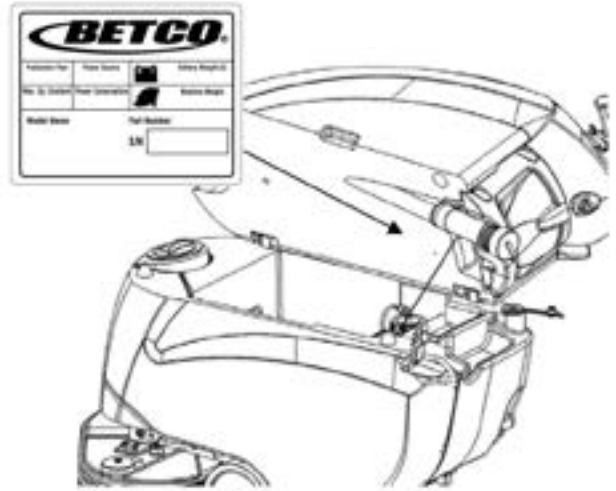

## SYMBOLS USED ON THE MACHINE



**Solution valve symbol**  
Used to indicate the water regulation switch



**Battery charge gauge**



**Battery symbol**



**Open book symbol**  
Used to tell the operator to read the manual before using the machine



**Maximum solution temperature gauge**  
Located near the solution tank inlet

<b>TECHNICAL DESCRIPTION</b>	<b>Measurement Unit</b>	<b>Stealth™ ASC20BT</b>
Working Width	Inches	20
Work Capacity	Sq. Ft. / Hr.	24,000
Brush Diameter	Inches	20
Brush RPM	RPM	800
Brush Pressure	Lbs. (Kg)	100 (45)
Brush Motor	V / HP / W	24 / 0.75 / 560
Drive Type		Automatic
Traction Motor	V / HP / W	24 / 0.20 / 150
Forward Speed	MPH (km/h)	1.9 (3)
Maximum Grade		10%
Vacuum Motor	V / HP / W	24 / 0.5 / 310
Vacuum Motor Suction	Millibar	188
Solution Tank Capacity	Gallons (L)	16 (60)
Recovery Tank Capacity	Gallons (L)	19 (72)
Weight of Machine (excluding batteries)	Lbs. (Kg)	253.5 (115)
Battery Charger	V / A	24 / 12
Machine Dimensions (Length/Width/Height)	in x in x in	54 x 42 x 22
Noise Level	dBA	58

# GENERAL SAFETY REGULATIONS

**The regulations below must be carefully followed in order to avoid harm to the operator and damage to the machine.**

- Read all labels on the machine carefully. Do not cover them for any reason and replace them immediately if they become damaged.
- The machine must be used exclusively by authorized and trained personnel.
- When operating the machine be careful of other people.
- The machine is not designed for cleaning carpets.
- The power cable outlet must be provided with a proper ground.
- Avoid damaging the power cable of the battery charger by crushing, bending, cutting or stressing it.
- Whenever the power cable of the battery charger is damaged, immediately contact a BETCO service center.
- Do not mix different types of detergent as this may produce harmful gases.
- Do not set containers on the machine.
- Machine storage temperature is between -10°F and 130°F, never store outside under humid conditions.
- Operating conditions: room temperature between 33°F and 100°F with relative humidity between 30% to 95%.
- Only use the machine in closed areas and do not expose it directly to rain.
- Never use the machine in an explosive environment.
- Do not use the machine as a means of transport.
- Never use acidic chemicals which could damage the machine.
- Avoid running the brushes with the machine stopped; this could damage the floor.
- Never vacuum up flammable liquids.
- Never use the machine to gather dangerous powders.
- Use a powder fire extinguisher in case of fire. Do not use water.
- Do not hit against shelving or scaffolding. The operator must always be equipped with the appropriate safety device (gloves, shoes, helmet, glasses, etc.)
- Do not use the machine on surfaces with an inclination greater than the one shown on the serial plate.
- The machine is designed to wash and dry floors simultaneously. Signal the presence of wet floors with suitable signs.
- If the machine does not work properly, perform routine maintenance. Otherwise, request the assistance of the BETCO technical service.
- When replacing parts ask for ORIGINAL spare parts from your Authorized BETCO Dealer and/or Retailer.
- Always turn off the machine and disconnect the battery connector whenever maintenance is performed.
- Never remove guards that require tools for removal.
- **Never wash the machine with direct or pressurized jets of water or with corrosive substances.**
- Have your BETCO service center check the machine once a year.
- To prevent the formation of scale in the solution tank filter, do not store the machine with detergent solution in the tanks.
- Before using the machine make sure that all doors and covers are positioned as shown in this operating and maintenance manual.
- When your BETCO machine is ready to be retired, the machine must be disposed of properly. It contains oils and electronic components. The machine was built using totally recyclable materials.
- Use only brushes furnished with the machine or those specified in the user's manual. Use of other brushes can compromise safety.
- When removing the battery, unplug the battery connection, unplug the charger and disconnect the battery terminals.
- Before recycling the machine, remove the battery.

# MACHINE PREPARATION

## 1. HANDLING THE PACKED MACHINE

The machine is contained in specific packaging.

It is not possible to place more than two packages on top of each other.

The total weight is 253.5 lbs. (115 kg).

The overall dimensions of the package are:

A : 49.6 in (1260 mm)

B : 28.4 in (720 mm)

C : 65.4 in (1660 mm)

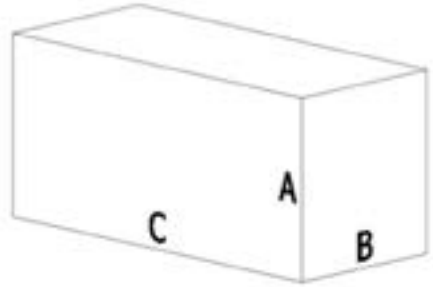

## 2. HOW TO UNPACK THE MACHINE

A. Remove the outer packaging.

B. The machine is attached to the pallet with wedges which block the wheels.

C. Remove these wedges.

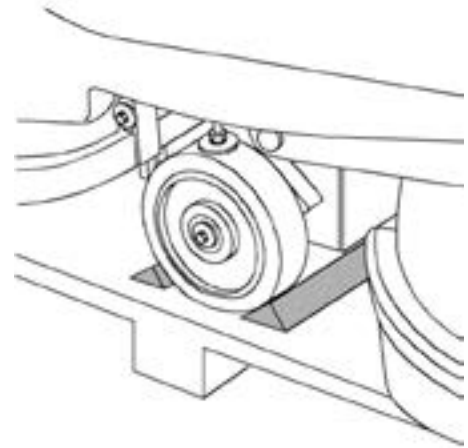

D. Use a ramp to get the machine down from the pallet, pulling it backwards.

E. Keep the pallet for any future transport needs.

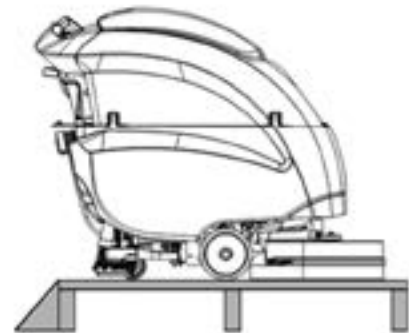

# MACHINE PREPARATION

## 3. BATTERY INSTALLATION

The machine will be supplied with a battery charger and either two 12 V Wet or AGM batteries. The batteries must be housed in the battery tray in the battery compartment beneath the recovery tank.

To insert the batteries you must:

- A. Lower the squeegee and base.
- B. Open the rear latch that secures the tank (2).
- C. Rotate the recovery tank as far as it will go, using the side handle (3).



**WARNING: To avoid acid spillage you can use sealed batteries.**

**WARNING: Perform one battery charging cycle before using the machine.**

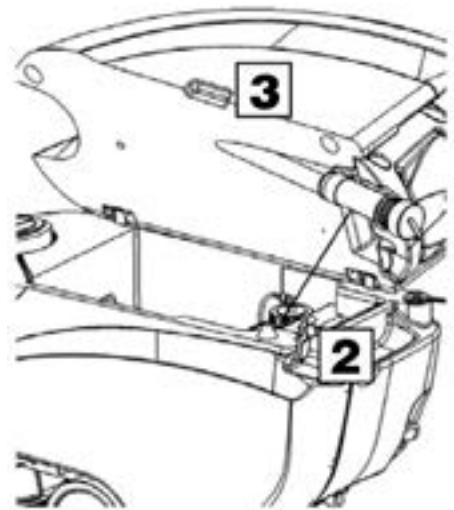

## 4. TYPE OF BATTERY

To power the machine you can use:

- Wet batteries
- AGM batteries
- Gel batteries

OTHER TYPES MUST NOT BE USED.

The maximum dimensions and weight are:

- Width 6.8 in. (172 mm)
- Length 14.2 in. (360 mm)
- Height 11.2 in. (285 mm)
- Weight 97 lb. (44 kg)



**WARNING: Your charger must be set according to the type of battery you install. Call BETCO customer service to ensure correct charger setting after replacement batteries are installed.**

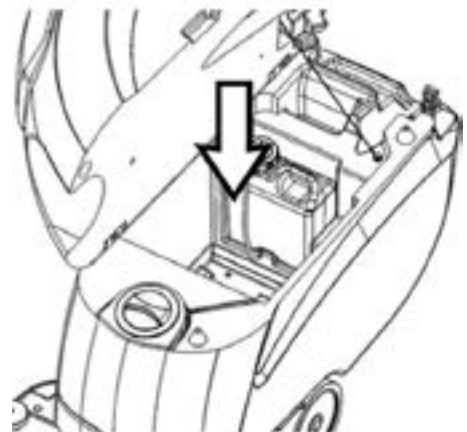

- The batteries must be handled using lifting and transportation means suitable for the weight and dimensions.
- They must be lifted by the handles on the upper part.
- They must be connected together in series, to obtain an overall voltage of 24 V on the lugs.
- The electrical connection operations must be carried out by certified trained personnel.

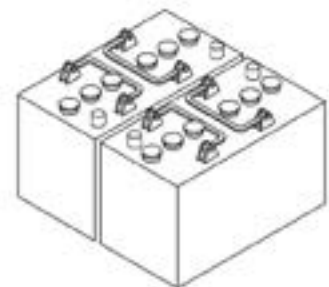

# MACHINE PREPARATION

## 5. BATTERY MAINTENANCE

For maintenance and recharging, follow the instructions provided by the battery manufacturer.

## 6. BATTERY DISPOSAL

When the battery reaches the end of its life, it must be disconnected by certified professional, then lifted (using the handles and suitable lifting device) to remove it from the battery compartment.

## 7. CONNECTING THE BATTERY CHARGER

Beneath the recovery tank there is the battery connector (7), the battery charger connector must be plugged into. Disconnect the battery plug and plug the charger into the machine plug.



**WARNING:** This process must be carried out by qualified personnel. The incorrect or imperfect connection of the cables to the connector can seriously harm people and damage objects.

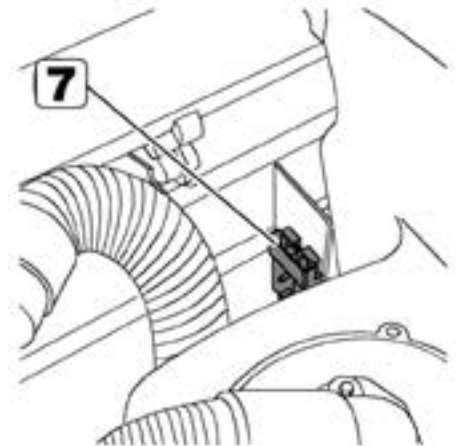

## 8. RECHARGING THE BATTERIES

Perform one complete battery charge cycle before using the machine. Avoid totally discharging the batteries! This can cause permanent damage. Recharge as soon as the battery discharged signal light starts to flash.



**WARNING:** Never leave the batteries completely discharged, not even if the machine is not being used. This can cause permanent damage to them. While recharging, keep the recovery tank raised.



**Danger of inhalation of gas and leakage of corrosive liquids.**



**Danger of fire.**

# MACHINE PREPARATION

## 9. CONNECTING THE BATTERY CONNECTOR

Connect the battery connector (2) to the machine connector (1)

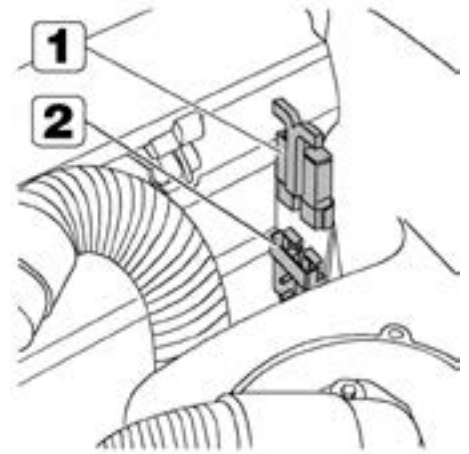

## 10. BATTERY INDICATOR

The battery indicator uses LEDs and has 8 positions (7 yellow - charged batteries, and 1 red - run down batteries).



***WARNING: A few seconds after the red indicator light comes on, the brush motor turns off automatically. The vacuum motor will remain in operation so that the remaining water can be removed from the floor.***



# MACHINE PREPARATION

## 11. INSTRUMENT PANEL COMPONENTS

The instrument panel components are identified as follows:

- A. Paddles to activate brushes / traction (located beneath the grip)
- B. ON/OFF key switch
- C. Battery level / hour meter

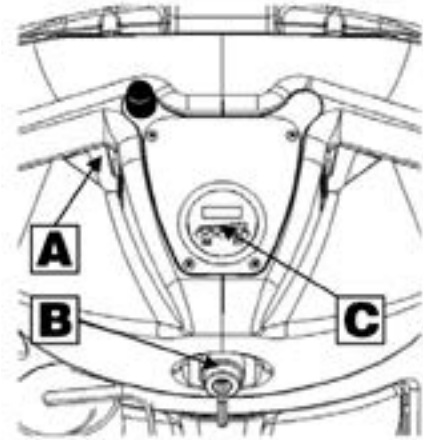

## 12. REAR COMPONENTS

The rear components are identified as follows:

- A. Pedal to raise the brushes
- B. Water level tube
- C. Solution tank water inlet cap
- D. Drain hose of recovery tank
- E. Latch to lock down the recovery tank
- F. Storage compartment
- H. Lever to raise the squeegee
- I. Brake lever
- J. Solution filter

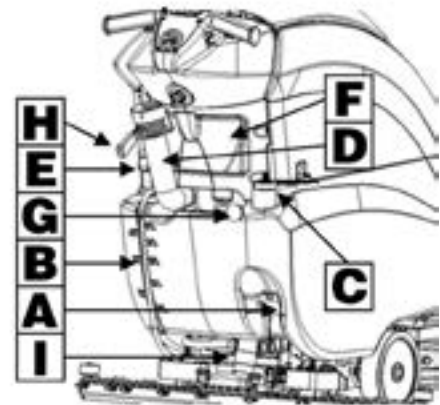

## 13. SIDE COMPONENTS

The side components are identified as follows:

- A. Solution flow control valve
- B. Handle to raise the recovery tank
- C. Handle to raise the vacuum unit
- D. Upper storage compartment

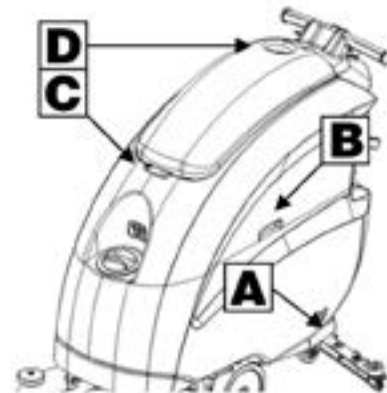

## 14. ASSEMBLING THE SQUEEGEE

For packaging reasons, the squeegee is supplied disassembled from the machine, and must be assembled as shown in the figure, inserting the small pin of the squeegee into the coupling mechanism until it locks into place.

Install the squeegee vacuum hose over the squeegee shoe adapter and be certain that the vacuum hose in to the right of the squeegee lift cable.

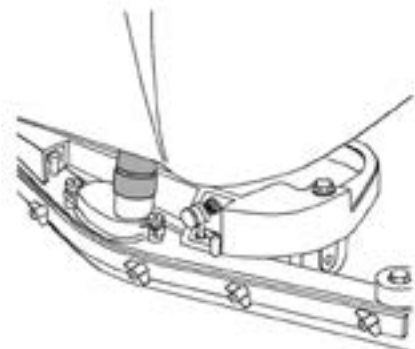

# MACHINE PREPARATION

## 15. ADJUSTING THE SQUEEGEE HEIGHT

The height of the squeegee must be adjusted based on wear of the squeegee. To do this, turn the knob (2) counter clockwise to raise the squeegee, and clockwise to lower it.

**Note:** the right and left wheels must be adjusted to the same level, so the squeegee works parallel to the floor.

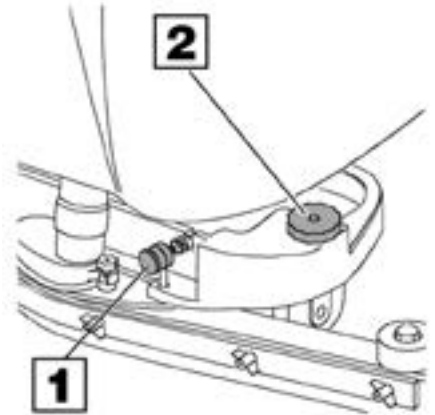

## 16. ADJUSTING THE SQUEEGEE INCLINATION

During working operation, the rear squeegee blade is slightly bent backwards (by about 0.2 in (5 mm)) uniformly over its entire length. If it's necessary to increase the bend of the squeegee blade in the center, you must tilt the squeegee backwards, rotating the adjuster (1) counter clockwise. To increase the bend of the squeegee at the outside edges of the squeegee, rotate the adjuster clockwise. After adjustment, tighten the jam nut.

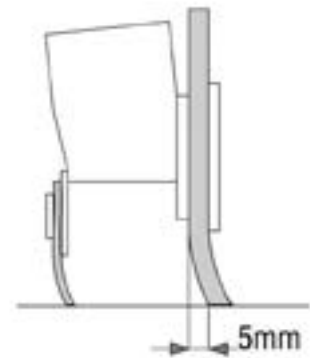

## 17. RECOVERY TANK

Check the drain hose cap (on the rear of the machine) to ensure it's closed.

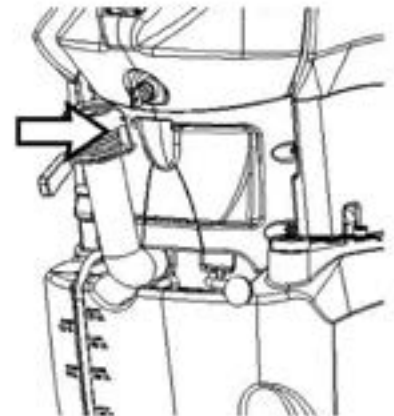

# MACHINE PREPARATION

## 18. SOLUTION TANK

Remove the front inlet cap and check the solution filter is correctly installed. Check the solution filter cover (beneath the tank) is correctly closed.

## 19. SOLUTION TANK

- Fill the tank with clean water in the front fill location (1) or at the rear fill location (2) at a temperature not exceeding 120°F (50°C).
- You can check the level of solution in the tank by means of the rear sight gauge (3).
- Add the liquid detergent into the tank, in the concentration and manner specified by the manufacturer. The formation of excess foam could damage the vacuum motor, so be sure to use only the correct amount of detergent.



**WARNING: Always use low-foam detergent. Introduce a small amount of defoaming liquid in the recovery tank before starting to work to prevent foam from being generated.**

**WARNING: Never use pure acids.**

## 20. ASSEMBLING THE BRUSHES

- A. Use the side parking brake lever to stop the machine.
- B. Make sure that the key switch is in the "0" position
- C. Raise the brush head by means of the appropriate pedal
- D. Loosen the wing nut (1)
- E. Rotate the side splash guard (2).
- F. Remove the splash guard (3)
- G. Remove the idle hubs
- H. Insert the brush (the side with 5 teeth) in the tunnel until it is coupled with the dragging device hub.
- I. Insert the idle hub of the mobile support in the brush (the side with 6 teeth).
- J. Repeat the operation for the second brush.
- K. Reassemble the side splash guard (3).
- L. Rotate the side splash guard (2).
- M. Fix the wing nut (1).

- Take care not to mix up the brushes, the blue brush should always be placed in the rear idle hub.
- Take care how the brushes are mounted, the assembly is correct if the direction of the bristles form an X looking from above.



**WARNING: you are advised to always wear protective gloves in order to avoid the risk of serious injury to your hands**

## 21. REGULATING THE SOLUTION

Regulate the quantity of water with the solution control valve (1).

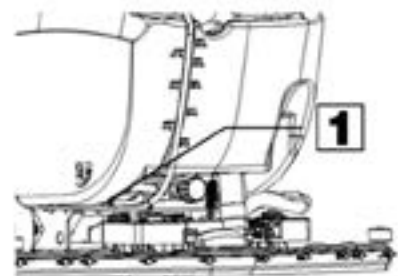
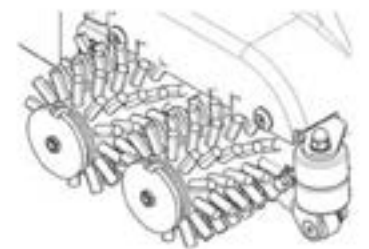
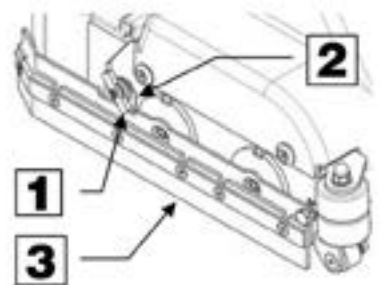
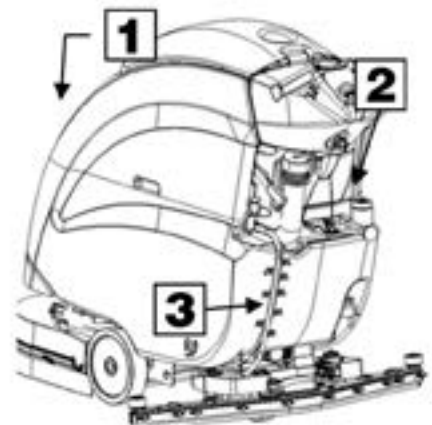
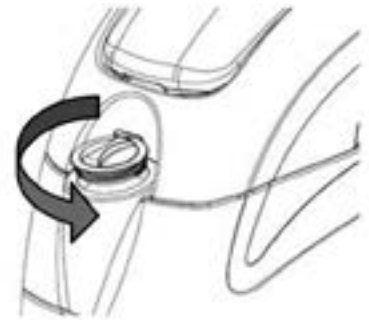

# OPERATION

## 1. PREPARING TO WORK

A. Connect the battery plug (1) to the machine plug

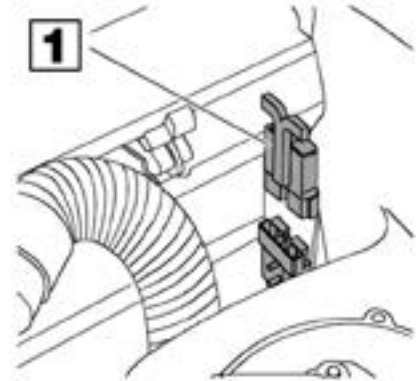

B. Turn the key (1) of the main switch to the "ON" position (clockwise). The battery charge level indicator lights will immediately come on.

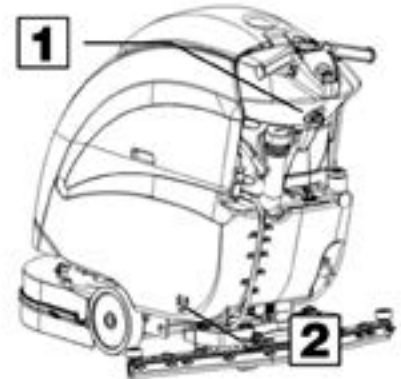

C. Turn on the solution control valve (2) (solution dispenses automatically while the brushes are turning).

D. Release the foot lever (3) and lower the brush deck. If the floor is particularly dirty, you can apply additional pressure to the brush deck by raising the foot lever (3) until the lock down is engaged.



E. Lower the squeegee, turning the lever (4) counter clockwise. The vacuum motor will switch on.

F. Check that the brake (5) is released.

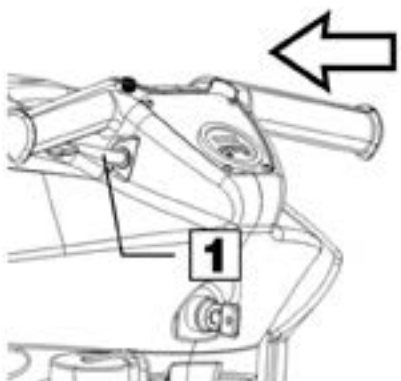

G. Pulling the switch levers (1), activates the brushes and the machine begins to move forward. During the first few feet, check that the amount of solution is correct, and that the squeegee dries the floor.

H. The machine will now start to scrub and dry until the solution tank is empty or recovery tank is full.

# OPERATION

## 2. REVERSE MOVEMENTS

To move in the reverse direction, push the switch levers (1) forward.



**WARNING:** When making reverse movements, raise the squeegee.

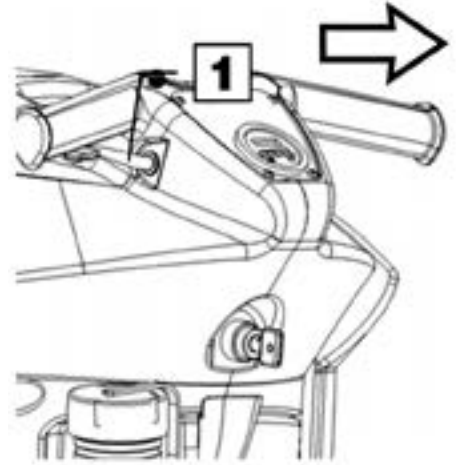

## 3. OVERFLOW DEVICE

The machine has a float in the filter basket that activates when the recovery tank is full and stops airflow into the vacuum.

You must empty the recovery tank by removing the cap of the rear drain hose.



**WARNING:** Always wear gloves when doing this operation to protect yourself from contact with hazardous chemicals.



# SHUTTING DOWN THE MACHINE

## 1. END OF WORK

When shutting down the machine and before you perform any type of maintenance:

- A. Turn off the solution control valve using the handle (1)
- B. Raise the brush deck using the foot lever (2)
- C. Raise the squeegee using the squeegee lift lever (3)
- D. Turn off the key switch (4)
- E. Move the machine where the tanks can be drained.

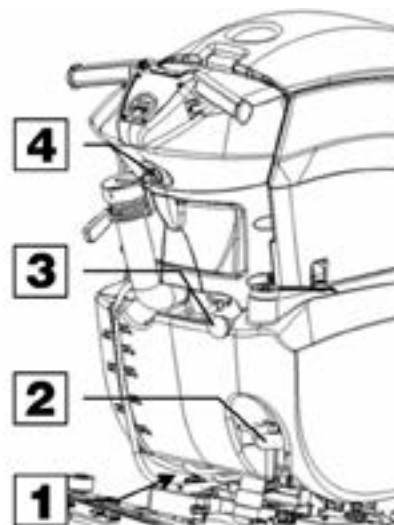

- F. Remove the drain hose from its holder, unscrew the drain cap and empty the recovery tank.
- G. The squeegee must be raised when the machine is not operating, to avoid deforming the squeegee blade blades.
- H. Remove the pads and clean them with water.



**WARNING: Always wear gloves when doing this operation to protect yourself from contact with hazardous chemicals.**

## 2. EMPTYING THE DUST HOPPER

Empty the hopper after work and before performing any type of maintenance, to do so proceed as follows:

- A. Push the knob (1) toward the rear of the machine and release the left side splash guard.
- B. Remove the hopper, empty and clean it thoroughly.
- C. Return the hopper.
- D. Reassemble the side splash guard.
- E. Raise the brush head at the end of work to avoid deforming the brushes.



**WARNING: Always wear gloves when doing this operation to protect yourself from contact with hazardous chemicals.**

# DAILY MAINTENANCE

## 1. CLEANING THE RECOVERY TANK

- Raise the vacuum unit (1).
- Remove the drain hose (2) and empty the tank.
- Rinse the inside of the tank with water.
- Close the vacuum unit on the machine and replace the drain hose cap and drain hose.



**WARNING:** Always wear gloves when doing this operation to protect yourself from contact with hazardous chemicals.

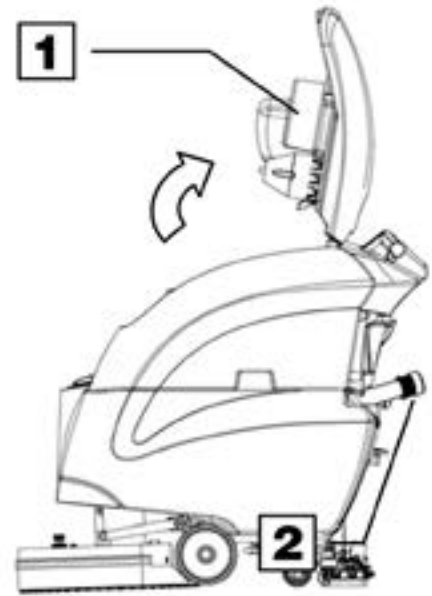

## 2. CLEANING THE VACUUM FILTER

- Raise the vacuum unit.
- Remove the vacuum filter cover by rotating it clockwise.
- Pull the filter straight down from the lid to remove it.
- Use water to clean the walls and base of the filter.
- Reassemble all the components.



**WARNING:** Always wear gloves when doing this operation to protect yourself from contact with hazardous chemicals.

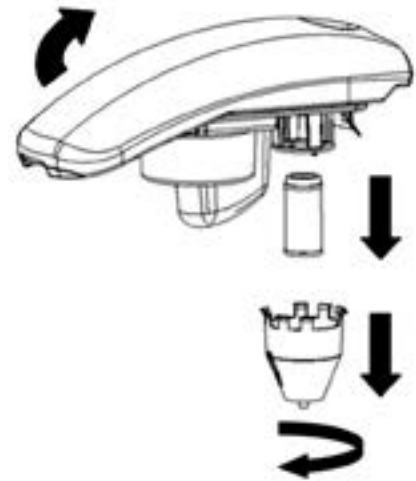

## 3. CLEANING THE VACUUM HOSE FILTER

- Raise the vacuum unit.
- Rotate the inner filter (1) and remove it.
- Use water to clean the walls and base of the filter.
- Reassemble all the components.



**WARNING:** Always wear gloves when doing this operation to protect yourself from contact with hazardous chemicals.

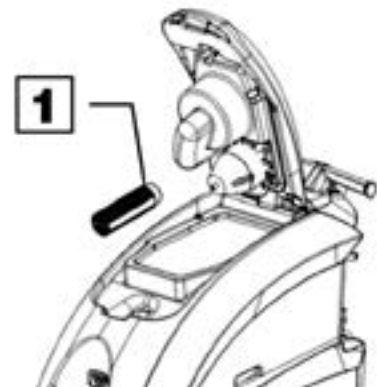

# DAILY MAINTENANCE

## 4. CLEANING THE SQUEEGEE

Ensure the squeegee is always clean, to improve drying results.

To clean:

- A. Remove the squeegee vacuum hose from the squeegee shoe adapter.
- B. Remove the cotter pins that attach the pins of the squeegee shoe.
- C. Disassemble the squeegee from its support.
- D. Loosen the wing nuts (1).
- E. Remove the squeegee band clamp and squeegee blade.
- F. Replace the squeegee blades.

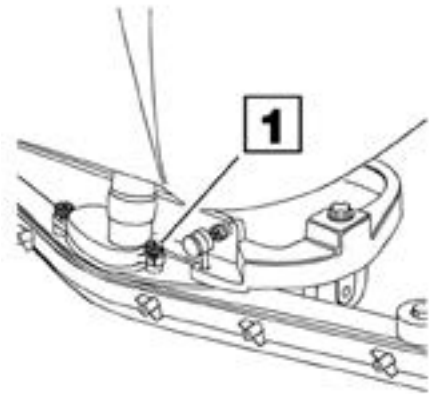

To reassemble the squeegee, repeat the operations in the reverse order.



**WARNING: Always wear gloves when doing this operation to protect yourself from contact with hazardous chemicals.**

## 5. DISASSEMBLING THE BRUSH

To remove the brushes:

- A. Turn the key to position "0".
- B. Apply the parking break using the side lever (1).



**ATTENTION: Before performing any maintenance, remove the keys from the panel and disconnect the batteries.**

- C. Loosen the wing nut (1).
- D. Rotate the side splash guard (2) and remove the side skirt (3).
- E. Remove the idle hubs.
- F. Remove the brushes and clean them.

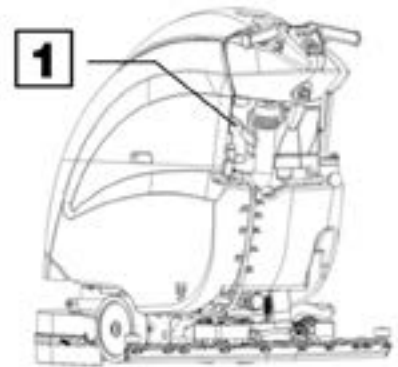

**WARNING: This operation must be carried out wearing protective gloves to protect against contact with dangerous solutions.**

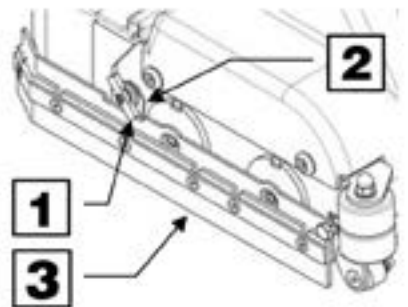

## 6. REPLACING THE SQUEEGEE BLADES

Check the state of wear of the squeegee blades and, if necessary, replace them.

To replace:

- A. Remove the squeegee hose from the squeegee shoe adapter.
- B. Push the release lever and release the right hand stud.
- C. Remove the squeegee vacuum from the squeegee yoke.
- D. Loosen the wing nuts.
- E. Remove the squeegee band clamp and squeegee blade.
- F. Replace the squeegee blades.



To reassemble the squeegee, repeat the operations in the reverse order.



**WARNING: Always wear gloves when doing this operation to protect yourself from contact with hazardous chemicals.**

# WEEKLY MAINTENANCE

## 1. CLEANING THE SQUEEGEE HOSE

Every week, or whenever vacuum seems to be unsatisfactory, check the squeegee hose for obstructions. To clean:

- A. Remove the hose from the squeegee shoe adapter on the squeegee shoe.
- B. Remove the other end from the recovery tank.
- C. Wash the inside of the hose with water from the end of the hose which is connected to the recovery tank.
- D. Reassemble the hose.



**WARNING:** Always wear gloves when doing this operation to protect yourself from contact with hazardous chemicals.

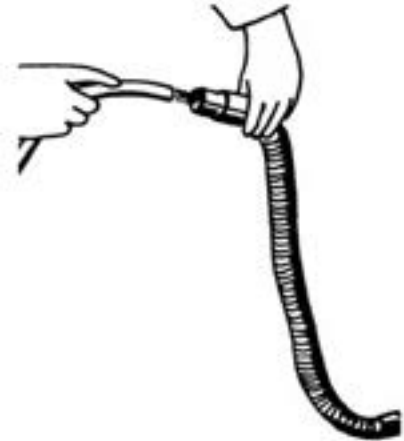

## 2. CHECKING THE BRAKE

Every week, check the distance between the brake pads and the wheels. If necessary, adjust them, so the pads are 0.12 inches away from the transport wheels at a distance of 0.12 in (3 mm) when released.

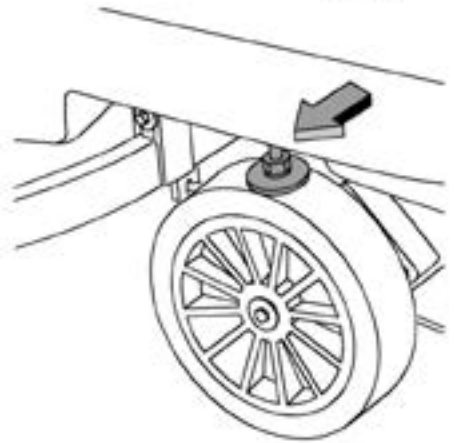

## 3. CLEANING THE SOLUTION TANK

- A. Loosen the solution tank cap.
- B. Rinse with water.
- C. Loosen the drain cap (1) located on the filter, and empty the tank.



**WARNING:** Always wear gloves when doing this operation to protect yourself from contact with hazardous chemicals.

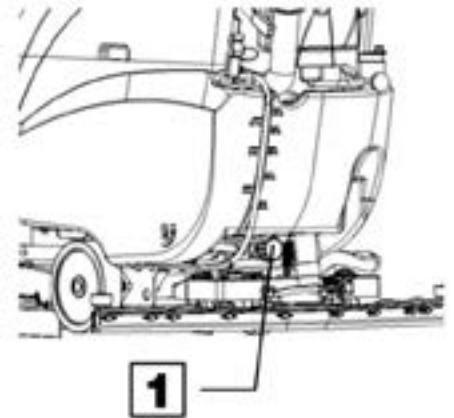

# TROUBLESHOOTING GUIDE

## INSUFFICIENT WATER ON THE PAD

1. Verify that the solution control valve – located beneath the symbol – (1) is turned on.
2. Verify that there is water in the solution tank.

## THE MACHINE DOES NOT CLEAN WELL

1. Check the state of wear of the scrubbing pad and, if necessary, replace it.
2. Use a different kind of scrubbing pad.

## THE SQUEEGEE DOES NOT DRY THE FLOOR

1. Ensure that the squeegee blades are clean.
2. Adjust the inclination of the squeegee.
3. Ensure the vacuum hose is correctly installed.
4. Check the inner filter of the recovery tank to ensure it is not dirty and, if necessary, clean it thoroughly.
5. Disassemble the entire vacuum unit and clean it.
6. Replace the squeegee blades, if worn.
7. Ensure the vacuum motor is turned on.
8. Check squeegee wheel adjustment.

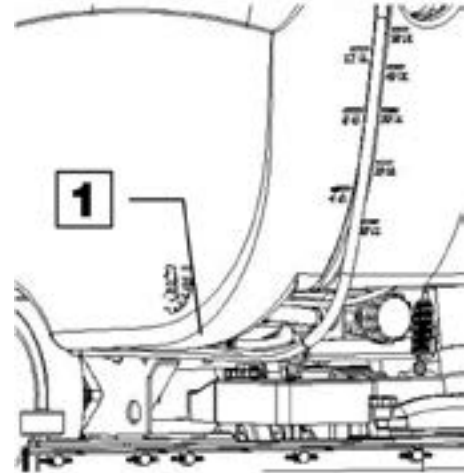

## TOO MUCH FOAM IS GENERATED

Check that low-foam detergent is being used. If necessary add a small amount of defoamer liquid to the recovery tank. Remember that more foam is generated when the floors are not very dirty. Dilute the detergent more when cleaning floors that are not very dirty.

---

## CHOOSING AND USING THE BRUSHES

### POLYPROPYLENE BRUSH (PPL)

Used on all types of floors. Good resistance to wear and tear, and hot water (no greater than 140°F (60°C)).

### NYLON BRUSH

Used on all types of floors. Excellent resistance to wear and tear and hot water (even over 140°F (60°C)).

### ABRASIVE BRUSH

The bristles of this type of brush are coated with highly aggressive abrasives. It is used to clean very dirty floors. To avoid floor damage work only with the brush pressure necessary.

### THICKNESS OF THE BRISTLES

Thicker bristles are more rigid and are therefore used on smooth floors or floors with small joints. On uneven floors or those with deep joints, it is advisable to use softer bristles which can enter the gaps easier. When the bristles are worn and too short, they will become rigid and are no longer able to penetrate and clean deep down and the brushes tends to jump.

### PAD DRIVER

Pad Holders and scrub pads are recommended for cleaning smooth surfaces. There are two types of pad holder:

1. The traditional pad holder has a series of anchor points that allow the abrasive floor pad to be held and dragged while working.
2. The CENTER LOCK type pad holder not only has anchor points, but also a snap-type central locking system made of plastic that allows the abrasive floor pad to be centered and held without any risk of it becoming detached. This type of pad driver is recommended above all for machines with more than one brush.

# BRUSH DECK DIAGRAM

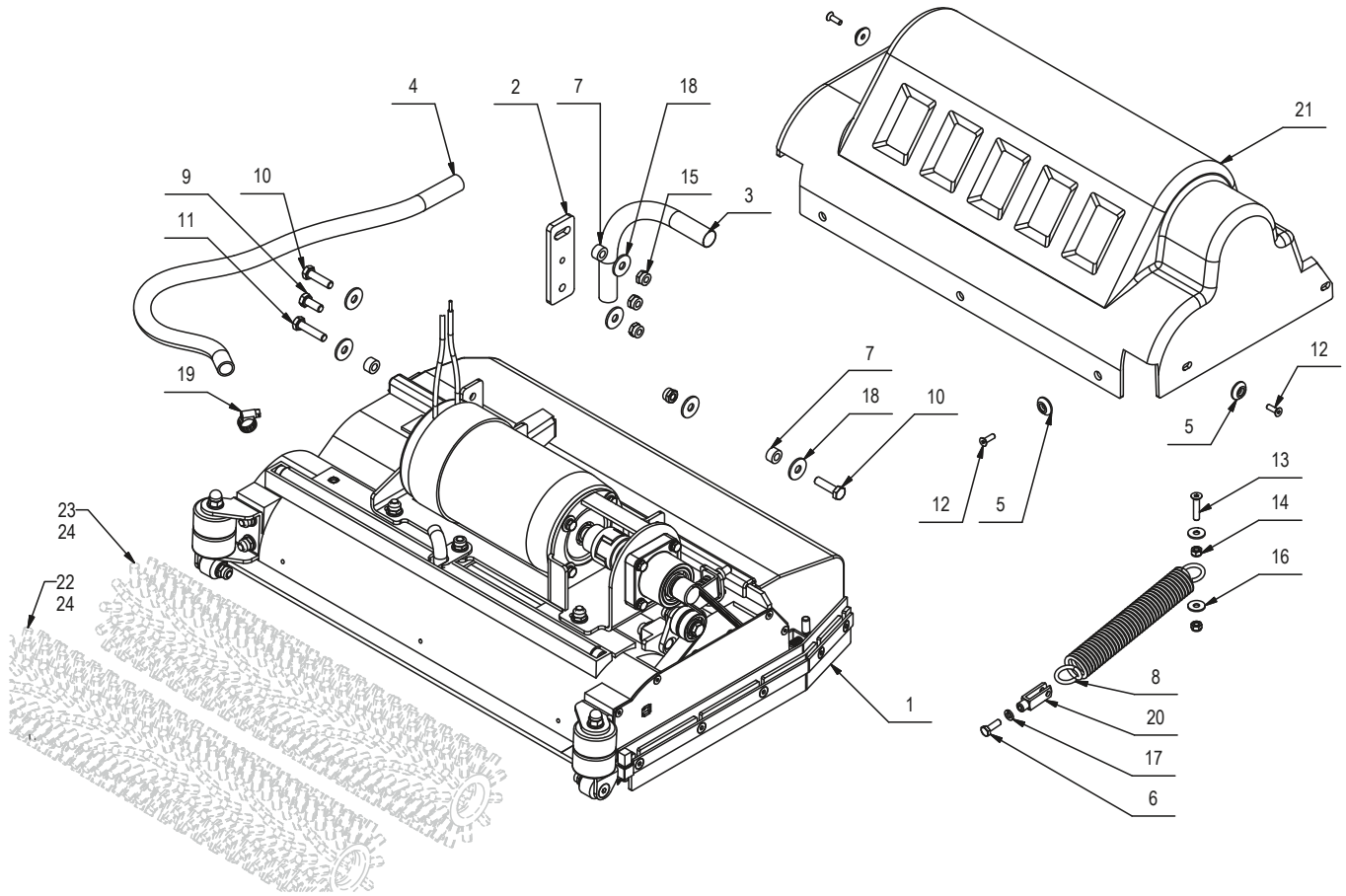

# BRUSH DECK PARTS LISTING

Item#	Part #	Description	Qty.
1	E22156	Brush Base Assembly	1
2	E22157	Mounting Plate	1
3	E22158	Sheath	2
4	E22159	Solution Tube	1
5	E83850	Flat Washer M5x20 SS	7
6	E20088	Hex Bolt M6x18 Zinc	1
7	E83932	Bushing	3
8	E22160	Spring	1
9	E81917	Bolt, Hex, M8x20, Zinc	1
10	E83802	Hex Bolt M8x30 Zinc	2
11	E83801	Hex Bolt M8x35 Zinc	1
12	E20290	Flat Hd Soc Machine Screw M5x16 SS	7

Item#	Part #	Description	Qty.
13	E81773	Screw	1
14	E83550	NyLoc Hex Nut, M6 Zinc	2
15	E86853	Nyloc Hex Nut, M8 Zinc	4
16	E82798	Flat Washer, M6x18x1.5 Zinc	2
17	E82774	Lock Washer, M6 Zinc	1
18	E83404	Flat Washer M9x24x2.5 Zinc	6
19	E85762	Hose Clamp	1
20	E86154	Fork	1
21	E22161	Base Cover	1
22	E82410	Brush, Front Cylindrical, White, 0.5mm PPL	1
23	E82528	Brush, Rear Cylindrical, Blue, 0.3mm PPL	1
24	E22162	Brush, Medium Duty, 0.6mm	2

# BRUSH DRIVE DIAGRAM

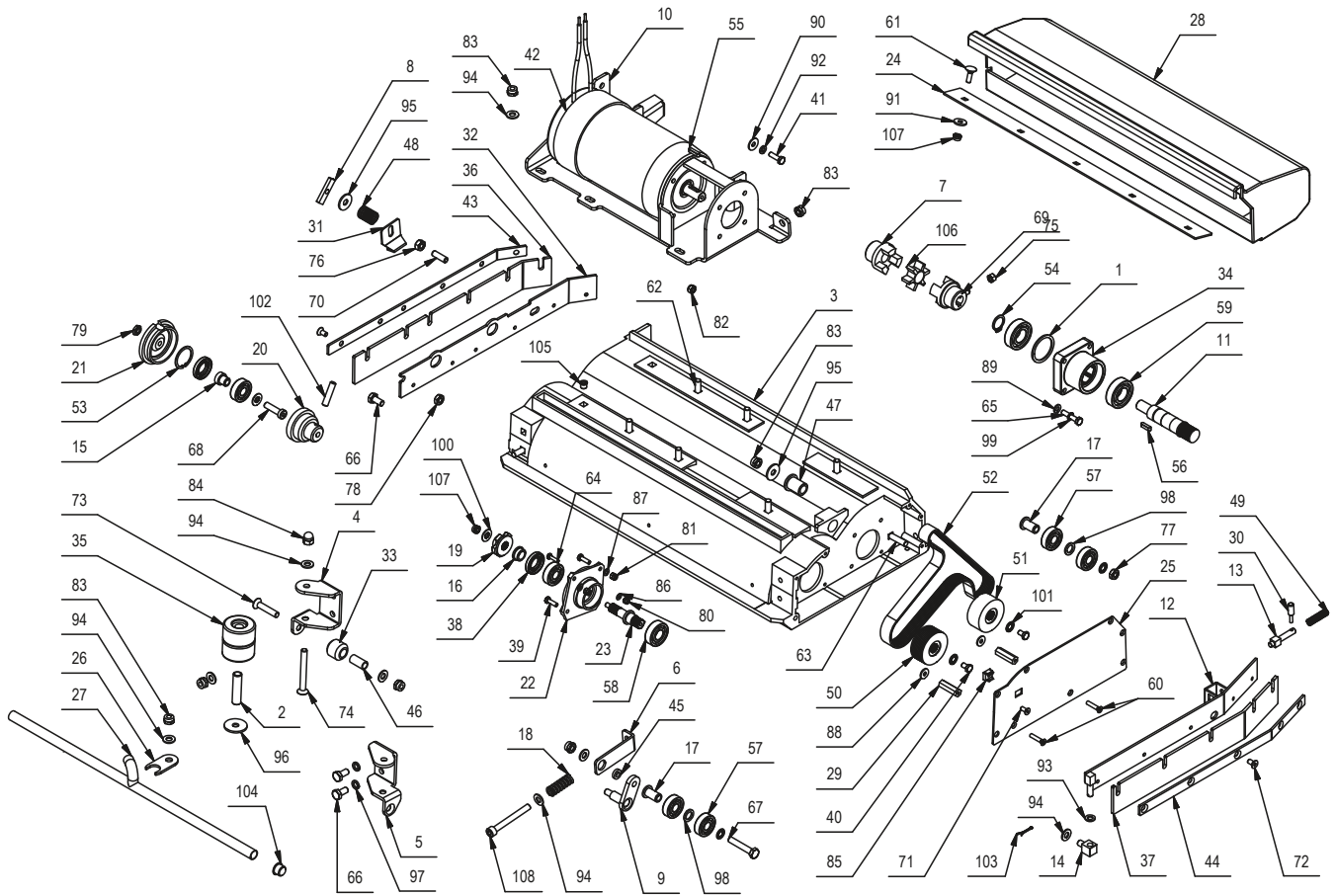

# BRUSH DRIVE PARTS LISTING

Item#	Part #	Description	Qty.	Item#	Part #	Description	Qty.
1	E22163	Spacer	1	55	E83700	Shaft Key 5x5x20mm	1
2	E82701	Tube	2	56	E82399	Shaft Key	1
3	E88445	Brush Deck Housing	1	57	E83905	Bearing, 8201 2RS	8
4	E81818	Bracket Support	1	58	E22181	Bearing, 6202 2RS 15x35x11	2
5	E82674	Bracket Support	1	59	E83923	Bearing, 6004 2RS	2
6	E22164	Support Mount	1	60	E83934	Screw m5x25	2
7	E22165	Hub	2	61	E20234	Carriage Bolt M6x20 SS	5
8	E83337	Knob	1	62	E22182	Bolt, M8 x 25	8
9	E22166	Linkage	1	63	E22183	Bolt, M8 x 35	1
10	E22167	Motor Mount	1	64	E22184	Bolt, M4 x 16	2
11	E82369	Pulley, Motor	1	65	E83974	Hex Bolt M6x30 Zinc	4
12	E82466	Support	1	66	E83795	Hex Bolt M8x16 Zinc	3
13	E82434	Pin	1	67	E83827	Hex Bolt M8x45 Zinc	1
14	E22168	Left Support	1	68	E20288	Soc Hd Cap Screw M8x30 Zinc	2
15	E22169	Bearing Hub	2	69	E22185	Pin	2
16	E83988	Bushing	2	70	E22186	Pin	1
17	E89543	Bushing	2	71	E81963	Flat Hd Soc Machine Screw M5x12 SS	5
18	E22170	Spring	1	72	E83835	Screw M6 x 12	11
19	E82264	Hub, Left	2	73	E81871	Flat Hd Soc Machine Screw M8x40 Zinc	2
20	E22171	Spindle, Right Hub	2	74	E83846	Screw, M8x70	2
21	E22172	Cap, Right Hub	2	75	E20112	Hex Nut, M6x6 Zinc	2
22	E82690	Support	2	76	E83656	Hex Nut, M8x6.5 Zinc	1
23	E82413	Shaft	2	77	E83672	Hex Jam Nut, M8x5 SS	1
24	E81442	Blade	1	78	E82808	Hex Jam Nut, M8X5 Zinc	1
25	E22173	Cover	1	79	E22187	Nut, M8 x 4	2
26	E22174	Plate	1	80	E81649	Nut, Locking M4X6	2
27	E22175	Spray Bar	1	81	E20705	Nyloc Hex Nut, M5 Zinc	4
28	E82407	Hopper, Simpla Cylindrical	1	82	E83550	NyLoc Hex Nut, M6 Zinc	4
29	E22176	Stud Bolt	2	83	E86853	Nyloc Hex Nut, M8 Zinc	13
30	E82442	Pin	1	84	E22295	Dome Hex Nut, M8 Zinc	2
31	E22177	Plate	1	85	E22188	Nut	1
32	E82537	Support	1	86	E83859	Washer	2
33	E83896	Wheel	2	87	E81618	Flat Washer M5x10x1 SS	4
34	E20081	Bearing Block	1	88	E20121	Flat Washer M5x15x1.5 Zinc	2
35	E82451	Wheel 45 OD x 25 W	4	89	E82761	Flat Washer M6x12x1.6 Zinc	4
36	E82331	Splash guard	1	90	E82798	Flat Washer, M6x18x1.5 Zinc	4
37	E82431	Splash guard	1	91	E83799	Flat Washer M6.6x18x2 SS	5
38	E82496	Seal	4	92	E82774	Lock Washer, M6 Zinc	4
39	E20084	Hex Bolt M5x16 SS	6	93	E22189	Washer, 8 x 14 x 1.5	1
40	E83659	Screw	2	94	E81874	Flat Washer M8x17x1.6 Zinc	15
41	E82772	Hex Bolt M6x20 Zinc	4	95	E83404	Flat Washer M9x24x2.5 Zinc	2
42	E88444	Brush Motor Drive	1	96	E81918	Flat Washer M9x32x2.5 Zinc	2
43	E82474	Right Blade	1	97	E83704	Lock Washer M8x13x2.2 Zinc	2
44	E88407	Left Blade	1	98	E83822	Washer	2
45	E22178	SPACER	1	99	E81438	External Serrated Lock Washer M6 Zinc	4
46	E83524	Bushing	2	100	E2219000	Washer	4
47	E83791	Bushing	1	101	E22191	Washer	4
48	E22179	Spring	1	102	E22192	Pin, 0.8 x 35	2
49	E82446	Spring	1	103	E83605	Split pin	1
50	E82418	Pulley	1	104	E20129	Cap	2
51	E82354	Pulley	1	105	E22193	Plug	2
52	E83979	Belt	1	106	E81445	Flexible Coupling	1
53	E83630	Ring	2	107	E82314	Nyloc Hex Nut, M6 SS	7
54	E22180	Snap Ring	1	108	E22322	Soc Hd Cap Screw M8x70 Zinc	1

# BRUSH DECK LIFT DIAGRAM

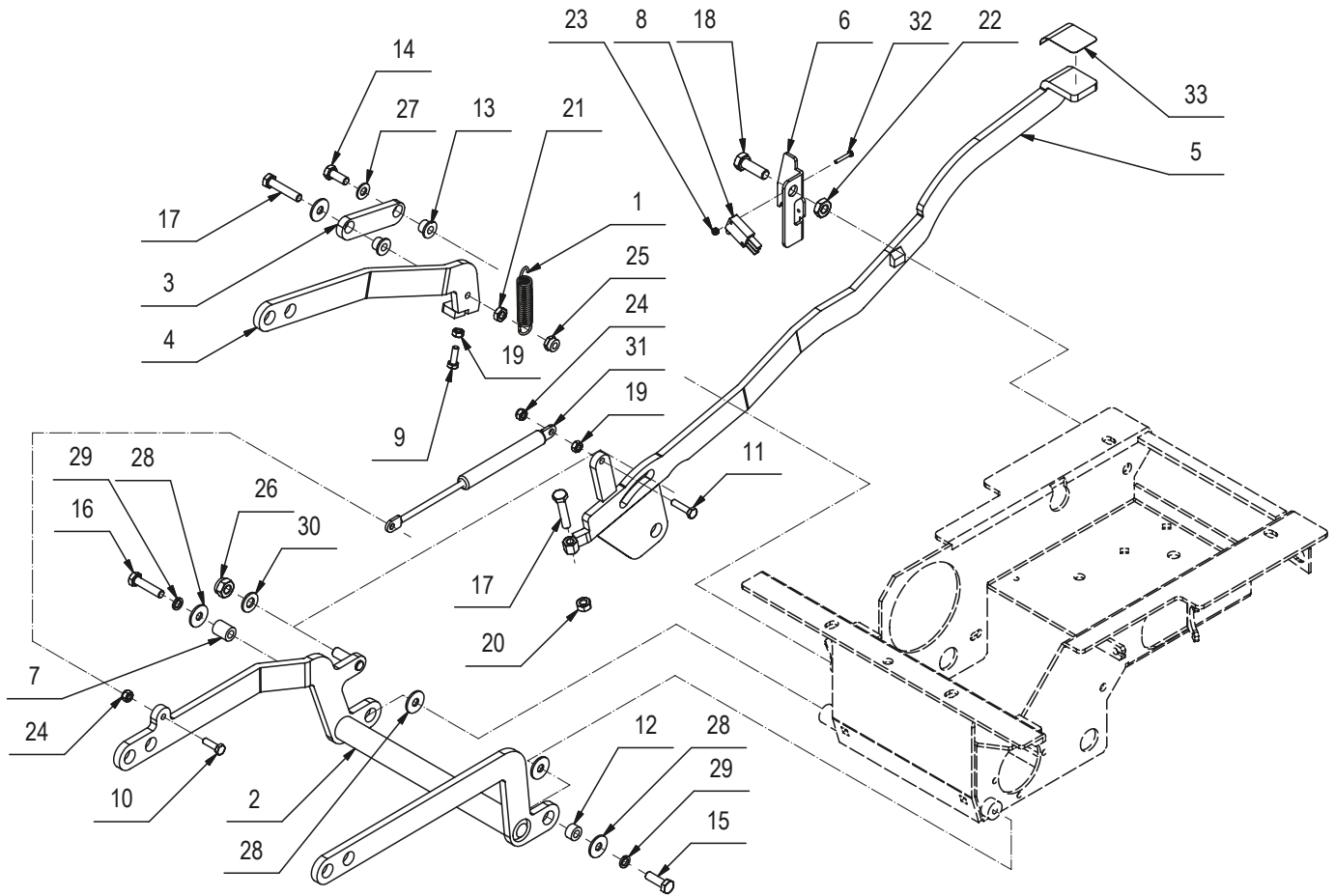

## BRUSH DECK LIFT PARTS LISTING

Item#	Part #	Description	Qty.
1	E82689	Spring, 15x2x60mm Galv Extension	1
2	E20219	Brush Deck Lift Arm Weldment	1
3	E20220	Brush Deck Lift Arm Linkage	1
4	E20062	Brush Deck Lift Idler Arm	1
5	E20282	Brush Deck Lift Foot Pedal	1
6	E20283	Foot Pedal Latch Plate	1
7	E20063	Bushing	1
8	E88279	Micro Switch Sealed	1
9	E20088	Hex Bolt M6x18 Zinc	1
10	E82772	Hex Bolt M6x20 Zinc	1
11	E20090	Hex Bolt M6x25 Zinc	1
12	E83932	Bushing	1
13	E82285	Bushing	2
14	E81917	Hex Bolt M8x20 Zinc	1
15	E83833	Hex Bolt M8x25 Zinc	1
16	E83801	Hex Bolt M8x35 Zinc	1
17	E83830	Hex Bolt M8x40 Zinc	2

Item#	Part #	Description	Qty.
18	E88011	Hex Bolt, M10 x 30 Zinc	1
19	E83852	Hex Nut, M6x5	2
20	E83656	Hex Nut, M8x6.5 Zinc	1
21	E82808	Hex Jam Nut, M8X5 Zinc	1
22	E83875	Hex Jam Nut, M10X6 Zinc	1
23	E81673	Hex Nyloc Nut, M3 Zinc	2
24	E83550	NyLoc Hex Nut, M6 Zinc	2
25	E86853	Nyloc Hex Nut, M8 Zinc	1
26	E83381	Nyloc Hex Nut, M10 Zinc	1
27	E81874	Flat Washer M8x17x1.6 Zinc	1
28	E83404	Flat Washer M9x24x2.5 Zinc	5
29	E83704	Lock Washer M8x13x2.2 Zinc	2
30	E82773	Flat Washer M10x21x2 Zinc	1
31	E20130	Shock Absorber	1
32	E20533	Hex Bolt M3x20 SS	2
33	E20635	Abrasive Antislip Tape	1

# SQUEEGEE ASSEMBLY DIAGRAM

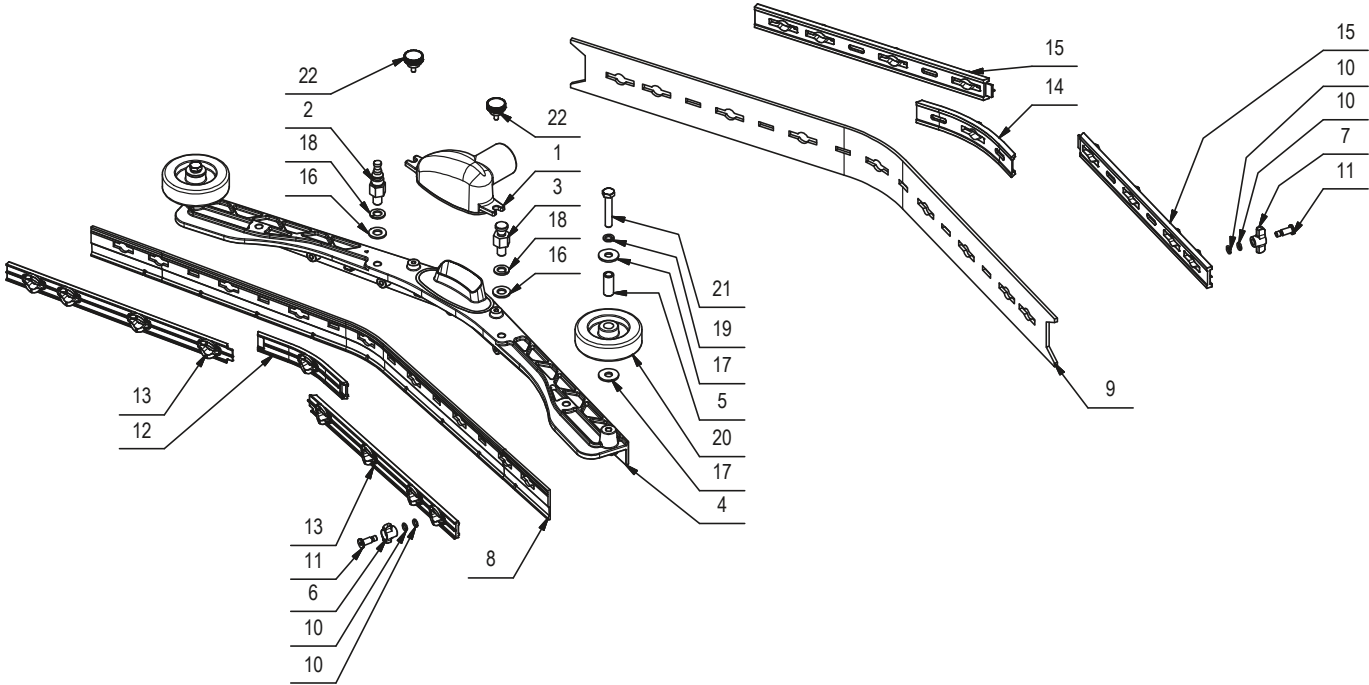

## SQUEEGEE ASSEMBLY PARTS LISTING

Item#	Part #	Description	Qty.
1	E89837	Squeegee Vacuum Adapter (H)	1
2	E82275	Pin, Adjustable Mounting M10 Zinc	1
3	E82280	Pin, Fixed Mounting M10 Zinc	1
4	E22633	Squeegee Body	1
5	E88442	Bushing, Steel, 12mm OD, 8mm ID, 28mm L	2
6	E22358	Wing Nut Knob	9
7	E22359	Wing Nut Knob	9
8	E22636	Front Squeegee Blade, Polyurethane 31" x 1 1/2" x 1/8"	1
9	E22637	Wiping Squeegee Blade, Gum Rubber 33 1/2" x 1 3/4" x 1/8"	1
10	E22385	O-Ring 7mm	36
11	E22346	Custom Cap Screw	18

Item#	Part #	Description	Qty.
12	E22352	Center Front Squeegee Blade Clamp	1
13	E22635	Front Squeegee Blade Clamp	2
14	E22355	Center Rear Squeegee Blade Clamp	1
15	E22634	Rear Squeegee Blade Clamp	2
16	E86255	Flat Washer M10x21x2 SS	2
17	E86164	Flat Washer M9x24x2.5 SS	4
18	E20128	Lock Washer M10 SS	2
19	E20252	Lock Washer M8x13x2.2 SS	2
20	E88280	Wheel 80 x 23 Superlan Grey	2
21	E20287	Hex Bolt M8x45 SS	2
22	E22630	Thumb Screw	2

# SQUEEGEE YOKE DIAGRAM

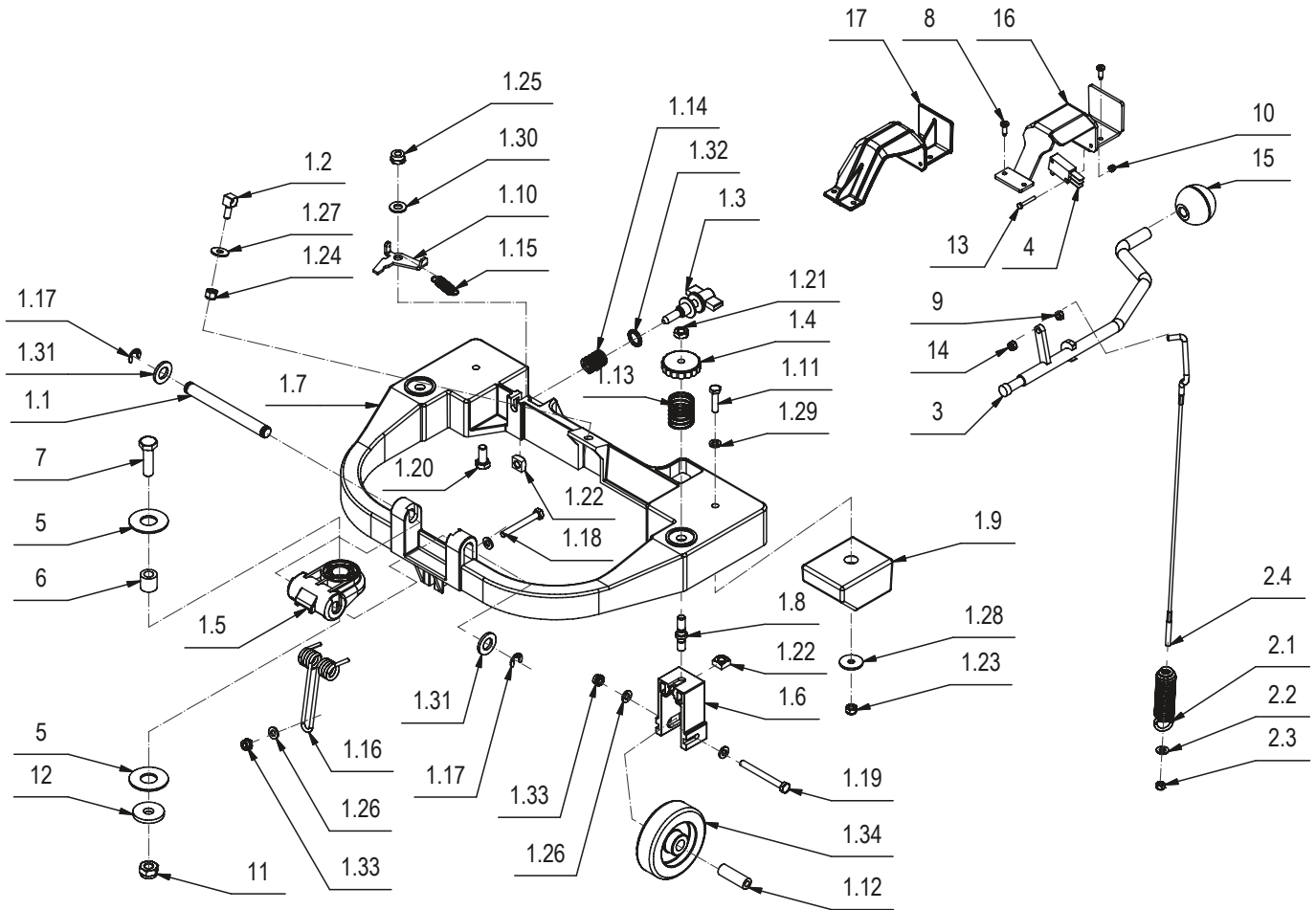

# SQUEEGEE YOKE PARTS LISTING

Item#	Part #	Description	Qty.
1	E20623	Squeegee Yoke ASM	1
1.1	E20010	Pivot Pin	1
1.2	E82389	Tie Rod, M6 Square Head Zinc	1
1.3	E82265	Knob, Squeegee Pitch Adjustment	1
1.4	E83331	Knob, M8 Round Nylon Female	2
1.5	E85776	Pivot Connector	1
1.6	E20078	Squeegee Wheel Support	2
1.7	E81880	Squeegee Yoke	1
1.8	E20079	Threaded Adjuster Rod	2
1.9	E20080	Ballast	2
1.10	E86252	Latch, Squeegee Connector	1
1.11	E20090	Hex Bolt M6x25 Zinc	2
1.12	E82274	Bushing	2
1.13	E20091	Spring	2
1.14	E82703	Spring, 16.6x2x23mm Galv Compression	1
1.15	E82453	Spring, 10x1.1x38 SS Extension	1
1.16	E86158	Spring, 86mm Galv Torsion Custom	1
1.17	E85498	E Style Circlip	2
1.18	E86159	Hex Bolt M6x50 Zinc	1
1.19	E83866	Hex Bolt M6x60 SS	2
1.20	E20098	Hex Bolt M8x18 Zinc	1
1.21	E83672	Hex Jam Nut, M8x5 SS	2
1.22	E83824	Square Nut, M8 SS	3
1.23	E83550	NyLoc Hex Nut, M6 Zinc	2
1.24	E83550	NyLoc Hex Nut, M6 Zinc	1
1.25	E86853	Nyloc Hex Nut, M8 Zinc	1
1.26	E82761	Washer 6x12x1.6	6
1.27	E82798	Washer, 6x18x1.5	1

Item#	Part #	Description	Qty.
1.28	E83278	Flat Washer M6.5x24x2 Zinc	2
1.29	E82774	Lock Washer, M6 Zinc	2
1.30	E88238	Flat Washer, M8x17x1.6 SS	1
1.31	E85722	Flat Washer M13x24x2.5 Zinc	2
1.32	E81406	External Serrated Lock Washer M13x18 Zinc	1
1.33	E82314	Nyloc Hex Nut, M6 SS	3
1.34	E88280	Wheel 80 OD x 23 W	2
2	E88278	Squeegee Lift Rod ASM	1
2.1	E82279	Spring, 20x3x48mm Custom Galv Extension	1
2.2	E82761	Washer 6x12x1.6	1
2.3	E20382	Nyloc Hex Nut, M5 x 5 Zinc	1
2.4	E88250	Squeegee Lift Cable	1
3	E20313	Squeegee Lift Lever	1
4	E88279	Micro Switch Sealed	1
5	E20337	Flat Washer M17x40x2 Delrin	2
6	E20231	Bushing	1
7	E82455	Hex Bolt M10x35 Zinc	1
8	E83838	Screw, Flat Hd M4x15 Zinc	4
9	E82317	Hex Jam Nut, M5X3.5 Zinc	1
10	E81673	Hex Nyloc Nut, M3 Zinc	2
11	E83381	Nyloc Hex Nut, M10 Zinc	1
12	E20295	Flat Washer M10.5x32x4Zinc	1
13	E20533	Hex Bolt M3x20 SS	2
14	E20382	Nyloc Hex Nut, M5 x 5 Zinc	1
15	E20638	Knob	1
16	E20641	Bracket	1
17	E20641	Bracket	1

# MAIN FRAME DIAGRAM

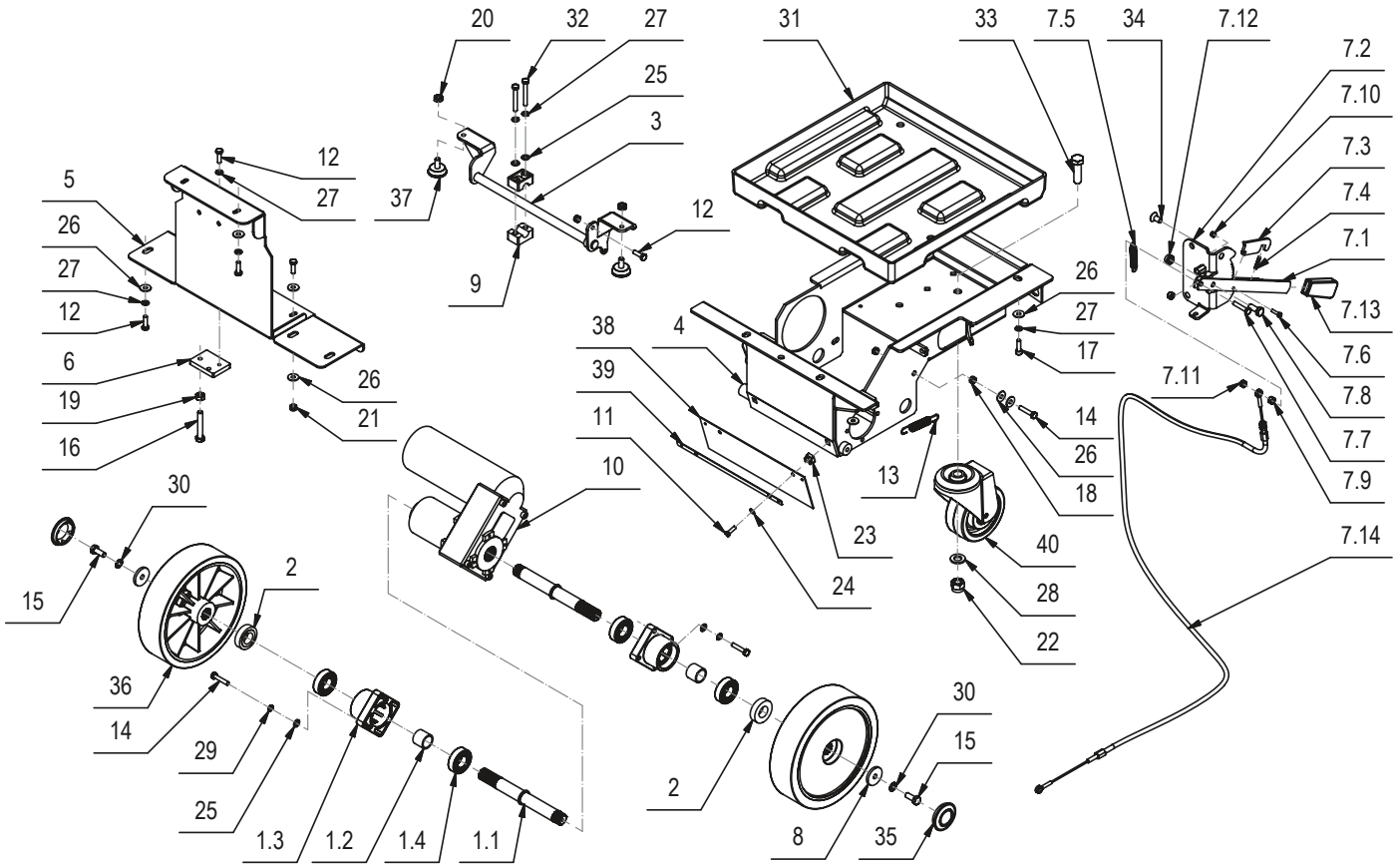

# MAIN FRAME PARTS LISTING

Item#	Part #	Description	Qty.
1	E20003	Axle Shaft ASM	2
1.1	E20478	Axle Shaft	1
1.2	E20482	Spacer	1
1.3	E20081	Bearing Block	1
1.4	E83923	Bearing	2
2	E20013	Spacer	2
3	E20492	Brake Arm Weldment	1
4	E20407	Main Frame Weldment	1
5	E20221	Frame Bracket	1
6	E20222	Plate	1
7	E20518	Brake Lever ASM	1
7.1	E20595	Brake Lever	1
7.2	E20522	Brake Lever Bracket	1
7.3	E81928	Latch Lock	1
7.4	E82255	Spring	1
7.5	E83491	Spring	1
7.6	E20341	Hex Bolt M4x16 Zinc	1
7.7	E83974	Hex Bolt M6x30 Zinc	1
7.8	E81917	Hex Bolt M8x20 Zinc	1
7.9	E20112	Hex Nut, M6x6 Zinc	2
7.10	E83867	Nyloc Hex Nut, M4x6 Zinc	1
7.11	E83550	NyLoc Hex Nut, M6 Zinc	1
7.12	E81709	Nyloc Hex Nut, M8 Zinc	1
7.13	E20423	Brake Handle Grip	1
7.14	E20537	Brake Cable	1
8	E81915	Flat Washer M8.2x32x4 Zinc	2
9	E82834	Pivot Block	4
10	E86182	Drive Motor 24VDC 150W	1
11	E20084	Hex Bolt M5x16 SS	2

Item#	Part #	Description	Qty.
12	E82772	Hex Bolt M6x20 Zinc	7
13	E81056	Spring	1
14	E83974	Hex Bolt M6x30 Zinc	9
15	E81917	Hex Bolt M8x20 Zinc	2
16	E87285	Hex Bolt M8x50 Zinc	1
17	E20489	Soc Hd Cap Screw M6x20 Zinc	2
18	E83852	Hex Nut, M6x5	2
19	E83656	Hex Nut, M8x6.5 Zinc	1
20	E82808	Hex Jam Nut, M8X5 Zinc	2
21	E83550	NyLoc Hex Nut, M6 Zinc	2
22	E20249	Nyloc Hex Nut, M12x15 Zinc	1
23	E20250	Cage Nut M5	2
24	E81618	Flat Washer M5x10x1 SS	2
25	E82761	Flat Washer M6x12x1.6 Zinc	12
26	E82798	Flat Washer M6x18x1.5 Zinc	11
27	E82774	Flat Washer M6x12x1.6 SS	11
28	E85722	Flat Washer M13x24x2.5 Zinc	1
29	E81438	External Serrated Lock Washer M6 Zinc	8
30	E83868	External Serrated Lock Washer M8 Zinc	2
31	E88002	Battery Tray	1
32	E20360	Hex Bolt M6x45 Zinc	4
33	E20379	Hex Bolt M12x40 Zinc	1
34	E20297	Flat Hd Soc Machine Screw M8x16 Zinc	2
35	E81971	Wheel Cap	2
36	E88282	Wheel 200 OD x 50 W	2
37	E20175	Brake Pad M8x17	2
38	E88283	Chassis Splash Guard	1
39	E20176	Band Clamp	1
40	E20177	Caster	1

# TANK ASSEMBLY DIAGRAM

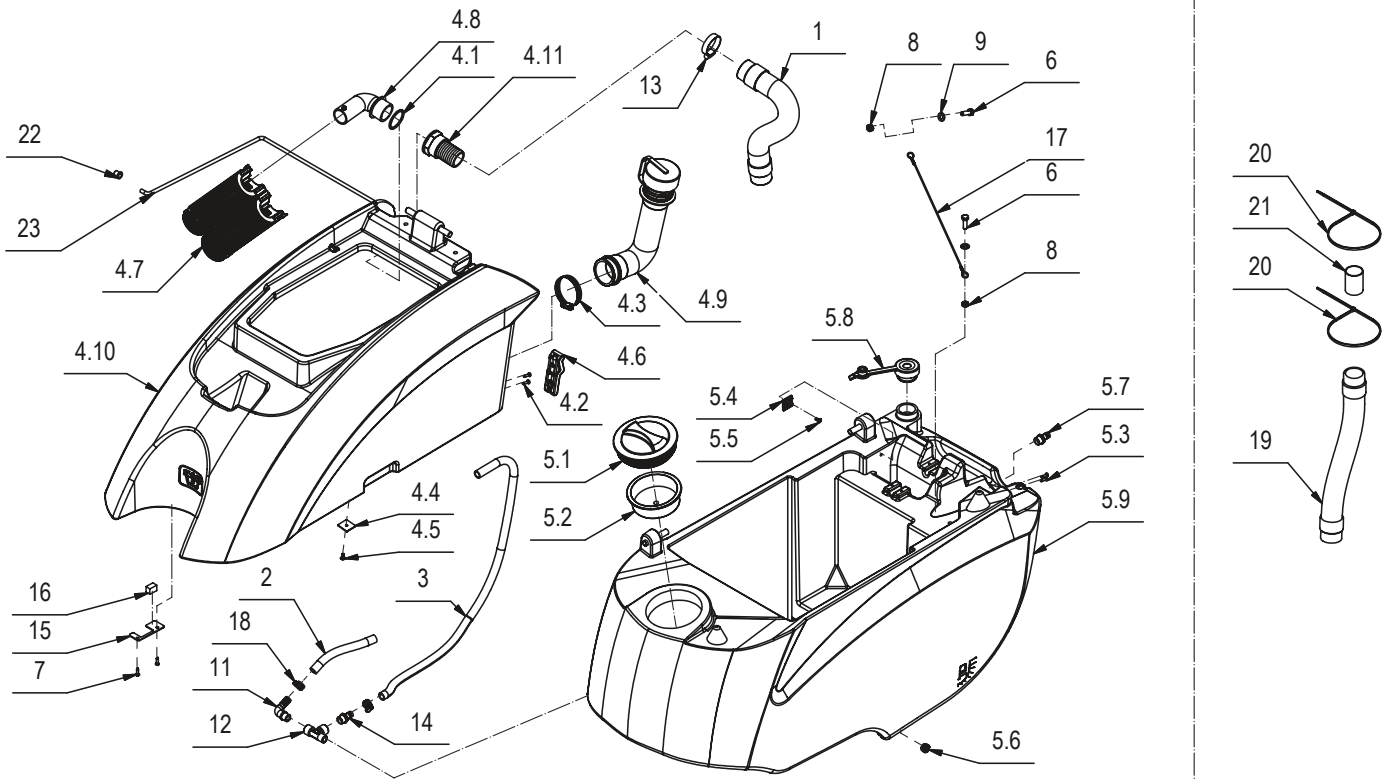

# TANK ASSEMBLY PARTS LISTING

Item#	Part #	Description	Qty.
1	E88499	Hose, Vacuum	1
2	E20004	Tubing 12 ID x 200 L	1
3	E88288	Hose, Glass Reinforced 17 OD x 12 ID x 820 L	1
4	E20228	Recovery Tank Assembly	1
4.1	E82341	Gasket	1
4.2	E20107	Screw, Pan Hd Phil Self Tap M4.2x16 SS	2
4.3	E20432	Hose Clamp	1
4.4	E88164	Male Connector 1/4 x 1/2 for Simpla 20	1
4.5	E20468	Flat Hd Phil Machine Screw M5x12 Zinc	1
4.6	E20413	Latch	1
4.7	E88285	Filter, Cage	1
4.8	E20186	Elbow	1
4.9	E88286	Hose, Drain	1
4.10	E20202	Recovery Tank	1
4.11	E20189	Fitting, Threaded Nylon	1
5	E20376	Solution Tank Assembly	1
5.1	E82429	Cap	1
5.2	E82612	Filter	1
5.3	E20107	Screw, Pan Hd Phil Self Tap M4.2x16 SS	2
5.4	E88164	Male Connector 1/4 x 1/2 for Simpla 20	1
5.5	E20468	Flat Hd Phil Machine Screw M5x12 Zinc	1

Item#	Part #	Description	Qty.
5.6	E20627	Plug, 3/8" Male	1
5.7	E82269	Barbed Fitting, 3/8 in.	1
5.8	E20185	Cap	1
5.9	E20201	Soltuion Tank	1
6	E83833	Hex Bolt M8x25 Zinc	2
7	E20107	Screw, Pan Hd Phil Self Tap M4.2x16 SS	4
8	E82808	Hex Jam Nut, M8X5 Zinc	2
9	E20127	Flat Washer M9x18x1.5 Zinc	2
11	E86275	Barbed Elbow, 3/8"	1
12	E20651	T-Fitting, 3/8" Male/Double Female Nylon	1
13	E20325	Hose Clamp	1
14	E82269	Barbed Fitting, 3/8 in.	1
15	E20399	Pivot Plate	2
16	E20190	Spacer Block	2
17	E88260	Lanyard	1
18	E85762	Hose Clamp	2
19	E88499	Hose, Vacuum	1
20	E83920	Clamp 9x300 4,8x360 black	2
21	E88500	Fitting, Hose D38, W1.5, L50	1
22	E22074	Plug, Vac Lid Bale	2
23	E22072	Bale, Vac Lid	1

# VACUUM UNIT DIAGRAM

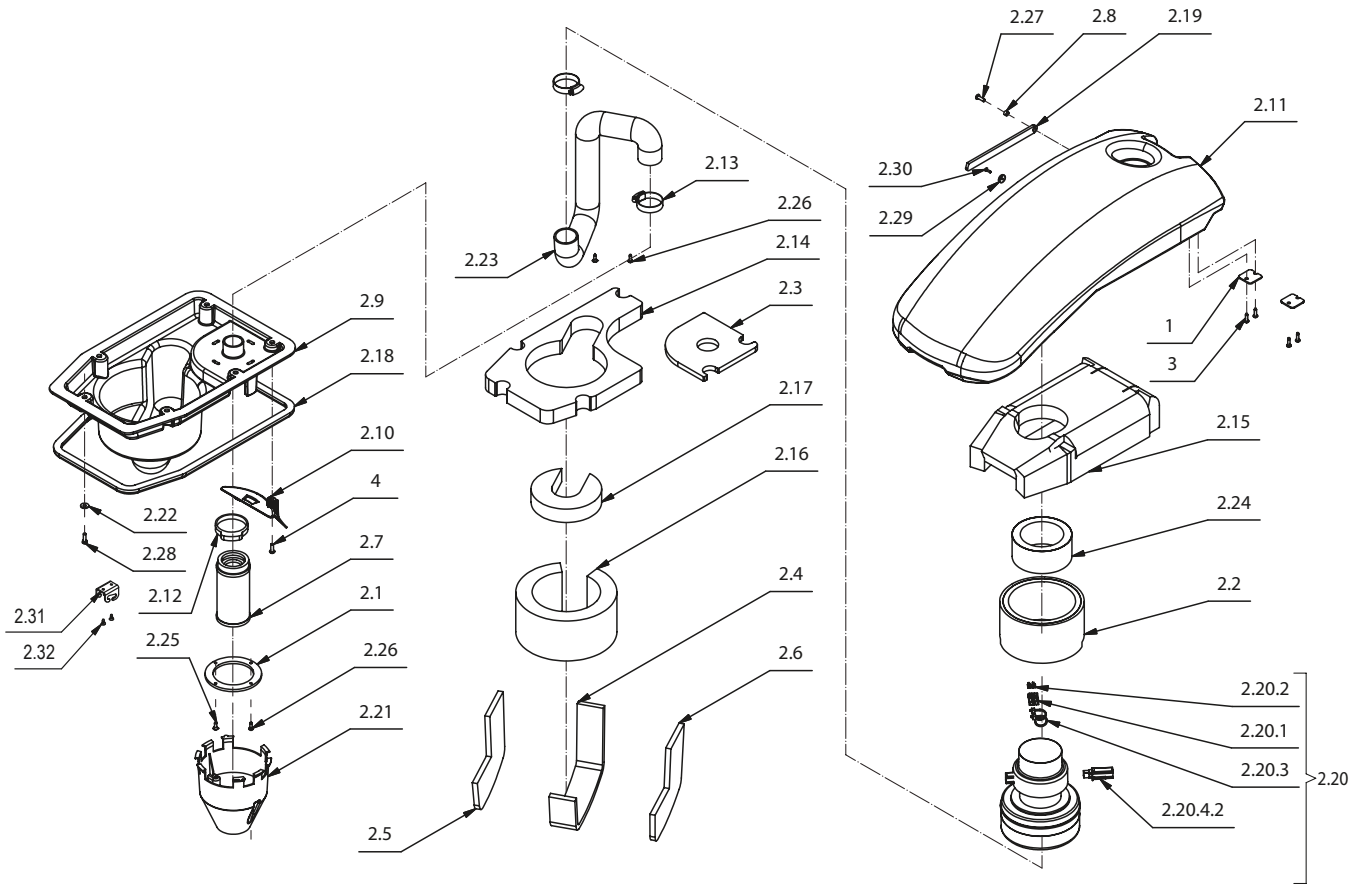

# VACUUM UNIT PARTS LISTING

Item#	Part #	Description	Qty.
1	E20265	Plate	2
2	E20066	Recovery Tank Cover ASM	1
2.1	E20305	Mounting Ring	1
2.2	E20652	Sound Deadening Foam	1
2.3	E20180	Sound Deadening Foam	1
2.4	E20179	Sound Deadening Foam	1
2.5	E20178	Sound Deadening Foam	1
2.6	E20266	Sound Deadening Foam	1
2.7	E88292	"Filter, Cage"	1
2.8	E20486	Bushing	1
2.9	E20384	Vacuum Motor Cover	1
2.10	E20191	Deflector	1
2.11	E20199	Recovery Tank Cover	1
2.12	E81710	Hose Clamp	1
2.13	E20325	Hose Clamp	2
2.14	E20181	Sound Deadening Foam	1
2.15	E20184	Sound Deadening Foam	1
2.16	E20183	Sound Deadening Foam	1
2.17	E20182	Sound Deadening Foam	1
2.18	E88289	Gasket	1

Item#	Part #	Description	Qty.
2.19	E20064	Support Bracket	1
2.20	E88291	Vacuum Motor 36VDC 550W	1
2.20.1	E83897	Connector, Electrical Housing 30A	2
2.20.2	E83883	Lug, Electrical 30A	2
2.20.3	E83935	Wire Tie	2
2.20.4	E88291	Vacuum Motor 36VDC 550W	1
2.20.4.1	E88291	Vacuum Motor 36VDC 550W	1
2.20.4.2	E20525	Carbon Brush	2
2.21	E81006	Vacuum Splash Guard	1
2.22	E20122	Flat Washer M5 x 15 x 1.5 SS	5
2.23	E88290	Hose, Vacuum 1-1/2" x 22-1/4"	1
2.24	E20440	Sound Deadening Foam	1
2.25	E83796	Screw, Pan Hd Phil Self Tap M4.2x16 Zinc	2
2.26	E83838	Screw, Flat Hd M4x15 Zinc	2
2.27	E20442	Button Hd Soc Machine Screw M5x16 Zinc	1
2.28	E20084	Hex Bolt M5x16 SS	5
2.29	E20712	Magnet	1
2.30	E20192	CHIPBOARD SCREW M3x12 Zinc	1
2.31	E22075	Hook, Vac Lid Bale	1
2.32	E22076	Screw, M4 x 10	2

# SOLUTION CONTROL DIAGRAM

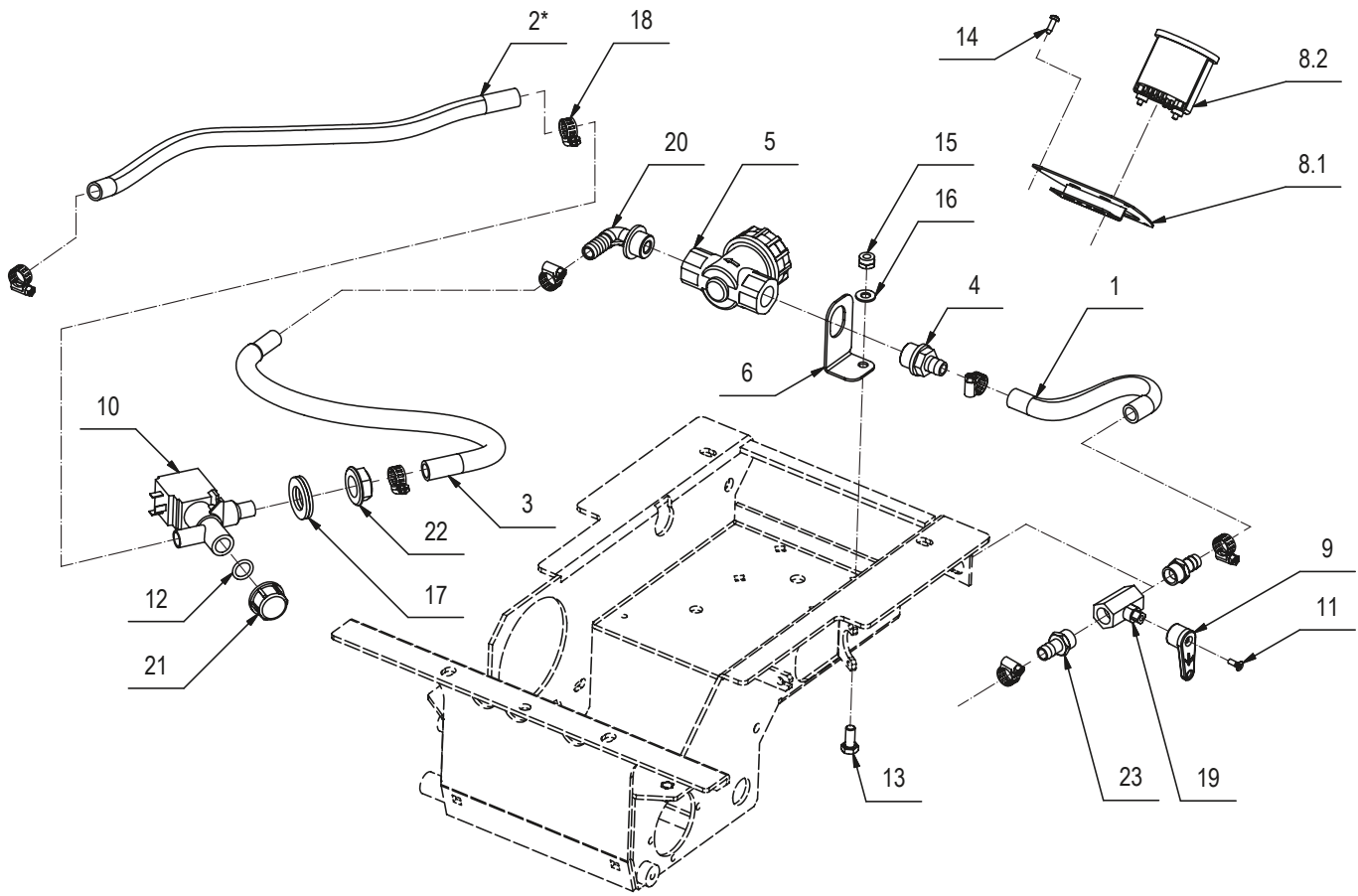

## SOLUTION CONTROL PARTS LISTING

Item#	Part #	Description	Qty.
1	E20004	Tubing 12 ID x 200 L	1
2	E20530	Tubing 12 ID x 460 L	1
3	E82693	Hose, 17 OD x 12 ID x L 420	1
4	E82447	Fitting, 1/2" NPT & 1/2" Barbed Nylon	1
5	E88207	Filter Assembly, Inline Double Female 1/2" NPT	1
6	E20457	Bracket	1
8	E20463	Instrument Panel ASM	1
8.1	E20332	Panel	1
8.2	E88293	Battery Check Card, Hour Meter	1
9	E82705	Valve Lever	1
10	E82322	Solenoid Valve, 24v 10w 3-Port Nylon	1
11	E83858	Oval Hd SL Machine Screw M4x12 SS	1

Item#	Part #	Description	Qty.
12	E83617	O-Ring, 14x2.5mm Buna-N	1
13	E20098	Hex Bolt M8x18 Zinc	1
14	E83838	Screw, Flat Hd M4x15 Zinc	4
15	E86853	Nyloc Hex Nut, M8 Zinc	1
16	E81874	Flat Washer M8x17x1.6 Zinc	1
17	E20253	Flat Washer M21x60x3 Nylon	2
18	E85762	Hose Clamp	7
19	E83361	Ball Valve, 5/8 Double Female	1
20	E81446	Fitting, 1/2" NPT & 1/2" Barbed Nylon Elbow	1
21	E83616	Cap, 1/2" NPT Nylon	1
22	E20433	Ring Nut 1/2"	1
23	E82269	Barbed Fitting, 3/8 in.	2

# HANDLEBAR DIAGRAM

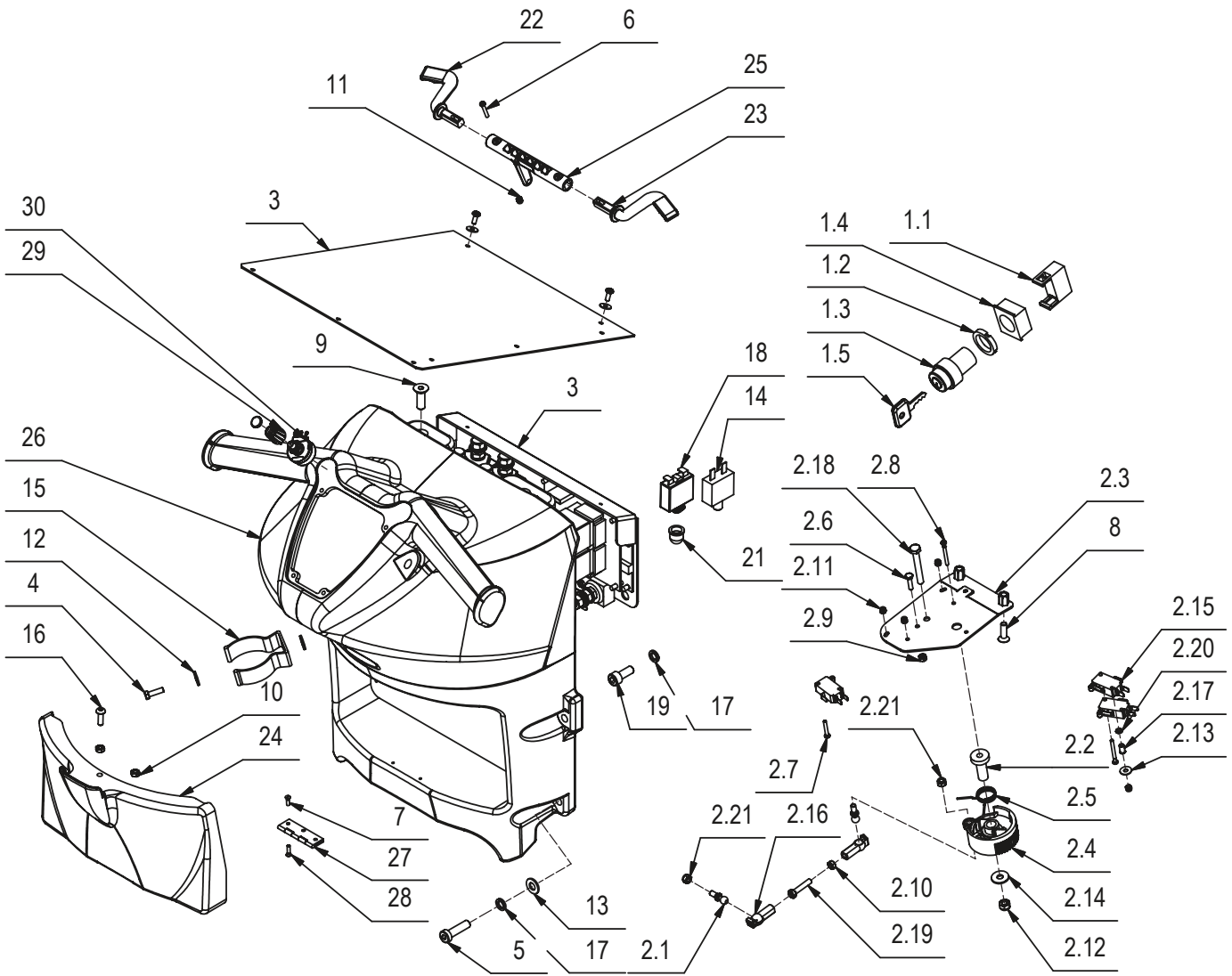

# HANDLEBAR PARTS LISTING

Item#	Part #	Description	Qty.
1	E82351	Key Switch Assembly w/Keys	1
1.1	E83173	Contact, Key Switch	1
1.2	E83316	Key Switch	1
1.3	E83316	Key Switch	1
1.4	E81358	Switch Flange	1
1.5	E83315	Switch Key	1
2	E20223	Drive Control	1
2.1	E20330	Ball Stud M10x22.5	2
2.2	E81597	Circuit Breaker 10 amp, 1/4" Tab Terminals	1
2.3	E20556	Plate	1
2.4	E81763	Cam	1
2.5	E82304	Spring, 20.2x1.3x20.8mm Steel Torsion	1
2.6	E20341	Hex Bolt M4x16 Zinc	1
2.7	E20242	Pan Hd Phil Machine Screw M3x20 Zinc	2
2.8	E20243	Pan Hd Phil Machine Screw M3x30 Zinc	2
2.9	E20248	Hex Nut, M4x4 Zinc	1
2.10	E82317	Hex Jam Nut, M5X3.5 Zinc	2
2.11	E81673	Hex Nyloc Nut, M3 Zinc	4
2.12	E83550	NyLoc Hex Nut, M6 Zinc	1
2.13	E83037	Flat Washer M4x12x1.6 Zinc	1
2.14	E82798	Flat Washer, M6x18x1.5 Zinc	1
2.15	E82270	Micro Switch	3
2.16	E81625	Shank, M5x32 Female Threaded Nylon	2
2.17	E20466	Insert, M3x9 Zinc	1
2.18	E20360	Hex Bolt M6x45 Zinc	1
2.19	E20362	Set Screw Hex Soc Dog Point M5x30 Zinc	1
2.20	E20469	Flat Washer M3 SS	2
2.21	E20382	Nyloc Hex Nut, M5 x 5 Zinc	2

Item#	Part #	Description	Qty.
3	E20625	Electrical Control Panel ASM	1
4	E83836	Hex Bolt M5x16 Zinc	1
5	E20288	Soc Hd Cap Screw M8x30 Zinc	4
6	E20242	Pan Hd Phil Machine Screw M3x20 Zinc	2
7	E81672	Flat Hd SL Machine Screw M3x10 SS	2
8	E20111	Flat Hd Soc Machine Screw M6x20 Zinc	2
9	E20346	Flat Hd Soc Machine Screw M8x25 SS	2
10	E82317	Hex Jam Nut, M5X3.5 Zinc	2
11	E81673	Hex Nyloc Nut, M3 Zinc	2
12	E20121	Flat Washer M5x15x1.5 Zinc	2
13	E81874	Flat Washer M8x17x1.6 Zinc	4
14	E83959	Circuit Breaker 20A	1
15	E87296	Drain Hose Clip	1
16	E20442	Button Hd Soc Machine Screw M5x16 Zinc	1
17	E81046	Lock Washer M8 Zinc	7
18	E83952	Circuit Breaker 30A	1
19	E20614	Soc Hd Cap Screw M8x20 Zinc	3
20	E88299	Cover, Thermal Switch	1
21	E20576	Cap, M10x13 Threaded Poly	1
22	E88300	Lever, Left Switch	1
23	E88301	Lever, Right Switch	1
24	E20267	Door	1
25	E88267	Switch Cam	1
26	E20200	Handlebar Housing	1
27	E20400	Hinge	1
28	E20192	CHIPBOARD SCREW M3x12 Zinc	2
29	E88408	Knob	1
30	E20713	Potentiometer	1



# ELECTRICAL COMPONENTS PARTS LISTING

Item#	Part #	Description	Qty.
1	E20065	Bracket	1
2	E20646	Chopper Card	1
3	E83628	Contactora 24VDC	2
4	E83159	Relay 24VDC 20A	2
5	E20097	Hex Bolt M8x40 SS	2
6	E20248	Hex Nut, M4x4 Zinc	2
7	E83672	Hex Jam Nut, M8x5 SS	2
8	E20115	Hex Nut, M8x6.5 Brass	4
9	E20479	Spring Nut M5	2
10	E81738	Flat Washer M4x12x3 Zinc	2
11	E20124	Flat Washer M8x17x1.6 SS	6
12	E20252	Lock Washer M8x13x2.2 SS	2

Item#	Part #	Description	Qty.
13	E20377	Rivet, M2.4x8 AL	2
14	E20484	Fuse Block	1
15	E83170	Fuse, 80 Amp	1
16	E20448	Bracket	1
17	E20129	Cap	4
18	E20468	Flat Hd Phil Machine Screw M5x12 Zinc	5
19	E81998	Pan Hd Phil Machine Screw M4x10 SS	2
20	E20475	Lock Washer M4 Zinc	2
21	E20301	Flat Hd Phil Machine Screw M4x20 Zinc	2
22	E88456	Electrical Cover Rubber Flap	1
24	E20368	Resistor	1

# ELECTRICAL DIAGRAM

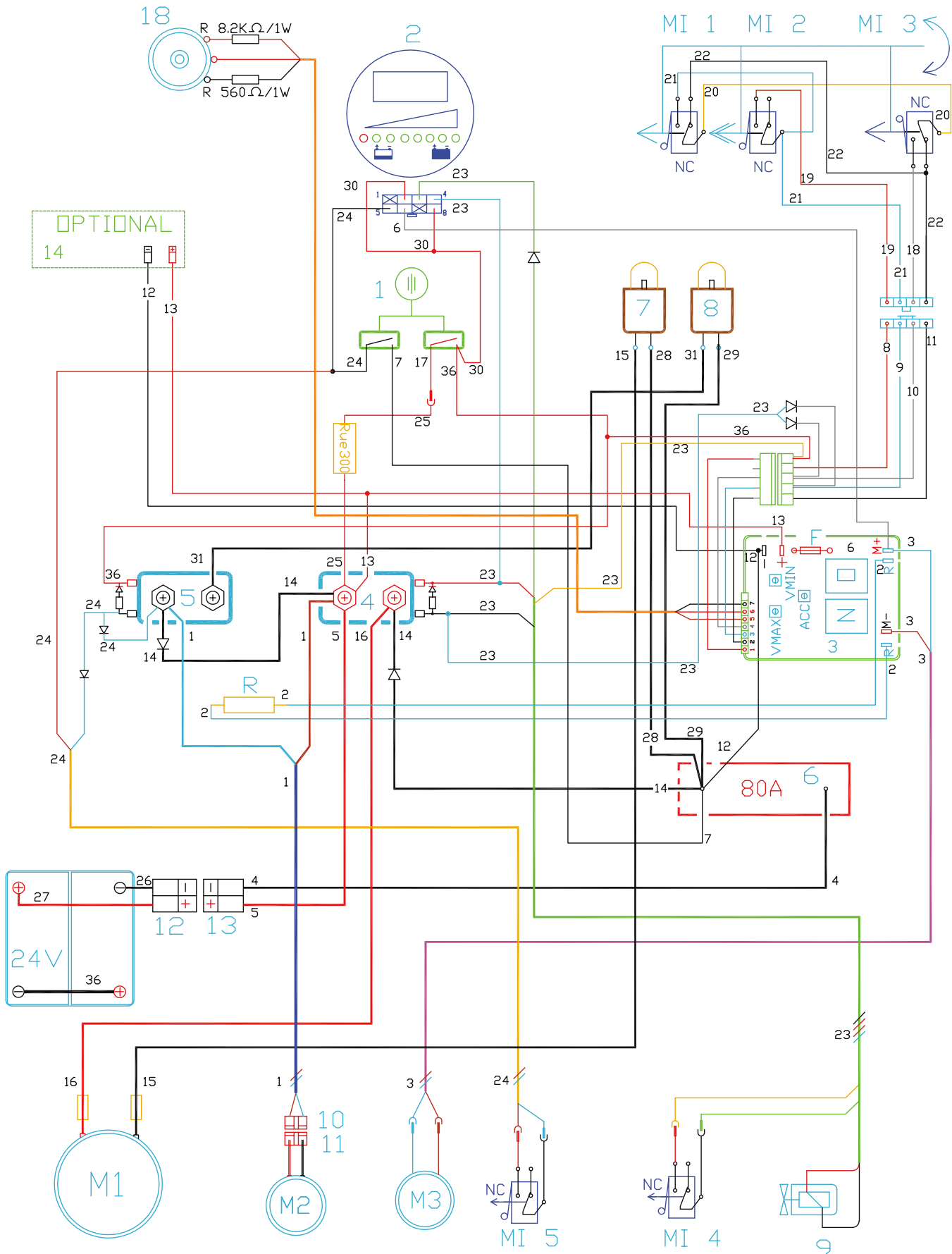

# ELECTRICAL LISTING

<b>Item#</b>	<b>Part #</b>	<b>Description</b>
1	E82351	Key Switch
2	E88293	Hour Meter
3	E20646	Chopper Card
4	E83628	Contactora 24VDC
5	E83628	Contactora 24VDC
6	E83170	Fuse, 80 Amp
7	E83952	Circuit Breaker 30A
8	E83959	Circuit Breaker 20A
9	E82322	Solenoid Valve
9A	E81035	Solenoid Valve
10	E20402	Electrical Connector 30A
11	E20402	Electrical Connector 30A

<b>Item#</b>	<b>Part #</b>	<b>Description</b>
12	E20619	SB175 Red Electrical Connector
13	E20619	SB175 Red Electrical Connector
F	E83972	Fuse 30A fasten
N	E83159	Relay 24VDC 20A
R	E20368	Resistor
MI 1	E82270	Micro Switch
MI 2	E82270	Micro Switch
MI 3	E82270	Micro Switch
MI 4	E88249	Micro Switch
MI 5	E88249	Micro Switch
M2	E88291	Vacuum Motor 36VDC 550W
M3	E86182	Drive Motor 24VDC 150W

# ELECTRICAL DIAGRAM

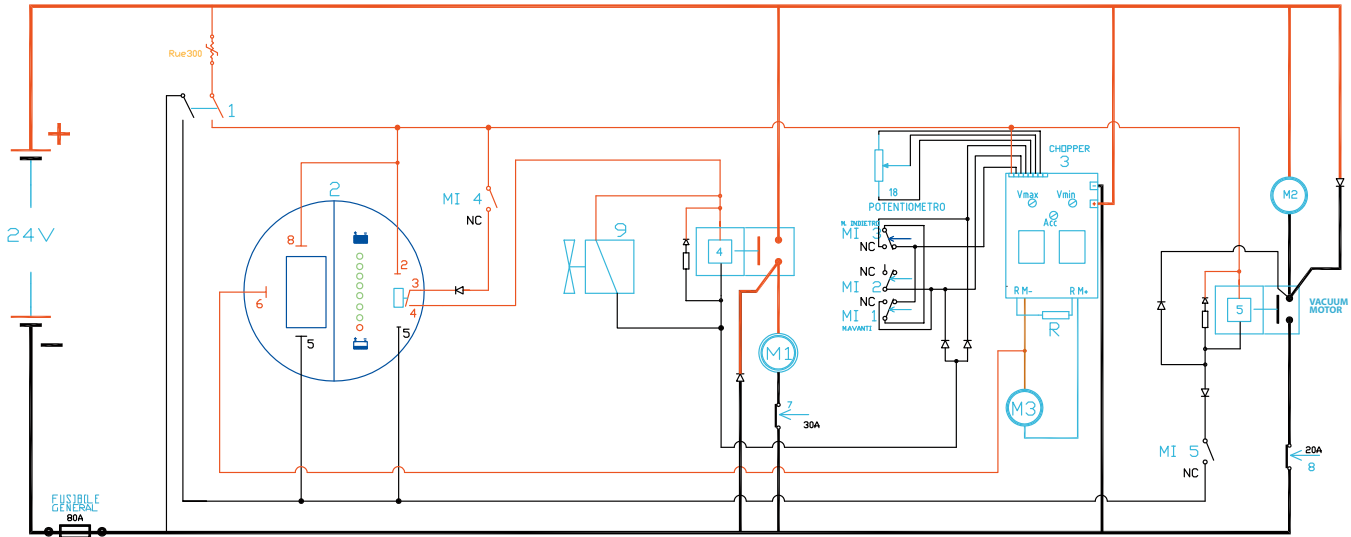

## ELECTRIC HARNESS INSPECTION

1. Verify the functionality of the variable speed control card.
2. If necessary adjust the variable speed control card as follows:
  - Lift up at least one of the traction wheels.
  - Remove the handlebar to gain access to the electric controls.
  - Place voltage meter probes on the faston **M+** and **M-** of the variable speed control card.
  - Turn on the key master switch.
  - Pull the lever until you hear the forward first **micro switch click** (first speed).
  - The tester has to show a voltage between 14 and 15 V. If the reading is different adjust the **trimmer "MA Lenta"** (first speed).
  - Completely pull the switch lever until the second (maximum) speed **micro switch** is pressed. A voltage of 24 V (the same as the battery voltage) should be observed.
  - Acceleration adjustment: Adjust the **"ACC" trimmer** to let it be between 30° and 45° respect the central position rotating clockwise. Verify that with this adjustment the machine reaches maximum speed in 4 seconds.
  - Check the backwards direction.
  - Check the braking power of the traction motor. At maximum speed the machine should stop in about 3 feet.

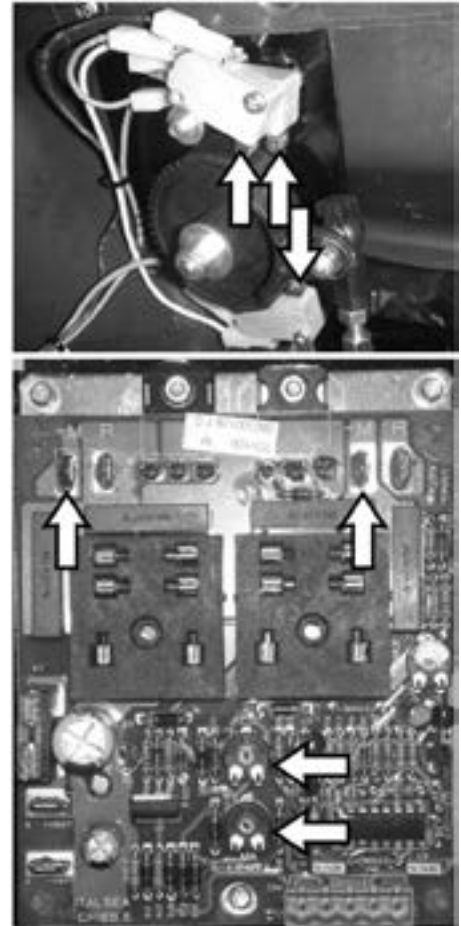

## BATTERY CHECK CARD – HOUR METER

1. Verify that when turning on the machine the battery check card has the following starting sequence:
  - Turning on of the LED which correspond to the set-up (red LED = “0”).
  - Turning on of all the LEDs (check of the lamps)
  - Turning on of the LEDs depending on the charge of the battery
2. Verify the hour meter functionality
  - To verify which is the set-up you turn on the machine and check which is the first LED that turns on. Counting the LEDs since the left side any LED correspond to a position and the LED which turn on correspond to the current set-up.



- Verify that if the machine uses wet cell batteries the adjustment is on position 1.



- Verify that if the machine uses GEL batteries the adjustment is on position 4.



**WARNING: A wrong set-up of the battery control card can compromise the battery efficiency and damage then in irreversible way.**

## WATER PLANT INSPECTIONS

1. Verify the cleanness and functionality of the **solution filter** under the solution tank plug.



2. Check cleanness and sealing of the **solution filter**.



3. Confirm that solution tank is completely filled.
4. Verify the sealing of the hoses, **solenoid valve** and the **water valve**.
5. Verify that the solution, with valve completely open, falls continuously on the floor.

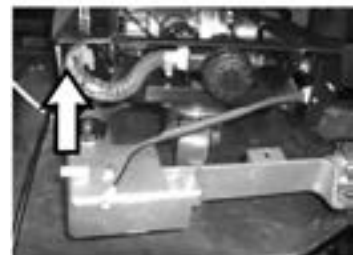

## BRAKE ADJUSTMENT

1. Adjust the brake pads on the wheels to lock the wheels when the brake lever reaches the third ratchet notch.
2. To adjust the pads:
  - Unscrew the **M8 jam nut**.
  - Adjust the **pad**.
  - Tighten the **M8 jam nut**.

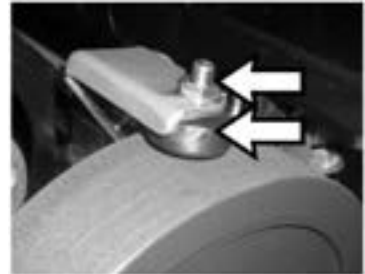
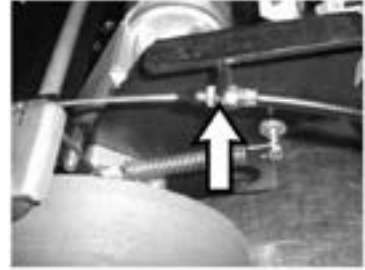

---

## VACUUM SYSTEM INSPECTION

1. Confirm that the **float filter** is clean.
2. Check the air sealing of the **vacuum unit** on the recovery tank.
3. Verify the connections and the sealing of the vacuum hoses and the squeegee hoses.
4. Check the sealing of the **squeegee hose adapter**.
6. Vacuum micro switch adjustment:
7. Adjust the vacuum micro switch in a manner that when the cam on the squeegee lift lever **pushes on the micro switch** there is 0.5 mm of clearance between the micro switch roller and the cam.

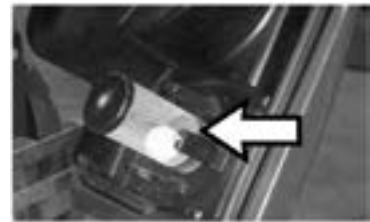

# SQUEEGEE ADJUSTMENT

1. Adjust the **inclination adjuster** of the squeegee assembly until the squeegee blade has a uniform deflection along its entire length.
2. Adjust the height of the squeegee wheels using the **knob** such that the squeegee blade has an inclination between 30 and 45 degrees.

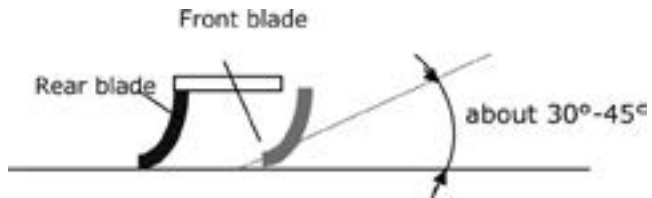

3. Verify that the squeegee assembly in up position does not interfere with the brush deck foot lever by adjusting the nyloc nut internal to the squeegee cable spring.

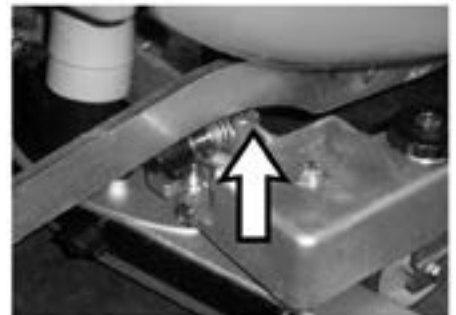
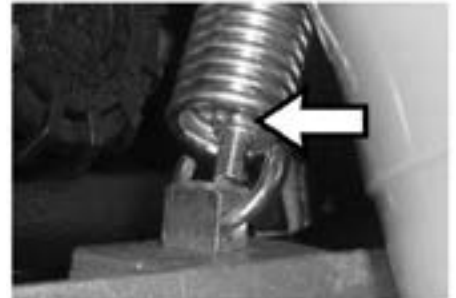
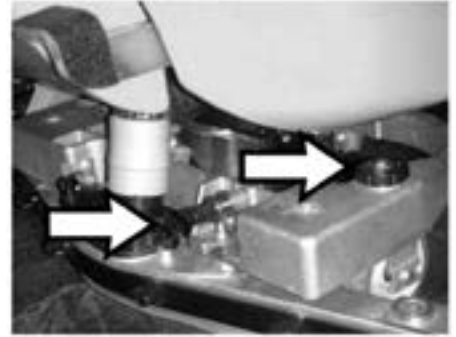

4. Adjust the spring tension so that the squeegee blades deflect when they contact the floor by tightening the nyloc nut.

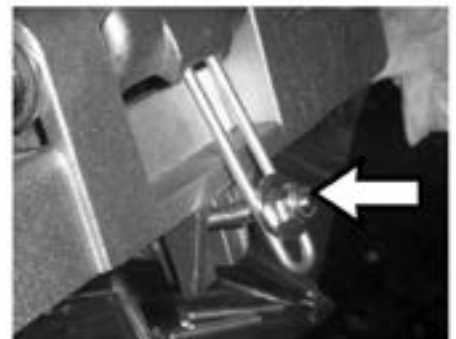

# CHECK LIST

## Functional check of the machine

- Check the functionality of switches and warning lamps.
- Check the functionality of the switch lever.
- Check the functionality of the brush deck.
- Check the functionality of the brush motor.
- Check the functionality of the solenoid valve.
- Check the functionality of the vacuum motor.
- Check the functionality of the brakes.
- Check the functionality of batteries and power cables.

## Functional test of the machine

- Fill the tanks completely and verify that there are no leaks.
- Adjust the inclination and the height of the squeegee blades.
- Adjust the inclination of the brush deck.
- Check the function of the parking brake.
- Verify the forward and backward movement, acceleration and braking.

## Final test

- Check all the functions: washing, drying and movement.

# MAINTENANCE SCHEDULE

<b>Stealth™ ASC20BT</b>		<b>RECOMMENDED SERVICE INTERVALS (HOURS)</b>						
<b>Machine components</b>	<b>Suggested replacement</b>	<b>DAILY</b>	<b>50</b>	<b>100</b>	<b>250</b>	<b>400</b>	<b>750</b>	<b>1,000</b>
<b>BATTERIES</b>	Check water level and add if necessary	DAILY						<del>1,000</del>
	Check cables, connections and plugs		50					<del>1,000</del>
	Check cleanliness of machine battery tray				250			
<b>ELECTRIC</b>	Check state of power contactors and fuses			100				<del>1,000</del>
	Check state of electric cables crossing the machine					400		
<b>SOLUTION TANK</b>	Check cleanliness of solution filter	DAILY					<del>750</del>	
	Check solenoid valve, hoses and connections to the brush head			100		<del>400</del>		
	Check flow of water on the brushes				250			
<b>RECOVERY TANK</b>	Check the cleanliness of the tank	DAILY						
	Check filter and float system	DAILY						<del>1,000</del>
	Check vacuum and drain hoses	DAILY						<del>1,000</del>
	Check vacuum gasket and drain hoses plugs		50					<del>1,000</del>
<b>BRUSH DECK</b>	Check tension and wear of belt and state of the bearings				250			<del>1,000</del>
	Check the right brush inclination			100				
	Check brush attachments (rust, ruined parts, cracks)				250			
	Check wear of spraying guard		50			<del>400</del>		
	Check wear of brushes		50	<del>100</del>				
	Check function of the lifting/lowering element				250			
<b>BRUSH MOTOR</b>	Check cleanliness of air cooling inlet			100				
	Check wear of carbon brushes				250	<del>400</del>		
	Check amps consumption and noise level						750	
<b>VACUUM MOTOR</b>	Check noise level and cleanliness of the inlet hose			100				
	Check wear of carbon brushes				250		<del>750</del>	
	Check the vacuum performance, replace if necessary							<del>1,000</del>
<b>SQUEEGEE</b>	Check cleanliness of the squeegee blades and the squeegee adjustment	DAILY						
	Check wear of central squeegee blades		50	<del>100</del>				
	Check wear of front squeegee		50		<del>250</del>			
	Check squeegee yoke					400		
<b>TRACTION SYSTEM</b>	Check wear of motor carbon brushes				250		<del>750</del>	
	Check cleanliness air cooling inlet			100				
	Check wear of wheels					400		
	Check state of bearings					400		
	Check the function of the parking braking				250			
	Check wear of brake pads					400		<del>1,000</del>

Suggested replacement

## WEAR ITEMS

### Stealth™ ASC20BT

PART NUMBER	DESCRIPTION
E82410	Brush, Front Cylindrical, White, 0.5mm PPL
E82528	Brush, Rear Cylindrical, Blue, 0.3mm PPL
E22162	Brush, Medium Duty, 0.6mm
E82331	Splash Guard, Right
E82431	Splash Guard, Left
E22637	Squeegee Blade Kit, 29"
E83979	Brush Drive Belt
E20700	Battery 12V 155 AH Wet
E88030	Battery 12V 110AH AGM
E88856	Battery 12V 135AH AGM
E88128	Charger 24VDC 12AMP 120VAC EXT AGM WET RSB50



# BETCO US WARRANTY POLICY

## 10 year coverage

Subject to the conditions stated below, Betco warrants parts and labor on rotationally molded polyethylene tanks/ housings and injection molded vacuum head assemblies to be free from defects in materials and workmanship for a period of ten years to the original purchaser.

## 3 Year Coverage

Subject to the conditions stated below, Betco warrants parts and labor on all other Betco components to be free from defects in materials and workmanship for a period of three years to the original purchaser.

## 1 Year Coverage

Subject to the conditions stated below, Betco offers a limited warranty on parts and labor on the following equipment: parts and accessories to be free from defects in materials and workmanship for a period of one year to the original purchaser.

- PowerUp™ 14 Upright Vacuum: #E29990-00
- Bac Pac Lite Vacuum: #85903-00
- FiberPRO® Floor Dryer: #85507-00
- WORKMAN™ Series Vacuums: #85024-00, #85025-00, #83012-00, #85027-00
- All Tools and Accessories
- All Battery Chargers
- All Batteries are pro-rated for 1 year

### **Allowable Travel Time Warranty Reimbursement:**

Eligible equipment: All battery and propane powered equipment products. Warranty period: 90 days from date of sale to the original purchaser. A maximum 180 mile round trip at 50 cents per mile will be allowed for warranty consideration.

### **Propane Machine Warranty:**

Kawasaki engines are warranted by Kawasaki for a period of 2 years against manufacturer defects. All other components (except wear items)\* are warranted by Betco for a period of 3 years.

**\*Wear Items exempt from Warranty consideration include but may not be limited to: power cords, transport wheels, vacuum bags, belts, squeegee blades, pad drivers, clutch plates, handle grips, filters, screens, throttle cables, brushes and carbon brushes.**

Subject to the conditions and exceptions stated in this warranty, Betco warrants the Betco products to be free from defects in material and workmanship, under normal use and service, for the periods listed under the warranty policy to the original purchaser. At any time during the warranty period, Betco will furnish replacement parts for the Betco parts to the original purchaser. Such parts will be furnished and charged including transportation costs, to the original owner through any Betco authorized Service Distributor. If the original part is returned within the warranty policy period from date of delivery for inspection by Betco and is found to be defective the owner will be credited for the cost of replacement parts plus shipping and handling. Replacement parts that have become defective through wear or abuse are not included in this warranty.

This warranty does not apply to damage or defect caused by accident, misuse, negligence, fire, or to any Betco product which has been serviced or repaired by other than an authorized Betco Service Distributor or Betco factory personnel. This warranty is void if products are used for any purpose other than that which was intended. There are no other warranties expressed or implied. In no event shall Betco be liable for incidental or consequential damages or any damage to person or property. (Please note some states do not allow the exclusion or limitations for incidental and consequential damages).

