



Electronic Service Manuals

This electronic document is provided as a service to our customers. We do not create the contents of the information contained in this document. Should you have detailed questions pertaining to the information contained in this document, you may contact Michco, or the manufacturer which provided the original information in this electronic deliverable. Michco's only part in this electronic deliverable was the electronic assembly process. By providing this manual on line we are not guaranteeing parts availability.

You may contact Michco through the following methods:

Phone (517) 484-9312 or (800) 331-3339

2011 N. High St. -- Lansing, Michigan -- 48906

Fax: (517) 484-9836

Email: CustServe@Michco.com

Web site: www.Michco.Com

Parts Web site: www.FloorMachineParts.Com

Order Parts on Line at:

www.FloorMachineParts.Com

Directly to Parts & Service:

By Email: **Shop@Michco.com**

By Fax: (517) 702-2041

By Voice: Use numbers above.

Serving the Cleaning Industry Since 1922

Notice: All copyrighted material remains property of original owners, all trademarks are property of respective owners. Manuals are subject to Manufacturer's reproduction limitations. Originals or reproductions were provided by manufacturers through a request. We make no warranty as to the correctness of information provided in this document and you assume all risk. By placing these manuals on line we are not declaring our corporation to be an manufacturer authorized dealer or provider, please check our web site for authorized manufacturers we represent.

American-Lincoln®

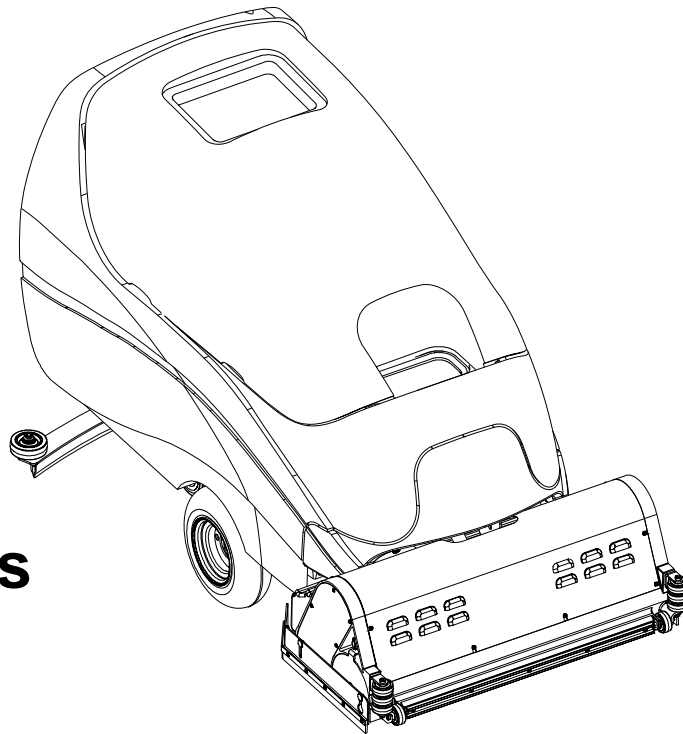

**Operator's
Manual**

**ENCORE
33HD
Cylindrical**

READ THIS BOOK

This book has important information for the use and safe operation of this machine. Failure to read this book prior to operating or attempting any service or maintenance procedure to your American Lincoln machine could result in injury to you or to other personnel; damage to the machine or to other property could occur as well. You must have training in the operation of this machine before using it. If your operator(s) cannot read English, have this manual explained fully before attempting to operate this machine.

Si Ud. o sus operadores no pueden leer el Inglés, se hagan explicar este manual completamente antes de tratar el manejo o servicio de esta máquina.

All directions given in this book are as seen from the operator's position at the rear of the machine.

For new books write to: **American-Lincoln®**, 2100 Highway 265, Springdale, Arkansas 72764.

Table of Contents

Operator Safety Instructions	3
Introduction & Machine Specifications	5
Procedures For Transporting	6
Symbols Used On Encore Machines	7
Machine Control Panel	8
Machine Controls and Features	9
How To Prepare The Machine For Operation	10
How To Install The Batteries	10
Battery Maintenance	11
How To Charge The Batteries	12
How To Change or Rotate Brushes	13
How To Operate The Machine	14
How To Operate The Squeegee	14
How To Fill The Solution Tank	14
How To Clean A Floor	16
Maintenance	17
Accessories	22

Section II Parts and Service Manual

How To Correct Problems In The Machine	24
Maintenance, Head Position System	25
Swing Arm Assembly Drawing	26
Parts List	27
Squeegee Assembly Cylindrical	28
Parts List	29
Traverse System Assembly Drawing	30
Parts List	31
Brush Head Assembly Drawing	32
Parts List	33
Lift Actuator Assembly Drawing	34
Parts List	35
Solution/Recovery System Assembly Drawing	36
Parts List	37
Control Housing Assembly Drawing	38
Parts List	39
Rear Cover Assembly Drawing	40
Parts List	41
VacMotor	42
Imperial Transaxle Drawing and Parts List	43
36 Volt Battery Charger (40506A, 40507A, 40505A, 40514A & 40515A) Drawing & Parts List	44
Battery Charger (40512B / 40506B) Drawing & Parts List	45
Electrical Schematic	45
Connection Diagram	46

OPERATOR SAFETY INSTRUCTIONS



WARNING



AVERTISSEMENT



ADVERTENCIA



DANGER: Failure to read and observe all **DANGER** statements could result in severe bodily injury or death. Read and observe all **DANGER** statements found in your Owner's Manual and on your machine.



WARNING: Failure to read and observe all **WARNING** statements could result in injury to you or to other personnel; property damage could occur as well. Read and observe all **WARNING** statements found in your Owner's Manual and on your machine.



CAUTION: Failure to read and observe all **CAUTION** statements could result in damage to the machine or to other property. Read and observe all **CAUTION** statements found in our Owner's Manual and on your machine.



DANGER: Failure to read the Owner's Manual prior to operating or attempting any service or maintenance procedure to your American Lincoln machine could result in injury to you or to other personnel; damage to the machine or to other property could occur as well. You must have training in the operation of this machine before using it. If your operator(s) cannot read English, have this manual explained fully before attempting to operate this machine.



DANGER: Operating a machine that is not completely or fully assembled could result in injury or property damage. Do not operate this machine until it is completely assembled. Inspect the machine carefully before operation.



DANGER: Machines can cause an explosion when operated near flammable materials and vapors. Do not use this machine with or near fuels, grain dust, solvents, thinners, or other flammable materials. This machine is not suitable for picking up hazardous dust.



DANGER: Lead acid batteries generate gases which can cause an explosion. Keep sparks and flames away from batteries. Do not smoke around the machine. Charge the batteries only in an area with good ventilation. Make sure that you unplug the AC charger from the wall outlet before disconnecting from the machine.



DANGER: Working with batteries can be dangerous! Always wear eye protection and protective clothing when working near batteries. Remove all jewelry. Do not put tools or other metal objects across the battery terminals, or the tops of the batteries.



DANGER: Using a charger with a damaged power cord could result in an electrocution. Do not use the charger if the power cord is damaged.











WARNING: Operating this machine from anywhere other than the back of the machine could result in injury or damage. Operate this machine only from the rear.



WARNING: This machine is heavy. Get assistance before attempting to transport or move it. Use two able persons to move the machine on a ramp or incline. Always move slowly. Do not turn the machine on a ramp. If operating machine on a gradient over 2%, do not stop, turn or park. Read the "Procedures For Transporting" in this manual before transporting.



WARNING: Machines can topple over if guided over the edges of stairs or loading docks and cause injury or damage. Stop and leave this machine only on a level surface. When you stop the machine, turn the key "OFF". Set the parking brake.

-  **WARNING:** Maintenance and repairs performed by unauthorized personnel could result in damage or injury. Maintenance and repairs must be performed by authorized American Lincoln personnel only.
-  **WARNING:** Any alterations or modifications of this machine could result in damage to the machine or injury to the operator or other bystanders. Alterations or modifications not authorized by the manufacturer voids any and all warranties and liabilities.
-  **WARNING:** Electrical components of this machine can "short-out" if exposed to water or moisture. Keep the electrical components of the machine dry. Wipe the machine down after each use. For storage, keep the machine in a dry building.
-  **WARNING:** Operating a machine without observing all labels and instructional information could result in injury or damage. Read all machine labels before attempting to operate. Make sure all of the labels and instructional information are attached or fastened to the machine. Get replacement labels and plates from your American Lincoln distributor.
-  **WARNING:** Wet floor surfaces can be slippery. Water solutions or cleaning materials used with this type of machine can leave wet areas on the floor surface. These areas can cause a dangerous condition for the operator or other persons. Always put "Caution" signs around/near the area you are cleaning.
-  **WARNING:** Improper discharge of waste water may damage the environment and be illegal. The United States Environmental Protection Agency has established certain regulations regarding discharge of waste water. Also, city and state regulations regarding this discharge may be in your area. Understand and follow the regulations in your area. Be aware of the environmental hazards of chemicals that you dispose.
-  **CAUTION:** Use of this machine to move other objects or to climb on could result in injury or damage. Do not use this machine as a step or furniture. Do not ride on this machine.
-  **CAUTION:** Your machine warranty will be voided if anything other than genuine American Lincoln parts are used on your machine. Always use American Lincoln parts for replacement.

Introduction & Machine Specifications

Introduction & Machine Specifications

American Lincoln's newly designed Encore 33HD Cylindrical automatic scrubber is an efficient and superior floor cleaning machine. The Encore 33HD Cylindrical uses two brushes to scrub a path 33 inches wide. A squeegee wipes the floor while the vacuum motor removes the dirty solution from the floor - all in one pass.

The Encore 33HD Cylindrical comes complete with six - 6 volt batteries, five battery connector cables, one battery cable assembly, one battery charger, two brushes, and one operator's manual.

SPECIFICATIONS:

Model	33HD Cylindrical
Motor, Vac Power Supply Solution Tank	1 HP (.67kw) three stage tangential discharge 36 volt (6-6V batteries) 250AH, 330AH, or 370AH 30 gallon (114 liter)
Recovery Tank	30 gallon (114 liter)
Motors, Brush (2)	.75 hp PM (.56kw)
Motor Traction	.50 hp PM (.37kw)
Brushes (2)	31" Cylindrical
Brush Speed	750 rpm
Brush Pressure	100 lbs.
Speed, Forward	Variable to 230 ft./min.
Speed, Reverse	Variable to 180 ft./min.
Charger	36V, 25A, 115V/60hz
Length	66 inches (168cm)
Width - Machine	28 inches (71cm)
Height	44 inches (112cm)
Cleaning Rate	42,000 sq ft/hr (3,901 sq. m/hr)
Cleaning Swath	33 inch (83.8 cm)
Grade Cleaning	6° Incline
Weight w/Batteries (330AH)	1038 lbs. 471kg
Shipping Weight w/batteries (330AH)	1341 lbs. 608kg

PROCEDURES FOR TRANSPORTING

How To Put The Machine In A Van Or Truck

 **WARNING:** The machine is heavy. Make sure you use two able persons to assist the machine in climbing the ramp.

1. Make sure the loading ramp is at least eight (8) feet long, and strong enough to support the machine.
2. Make sure the ramp is clean and dry.
3. Put the ramp in position.
4. Remove squeegee assembly, brush housings, & brushes or pad drivers before loading.
5. Turn key switch "ON".
6. Align the machine on a level surface ten (10) feet in front of the ramp.
7. Put the traverse speed switch in the "HI" position.
8. Push the control handles toward the machine all the way.
9. Push the machine to the top of the ramp.
10. Turn the key switch "OFF".
11. Fasten the machine to the vehicle.

How To Remove The Machine From A Van Or Truck

1. Make sure there are no obstructions in the area.
2. Make sure the unloading ramp is at least eight (8) feet long and strong enough to support the machine.
3. Make sure the ramp is clean and dry.
4. Put the ramp in position.
5. Unfasten the machine.

 **WARNING:** The machine is heavy. Make sure you use two able persons to assist in moving the machine down the ramp.

6. Turn the key switch "ON".
7. Carefully and slowly, pull the machine to the top of the ramp.
8. Put the traverse speed switch in the "HI" position.
9. As the machine begins to travel down the ramp, push the control handles toward the machine to maintain a slow downward speed.
10. Replace squeegee assembly, brush housings, & brushes or pad drivers after the machine is unloaded and ready to use.

SYMBOLS USED ON ENCORE 33HD Cylindrical



Warning



Battery Meter



Power

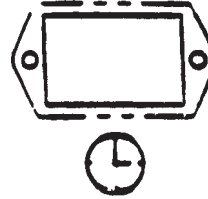

Hour Meter

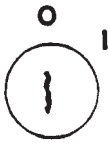

On/Off Key Switch

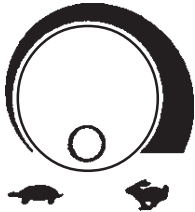

Traverse Speed Control



Warning Label



Solution Control



Brush Up/Down

MACHINE CONTROL PANEL

Key Switch (See Figure #1, Item "A")

The key switch turns "ON" the power to the control panel. "0" is "OFF" and "1" is "on".

Traverse Speed Switch (See Figure #1, Item "B")

The speed control varies from low to high speed. To increase the speed, turn the knob to the right. To decrease the speed, turn the knob to the left.

Brush Up/Down Switch (See Figure #1, Item "C")

The brush switch has two positions: "Up" positions the brushes up; "Down" positions the brushes on the floor. The brush motors start when the brushes are down.

Solution Control Knob (See Figure #1, Item "D")

The solution control knob regulates the flow of cleaning solution to the floor. To increase the flow turn the knob clockwise. To decrease the flow, turn the knob counter-clockwise.

Control Handle (See Figure #1, Item "E")

The control handle is located at the rear of the machine. It controls the direction of the machine. Push forward to go forward. (See Figure #3, page 10). Pull back to move in reverse. (See Figure #4, page 10).

Circuit Breakers (See Figure #1, Item "F"- "J")

The circuit breaker reset buttons are located on the rear cover, below the control handle. The breakers are located as follows: Item F & G - Brush Motors (35A)

Item H - Traverse Motor (30A)

Item I - Vac Motor (25A)

Item J - Actuator Motor, Brush Head (5A)

If a circuit breaker trips, determine which motor is not operating and turn the key switch "OFF". Wait five minutes and push the reset button back in. Turn the key switch "ON", and try again. An authorized service person should be contacted if the breaker trips again.

Hour Meter (See Figure #1, Item K)

The hour meter indicates the number of hours the machine has operated. It runs only when the machine is moving forward or reverse.

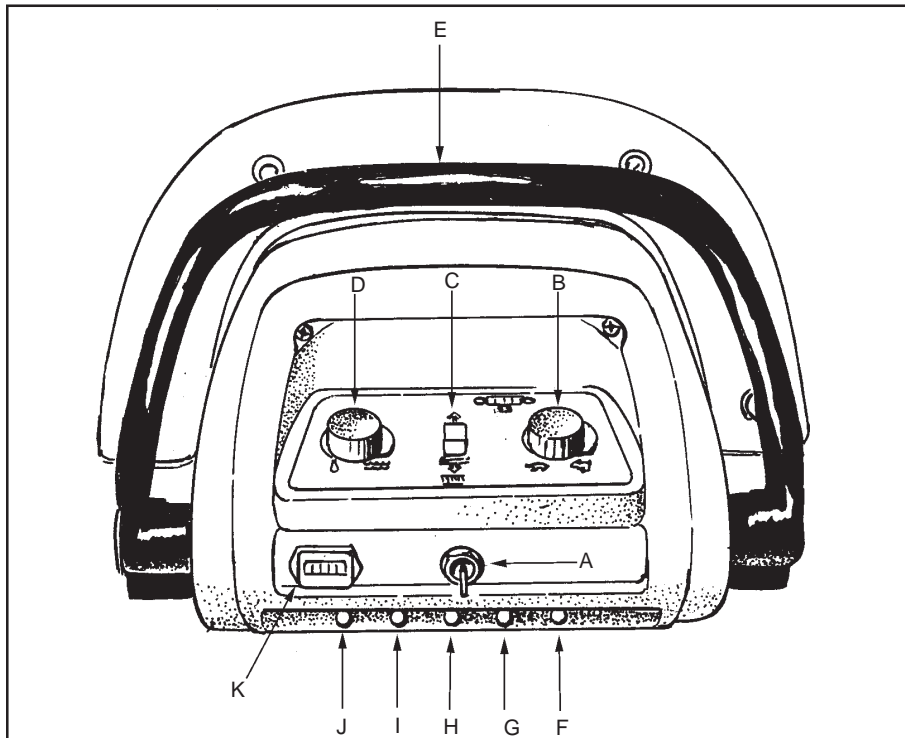

Figure #1

MACHINE CONTROLS & FEATURES

Squeegee Lift Handle See Figure #5a, 5b, & 5c.
The squeegee lift handle is located below the control handles on the right side. It is used to raise or lower the squeegee. The vac motor is turned on when the handle is lowered. (S38, S33 & S28 models only).

Parking Brake (Optional) See Figure #6.
The parking brake prevents movement of the machine. The brake is located on the left hand side of the transaxle motor. Turn the key switch off or disconnect the power to the battery to apply the brake.

There is a mechanical lever located on the brake. This lever is an override. To manually release the brake, rotate the lever toward the rear of machine (counter clockwise). To return the brake to normal or to apply the brake, rotate the lever towards the front of the machine (clockwise). **NOTE: If the lever is left in the override position, the brake will not function with the key switch, and the machine will not operate.**

CAUTION: Do not activate the brake while the machine is moving.

Float Shut Off See Figure #7.
The shut-off switch for the vac motor is located in the recovery tank. It automatically turns off the vac motor when the recovery tank is full.

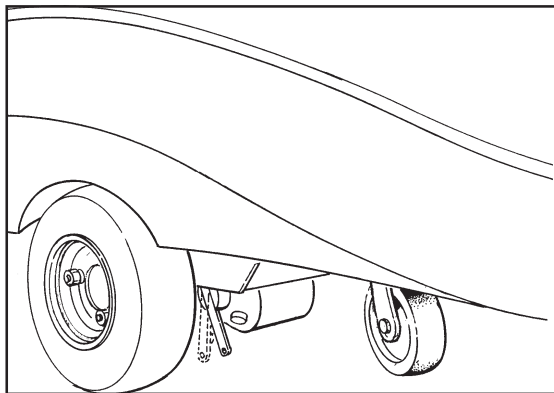

Figure #6

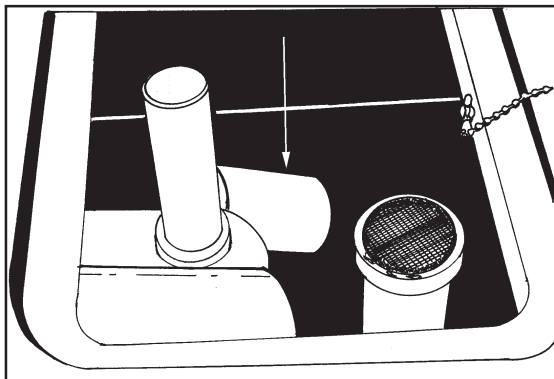

Figure #7

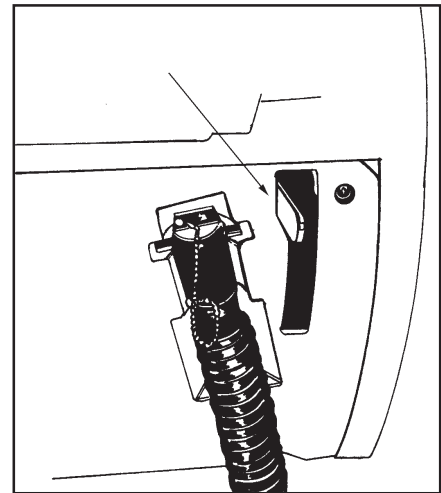

Figure #5a

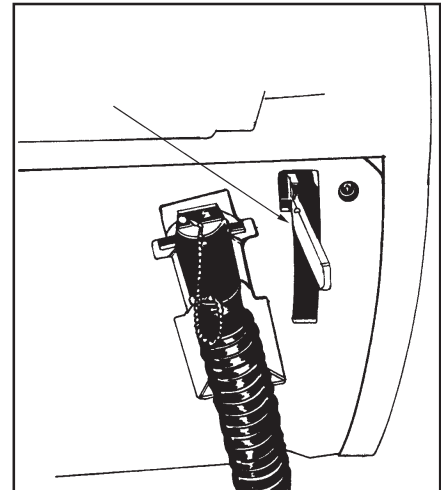

Figure #5b

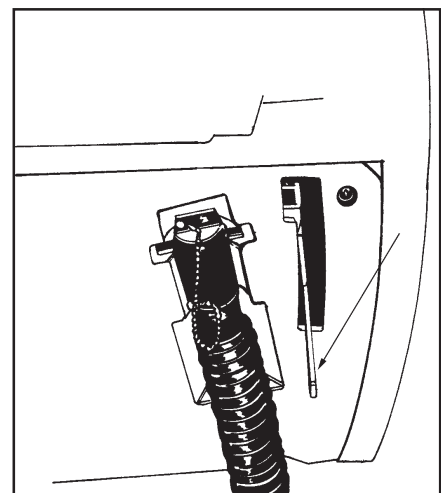

Figure #5c

HOW TO PREPARE THE MACHINE FOR OPERATION

How To Install The Batteries

The 38, 33 and 28 Encore machines use six 6-volt or three 12-volt batteries. The batteries are located in the battery compartment under the recovery tank.

To Install the batteries, follow this procedure:

1. Turn key switch off.
2. Make sure both tanks are empty.
3. Disconnect the hoses from the recovery tank (upper tank) & unplug the vac motor. Remove the recovery tank.
4. Place the batteries in the solution tank as shown in figures 8a - 8d.

WARNING: Lifting batteries without help could result in an injury. Get help to lift the batteries. The batteries are heavy.

WARNING: Working with batteries can be dangerous. Always wear eye protection and protective clothing when working near batteries. **NO SMOKING!**

5. Connect the battery cables between batteries and install long battery cable assembly as indicated. See figure 8a - 8d.

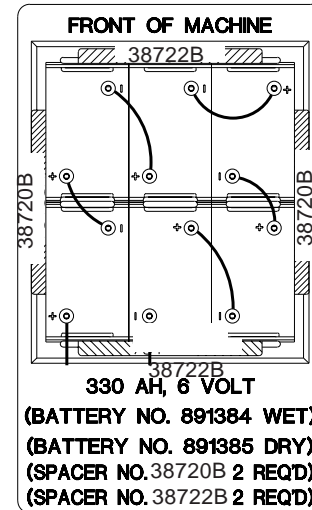

Figure #8a

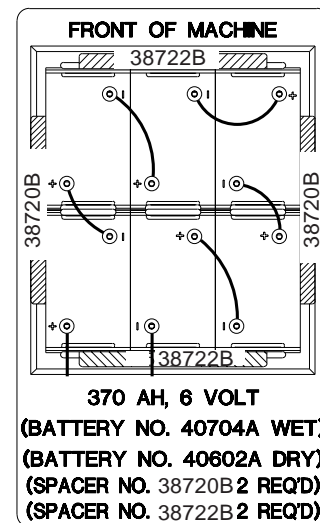

Figure #8b

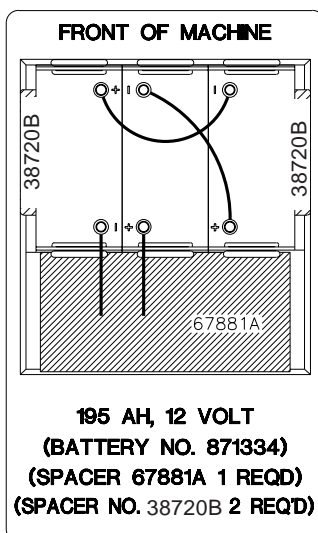

Figure #8c

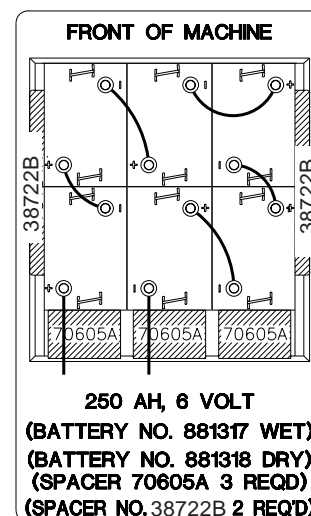

Figure #8c

HOW TO PREPARE THE MACHINE FOR OPERATION

6. Join the connector from the battery pack to the connector on the control panel. See figure #9.
7. Install the tank, reconnecting hoses and replace the two screws attaching the solution tank to the rear of the frame.

NOTE: Charge the batteries before using the machine.

Battery Maintenance

The electrical power to operate the machine comes from the storage batteries. Storage batteries need preventive maintenance.

⚠ WARNING: Working with batteries can be dangerous. Always wear eye protection and protective clothing when working near batteries. **NO SMOKING!**

To maintain the batteries in good condition, follow these instructions:

1. Keep the electrolyte at the correct level. The correct level is between 1/4" below the bottom of the tube in each cell and above the tops of the plates. Check the level of the electrolyte each time you charge the batteries. See figure #10.

NOTE: Check the level of electrolyte prior to charging the batteries. Be sure the plates in each cell are covered with electrolyte. Do not top off the cells prior to charging the battery. Electrolyte expands during charging. As a result, the electrolyte could overflow from the cells. Always top off the cells with distilled water after charging.

⚠ CAUTION: Irreversible damage will occur to the batteries if the electrolyte level does not cover the plates. Keep the electrolyte at the correct level.

⚠ CAUTION: Machine damage and discharge across the tops of the batteries can occur if the batteries are filled above the bottom of the tube in each cell. Do not fill the batteries up to the bottom of the tube in each cell. Wipe any acid from the machine or the tops of the batteries. Never add acid to a battery after installation.

⚠ CAUTION: Tap water may contain contaminants that will damage batteries. Batteries must be re-filled with distilled water only.

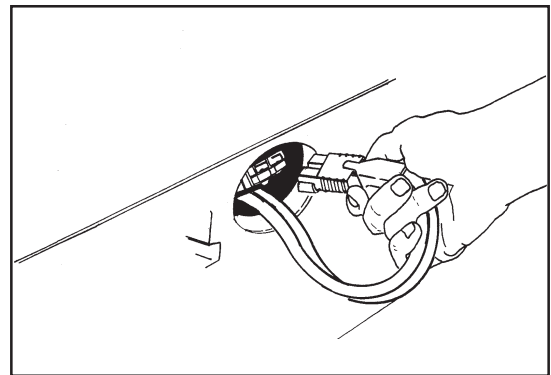

Figure #9

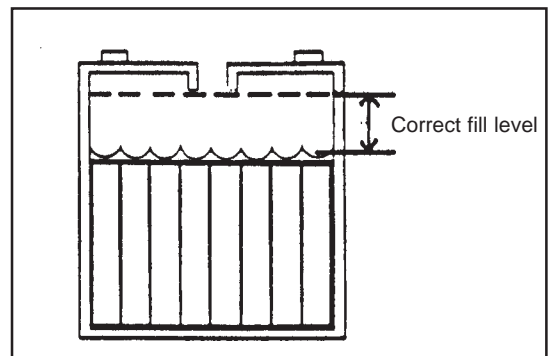

Figure #10

2. Keep the tops of the batteries clean and dry. Keep the terminals and connectors clean. To clean the top of the batteries, use a damp cloth with a weak solution of ammonia or bicarbonate of soda solution. To clean the terminals and connectors, use a terminal and connector cleaning tool. Do not allow ammonia or bicarbonate of soda to get into batteries.
3. Keep the batteries charged.

HOW TO PREPARE THE MACHINE FOR OPERATION

How To Charge The Batteries

- ⚠ WARNING:** Charging the batteries in an area without adequate ventilation could result in an explosion. To prevent an explosion, charge the batteries only in an area with good ventilation.
- ⚠ WARNING:** Lead acid batteries generate gases which could explode. Keep sparks and flames away from batteries. **NO SMOKING!**
- ⚠ WARNING:** Failure to disconnect the AC plug from the wall receptacle before connecting or disconnecting the DC connector on the charger could result in an explosion. Always disconnect the AC plug from the wall receptacle before connecting or disconnecting the DC connector on the charger.

To charge the batteries, follow this procedure:

1. Put the charger on a flat surface. Make sure the vents on the sides are at least two inches away from walls and other objects. Make sure there are no objects near the vents on the bottom of the charger.
2. Make sure the key switch is in the "OFF" position.
3. Disconnect the battery pack connector from the control housing connector. See figure #11.
4. Connect the DC connector on the charger to the battery pack connector. See figure #12.
5. Connect the charger to a properly grounded single phase (3-wire) wall receptacle having the voltage, frequency, and ampere capacity specified on the nameplate of the charger.

For more instruction on the use of the charger, read the instruction book supplied with the charger.

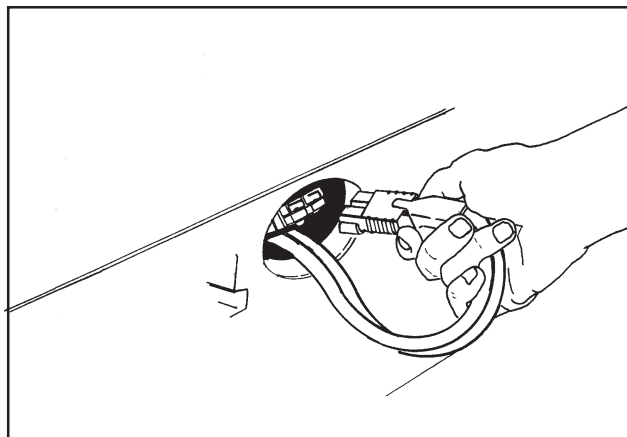

Figure #11

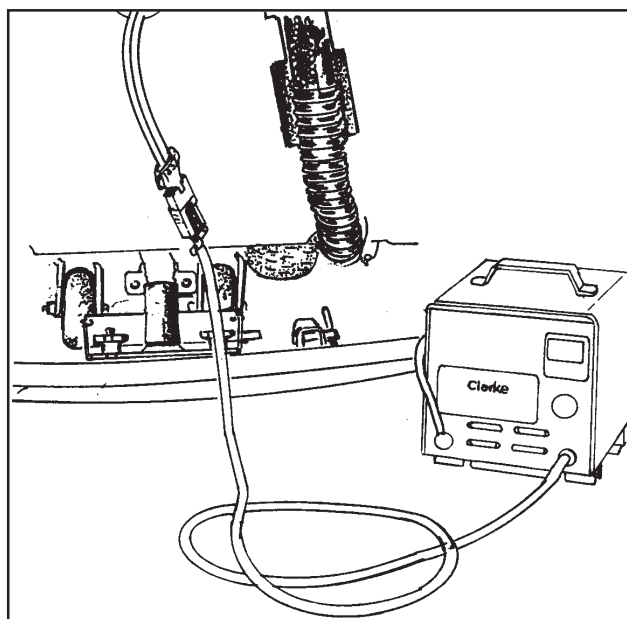

Figure #12

HOW TO PREPARE THE MACHINE FOR OPERATION

How To Change or Rotate Brushes

To install or rotate brushes on the machine, follow this procedure:

1. Turn the key switch "ON".
2. Put the brush switch in the "UP" position.
3. Turn the key switch "OFF".
4. Go to the front of the machine and remove thumb screw from brush door. See figure #13.
5. Lower door approximately 1/2 inch and slide door and hub assembly from brush. See figure #14.
6. Slide brush off hub at opposite end. See figure #15.
7. Rotate brush or replace.
8. Slide brush on drive hub and insert door and hub assembly into brush core.
9. Raise door and install thumb screw.
10. Repeat steps 4 through 9 to install the second brush.

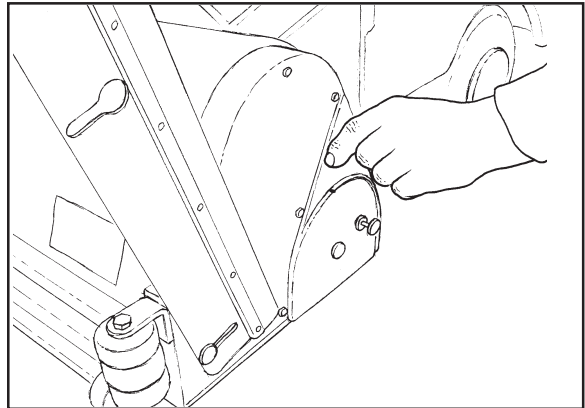

Figure # 13

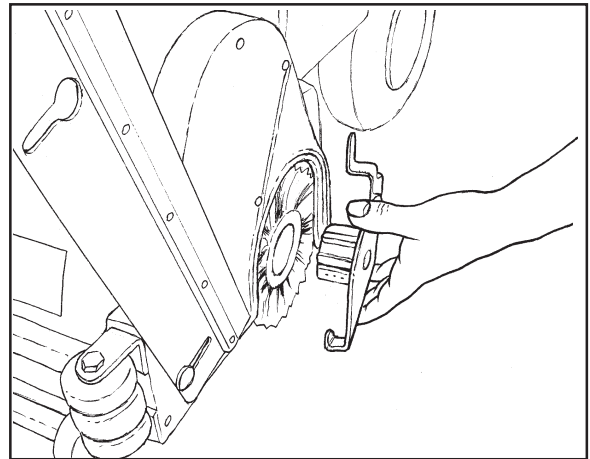

Figure # 14

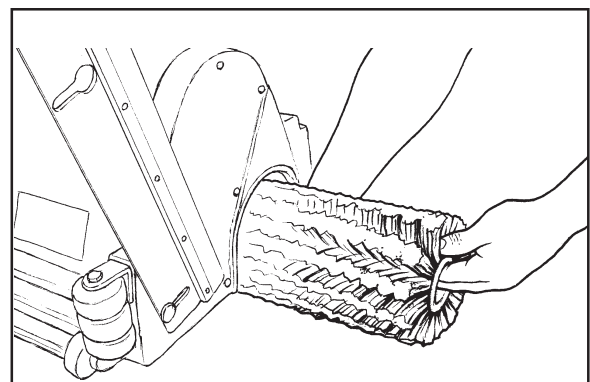

Figure # 15

HOW TO OPERATE THE MACHINE

How To Operate the Squeegee ("S Class" models only)

The squeegee wipes the floor while the vacuum motor removes the dirty solution from the floor. Use your right hand to lower or raise the squeegee handle. To operate the squeegee, follow this procedure:

1. To lower the squeegee and start the vac motor move the squeegee lever to the right and down. See figure #16.
2. To raise the squeegee, lift the squeegee lever up. See figure #17.

Note: The center position lets the vac motor continue to run with the squeegee off the floor to avoid drips.

How to Fill The Solution Tank

CAUTION: Make sure water or solution does not enter the opening for the vacuum motor. See figure #18.

The solution tank lid is at the front. To fill the solution tank follow this procedure:

1. Remove the solution tank lid. See figure #19.
2. Fill the solution tank with water.
3. Add a cleaning chemical to the water. for the correct amount, follow the directions shown on the container.

WARNING: Water solutions or cleaning materials used with this type of machine can leave wet areas on the floor surface. These areas can cause a dangerous condition for the operator or other persons. Always put CAUTION signs near the area you are cleaning.

WARNING: Machines can ignite flammable materials and vapors. Do not use with or near flammables such as gasoline, grain dust, solvents, and thinners. Only use a cleaning concentration recommended by the chemical manufacturer.

WARNING: American Lincoln recommends a maximum water temperature of 120°F(49°C)

4. Replace the solution tank lid.

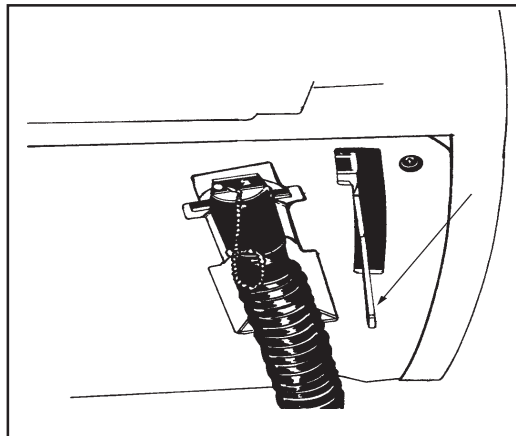

Figure #16

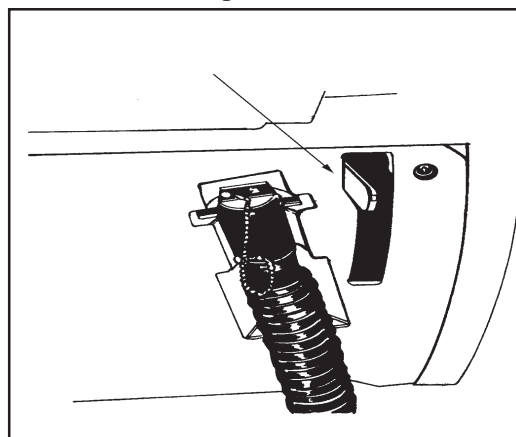

Figure #17

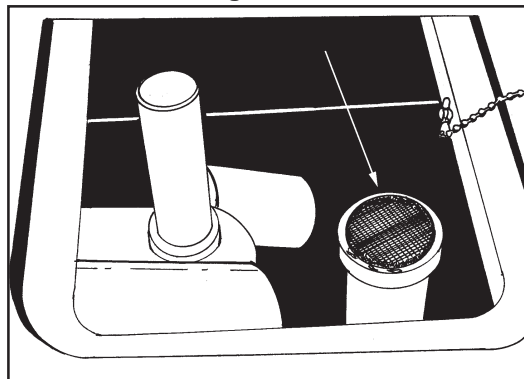

Figure #18

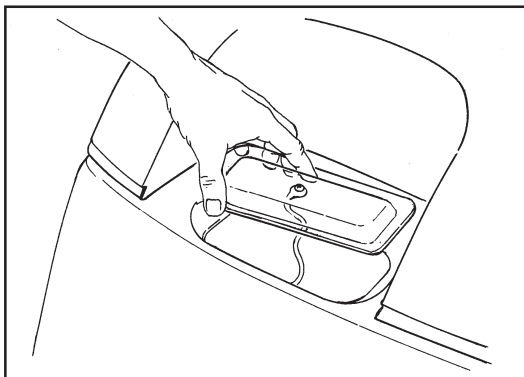

Figure #19

HOW TO OPERATE THE MACHINE (cont.)

NOTE: Put the machine in the slow traverse speed. Use the machine in an area that has no furniture and objects until you can do the following:

1. Move the machine in a straight direction, forward and backward.
2. Stop the machine safely.
3. Move the machine in a straight direction after you turn the machine.

To move the machine, follow this procedure:

1. Turn the key switch "ON" position.
2. Put the brush switch in the "UP" position.
3. Raise the squeegee.
4. To go forward, push the control handles toward the machine. See figure #20.
5. To stop the machine, put the handles in the center position.
6. To go backward, pull the handles away from the machine. See figure #21.
7. To turn the machine, push the rear of the machine to the side.
8. When you stop the machine, turn the key switch "OFF".

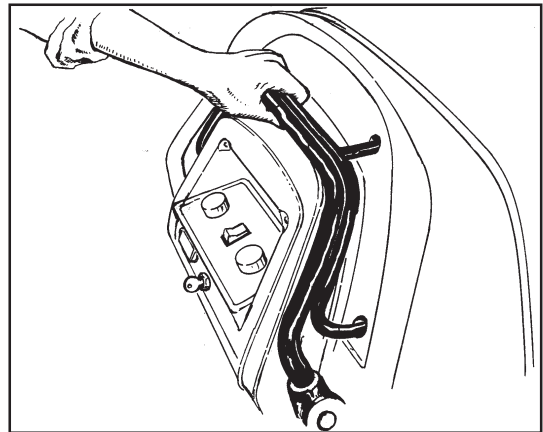

Figure # 20

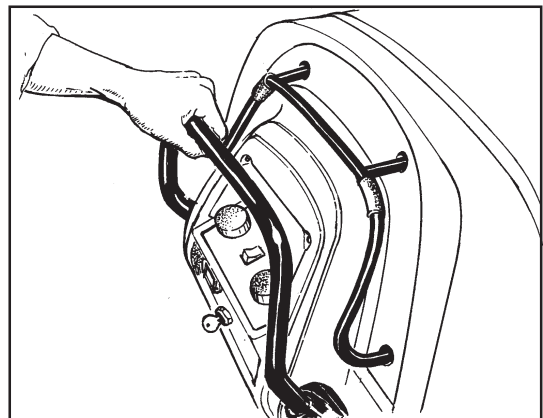

Figure #21

HOW TO OPERATE THE MACHINE (cont.)

HOW TO CLEAN A FLOOR

⚠ WARNING: Water solutions or cleaning materials used with this type of machine can leave wet areas on the floor surfaces. These areas can cause a dangerous condition for the operator or other persons. Always put CAUTION signs near the area you are cleaning.

To clean a floor, follow this procedure:

1. Put the water and a cleaning chemical in the clean solution tank.
2. Turn the key switch "ON".
3. Lower the squeegee.
4. Put the brush switch in the "DOWN" position.
5. Turn the solution knob to the right to activate the flow of solution. Adjust the flow of clean solution to the flow desired.
6. Move the machine across the floor in the forward direction. See figure #22 (1).
7. When the machine is one machine length from the end of the area to be cleaned (figure #22 (2)), rotate the solution knob to the left.
8. Make a 180° turn. See figure #22 (3).

NOTE: When you make more passes across the floor, let the brushes clean approximately 2 inches of the area already cleaned by the brushes. See figure #22 (4).

NOTE: During most cleaning procedures, apply and remove the solution in one operation.

HOW TO CLEAN A VERY DIRTY FLOOR

To clean a very dirty floor, follow this procedure:

1. Apply solution to the floor.
2. Do not lower the squeegee.
3. Do not activate the vacuum motor.
4. Lower the brushes and scrub the floor.
5. Leave the solution on the floor long enough for the solution to begin cleaning the floor.
6. Scrub the floor again with additional solution, picking up all the solution with the squeegee

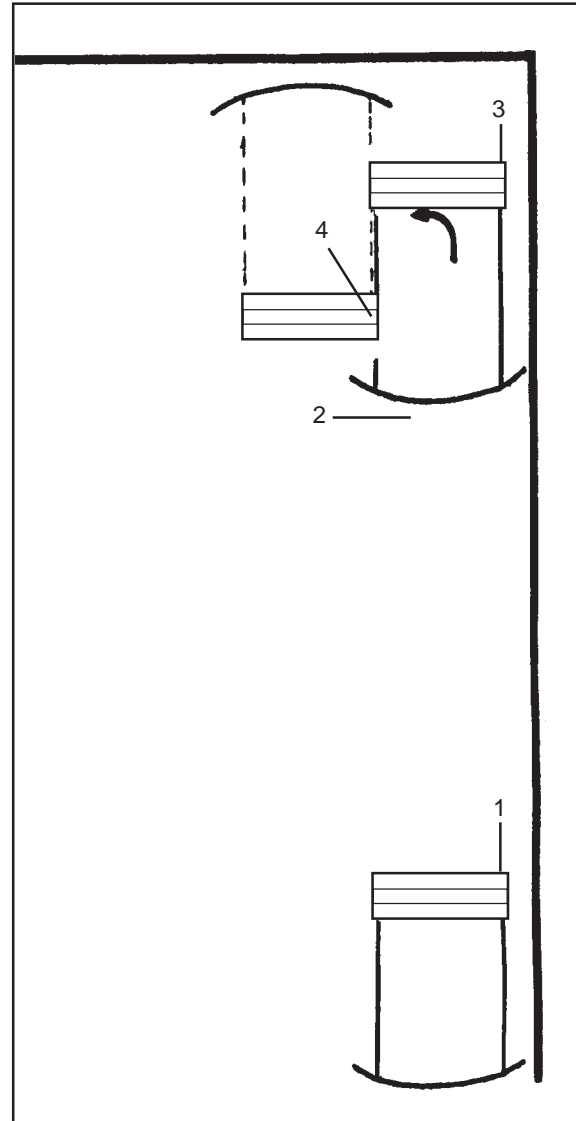

Figure #22

MAINTENANCE

⚠ WARNING: Maintenance and repairs must be done by authorized personnel only.

⚠ WARNING: Always empty the solution tank and recovery tank before doing any maintenance.

⚠ WARNING: Keep all fasteners tight.

These Maintenance Procedures Must Be Done Every Day

Keep the machine clean, it will need fewer repairs and have longer life.

Do These Procedures When You Begin Your Work Period

1. Turn off key switch.
2. Disconnect the plug on the charger from the connector on the back of the machine. See figure #23.
3. Join the connector from the batteries (1) to the control panel cable connection. See figure #23.
4. Make sure the recovery tank lid is on correctly. See figure #24, Item A.
5. Make sure the Screen filter over the vacuum motor is clean and in position. See figure #25, Item B.
6. Make sure the valves on the drain hoses are clean. Tightly close the valves.
7. Make sure brush housings and skirts are in position on the brush head.
8. Make sure the brushes are in position and installed correctly
9. Check the installation of the squeegee and squeegee hose.

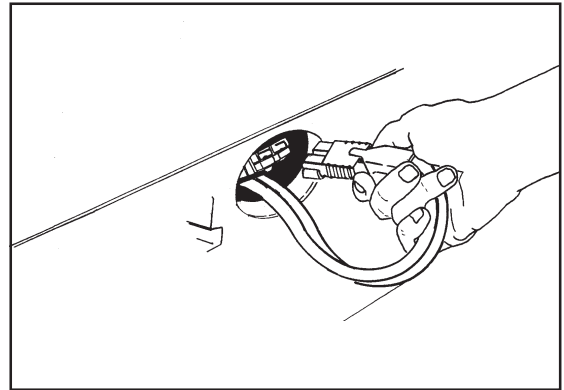

Figure #23

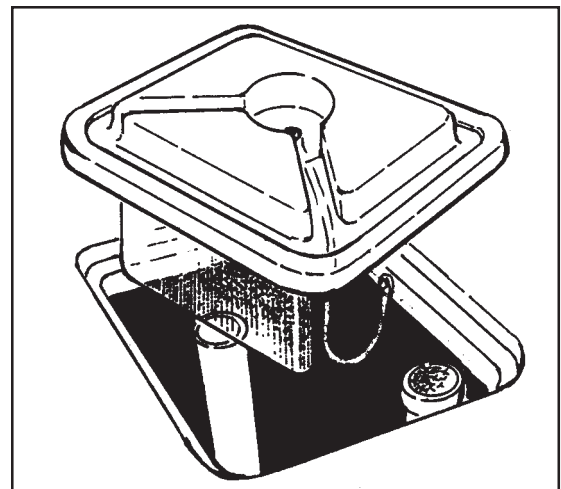

Figure #24

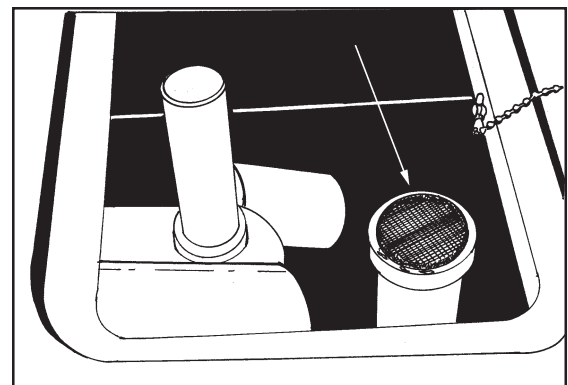

Figure #25

MAINTENANCE

Do These Procedures When You End Your Work

1. Drain the solution tank (Figure #26) and the recovery tank (Figure #27). To drain the tanks , follow this procedure:
2. Drain the solution tank (Figure #26) and the recovery tank (Figure #27). To drain the tanks , follow this procedure:
 - a. Turn the key switch "OFF".
 - b. Remove the drain hose from the back of the machine.
 - c. Put the end of the hose over a drain or bucket.
 - d. Turn the valve handle to the left. Pull the handle out to open the drain. (Figure #28)

NOTE: Have the opening in the side of the valve away from you when you open the valve.

- e. To open the valve completely, turn the handle to the right. Pull the handle out of valve. (Figure #29)
2. Flush the tanks. To flush the tanks, put clean water in the tank through the opening on top of the tank.
 3. If a tank or drain hose has an obstruction, use a high pressure water hose to flush the tank or hose. Put the water hose into the drain hose.
 4. Leave the tanks and the drain valves open to dry in the air.
 5. Check the squeegee blade. Use a cloth to clean the squeegee blade. If the squeegee blade is damaged or worn, turn or replace the blade.
 6. Check and clean the solution lid gasket. Use a mild cleaning solution and rinse the parts in clean water.
 7. The debris tray needs to be emptied regularly to prevent overflow. To remove the debris tray from the machine, follow this procedure (See Figure 30):
 - a. Raise brush head.
 - b. Go to the left side of the machine, to the rear of the cylindrical brush head.
 - c. Raise side skirt and swing out back side to disengage from spacer head. Rotate skirt upward to provide access to debris tray.
 - d. Grab end of the tray with right hand and slide tray out with left hand.
 - e. Lift center of tray with right hand and slide tray out with left hand.
 - f. Empty tray and clean before sliding tray back in. Make sure upper and lower slides are engaged.
 - g. Rotate side skirt down and engage spacer head in rear slot.

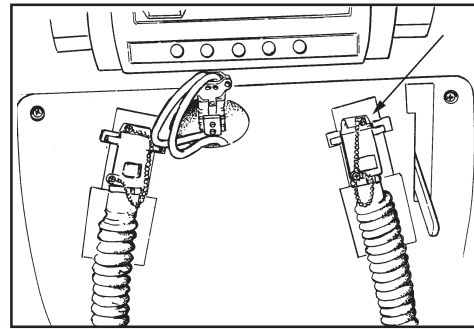

Figure #26

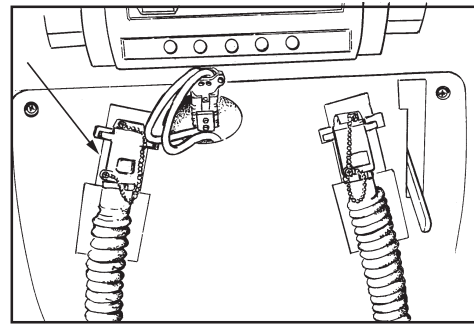

Figure #27

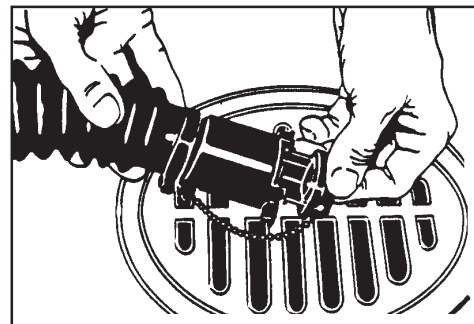

Figure #28

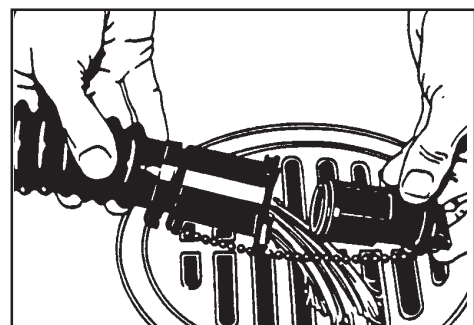

Figure #29

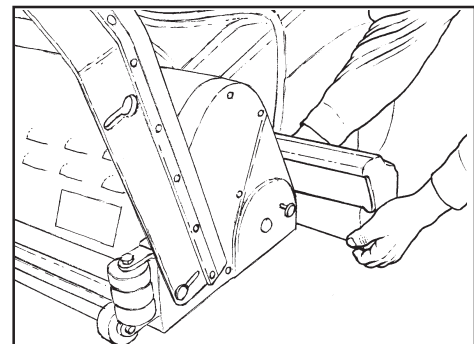

Figure #30

MAINTENANCE

Check the batteries and add distilled water as needed. The correct level is within 1/4 inch of the bottom of the tube in each cell.

CAUTION: Tap water may contain contaminants that will damage batteries. Batteries must be refilled with distilled water only.

WARNING: Lead acid batteries generate gases which can cause an explosion. **NO SMOKING.** Always wear eye protection and protective clothing when working near batteries.

Use a clean cloth and wipe the surface of the machine.

Charge the batteries. See the instruction in the section of this book called "How To Charge The Batteries".

These Maintenance Procedures Must Be Done Every Week:

WARNING: Maintenance and repairs must be done by authorized personnel only. Always empty the solution tank and the recovery tank before doing any maintenance. Keep all fasteners tight.

WARNING: Always wear eye protection and protective clothing when working near batteries. Do not put tools or other metal objects across the battery terminals or the tops of the batteries.

CAUTION: To prevent damage to the machine, and discharge across the tops of the batteries, do not fill the batteries above the bottom of the tube in each cell. Wipe any acid from the machine or the tops of the batteries. Do not add acid to battery after installation.

NOTE: Always turn off key switch before servicing the machine.

WARNING: Always wear eye protection and protective clothing when working near batteries. **NO SMOKING!**

1. To inspect batteries, tip up recovery tank until it locks in up position. See Figure #31.
2. Disconnect the batteries. Use a cloth and a solution of ammonia or bicarbonate of soda to wipe the top of the batteries. Clean the battery terminals. Reconnect the batteries.

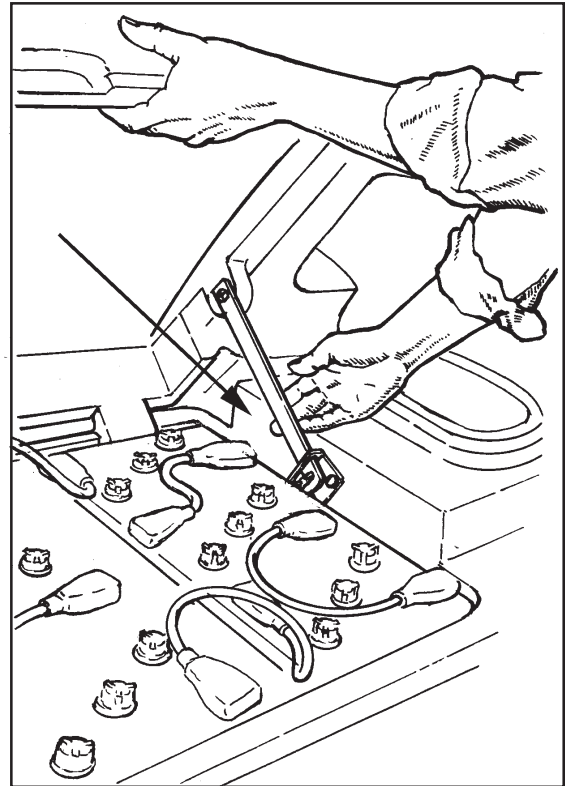

Figure #31

MAINTENANCE

3. Check the hoses for leaks, obstructions and other damages.
4. Check and clean the filter screen in the solution hose. To clean the screen, follow this procedure:
 - a. Turn the connector to the left.
 - b. Remove and clean the filter screen.
 - c. Install the filter screen in the hose. Turn the connector to the right to connect the hose.
5. Use a grease gun to lubricate the drive wheel and the casters. See figure #32.
6. Check tire pressure. Tire pressure should be about 50 psi.
7. Check the squeegee and the scrub brushes or the pad drivers for damage.
8. Check the squeegee and the vacuum hose for damage, leaks and obstructions.

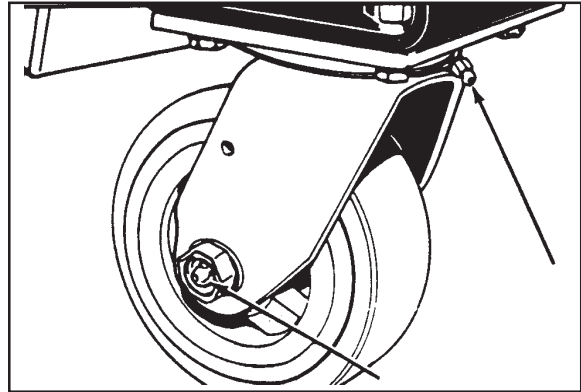

Figure #32

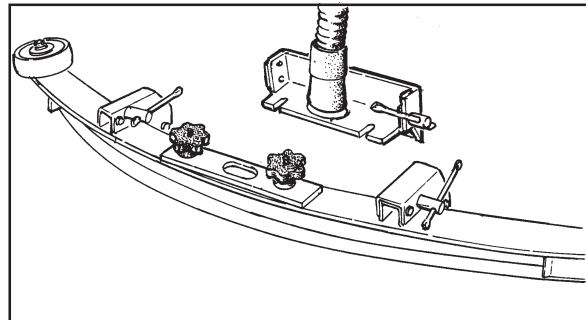

Figure #33

Maintenance For The Squeegee

To remove the squeegee, follow this procedure:

1. Remove the squeegee assembly by loosening the two knobs that attach the squeegee to the machine. Pull the squeegee assembly off. See figure #33.
2. Inspect the squeegee blade.
3. If the blade is worn, turn the blade so that a new edge is in the wiping position.
4. Reinstall squeegee assembly on the machine.

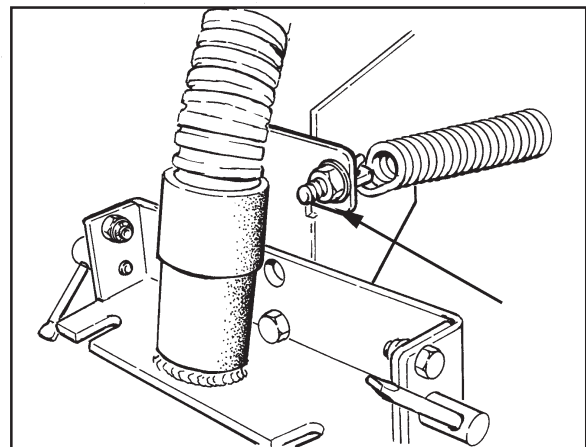

Figure #34

How To Adjust The Squeegee

The following adjustments are set at the factory, however they may require slight adjustment.

Adjusting Squeegee Pressure:

To adjust the pressure, refer to Figure #34. Proper adjustment will produce a uniform flare along the rear blade when the machine is moved forward. To increase pressure, tighten the nuts on each side of the swing arm. To decrease the pressure, loosen the nuts on each side.

MAINTENANCE

Adjusting Squeegee Tilt:

The tilt of the squeegee causes the rear blade to raise up in the center or on the ends, depending on which direction the tilt is changed. For tilt adjustment, refer to figure #35. Loosen left and right screw "X". In order to bring the rear blade down in the center, tip "Y" down. To bring both ends down, tip "Y" up. Make very small adjustments and try it until a uniform flare is achieved. Changing the tilt may also require readjusting the squeegee pressure.

Adjusting Squeegee Blades

When properly installed the front blade should be approximately .06 above the rear blade. See figure #36.

Adjusting Squeegee Support Wheels:

The support wheels should be set at .12 above the floor with the rear blade touching the floor. See figure #36.

⚠ WARNING: Maintenance and repairs must be done by authorized personnel only .

⚠ WARNING: Electrical repairs must be done by authorized personnel only.

Consult your American Lincoln Authorized Service Person to do the service procedures.

Use only genuine American Lincoln parts.

How to Clean the Solution Line

If the solution line becomes clogged, pull the filter assembly out from behind the brush housing (Figure #37 and remove the filter screen (Figure # 38) and clean or replace it. Push filter assembly back inside frame.

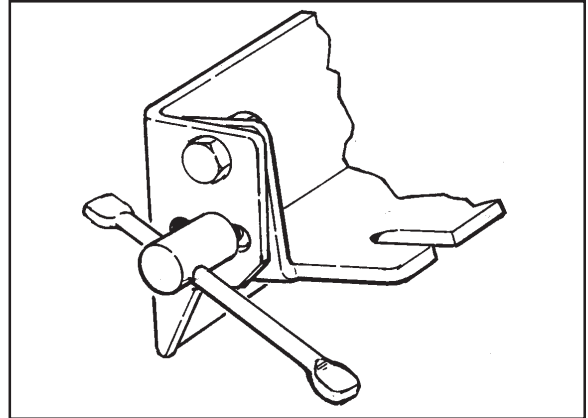

Figure #35

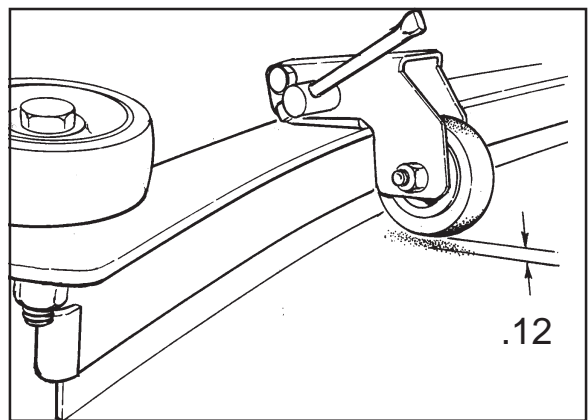

Figure #36

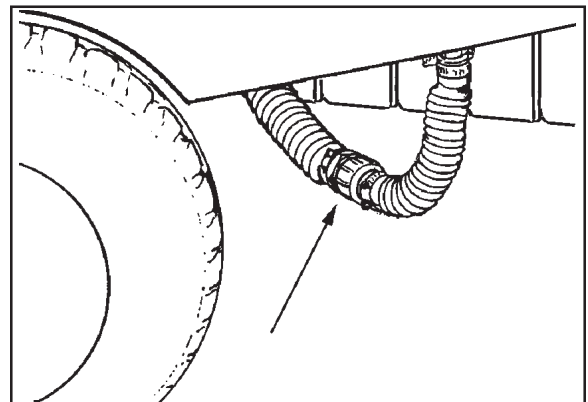

Figure #37

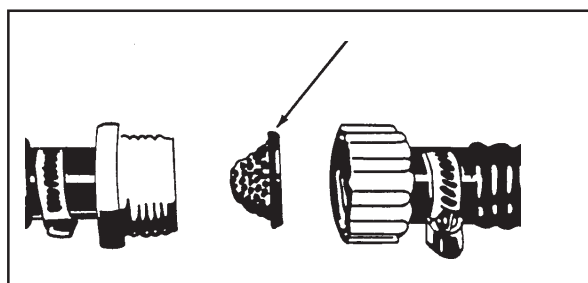

Figure #38

**American Lincoln® Encore 33
Accessories - 1/03**

ACCESSORIES

<u>Description</u>	<u>Part No.</u>
Power Wand System Kit	10674A
ESP Recycle System Kit	10675A
Soft Caster Asm.	52127A
American Lincoln Care Kit	14607A
Drive Wheel, Foam Filled	59955A
<i>Imperial</i> Electric Parking Brake Kit	10684A
Accessory Bag	30070A
Poly Dur Protectant	50478A

Optional Squeegee Blades

Blade	Type	Material	Length	Part No.
Front	Optional	Urethane, Ribbed (60)	40.25"	30953A
Front	Optional-Grout	Urethane, Notched, 1/16" (80)	41.00"	30958A
Rear	Optional	Nitrile, Solid (40)	42.12"	30937A

Brushes:

<u>Size</u>	<u>Description</u>	<u>Part No.</u>
33"	Polypropelene	30261A
33"	Nylon	30262A
33"	Clean Grit	30263A
33"	Super Grit	30264A

American-Lincoln®

Encore 33HD Cylindrical Section II Parts and Service Manual

(70454A)

HOW TO CORRECT PROBLEMS IN THE MACHINE

PROBLEM	CAUSE	ACTION
<p>The machine does not remove all the water from the floor.</p>	<p>The squeegee is up</p> <p>The vacuum tank is full.</p> <p>The screen filter is dirty.</p> <p>There is an obstruction or damage in the squeegee, squeegee hose or standpipe.</p> <p>The vacuum motor is not running.</p> <p>The squeegee hose is disconnected.</p> <p>The squeegee blade is damaged, worn, or incorrectly installed.</p> <p>The squeegee pressure is not correctly adjusted.</p> <p>The gaskets on the cover of the recovery tank are damaged.</p>	<p>Lower the squeegee.</p> <p>Drain the tank.</p> <p>Clean the screen filter.</p> <p>Remove the obstruction or repair the damage.</p> <p>Check for tripped breaker. Have an authorized service person make repairs.</p> <p>Connect the hose.</p> <p>Turn or replace the squeegee blade. Correctly install the squeegee blade.</p> <p>Adjust the pressure of the squeegee.</p> <p>Replace the gaskets.</p>
<p>The batteries do not give the normal running time.</p>	<p>The battery terminals are dirty or damaged.</p> <p>The electrolyte level is too low.</p> <p>The batteries are not fully charged.</p> <p>The charger is damaged.</p> <p>The battery is defective.</p> <p>The batteries are disconnected.</p>	<p>Clean the terminals and connectors. Replace the damaged cables. Charge the batteries.</p> <p>Add distilled water to each cell and charge the batteries.</p> <p>Charge the batteries for a full 16 hour charge.</p> <p>Have an authorized service person repair the charger.</p> <p>Check voltage of each cell while discharging.</p> <p>Connect the batteries.</p>
<p>The cleaning is not even.</p>	<p>The scrub brushes are worn.</p> <p>There is damage to the brush assembly, casters or the solution valve.</p> <p>The brush motors are not running</p> <p>The solution level is low.</p>	<p>Replace the scrub brushes.</p> <p>Have an authorized service person make the needed repairs.</p> <p>Check for tripped breaker, reset. Check for loose connections.</p> <p>Fill the solution tank.</p> <p>NOTE: If the motors continue to stop consult an authorized service person.</p>
<p>The machine does not run.</p>	<p>The machine loses power.</p>	<p>Reset the circuit breaker.</p> <p>Check wire connection to traverse motor.</p> <p>Replace the fuses.</p> <p>Check the batteries connections.</p> <p>Check parking brake override lever position (if installed)</p> <p>NOTE: If the motors continue to stop, consult an authorized service person.</p>

American-Lincoln®
Encore 33HD Cylindrical
Swing Arm Assembly Drawing 5/04

Ref #	Part No.	Description	Qty
1	57275A	Pulley	2
2	87623A	Washer, Nylon 1¼x¼x1/8	2
3	60452A	Swing Arm, Front	1
4	86004A	Screw, .25-20 x 1½	2
5	85730A	Screw, .375-16 x 1¼	1
6	81104A	Nut, Hex ESNA SS	5
7	38021A	Strap	1
8	61679A	Cable, Lower	1
9	51613A	Bumper	1
10	920110	Nut, ESNA	2
11	60454A	Swing Arm, Rear	1
12	920256	Nut, Hex	2
13	81105A	Nut, ESNA SS	1
14	920296	Nut, 10-24 ESNA SS	1
15	962798	Screw, 10-24 x .50	1
16	87624A	Washer, Nylon 1½x¼x1/8	2
17	80015A	Screw, Shoulder	1
18	53423A	Spring, Squ. Pressure	2
19	68016A	Stud	2
20	170915	Screw, SS Hex	2
21	64905A	T Handle	3
22	980651	Washer, Flat .312	1
23	60678C	Pivot Bracket	1
24	25201A	Knob	2
25	35192A	Hose, Squeegee Rec.	1
26	61267A	Tube Bracket	1
27	81217A	Nut, ½-20	1
28	920208	Nut, Hex ¼-20	1
29	980657	Washer, ¼ Lock	1
30	87625A	Washer, Nylon 1¼x¼x1/32	4
31	81303A	Nut, ¼-28	1
32	87026A	Washer	4
33	87031A	Washer, 3/8 Flat	1

American-Lincoln®
Encore 33HD Cylindrical
Squeegee Assembly Drawing 1/03
Drawing #18816K

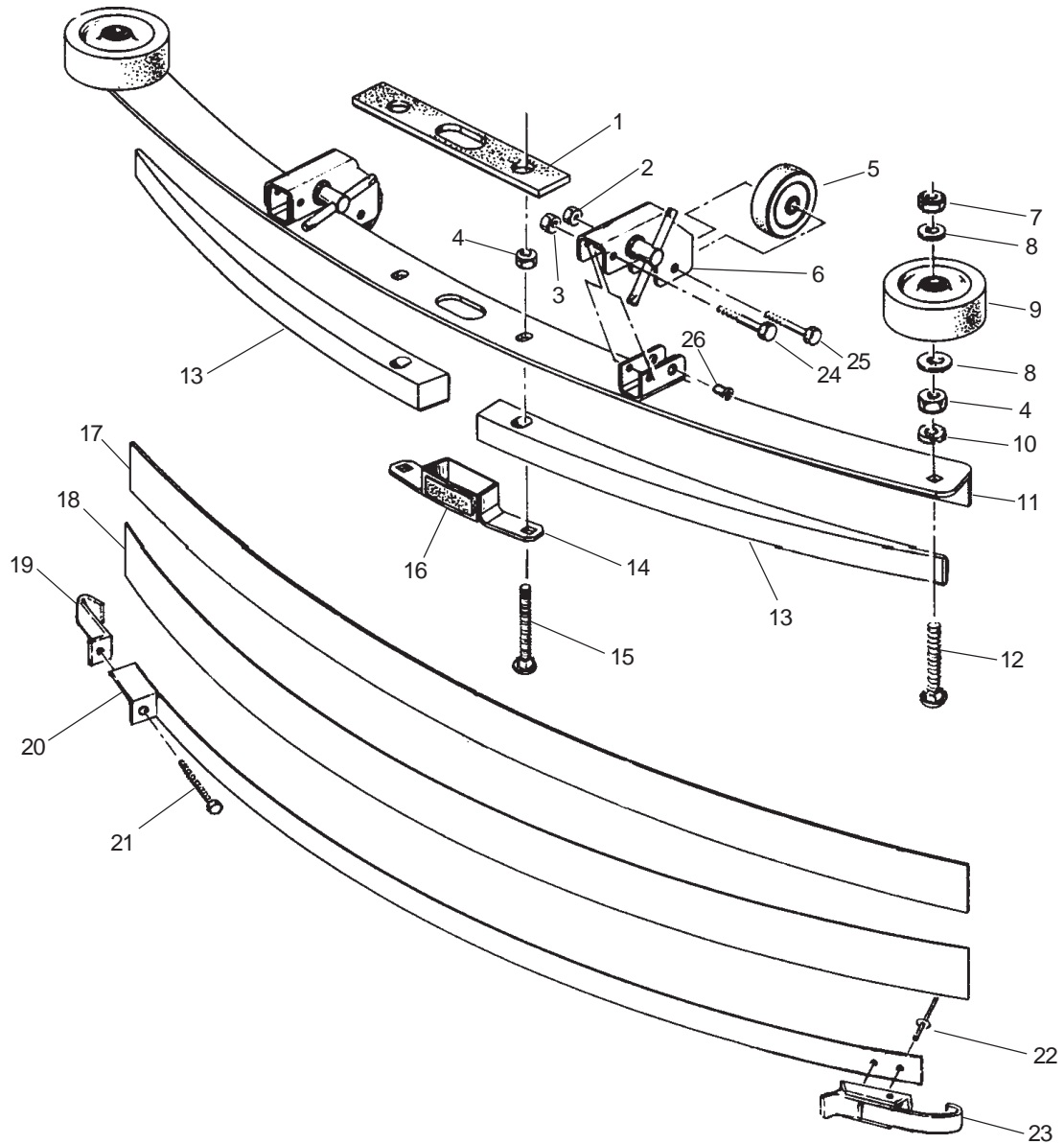

* Apply antiseize to threads

American-Lincoln®
Encore 33HD Cylindrical
Squeegee Assembly Parts List 1/03
Drawing #18816K

Ref #	Part No.	Description	Qty
1	34260B	Squeegee Gasket	1
2	920110	Nut, ESNA	3
3	81104A	Nut, Hex ESNA SS	6
4	81301A	Nut, Jam SS	4
5	59971A	Wheel	2
6	65975A	Wheel Mount Bracket	2
7	920248	Nut, Jam	2
8	980645	Washer, Flat	4
9	59950A	Guide Wheel	2
10	980638	Washer, Lock	2
11	69674A	Squeegee Base	1
12	85610A	Screw, PN Phillips	2
13	38711A	Spacer	2
14	62712A	Air Duct	1
15	80011A	Screw, .375-16 x 3.00	2
16	37016A	Grip Pad	1
17*	30915A	Blade, Inner	1
18*	30913A	Blade, Outer	1
19	62421A	End Clamp	1
20	62443A	Clamp, Weld	1
21	86004A	Screw, .25-20 x 1.50 Hex	1
22	170932	Rivet	2
23	55722A	Squeegee Strap Latch	1
24	85702A	Screw, .25-20 x 1.75	2
25	85816A	Screw, .312-18 x 1.75	2
26	54766A	Insert, Threaded ⁵ / ₁₆ -24	2

* See accessory page

NOTE: When changing squeegee blades, it might be necessary to loosen screw #15; install and secure blades with clamp #20; then retighten screw #15. This will allow for different thickness.

American-Lincoln®
Encore 33HD Cylindrical
Traverse System Assembly Drawing 1/03
Drawing 19021A

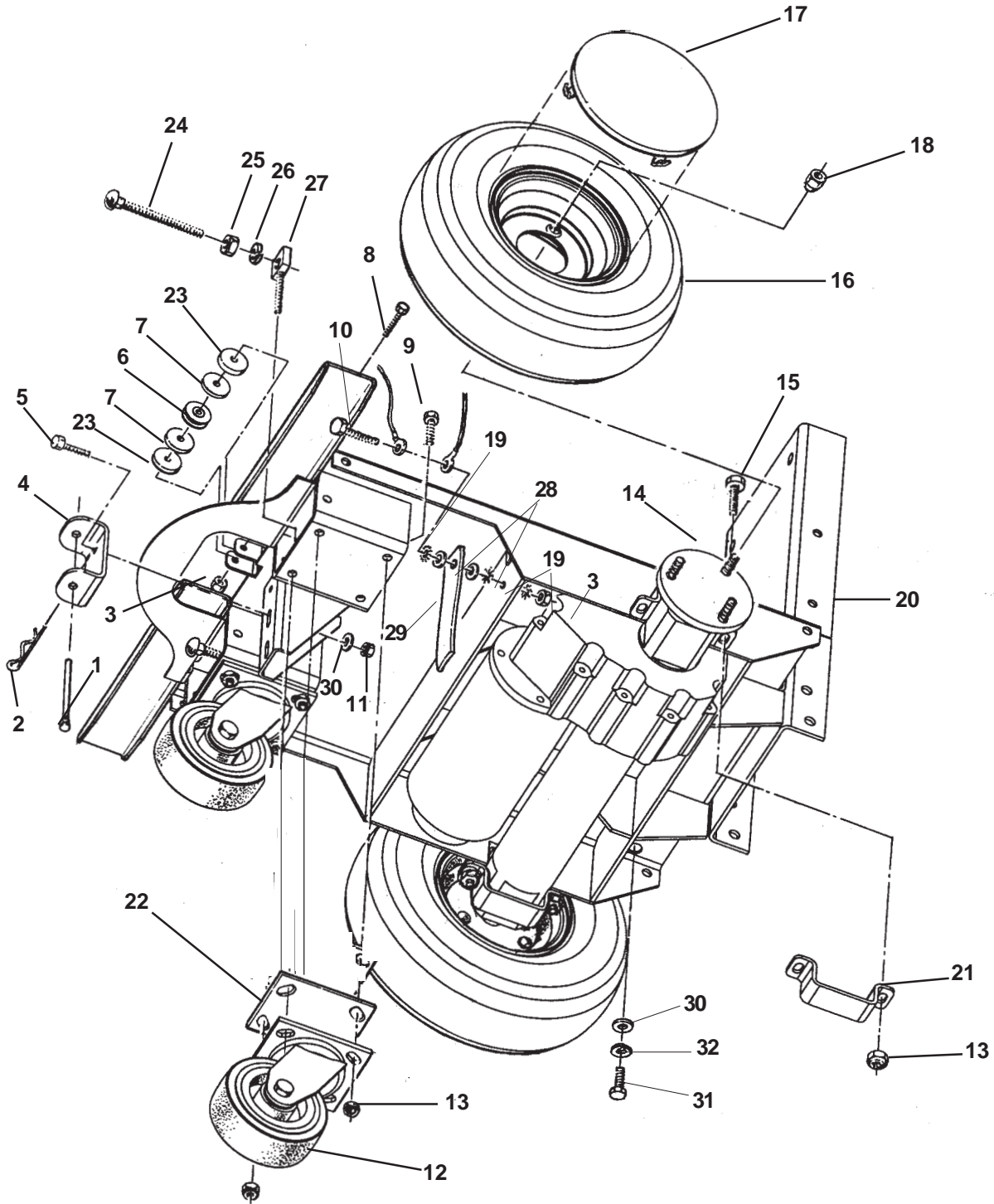

American-Lincoln®
Encore 33HD Cylindrical
Traverse System Assembly Parts List 1/03
Drawing 19021A

Ref #	Part No.	Description	Qty
1	66531A	Swing Arm Pin	1
2	836711	Hair Pin	1
3	81104A	Nut, .25-20 ESNA	2
4	69877A	Swing Bracket	1
5	85811A	Screw, .312-18 x .75	2
6	57275A	Cable Pulley	1
7	87623A	Washer, Nylon 1¼x¼IDx.120	2
8	86004A	Screw, .25-20 x 1.50	1
9	85703A	Screw, .375-16 x 1.50	6
10	85700A	Screw, .25-20 x 1	1
11	920110	Nut, .312-16 ESNA	2
12	899769	Caster Assembly	2
13	81105A	Nut, .375-16 ESNA	12
14	59116A	Transaxle, Imperial (see page 46, 45 for parts)	1
15	85730A	Screw, Hex	4
16	59969A	Wheel Assembly*	2
	59955A	Wheel, Foam Filled (opt.)	2
17	32417B	Wheel Cover	2
18	81221A	Lug Nut, 50-20 UNF	6
19	980614	Washer, Star Lock .25	3
20	60230A	Main Frame	1
21	65963A	Transaxle Mount	2
22	69712A	Spacer	2
23	87625A	Washer, Nylon 1¼x¼IDx3/32	2
24	80011A	Screw, ¾-16 x 3	2
25	81207A	Nut, ¾-16	2
26	170883	Washer, Lock ¾	2
27	58419A	Stud, ¾M x ¾F	2
28	980205	Washer, .25 Fender	2
29	69639A	Strap, Static	1
30	980645	Washer, Flat ¾	6
31	962244	Screw, ¾-16 x ¾	4
32	980638	Lockwasher ¾	4

*30039A tube, inner (included in item #16) 1 Ref.

American-Lincoln®
Encore 33HD Cylindrical
Brush Head Assembly Parts List 12/03

Ref #	Part No.	Description	Qty	Ref #	Part No.	Description	Qty
1	40607A	Motor, Brush	2	31	52477A	Knob, Clamping	2
NI	10531A	Kit, Motor Brush Replacement	1	32	85806A	Screw, Hex Cap 1/4-20 x .75	12
2	Page 34	Lifting Mechanism	1	33	920110	Nut, Nylock 5/16 - 18	3
3	30305A	Tube Assembly, Solution	1	34	962244	Screw, Hex Cap .375-16 x 1.00	4
4	61334A	Plate, Skirt RH	1	35	980645	Washer, Flat 3/8	4
5	61323A	Plate, Skirt LH	1	36	980638	Washer, Lock 3/8 Lt.	4
6	21059A	Brush Housing	1	37	980657	Washer, Lock 1/4	12
7	30049B	Wheel, 1 x 2 x 5/16	8	38	170857	Nut, Hex 1/2-13	2
8	61328A	Bracket, Roller	2	39	51225A	Bearing, 6292 Sealed	2
9	61320A	Cover, Belt	2	40	167312	Ring, Retaining - Internal	2
10	30267A	Debris, Tray	1	41	61299A	Hub, Driven	2
11	61322A	Plate, Brush Door Mnt.	2	42	962098	Screw, 1/4-20 x 0.75	10
12	61326A	Rail, Debris Tray	1	43	962793	Screw, 3/8-16 x 0.75	2
13	61317A	Motor Cover	1	44	80156A	Screw, Hex Cap 5/16-18 x 4	2
14	61308A	Bearing Carrier	2	45	81104A	Nut, Nylock 1/4 SS	2
15	51226A	Bearing, 6202 Sealed	4	46	980648	Washer, Flat 1/2	2
16	61309A	Shaft, Drive	2	47	80248A	Key, 3/16 Sq x 1/2 Lg	2
17	61319A	Pulley, Brush Drive	2	48	80247A	Key, 1/8 Sq x 3/4 Lg	2
18	61318A	Pulley, Motor	2	49	980626	Washer, Lock 1/2	2
19	61321A	Cover, Brush Door	2	50	80012A	Bolt, Shoulder 5/16 x 1.50	2
20	61293A	Hub, Driver	2	51	962094	Screw, 1/4-20 x 3/8	4
21	467308	Retaining, Ring-Idler Gear Stud	5	52	30312A	Skirt, Side	1
22	61327A	Retainer, Bumper	1	53	61335A	Retainer Skirt	2
23	30306A	Bumper, Front	1	54	80240A	Screw, #10-32 x .375	14
24	61341A	Clamp, Sol. Manifold	1	55	980646	Washer, Flat 1/4	8
25	61336A	Spacer, Side Skirt	4	56	77091A	Label, Moving Parts	2
26	61358A	Bracket, Support	1	57	70682A	Label, Encore 33HD	2
27	53182A	End Cap	2	58	61358A	Bracket, Support	1
28	52569A	Belt, Drive	2	59	930113	Rivet, Pop	4
29	61310A	Shaft, Driven	2	60	52816A	Coupling, QD	1
30	85397A	Screw, #10-24 x 3/8	26	61	722030	Clamp, Hose #6	2
				62	80257A	Washer Neoprene	4

American-Lincoln®
Encore 33HD Cylindrical
Lift Actuator Assembly Drawing 4/03

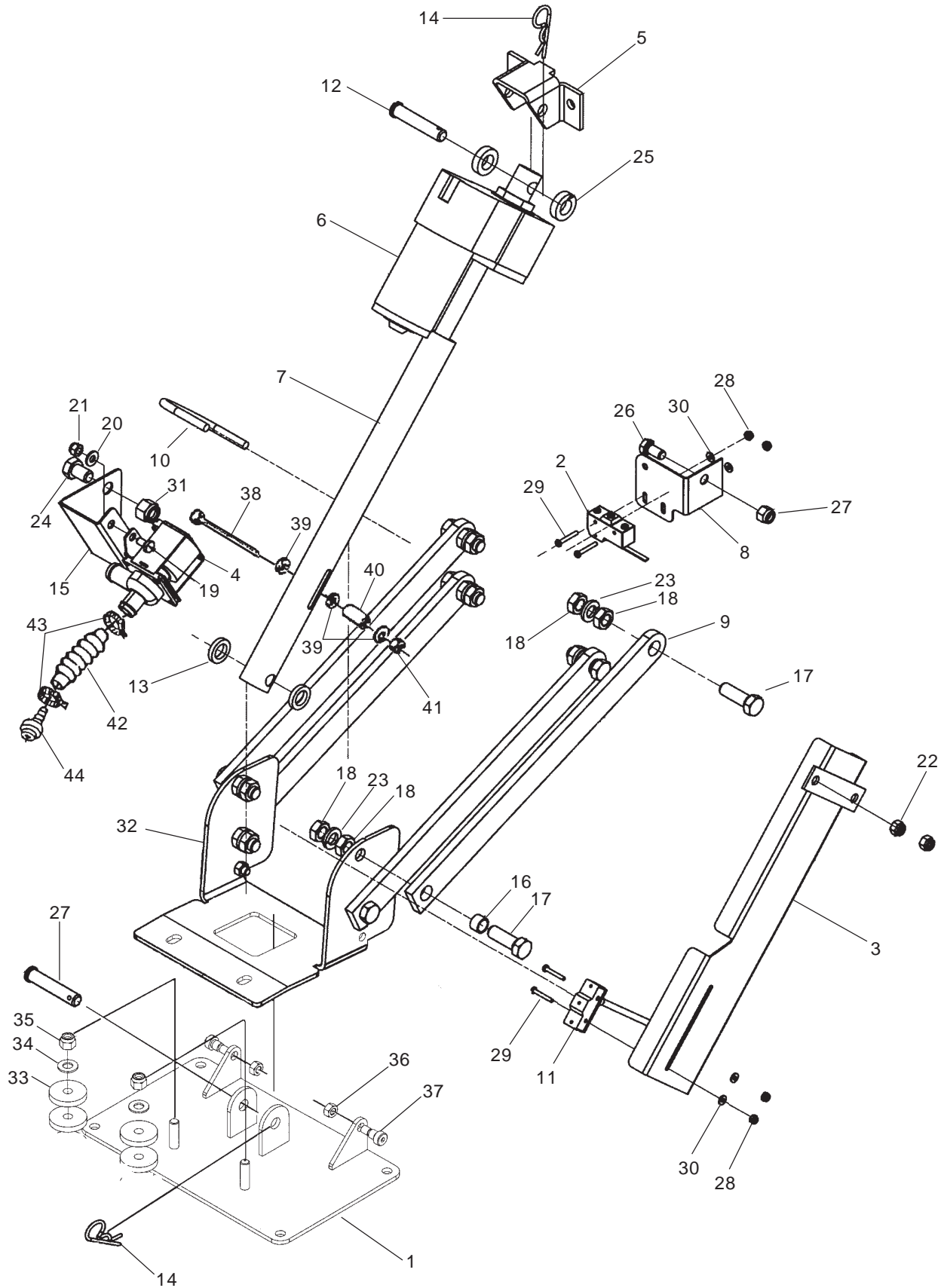

American-Lincoln®
Encore 33HD Cylindrical
Lift Actuator Assembly Parts List 4/03

Ref #	Part No.	Description	Qty
1	61312A	Baseplate, Brush Head	1
2	47374A	Lever, Switch	1
3	61325A	Bracket, Act. Switch	1
4	48703A	Valve, Electric	1
5	60230B	Mainframe Weldment	1
6	50209A	Head Act. Asm.	1
7	69188A	Pressure Tube	1
8	69883B	Bracket, Limit Switch	1
9	61324A	Bar, Linkage	4
10	80044A	U-Bolt	1
11	47422B	Switch, Whisker	1
12	82501A	Pin	2
13	38723A	Spacer, Nylon	2
14	766780	Hairpin	2
15	61316A	Bracket, Valve	1
16	67705B	Bearing, Sleeve	4
17	85838A	Screw, Hex Cap ½-20 x 1½	8
18	920278	Nut, Hex Jam ½-20	16
19	962430	Screw, Hex Cap .250-20 x .50	2
20	980646	Washer, Flat ¼	2
21	81102A	Nut, Nylock ¼-20	2
22	920110	Nut, Nylock 5/16-18	2
23	980626	Washer, Lock ½	8
24	85718A	Screw, Hex Cap .500-13 x .75	2
25	38708A	Spacer, Nylon	2
26	962244	Screw, Hex Cap .375-16 x 1.00	1
27	81105A	Nut, Nylock 3/8-16	3
28	920056	Nut, Nylock #6-32	4
29	962980	Screw, #6-32 x 1	4
30	980608	Washer, Flat #6	4
31	920365	Nut, Nylock .500-13	2
32	61313A	Plate, Lift	1
33	BB-006-08	Bumper, Rubber 1½	4
34	87038A	Washer, Flat 3/8	2
35	81105A	Nut, Nylock 3/8-16	2
36	920110	Nut, Hex 5/16-18	2
37	960952	Bolt, Shoulder 3/8 x 3/8	2
38	85744A	Screw, ¼-20 x 2.75	1
39	87007A	Washer, Flat ¼	3
40	38725A	Spacer	1
41	81104A	Nut, ¼-20 ESNA	1
42	30412A	Hose, Solution	1
43	722030	Clamp, Hose #6	2
44	52817A	Coupling, Hosebarb	1

American-Lincoln®
Encore 33HD Cylindrical
Solution/Recovery System Assembly Drawing 4/03

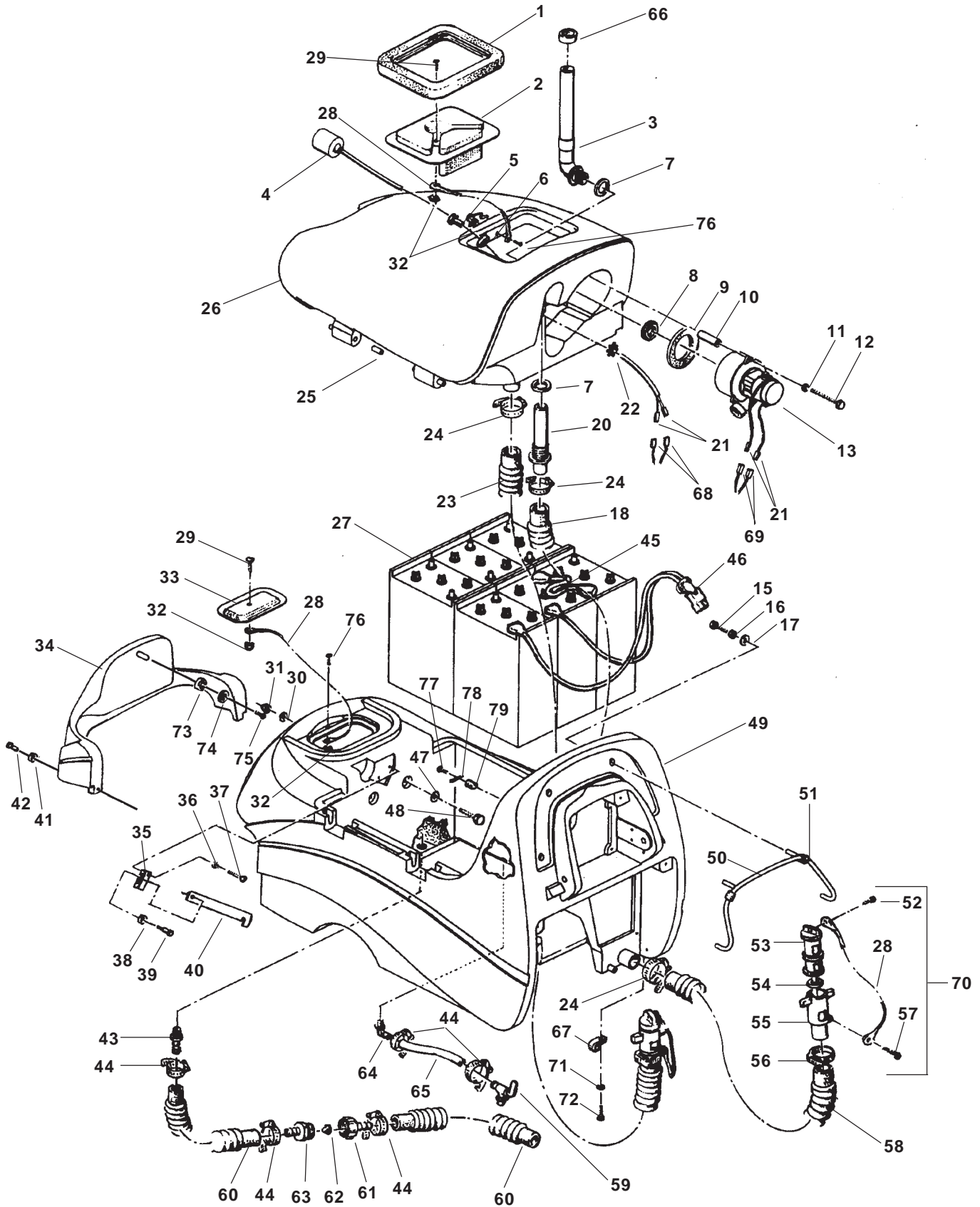

American-Lincoln®
Encore 33HD Cylindrical
Solution/Recovery System Assembly Parts List 8/04

Ref #	Part No.	Description	Qty
1	34265A	Recovery Lid Gasket	1
2	36204A	Recovery Lid	1
3	39338A	Stand Tube	1
4	40002A	Float Switch (include #5 & 2 each #21 & #68)	1
5	56459A	Strain Relief	1
6	87612A	Seal	1
7	837304	O-Ring	2
8*	920797	Nut	1
9	643418	Gasket	1
10	58533A	Vac Motor Spacer	3
11	87026A	Washer, Flat .25	3
12	85728A	Screw, .25-20 x 4.00 Hex	3
13	45019A	Vac Motor (also order 2 each #21 and #69)	1
14	77365B	Label, Battery Installation	1
15	85815A	Screw, .312-18x1.25 Hex	4
16	980652	Washer, Lock .312	4
17	980205	Washer, Fender .312	4
18	35192A	Vac Hose	1
19	77093A	Label, Falling Parts	1
20	30133A	Squeegee Adapter	1
21	41809A	Contact	4
22	82100A	Locknut	1
23	35165A	Rocover Tank Drain Hose	1
24	872010	Hose Clamp	3
25	36903A	Hinge Pin	4
26	30367A	Recovery Tank, incl #25	1
27	881317	Battery - 250 AH - 6 Volt	6
	891384	Battery - 330 AH - 6 Volt	6
	40704A	Battery - 370 AH - 6 Volt	6
28	38020A	Strap	4
29	962798	Screw, 10-24x.5 Pan	2
30	980645	Washer, Flat .375	2
31	81105A	Nut, .375-16 ESNA	2
32	920296	Nut, 10-24 ESNA	4
33	36200A	Solution Lid	1
34	30268A	Front Cover	1

*Recommended torque
175 5 inch/ pounds.

(NI*) = Not Illustrated

Ref #	Part No.	Description	Qty
35	69879A	Support Bracket	1
36	170892	Washer, Lock .25	2
37	170915	Screw, .25-20x.75 SS Hex	2
38	87622A	Washer, Nylon ⁵ / ₁₆ x ⁵ / ₈ x ¹ / ₃₂	1
39	80043A	Screw,Shoulder.25-20x25	1
40	69548A	Recovery Tank Support	1
41	85700A	Washer, ¼ Flat	2
42	980646	Screw, ¼-20 x 1	2
43	50359A	Barb, ½ NPTF x ¾ Hose	1
44	722030	Hose Clamp	6
45	842406	Series Cable - 9"	3
	41206A	Series Cable - 16"	2
46	41208A	Battery Cable	1
47	87054A	Washer,Fender .375x1¼	2
48	85703A	Screw, .375-16x 1.50 Hex	2
49	30242A	Solution Tank	1
50	64900A	Stationary Handle	1
51	30454A	Hose	2
52	962987	Screw, 10-24x.375 Pn.	2
53	833901	Drain Valve Handle	2
54	833407	Drain Gasket	2
55	839401	Drain Valve	2
56	832002	Hose Clamp, Drain Valve	2
57	962943	Screw, 8-18x.5 Pn.	2
58	30449A	Drain Hose	1
59	59614A	Battery Drain Valve	1
60	30445A	Solution Hose	2
61	50358A	Connector	1
62	838517	Filter Screen	1
63	830214	Hose Adapter	1
64	822802	Elbow	1
65	30453A	Hose	1
66	58069A	Vac Filter	1
67	98465A	Clamp, Metal	1
68	43402A	Housing, Blue	2
69	43401A	Housing - Black	2
70	839410	Asm., Drain Valve	1
71	980657	Washer, ¼ Lock	1
72	962139	Screw, ¼-20x5/8	1
73	39713A	Washer, Rubber	1
74	87032A	Washer	1
75	85524A	Screw	1
76	962666	Screw	2
77	962113	Screw 10-32x1	1
78	51867A	Cable Clamp	1
79	81800A	Well Nut	1
80	77092A	Label, Gases & Chem.	1

American Lincoln®
Encore 33HD Cylindrical
Control Housing Assembly Drawing 12/03
Drawing# 13713A

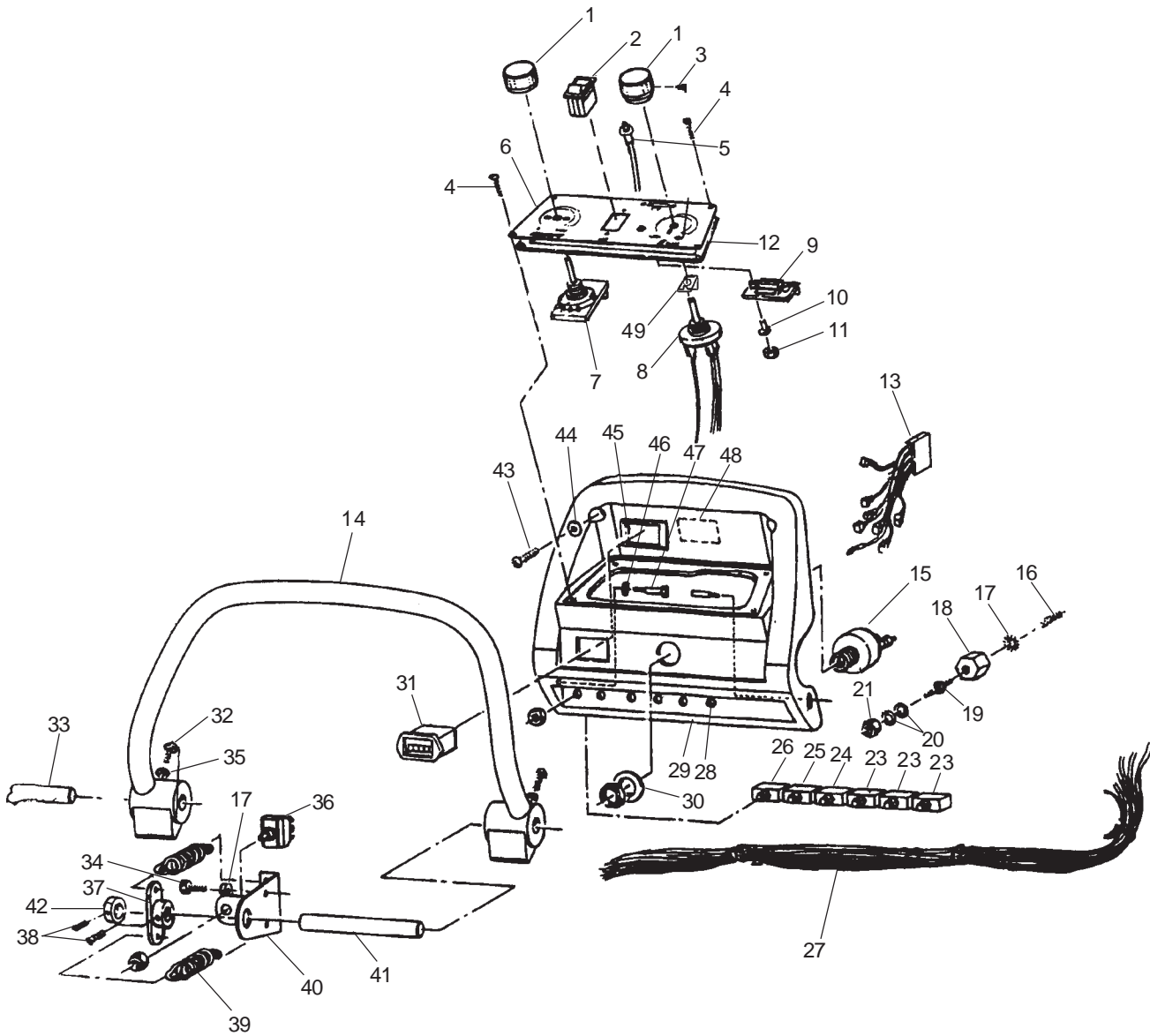

American Lincoln®
Encore 33HD Cylindrical
Control Housing Assembly Parts List 12/03

Ref #	Part No.	Description	Qty
1	55502A	Knob	2
2	47381B	Switch, Head up & down Rocker	1
3	962262	Screw, 8-32 x .25 Set	2
4	85612A	Screw, 10-24 x .375 Pn.	6
5	53031A	Switch	1
6	77343B	Control Panel Label	1
	60058A	Control Panel	1
7	44308B	Solution Flow Module	1
8	40623A	Speed Control Harness	1
9	44416B	Battery Meter	1
10	38724B	Spacer	2
11	920056	Nut, 6-32 ESNA	2
12	30022A	Gasket, Panel	1
13	40623A	Harness, Traverse	1
14	24309B	Control Handle	1
15	47380A	Key Switch	1
15A	55413A	Key, Spare	1
16	170781	Screw, ¼-20 x ¾ Set	1
17	980657	Lock Washer	3
18	854849	Insulator	1
19	83302A	Stud	1
20	87026A	Washer	2
21	81104A	Nut, ¼-20 ESNA	1
23	41448A	Circuit Breaker 30A Scr.	3
24	41422A	Circuit Breaker 25A Scr.	1
25	41423A	Circuit Breaker 5A	1
26	41430A	Circuit Breaker 1.5A	1
27	40179B	Main Harness	1
28	60042A	Stud, 5/16 x ¼-20 Thread	1
29	35252B	Control Housing	1
30	87052A	Nylon Washer, Key Switch	1
31	912226	Hour Meter	1
32	85390A	Screw, .25-20 x 1.25 Pn	2
33	66549A	Pin, Left Hand	1
34	962139	Screw, .25-20 x .62	2
35	170892	Washer, Lock .25	2
36	10052A	Toggle Switch	1
37	60662A	Centering Bracket	1
38*	962304	Screw, Set .312-18 x .5	4
39	53038A	Control Handle Spring	2
40	61266A	Control Bracket	1
41	66548A	Pin, Right Hand	1
42	61651A	Collar	1
43	85391A	Screw, .25-20 x .62 Pn	2
44	87007A	Washer	2
45	66871A	Retainer Key/Hour Meter	1
46	980651	Washer, Nylon IDxODx.034	1
47	80043A	Screw, Shoulder	1
48	77351C	Label, Control Wiring	1
49	50883A	Potentiometer Retainer	1
NI	42909A	Fuse, 5 Amp ACG (included w/item#27)	2

*#38 must use red loctite set screws.

American Lincoln®
Encore 33HD Cylindrical
Rear Cover Assembly Drawing 1/03

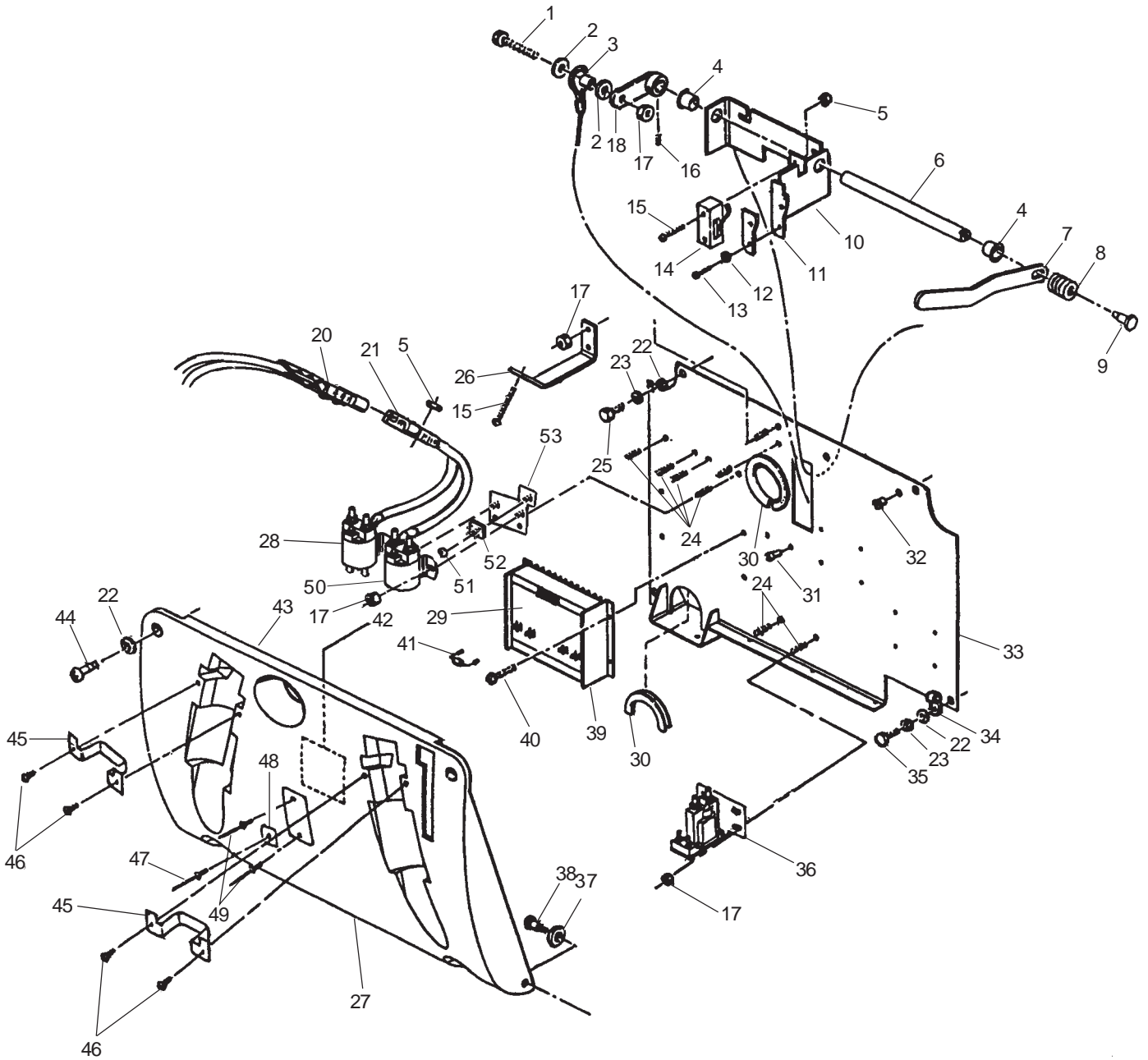

American Lincoln®
Encore 33HD Cylindrical
Rear Cover Assembly Parts List 1/03

Ref #	Part No.	Description	Qty
1	85700A	Screw, .25-20x1.00 Hex	1
2	87026A	Washer, Flat .25	2
3	608210	Spacer	1
4	902731	Nylon Bearing	2
5	920056	Nut, 6-32 ESNA	4
6	67476A	Shaft	1
7	65629A	Squeegee Lever	1
8	438360	Spring	1
9	960510	Shoulder Screw	1
10	61265A	Squeegee Lift Bracket	1
11	68643A	Wear Plate	1
12	980675	Washer	2
13	962546	Screw, 10-24 x .50 Pn	2
14	47388A	Switch	1
15	962980	Screw, 6-32 x 1.00 Pn	4
16*	962304	Screw, .312-18 x .50 Set	2
17	81104A	Nut, .25-20 ESNA	9
18	65628A	Lever Weld.	1
19	61682A	Upper Cable Assembly	1
20	41208A	Battery Cable	Ref
21	41140A	Cable Assembly	1
22	87007A	Washer	6
23	980657	Washer, Lock	4
24	83307A	Stud, ¼-20	8
25	962139	Screw, .25-20x.62 Hex	5
26	69878A	Plug Bracket	1
27	77079A	Label, w/Brake Warning	1
	77080A	Label, w/o Brake Warning	1
28	41802A	Solenoid - Main	1
29	77194B	Label, Traverse	1
30	193951	Trim, 4½" & 8"	1
31	54763A	Insert	4
32	54764A	Insert	2
33	69372A	Lower Electrical Panel	1
34	98465A	Clamp, Metal ^{7/16}	1
35	85806A	Screw, ¼-20 x ¾ Hex	1
36	40125A	Solenoid - Vac	1
37	980651	Washer	2
38	80043A	Shoulder Screw	2
39	40089A	Traverse, Control Board	1
40	962992	Screw, 8-32 x .74 Pn	4
41	42405A	Diode	1
42	77355A	Label	1
43	32418B	Rear Cover	1
44	85391A	Screw, .25-20 x.62 Pn	2
45	60223A	Hose Bracket	2
46	962957	Screw, 10-16 x ½	4
48	77221A	Serial Tag	1
47	83010A	Rivet, Pop	1
49	930093	Rivet	2
50	41801A	Solenoid, Brush	1
51	60552A	Bracket	1
52	920722	Nut, 10-32 ESNA	1
53	912287	Rectifier	1

*#16 must use red loctite.

American-Lincoln®
Encore 33HD Cylindrical
Vac Motor Assembly #45019A 1/03

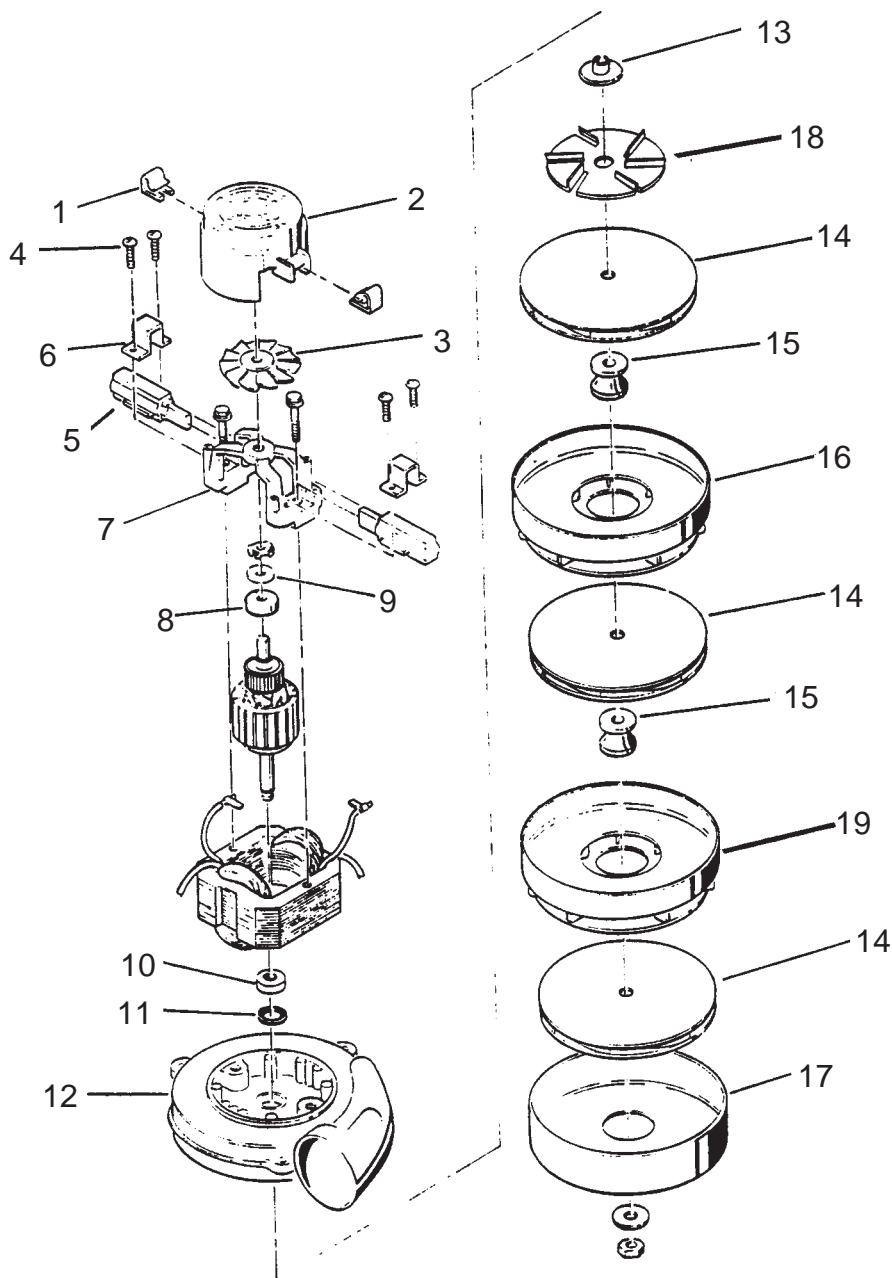

Ref #	Part No.	Description	Qty
1	51913A	Clip (optional)	2
2	54809A	Housing	1
3	53905A	Fan	1
4	85303A	Screw - 8-32 x 3/8	4
5	40830A	Carbon Brushes	2
6	51914A	Clamp	2
7	50618A	Bracket	1
8	53100A	Disc	1
9	902679	Bearing - Ball	1
10	902648	Bearing - ball, radial	1

Ref #	Part No.	Description	Qty
11	59803A	Washer - neoprene	1
12	50610A	Bracket and shell	1
13	58501A	Spacer	1
14	53914A	Fan - Rotating	3
15	658201	Spacer	2
16	53908A	Fan - Stationary	1
17	658506	Shell	1
18	53995A	Fan, Air Seal	1
19	53996A	Fan, Stationary	1

Clarke®
Encore L33/L38
Imperial Transaxle Parts 12/03
PN59116A
Transaxle has black motor
All models after SN#YH

PERMANENT MAGNET MOTOR
MFG. IN USA

Model	4BC-2800	HP	.50
RPM	1200	Ins. Cl.	F
Volt	36 VDC	Mount	Flange
AMP.	15	Shaft	Tang
Duty	Cont	Ser. No.	
Date			
16:1 Ratio			

1 To replace coupler
 remove these two
 screws (Black)
 to separate the
 motor from gearbox
 to allow access to
 coupler

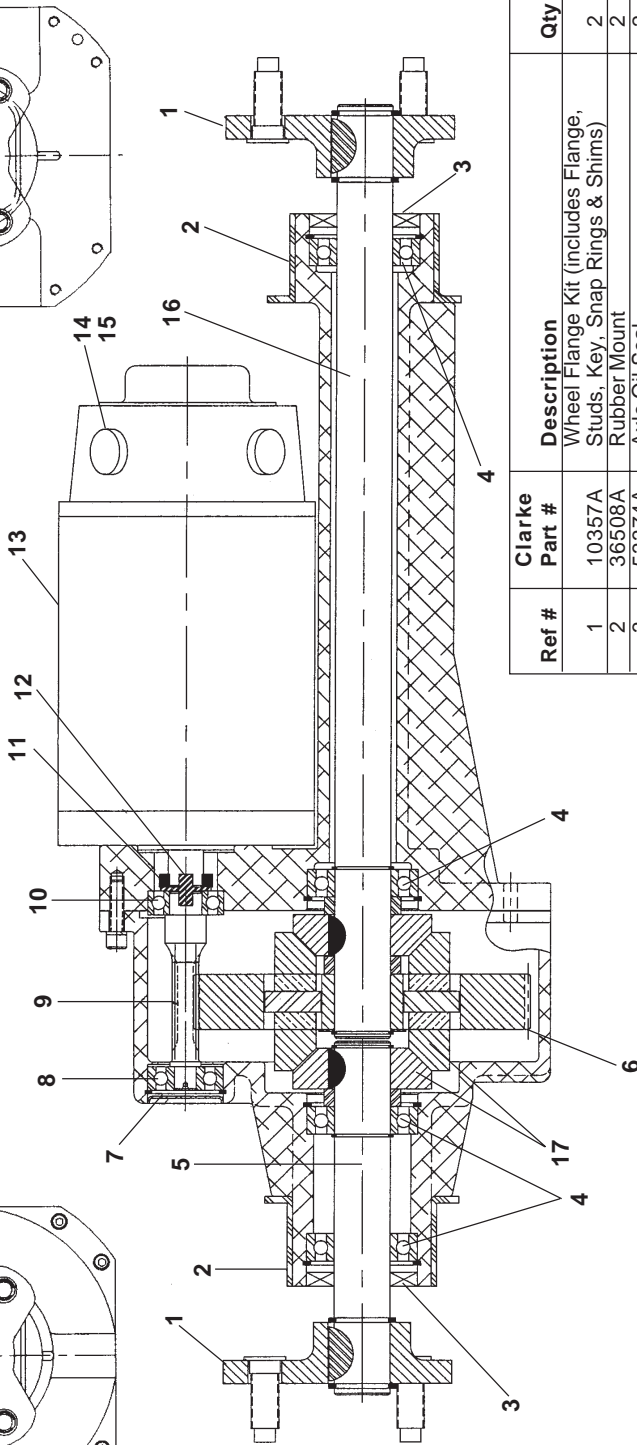
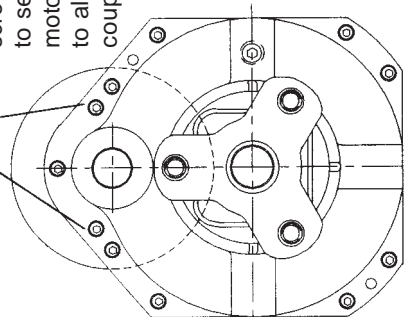
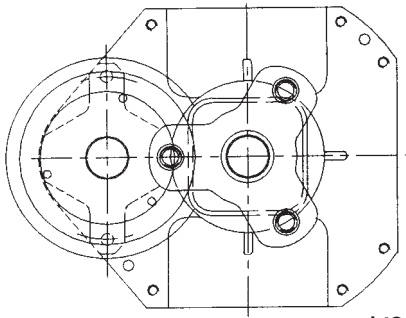

Ref #	Clarke Part #	Description	Qty
1	10357A	Wheel Flange Kit (includes Flange, Studs, Key, Snap Rings & Shimms)	2
2	36508A	Rubber Mount	2
3	53374A	Axle Oil Seal	2
4	53375A	Axle Bearing	4
5	53376A	Short Axle	1
6	53377A	Output Gear	1
7	53378A	Input Plug	1
8	53379A	Outer Pinion Bearing	1
9	53380A	Pinion	1
10	53381A	Inner Pinion Bearing	1
11	52663A	Steel Ring, Coupler	1
12	69195A	Rubber Coupler	1
13	45048A	Motor	1
14	51720A	Brushes w/Springs (Set of 4)	1
15	30074A	Motor Brush Cap (Internal Threads)	4
	53382A	Motor Brush Cap (External Threads)	4
16	53383A	Long Axle	1
	54282A	Gearbox Asm w/o motor	1
17	53435A	Miter Gear	4

Parking Brake Spare Parts		Qty
Part No.	Description	
53384A	Pad, Friction	1
53385A	Hub, Shaft	1
80121A	Key, 4 MM - Hub	1
80122A	Set Screw, M3 - Hub	1

American-Lincoln®
Encore 33HD Cylindrical
36 Volt Battery Charger (40506A, 40507A, 40505A, 40514A, 40515A) 1/03

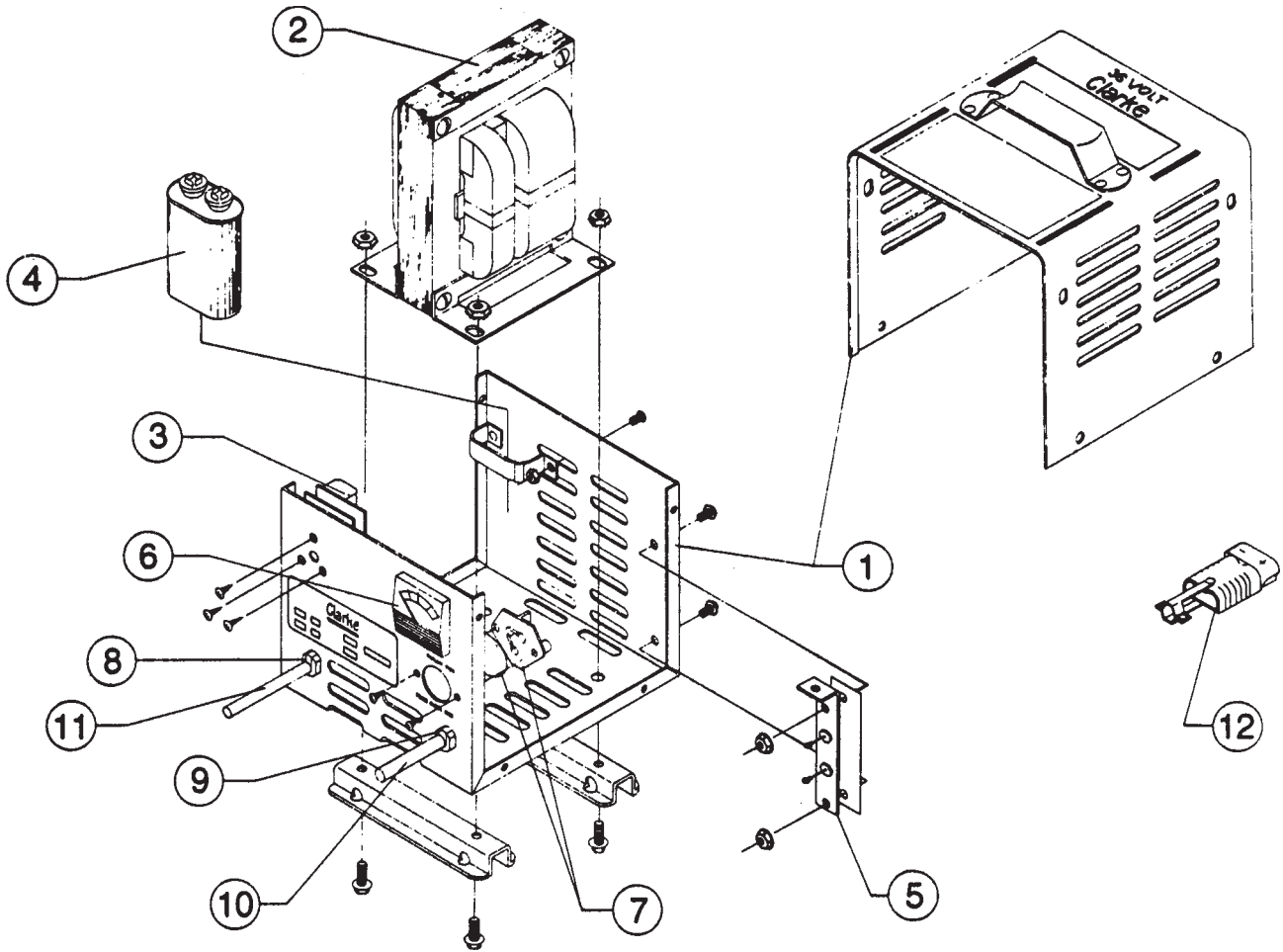

WARNING: All electrical repairs must be performed by qualified personnel only.

PARTS LIST FOR BATTERY CHARGERS

40506A - 36 Volt D.C., 25A, 115 Volt A.C., 60 Hz
 40505A - 36 Volt D.C., 25A, 230 Volt A.C., 50 Hz
 40507A - 36 Volt D.C., 25A, 230 Volt A.C., 60 Hz
 40514A - 36 Volt D.C., 36A, 115 Volt A.C., 60 Hz
 40515A - 36 Volt D.C., 36A, 230 Volt A.C., 50Hz

Ref #	Description	Charger Model Number				
		40506A Part #	40507A Part #	40505A Part #	40514A Part #	40515A Part #
1	Charger Case	42503A	42504A	51959A	41139A	51856A
2	Transformer	48400A	48412A	48401A	Ref	Ref
3	Electronic Timer Kit	41102A	41103A	41103A	41102A	41103A
4	Capacitor, 6 Mfd., 660 V.A.C.	912132	912132	912132	912132	912132
5	Heat Sink Assembly	912212	912212	912212	43301A	43301A
6	Ammeter	40200A	40200A	40200A	40210A	40210A
7	Fuse Assembly	912382	912382	912382	42704A	42704A
8	Strain Relief, A.C. Cord	837525	837525	837525	747553	747553
9	Strain Relief, D.C. Cord	747553	747553	747553	737502	737502
10	D.C. Cord Assembly	51973A	51973A	51973A	42303A	42303A
11	A.C. Cord Assembly	51974A	908947	908947	51974A	51857A
12	D.C. Plug	911185	911185	911185	911185	911185
	D.C. Plug Lock Key	795020	795020	795020	795020	795020

American-Lincoln®
Encore 33HD Cylindrical
Battery Charger (40512B & 40506B) Drawing and Parts List 5/06

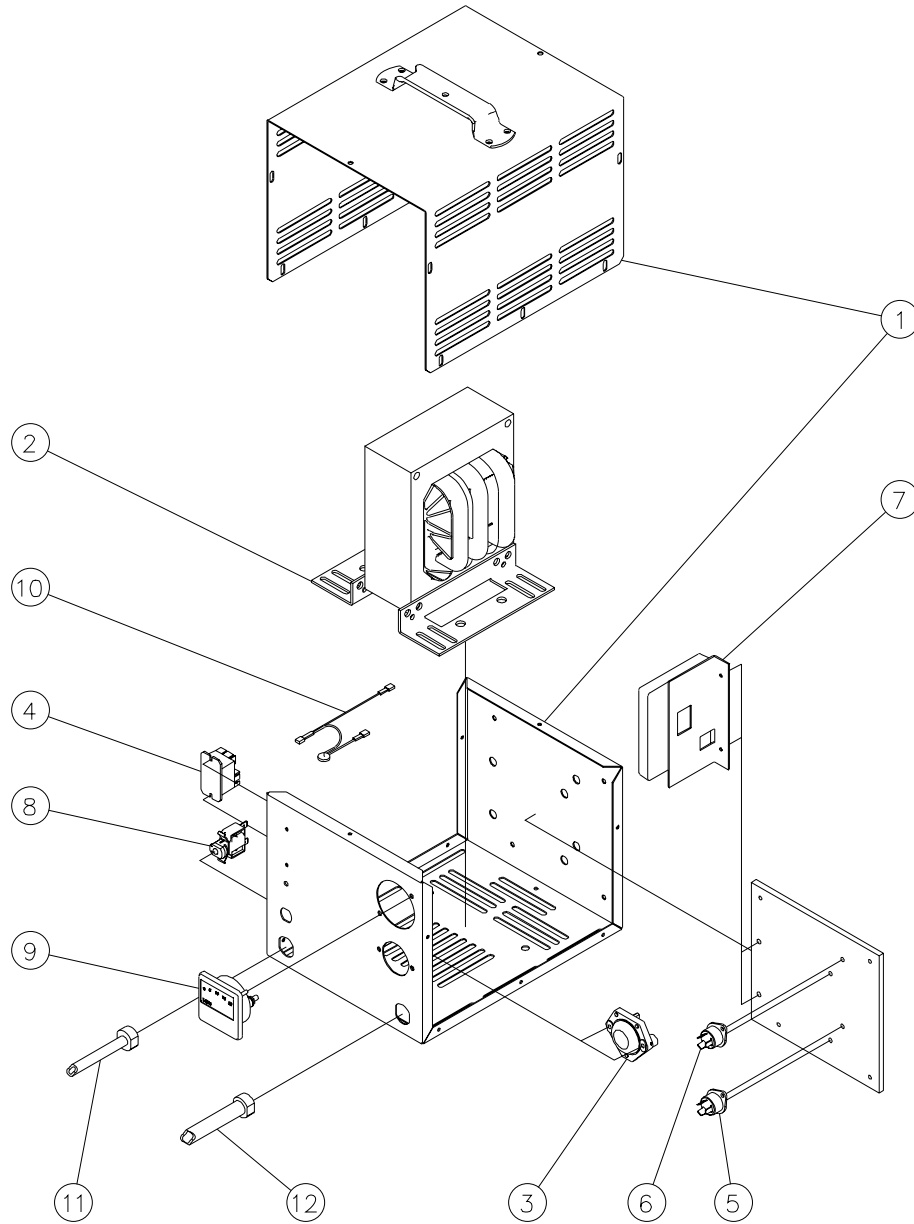

WARNING: All electrical repairs must be performed by qualified personnel only.

REF NO.	DESCRIPTION	40512B 24V 25A	40506B 36V 25A
1	CASE ASSEMBLY		
2	TRANSFORMER ASSEMBLY		
3	FUSE ASSEMBLY	912382	912382
4	D.C. RELAY		
5	SCR ASSEMBLY, BLUE & BROWN WIRES	11085A	11086A
6	SCR ASSEMBLY, VIOLET & WHITE WIRES		
7	ELECTRONIC CONTROLLER ASSEMBLY		
8	A.C. CIRCUIT BREAKER		
9	AMMETER		
10	A.C. SURGE PROTECTION		
11	A.C. CORDSET, 5-15P PLUG AND BUSHING		
12	D.C. CORDSET, SB50 GRAY PLUG W/ KEY		

American Lincoln® Encore 33HD Cylindrical Electrical Schematic 2/03

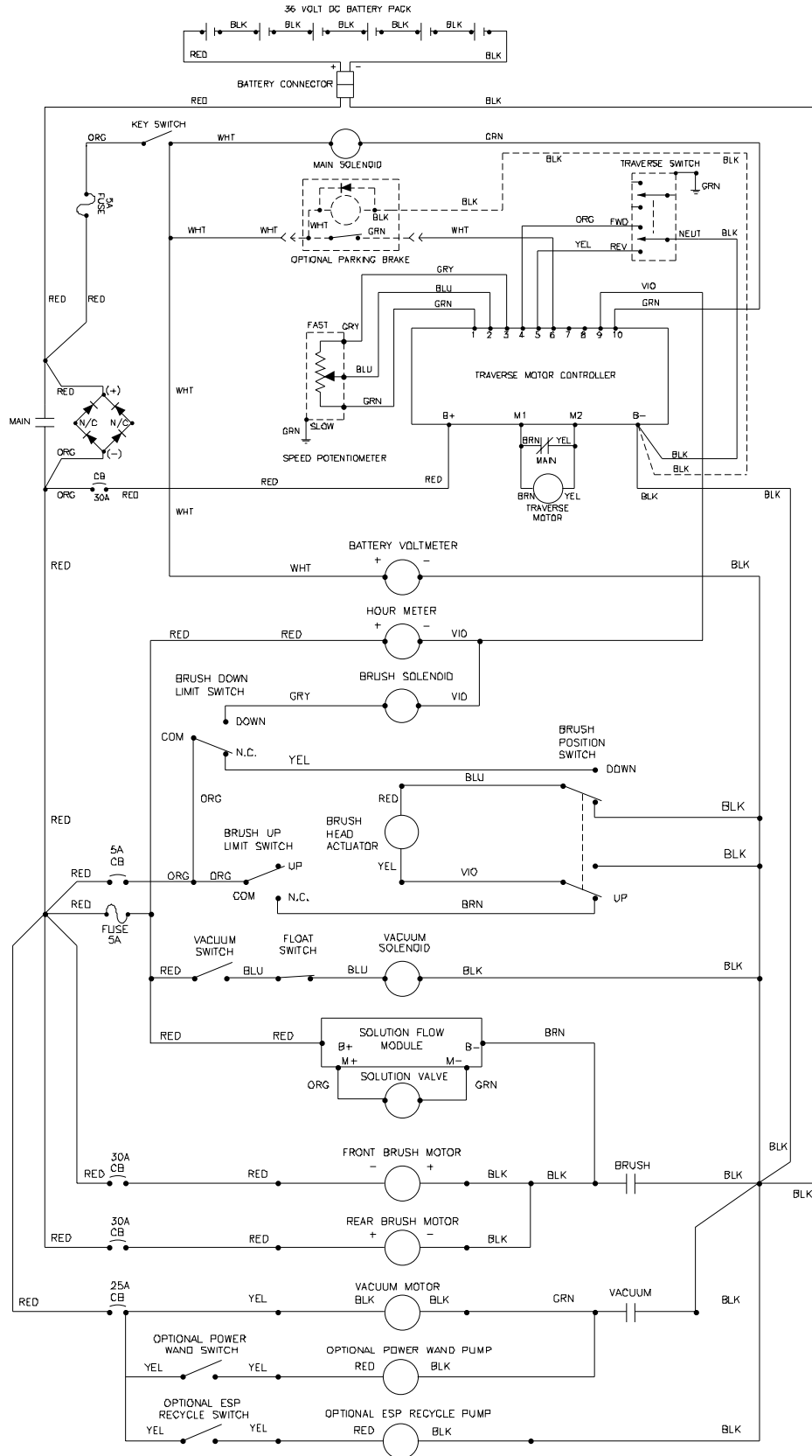

ALTO PRODUCT SUPPORT BRANCHES

U. S. A. Locations

PRODUCTION FACILITIES

Clarke®, Springdale, Arkansas
2100 Highway 265
Springdale, Arkansas 72764
(479) 750-1000
Customer Service - 1-800-253-0367
Technical Service - 1-800-356-7274

American Lincoln®, Bowling Green, Ohio 43402
1100 Haskins Road

SERVICE FACILITIES

Clarke®, Elk Grove, Illinois 60007
2280 Elmhurst Road
(847) 956-7900

Clarke®, Denver, Colorado 80204
1955 West 13th Ave.
(303) 623-4367

Clarke®, Houston, Texas 77040
7215 North Gessner Road
713-937-7717

SERVICE AND SALES FACILITY

American Lincoln® / Clarke, Madison Heights,
Michigan 48071-0158
29815 John R.
(810) 544-6300

American Lincoln® / Clarke, Marietta, Georgia 30066
1455 Canton Road
(770) 973-5225

Clarke®

Clarke American Sanders

A.L. Cook

Customer Service Headquarters and Factory
2100 Highway 265
Springdale, Arkansas 72764
(479) 750-1000

Technical Service
1-800-356-7274

European Locations

PRODUCTION FACILITIES

ALTO Danmark A/S, Aalborg
Blytaekervej 2
DK-9000 Aalborg
+45 72 18 21 00

ALTO Danmark A/S, Hadsund
Industrikvarteret
DK-9560 Hadsund
+45 72 18 21 00

SALES SUBSIDIARIES

ALTO US - Canada, Ontario (Canada)
4080 B Sladeview Crescent Unit 1
Mississauga, Ontario L5L 5Y5
(905) 569 0266

ALTO Overseas Inc., Sydney (Australia)
1B/8 Resolution Drive
Caringbah NSW 2229
+61 2 9524 6122

ALTO Cleaning Systems Asia Pte Ltd., Singapore
No. 17 Link Road
Singapore 619034
+65 268 1006

ALTO Deutschland GmbH, Bellenberg (Germany)
Guido-Oberdorfer-Straße 2-8
89287 Bellenberg
+49 0180 5 37 37 37

ALTO Cleaning Systems (UK) Ltd., Penrith
Gilwilly Industrial Estate
Penrith
Cumbria CA11 9BN
+44 1768 868 995

ALTO France S.A. Strasbourg
B.P. 44, 4 Place d'Ostwald
F-67036 Strasbourg
Cedex 2
+33 3 8828 8400

ALTO Nederland B.V.
Postbus 65
3370 AB Hardinxveld-Giessendam
The Netherlands
+31 184 677 200

ALTO Sverige AB, Molndal (Sweden)
Aminogatan 18
Box 4029
S-431 04 Molndal
+46 31 706 73 00

ALTO Norge A/S, Oslo (Norway)
Bjornerudveien 24
N-1266
+47 2275 1770

AMERICAN-LINCOLN U.S. AND CANADA LIMITED WARRANTY

American-Lincoln warrants to the original end user, each new machine, new accessory and genuine replacement parts against defects in material and workmanship under normal use and service. Our obligation under this warranty is limited to repair or replacement of the defective item at our factory or by an Authorized Service Center. Warranty coverage shall begin on the date of purchase by the original end user (as evidenced by your invoice from the factory or Authorized Dealer). The warranty registration card should be completed and returned within 30 days of purchase. The warranty coverage period is specified below.

GROUP	PARTS¹	LABOR²	TRAVEL^{2,3}
Industrial Rider Machines (Battery)	2 years	6 months	6 months
Industrial Rider Machines (Internal Combustion)	2 years ⁶	6 months ⁶	6 months ⁶
Encore L25HD / L26HD Walk Behind Scrubbers	3 years	1 year	90 days
Encore 20 / 33HD Walk Behind Scrubbers	1 year	1 year	90 days
Encore ² Walk behind Scrubber	3 years	1 year	1 year
Accessories/Replacement Parts ⁴	90 days	none	none
EXCEPTIONS			
Roto-mold Components	8 years	See Note 5	See Note 5
Stainless Steel Tanks	8 years	See Note 5	See Note 5
Vacuum Motors	1 year	1 year	None
Tires (not including rims)	Prorated over 1 year / First 90 days at 100%		
Batteries	Prorated over 1 year / First 90 days at 100%		
Internal Combustion Engines	See Separate Engine Warranty		
External Battery Chargers	As offered by manufacturer		
NOTES:			
1-Parts repaired or replaced are guaranteed for the remainder of the original machine warranty period.			
2-Coverage only applicable to products sold and used in the United States and Canada.			
3-Travel warranty coverage limited to 3 hours of round trip travel time to remedy a defective product or part.			
4-Not sold with the new machine. Includes roto-mold components, stainless steel tanks and vacuum motors when sold separately.			
5-Follows warranty offered on original machine.			
6-Two (2) years or 2,000 hours of normal operation, whichever occurs first.			

This warranty shall not apply to repairs resulting from accidents or misuse, damage in transit, overloading the capacity of the machine, failure due to lack of proper maintenance or care as described in the operating and maintenance instructions. Minor adjustments, such as tightening of screws or bolts not connected with the replacement of parts, are not covered. Replacement of expendable wear items such as scrub brushes, pad holders, carbon motor brushes, bulbs, bags, filters and various rubber/plastic parts are also not covered. Repairs or alterations by an organization other than the factory or an Authorized Service Center are not covered and will void any American-Lincoln warranty as to the parts or systems repaired or altered by a non-authorized organization.

THERE ARE NO WARRANTIES THAT EXTEND BEYOND THE DESCRIPTION OF THE LIMITED WARRANTIES STATED WITHIN. NO OTHER WARRANTY, EXPRESSED OR IMPLIED, INCLUDING BUT NOT LIMITED TO ANY IMPLIED WARRANTY OF MERCHANTABILITY OR FITNESS FOR A PARTICULAR PURPOSE, IS MADE EXCEPT AS EXPRESSLY STATED HEREIN. ANY STATUTORY IMPLIED WARRANTIES, INCLUDING ANY WARRANTY OF MERCHANTABILITY OR FITNESS FOR A PARTICULAR PURPOSE, THAT ARE IMPOSED BY LAW DESPITE THE EXPRESS LIMITATION OR WARRANTIES ABOVE, ARE EXPRESSLY LIMITED TO THE DURATION OF THE WRITTEN WARRANTY. BUYER UNDERSTANDS, ACKNOWLEDGES AND AGREES THAT THE REMEDIES PROVIDED UNDER THIS LIMITED WARRANTY ARE THE SOLE AND EXCLUSIVE REMEDIES AVAILABLE TO THE BUYER. AMERICAN-LINCOLN WILL NOT BE LIABLE FOR ANY OTHER OR ADDITIONAL DAMAGES, INCLUDING BUT NOT LIMITED TO INDIRECT, SPECIAL OR CONSEQUENTIAL DAMAGES ARISING OUT OF OR IN CONNECTION WITH THE FURNISHING, PERFORMANCE, USE OF OR INABILITY TO USE THE MACHINE. ANY EXTENSIONS OF OR MODIFICATIONS MADE TO THIS WARRANTY BY A DEALER/DISTRIBUTOR OF AMERICAN-LINCOLN ARE THE SOLE RESPONSIBILITY OF THE DEALER/DISTRIBUTOR.

All transportation or shipping charges resulting from the return of machines, parts, or accessories shall be the responsibility of the end-user. When returning, please provide an explanation of the problem and include the serial number of the machine as well as the name of the selling organization. The Technical Service department of the authorized Dealer Service Center or the factory will investigate and then contact you.

Transportation of hazardous waste or contaminated equipment is subject to various laws and regulations. In returning machines, parts, or accessories under this limited warranty, the end user must certify in writing that the machines, parts or accessories being returned have not been used for handling, clean up, or disposal of hazardous waste or hazardous materials including but not limited to such things as asbestos, anthrax etc. or if the machines, parts or accessories being returned have been used for handling, clean up, or disposal of hazardous waste or hazardous materials, then the end user must have the machines, parts or accessories decontaminated by licensed and qualified decontamination professionals and provide written certification of this decontamination signed by the decontamination professionals. These machines, parts or accessories are to be returned only to the local American-Lincoln Authorized Service Center for Warranty service along with decontamination certification.

AMERICAN-LINCOLN reserves the right to change its warranty policy without notice. This limited warranty supersedes all prior warranties for machines ordered and shipped after December 31, 2005.

American-Lincoln®

14600 21st Avenue North
 Plymouth, MN 55447-3408
 www.americanlincoln.com
 Phone: 800-331-7692
 Fax: 877-877-2586

©2006 American-Lincoln
 Form L 1858L, 1-06