



Electronic Service Manuals

This electronic document is provided as a service to our customers. We do not create the contents of the information contained in this document. Should you have detailed questions pertaining to the information contained in this document, you may contact Michco, or the manufacturer which provided the original information in this electronic deliverable. Michco's only part in this electronic deliverable was the electronic assembly process. By providing this manual on line we are not guaranteeing parts availability.

You may contact Michco through the following methods:

Phone (517) 484-9312 or (800) 331-3339

2011 N. High St. -- Lansing, Michigan -- 48906

Fax: (517) 484-9836

Email: CustServe@Michco.com

Web site: www.Michco.Com

Parts Web site: www.FloorMachineParts.Com

Order Parts on Line at:

www.FloorMachineParts.Com

Directly to Parts & Service:

By Email: **Shop@Michco.com**

By Fax: (517) 702-2041

By Voice: Use numbers above.

Serving the Cleaning Industry Since 1922

Notice: All copyrighted material remains property of original owners, all trademarks are property of respective owners. Manuals are subject to Manufacturer's reproduction limitations. Originals or reproductions were provided by manufacturers through a request. We make no warranty as to the correctness of information provided in this document and you assume all risk. By placing these manuals on line we are not declaring our corporation to be an manufacturer authorized dealer or provider, please check our web site for authorized manufacturers we represent.



American-Lincoln®



SR9772 SCRUBBER

For American-Lincoln MODELS 510-015, 510-016, 510-017, 510-018

Instructions for Use / Parts List

READ THIS BOOK

This book has important information for the use and safe operation of this machine. Failure to read this book prior to operating or attempting any service or maintenance procedure to your machine could result in injury to you or to other personnel; damage to the machine or to other property could occur as well. You must have training in the operation of this machine before using it.

All directions given in this book are as seen from the operator's position at the rear of the machine.

CHAPTER 1 - CONTROLS & OPERATION

Machine Specifications	1-4 – 1-5
Machine Dimensions	1-6 – 1-7
Safety Precautions	1-8 – 1-9
Machine Information/Preparation	1-10 – 1-11
Scrubber Operation	1-12 – 1-13
The Scrubbing Systems	1-14 – 1-15
Operating the Scrubber Controls	1-16 – 1-17
Operating Instructions	1-18 – 1-26
Service Chart	1-27
Service Instructions	1-28 – 1-33
Troubleshooting - Scrubbing System	1-34
Troubleshooting - Hydraulic System	1-35
Troubleshooting - Camel Recycling Pump	1-36
Troubleshooting - Camel Detergent Pump	1-37
Ordering Parts	1-38

CHAPTER 2 - COMPONENT PARTS LISTS & DIAGRAMS

Mounting Structure	2-2
Scrub Deck/Solution Control	2-4
Scrub Deck Lift (NO Cab)	2-6
Scrub Deck Lift (CAB)	2-8
Squeegees/Squeegee Lift	2-10
Solution Tank	2-12
Solution Vacuum System	2-14
Solution Vac/Washer Hose (CAB)	2-16
Recovery Tank	2-18
Recovery Tank Lid	2-20
Camel Recovery Tank	2-22
Camel Pump Group	2-24
Camel Detergent Tank (NON-CAB)	2-26
Camel Detergent Tank (CAB)	2-28
Hydraulic Manifold Valve	2-30
Hyd. Cylinders & Main Pump Hoses & Fittings	2-31
Hydraulic Motors, Hoses & Fittings	2-32
Brush Drive Motors & Fittings	2-33
Control Panel Assembly	2-34
Decals	2-36
Scrub Deck Hydraulics & Fittings	2-38
Scrub Deck Flap Assemblies	2-40
Hydraulic Schematic	2-41
Electrical Schematic	2-42

CHAPTER 3 - OPTIONS

Brush Options	3-2
Foam-Filled Tires Option	3-3
Catalytic Muffler Option	3-4
Rotating Light Option (Roll Bar)	3-5
Warning Light Option (CAB)	3-6
Vacuum Wand Option	3-7
Transmission Lock-Out Option	3-8
Additional Options	3-9

MACHINE SPECIFICATIONS

DIMENSIONS

Length	137.4 inches (3489 mm)
Width	52.5 to 75.6 inches (1333 to 1920 mm)
Height	94.92 inches (2411 mm)

WEIGHT

Counterweights	925.9 to 1102lbs (420/500 kg)
Weight Cab Model Loaded	11168 lbs. (5076kg)
Weight Cab Model Unloaded	8168 lbs. (3713 kg)
Weight Platform Model Loaded	10384 lbs. (4720 kg)
Weight Platform Model Unloaded	7384 lbs. (3356 kg)

ENGINE

Injection Pump	4-stroke diesel direct injection, Naturally aspirated,3 cylinders:
Bore and Stroke	3.94 x 4.52 inches (104 x 115 mm)
Total Displacement	178.79 in ³ (2930 cm ³)
Compression Ratio	17:1
Torque increase	29%
Corresponding rpm	2000
Max Torque rpm	1400
Oil Cooler	Engine oil-cooled by a heat exchanger using engine coolant.

FUEL SYSTEM

Fuel Pumps speed	Double diaphragm fuel pump on injection pump supply line. Rotary injection pump with centrifugal governor, operating at all speeds and incorporating automatic advance. Type Bosch-VE3.
Fuel Filtration separator.	Mesh filter in the fuel pump; replacement cartridge filter on the injection pump feed line with water separator.
Lubrication	Pressurized by gear pump. Oil filtration: pressurized through pump intake mesh and replacement cartridge filter on engine intake.

ENGINE LUBE PRESSURE

Engine Speed	2000rpm, bar 2.9-3.9, psi 42.24-55.47
--------------	---------------------------------------

Cooling	Water, pressurized circulation by centrifugal pump. Radiator with 3 lines of vertical copper pipes. Cooling fan fitted on same shaft as water pump. Water circulation from engine to radiator thermostatically controlled.
---------	--

AIR CINDITIONING

Cab Version	Air conditioning is standard. Refer to New Holland for operation and filter information.
-------------	--

TRANSMISSION

Clutch	Dry 11" double plate, with separate controls: pedal operation for gearbox, traction clutch.
Gears	8 x 8 Synchro Command (platform models). 16 x 16 Synchro (cab models).
Steering	Hydrostatic control, independent circuit. Paper oil filter with replaceable cartridge. Tilt steering.

MACHINE SPECIFICATIONS

ELECTRICAL SYSTEM

Voltage 12V
Alternator 45Amp
Battery 12V capacity 88 Ah, sealed, maintenance-free.

LIGHTS

Two asymmetrical front headlamps using 40/45 W bulbs.
Two asymmetrical front headlamps using low halogen bulbs.
Two front light clusters including: side lights, directional indicator.
Two rear light clusters including: side lights, directional indicator, brake light, number plate light. Red rear reflectors.

INSTRUMENTS & ACCESSORIES

Multiple-function instrument panel, 7-pin 8 A DIN power socket, 25 A power socket, Thermo-start, and flashing hazard warning light.

CLEANING PATH 72 inches

TRANSPORT SPEED 2-8 mph

SCRUB SPEED 2-4 mph (refer to New Holland manual for proper gear selection)

TURNING RADIUS 127.6 inches

AISLE WIDTH FOR U-TURNS 11.5 feet

SOLUTION TANKS Two (2) 100 gallon capacity each, stainless steel construction, crossover lines (hoses) allows filling from either side, clean-out doors and oversize fill openings are standard.

RECOVERY TANK One (1) 210 gallon capacity, stainless steel construction, equipped with automatic vacuum shut-off float.

VACUUM SYSTEM Power provided by a regenerative air turbine, V-belt driven.

SCRUB BRUSHES Four (4) 18-inch diameter, disc type.
Brushes are mounted to a 3/8" steel frame and are readily accessible. Hydraulic cylinder raises and lowers brush assembly off ground level for travel and storage. Scrub brush discs are gimbal-mounted to follow irregular floor contours.
One-piece or sectional brushes are available.

TIRES Front: Implement Tread (2) 6.50 - 16
Rear: Tuff Tires (2) 13.6 - 28

SQUEEGEE ASSEMBLY Rear: Para-Bolic 80-inch (203.2 cm) break-away with no-tool squeegee replacement.
Side: 26 in (66 cm) Easy Change

OPTIONAL BRUSHES Bassine Amergrit
Supergrit Soft Nylon
Straight wire Amerfil (.025)
Nylon Amerfil (.040)
Amerfil & wire (one-piece only)

MACHINE DIMENSIONS

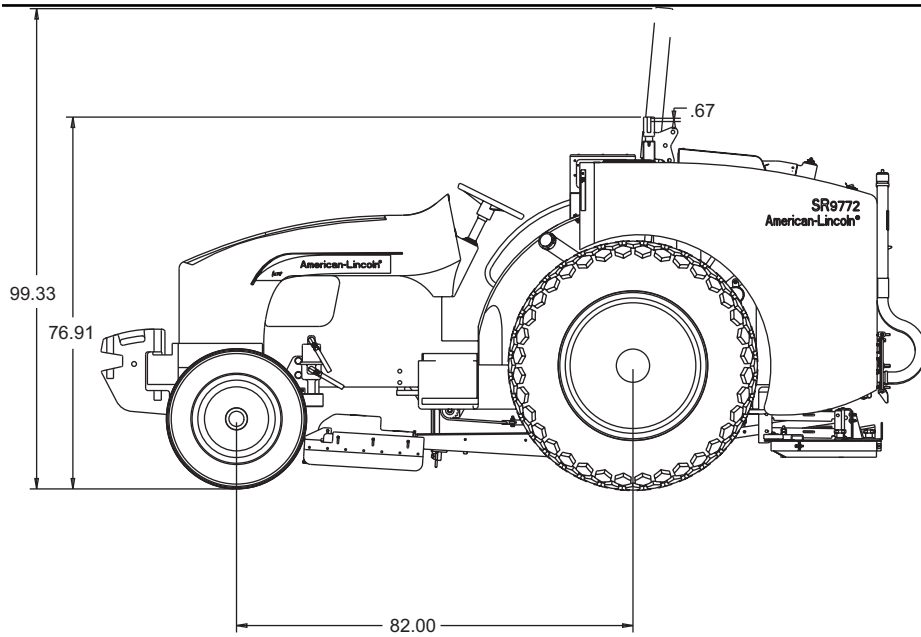

PLATFORM MODEL (SIDE VIEW)

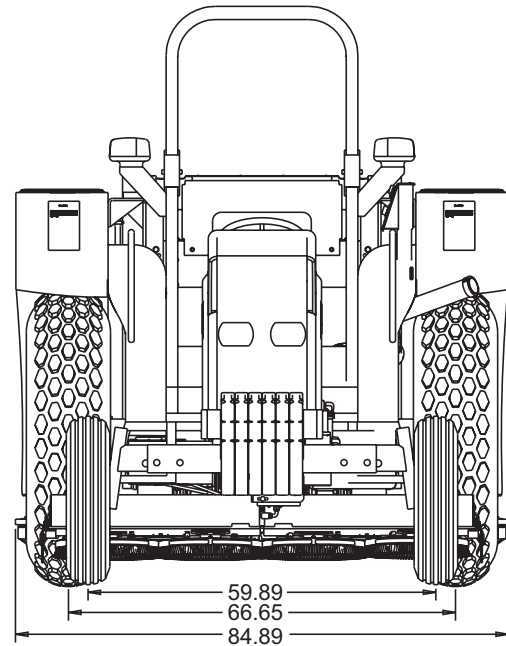

PLATFORM MODEL (REAR VIEW)

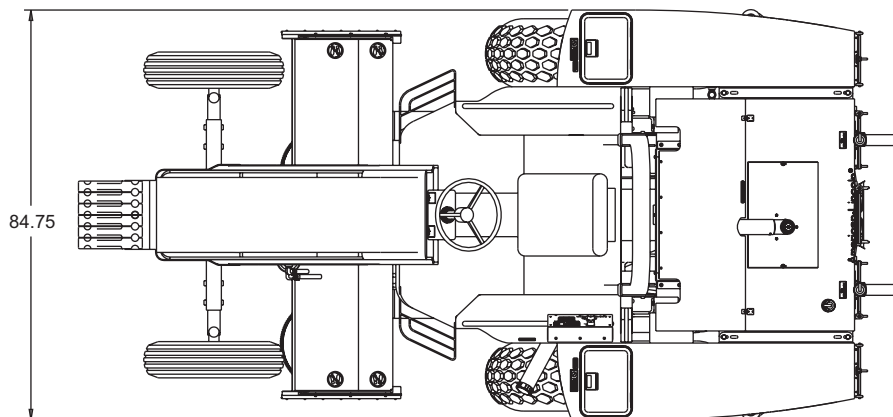

PLATFORM MODEL (TOP VIEW)

c0976/1202

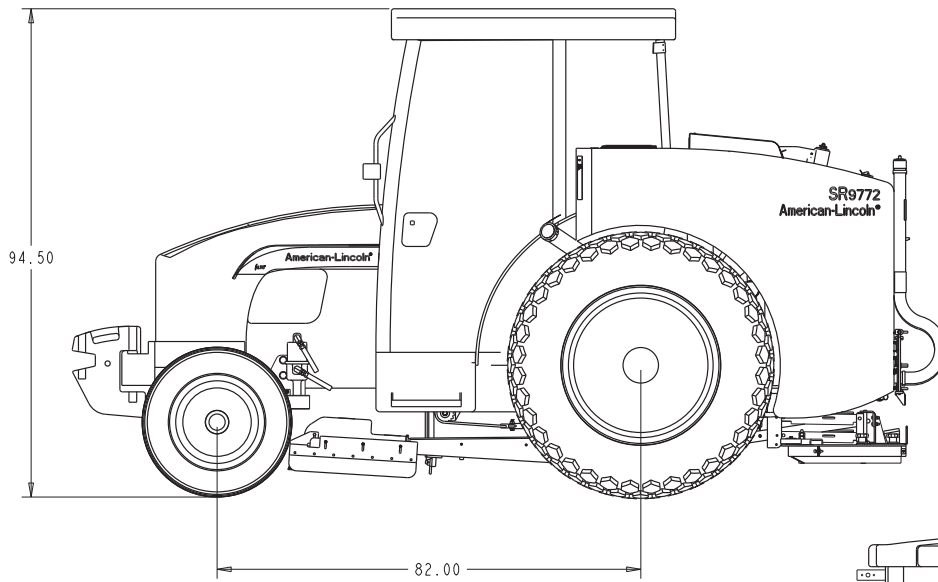

CAB MODEL (SIDE VIEW)

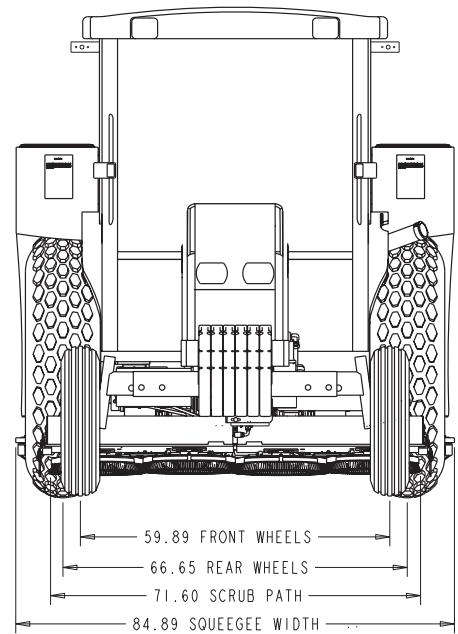

CAB MODEL (REAR VIEW)

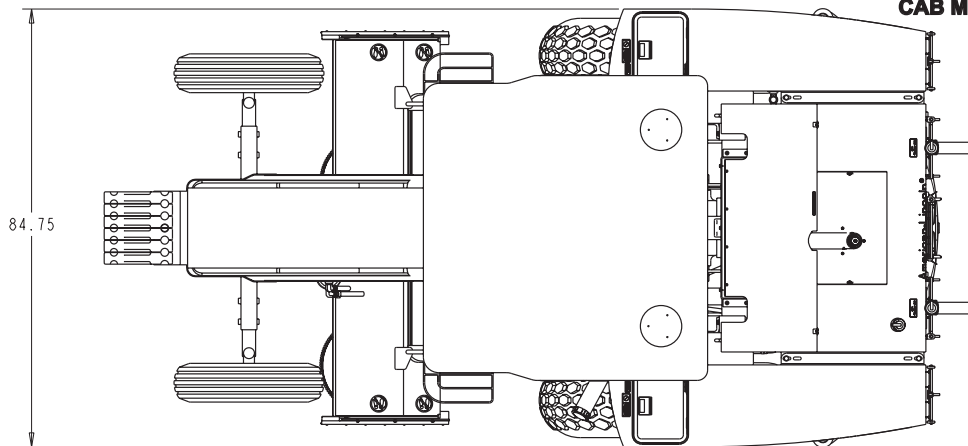

CAB MODEL (TOP VIEW)

SAFETY PRECAUTIONS

FOR SAFETY, OBSERVE THE FOLLOWING WARNINGS. FAILURE TO COMPLY MAY CREATE A SERIOUS RISK OF INJURY TO YOU AND OTHERS. THIS MACHINE SHOULD NOT BE USED IN HAZARDOUS LOCATIONS, INCLUDING AREAS OF VOLATILE DUST OR VAPOR CONCENTRATIONS.

READ THE MANUAL CAREFULLY. UNDERSTAND WHEN THESE CONDITIONS CAN EXIST; THEN TAKE NECESSARY STEPS TO TRAIN PERSONNEL WHO WILL OPERATE THIS MACHINE. FOR THE SAFE OPERATION OF THIS MACHINE, READ AND UNDERSTAND ALL WARNINGS, CAUTIONS AND NOTES.

THE FOLLOWING STATEMENTS ARE USED THROUGHOUT THIS MANUAL AS INDICATED IN THEIR DESCRIPTIONS:

DANGER - To warn of immediate hazards which will result in severe personal injury or death.

WARNING - To warn of hazards or unsafe practices which could result in severe personal injury or death.

CAUTION - To warn of hazards or unsafe practices which could result in minor personal injury.

ATTENTION - To warn of unsafe practices which could result in extensive equipment damage.

NOTE - To give important information or to warn of unsafe practices which could result in equipment damage.

⚠ WARNING

Machines can ignite flammable materials and vapors. Do not use with or near flammables such as gasoline, grain dust, solvents, and thinners.

⚠ WARNING

Improper use of heavy machinery can cause personal injury.

⚠ WARNING

Operate only when lids, doors, and access panels are securely closed.

⚠ WARNING

Use care when reversing machine in confined area.

⚠ WARNING

When servicing the machine, disconnect the batteries first to prevent possible injury.

⚠ WARNING

When working on the machine, empty hopper, remove batteries, clear area of people and obstructions, use additional people and proper procedures when lifting the machine.

⚠ WARNING

Always empty the hopper and disconnect the battery before doing maintenance.

⚠ WARNING

You must have training in the operation of this machine before using it. READ THE INSTRUCTION BOOK.

⚠ WARNING

Do not operate this machine unless it is completely assembled.

⚠ WARNING

Do not use this machine as a step or furniture.

⚠ WARNING

Stop and leave this machine on a level surface. When you stop the machine, put the power switch in the "OFF" position and engage the Parking Brake.

WARNING

To prevent injury and damage to the machine, do not lift the machine or move it to an edge of a stair or loading dock.

WARNING

Lead acid batteries generate gases which can cause an explosion. Keep sparks and flames away from batteries. NO SMOKING. Charge batteries only in areas with good ventilation.

WARNING

Always wear eye protection and protective clothing when working near batteries. Remove all jewelry. Do not put tools or other metal objects across the battery terminals or across the tops of batteries.

WARNING

Maintenance and repairs must be done by authorized personnel only. Tighten all fasteners. Maintain adjustments according to the specifications given in the service manual for the machine. Keep the electrical parts of the machine dry. For storage, keep the machine in a building.

WARNING

Make sure all labels, decals, warnings, cautions and instructions are fastened to the machine. Purchase new labels and decals from American-Lincoln.

WARNING

The operator must exhibit extreme caution when negotiating, turning, and traveling across grades or ramps. Start, stop, change direction, travel and brake smoothly. Slow down when turning.

WARNING

Avoid uneven surfaces and loose materials. Watch for obstructions, especially overhead.

WARNING

Operate only from the designated operator's position. Stay inside the body of the machine. Keep hands and feet on the designated controls. Always operate in well lighted areas.

WARNING

Do not carry passengers on the machine. Set the Parking Brake when leaving the machine. Chock (block) the wheels if the machine is parked on a grade (ramp), or is being prepared for Maintenance.

WARNING

Never leave the operator's compartment with engine running.

WARNING

Report damage or faulty operation immediately. Do not operate the machine until repairs have been completed. Maintenance and repairs must be done by authorized personnel only.

WARNING

To maintain the stability of this machine in normal operation, the overhead guard, counterweights, roller bumper guards, or any similar equipment installed by the manufacturer as original equipment should never be removed.

If it becomes necessary to remove such equipment for repair or maintenance, this equipment must be reinstalled before the machine is placed back into operation.

WARNING

Electrical hazard. Shocks can cause serious personal injury. Unplug the battery before cleaning or servicing.

To avoid possible injury or property damage, read the Operator's Manual before servicing the machine.

Maintenance and repair must be done by authorized personnel.

WARNING

Disconnecting the battery connector with the key switch in the "I" position will cause sparks that could ignite explosive hydrogen gas generated by the batteries. To prevent serious injury or possible property damage, turn Key Switch to "O" position before disconnecting the battery cable from the machine for charging or service.

MACHINE INFORMATION/PREPARATION

TOWING THE SCRUBBER

NOTE: The scrubber must only be towed for short distances. For example, from inside a building to the outside. It must never be towed for long distances on the road in heavy traffic.

NOTE: To transport the scrubber, load it, complete with its four tires, onto a truck.

Should it be necessary to tow the scrubber, use a strong chain. Tow the scrubber from the rear using only the drawbar, the rear tow-hitch or three-point linkage. Tow the scrubber from the front using the tow-hitch fitted to the front support or ballast. **THE SCRUBBER MUST BE TOWED WITH A DRIVER ON BOARD TO STEER AND STOP THE SCRUBBER WHEN NECESSARY.**

To avoid damaging the transmission or other components which turn but are not lubricated during towing, observe the following:

1. Only tow for short distances
2. Do not exceed 5 mph (8 km/h)
3. If possible, run the engine to lubricate the power steering components
4. Position the gear and range levers in neutral

CAUTION

Never use ropes or cables to tow the scrubber.
These may slip or break, presenting the risk of serious injury.

CAUTION

Never exceed 5 mph (8 km/h) when towing.
Effort to control steering is much greater and response much slower.

LOADING THE SCRUBBER ON A TRANSPORTER

Load the scrubber with all four wheels on the truck platform or flatbed trailer.

Secure the scrubber to the transporter with suitable chains.

Secure the front of the scrubber using the towing hitch; secure the rear using the tow bar or tow bar supports.

WARNING

Do not hook or connect chains around the front axle transmission shaft, power steering cylinders, front axle, or other parts of the scrubber that could be damaged by the chains or excessive strain during transport.



MACHINE PREPARATION

YOUR AMERICAN-LINCOLN SR9772 HAS BEEN SHIPPED COMPLETE, BUT DO NOT ATTEMPT TO OPERATE WITHOUT READING THE FOLLOWING INSTRUCTIONS:

1. Fill tank with diesel fuel only

WARNING

Never fill fuel tank while the engine is running.

2. Check engine crankcase oil level. Although properly lubricated at factory, check before starting engine. No special break-in oil is used and recommended number of operating hours before the initial oil change is 50 hours. See lubrication and maintenance section of the New Holland manual.
3. Check radiator coolant level. Permanent type antifreeze is added at the factory to provide protection to approximately -35°F. To retain this protection level, always add ½ part water to ½ part anti-freeze.
4. In addition to regular service operations listed, the following items should be checked every 10 hours or daily during the first 50 hours of operation.

- Engine Oil Level
- Rear Axle Oil Level (at turbine cover access)
- Rear Wheel Nuts for Tightness

NEW HOLLAND TN60 TRACTOR POWER UNIT

The American-Lincoln SR9772 utilizes a NEW HOLLAND TN60 as the power unit. The power unit provides hydraulic power for the brush drive, squeegee, solution vacuum, brush position and squeegee position functions.

This manual includes some pertinent NEW HOLLAND Operator's Manual information for the SR9772. Consult the NEW HOLLAND TN60 Operator's Manual for all tractor maintenance, service and other detailed tractor-related information. Parts for the TN60 power unit are available from your local NEW HOLLAND Dealer.

SCRUBBER OPERATION

CHECKS BEFORE USING THE SCRUBBER

Before using the scrubber, make sure you are familiar with the position and function of all controls. Ensure the maintenance and lubrication operations described in the NEW HOLLAND manual have been carried out, followed by a visual inspection of the outside of the scrubber. Give particular attention to the following:

1. Check the air filter and levels on the oil, coolant, hydraulic fluid and fuel.
2. Signs of leaks or damaged components connected to pressure tubes, sleeves and connectors.
3. Signs of cracking on the fanbelt.
4. Accumulation of foreign matter or leaks around the engine and hydraulic pump and related hoses.
5. Loose fasteners.

Always complete any necessary repairs before using the scrubber.

SAFETY COVERS

The scrubber is fitted with covers designed for the personal safety of the operator and others when in use. The BONNET covers the moving parts of the engine and must be closed before starting. The fan has COVERS on both the left and right sides.

CAUTION

Before starting the engine or using the scrubber, always make sure all safety covers, panels and access doors are securely closed.

Before starting the engine or moving the scrubber, follow these instructions:

1. Do not start or operate the scrubber in an enclosed area.
2. Before starting the engine, make sure all controls are in neutral and the parking brake is set.
3. Operate controls from driver's position only.
4. Stop engine before performing any service or maintenance operations.
5. Use the steps provided for entering and exiting the scrubber.
6. When driving on roads, indicate all intentions to stop, turn or slow down; use appropriate warning devices to indicate a slow-moving vehicle.

CAUTION

When SHIFTING from one range to another, forward to reverse, or reverse to forward, the operator MUST reduce the speed (throttle) to LOW IDLE, shift range and/or gear, then increase the speed (throttle).

STARTING THE ENGINE

1. If the scrubber has not been used for some time, or is being started for the first time in low outside temperature conditions, operate the fuel pump starting lever approximately 20 times.
2. Press down the clutch pedal, place the shuttle control lever in neutral to close the starting safety device switch.
3. Move the throttle lever to approximately the halfway position.
4. Turn the starter key and release as soon as the engine starts.

STARTING IN LOW OUTSIDE TEMPERATURES

When the outside temperature is low and the engine cold, cover the radiator before starting so the engine coolant can quickly reach the correct temperature, then remove the cover. To avoid running down the battery, any single attempt to start the engine should last no longer than 15 seconds. If, however, the engine fires but does not start, continue attempt for up to 30 seconds. Wait at least one minute between each attempt to start the engine. To avoid excessive depletion of battery, make no more than six attempts at starting.

STARTER KEY SWITCH

The following three positions appear on this switch:

- A -No power supply to any of the circuits (key can be removed); engine stops - injection shutoff activates automatically.
- B -Standby for engine start-up; indicator and control instruments ON.
- C -Engine start-up (when released, key automatically returns to position B).

STARTING WITH THE THERMOSTART

Carry out pre-start operations as previously described; turn starter switch key to position B (stand-by); turn on the thermostart by pressing pushbutton and hold for 25 seconds; move starter switch key to position C while holding down the thermostart button until engine starts. Once the engine has started, release both the key and thermostart button. If after two or three attempts the engine has not started and black smoke is coming from the exhaust, start engine without using the thermostart.

CAUTION

When starting the engine after an extended period of non-use, avoid using the hydraulic system immediately since all moving parts will require lubrication before they are subjected to full load. Especially when the outside temperature approaches 0° C (32° F), run the engine at 1300-1500 rpm for approximately five minutes to heat the rear transmission oil to working temperature.

CAUTION

If any warning lights illuminate to signal a fault, check and repair the faulty part. If the warning light continues to signal a fault, have the scrubber checked by your NEW HOLLAND dealer.

CAUTION

When the outside temperature is below 0° C, in order to prevent separation of the paraffin components in the diesel fuel which leads to a reduction in fluidity and subsequent fuel supply problems, mix the diesel fuel with antifreeze (or similar product) in the proportions described on the container. Put the antifreeze in the tank first, followed by the fuel. The antifreeze will ensure there is optimum fuel supply to the engine without reducing performance (up to -20° C/-68° F). The diesel must be mixed with the antifreeze before any sign of paraffin separation - adding it later will have no effect on the engine if the cold has already caused it to stop running or prevented it from starting.

TO DRIVE MACHINE (FOR TRANSPORT)

Follow these steps to drive (transport) the machine to the area to be cleaned.

1. Be sure the scrub brushes and the squeegee are in the "up" position with all other controls in the "OFF" position.
2. Release the parking brake.
3. Depress the clutch and move the gear and range levers to desired positions, slowly release clutch while depressing accelerator.
4. To stop, reduce speed, depress clutch and apply brakes. When scrubber is stationary, reduce to low idle, move range and gearshift levers into neutral, release the clutch and set the parking brake.

CAUTION

When SHIFTING from one range to another, forward to reverse, or reverse to forward, the operator MUST reduce the speed (throttle) to LOW IDLE, shift range and/or gear, then increase the speed (throttle).

THE SCRUBBING SYSTEMS

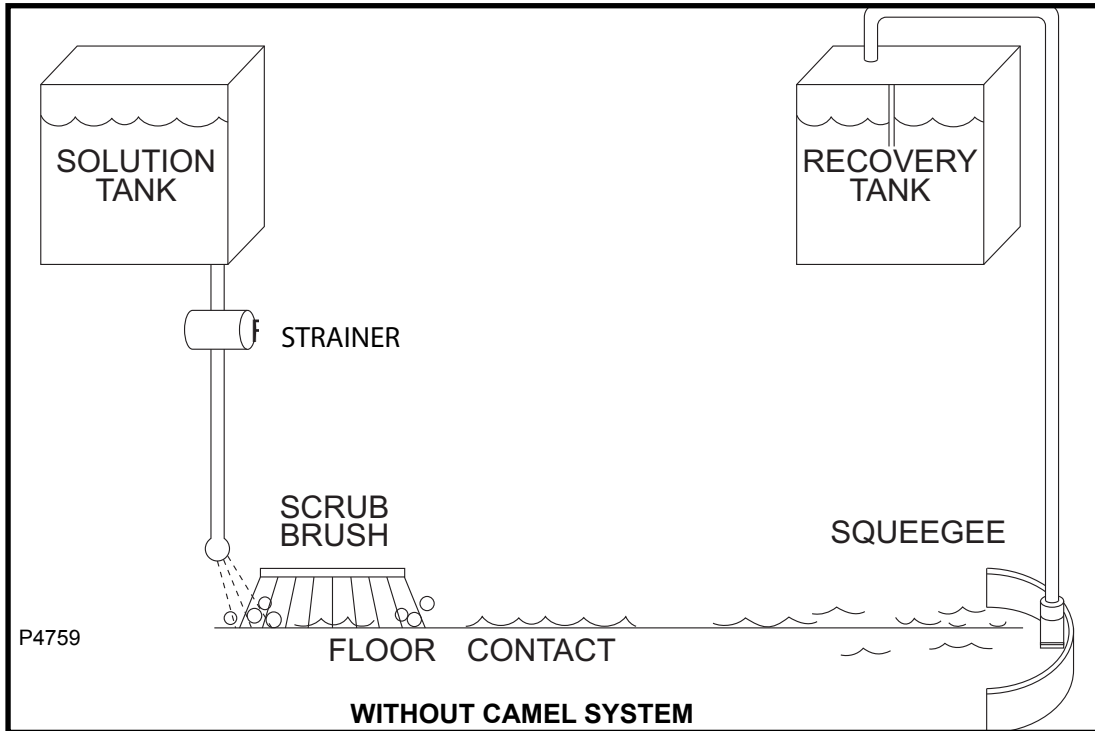

HOW IT WORKS (Without Camel System)

During the scrubbing process, a solution of detergent and water from the solution tanks is fed through the solution lines where it is disbursed to the floor through the four scrubbing brushes that aggressively work to dislodge dirt and grime.

As the machine moves forward, the solution vacuum system lifts dirty water and debris from floor surface, through the squeegee tools and a recovery tank air/water separation system. A float switch in the tank activates an indicator light on the control panel when the water level in the tank becomes too high. Debris and sludge settle to the bottom of the recovery tank.

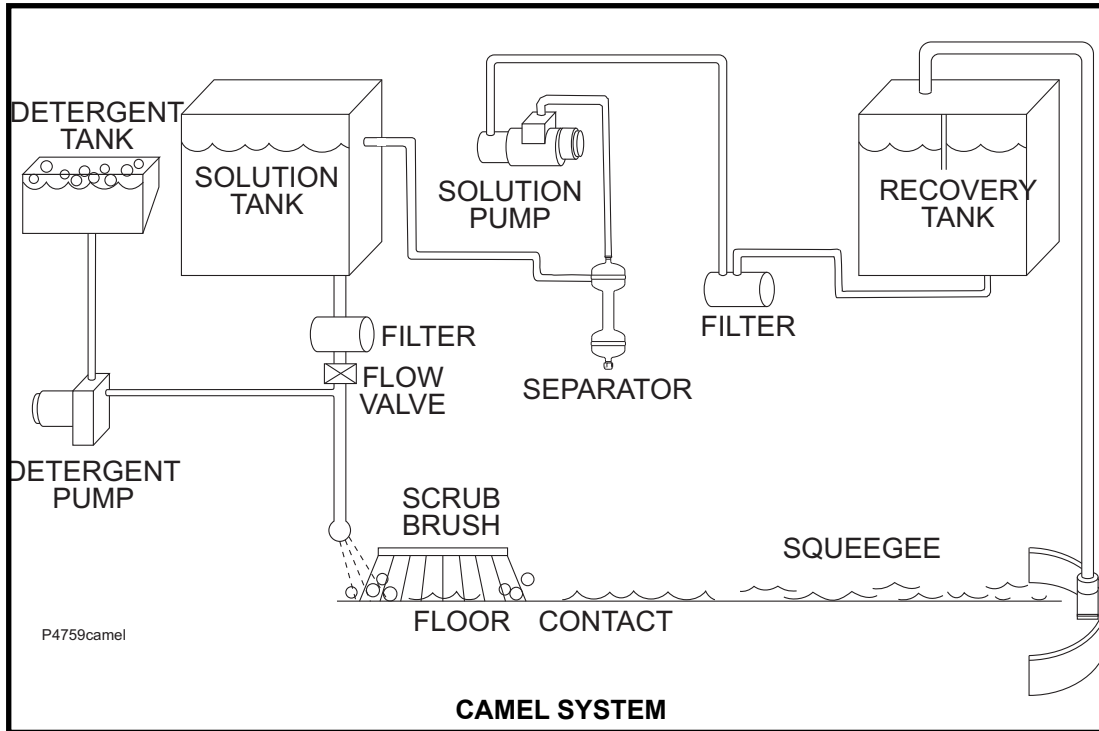

HOW IT WORKS (with Camel System)

During the scrubbing process, filtered water from the solution tank is fed through the solution lines where it combines with the detergent from the metering pumps. This mixture is then fed to the floor where four disc scrubbing brushes aggressively work to dislodge dirt and grime.

After scrubbing, the used solution is vacuumed from the floor and discharged into the containment chamber of the recovery tank. Once there, a system of baffles helps to clarify the solution on its way to the pumping chamber of the recovery tank. At intervals, a system of sensors activates the recycling pump which sends filtered solution from the pumping chamber on its way to the centrifugal separator which further aids clarifying of the solution for re-use. In the separator, solids are removed and purged into the containment chamber. The solids-free solution is then fed up through the separator outlet and into the solution tank where it is ready to be mixed with fresh, metered detergent, allowing the cleaning process to continue.

OPERATING THE SCRUBBER CONTROLS

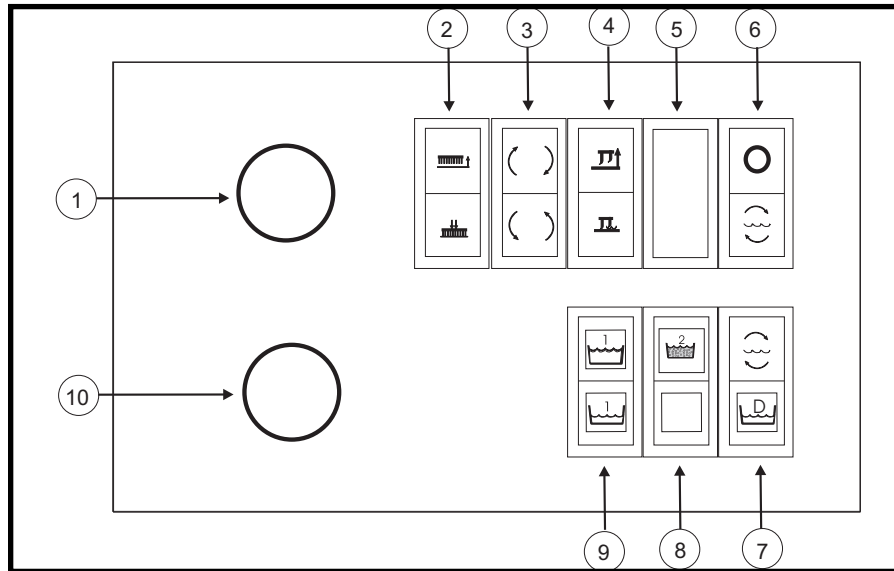

1. Solution Flow Knob - To control flow of water to scrub deck brushes once the scrub deck switch is engaged, rotate knob clockwise from the OFF position shown. Solution flow can be controlled from 0 GPM (OFF position) to 6.0 GPM in the full ON position (approximately 115° from OFF position). Solution will only flow when brushes are in scrub mode.
2. Scrub Deck Switch - Momentary contact switch, pressing the lower portion will lower the scrub deck, open the solution flow valves, and initiate brush rotation. Pressing the upper portion (up position must be HELD for 1-2 seconds) will raise the scrub deck, close the solution flow valves, and stop brush rotation.
3. Brush Rotation Switch - To control brush rotation once the scrub deck switch is engaged, utilize this two-way switch. Pressing the upper portion will result in the brushes rotating clockwise; pressing the lower portion will cause the brushes to rotate counterclockwise.
4. Squeegee/Vac Fan Switch - Pressing momentarily the contact switch will lower the squeegee and turn on the vacuum fan; pressing the upper portion will raise the squeegee and shut off the vacuum fan. IF THE MACHINE IS PLACED IN REVERSE, the squeegee automatically raises and the vacuum system shuts off. Normal operation will resume once the machine is placed in neutral or returns to its forward motion.
5. Option Switch.
6. Camel recycling switch (if equipped).
7. Warning Light (if equipped) - top light indicates recirculation system activation, bottom light indicates low detergent.
8. Warning Light - RED indicates RECOVERY TANK FULL..
9. Warning Light - high solution light indicates the solution tank is full, low solution light indicates the solution tank is low.
10. Camel Detergent Control Knob (if equipped).

OPERATING THE SCRUBBER CONTROLS



If the squeegee is in the down position and the tractor shift lever is moved into the reverse position, the squeegee will automatically raise and the solution vacuum will turn off. Once the shift lever is returned to the forward or neutral position, the squeegee will automatically lower and the solution vacuum will be turned on.



Cab Model

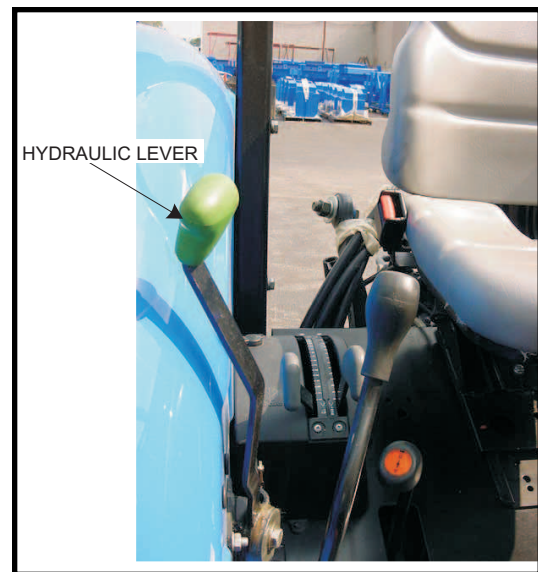

Platform Model

Prior to engaging any of the switches on the control panel, the tractor's hydraulic lever must be engaged by pulling it back.

During transport, make sure the scrub deck and squeegee are in the raised position and the tractor hydraulic lever is in the FORWARD/OFF position.

OPERATING INSTRUCTIONS

NORMAL SCRUBBING MODE

Operating Instructions:

1. Access the scrubber.
2. Check all the scrubbing system controls, verifying they are in the off position.
3. Confirm the hydraulic control lever is in the off position (all the way forward).
4. Follow the New Holland operations manual for start-up.
5. Pull the hydraulic control lever back to energize.
6. Activate the switches at the control panel to raise the scrub deck and squeegee. The scrub deck and squeegee system switches are momentary-contact switches. Press and hold the switch in upward position for 2 seconds and release. The switch will return automatically to a neutral position. Confirm the scrub deck and squeegees are in the raised position.
7. Push the hydraulic control lever forward to off/de-energize.
8. Move the scrubber to filling station by first reducing the throttle to low idle following start-up, depress clutch, select range and gear, slowly release clutch and increase throttle.

CAUTION

When SHIFTING from one range to another, forward to reverse, or reverse to forward, the operator MUST reduce the speed (throttle) to LOW IDLE, shift range and/or gear, then increase the speed (throttle).

9. To stop and shut down the machine, depress clutch and reduce throttle to low idle, move range and gear levers to neutral, apply brakes. When fully stopped, apply the parking brake and turn off engine.

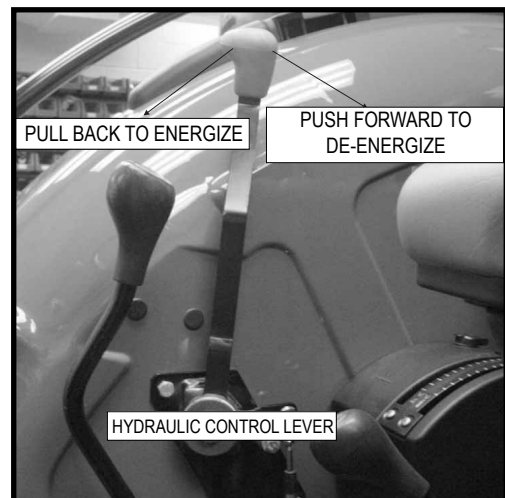
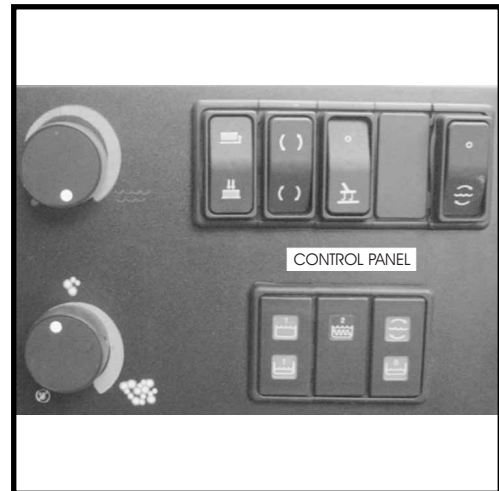

OPERATING INSTRUCTIONS

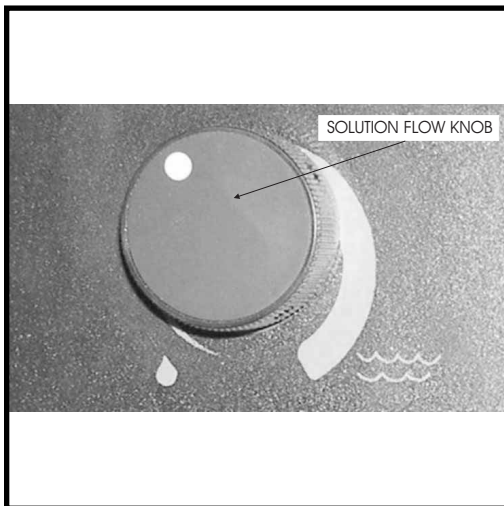
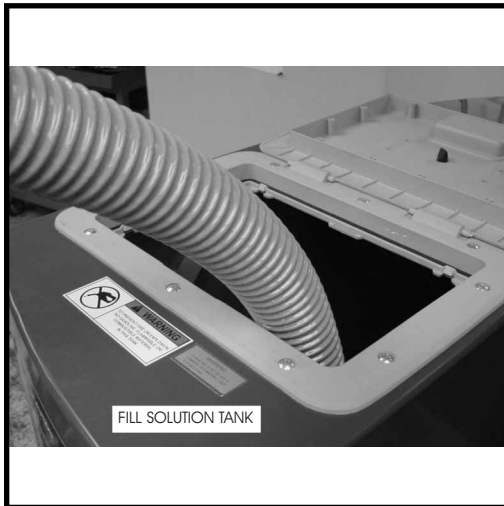

10. Open the solution tank access door on top of each tank.
 11. Fill the solution tanks with water. (The solution tanks are linked together, so you can fill through one access door. Add the recommended amount of detergent to each solution tank allowing for even chemical dispersion). (Each tank has a capacity of 100-gallons).
 12. The high solution light on the scrubber control panel will illuminate when the solution tanks are full.
 13. While the solution tanks are filling, inspect machine. (Check and clean out doors, ensuring the doors are sealed properly; inspect squeegee blades. Perform maintenance as required.)
 14. Close the solution tank access doors once the tanks are filled.
 15. Start the tractor following New Holland operating instructions, release the parking brake, and drive the scrubber to work area by first reducing the throttle to low idle following start-up, depress clutch, select range and gear, slowly release clutch and increase throttle.
 16. Stop the machine by depressing the clutch and reducing throttle to low idle, move range and gear levers to neutral, apply brakes.
 17. Depress clutch and select the appropriate gears to scrub at a speed of 2-3 mph (Low range is suggested).
 18. Activate scrub deck and squeegee switches on the scrubber control panel
 19. Pull the hydraulic control lever back to energize.
 20. Begin scrubbing.
- ⚠ CAUTION**
- When SHIFTING from one range to another, forward to reverse, or reverse to forward, the operator **MUST** reduce the speed (throttle) to LOW IDLE, shift range and/or gear, then increase the speed (throttle).
21. Adjust the water flow by turning the solution flow knob located on control panel to optimize scrubbing performance.

OPERATING INSTRUCTIONS

22. Inspect the scrub path verifying the scrub performance and solution recovery.
23. Continue scrubbing and monitoring the scrub path for maximum performance.
24. Warning lights on the scrubber control panel for low solution or high recovery will illuminate when the solution level is low or the recovery tank is full.
25. The recovery tank float ball will activate when the recovery tank is full. The vacuum airflow bypass will activate, discontinuing solution recovery.

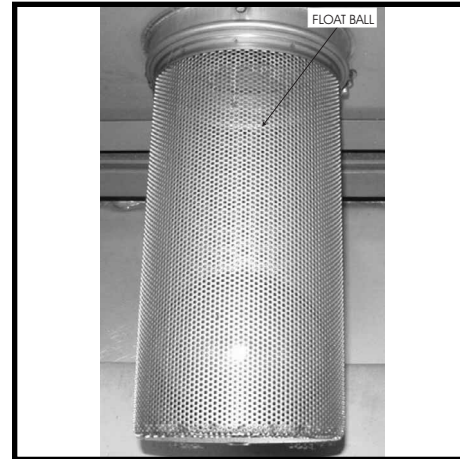
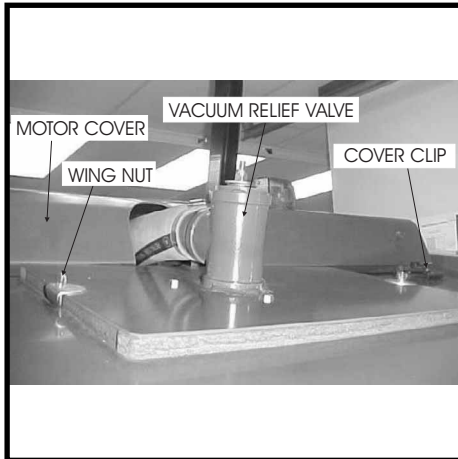

26. Activate the switch at the control panel to raise scrub deck. Press and hold the switch in upward position for 2 seconds and release, the switch will return automatically to the neutral position. Confirm that the scrub deck is in the raised position.
27. Continue moving over the scrub area until the squeegee recovers the solution.
28. Activate the switch at the control panel to raise the squeegee and turn off the vacuum system. Press and hold the switch in an upward position for 2 seconds and release, the switch will return automatically to a neutral position. Confirm that the squeegee is raised and the vacuum has stopped.
29. Move the hydraulic control lever forward to off /de-energize position.
30. Move the scrubber to the appropriate location to drain the recovery tank by first reducing the throttle to low idle, depress clutch, select range and gear, slowly release clutch and increase throttle.
31. Park the scrubber at the location by depressing the clutch and reducing throttle to low idle, move range and gear levers to neutral, apply brakes. When fully stopped, apply the parking brake and turn off engine.
32. Lower the drain hoses on rear of unit to direct recovered fluid to appropriate dump location.
33. Remove the drain plug.

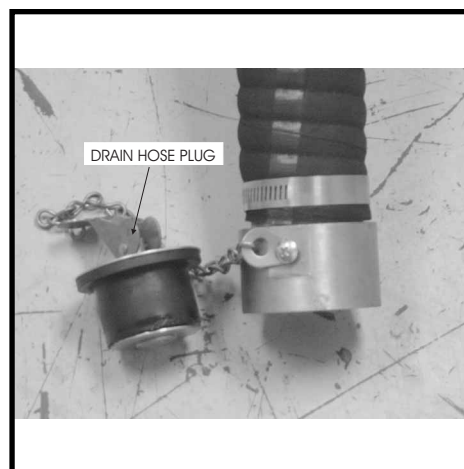
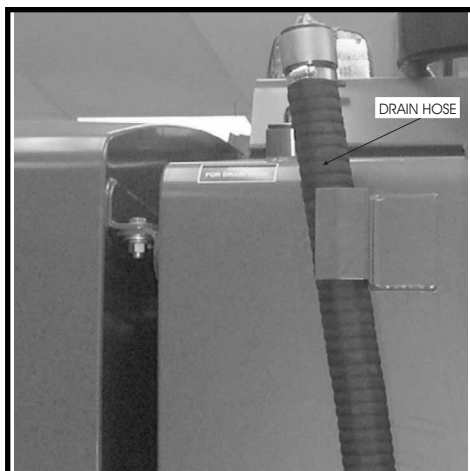

34. Once the recovery tank is drained, open the clean out doors by loosening knobs and pivoting the “t” bolts. Open door.
35. Flush out recovery tank, removing all sediment and debris from the bottom of the tank. Rinse doors and seal to remove all debris and ensure proper sealing.
36. Once the tank is clean close the door, pivot “t” bolts and tighten knobs to seal the tank.
37. Remove the plug on upper left corner of recovery tank and flush system with the hose. This removes debris in the squeegee recovery hose.



38. Replace the plug once it is clean.
39. To empty excess solution from the solution tanks loosen the knob and pivot “t” bolts.

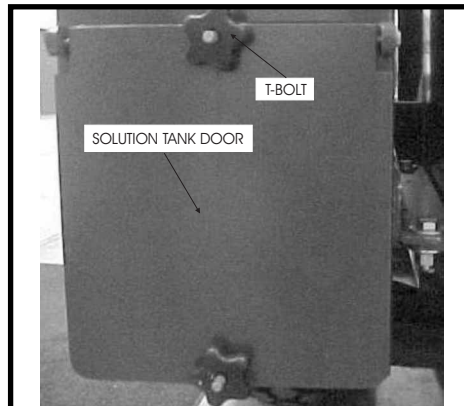

40. Flush out solution tanks removing any excess chemicals or detergent. Rinse doors and seals, close the door and pivot “t” bolt and tighten knobs.

EXTENDED SCRUBBING (CAMEL) MODE

Operating Instructions

1. Access the scrubber.
2. Check all scrub systems verifying that they are in the off position.
3. Confirm the hydraulic control lever is in off position, (all the way forward).
4. Follow the same New Holland procedure for starting tractor.
5. Pull the hydraulic control lever back to energize.
6. Activate the switches at control panel to raise scrub deck and squeegee. The scrub deck and squeegee system switches are momentary contact switches. Press and hold switch in upward position for 2 seconds and release, the switch will return automatically to a neutral position. Confirm the scrub deck and squeegees are in the raised position.
7. Push the hydraulic control lever forward to off/de-energize position.

OPERATING INSTRUCTIONS

8. Move the scrubber to filling station by first reducing the throttle to low idle following start-up, depress clutch, select range and gear, slowly release clutch and increase throttle.

CAUTION

When SHIFTING from one range to another, forward to reverse, or reverse to forward, the operator MUST reduce the speed (throttle) to LOW IDLE, shift range and/or gear, then increase the speed (throttle).

9. To stop and shut down the machine, depress clutch and reduce throttle to low idle, move range and gear levers to neutral, apply brakes. When fully stopped, apply the parking brake and turn off engine.
10. Open the solution tank access doors on top of each tank.
11. Fill the solution tanks with water. (The solution tanks are linked together, so you can fill through one access door. Add the recommended amount of detergent to each solution tank allowing for even chemical dispersion). (Each tank has a capacity of 100 gallons).
12. Fill the recovery tank to 2/3 capacity (150 gallons) with clean water.
13. Fill the detergent tank located directly in front of the right rear wheel with detergent (10 gallon capacity).

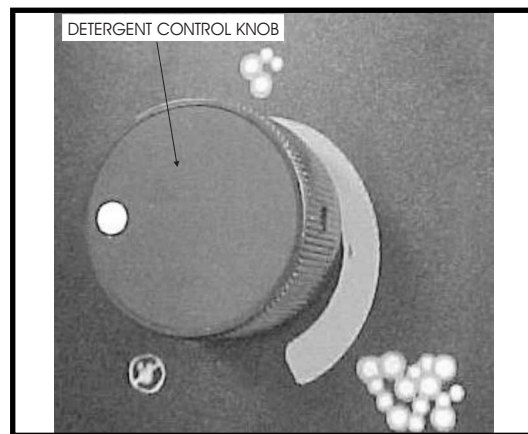

14. The high solution light on the scrubber control panel will illuminate when the solution tanks are full.
15. While solution tanks are filling, inspect the machine. Check and clean out doors, ensure the doors are sealed properly, and inspect the squeegee blades. Perform maintenance as required.
16. Close the solution tank access doors once the tanks are filled.
17. Start the scrubber following New Holland operating instructions, release the parking brake and drive the scrubber to work area by first reducing the throttle to low idle following start-up, depress clutch, select range and gear, slowly release clutch and increase throttle.
18. Stop the machine by depressing the clutch and reducing throttle to low idle, move range and gear levers to neutral, apply brakes.
19. Depress clutch and select the appropriate gears to scrub at a speed of 2-3 mph (Low range, second gear is suggested).
20. Activate scrub deck and squeegee switches on the scrubber control panel.
21. Pull the hydraulic control lever back to energize.
22. Begin scrubbing.
23. Adjust the water flow by turning the solution flow knob located on control panel to optimize scrubbing performance.
24. Activate the recycle switch on the control panel to start recycling mode. Camel System light will illuminate on the control panel, when system is operating. The switch is to remain in recycle mode position.
25. To adjust the detergent flow, turn the camel detergent control knob located on control panel to desired detergent mixture.

26. A Warning light on control panel will illuminate when the detergent tank is low on detergent.



27. NOTE: The camel system will operate automatically and intermittently. The float system in the recovery tank and the system control logic will automatically control the pumping of the water from the recovery tank into the solution tanks, once operating conditions are met.
28. If the solution tanks are full, the system will not pump water from the recovery tank to the solution tanks; the system will remain in standby mode until the solution tank capacity is available.
29. If the recovery tank is low on solution the system will not activate, and will remain in standby mode until enough solution is available to pump from the recovery tank into the solution tanks. Once the system activates, the camel system will pump the solution from the recovery tank into the solution tank, until the solution tanks if full or the recovery tank compartment in low.
30. Inspect the scrub path and verifying the scrub performance and solution recovery.
31. Continue scrubbing, monitoring the scrub path for maximum performance.
32. Warning lights on the scrubber control panel for low solution or high recovery will illuminate when the solution level is low or the recovery tank is full.
33. The recovery tank float ball will also activate when the tank is full. The vacuum airflow bypass will activate, discontinuing solution recovery.
34. Activate the switch at the control panel to raise scrub deck. Press and hold the switch in upward position for 2 seconds and release, the switch will return automatically to the neutral position. Confirm that the scrub deck is in the raised position.
35. Continue moving over the scrub area until the squeegee recovers all of the solution.
36. Activate the switch at the control panel to raise the squeegee and turn off the vacuum system. Press and hold switch in an upward position for 2 seconds and release, the switch will return automatically to a off position. Confirm the squeegee is raised and the vacuum has stopped.
37. Push the hydraulic control lever forward to off/de-energize position.
38. Move the scrubber to the appropriate location to drain the recovery tank by first reducing the throttle to low idle, depress clutch, select range and gear, slowly release clutch and increase throttle.
31. Park the scrubber at the location by depressing the clutch and reducing throttle to low idle, move range and gear levers to neutral, apply brakes. When fully stopped, apply the parking brake and turn off engine.
40. Lower drain hoses on rear of unit to direct recovered fluid to appropriate dump location.
41. Remove drain plug.
42. Once the recovery tank is drained, open the clean out doors by loosening knobs and pivoting the "t" bolts.

OPERATING INSTRUCTIONS

43. Flush out the tanks, removing all sediment and debris from tank bottoms of all three compartments. Rinse doors and seals to remove all debris and ensure proper sealing.

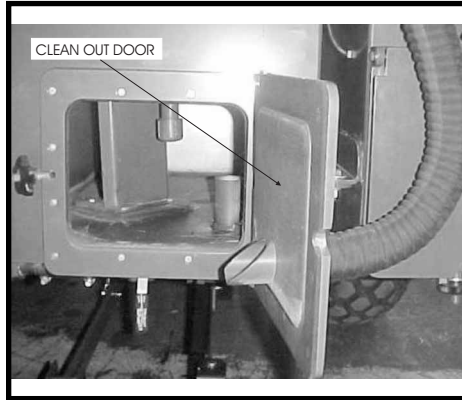

44. Once the tanks are clean close doors, pivot “t” bolts and tighten knobs to seal the tanks.
45. Remove the plug on the upper left corner of recovery tank and flush system with hose. This removes debris in the squeegee recovery system.
46. Replace the plug once it is clean.

FLOOD RECOVERY MODE (Camel System only)

Operating Instructions

1. Access the scrubber.
2. Check all the scrub systems verifying they are in the off position.
3. Confirm the hydraulic control lever is off position (all the way forward).
4. Follow the New Holland operations manual for start up.
5. Pull the hydraulic control lever back to energize.
6. The system switches are momentary contact switches. Press and hold the switch in upward position for 2 seconds and release, the switch will return automatically to a off position. Confirm the scrub deck and squeegees are in the raised position.
7. Push the hydraulic control lever forward to off/de-energize position.
8. Move the scrubber to the work area by following the throttle and range and shifting procedures.

CAUTION

When SHIFTING from one range to another, forward to reverse, or reverse to forward, the operator MUST reduce the speed (throttle) to LOW IDLE, shift range and/or gear, then increase the speed (throttle).

9. Stop the machine by following the throttle and range and shifting procedures.
10. Select the appropriate gears to scrub at a speed of 2-3 mph.
11. Activate the squeegee switch on the scrubber control panel (squeegee down, vacuum on).
12. Pull the hydraulic control lever back to energize.
13. Begin the solution recovery.
14. NOTE: The float system in the main recovery tank and the system control logic will automatically pump water from the recovery tank into the solution tank, once operating parameters are met.
15. If the solution tanks are full, the system will not pump water from the recovery tank to the solution tanks which act as secondary recovery tanks, and the system will remain in standby mode.
16. Inspect the recovery path and verify the performance.
17. The warning light on the scrubber control panel for high recovery will illuminate when the appropriate tank condition is met.
18. The recovery tank float ball will also activate when the recovery tank is full. The vacuum air by-pass will activate discontinuing solution recovery.
19. Activate the switch at control panel to raise the squeegee and turn off the vacuum system. Press and hold switch in an upward position for 2 seconds and release, the switch will return automatically to a off position. Confirm that the squeegee is raised and the vacuum has stopped.
20. Push the hydraulic control lever forward to off/de-energize position.

21. Move the scrubber to the appropriate location to drain the recovery tank by following the throttle and range and shifting procedures.
22. Park the scrubber at the location by depressing the clutch and reducing throttle to low idle, move range and gear levers to neutral, apply brakes. When fully stopped, apply the parking brake and turn off engine.
23. Lower the drain hoses on rear of unit to direct recovered fluid to appropriate dump location.
24. Remove the drain plug.
25. Once the tank is drained, open the clean out doors. By loosening knobs and pivoting the "t" bolts. Open doors.
26. Flush out the primary recovery tank, removing all sediment and debris from tank bottoms of all three compartments. Rinse off screens insuring they are free of debris, also rinse doors and seals to remove all debris, to ensure proper sealing.
27. Once the tanks are clean close the doors and pivot "t" bolts and tighten the knobs to seal the tank.
28. Remove the plug on upper left corner of recovery tank and flush the system with the hose. This removes debris in the squeegee recovery system.
29. Replace the plug once it is clean.

OPERATION ON GRADES

The machine may be operated on grades up to 8° if the surface provides adequate traction.

WARNING

Always test wet surface traction part way up or part way down sloped area, so that if slipping does occur control can be regained before reaching the bottom of the slope. Adding springs will decrease scrub brush load. Shorter brush life can be expected as the scrub brush load is increased.

POST-OPERATION INSTRUCTIONS - Perform these steps after the machine has been shut down:

- Check for string or wire tangled on scrub brushes.
- Check scrub brushes for wear or damage.
- Check squeegees for wear, damage, or adjustment.
- Drain and clean recovery tanks.
- Clean the recovery tank's screen and float.
- Check vacuum pipes and hoses for obstructions.
- Check the slash skirt for wear, damage, or adjustment.
- Check the outlet strainers in the solution tanks for contamination.
- Fill fuel tank (Diesel only)
- Check for leaks

OPERATING INSTRUCTIONS

TO CLEAN THE SOLUTION TANKS

Follow these instructions to clean the solution tanks after every scrubbing cycle:

- Inspect, remove, and clean the solution inlet filter on the bottom of the left hand and right hand tanks.
- Flush the sediment accumulations from the floor of the tanks.

TO CLEAN THE RECOVERY TANK

Follow these instructions to clean the recovery tank after every scrubbing cycle:

- Position a corner of the machine near a floor drain, check tank to make sure tank is purged.
- Open all clean-out doors. Use a hose and squeegee to remove the dirt and sludge from to bottom of the tank, clean out all three compartments.
- Remove the clean-out cap located on top of the recovery tank. Inspect and flush the pick-up tubes and squeegee hose.

HELPFUL HINTS FOR CLEANING OPERATION

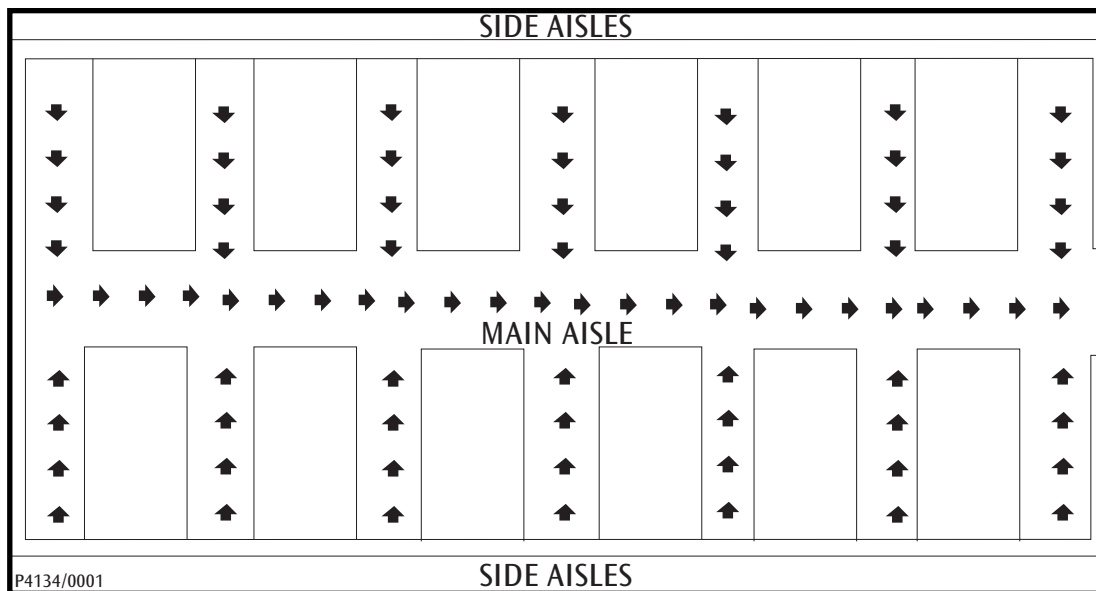

WARNING

Do not turn the steering wheel sharply when the machine is in motion. The scrubber is very responsive to movement of the steering wheel. Do not make sudden turns.

Follow these hints to get the best possible cleaning results:

- Scrub in straight paths, Do not bump posts. Do not scrape the sides of the machine
- Plan scrubbing in advance. Try to arrange long runs with minimum stopping and starting.
- Sweep heavily littered areas before scrubbing
- Allow a few inches of overlap on the scrub paths.
- Replace disc scrub brushes when bristles are worn down to 1/2"
- Replace squeegee rubbers when all usable edges have become rounded with wear, impairing the wiping action

For service assistance, consult your factory-authorized American-Lincoln dealer. For best performance, replace worn scrubbing system parts with genuine American-Lincoln parts. REFERENCE NEW HOLLAND MANUAL FOR ALL TRACTOR MAINTENANCE/SERVICE DETAILS.

EVERY 8 HOURS or DAILY Operation Checklist (Clean/adjust if necessary)

1. Fuel level
2. Engine oil level
3. Radiator coolant level and radiator core
4. Water separator/Fuel filter
5. Power steering fluid oil level
6. Scrub brushes for wear or damage
7. All flaps for wear or damage
8. Recovery tank and pick up hoses
9. Vacuum manifold (through recovery tank access door)
10. Squeegee for wear or damage

EVERY 50 HOURS (LUBRICATION AND MAINTENANCE)

11. Lubricate all grease fittings (see New Holland manual for reference)
 12. Check battery electrolyte level
 13. Check rear axle oil level
 14. Check and adjust clutch free play
 15. Check front and rear tires, lug nuts
- Perform recommended New Holland tractor maintenance (see tractor manual)

EVERY 100 HOURS

16. Lubricate squeegee casters
 17. Lubricate all moving joints (brush and squeegee lift)
 18. Lubricate head lift (chain and sprockets)
 19. Clean solution tank and filter screen
- Perform recommended New Holland tractor maintenance (see tractor manual)

EVERY 300 HOURS

20. Change engine oil and filter
 21. Change hydraulic system filter
 22. Clean engine air filter
 23. Check transmission oil level
 24. Check and adjust foot brakes
 25. Check and adjust belt tension
- Perform recommended New Holland tractor maintenance (see tractor manual)

EVERY 600 HOURS

26. Change fuel filter/separator
 27. Lubricate front wheel bearings (see tractor manual)
 28. Replace engine air filter element
- Perform recommended New Holland tractor maintenance (see tractor manual)

EVERY 1200 HOURS or EVERY YEAR

29. Change rear axle oil
 30. Change transmission oil
 31. Check, clean, and adjust fuel injectors
 32. Change power steering oil and filter
 33. Drain and flush radiator coolant system
- Perform recommended New Holland tractor maintenance (see tractor manual)

SERVICE INSTRUCTIONS

BRUSH PRESSURE AND BRUSH WEAR

Factors affecting brush wear are type of bristle, bristle, area, and load on the bristles. See your authorized distributor for the type of brush and bristle most suitable.

Brush pressure may be adjusted by adding or removing counterbalance springs. The counterbalance springs are located on the underside of the tractor foot rest.

The pressure will vary as follows:

No. of Springs	Pressure per Brush
0	353.8 lbs.
1	315 lbs.
2	291.4 lbs.
3	272 lbs.
4	252 lbs.

Adding springs will decrease scrub brush load. Shorter brush life can be expected as the scrub brush pressure is increased.

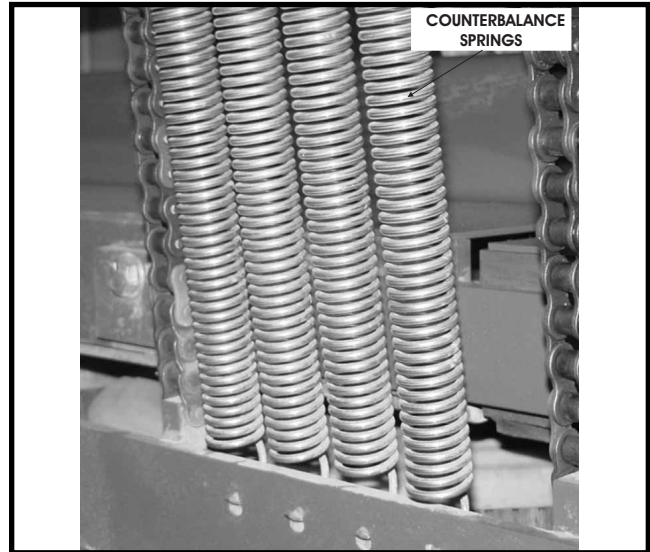

REAR SQUEEGEE

The squeegee will require service when the inner edges of the blades become round with wear, impairing the wiping action or water pickup. To service the rear squeegee use the following steps:

1. Loosen the aluminum knobs (these hold the squeegee tool to the squeegee support).
2. Remove the squeegee tool and turn upside down to service the blades or caster wheels. The squeegee blades are designed to flip over and use another unworn edge.

To service the blades:

1. Loosen the clamp bolts.
2. Loosen far enough to slip the end clamp brackets off the squeegee tool. This will allow flipping the blades or installing new blades.
3. Install blades so that outer blade is 3/16" longer than inner blades by assembling the top edge of the blade against the squeegee tool weldment.
4. Reinstall squeegee clamp band and tighten clamp bolt tight.

ADJUSTING SQUEEGEE CASTER WHEELS

Grease caster wheel zerks, casters should be greased each time the blades are serviced. Lower squeegee on a flat surface, making sure the rear squeegee blade is perpendicular to the surface. Adjust caster 3/16" above the flat surface, Lock jam nuts.

SQUEEGEE VACCUM HOSE

Check squeegee vacuum hose for wear, cracks or damage.

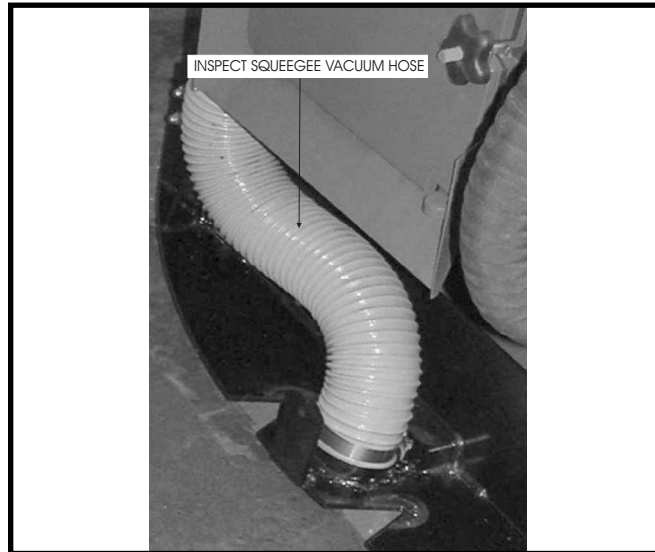

FUEL NOZZLE

Before starting the scrubber make sure that there is enough fuel in the tank. The fuel nozzle is located on the front of the scrubber to the left side under the fender. Fuel up regularly to prevent the engine stalling and interruption of cleaning cycle. Add the appropriate fuel, refer to New Holland manual.



SERVICE INSTRUCTIONS

FUSES

Fuses are easily accessible by removing the panel. Replace blown fuse with the same size fuse to prevent damage to the electrical circuit.

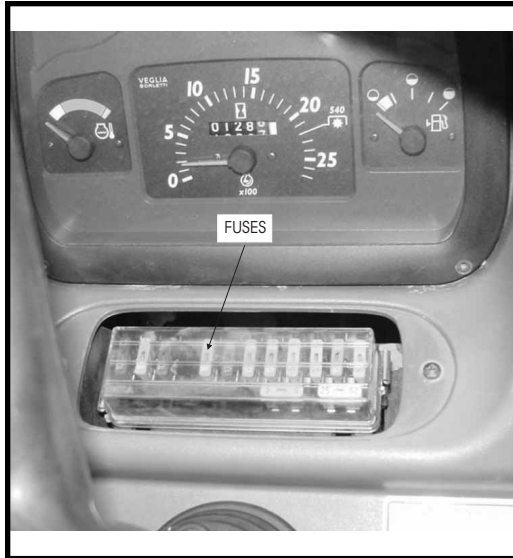

SOLUTION FEED HOSES

To check solution hoses for damage remove cover by unscrewing the nut on the side of the cover. Clean and check hoses for cracks or leaks. Replace damaged hoses to prevent loss of solution.

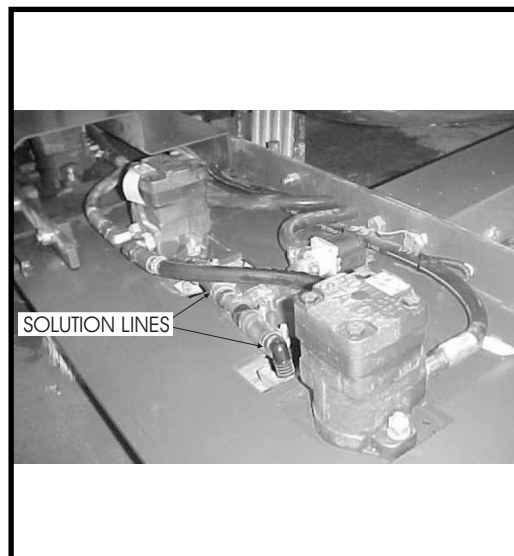
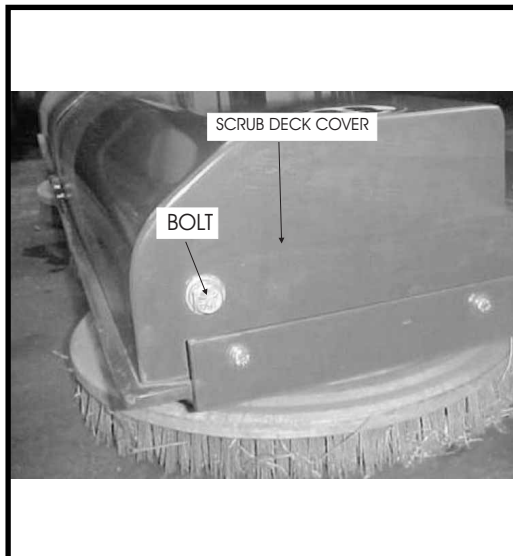

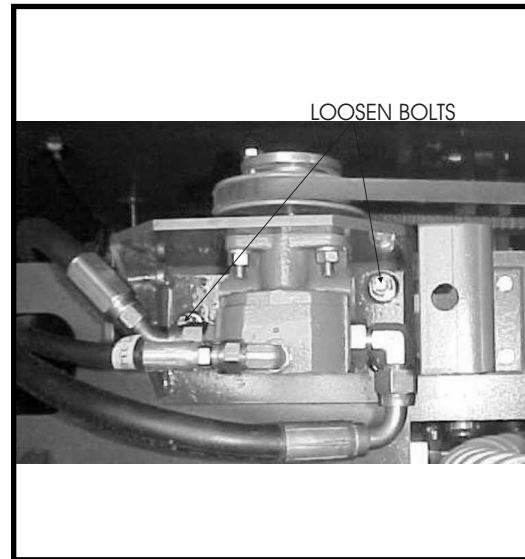
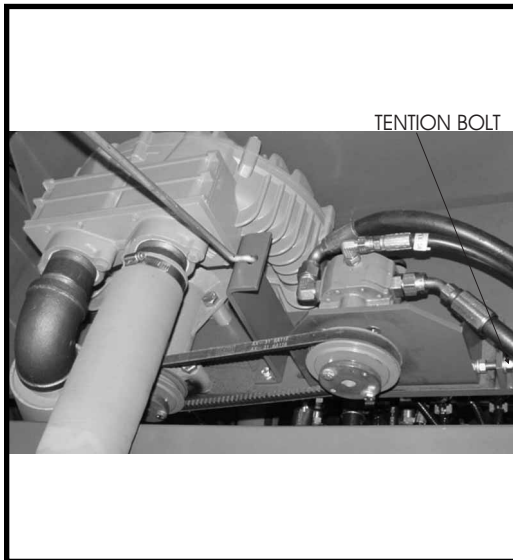

TURBINE BELT ADJUSTMENT

Do not tighten belt excessively after initial break-in. New belt may be set up tight since initial run (first hour) will “seat” the belt and give it the initial stretching under load required. Belt tension should be checked periodically thereafter. To adjust belt tension: Open turbine cover, loosen bolts, tighten adjusting nut to increase tension (proper setting is 1/2” deflection of the belt with 25 lbs. of pressure at midpoint between the two pulleys), then re-tighten bolts.

SPLASH SKIRT ADJUSTMENT

Adjust the right and left side skirts with brush wear to maintain minimal floor clearance.

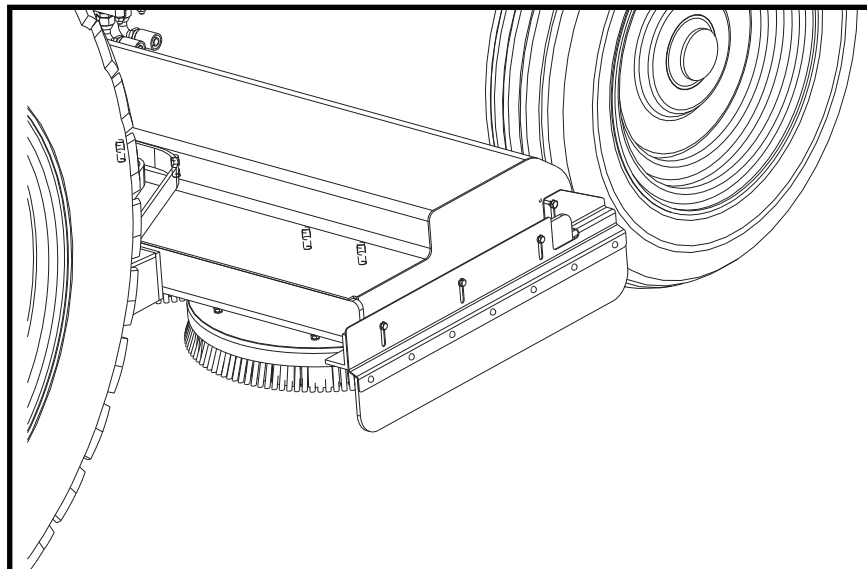

SERVICE INSTRUCTIONS

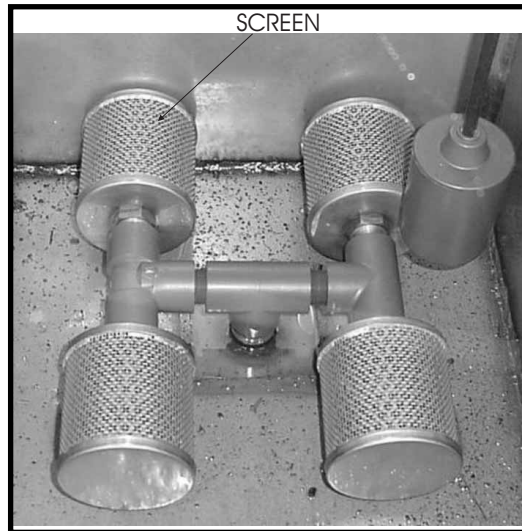
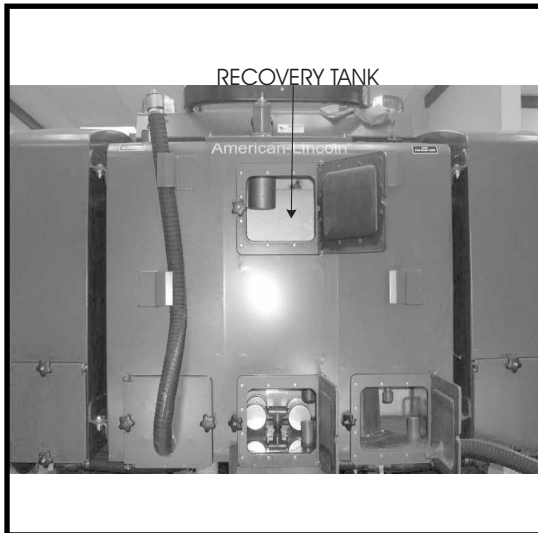

SERVICING THE RECOVERY TANK

When the tank is full (9" from top), the red indicator light is activated on the console. At a height of 8" from the top of the tank, the vacuum air flow to the squeegees will automatically shut off. On the camel system inspect, remove and clean inlet screens on the bottom of the recovery tank.

To drain:

Position the machine at desired disposal location, position hose and open drain plug.

To clean:

To remove sludge after draining, open all the drain doors, hose out tank interior to flush sludge. The float and float cage should be flushed clean. Remove clean-out cap and flush pick-up tube and squeegee hoses.

NOTE

Sludge accumulations greater than 2" will tend to clog the drain plug and drain hose.

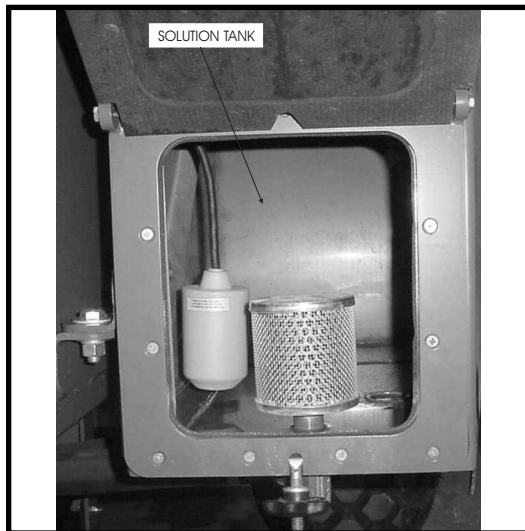

SERVICING THE SOLUTION TANK

Standard Machine:

Periodically remove and clean out the solution inlet filter from the left- and right-hand side tanks.

Camel Machine:

Sediment on the floor of each tank should be flushed periodically. Crossover hoses should be disconnected and flushed periodically.

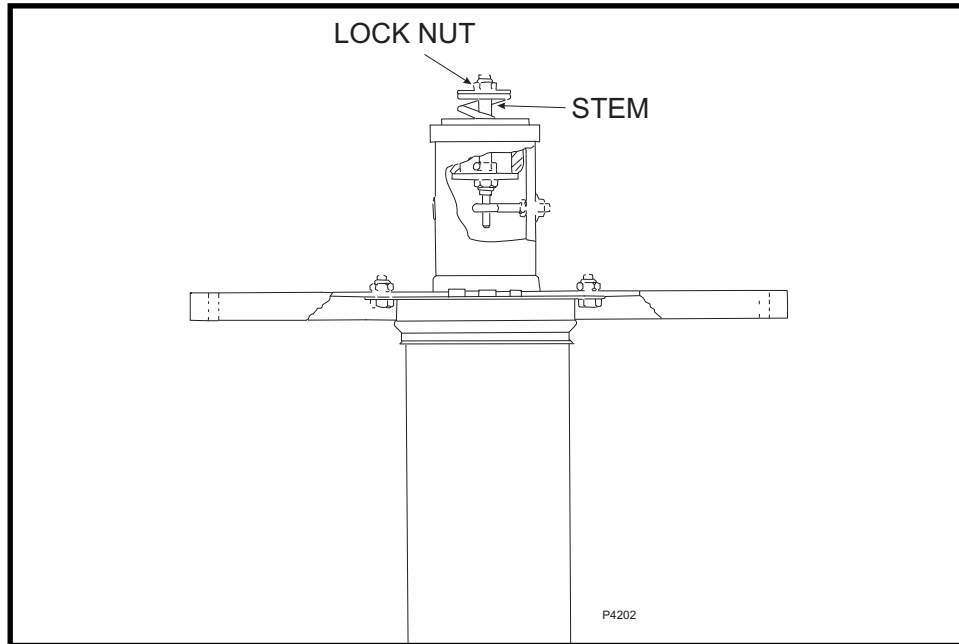

VACUUM RELIEF VALVE

The vacuum manifold inlet system is equipped with a factory-adjusted relief valve which limits the pressure produced by the solution vacuum at 90 - 95" of water.

CAUTION

Continuous operation at vacuum pressures exceeding 95" of water will cause excessive heat in the turbine resulting in turbine failure.

The relief valve is located on top of the recovery tank and is part of the air inlet system for the solution vacuum.

To check the factory setting:

1. Remove the squeegee suction hoses from the recovery tank pick-up hoses.
2. Cover inlet pipe (must be air-tight seal).
3. Run engine at 2000 rpm.
4. Place vacuum gauge on other inlet pipe and check reading.

To adjust relief valve setting:

1. Hold the stem to keep it from turning.
2. Turn the locknut clockwise to increase the setting; counterclockwise to decrease the setting.

TROUBLESHOOTING - SCRUBBING SYSTEMS

TROUBLESHOOTING - SCRUBBING SYSTEM

<u>PROBLEM</u>	<u>PROBABLE CAUSE</u>	<u>REMEDY</u>
Poor scrubbing action	<ol style="list-style-type: none"> 1. Worn scrubbing brushes 2. Incorrect method of operation 3. Wrong cleaning agent or mixture 4. Poor scrubbing distribution 5. Low engine rpm 6. Hydraulic system 7. Hydraulic Drive 	<ol style="list-style-type: none"> 1. Inspect brushes. If brushes are worn to 1/2" or less, replace all 4 brushes 2. Check scrubbing procedure, brush pressure, type of brush solution flow & cleaning chemical used. For extreme conditions double scrubbing may be necessary. 3. Use A-L recommended materials. 4. Clean out distribution tube & metering holes to brushes. Check feed hose & clean if necessary. Check valve & solution control system. 5. Check rpm. 6. See "hydraulic system" troubleshooting 7. Check motors to see if worn or damaged.
Poor solution pick up	<ol style="list-style-type: none"> 1. Clogged suction hoses or pick up tools 2. Loose connections between suction hose & squeegee or between manifold & turbine inlet. 3. Vacuum turbine not operating 4. Vacuum float shut off 5. Drain plug missing or drain door leakage or not properly closed. 	<ol style="list-style-type: none"> 1. Disconnect suction hose from squeegee, flush squeegee & hoses. 2. Check all hose connections for looseness or damage. 3. Check all air discharge at turbine muffler. Check for slipping or broken drive belt. 4. Excessive solution recovery, drain tank. Excessive foam build up, change cleaning chemical mixture. 5. Close, repair, or replace.
Splash control	<ol style="list-style-type: none"> 1. Brush drive splash skirts - more than 1/8" from floor 2. Splash skirts worn 3. Too much solution being applied 	<ol style="list-style-type: none"> 1. Readjust to 1/8" clearance. 2. Replace & adjust. 3. Readjust solution flow.
Brush wear	<ol style="list-style-type: none"> 1. Lift chain(s) not adjusted properly. 2. Brush housing sections binding with linkage 3. Counterbalance spring bias pressure. 	<ol style="list-style-type: none"> 1. Inspect for slack with brushes down. Adjust as necessary. 2. Check and repair. 3. Readjust or replace springs for required pressure.

TROUBLESHOOTING - HYDRAULIC SYSTEM

<u>PROBLEM</u>	<u>PROBABLE CAUSE</u>	<u>REMEDY</u>
Brushes not turning or turning slowly (196 rpm at 1450 engine rpm)	<ol style="list-style-type: none"> 1. Faulty relief valve(s) 2. Hydraulic system not engaged 3. Worn drive motor 4. Incorrect switch position 5. Worn gear pump 6. Low engine rpm 7. Low sump oil level 8. Clogged pump inlet filter 9. Electrical Power 	<ol style="list-style-type: none"> 1. Check relief valve pressure, should be 2500 psi. 2. Engage hydraulics 3.. Repair or replace 4. Repair or replace 5. Repair or replace 6. Check rpm. 7. Check and fill 8. Replace 9. Check panel plus connection to scrubber
Brushes not lifting	<ol style="list-style-type: none"> 1. Cylinder piston leakage 2. Incorrect switch position 3. Worn gear pump 4. Hydraulic system not engaged 	<ol style="list-style-type: none"> 1. Repair or replace 2. Actuate system 3. Repair or replace 4. Engage hydraulics
Brushes not lowering	<ol style="list-style-type: none"> 1. No power to control panel 	<ol style="list-style-type: none"> 1. Check electrical connection and fuse.

TROUBLESHOOTING SQUEEGEE CONTROL SYSTEM

<u>PROBLEM</u>	<u>PROBABLE CAUSE</u>	<u>REMEDY</u>
Failure to lift with shift lever in reverse (control lever up)	<ol style="list-style-type: none"> 1. No power to control panel 2. Switch contact 	<ol style="list-style-type: none"> 1. Check electrical connection and fuse. 2. Adjust contact location.
Failure to lower with shift lever in forward gears (control lever down)	<ol style="list-style-type: none"> 1. No power to control panel 2. Incorrect switch position 	<ol style="list-style-type: none"> 1. Check electrical connection and fuse. 2. Actuate system.

TROUBLESHOOTING - CAMEL RECYCLING PUMP

TROUBLESHOOTING CHART - CAMEL RECYCLING PUMP

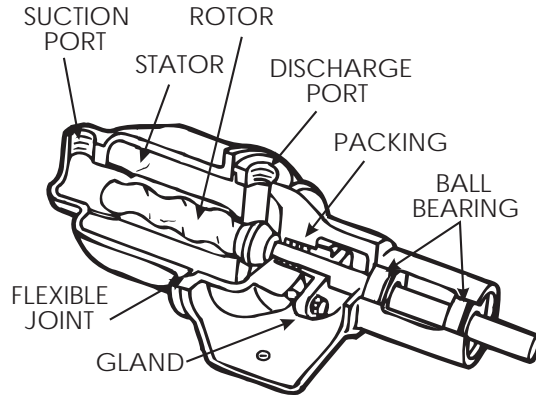

<u>PROBLEM</u>	<u>PROBABLE CAUSE</u>	<u>REMEDY</u>
Failure to pump	<ol style="list-style-type: none"> 1. Coupling slip 2. Stator torn 3. Wrong rotation 4. Threads in rotor or on shaft stripped 5. Excessive suction lift or vacuum 	<ol style="list-style-type: none"> 1. Tighten set screw on coupling 2. Possible excessive pressure. Replace stator, check pressure at discharge port. Maximum pressure is 40 psi 3. Check for clockwise rotation when facing shaft 4. Replace part, check for proper rotation 5. Check for obstructions inside intake line
Pump Overhauls	<ol style="list-style-type: none"> 1. Excessive discharge pressure 2. Bearings worn 3. Broken flexible joints 4. Insufficient mounting 	<ol style="list-style-type: none"> 1. Check discharge pressure. Maximum pressure is 40 psi. Check for obstructions at discharge port. 2. Replace parts, check alignment and pressure at discharge ports (40 psi) 3. Replace part, check pressure at discharge port 4. Check mounting to be sure pump is securely mounted to base
Shaft leakage	<ol style="list-style-type: none"> 1. Leakage at startup 2. Persistent leakage 	<ol style="list-style-type: none"> 1. Adjust packing 2. Packing rings and/or shaft keys may be worn. Inspect and replace if necessary
Pump will not prime	<ol style="list-style-type: none"> 1. Air leak in suction side 	<ol style="list-style-type: none"> 1. Check all pipe connections at suction side
Noise during operation	<ol style="list-style-type: none"> 1. Starved suction 2. Bearings worn 3. Broken flex joint 4. Insufficient mounting 	<ol style="list-style-type: none"> 1. Check fluid supply for obstructions in supply line 2. Replace parts as required. Check alignment and pressure at discharge port (maximum pressure of 40 psi) 3. Replace part and check pressure at discharge port 4. Check mounting to be sure pump is securely mounted

TROUBLESHOOTING - CAMEL DETERGENT PUMP

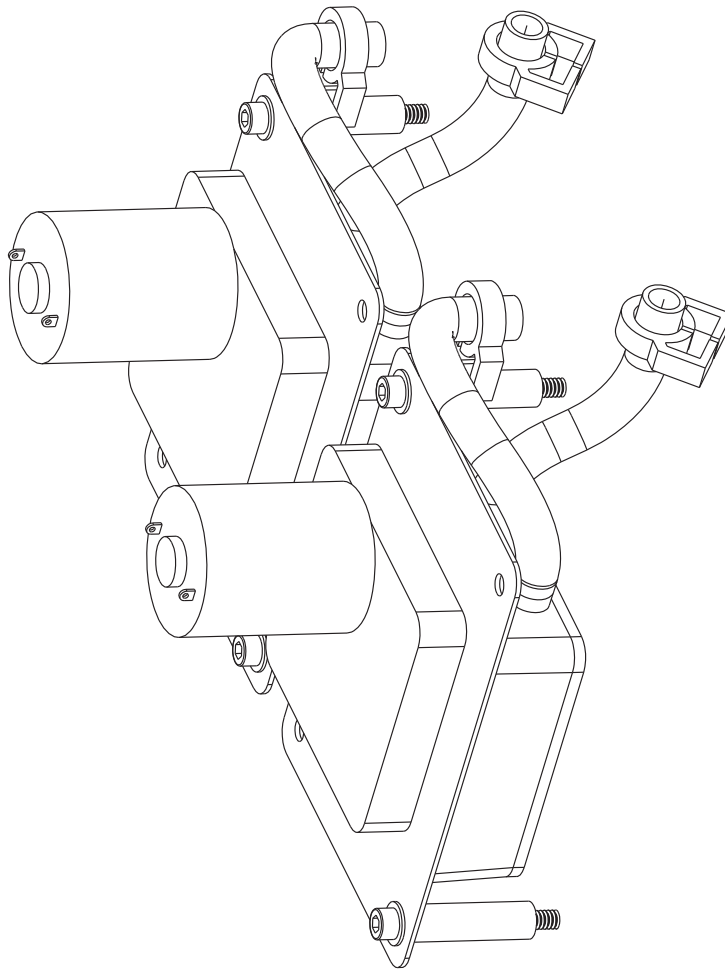

<u>PROBLEM</u>	<u>PROBABLE CAUSE</u>	<u>REMEDY</u>
Motor fails to operate (engine running)	<ol style="list-style-type: none">1. Poor electrical connection2. Defective motor3. Camel switch must be in on position	<ol style="list-style-type: none">1. Check connection and tighten2. Replace motor3. Turn Camel switch to on position
Motor operates, but pump output is low or stopped	<ol style="list-style-type: none">1. Restricted or blocked detergent lines2. Defective wiring or motor3. Fluid level low or empty	<ol style="list-style-type: none">1. Clean out detergent lines2. Replace wiring or motor3. Check fluid level

ORDERING PARTS

Parts may be ordered from American-Lincoln authorized distributors. Record the information from the American-Lincoln serial plate to avoid delays in filling your order:

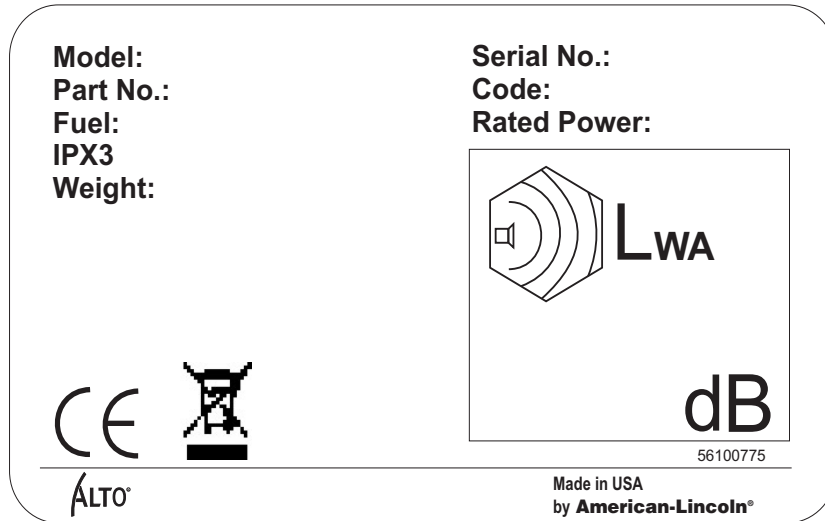

1. Use the model number, catalog number, and serial number when ordering.
2. Give the part number, description, and quantity of parts needed.
3. Give shipping instructions for either freight, UPS, or parcel post.

Parts and supplies listed in this manual can be ordered from the following address:

<p>Nilfisk-Advance, Inc. American-Lincoln Div.</p>	<p>American-Lincoln authorized distributor</p>
<p>14600 21st Avenue North Plymouth, MN 55447 1-800-214-7700</p>	

MACHINE CATALOG NUMBERS

- 510-015 SR9772 Scrubber**
- 510-017 SR9772 Scrubber w/Camel Recycling System**
- 510-016 SR9772 Scrubber w/Pressurized Cab**
- 510-018 SR9772 Scrubber w/Pressurized Cab & Camel Recycling**

TABLE OF CONTENTS - CHAPTER 2 - PARTS

Mounting Structure	2-2
Scrub Deck/Solution Control	2-4
Scrub Deck Lift (NO Cab).....	2-6
Scrub Deck Lift (CAB)	2-8
Squeegees/Squeegee Lift	2-10
Solution Tank	2-12
Solution Vacuum System.....	2-14
Solution Vac/Washer Hose (CAB)	2-16
Recovery Tank.....	2-18
Recovery Tank Lid.....	2-20
Camel Recovery Tank	2-22
Camel Pump Group.....	2-24
Camel Detergent Tank (NON-CAB).....	2-26
Camel Detergent Tank (CAB).....	2-28
Hydraulic Manifold Valve	2-30
Hyd. Cylinders & Main Pump Hoses & Fittings	2-31
Hydraulic Motor Hoses & Fittings	2-32
Brush Drive Motors & Fittings.....	2-33
Control Panel Assembly	2-34
Decals.....	2-36
Scrub Deck Hydraulics & Fittings	2-38
Scrub Deck Flap Assemblies.....	2-40
Hydraulic Schematic.....	2-41
Electrical Schematic	2-42

MOUNTING STRUCTURE

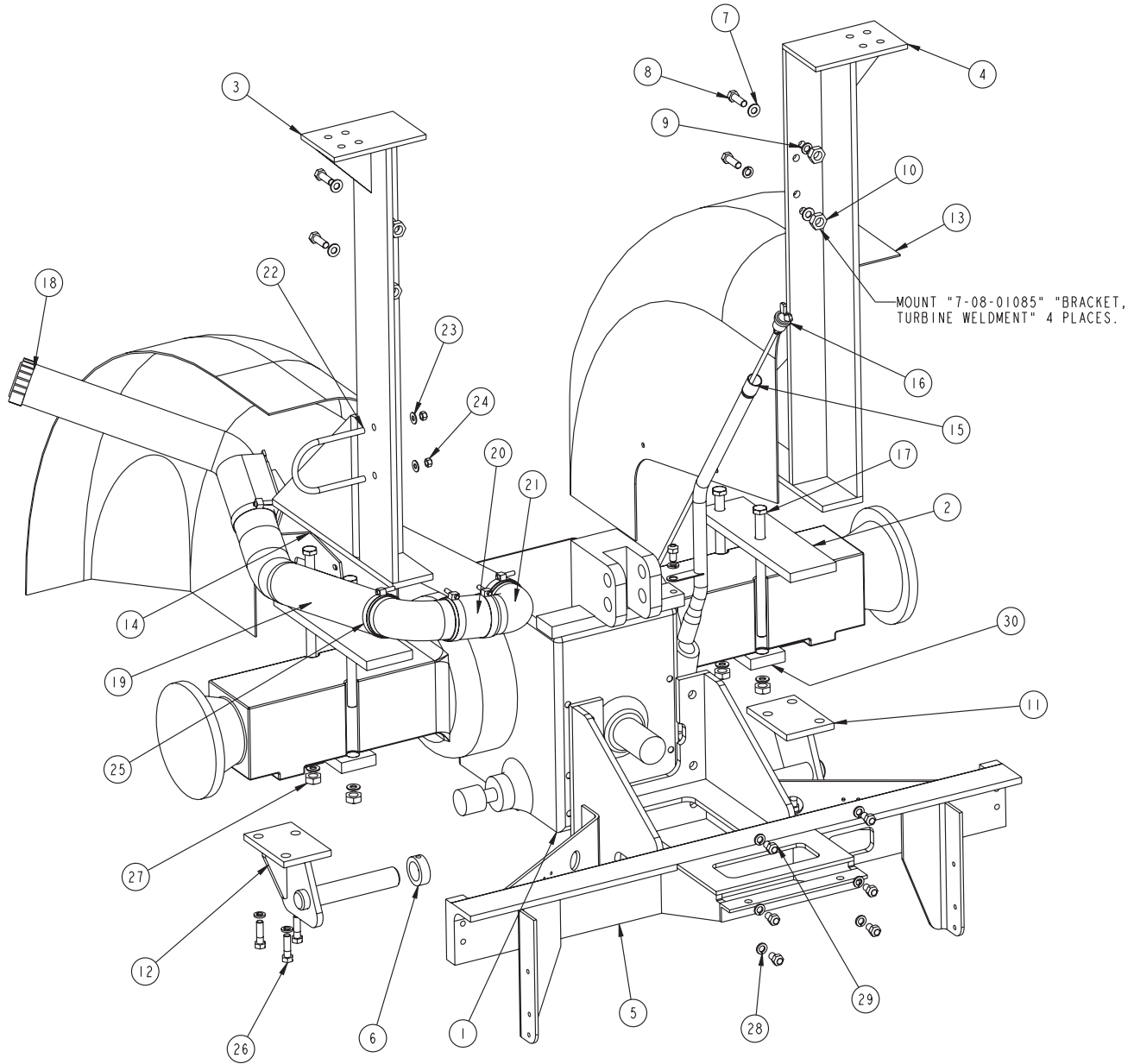

MOUNTING STRUCTURE

Item	Ref. No.	Qty	Description
1	N/A	1	Tractor, New Holland, TN55/65
2	7-75-01228	2	Spacer, Vertical Tank Support (Cab Version only)
3	7-81-00247	1	Support, Vertical Tank LH
4	7-81-00246	1	Support, Vertical Tank RH
5	7-08-01052	1	Bracket, Recovery Tank Lower
6	7-15-01032	2	Collar w/set screw
7	2-00-00405	8	Washer, Flat 1.063 x .531 x .094
8	2-00-01778	4	Hex Screw, 1/2-13 x 2.00
9	2-00-02312	10	Lock Washer, 1/2"
10	2-00-02352	4	Hex Nut, 1/2-13
11	7-08-01056	1	Bracket, Scrub Deck Lift Pivot RH
12	7-08-01055	1	Bracket, Scrub Deck Lift Pivot LH
13	N/A	1	Fender, Tractor
14	7-08-01078	1	Bracket, Fuel Filler
15	7-87-02219	1	Tube, Dipstick
16	7-11-00046	1	Dipstick, Hydraulic Fluid
17	2-00-05809	4	Hex Screw, M18 x 260
18	N/A	1	Fuel Filler
19	7-33-02536	1	Hose, 3.0" ID
20	7-33-02537	1	Hose, 3.0" OD x 4.0"
21	8-33-02366	2	Elbow, Fuel Filler
22	2-00-05693	1	U-Bolt, 3/8-16
23	2-00-00410	2	Washer, Flat, .875 x .375 x .060
24	2-95-04182	2	Hex Nut, 3/8-16 Stop
25	7-13-07104	6	Clamp, Hose
26	N/A	6	Bolt, M-14
27	2-00-05810	4	Lock Nut, M-18 x 1.5
28	N/A	7	Lock Washer, M-18
29	N/A	7	Bolt, 18mm x 50
30	7-75-01229	2	Spacer (Cab Version only)

SCRUB DECK

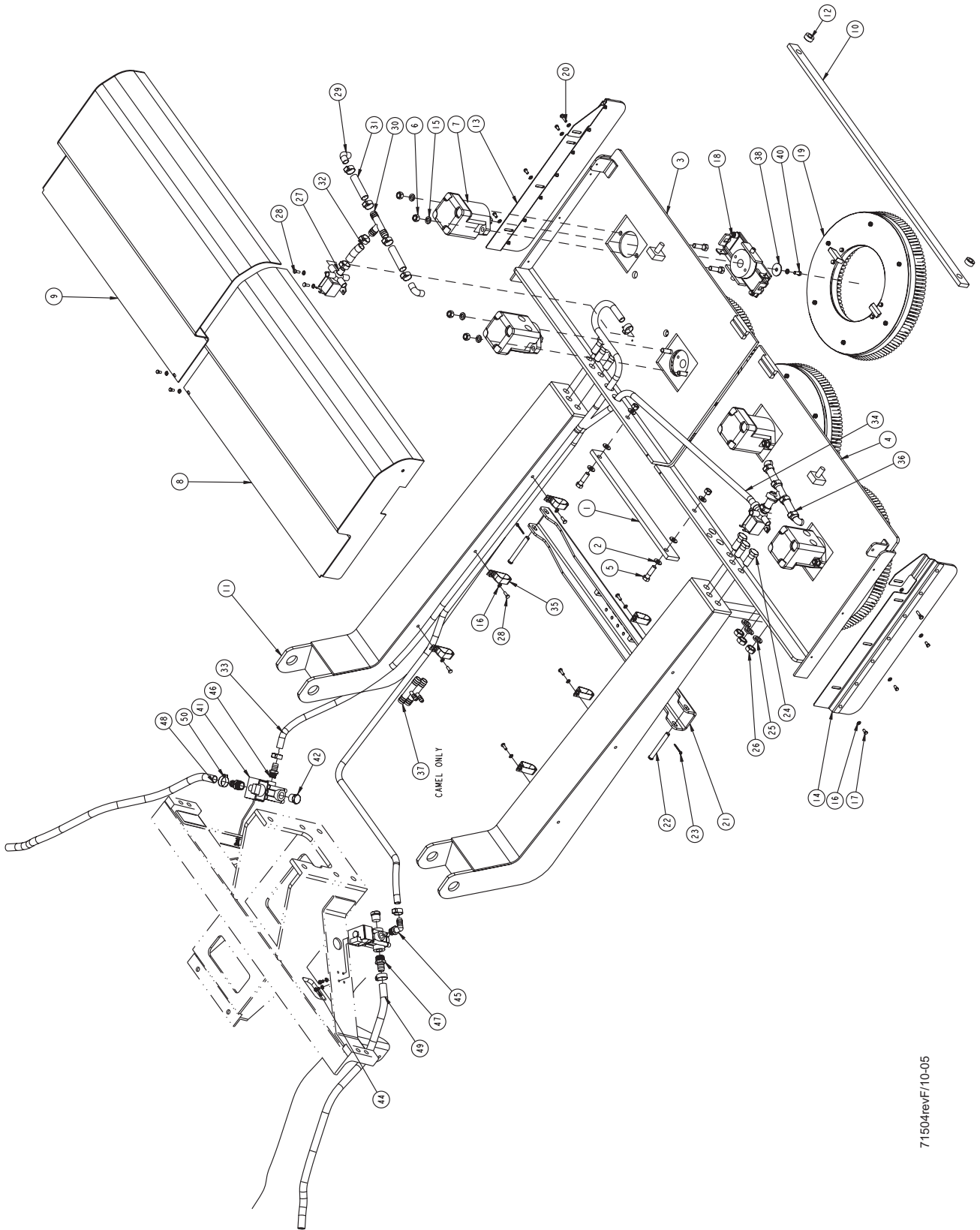

71504rev/F/10-05

SCRUB DECK

Item	Ref. No.	Qty	Description
1	7-05-07181	1	Bar, Cross Tie, Aft
2	2-00-00405	6	Flat Washer, 1.063 x .531 x .094
3	7-27-07230	1	Frame, Scrub Deck (LH)
4	7-27-07229	1	Frame, Scrub Deck (RH)
5	2-00-00241	10	Bolt, 1/2-13 x 1.75 LG
6	2-00-00596	10	Nut, Hex Head 1/2-13
7	0782-150	4	Motor, Brush Drive
8	7-16-07471	1	Cover, Brush Drive (RH)
9	7-16-07472	1	Cover, Brush Drive (LH)
10	7-05-07184	1	Bar, Cross Tie, Fwd.
11	7-03-04276	2	Arm, Scrub Deck Lift
12	8-15-01002	4	Collar, w/Setscrew
13	7-25-08097	1	Flap Assembly LH
14	7-25-08098	1	Flap Assembly RH
15	2-00-02312	8	Lock Washer, 1/2"
16	2-00-00518	20	Lock Washer, 1/4" Helical Spring
17	2-00-00219	8	Nut, Hex Head 1/4-20, Finished
18	0702-069	4	Scrub Brush Hub, 9.5" dia.
19	REF	4	Scrub Brush, 18" dia. (see "Options")
20	2-00-00244	2	Screw, 1/4-20 x 1.00 HHC
21	7-08-01330	1	Bracket, Lift Support
22	2-00-05499	2	Pin, 1/2" dia. x 4" long Clevis
23	2-00-00776	2	Cotter Pin, 1/8" dia. x 1.50" long
24	2-00-05812	6	Bolt, 3/4-10 x 1.75" Hex Head
25	2-00-05814	6	Lock Washer, 3/4" Helical Spring
26	2-00-05813	6	Nut, 3/4-10 Hex
27	7-88-00088	2	Valve, Solution (12 VDC)
28	2-00-04685	10	Screw, Hex Head, 1/4-20 x 0.75" SS
29	2-00-05380	4	Fitting, Elbow, 3/4" x 3/4", Barbed
30	2-00-05447	2	T Fitting, 3/4" x 3/4" x 3/4", Barbed
31	7-33-02560	4	Hose, 3/4" ID x 3.0"
32	7-33-02561	2	Hose, 3/4" ID x 4.0"
33	7-33-02557	1	Hose, 5/8" ID x 72"
34	7-33-02558	1	Hose, 5/8" ID x 117"
35	2-00-05253	6	Clamp, 3/4" Wire, Double
36	2-00-03407	16	Clamp, Hose, Witteck #10P
37	2-00-05718	2	T Fitting, 5/8" x 5/8" x 1/4", Barbed
38	2-00-04851	4	Washer, Engine Mount
39	2-00-00530	4	Lock Washer, 5/16"
40	2-00-05087	4	Screw, 5/16-18
41	7-88-00078	2	Valve, Solenoid (12 VDC)
42	2-00-05724	2	Fitting, 3/4 NPT Hex Plug
43	2-00-00518	4	Lock Washer, 1/4"
44	2-00-00251	4	Screw, 1/4-20
45	2-00-05803	1	Fitting, 1/2" NPT x 5/8" Hose Barbed, 90°
46	2-00-05805	1	Fitting, 1/2" NPT x 3/4" Hose Barbed, Str.
47	7-25-02012	2	Fitting, 3/4" NPT x 3/4" Barbed
48	7-33-02559	1	Hose, 3/4" ID Heater
49	7-33-02559	1	Hose, 3/4" ID Heater
50	2-00-02220	2	Clamp, Hose

SCRUB DECK LIFT (NO CAB)

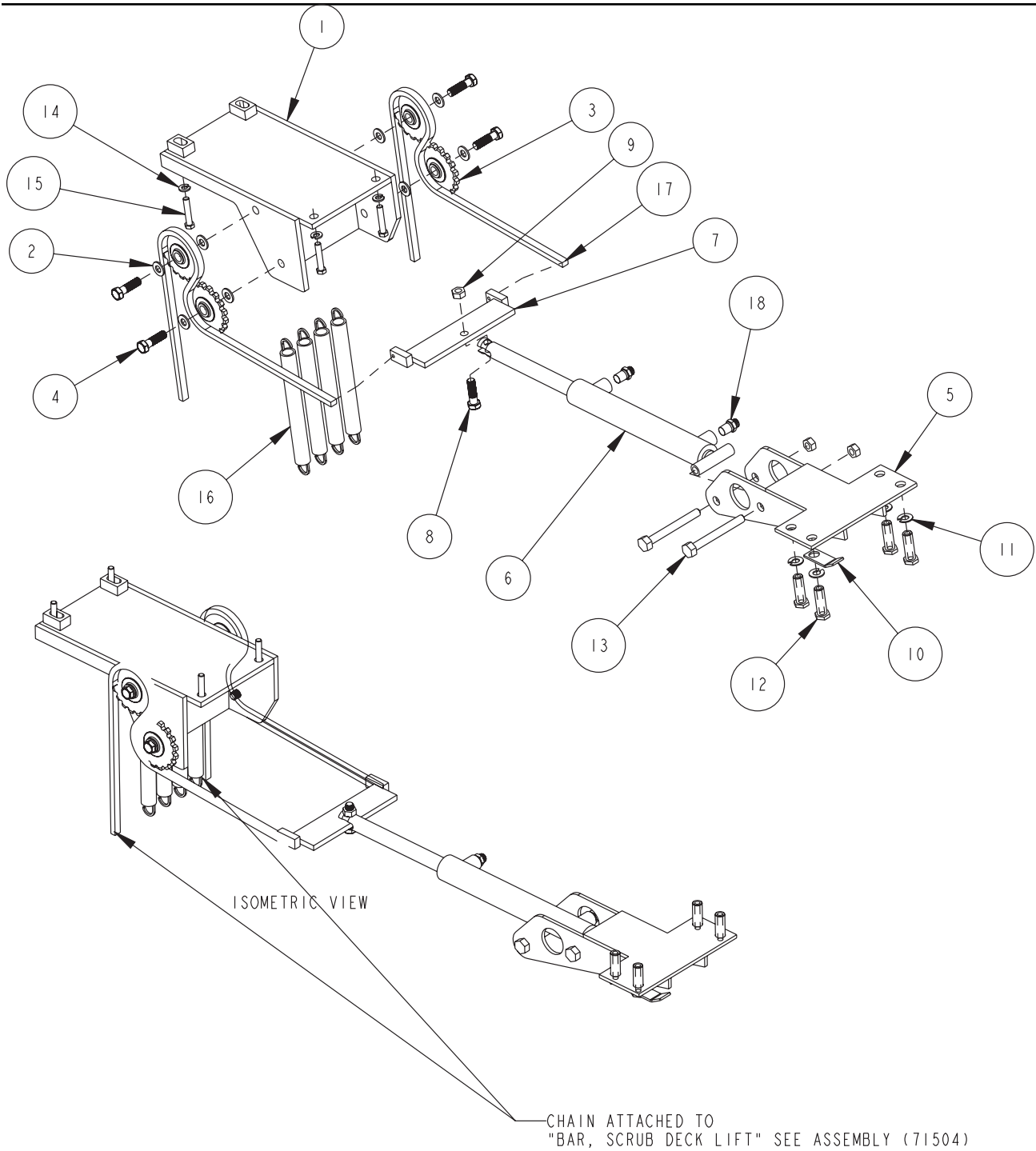

NOTE:

- 1) LUBRICATE CHAIN WITH SAE 40 OIL.
- 2) ALL BOLTS SHALL BE 45 - 55 FT./LBS. TORQUE
- 3) USE PST PIPE SEALANT ON THE HYDRAULIC CYLINDER HOSE FITTINGS "2-00-05054" ITEM # "17".

SCRUB DECK LIFT (NO CAB)

Item	Ref. No.	Qty	Description
1	7-08-01128	1	Bracket, Scrub Lift
2	2-00-00405	8	Washer Flat .063 X .531 X .094
3	8-76-05055	4	Sprocket, Idler
4	2-00-02373	4	Bolt, 5/8-18 x 1.75"
5	7-08-01062	1	Bracket, Cyliner Mounting
6	7-17-05009	1	Cylinder, Hydraulic
7	7-05-07180	1	Bar, Brush Lift Cylinder
8	2-00-02692	1	Screw, 1/2 - 20 x 1.75" Hex Head
9	2-00-00640	3	Nut, Fiber Insert 1/2 - 20
10	7-08-02036	1	Bracket, Solution Hose Crossover
11	2-00-05045	4	Lock Washer, 1/4" Helical Spring
12	2-00-05434	4	Bolt, 16mm x 1.5 x 50mm
13	2-00-02619	2	Bolt, 1/2-20 x 4.50"
14	2-00-05043	4	Washer, Plain 25/64 ID x 3/4 OD
15	2-00-04950	4	Bolt, 12mm x 1.25 x 45mm
15	8-76-00041	4	Spring, Counterbalance
16	7-13-05079	2	Chain, Scrub Deck Lift
17	2-00-05054	2	Fitting, 9/16-18 to 3/8-18 Adapter

SCRUB DECK LIFT (CAB)

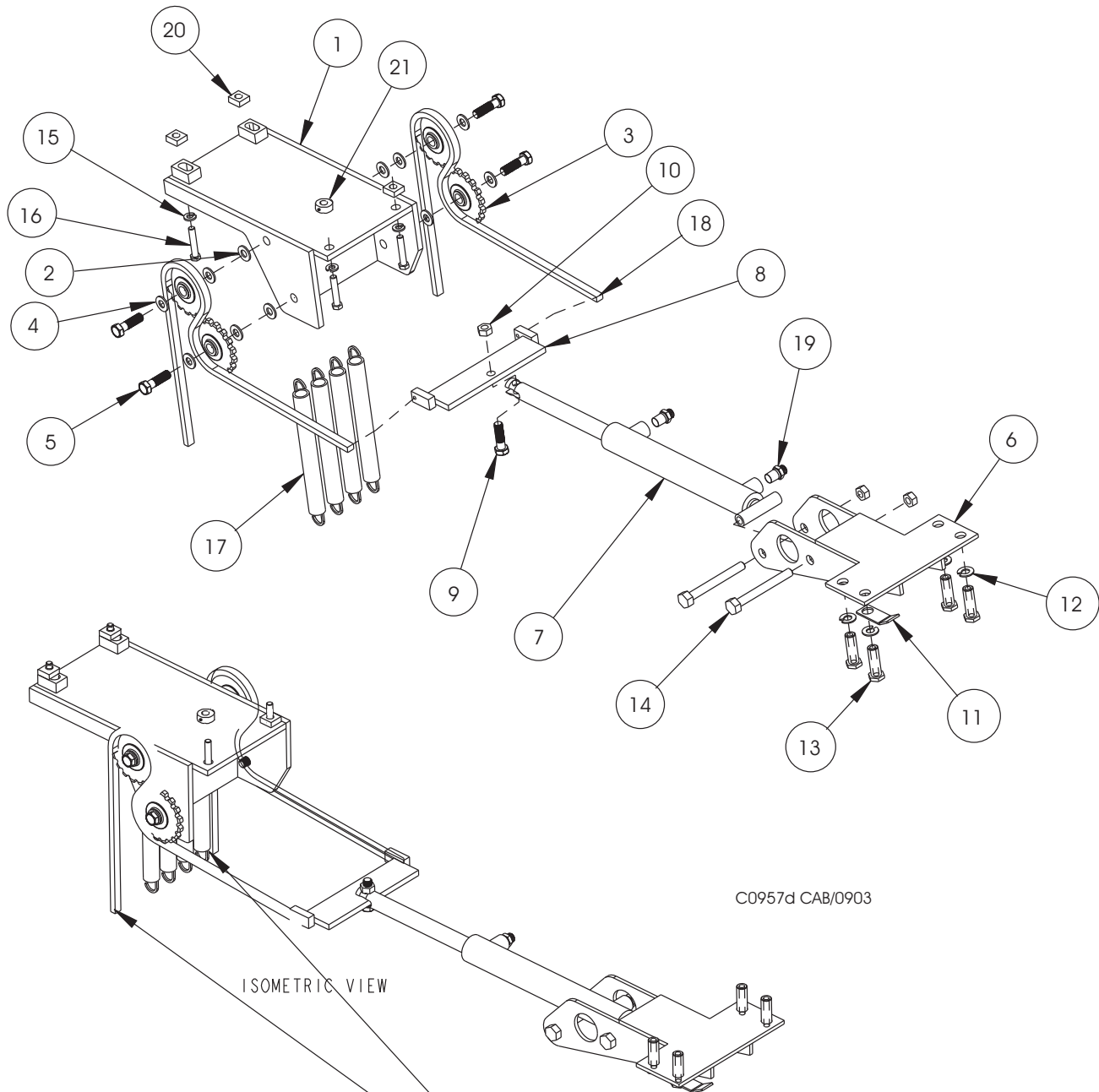

C0957d CAB/0903

ISOMETRIC VIEW

NOTE:

- 1) LUBRICATE CHAIN WITH SAE 40 OIL.
- 2) ALL BOLTS SHALL BE 45 - 55 FT./LBS. TORQUE
- 3) USE PST PIPE SEALANT ON THE HYDRAULIC CYLINDER HOSE FITTINGS "2-00-05054" ITEM # "18".

CHAIN ATTACHED TO "BAR, SCRUB DECK LIFT" SEE ASSEMBLY (71504)

SCRUB DECK LIFT (CAB)

Item	Ref. No.	Qty	Description
1	7-08-01128	1	Bracket, Scrub Lift
2	2-00-03413	8	Washer , 5/8 ID
3	8-76-05055	4	Sprocket, Idler
4	2-00-02313	4	Lock Washer, 3/4"
5	2-00-02373	4	Bolt, 5/8-18 x 1.75"
6	7-08-01062	1	Bracket, Cyliner Mounting
7	7-17-05009	1	Cylinder, Hydraulic
8	7-05-07180	1	Bar, Brush Lift Cylinder
9	2-00-02692	1	Screw, 1/2 - 20 x 1.75" Hex Head
10	2-00-00640	3	Nut, Fiber Insert 1/2 - 20
11	7-08-02036	1	Bracket, Solution Hose Crossover
12	2-00-05045	4	Lock Washer, 1/4" Helical Spring
13	2-00-05434	4	Bolt, 16mm x 1.5 x 50mm
14	2-00-02619	2	Bolt, 1/2-20 x 4.50"
15	2-00-05043	4	Washer, Plain 25/64 ID x 3/4 OD
16	2-00-05946	4	Bolt, 12mm x 1.25 x 70mm
17	8-76-00041	4	Spring, Counterbalance
18	7-13-05079	2	Chain, Scrub Deck Lift
19	2-00-05054	2	Fitting, 9/16-18 to 3/8-18 Adapter
20	7-75-01244	3	Spacer
21	2-00-03589	1	Collar, Setscrew

SQUEEGEES/SQUEEGEE LIFT

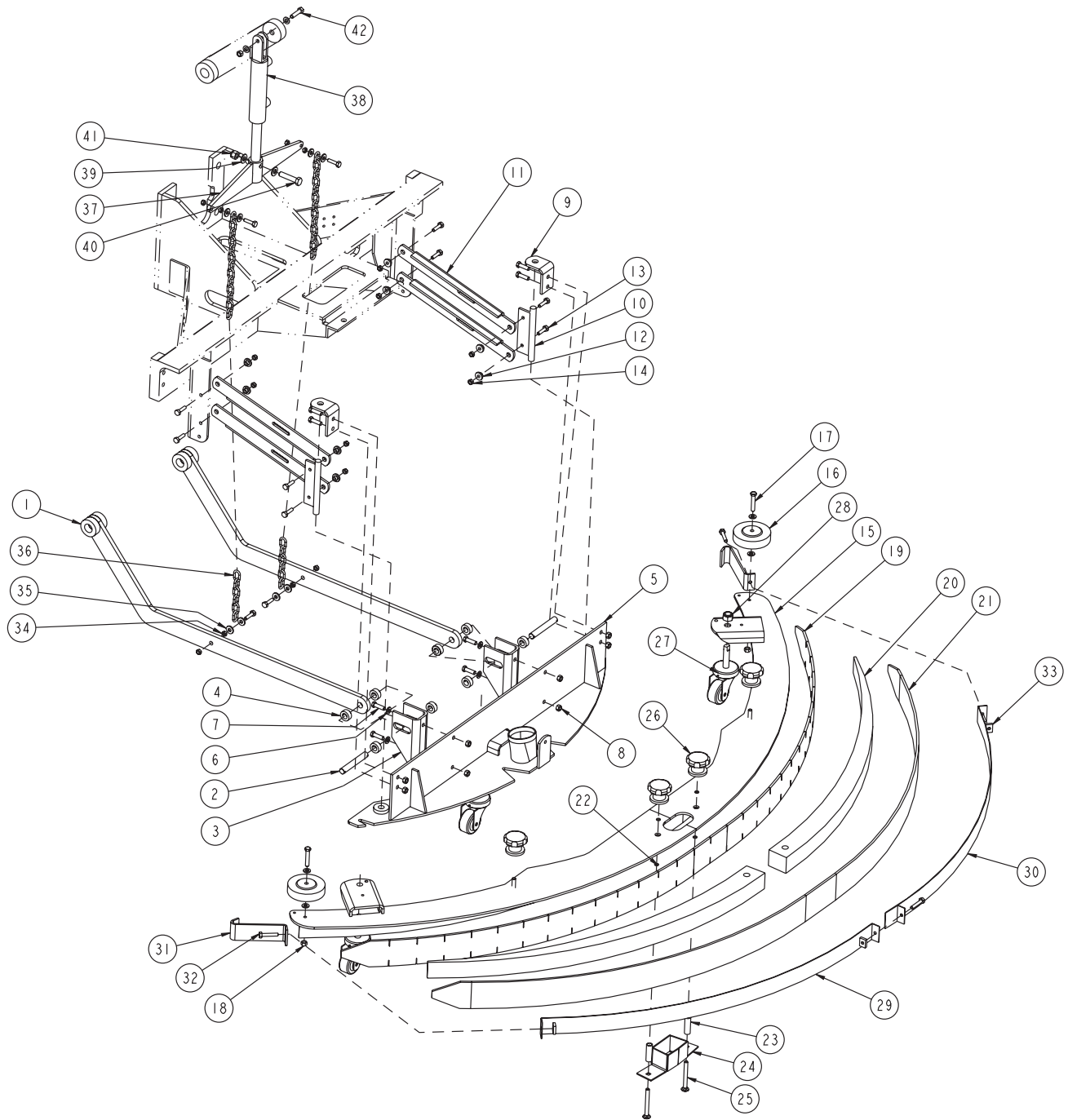

SQUEEGEES/SQUEEGEE LIFT

Item	Ref. No.	Qty	Description
1	7-03-04221	2	Arm, Squeegee Lift
2	8-55-08112	2	Pin
3	7-03-04222	2	Bracket, Squeegee Lift Arm
4	8-15-01002	8	Collar w/setscrew
5	7-86-08039	1	Support, Squeegee
6	2-00-00402	10	Washer, 25/64 ID x 3/4 OD
7	2-00-00209	8	Bolt, Hex Head, 3/4-16 x 1.25
8	2-95-04182	9	Nut, Hex, 3/8-16 Stop
9	7-08-00839	2	Bracket, Angle
10	7-55-08144	2	Pin, Rear Weldment
11	7-03-04149-1	4	Arm, Squeegee Swing
12	7-09-01057	8	Bushing, Brush Lift
13	2-00-00207	12	Screw, Hex Head, 5/16 - 18 x 1.25
14	2-00-00644	12	Nut, Insert Fiber Hex, 5/16-18
15	7-27-07213	1	Frame, Squeegee
16	2-14-00184	2	Wheel
17	2-00-00216	2	Bolt, Hex Head, 3/8-16 x 2.0
18	2-00-02360	2	Nut, Hex, 3/8-16
19	7-77-06002	1	Inner Squeegee
20	7-75-01225	2	Spacer, Squeegee
21	7-77-06008	1	Outer Squeegee
22	2-00-04962	4	O-Ring
23	7-75-01164	2	Bushing, Spacer
24	7-20-06009	1	Duct, Squeegee Inlet
25	2-00-05343	2	Carriage Bolt, 3/8-16 x 4.0
26	7-39-00026	4	Knob, Squeegee
27	7-89-08073	3	Caster
28	2-00-00615	3	Nut, Hex, 5/8-11
29	7-79-00107	1	Strap, Squeegee Clamp LH
30	7-79-00108	1	Strap, Squeegee Clamp RH
31	7-13-07157	2	Clamp, Squeegee End
32	2-00-05344	3	Bolt, Hex Head, 5/16-18 x 1.75
33	7-13-07156	3	Nut, Clamp
34	2-00-00585	4	Nut, Hex, 5/16-18
35	2-00-04801	8	Flat Washer, 1.00 x .531 x .094
36	7-13-05080	2	Chain, Rear Squeegee Lift (20 links)
37	7-03-04230	1	Arm, Squeegee Lift
38	7-17-05031	1	Cylinder, Squeegee Lift
39	2-00-00405	2	Flat Washer, 1.063 x .531 x .094
40	2-00-00242	1	Bolt, 1/2-13 x 2.0
41	2-00-04936	1	Lock Nut, 1/2-13 Elastic
42	2-00-00234	1	Screw, 3/8-16 x 1.5 HHC

Squeegee Vac Hose/Clamps: 7-33-02381 / 7-13-07104

SOLUTION TANKS

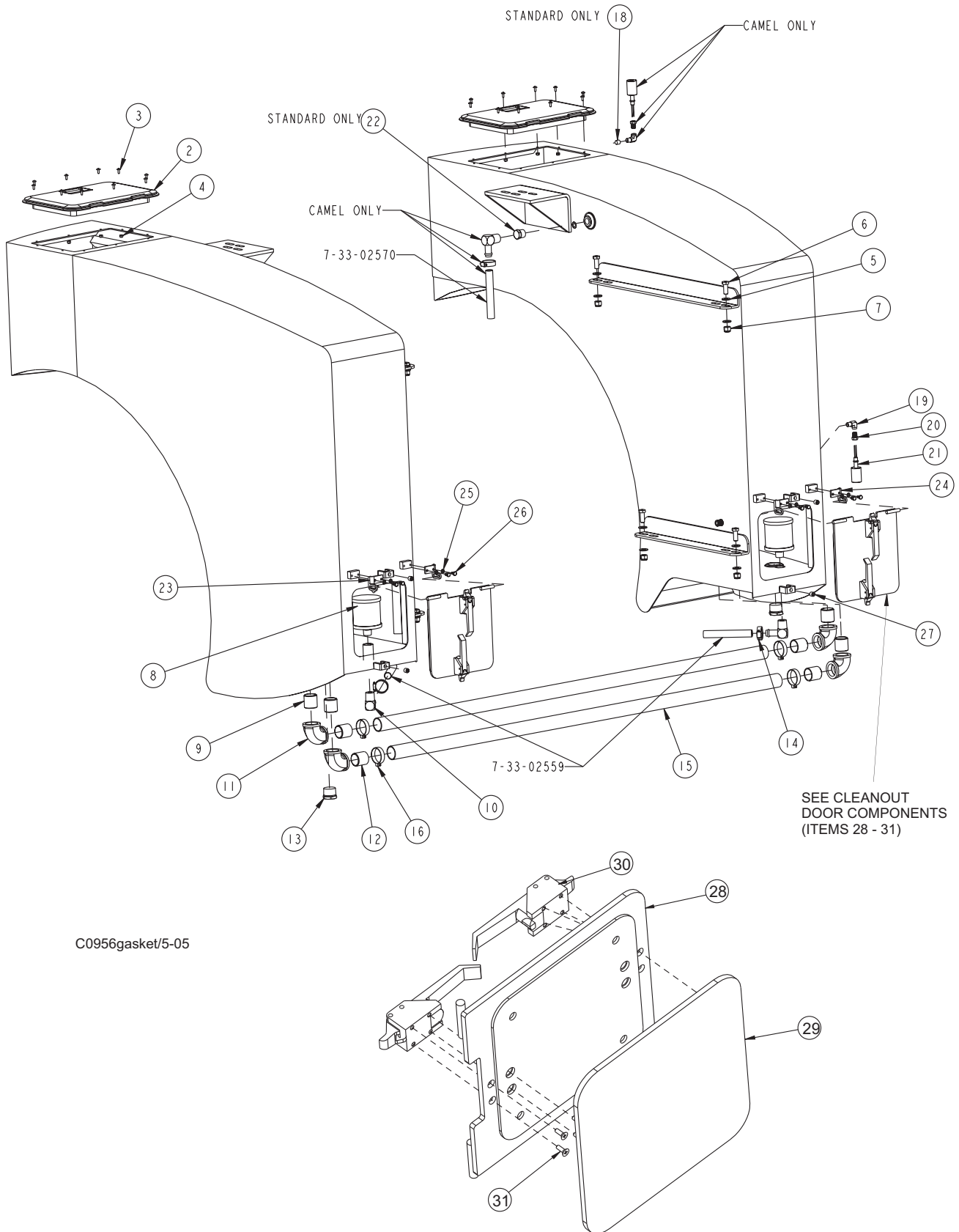

SOLUTION TANKS

Item	Ref. No.	Qty	Description
1	7-83-04220	1	L.H. Solution Tank
2	7-19-08073	2	Door, Filler
3	2-00-03061	20	Screw, #10-24 x 1.00 Truss Head
4	2-00-00605	20	Nut, 10-24 Elastic Stop
5	2-00-00405	16	Flat Washer, 1.063 x .531 x .094
6	2-00-00240	8	Screw, 1/2-13 x 1.00 Long HHC
7	2-00-04936	8	Lock Nut, Elastic, 1/2-13
8	7-24-04022	2	Strainer, Pump Inlet
9	2-00-03861	4	Fitting, 1-1/4" NPT, Close Nipple Galv.
10	7-25-02038	3	Fitting, 3/4" NPT x 3/4" Hose Barb, 90°
11	2-00-03583	4	Fitting, 1-1/4" NPT, Elbow 90° Galv.
12	8-56-05071	4	Fitting, 1-1/4" NPT, Thread One End, Black
13	2-00-00293	2	Fitting, 1-1/4" NPT, Hex Plug
14	2-00-03404	3	Clamp, Hose
15	7-33-02549	2	Hose, 1-1/2" ID x 61" Long
16	2-00-02216	4	Clamp, Hose
17	7-83-04221	1	R.H. Solution Tank
18	2-00-03525	1	Fitting, 1/4" NPT, Socket Plug
19	2-00-05678	2	Fitting, 1/4" NPT Street Elbow, 90° Brass
20	2-00-05465	2	Fitting, 1/4" NPT x 1/8" NPT Bushing12
21	7-82-00017	2	Switch, Liquid Level
22	2-00-05724	1	Fitting, 3/4" NPT, Hex Plug, Nylon
23	7-08-01190	2	Bracket, Cleanout Door Hinge
24	7-08-01191	2	Bracket, Cleanout Door Hinge
25	2-00-00518	8	Lock Washer, 1/4" Helical Spring
26	2-00-00251	8	Screw, 1/4-20 x .50 Long
27	2-00-05949	4	Set Screw, 1/2-13 x .50, Oval Point, SS
			Cleanout Door Assembly:
28	7-19-08088	2	Cleanout Door
29	7-29-00334	2	Gasket, Cleanout Door
30	7-41-00054	4	Latch, Cleanout Door
31	2-00-00009	16	Screw, 8-32 x 1.2 FHS

SOLUTION VACUUM

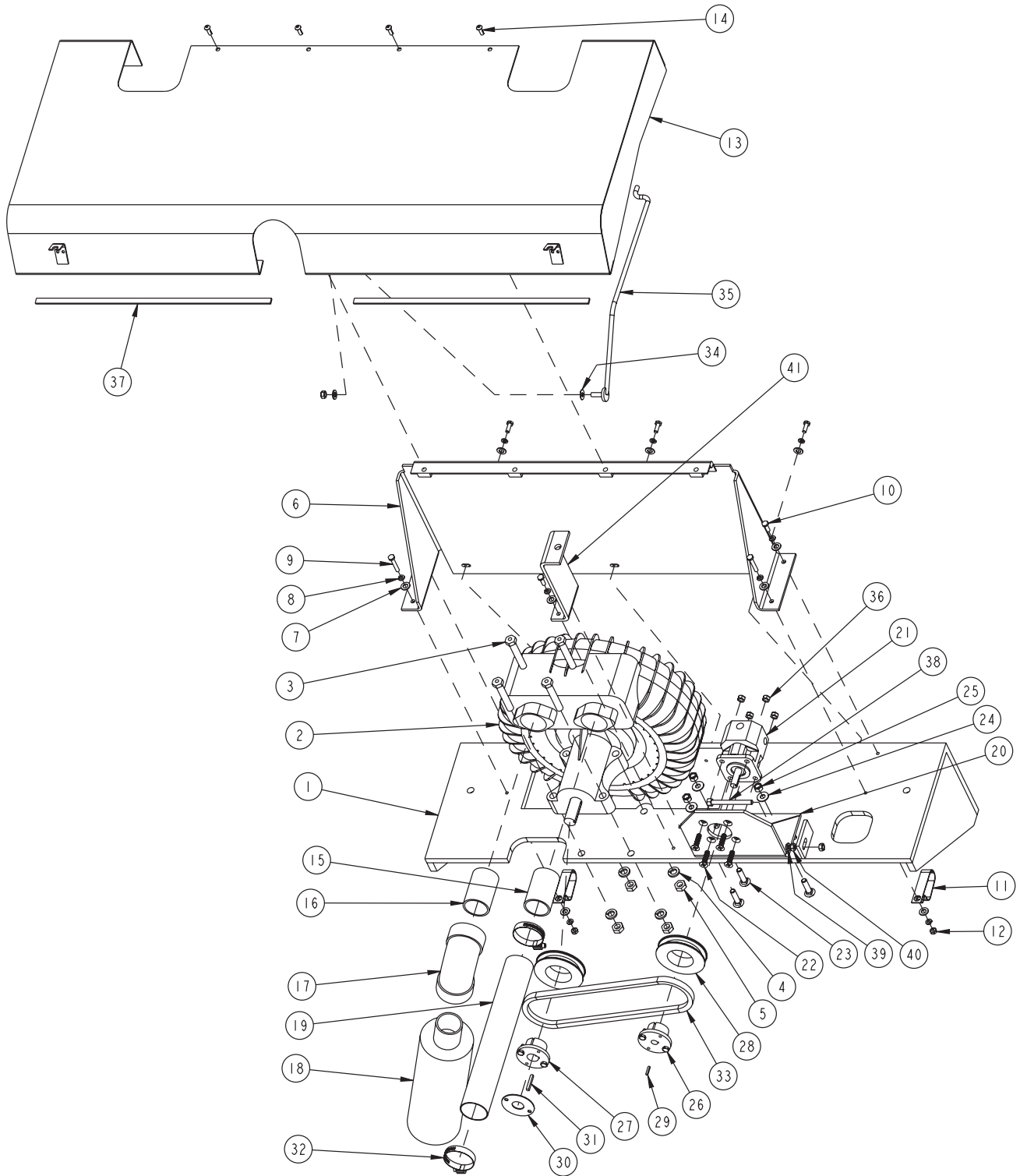

Item	Ref. No.	Qty	Description
1	7-08-01085	1	Bracket, Turbine
2	0790-045	1	Turbine, Vacuum, Ametek Rotron PN (080610)
3	2-00-02616	4	Bolt, Hex Head, 1/2-13 Finished
4	2-00-02312	4	Lock Washer, 1/2"
5	2-00-00591	4	Nut, Hex Jam, 1/2-20
6	7-52-00186	1	Panel, Turbine Back
7	2-00-00409	12	Washer, Flat, .687 x .344 x .062
8	2-00-00518	11	Lock Washer, 1/4"
9	2-00-04966	2	Screw, 1/4-20 x 1.50 HHM
10	2-00-00221	5	Screw, Hex Head, 1/4-20 x .075 SS
11	2-00-05253	2	Clamp, 3/4" Wire, Double
12	2-00-00594	2	Nut, Hex 1/4-20
13	7-16-07449	1	Cover, Turbine
14	2-00-04880	4	Screw, 1/4-20 x .75 BHS GR 8 ZN
15	2-95-02554	1	Nipple, 2" dia. x 3" NPT One Side
16	2-00-05711	1	Nipple, 2" dia. x 3" NPT
17	2-00-05710	1	Elbow, 90° , 2" x 2" NPT
18	7-49-00035	1	Muffler, Ametek Rotron PN (523623)
19	7-33-02048-1	1	Hose, Intake
20	7-08-01127	1	Bracket, Hydraulic Motor Mount
21	0782-158	1	Motor, Hydraulic
22	2-00-03298	4	Screw, Hex Head, 5/16-18 x 1.25"
23	2-00-03750	3	Bolt, Carriage, 3/8-16 x 1.5"
24	2-00-00410	3	Washer, Flat, .875 x .375 x .060
25	2-95-04182	2	Hex Nut, 3/8-16 Stop
26	7-09-01153	1	Bushing, Split Taper, 0.50" Shaft
27	7-09-01116	1	Bushing, Split Taper, 0.875" Shaft
28	7-60-00135	2	Pulley, 3.85" dia.
29	2-00-02227	1	Key, .125 x .750 SQ
30	7-65-00030	1	Retainer, Bushing Key
31	2-00-02241	1	Key, .188/.187 SQ x 1-3/8 LG
32	2-00-02217	2	Clamp, Hose
33	2-00-05540	1	Belt, Turbine Drive (A x 31) 33"
34	7-23-03048	1	Washer, Spr, Shakeproof
35	7-66-00202	1	Rod, Cover Support
36	2-00-00644	6	Hex Nut, Fiber Insert 5/16-18
37	3-73-00056	2	Gasket, Bulk, Adhesive Back (use as needed)
38	2-00-02597	1	Screw, Hex Head, 5/16-18 x 3.25"
39	2-00-00530	1	Lock Washer, 5/16"
40	2-00-00585	1	Hex Nut, 5/16-18
41	7-08-01122	1	Bracket, Prop Rod

SOLUTION VAC/WASHER HOSE (CAB ONLY)

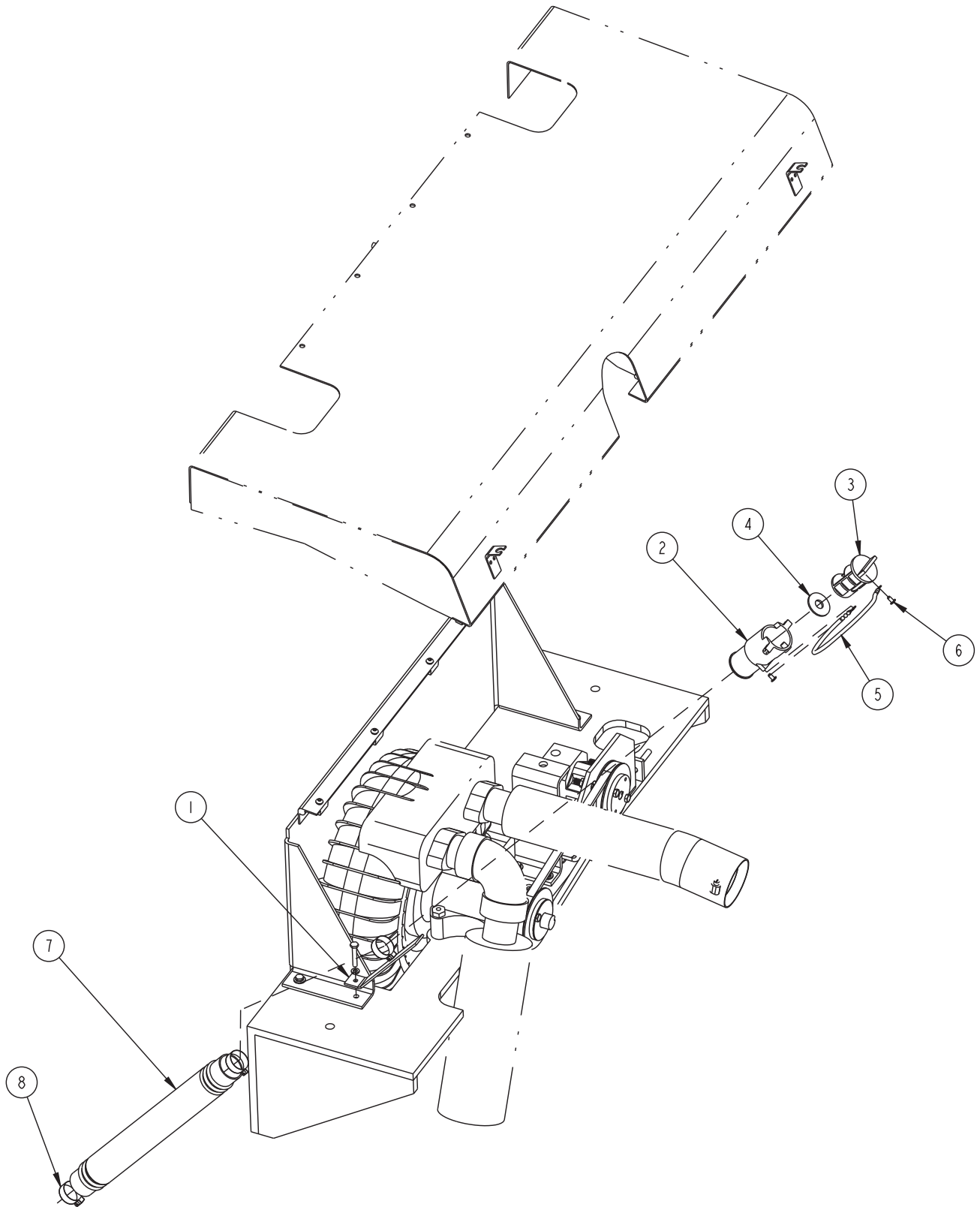

SOLUTION VAC/WASHER HOSE (CAB ONLY)

Item	Ref. No.	Qty	Description
1	7-08-02033	1	Bracket, Washer Solution Hose
2	839401	1	Valve, Drain
3	833901	1	Handle, Drain Valve
4	833407	1	Gasket, Drain
5	52206A	1	Chain, Cover Autoscrubber
6	962987	2	Screw, 10-24 x 3/8 PN ST TYP23
7	7-33-02409	1	Hose, Solution Drain
8	2-00-02220	3	Clamp, Hose

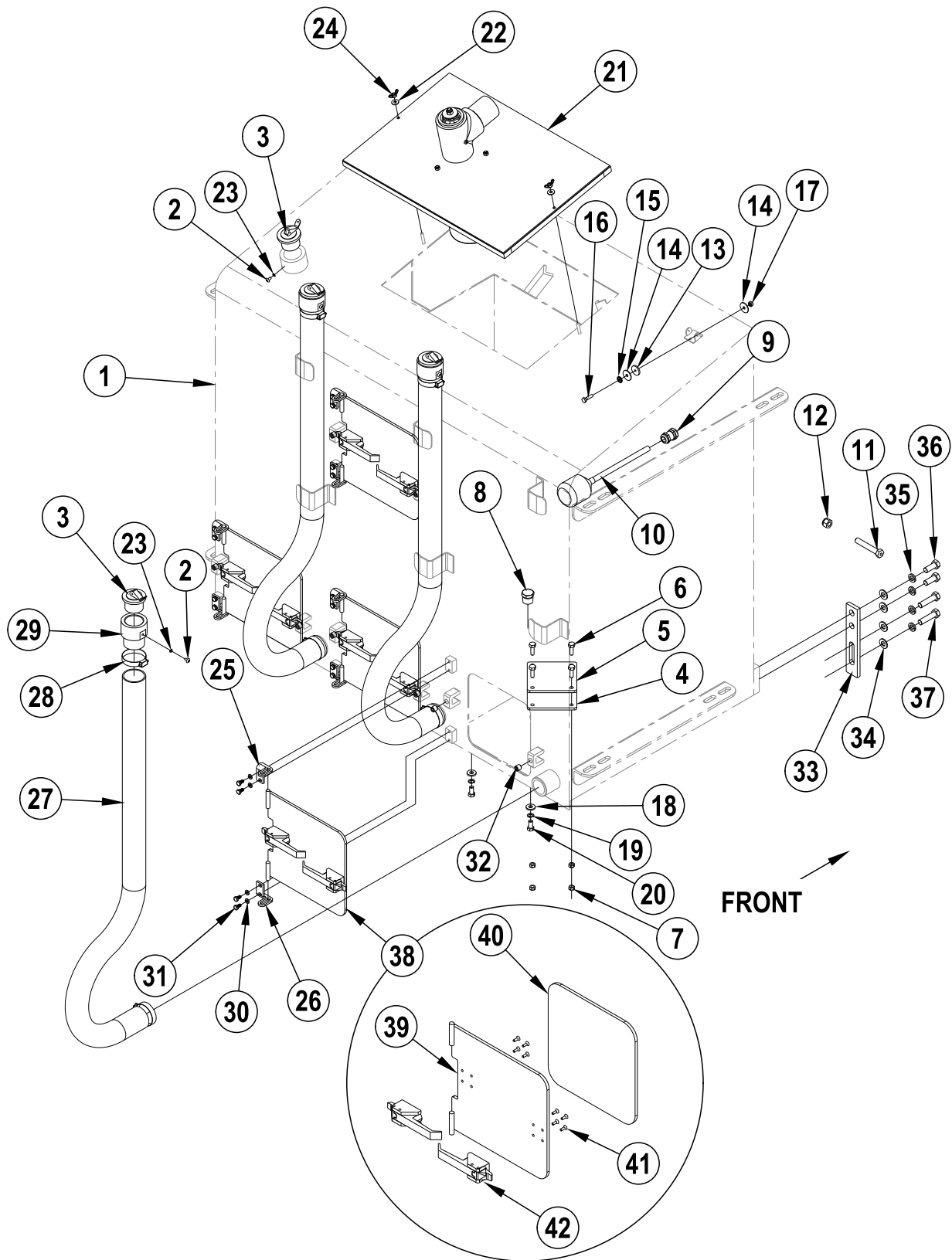

Item	Ref. No.	Qty	Description
1#	7-83-04222	1	Tank, Recovery, Weldment
2#	2-00-03059	4	Screw - No 10-24 X 3/8 Thms
3#	7-25-02033	4	Plug, Hose
4#	7-29-00294	1	Gasket, Separator Cover
5#	7-58-05320	1	Plate, Separator Cover
6#	2-00-02708	4	Screw, Hex Head, 5/16-18 X 1.00"
7#	2-00-00644	4	Nut, Hex, Insert Fiber, 5/16-18
8#	2-00-05724	1	Fitting, 3/4 Npt, Hex Plug, Nylon
9#	8-09-01083	1	Connector, Bulkhead
10#	0775-164	1	Float Switch (Red)
11#	2-00-02616	1	Bolt-Hex Head, Finished, 1/2-13
12#	2-00-04936	1	Locknut-Elastic, 1/2-13
13#	2-14-03197	1	Washer - Neoprene, 1x.19x1/8
14#	2-00-05237	2	Flat Washer - 1.063 X .265 X .063
15#	2-00-04590	1	Washer, Sealing
16#	2-00-04690	1	Screw, 1/4-20 X 1.0, Hhc
17#	2-00-00641	1	Nut, 1/4-20 Elastic Stop Nut
18#	2-00-04801	2	Flat Washer, 1.00 X .39 X .06
19#	2-00-02310	2	Washer-Lock, 3/8", Helical Spring
20#	2-00-00232	2	Bolt-Hex Head, Finished, 3/8-16
21#	71509-Sht02	1	Tank Lid Assembly
22#	2-00-04689	2	Washer, 11/16 Od X .260 Id X .050 Thk
23#	2-00-00519	4	Washer-Lock, #10-24, Helical Spring
24#	2-00-00672	2	Wing Nut, 1/4-20
25#	7-08-01191	4	Bracket, Clean Out Door Hinge
26#	7-08-01190	4	Bracket, Clean Out Door Hinge
27#	7-33-02291	3	Hose, 1.5" Id X 48" Long
28#	2-00-02214	6	Hose Clamp
29#	7-25-02032	3	Fitting, 1.5" Hose Plug Adapter
30#	2-00-00518	16	Washer, Lock, 1/4, Helical Spring
31#	2-00-00251	16	Screw, 1/4-20 X .50 Long
32#	2-00-05949	8	Set Screw, 1/2-13 X .5, Oval Point, Ss
33#	7-08-01121	2	Bracket, Recovery Tank, Lower
34#	2-00-00405	8	Flat Washer, 1.063 X .531 X .094
35#	2-00-02312	8	Washer, 1/2 Lock
36#	2-00-00240	4	Screw, 1/2-13 X 1.250 Hhc
37#	2-00-01778	4	Screw, 1/2-13 X 2.00 Hhc
38#	7-19-08090	4	Cleanout Door Assy (39-42)
			Cleanout Door Assembly:
39#	7-19-08088	1	Cleanout Door
40#	7-29-00334	1	Gasket, Cleanout Door
41#	2-00-00009	8	Screw, 8-32 x 1.2 FHS
42#	7-41-00054	2	Latch, Cleanout Door

= Revised or new since last update

RECOVERY TANK LID

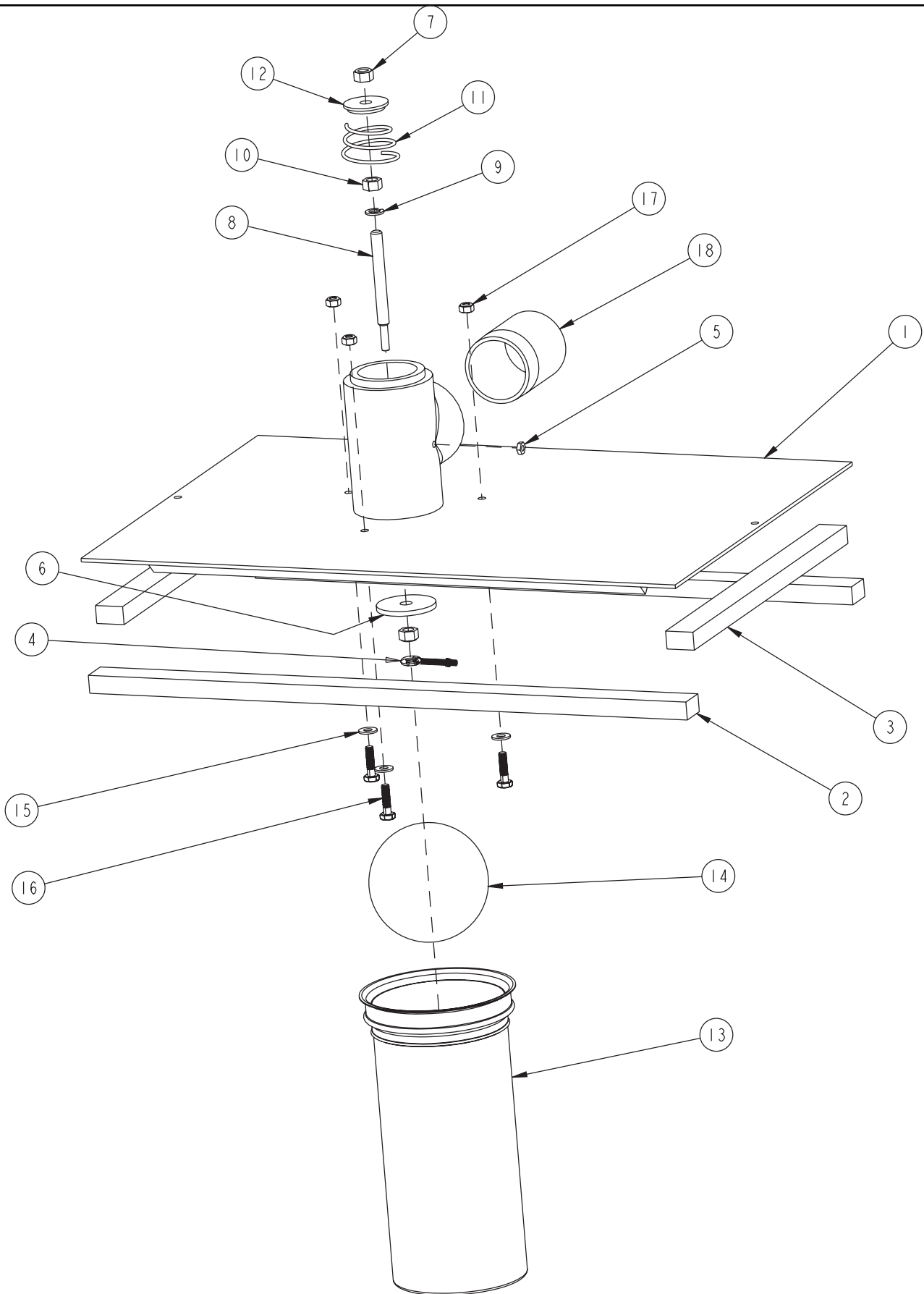

RECOVERY TANK LID

Item	Ref. No.	Qty	Description
1	7-19-08072	1	Cover, Turbine Inlet
2	7-29-00082	2	Gasket, 5/8 x 1.0 x 21.88
3	7-29-00081	2	Gasket, 5/8 x 1.0 x 12.81
4	2-00-04817	1	Eyebolt, 10-24 x .32 x 2.0
5	2-00-00605	1	Hex Nut, 10-24
6	2-95-04689	1	Washer, Axle
7	2-95-04182	2	Hex Nut, 3/8-16 Stop
8	7-66-00141	1	Rod, Valve Stem
9	2-00-02310	1	Lock Washer, 3/8" Helical Spring
10	2-00-00593	1	Nut, 3/8-16
11	7-76-00052-1	1	Spring, Conic
12	7-11-00032	1	Cap, Spring
13	7-10-04006	1	Cage, Float
14	7-26-04009	1	Float, 4" Dia.
15	2-00-03702	3	Washer, .625 x .281 x .063
16	2-00-00251	3	Screw, 1/4-20 x .50
17	2-00-00641	3	Nut, 1/4-20 Elastic Stop
18	2-95-02554	1	Fitting, 2" NPT x 3.0" Half Nipple

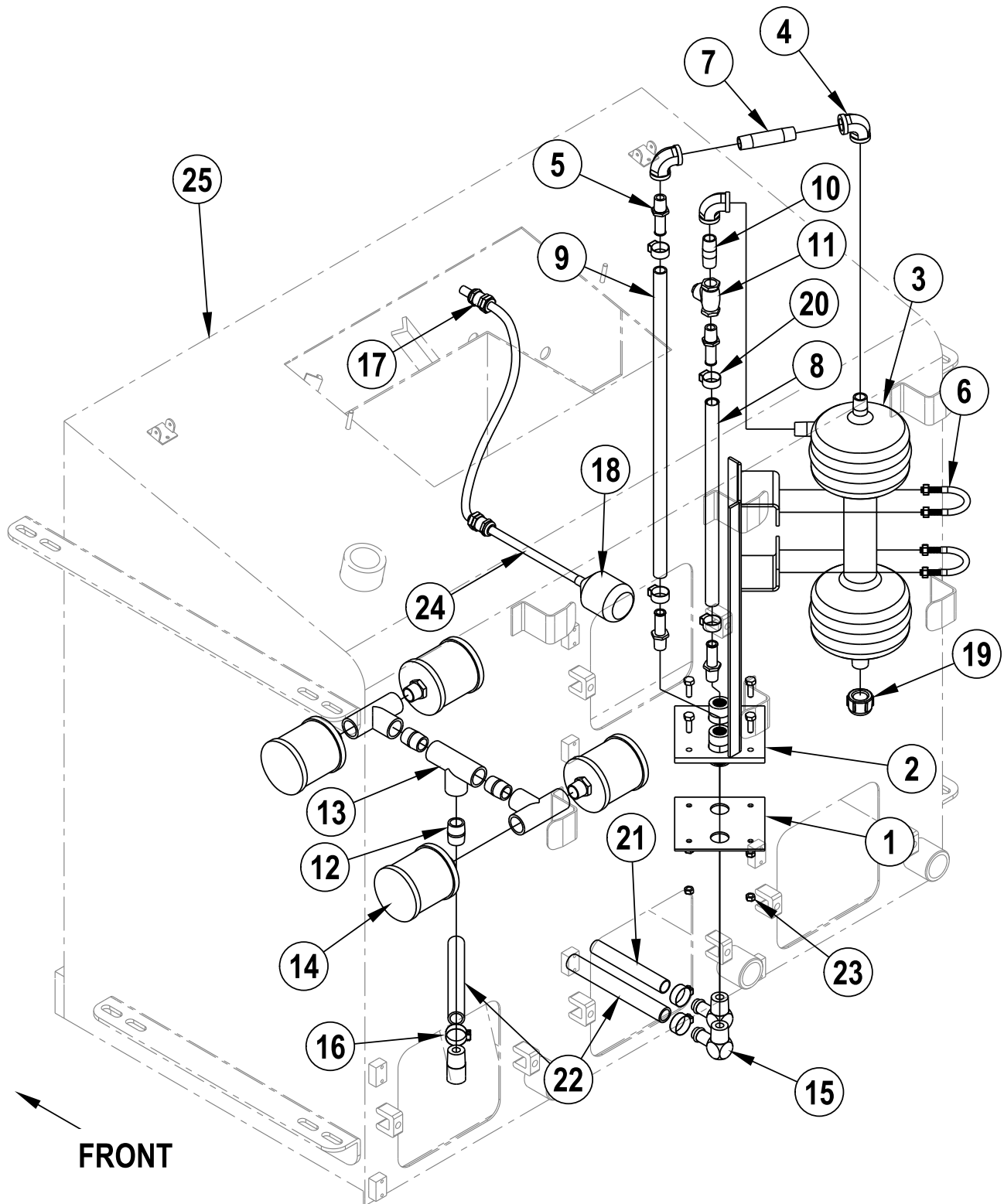

Item	Ref. No.	Qty	Description
1	7-29-00112	1	Gasket, Separator
2	7-25-02034	1	Fitting, Separator Mtg.
3	7-24-04036	1	Filter, Inline Separator
4	2-95-02527	3	Fitting, 1/2 NPT, Elbow, 90° Galv.
5	7-25-02040	4	Fitting, .50 NPT, .62 Hose
6	2-00-04579	2	U-Bolt
7	2-95-02517	1	Fitting, 1/2 NPT, Nipple, 3.5" Galv.
8	7-33-02155	1	Hose, Separator Inlet
9#	7-33-02156	1	Hose, Separator Outlet
10	2-00-04682	1	Fitting, 1/2 NPT, Nipple, 2.00" Galv.
11	7-88-00030	1	Check Valve, 1/2 NPT
12	7-25-02036	3	Fitting, Plastic
13	7-25-02037	3	Fitting, Plastic (Tee)
14	7-24-04022	4	Strainer, PUmp Inlet
15#	7-25-02038	3	Fitting, 3/4" NPT x 3/4" Hose Barb, 90° Brass
16	2-00-02220	3	Clamp, Hose
17	8-09-01083	2	Connector, Bulkhead
18	7-82-00021	1	Switch, Float (Red)
19	7-56-05012	1	Fitting, Separator Hose
20	2-00-03407	4	Clamp, Hose, Witteck #10P
21#	7-33-02570	1	Hose, 3/4" ID x 60" Long
22#	7-33-02598	2	Hose-Solution Feed
23#	2-00-00644	4	Nut, Hex, Insert Fiber, 5/16-18
24#	7-33-02487	1	Sleeve, 11"
25#	7-83-04222	1	Tank, Recovery, Weldt

= Revised or new since last update

CAMEL OPTION/PUMP GROUP

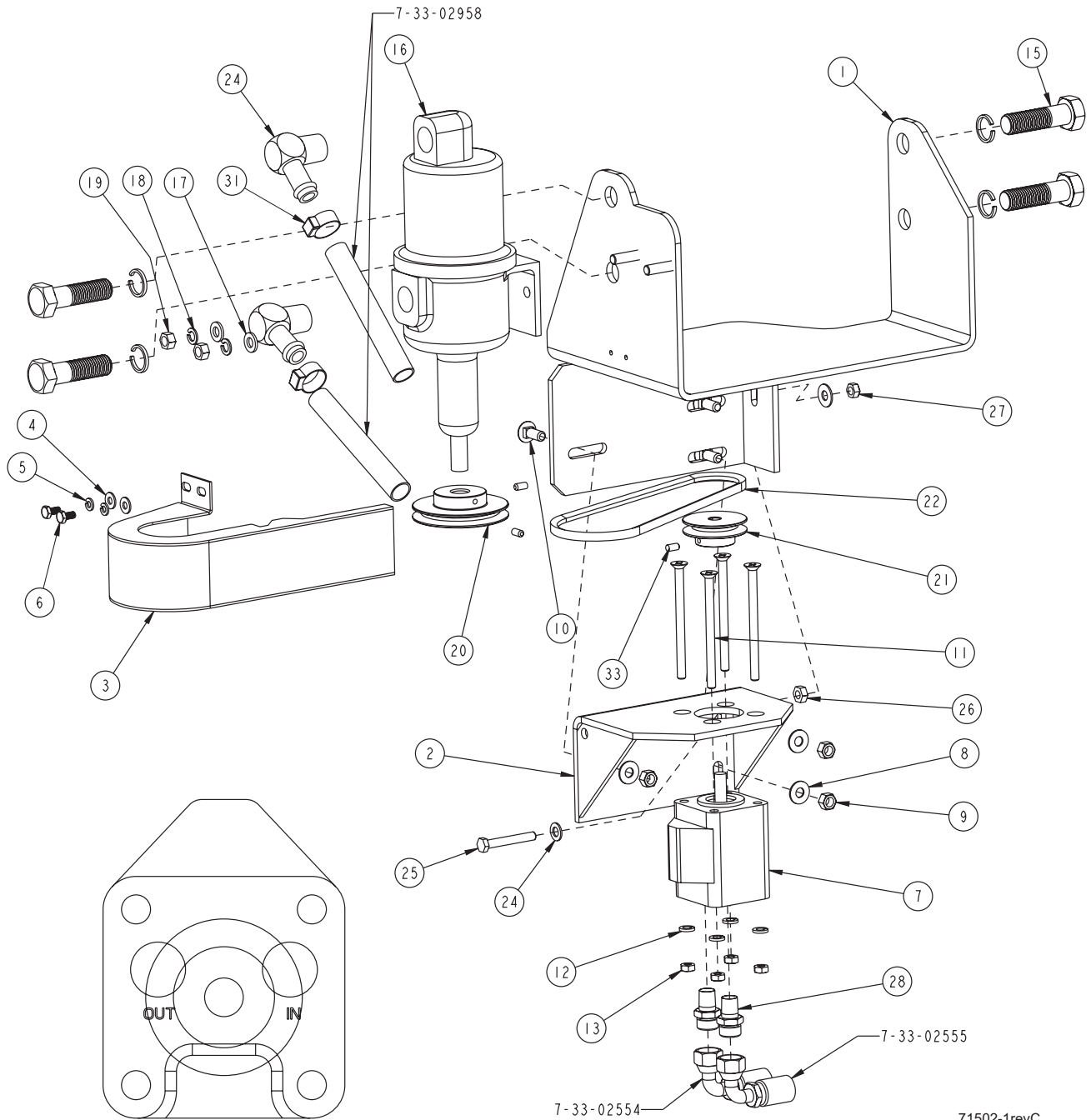

CAMEL OPTION/PUMP GROUP

Item	Ref. No.	Qty	Description
1	7-08-01306	1	Bracket, Solution Pump
2	7-08-01127	1	Bracket, Hydraulic Motor Mount
3	7-16-07444	1	Cover, Camel Pump Pulley
4	2-00-03702	2	Washer, .625 x .281 x .063
5	2-00-00518	2	Lock Washer 1/4"
6	2-00-00251	2	Screw, 1/4-20 x .50
7	0782-128	1	Motor, Hydraulic
8	2-00-00410	4	Washer, Flat, .875 x .375 x .060
9	2-95-04182	3	Hex Nut, 3/8-16 Stop
10	2-00-03855	3	Bolt, Carriage, 3/8-16 x 1.0"
11	2-00-04506	4	Screw, 5/16 Flat Head
12	2-00-00530	4	Lock Washer, 5/16"
13	2-00-00585	4	Nut, Hex, 5/16-18
14	2-00-05941	4	Lock Washer, 21M
15	2-00-05817	4	Screw, M20 x 2.5 x 40mm
16	7-60-05007	1	Pump, Progressive Cavity
17	2-00-00402	2	Washer, 25/64" ID x 3/4" OD
18	2-00-02310	2	Lock Washer, 3/8" Helical Spring
19	2-00-02360	2	Nut, Hex, 3/8-16
20	7-60-00163	1	Pulley, V-Belt, 3.65" OD x .625" ID
21	7-60-00164	1	Pulley, V-Belt, 2.44" OD x .44" ID
22	2-00-05178	1	Belt, 3VX250
23	7-25-02038	2	Fitting, 3/4" NPT x 3/4" Hose Barb, 90°
24	2-00-00409	1	Washer, Flat, .687 x .344 x .062
25	2-00-04303	1	Screw, 5/16-18 x 2.25
26	2-00-02341	1	Nut, Hex Jam, 5/16-18
27	2-00-00644	1	Nut, Hex, 5/16-18, Insert Fiber
28	2-00-05195	2	Fitting, -8 ORS x 3/8 NPT, Straight
29	7-33-02554	1	Hose, -8 ORS STR. x 90° (113.5" long)
30	7-33-02555	1	Hose, -8 ORS STR. x 90° (116" long)
31	2-00-03407	2	Clamp, Hose, Witteck #10P
32	2-00-00281	1	Set Screw, 8-32 x 1/2
33	2-00-00287	1	Set Screw, 1/4-20 x 1/2

CAMEL DETERGENT TANK (NON-CAB)

Item	Ref. No.	Qty	Description
1	7-83-04197	1	Tank, Non-Cab
2	2-00-05816	2	Washer, Flat, 21mm x 37mm x 2.7mm, 18-8 SS
3	2-00-05817	2	Screw, M20 x 2.5 x 40mm
4	8-75-01207	4	Spacer, Tail Light Mtg.
5	7-60-05031	2	Pump, Peristaltic Metering
6	2-00-00426	4	Washer, Flat, .500 x .219 x .063
7	2-00-05056	4	Screw, 10-24 x 2.00 HSHC
8	7-16-07447	1	Cover, Detergent Pump
9	2-00-00518	2	Lock Washer, 1/4" Helical Spring
10	2-00-00220	2	Bolt, Hex Head, 1/4-20 Finished
11	2-00-05678	1	Fitting, 1/4" NPT Street Elbow, 90° Brass
12	2-00-05465	1	Fitting, 1/4" NPT x 1/8" NPT Bushing
13	7-82-00017	1	Switch, Liquid Level
14	7-11-00031	1	Filter, Detergent Filler
15	2-00-00068	6	Screw, 8-32 x .625 RHM
16	7-08-01051	1	Bracket, Detergent Tank Mounting
17	2-00-00402	1	Washer, 25/64 ID x 3/4 OD
18	2-00-02310	1	Lock Washer, 3/8" Helical Spring
19	2-00-00233	1	Bolt, Hex Head, 3/8-16 x 1.00 Finished
20	2-00-01803	1	Washer
21	2-00-05041	1	Lock Washer, M8 Helical Spring
22	2-00-05412	2	Reducer Connection
23	2-00-05947	2	Fitting, Elbow
24	7-33-02686	2	Hose
25	7-13-07084	4	Clamp, Hose

CAMEL DETERGENT TANK (CAB)

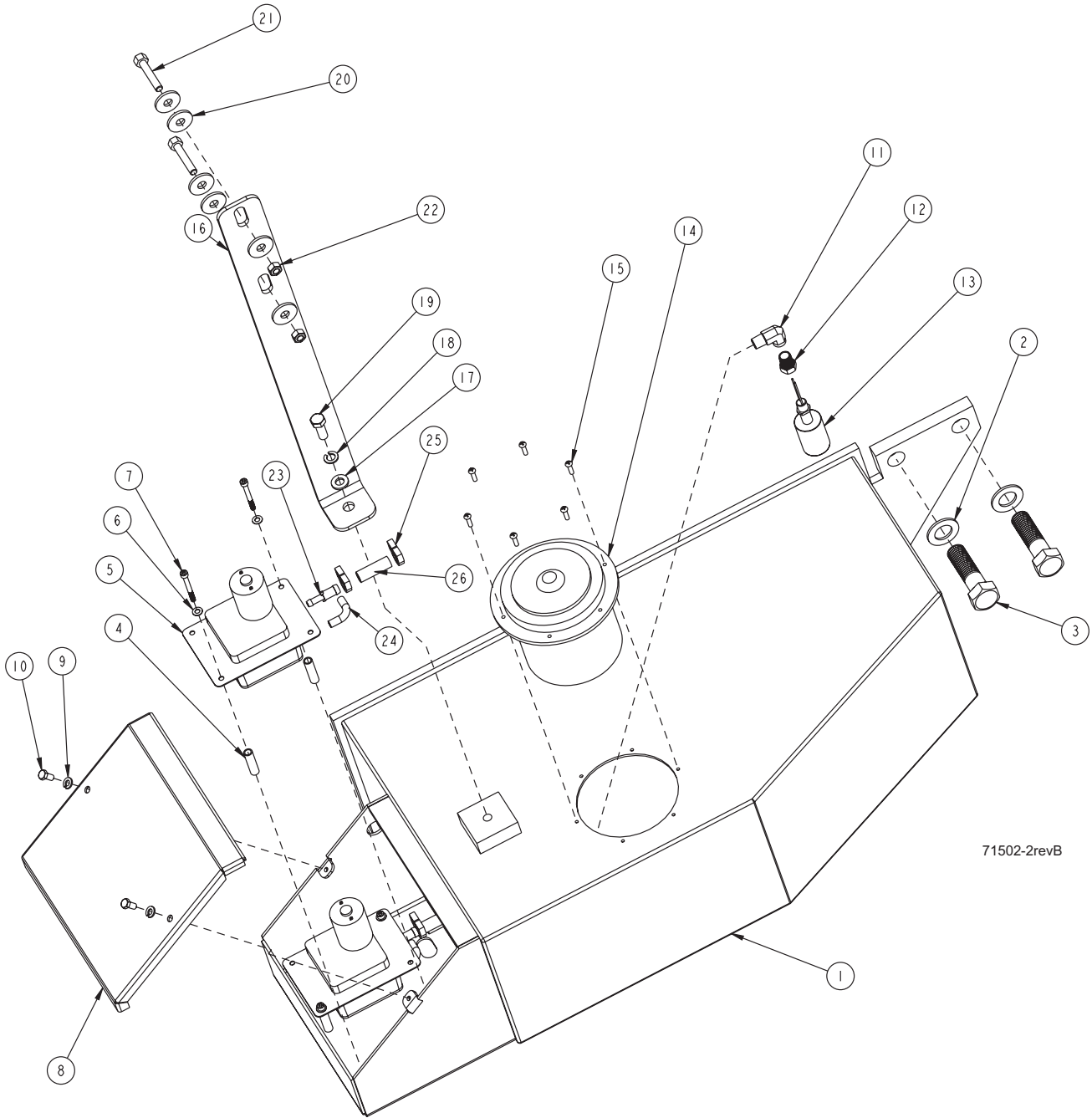

71502-2revB

BULK HOSE #3-71-07084

CAMEL DETERGENT TANK (CAB)

Item	Ref. No.	Qty	Description
1	7-83-04207	1	Tank, Cab
2	2-00-05816	2	Washer, Flat, 21mm x 37mm x 2.7mm, 18-8 SS
3	2-00-05817	2	Screw, M20 x 2.5 x 40mm
4	8-75-01207	4	Spacer, Tail Light Mtg.
5	7-60-05031	2	Pump, Peristaltic Metering
6	2-00-00426	4	Washer, Flat, .500 x .219 x .063
7	2-00-05056	4	Screw, 10-24 x 2.00 HSHC
8	7-16-07447	1	Cover, Detergent Pump
9	2-00-00518	2	Lock Washer, 1/4" Helical Spring
10	2-00-00220	2	Bolt, Hex Head, 1/4-20 Finished
11	2-00-05678	1	Fitting, 1/4" NPT Street Elbow, 90° Brass
12	2-00-05465	1	Fitting, 1/4" NPT x 1/8" NPT Bushing
13	7-82-00017	1	Switch, Liquid Level
14	7-11-00031	1	Filter, Detergent Filler
15	2-00-00068	6	Screw, 8-32 x .625 RHM
16	7-08-01117	1	Bracket, Detergent Tank Fender Mount
17	2-00-00402	1	Washer, 25/64 ID x 3/4 OD
18	2-00-02310	1	Lock Washer, 3/8" Helical Spring
19	2-00-00233	1	Bolt, Hex Head, 3/8-16 x 1.00 Finished
20	2-00-01803	6	Washer
21	2-00-04949	2	Screw, M8 x 1.25 x 45mm
22	2-00-05821	2	Nut, M8 x 1.25 Elastic Stop
23	2-00-05412	2	Reducer Connection
24	2-00-05947	2	Fitting, Elbow
25	7-13-07084	4	Clamp, Hose
26	7-33-02686	2	Hose

HYDRAULIC VALVE MANIFOLD

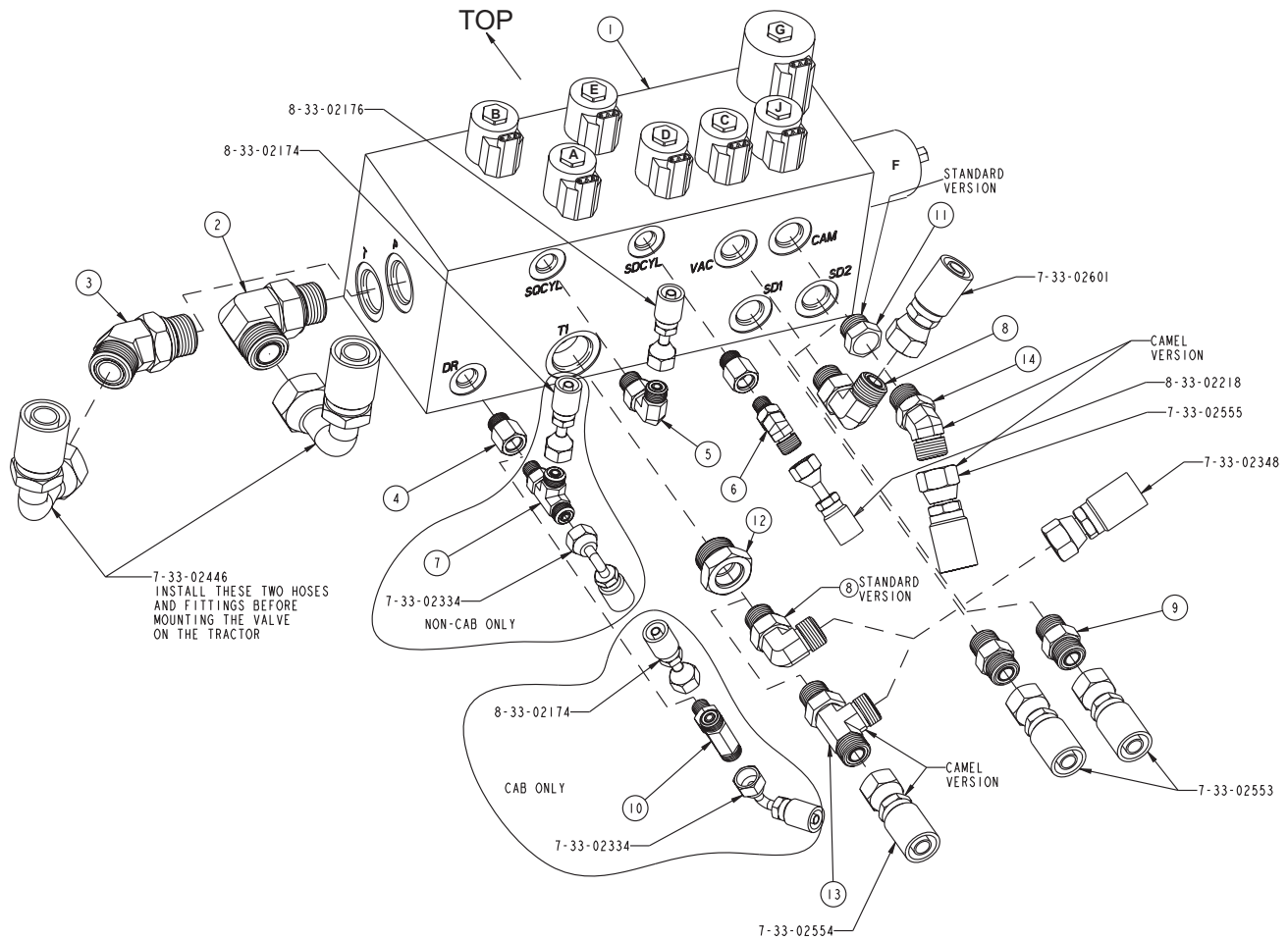

Item	Ref. No.	Qty	Description
1	7-88-00094	1	Valve, Manifold
2	2-00-04972	1	Fitting, -12 ORS x -12 SAE, 90°
3	2-00-04931	1	Fitting, -12 ORS x -12 SAE, 45°
4	2-00-04917	2	Fitting, Reducer, -6 ORB x -4 ORB
5	2-00-04926	1	Fitting, Elbow, 9/16-18 x 9/16-18
6	2-00-04976	1	Fitting, -4 ORB x -4 ORS Elbow, 45°
7	2-00-04927	1	Fitting, Elbow, 9/16-20 x 9/16-18 Tee
8	2-00-04885	2	Fitting, 90° Elbow (O-Ring)
9	2-00-04970	2	Fitting, Str., -8 ORS x -8 SAE
10	2-00-04919	1	Fitting, -4 ORS x -4 ORS x -4 SAE, Branch Tee
11	2-00-05196	1	Fitting, -8 ORB, Hex Plug
12	2-00-02036	1	Fitting, -12 SAE x -8 SAE, Reducer Bushing
13	2-00-04924	1	Fitting, 3/4-16 x 3/16-16 Tee (Camel only)
14	2-00-04975	1	Fitting, 8 SAE Elbow, 45° (Camel only)
15	2-00-02310	4	Lock Washer, 3/8" Helical Spring
16	2-00-04705	4	Bolt, 3/8-16 x 1.25 LG Finished Hex Head

CYLINDERS & MAIN PUMP HOSES & FITTINGS

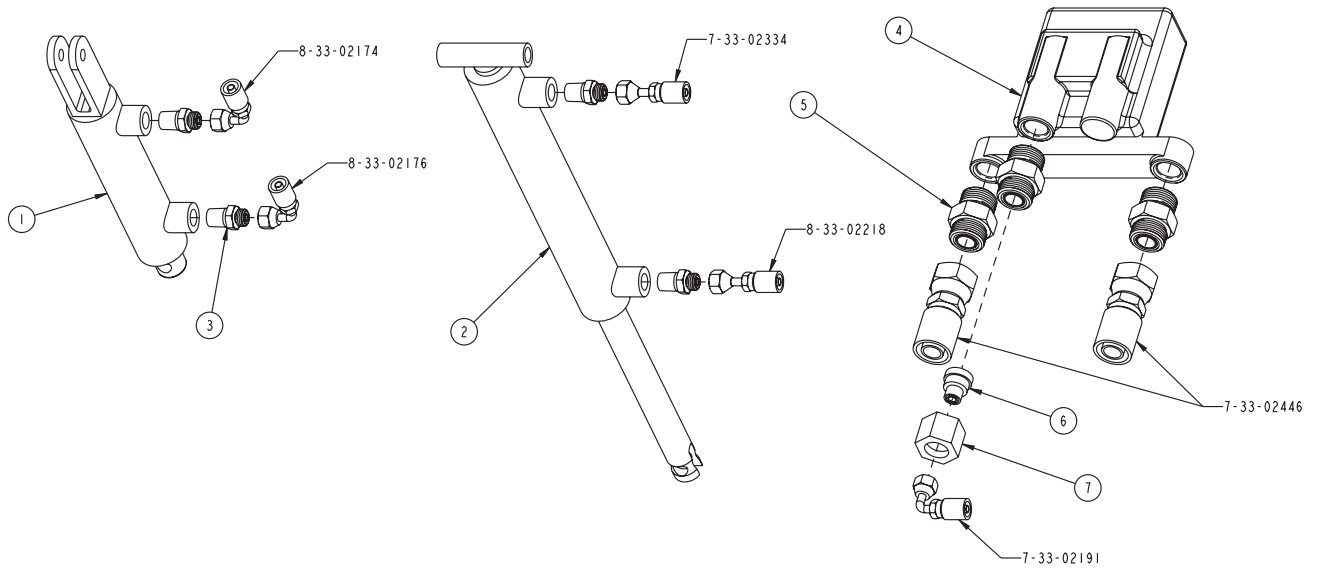

Item	Ref. No.	Qty	Description
1	7-17-05031	1	Cylinder, Squeegee Lift
2	7-17-05009	1	Cylinder, Hydraulic
3	2-00-05054	4	Fitting, 9/16-18 to 3/8-18 Adapter
4	--	1	Tractor Pump Block
5	2-00-05801	3	Fitting, -12 ORS x 22mm SAE Str.
6	2-00-05282	1	Fitting, -12 ORS x -4 ORS, Reducer
7	2-00-05270	1	Fitting, -12 ORS Reducer Nut

HYDRAULIC MOTORS, HOSES & FITTINGS

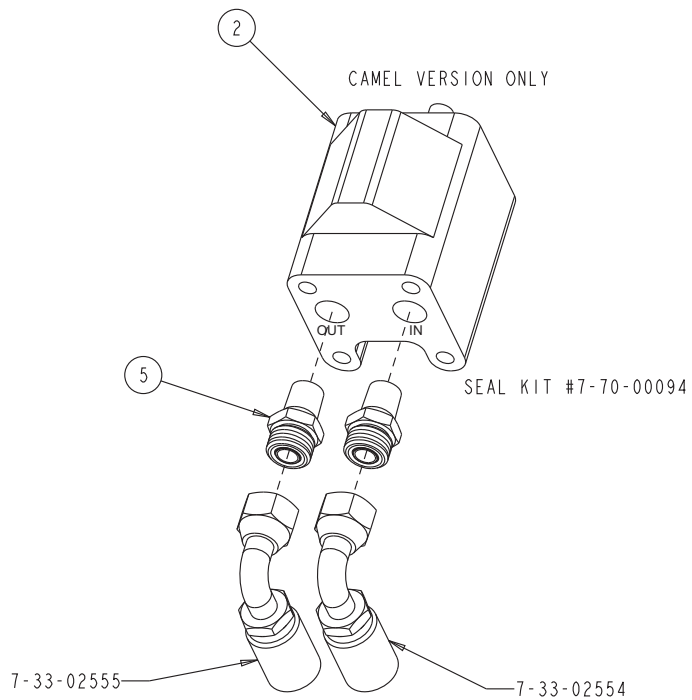
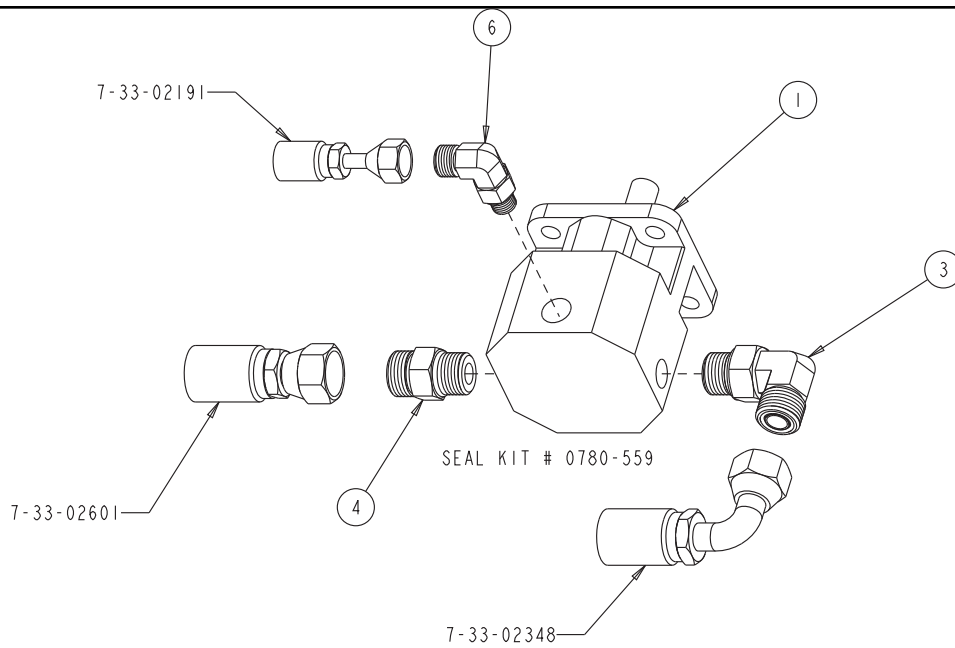

Item	Ref. No.	Qty	Description
1	0782-158	1	Motor, Hydraulic
2	0782-128	1	Motor, Hydraulic
3	2-00-04885	1	Fitting, 90° Elbow (O-Ring)
4	2-00-04970	1	Fitting, Str., -8 ORS x -8 SAE
5	2-00-05195	2	Fitting, -8 ORS x 3/8 NPT Str.
6	2-00-04892	1	Fitting, 90° Elbow (O-Ring)

BRUSH DRIVE MOTORS & FITTINGS

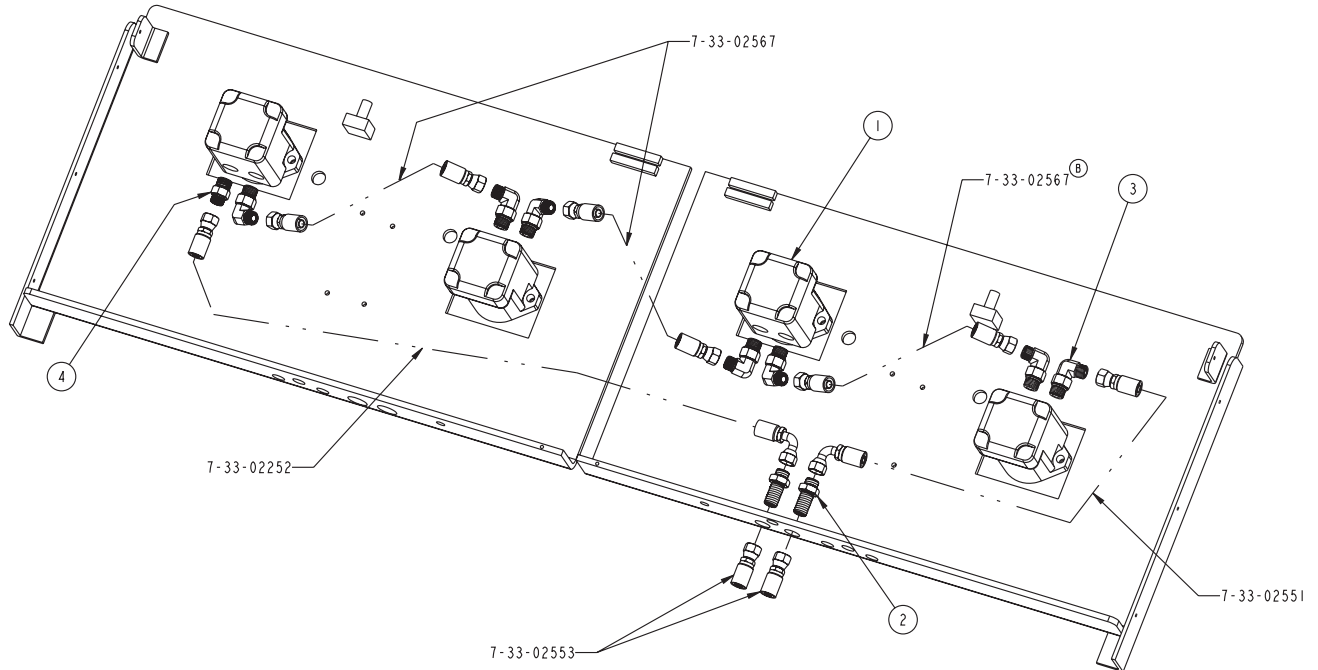

Item	Ref. No.	Qty	Description
1	0782-150	4	Motor, Brush Drive
2	2-00-05802	4	Fitting, -8 ORS Bulkhead, Str.
3	2-00-04921	7	Fitting, 10 SAE 90° -8 ORS
4	2-00-04974	1	Fitting, #8 ORS to #10 SAE Connector

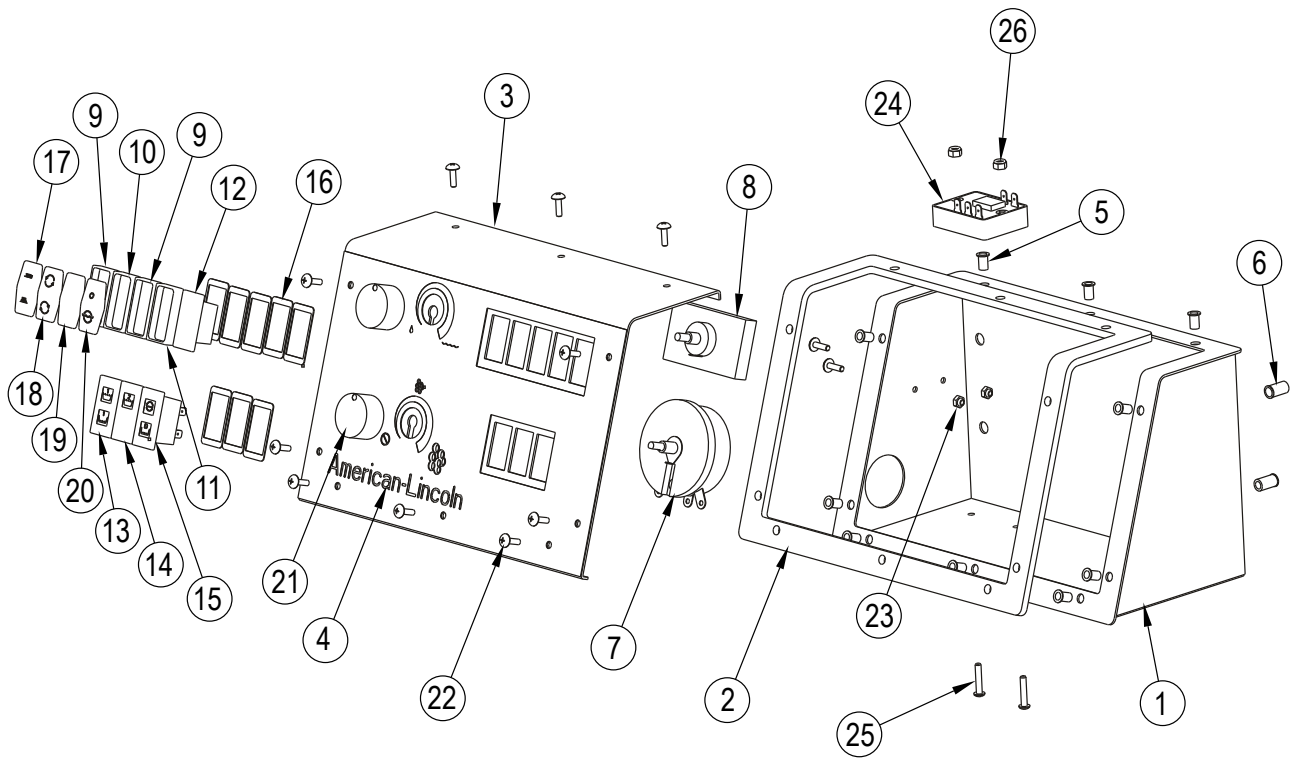

NOTE: FOR NONCAMEL MACHINES REMOVE ITEMS #11 & #20 AND REPLACE WITH AN ADDITIONAL #12. REMOVE ITEMS #7 & #21.

Item	Ref. No.	Qty	Description
1	7-33-05141	1	Housing, Control Panel
2	7-29-00282	1	Gasket, Control Panel
3	7-52-00189	1	Panel, Control
4	8-18-00514	1	Decal, Control Panel
5	2-00-05262	10	Insert, 10-24 Threaded
6	2-00-05261	4	Insert, 1/4-20 Threaded
7	7-64-05013	1	Rheostat, 10 OHM
8	2-00-05912	1	Solenoid Controller (1 Hz, 12 VDC)
9	2-00-05906	2	Switch Base, DPTT (Momentary On) - Off
10	2-00-05741	1	Switch Base, SPDT
11	2-00-05740	1	Switch Base, SPST
12	2-00-05758	1	Cover, Blank Switch
13	2-00-05785	1	Indicator, Tank 1 High/Low Level
14	2-00-05789	1	Indicator, Detergent Low Level/Recovery On
15	2-00-05790	1	Indicator, Tank 2 High Level
16	2-00-05797	8	Gasket
17	2-00-05777	1	Actuator, Scrub Deck Up/Down
18	2-00-05775	1	Actuator, Brush Rotation
19#	2-00-05766	1	Actuator, Squeegee
20	2-00-05778	1	Actuator, Recycle On/Off
21	2-00-05798	2	Knob, Rheostat
22	2-00-03062	12	Screw, 10-24 x 5/8
23	2-00-01372	2	Nut, 8-32 Fiber Lock
24	7-64-00021	1	Timer
25#	2-00-00039	2	Screw, 10-24
26#	2-00-01246	2	Nut, 10-24 Elastic Stop

= Revised or new since last update

DECALS

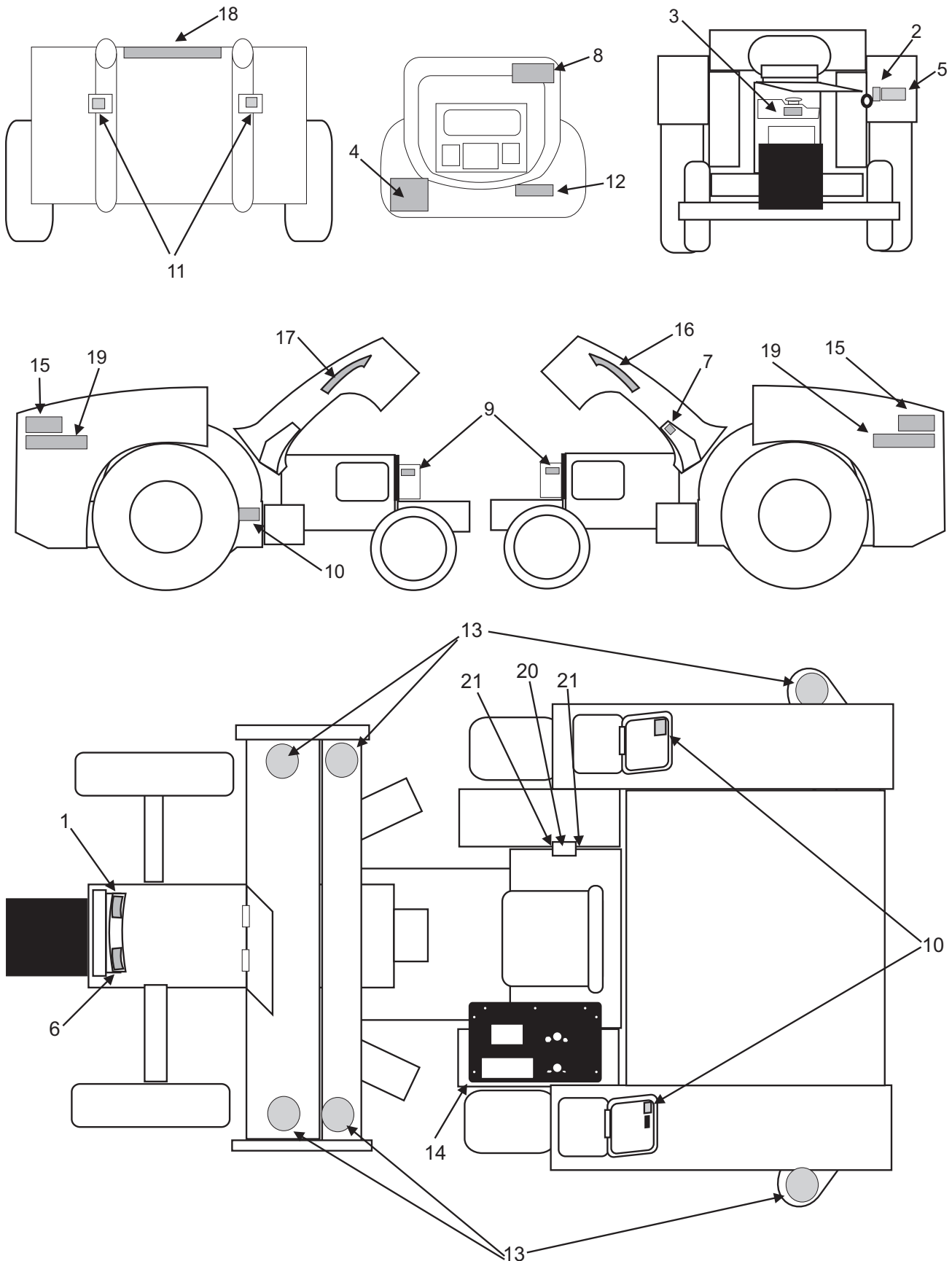

Item	Ref. No.	Qty	Description
1	REF	1	Moving Belts - Stay Clear
2	REF	1	Diesel Fuel Only
3	REF	1	Do Not Remove Radiator Cap
4	REF	1	Do Not Use w/Flammables
5	REF	1	Fire Hazard - Gas Could Explode
6	REF	1	Moving Fan Blade - Stay Clear
7	REF	1	Patent/Patents Pending
8	REF	1	Read Operator's Manual
9	REF	1	Surface Hot - Stay Clear
10	REF	3	No Gasoline or Combustibles NOTE #1
11	8-18-00496	2	Open for Drain Hose
12	REF	1	Turn Off - Lock Wheel
13	REF	6	No Step
14	8-18-00514	1	Instrument Panel
15	8-18-00543	1	SR9772
16	8-18-00564	1	American -Lincoln (LH on Holland TN60) was 8-18-00545 (for Holland TN55)
17	8-18-00563	1	American-Lincoln (RH on Holland TN60) was 8-18-00544 (RH on Holland TN55)
18	8-18-00553	1	American-Lincoln (Large black/gray)
19	8-18-00554	2	American-Lincoln (Medium black/gray)
20	REF	1	Serial Number Plate
21	8-18-04115	2	Rivet

NOTE #1: Camel Version Only: Qty. 4 (1 on detergent tank)

WARNING DECAL KIT: 0760-902

SCRUB DECK HYDRAULICS & FITTINGS

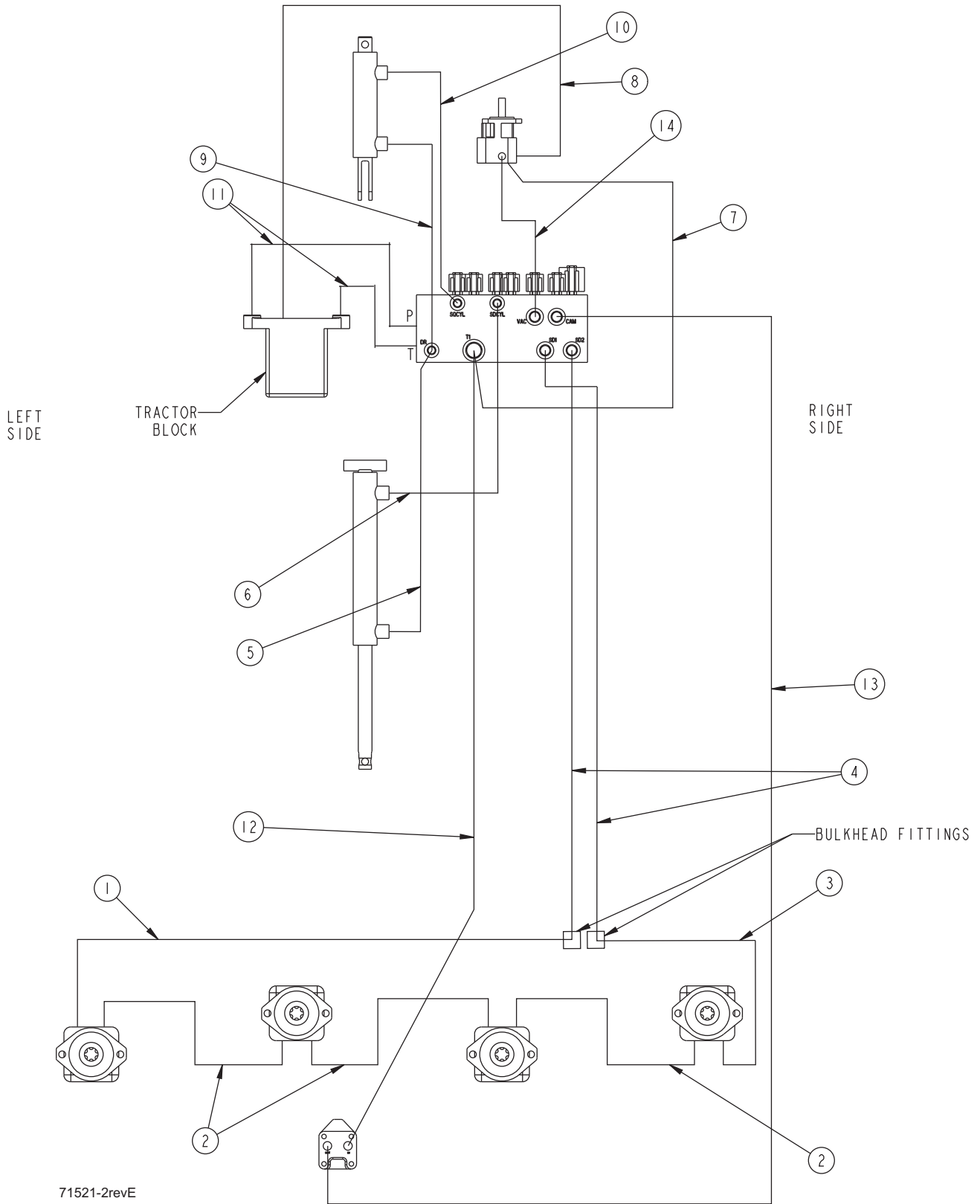

SCRUB DECK HYDRAULICS & FITTINGS

Item	Ref. No.	Qty	Description
1	7-33-02551	1	Hose, -8 ORS, STR x 90, 35" long
2	7-33-02567	3	Hose, -8 ORS, STR, 15.5" long
3	7-33-02252	1	Hose, -8 ORS, STR x 90, 47" long
4	7-33-02553	2	Hose, -8 ORS, STR, 90" long
5	7-33-02334	1	Hose, #4 ORS, STR - 90, 47.5" long
6	8-33-02218	1	Hose, #4 STR - STR, 9/16-18 both ends, 90" long
7	7-33-02348	1	Hose, -8 ORS, STR - 90, 32" long
8	7-33-02191	1	Hose, #4 STR - 90, 9/16-18 both ends, 42" long
9	8-33-02174	1	Hose, -4 ORS, STR x 90, 16.5" long
10	8-33-02176	1	Hose, -4 ORS, STR x 90, 20" long
11	7-33-02446	2	Hose, -12 ORS, STR x 90, 22.5" long
12	7-33-02554	1	Hose, -8 ORS, STR x 90, 113.5" long NOTE #1
13	7-33-02555	1	Hose, -8 ORS, STR x 90, 116" long NOTE #1
14	7-33-02601	1	Hose, #8 STR, 23" long

NOTE #1: Not part of Hose Kit 0760-673

SCRUB DECK FLAP ASSEMBLIES

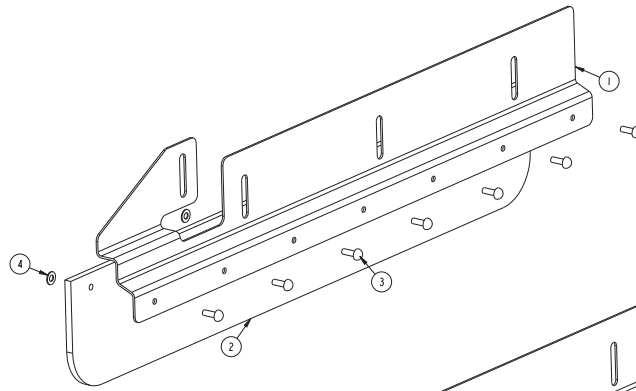

LEFTHAND
7-25-08097

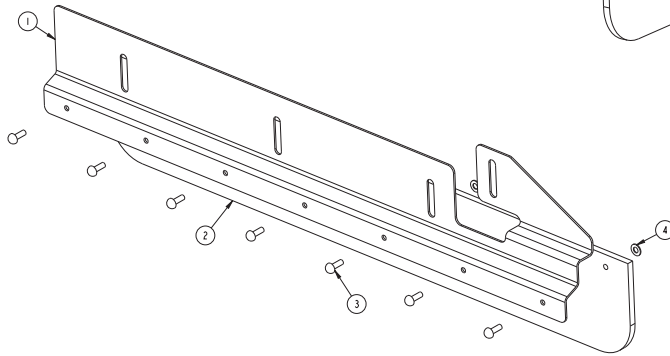
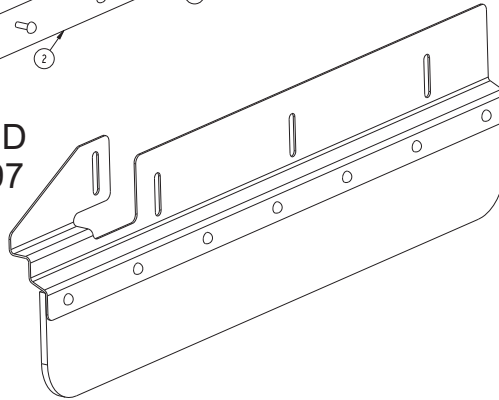

RIGHTHAND
7-25-08098

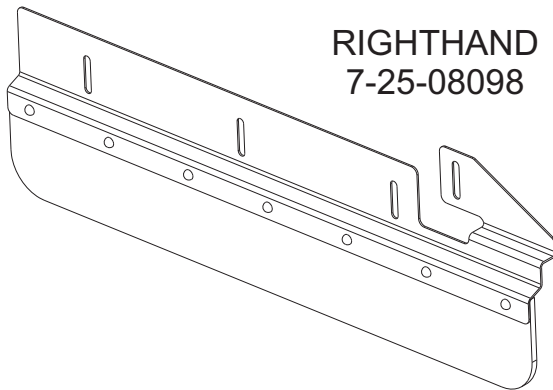

Item	Ref. No.	Qty	Description
1	7-32-03023	1	Holder, Flap, LH
	7-32-03025	1	Holder, Flap, RH
2	7-25-08096	2	Flap, Side
3	2-00-04811	14	Rivet, 1/4" Blind
4	2-00-00466	14	Flat Washer, .625 x .203 x .031

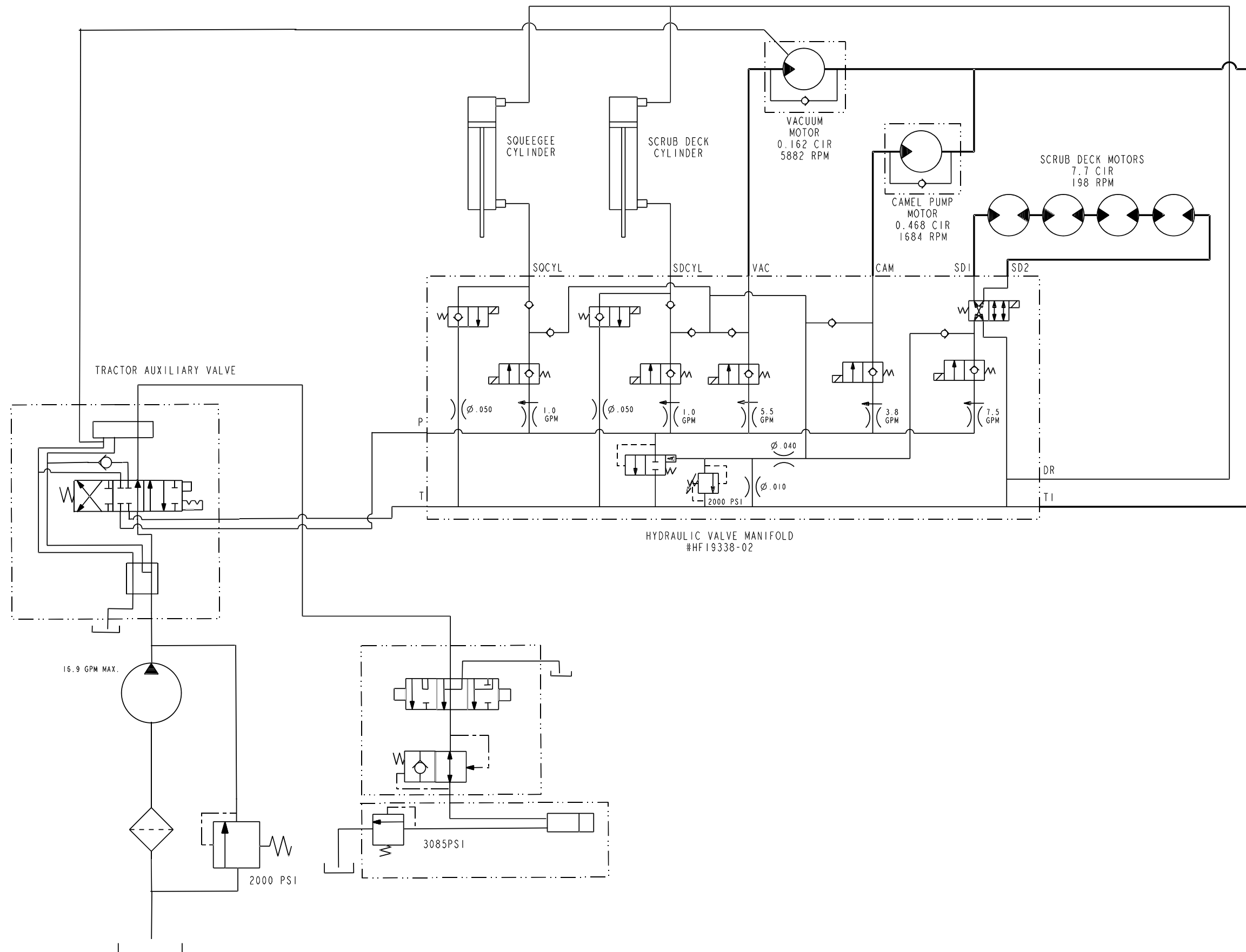

ELECTRICAL SCHEMATIC

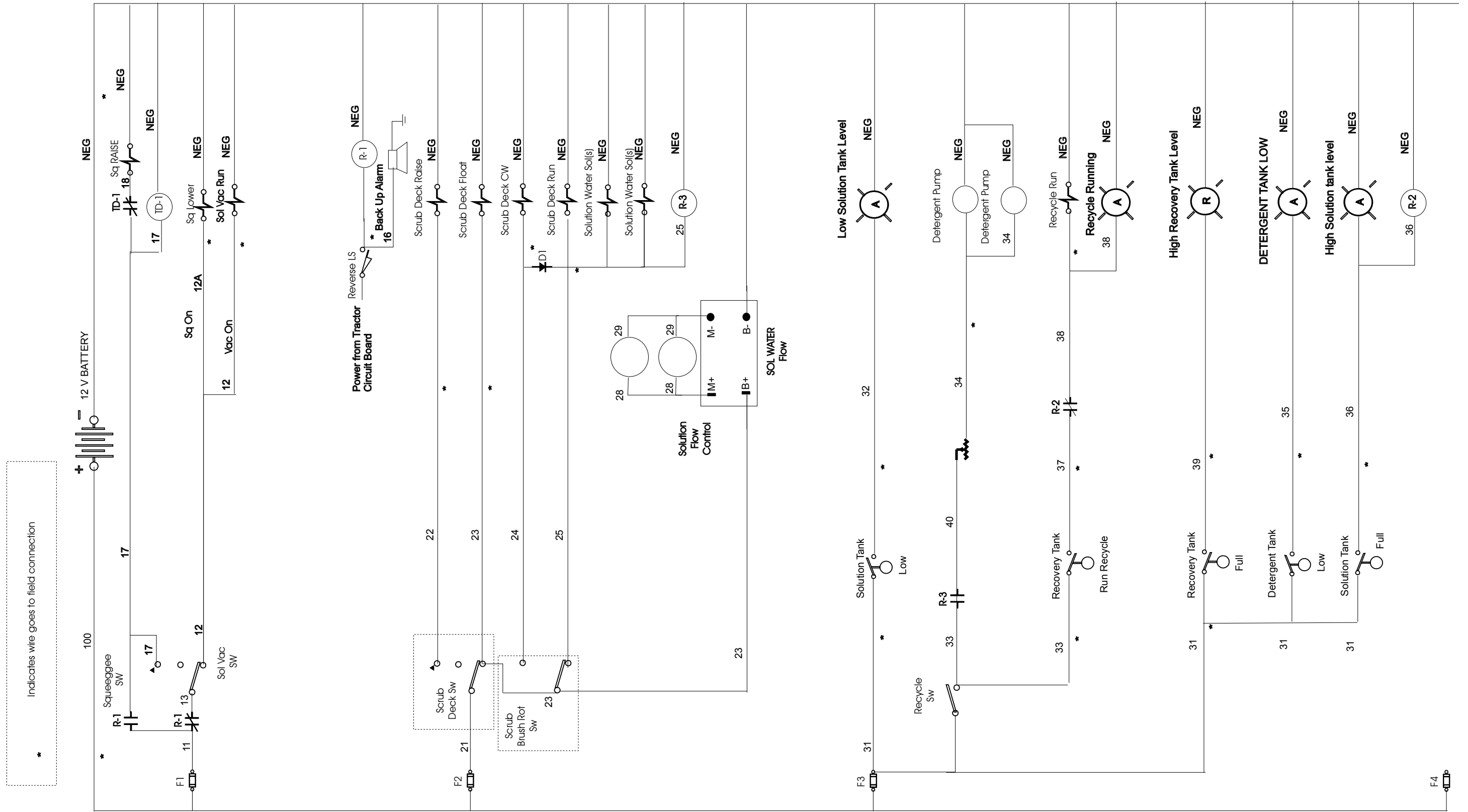
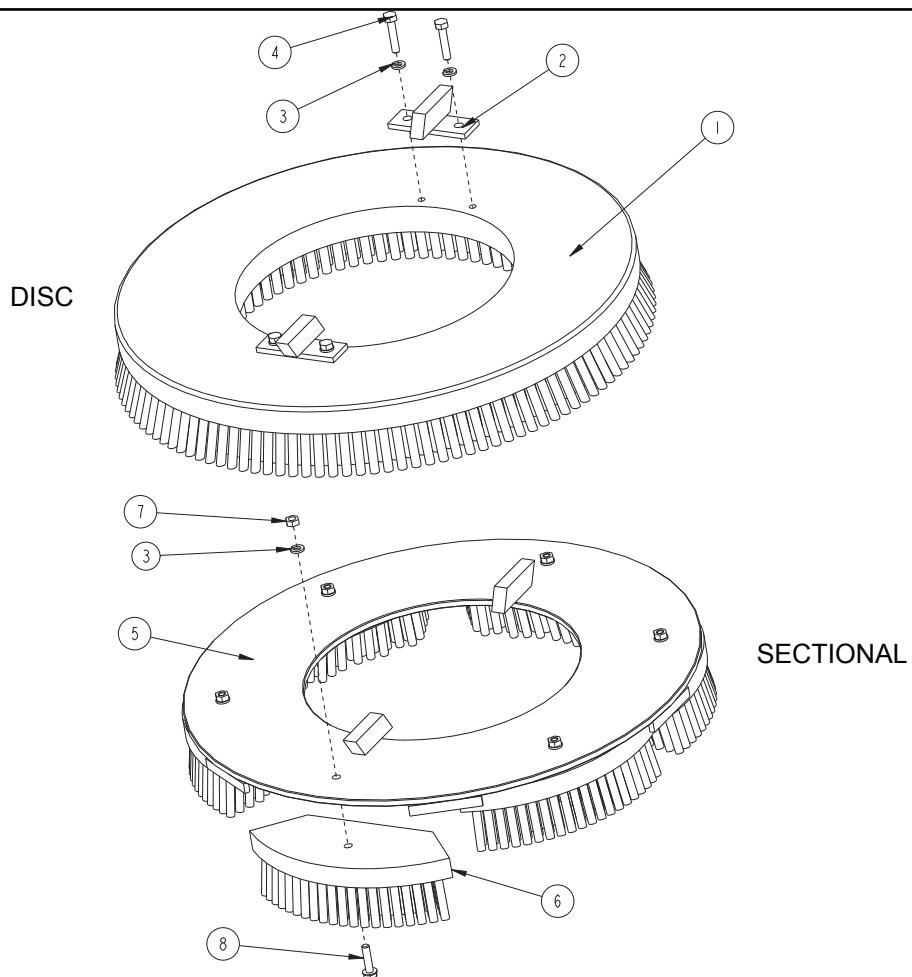

TABLE OF CONTENTS - CHAPTER 3 - OPTIONS

Brush Options.....	3-2
Foam-Filled Tires Option	3-3
Catalytic Muffler Option	3-4
Rotating Light Option (ROLL-BAR)	3-5
Warning Light Option (CAB)	3-6
Vacuum Wand Option.....	3-7
Transmission Lock-Out Option	3-8
Additional Options	3-9

BRUSH OPTIONS



Item	Ref. No.	Qty	Description
1	7-08-03173-1	1	Straight Wire, 18"
1	7-08-03191-1	1	Wire/ Amerifil, 18"
1	7-08-03205-1	1	Supergrit, 18"
1	7-08-03170-1	1	Nylon, 18"
1	7-08-03172-1	1	Amerifil, 18"
1	7-08-03262-1	1	Soft Nylon, 18"
1	7-08-03269-1	1	Cleangrit, 18"
2	7-45-05026	2	Lug
3	2-00-00518	10	Lock Washer, 1/4" Helical Spring
4	2-00-02587	4	Cap Screw, Hex Head, .25-20 x 1.25
5	7-58-05182	1	Plate, Brush Mounting
Sectional Brushes (plastic back)			
6	7-08-03192	6	Bassine
6	7-08-03193	6	Straight Wire
6	7-08-03194	6	Nylon (Black)
6	7-08-03195	6	Amerfil (.025)
6	7-08-03196	6	Amerfil (.040)
6	7-08-03197	6	Amergrit
7	2-00-00594	6	Nut, Hex 1/4 - 20
8	2-00-02706	6	Screw, 1/4 - 20 x 1.00 HHM

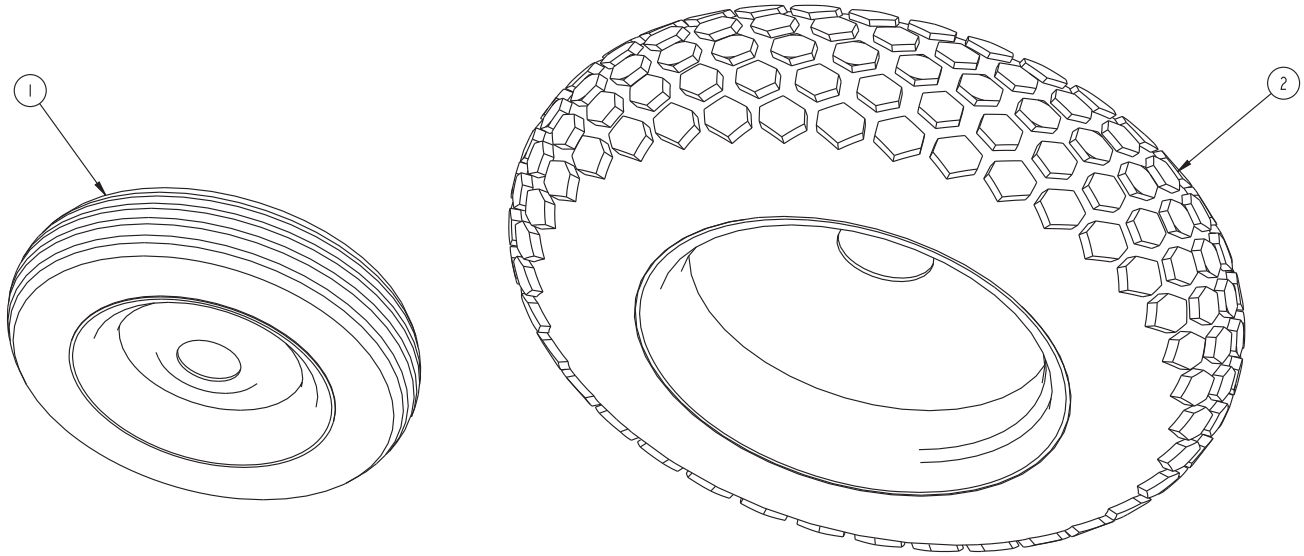

OPTION NO. 0780-550

Item	Ref. No.	Qty	Description
1	0797-050	2	Foam Filled Front Tire
2	0797-021	2	Foam Filled Rear Tire

CATALYTIC MUFFLER OPTION

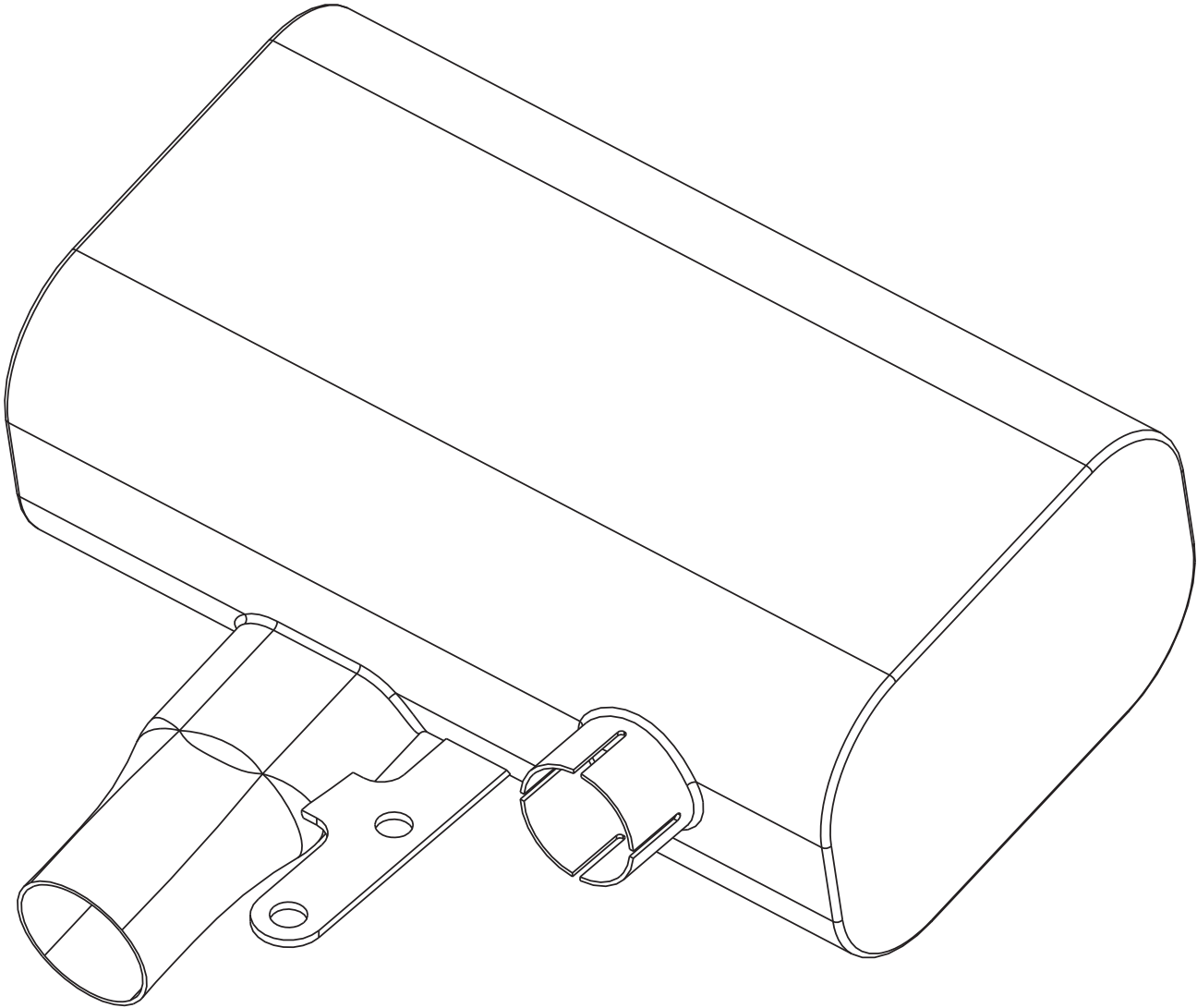

OPTION NO. 0780-531

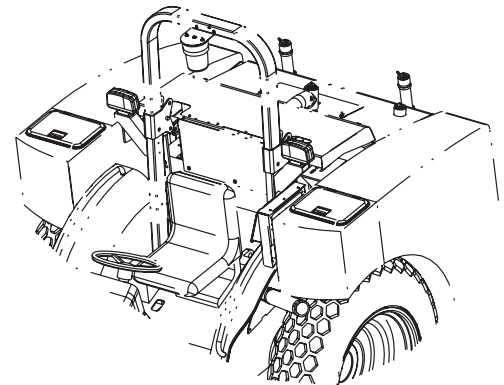
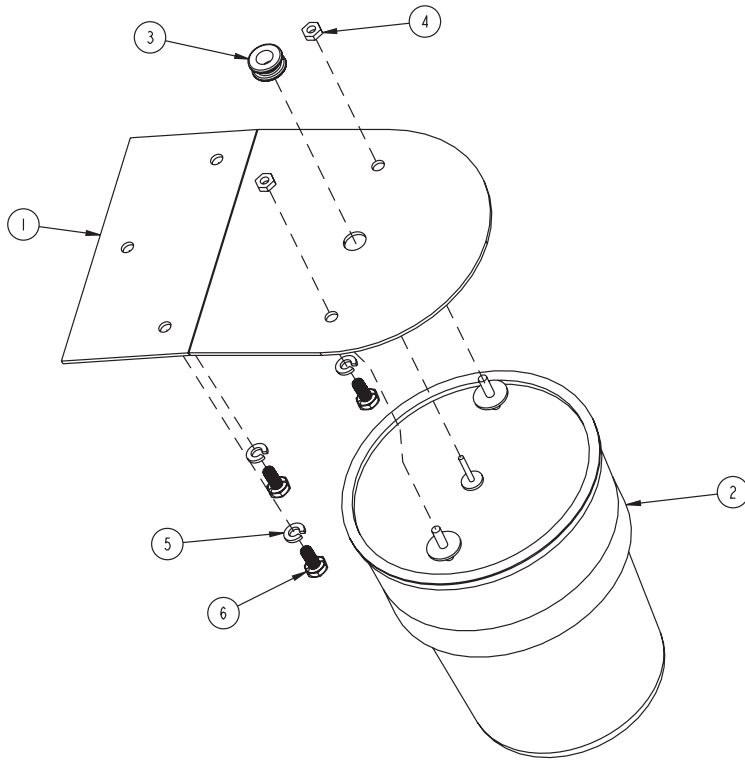

OPTION NOS. 0780-533 (RED) & 0780-536 (AMBER)

Item	Ref. No.	Qty	Description
1	7-08-02034	1	Bracket, Warning Light, Roll Bar
2	8-40-05033	1	Warning Light, Revolving (RED)
	8-40-05039		Warning Light, Revolving (AMBER)
3	2-00-00491	1	Grommet
4	2-00-00605	2	Hex Nut, 10-24
5	2-00-00518	3	Lock Washer, 1/4" Helical Spring
6	2-00-00251	3	Screw, 1/4-20 x .50

WARNING LIGHT OPTION (CAB)

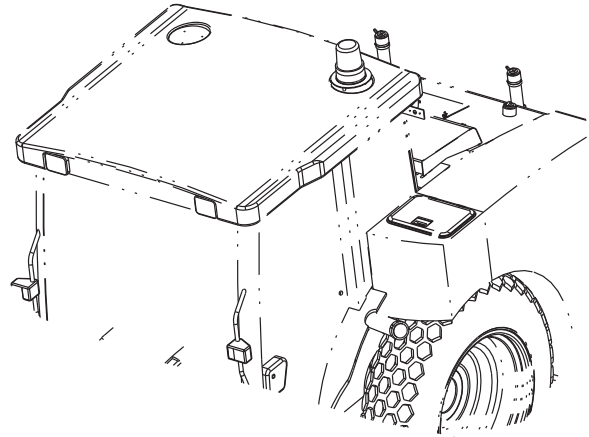
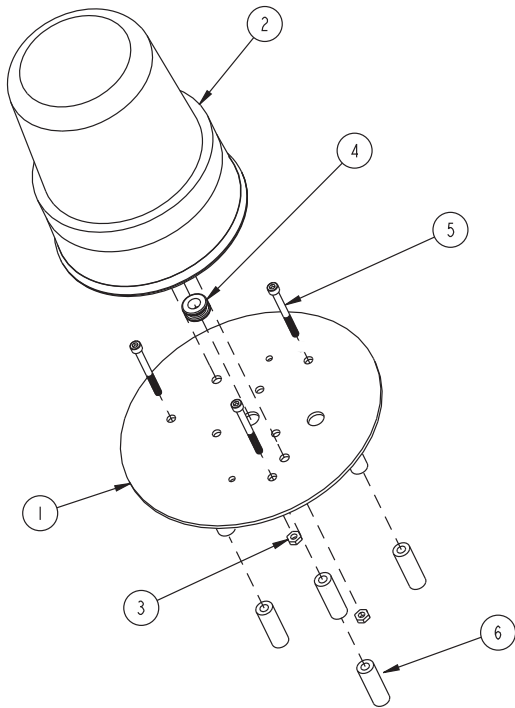

OPTION NOS. 0780-535 (RED) & 0780-538 (AMBER)

Item	Ref. No.	Qty	Description
1	8-89-07600	1	Support, Warning Light
2	8-40-05033	1	Warning Light, Revolving (RED)
	8-40-05039		Warning Light, Revolving (AMBER)
3	2-00-00605	2	Hex Nut, #10-24
4	2-00-00491	1	Grommet
5	2-00-05823	3	Screw, M6 x 1.0 x 55mm Pan Head
6	7-09-01062	6	Spacer

VACUUM WAND OPTION

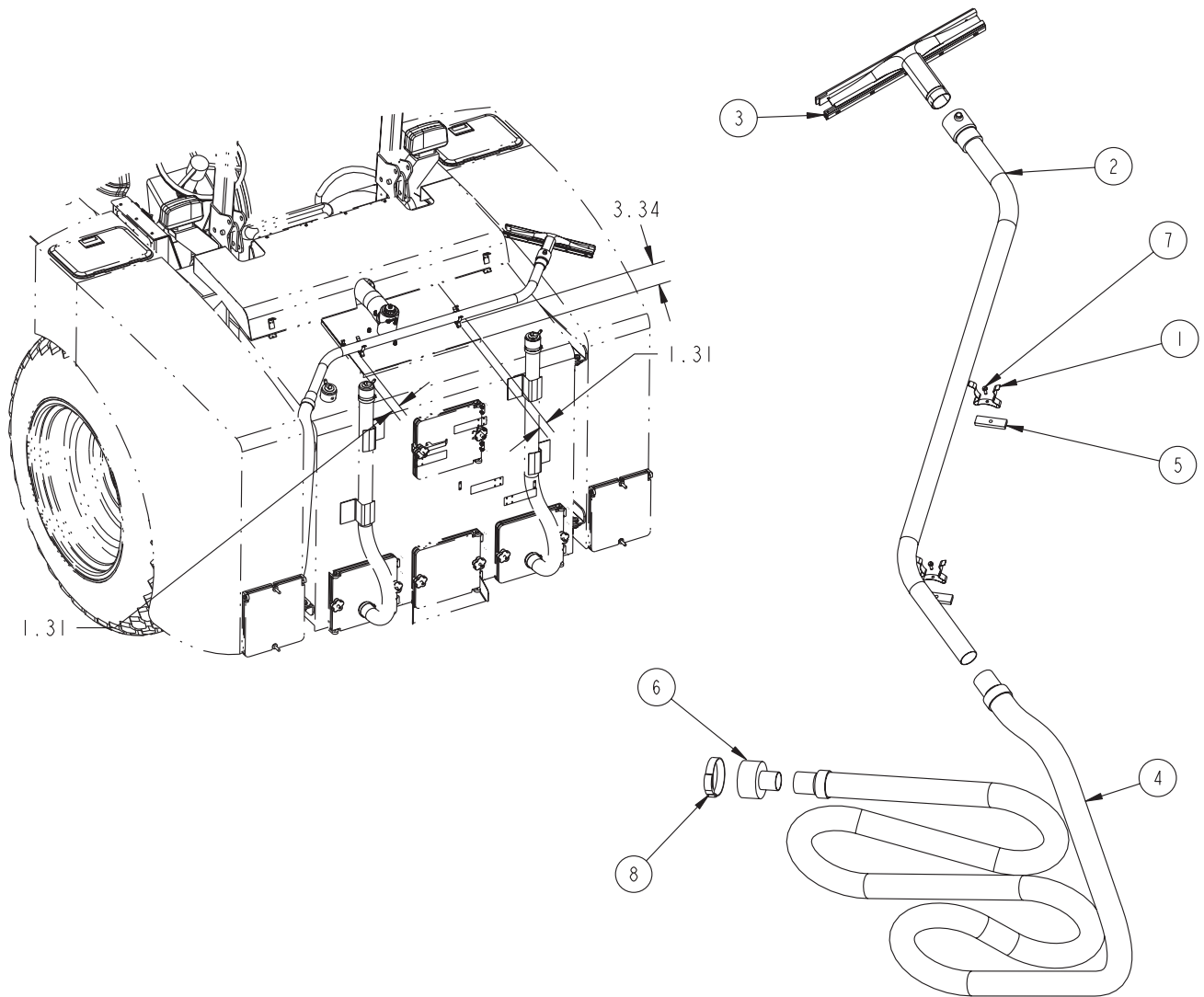

OPTION NO. 0780-539

Item	Ref. No.	Qty	Description
1	7-13-07097	3	Clip, Tool
2	639804	1	Wand Assembly
3	638824	1	Tool Assembly
4	7-33-02213	1	Hose, Vacuum
5	2-00-05905	2	Spacer
6	7-03-00040	1	Adapter, 3" OD - 1.5" OD
7	2-00-04312	2	Screw, 10-24 x .63 HWH
8	7-13-07225	1	Clamp, Over-Center Hose, 3"

TRANSMISSION LOCK-OUT OPTION

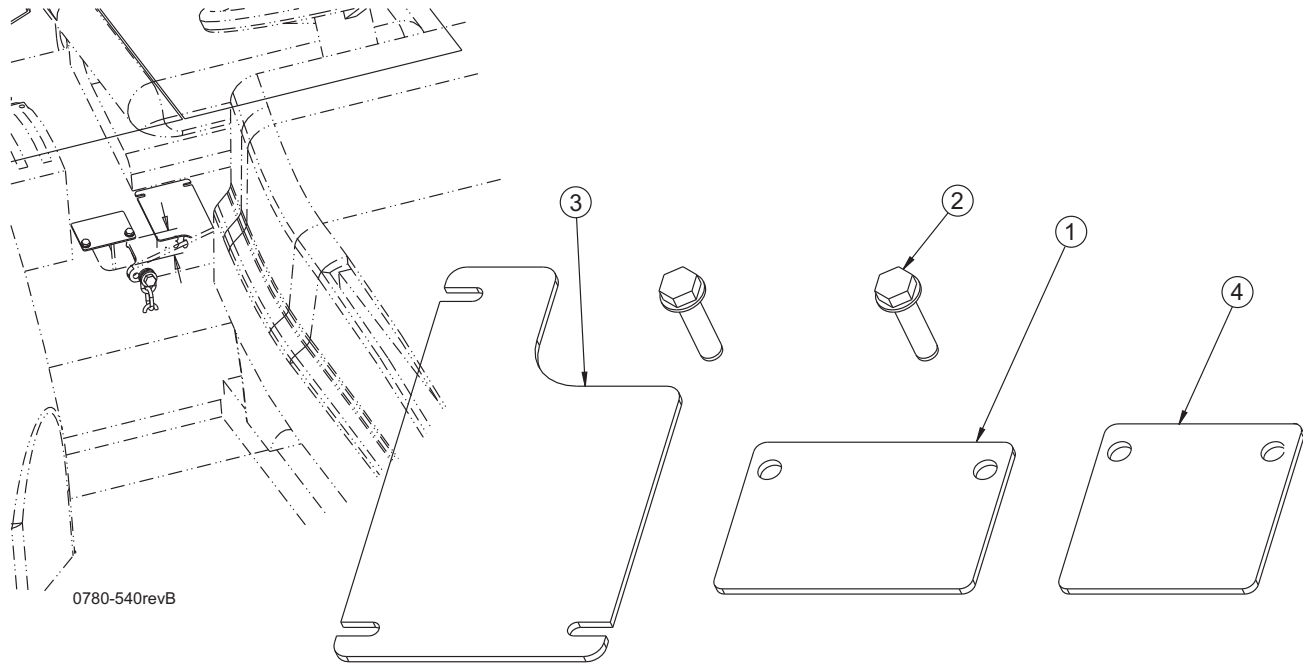

OPTION NO. 0780-540

Item	Ref. No.	Qty	Description
1	7-08-02037	1	Bracket, Transmission Lock-Out
2	2-00-05315	2	Screw, Self-Drill 1/4-14 X .1.00 LG
3	7-58-05357	1	Plate, Transmission Lockout
4	7-58-05358	1	Bracket, Transmission Lockout

Item	Ref. No.	Qty	Description
**#	56109256	A/R	Options High Temp, Low Pressure Option

= Revised or new since last update

American-Lincoln®

14600 21st Avenue North
Plymouth, MN 55447-3408
www.americanlincoln.com
Phone: 800-331-7692
Fax: 877-877-2586
©2007 American-Lincoln