



Electronic Service Manuals

This electronic document is provided as a service to our customers. We do not create the contents of the information contained in this document. Should you have detailed questions pertaining to the information contained in this document, you may contact Michco, or the manufacturer which provided the original information in this electronic deliverable. Michco's only part in this electronic deliverable was the electronic assembly process. By providing this manual on line we are not guaranteeing parts availability.

You may contact Michco through the following methods:

Phone (517) 484-9312 or (800) 331-3339

2011 N. High St. -- Lansing, Michigan -- 48906

Fax: (517) 484-9836

Email: CustServe@Michco.com

Web site: www.Michco.Com

Parts Web site: www.FloorMachineParts.Com

Order Parts on Line at:

www.FloorMachineParts.Com

Directly to Parts & Service:

By Email: **Shop@Michco.com**

By Fax: (517) 702-2041

By Voice: Use numbers above.

Serving the Cleaning Industry Since 1922

Notice: All copyrighted material remains property of original owners, all trademarks are property of respective owners. Manuals are subject to Manufacturer's reproduction limitations. Originals or reproductions were provided by manufacturers through a request. We make no warranty as to the correctness of information provided in this document and you assume all risk. By placing these manuals on line we are not declaring our corporation to be an manufacturer authorized dealer or provider, please check our web site for authorized manufacturers we represent.

SW8000



Service Manual

Advance Model Numbers:

56107501	65" Gasoline
56107503	65" LPG
56107505	65" Diesel
56107507	65" Gasoline w/ cab
56107509	65" LPG w/ cab
56107511	65" Diesel w/ cab

Nilfisk Model Numbers:

56107512	165 cm LPG
56107513	165 cm Diesel
56107514	165 cm LPG w/ cab
56107515	165 cm Diesel w/ cab
56107517	165 cm Petrol



English

Contents

General Information	9
General Machine Description	9
Service Manual Purpose and Application	9
<i>Introduction</i>	9
Revision History	9
Other Reference Manuals and Information Sources.	9
<i>Nilfisk-Advance Publications</i>	9
Engine Manufacturers’ Technical Manuals	10
Parts And Service.	10
Name Plate	10
General Safety Instructions	11
Hopper Safety Support.	13
Jacking The Machine	14
Transporting The Machine.	15
Towing Or Pushing A Disabled Machine	16
Technical Specifications	17
Fastener Torque Specifications	19
Maintenance	20
<i>Maintenance Schedule</i>	20
<i>After Use</i>	20
<i>To Shut Down The Diesel / Gasoline Engine</i>	21
<i>To Shut Down The Propane Engine</i>	21
<i>Important Machine Lubrication</i>	21
<i>Engine Coolant</i>	22
<i>Engine Oil – Gasoline / Petrol & Lpg</i>	22
<i>Engine Oil - Diesel</i>	22
<i>Engine Air Filter</i>	23
<i>Engine Maintenance (150 Hours)</i>	23
<i>Hydraulic Oil</i>	23
<i>Hopper Dust Control Filter (Panel Filter).</i>	24
<i>To remove the hopper dust control filter....</i>	24
<i>Method “A”</i>	24
<i>Method “B”</i>	24
<i>Method “C”</i>	24
SW8000 PM Checklist	25
Know Your Machine	27
<i>Operator’s Compartment</i>	29
<i>Control Panel</i>	30

Control System	31
Functional Description	31
<i>Control Panel</i>	31
<i>Main Machine Controller</i>	34
Component Locations	35
Main Machine Controller Programming	36
<i>Hydrostatic Neutral Position and Dead-band</i>	36
<i>Recall of Stored Fault Codes</i>	36
<i>Automatic Shaker Operation</i>	37
Troubleshooting	37
<i>Main Controller Error Codes</i>	37
Removal and Installation.	39
<i>Main Control Board</i>	39
Specifications	40
<i>Sample Shop Voltage Measurements</i>	40
Dust Control System	42
Functional Description	42
<i>DustGuard™ Spray System (optional)</i>	42
<i>Dust Control Vacuum System</i>	42
<i>Circuit Description</i>	42
<i>Simplified Schematic Diagram</i>	43
Component Locations	44
Maintenance and Adjustment.	45
<i>Dustguard Spray Nozzle Cleaning</i>	45
<i>Dust Control Filter Cleaning</i>	45
Troubleshooting	46
<i>Dust Control Vacuum Motor will not Run</i>	46
<i>Dust Control Vacuum Motor will not Shut Off.</i>	47
<i>Shaker Motor will not Run</i>	48
<i>Misting Pump will not Run</i>	49
Specifications	50
Electrical System	51
Functional Description	51
<i>Overview</i>	51
<i>Gauge Panel Assembly</i>	51
<i>Circuit Breaker Panel Assembly.</i>	52
<i>Wire Identification.</i>	53
<i>Rotary Sensor</i>	53
<i>Seat Switch Circuit Description</i>	54
Component Locations	55
<i>Battery</i>	55
<i>Instrument Panel Assembly.</i>	56
<i>Circuit Breakers</i>	56
<i>SPDT Relays</i>	57
<i>K11 Seat Relay Coil and K12 Timer Relay (seat switch option only)</i>	57
<i>S22 Brake Switch (seat switch option only)</i>	58
<i>Rotary Sensor</i>	58
Electrical Connectors.	59
<i>Component to Connector ID Look-up Table</i>	59

Component to Relay ID Look-up Table	60
Connector Pin-out Assignments	60
Troubleshooting	67
Specifications	67
Wiring Diagrams, p/n 56382530, Rev. D	68
Wiring Diagram, Kubota Gasoline Engine, p/n 56107658, Rev. A.	71
Wiring Diagram, Kubota LP Engine, p/n 56107659, Rev. A.	72
Wiring Harness Diagrams, p/n 56382531 Rev. D.	73
Engine System, Diesel	76
Functional Description	76
Overview	76
Engine Description.	76
Manufacturers' Technical Literature.	77
Engine Starter Circuit	77
Starter Circuit Description	77
Engine Protection – Low Oil Pressure Shutdown	78
Engine Speed Control	78
Glow Plug Control	79
Component Locations	80
Maintenance and Adjustments	82
Maintenance Schedule	82
Engine Oil	83
Engine Coolant.	83
Checking Engine Coolant	83
Replacing Engine Coolant	84
Engine Air Filter Maintenance	85
Replacing the Fuel Filter	85
Bleeding the Fuel System	86
Troubleshooting	89
General Troubleshooting	89
Engine Overheating Problems	90
Loss of Oil Pressure	90
APECS 3000 Controller Fault Codes	90
Compression Test	91
Specifications	93
Special Tools	94
Engine System, Gasoline/LPG	96
Functional Description	96
Overview	96
Engine Description.	96
Kubota 1.6L Gasoline Fuel System Description	96
Kubota 1.6L LPG Fuel System Description	96
Engine Starter Circuit Description	97
Engine Protection – Low Oil Pressure Shutdown	98
Engine Protection – High Temperature	98
Engine Speed Control	98
Component Locations	99
LPG And Gasoline Engine Common Electrical Components	99
LPG ONLY Engine Electrical and Fuel Components	102
Gasoline (Petrol) ONLY Engine Electrical and Fuel Components	103

Maintenance and Adjustments	104
<i>Maintenance Schedule</i>	104
<i>Engine Oil</i>	105
<i>Engine Coolant</i>	105
<i>Checking Engine Coolant</i>	105
<i>Replacing Engine Coolant</i>	106
<i>Engine Air Filter Maintenance</i>	107
Troubleshooting	107
<i>General Troubleshooting</i>	107
<i>Engine Overheating Problems</i>	108
<i>Shop Measurements</i>	110
<i>Engine Vacuum</i>	110
Special Tools	111
Hopper System	112
Functional Description	112
<i>Overview</i>	112
<i>Hopper</i>	112
<i>Hopper Door</i>	113
<i>Hopper Hydraulic System</i>	114
Hopper System Wiring Diagram.	115
Hopper System Circuit Description	116
Hopper System Hydraulic Diagrams.	117
<i>Hopper Down, Hopper Door Closed</i>	117
<i>Raise Hopper</i>	118
<i>Lower Hopper</i>	119
<i>Open Hopper Door</i>	120
<i>Close Hopper Door</i>	121
Component Locations	122
<i>Hopper</i>	122
<i>Hopper Interlock Switch</i>	122
<i>Hopper Lift Cylinder</i>	123
<i>Hopper Prop Rod</i>	123
<i>Hopper Door Cylinder</i>	124
<i>Hydraulic Manifold Assembly and Solenoid Valves</i>	124
Troubleshooting	125
Specifications	127
Hydraulic System	128
Functional Description	128
<i>Overview</i>	128
<i>Hydraulic Pumps</i>	129
<i>Hydraulic Manifold Assembly</i>	129
<i>Electrical Schematic</i>	130
<i>Electrical Circuit Description</i>	130
Component Locations	131
<i>Hydraulic Piston and Gear Pumps</i>	131
<i>Hydraulic Manifold Assembly</i>	131
<i>Hydraulic Oil Reservoir</i>	132
<i>Oil Filter</i>	132
<i>Oil Cooler</i>	133
Maintenance and Adjustments	133

<i>To Check the Hydraulic Oil Level</i>	133
<i>To Change the Hydraulic Oil Filter</i>	134
<i>To Clean the Hydraulic Oil Cooler</i>	134
Troubleshooting	135
<i>General Troubleshooting</i>	135
<i>General Information Regarding Checking Hydraulic Pressures</i>	135
<i>Checking the Gear Pump Pressure</i>	136
<i>Checking the Piston Pump Pressure</i>	137
<i>Hydraulic Truth Table</i>	137
Specifications	138
<i>General Specifications</i>	138
<i>Hydraulic Manifold Assembly</i>	139
Special Tools	140
Hydraulic Schematic, 56507055, Rev. N	141
Options and Accessories	142
SW8000 Deluxe Cab Options	152
<i>Technical Specifications</i>	152
<i>Cab Controls</i>	153
<i>Heating System Components</i>	154
<i>Air Conditioning System Components</i>	155
<i>Maintenance</i>	156
<i>Maintenance Schedule</i>	156
<i>To Clean and Replace the Cab Filter</i>	156
Heating System	157
<i>General System Overview</i>	157
<i>Electrical Circuit Overview</i>	157
<i>Heater Blower Motor</i>	157
<i>Heater Temperature Control</i>	157
<i>Electrical Troubleshooting</i>	158
<i>To Troubleshoot the Heater Temperature Control</i>	160
<i>To Eliminate Air Locks from the Cooling System</i>	161
<i>Cooling System Vacuum Filler</i>	161
<i>Purge the Heater Circuit</i>	161
Air Conditioning System	162
<i>General System Overview</i>	162
<i>Electrical Circuit Overview</i>	162
<i>Condenser Fan, Thermostat, Pressure Switch and Compressor Motor</i>	163
<i>Electrical Troubleshooting</i>	164
<i>Component Troubleshooting</i>	166
<i>Accessory (Gear) Hydraulic Pump</i>	167
<i>Compressor Relay (K10)</i>	167
<i>Binary Pressure Switch (S34)</i>	168
<i>Thermostat (S33)</i>	170
Heating and A/C System Plumbing and Hydraulic Flow Schematic.	172

Steering System	173
Functional Description	173
<i>Overview</i>	173
Hydraulic Diagrams	175
<i>Steering Control Unit Description</i>	175
<i>Steering Wheel Stationary</i>	176
<i>Steering Wheel Turned Toward the Right</i>	177
<i>Steering Wheel Turned Toward the Left</i>	178
<i>Steering Wheel Held in Full Right or Left Position</i>	179
<i>Turning the Steering Wheel with the Engine Off</i>	180
Component Locations	181
<i>Steering Wheel and Steering Control Unit</i>	181
<i>Steering Cylinder</i>	181
Maintenance	182
Troubleshooting	183
Specifications	183
Sweep System, Main Broom	184
Functional Description	184
<i>Circuit Description</i>	184
<i>Hydraulic Operation</i>	185
Component Locations	186
Maintenance and Adjustment	187
<i>Cleaning and Inspecting the Main Broom</i>	187
<i>Rotate or Replace the Main Broom</i>	187
<i>Inspect and Adjust the Broom Height</i>	188
<i>Inspect Housing Skirts</i>	188
Troubleshooting	189
<i>Main Broom Motor Will Not Run</i>	189
Specifications	190
Sweep System, Side Broom	191
Functional Description	191
<i>Circuit Overview</i>	191
<i>Electrical Circuit</i>	192
<i>Hydraulic Circuit, Brooms Off</i>	192
<i>Hydraulic Circuit, Brooms On</i>	193
Component Locations	194
Troubleshooting	195
<i>Side Broom Won't Run</i>	195
<i>Side Broom Won't Raise</i>	196
<i>Side Broom Won't Lower</i>	196
Specifications	196
Wheel System, Non-Traction	197
Functional Description	197
Maintenance and Adjustments	197
Troubleshooting	197
Removal and Installation	197
<i>To Remove and Reinstall a Wheel</i>	197
<i>To Remove and Reinstall a Brake and Spindle Assembly</i>	198

Wheel System, Traction	199
Functional Description	199
<i>Overview</i>	199
<i>Piston (drive) Pump and Drive Motor</i>	199
<i>Foot Pedal Assembly</i>	200
<i>Forward/Reverse Controls</i>	200
<i>Rear Wheel Assembly</i>	201
Electrical Schematic and Circuit Description	201
Hydraulic Diagrams.	202
<i>Drive Motor in Neutral</i>	202
<i>Tow Valve in Bypass Position</i>	202
<i>Drive Motor in Forward or Reverse</i>	203
<i>Drive Motor Stalling Out</i>	204
Component Locations	205
<i>Piston (drive) Pump and Tow Valve</i>	205
<i>Drive Motor and Rear Wheel Assembly</i>	205
<i>Foot Pedal Assembly</i>	206
<i>Forward/Reverse Controls</i>	206
Adjustments	207
<i>To Set the Drive Pump Neutral Position</i>	207
Troubleshooting	208
Specifications	208

General Information

General Machine Description

The SW8000 machine is an industrial power rider broom sweeper. Gasoline (Petrol), LPG and diesel engine models are available, with or without the DustGuard™ option. The machine is hydraulic powered and electrically controlled. The sweep system has a center main broom and a right-hand side brooms. A left hand side broom is available as an option.

Service Manual Purpose and Application

This Service Manual is a technical resource designed to aid service personnel in maintaining and repairing the SW8000 Sweeper to ensure optimum performance and long service life. Please read it thoroughly before servicing your machine.

Introduction

This manual will help you get the most from your Advance rider Scrubber-Sweeper. Read it thoroughly before servicing the machine. Refer to the “Know Your Machine” section for component locations discussed in this chapter.

This product is intended for commercial use only.

Revision History

Revision Date	Description
11/13	• Replaced Hydraulic Schematic 56507055 Rev M with Rev. N
08/14	• Engine System, Gasoline, LPG, Special Tools - Add Part Number for Kubota Engine software CD

Other Reference Manuals and Information Sources

Nilfisk-Advance Publications

Model Name	Model Number	Instructions for Use Form Number	Parts List Form Number
Advance SW8000 4 Cylinder LPG	56107503	56091065: English, Spanish, French, Portuguese	56042600 56042602
Advance SW8000 4 Cylinder Gasoline / Petrol	56107501		
Advance SW8000 4 Cylinder Diesel	56107505		
Advance SW8000 4 Cylinder LPG / Cab	56107509		
Advance SW8000 4 Cylinder Gasoline / Petrol Cab	56107507		
Advance SW8000 4 Cylinder Diesel / Cab	56107511		56042601 56042603

These manuals can be found in the following locations:

- EzParts within Nilfisk-Advance Dealer Customer Zone website or EzParts CD-ROM
- Nilfisk-Advance website: www.Nilfisk-Advance-us.com

Engine Manufacturers' Technical Manuals

Engine Type	Publication Title
Diesel:	Kubota 05 Series Service Data Book 9Y110-00051.pdf
	Workshop Manual, Diesel Engine, 05 Series, WG1605 9Y111-00126.pdf
	Woodward Product Specification 03399, APECS™ 0175 Series Actuators
Gas/LPG:	Operator's Manual WG1605 EG523-89162ENG.pdf
	Engine Specifications WG1605 9Y110-01770.pdf
	Workshop Manual WG1605 9Y111-06610.pdf
	Diagnosis Manual ECM System WG1605 9Y110-01760.pdf

Parts And Service

Repairs, when required, should be performed by your Authorized Advance Service Center, who employs factory trained service personnel, and maintains an inventory of Advance original replacement parts and accessories.

Call the ADVANCE DEALER named below for repair parts or service. Please specify the Model and Serial Number when discussing your machine.

(Dealer, affix service sticker here.)

Name Plate

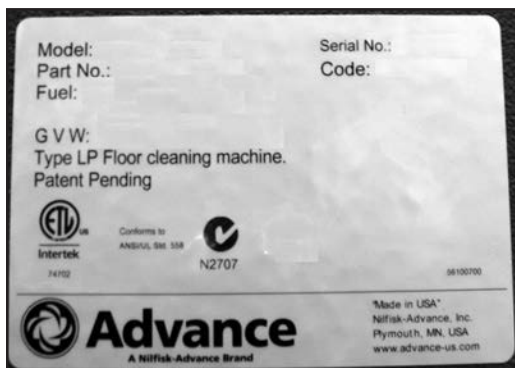

Unit Nameplate



Unit Nameplate Location

The Model Number and Serial Number of your machine are shown on the Nameplate on the machine. The Model Name imprinted on the nameplate will be SW8000 and the Part Number will correspond to engine type and options on the machine (example: “56107503”). This information is needed when ordering repair parts for the machine. Use the space below to note the Model Number and Serial Number of your machine for future reference.

MODEL NUMBER _____

SERIAL NUMBER _____

Caution and Warning Symbols

It is important for you to read and understand this manual. The information it contains relates to protecting your safety and preventing problems. The symbols below are used to help you recognize this information.



Warning: Indicates a potentially hazardous situation which, if not avoided, could result in death or serious injury.



Caution: Indicates a potentially hazardous situation which, if not avoided, could result in minor or moderate injury.

Caution: When used without the Safety Alert Symbol, indicates a potential situation which, if not avoided, could result in property or machine damage.

General Safety Instructions

Specific Cautions and Warnings are included to warn you of potential danger of machine damage or bodily harm.



Warning!

- This machine emits exhaust gases (carbon monoxide) that can cause serious injury or death, always provide adequate ventilation when using machine.
- This machine shall be used only by properly trained and authorized persons.
- This machine is not intended for use by persons (including children) with reduced physical, sensory or mental capabilities, or lack of experience and knowledge.
- While on ramps or inclines, avoid sudden stops. Avoid abrupt sharp turns. Use low speed down ramps.
- To avoid hydraulic oil injection or injury always wear appropriate clothing and eye protection when working with or near hydraulic system.
- Turn the key switch off (O) and disconnect the batteries before servicing electrical components.
- Never work under a machine without safety blocks or stands to support the machine.
- Do not dispense flammable cleaning agents, operate the machine on or near these agents, or operate in areas where flammable liquids exist.
- Only use the brushes provided with the appliance or those specified in the instruction manual. The use of other brushes may impair safety.
- Do not use the machine without a falling object protective structure (FOPS) in areas where it is likely that the operator is hit by falling objects.
- Machines shall be parked safely.
- The machine shall be inspected by a qualified person regularly, in particular regarding the LPG container and their connections, as required for safe operation by regional or national regulations.
- Observe the Gross Vehicle Weight, GVW, of the machine when loading, driving, lifting or supporting the machine.

**Caution!**

- *This machine is not approved for use on public paths or roads.*
- *This machine is only approved for hard surface use.*
- *This machine is not suitable for picking up hazardous dust.*
- *When operating this machine, ensure that third parties, particularly children, are not endangered.*
- *Before performing any service function, carefully read all instructions pertaining to that function.*
- *Do not leave the machine unattended without first turning the key switch off, removing the key and applying the parking brake.*
- *Turn the key switch off and remove the key, before changing the brooms, and before opening any access panels.*
- *Take precautions to prevent hair, jewelry, or loose clothing from becoming caught in moving parts.*
- *Before use, all doors and hoods should be properly latched.*
- *The battery must be removed from the machine before the machine is scrapped. The disposal of the battery should be safely done in accordance with your local environmental regulations.*
- *Do not use on surfaces having a gradient exceeding that marked on the machine.*
- *All doors and covers are to be positioned as indicated in the instruction manual before using the machine.*

Hopper Safety Support



Warning! Make sure the Hopper Safety Support is in place by using the Hopper Safety Support Handle whenever attempting to do any maintenance work under or near the raised hopper. The Hopper Safety Support mechanically holds the hopper in the raised position to allow work to be performed under the hopper. NEVER rely on the machine's hydraulic components to safely support the hopper. See "To Engage The Safety Support" below.

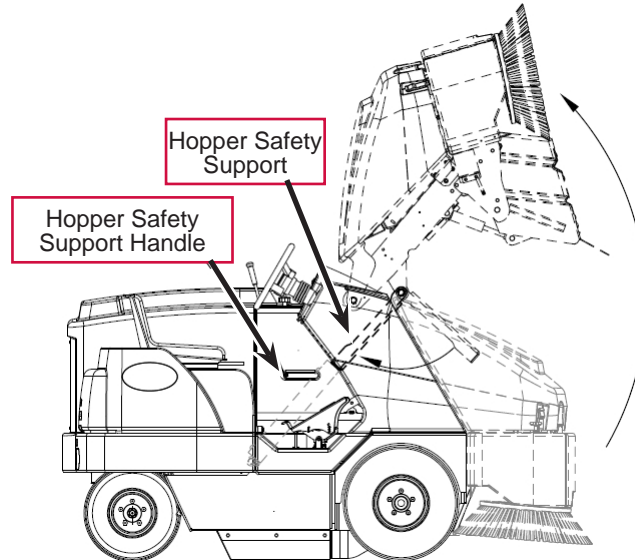

Hopper Safety Support

The Hopper Safety Support must be engaged whenever personnel are working on or underneath the hopper. The safety support prevents the hopper from being lowered, or from dropping down accidentally if there's a failure in the hydraulic system. The Hopper Safety Support Handle operates the Hopper Safety Support.

To engage the Safety Support:

1. Raise the hopper to its full-up position.
2. Pull the Hopper Safety Support Handle toward the rear of the machine to engage the Safety Support as shown here.
3. Lower the hopper to rest on the Safety Support.

To disengage the Safety Support.

1. Raise the hopper to its full-up position.
2. Push the Hopper Safety Support Handle toward the front of the machine to the disengaged position.
3. Lower the hopper.

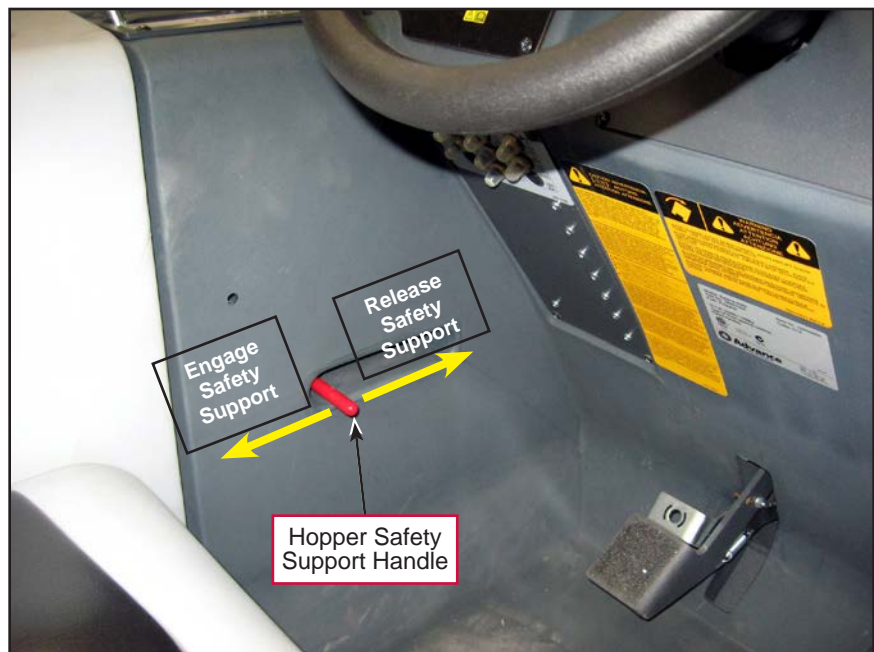

Hopper Safety Support Operation

Jacking The Machine



Caution! Never work under a machine without safety stands or blocks to support the machine.

- When jacking the machine, do so at designated locations (Do Not jack on the hopper)

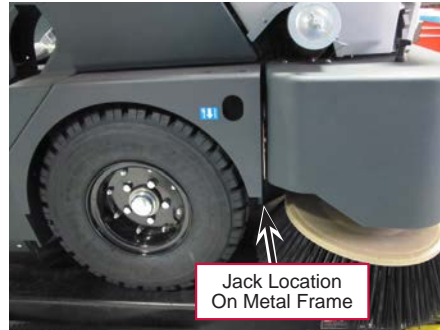
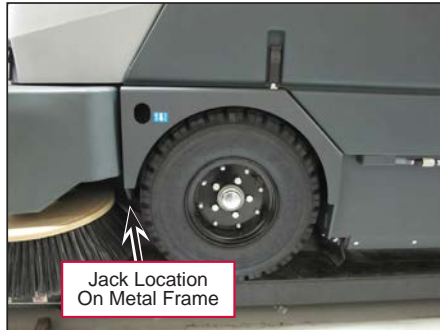

Transporting The Machine



Caution! Before transporting the machine on an open truck or trailer, make sure that . . .

- All access doors are latched securely.
- The machine parking brake is set.
- The machine is tied down securely - see tie-down locations in following figures.

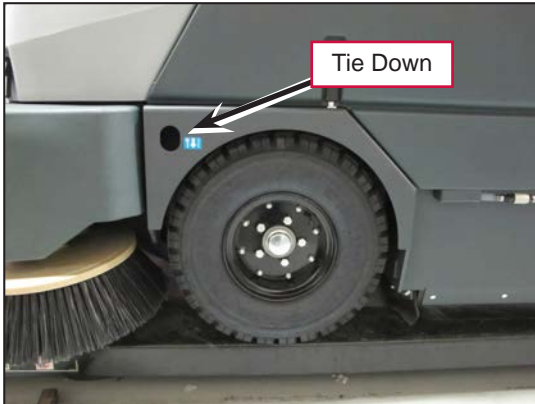

Tie Down - Left Front



Tie Down - Left Rear

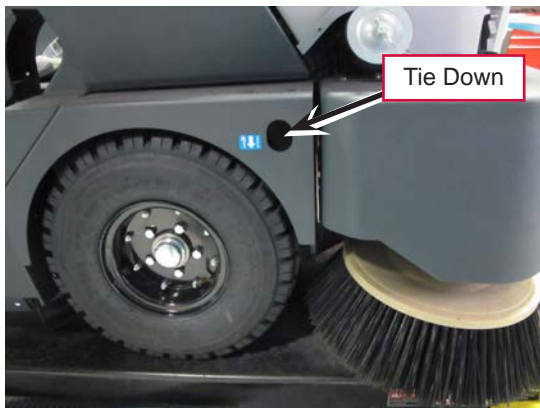

Tie Down - Right Front



Tie Down - Right Rear

Towing Or Pushing A Disabled Machine



Caution! The machine's drive propelling pump is manufactured with an adjustable tow valve. This valve prevents damage to the hydraulic system when the machine is being towed/pushed short distances without use of the engine. To access the valve; unlatch and open the Oil Reservoir / Fuel Tank Cover, then open the Engine Compartment Cover and locate the hydrostatic pump at the rear of the engine. The illustration below shows the location. Turn the valve 90 degrees; this disengages the hydrostatic lock between the motor and pump.

The hydraulic propelling pump can be damaged if the machine is towed with the valve in the normal working position. Reference the illustration below for the normal working setting (vertical) and the free wheeling towing setting (horizontal). Note: If the tow valve is left in free wheeling (horizontal) position the propelling pump can't drive the machine FWD or REV. No damage will result, just re-set valve to the normal working setting (vertical).

NOTE: Tow or push machine no faster than a normal walking pace (2-3 miles per hour) and for short distances only. If the machine is to be moved long distances the drive wheel needs to be raised off the floor and placed on a suitable transport dolly.

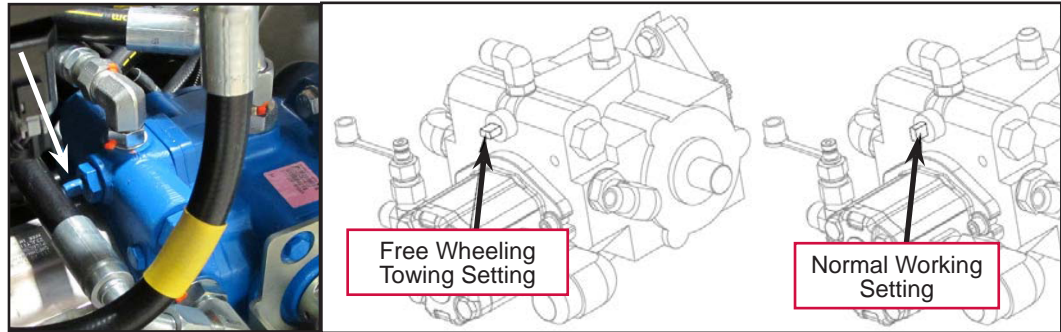

Hydraulic Propelling Pump Tow Valve

Technical Specifications

General Specifications common to All Models

English (Metric)

Dimensions

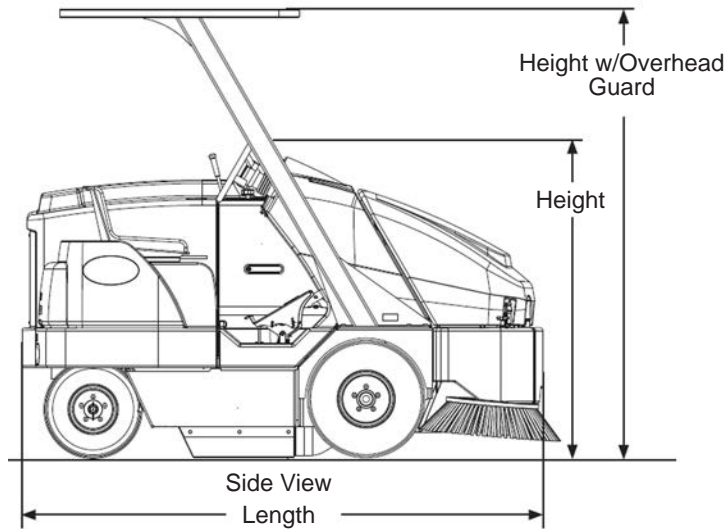

Side View

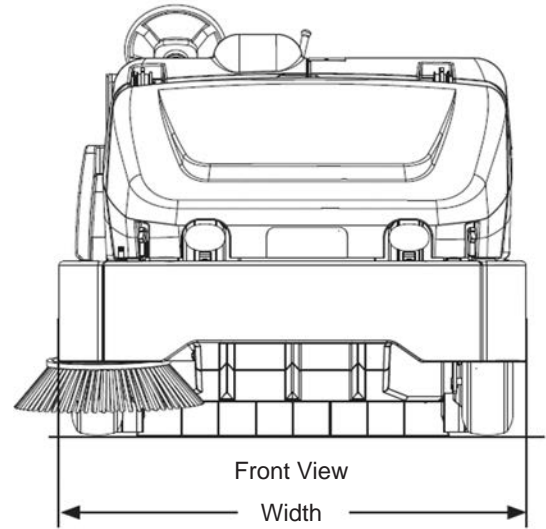

Front View

Length	95 inches (2241 cm)
Width (minimum)*	64 (163cm)
Height	59 inches (150cm)
Height w/overhead guard	81.25 inches (206cm)
Height w/cab	79 inches (201cm)
Ground clearance	3.5 inches (8.9cm)
Minimum ceiling height dumping clearance	101.4 inches (257.5cm)

Weights

Gross weight, without cab**	4426 lbs. (2007kg)
Gross weight, with cab**	4775 lbs. (2165kg)

Sweep System

Main broom length	50 inches (127cm)
Main broom diameter	14 inches (35.5cm)
Main broom bristle length	3.25 inches (8.26cm)
Sweeping path w/single side broom	65 inches (165cm)
Sweeping path w/dual side brooms	77 inches (196cm)
Side broom diameter (STD)	26 inches (66cm)
Side broom bristle length	6 inches (15.2cm)

***Width (minimum):** Width of machine body at the hopper, no side brooms.

****Gross Weight:** Standard machine without options, with 175 lbs. operator, with standard sweeping brooms and full tank of fuel.

Technical Specifications

Hopper System

Capacity	14 ft ³ (396L)
Lifting capacity	1000 lbs. (454kg)
Dump height (variable)	Max. 60 inches (152cm)
Dump height with door open	52.75 inches (134cm)

Dust Control System

Filter type: Pleated paper panel STD (optional poly filter available)	
Filter media area	94 ft ² (8.7m ²)
Filter dimension	3.19" x 18" x 30" (8.1cm x 45.7cm x 76.2cm)
Dust Guard Water Misting Tank Capacity	14 gal. (53L)

Steering System

Type: Full power steering unit and hydraulic cylinder	
Turn radius left	95" (242cm)
Turn radius right	63" (160cm)
Minimum aisle turn width (left)	109 in. (277cm)

Hydraulic System

Oil type: SAE 10W-30 (fill to bottom of screen)	
System fill capacity	11 gal. (41.6L)

Engine System

Diesel & Petrol (gasoline) fuel tank capacity	12.5 gal. (47.3L)
---	-------------------

Tires

Tire pressure (all 3)	90-100 PSI (6.2 - 6.9 bar)
-----------------------	----------------------------

Engine

Sound Level

At operators ear - LPG/Gasoline (Petrol)	79.3 dBA
At operators ear - Diesel	85.5 dBA

Speed and Gradeability

Maximum grade angle (transport)	20% / 11.3°
Maximum grade angle (sweeping)	20% / 11.3°
Maximum trailer loading angle (all models)	19.4°
Travel speed (Maximum forward)	9 mph (14.5km/h)
Maximum reverse speed	5.5 mph (8.8km/h)

***Width (minimum):** Width of machine body at the hopper, no side brooms.

****Gross Weight:** Standard machine without options, with 175 lbs. operator, with standard sweeping brooms and full tank of fuel.

Fastener Torque Specifications

Standard Torque Specifications (unless otherwise specified)	Size	Plated Steel	Stainless Steel
	#10	42 in.-lb.	28 in.-lb.
	1/4"	100 in.-lb.	67 in.-lb.
	5/16"	17 ft.-lb.	11 ft.-lb.
	3/8"	31 ft.-lb.	20 ft.-lb.
	1/2"	75 ft.-lb.	50 ft.-lb.
	3/4"	270 ft.-lb.	180 ft.-lb.
	M5	61 in.-lb.	36 in.-lb.
	M6	9 ft.-lb.	62 in.-lb.
	M8	22 ft.-lb.	13 ft.-lb.
	M10	44 ft.-lb.	25 ft.-lb.
	M12	70 ft.-lb.	40 ft.-lb.

Maintenance

Maintenance Schedule

Maintenance intervals given are for average operating conditions. Machines used in severe operational environments may require service more often.

Maintenance Item	Perform Daily				
Perform the "After Use" maintenance steps	X				
Check parking brake	X				
*Clean main and side broom(s)	X				
Check filter indicator and lights (hyd & air)	X				
Check engine coolant level	X				
Check hydraulic oil level	X				
Maintenance Item	15 hrs.	30 hrs.	150 hrs.	300 hrs.	1000 hrs.
*Rotate main broom	X				
Clean the DustGuard™ Spray Nozzles & Strainer	X				
*Inspect/adjust brooms		X			
* Check / Clean Hopper Dust Control Filter Using Method "A"		X			
*Inspect broom housing skirts		X			
*Inspect hopper seals		X			
Clean radiator and oil cooler		X			
Perform engine maintenance			X		
*Inspect and grease steering spindle			X		
* Check / Clean Hopper Dust Control Filter Using Method "B"			X		
* Check / Clean Hopper Dust Control Filter Using Method "C"				X	
Change the hydraulic oil filter					X
Change reservoir hydraulic oil					X
Flush the radiator					X
Engine fuel filter(s)					X

*See the Mechanical Repair Service Manual for detailed maintenance information of systems listed. (Sweeping, Hopper, Steering, Dust Control). NOTE: Cleaning the hopper dust control filter is not required on models using the maintenance free bag filter.

After Use

1. Shake the Hopper Dust Control Filter (Figure 6, #12) and empty the hopper.
2. Check the maintenance schedule and perform all required maintenance before storage.
3. Move the machine to an indoor storage area.
4. Shut down the engine according to the shut down procedures.
5. Make sure the Ignition Switch is OFF and the Parking Brake is engaged.



Note: It is safe to clean this machine with a pressure washer as long as you do not spray directly at or into electrical components or at the radiator or hydraulic oil cooler. The machine should always be allowed to dry completely before each use

To Shut Down The Diesel / Gasoline Engine

1. Turn all controls to the OFF position.
2. Raise the brooms.
3. Place the Engine Speed Switch in IDLE and let the engine idle for 25 - 30 seconds.
4. Turn the Ignition Key Switch OFF and remove the key.
5. Apply the Parking Brake.

To Shut Down The Propane Engine

1. Turn all controls to the OFF position.
2. Raise the brooms.
3. Turn the service valve on PROPANE Tank OFF.
4. Run the engine until all the PROPANE is dispelled from the line (the engine will stall).
5. Turn the Ignition Key Switch OFF and remove the key.



Note: The 4 cylinder LPG engine will continue to run for a few seconds after switching the key to off. This is part of the proper operation of the closed loop electronic control system.

6. Apply the Parking Brake.

Important Machine Lubrication

Rear Steering Yoke Bearing Assembly : Once every 150 hours attach a grease gun to the yoke bearing pivot zerk (location under operator's seat) and pump a small amount of grease into bearing assembly.

Also every 150 hours apply light machine oil to maintain free movement of all general pivot points. Example the seat adjustment track, and broom door hinges etc. Broom and hopper pivots use composite bearings; lubrication is not required.



Caution! For the protection of the environment; when servicing any of the machine's lubrication fluids they must be disposed of safely in accordance with your local environmental regulations (recycling). Examples of machine lubrication products: (Engine crankcase oil, Engine crankcase oil filter, Hydraulic system oil, Hydraulic system oil filters).

Engine Coolant



Caution! Do not remove the radiator cap when the engine is hot.

To check the engine coolant level, first unlatch and open the Oil Reservoir / Fuel Tank Cover then tilt the Engine Compartment Cover and observe the coolant level on the Coolant Recovery Tank. For Cab equipped models, the cab panels and left side window must be opened in order to tilt the Engine Compartment Cover.

If the level is low add a mixture of half water and automotive type anti-freeze. Clean the radiator and oil cooler exteriors by washing with **LOW-PRESSURE** water every 30 hours.



Caution! Do not use a pressure washer on the radiator or hydraulic oil cooler. Doing so may bend the cooling fins reducing cooling capability.



Service Note: The oil cooler tips out for easy cleaning.

Engine Oil – Gasoline / Petrol & Lpg

Check the engine oil level when the machine is parked on a level surface and the engine is cool. Change the engine oil after the first 35 hours of operation and every 150 hours after that. Engine oil should have properties of API classification SL or higher and suited to seasonal temperatures. Refer to the Kubota Workshop Manual, Engine Specifications and Operator's Manual for the WG1605 for further information. Replace the oil filter with every oil change.

Temperature Range	Oil Weight
Above 25 C (77 F)	SAE30 or SAE10W-30 SAE15W-40
0 C to 25 C (32 F to 77 F)	SAE20 or SAE10W-30
0 C to -20 C (32 F to -4 F)	SAE10W or SAE10W-30

Engine Oil - Diesel

Check the engine oil level when the machine is parked on a level surface and the engine is cool. Change the engine oil after the first 35 hours of operation and every 150 hours after that. Use CF, CF-4 or CG-4 oil meeting API specifications and suited temperatures (*important reference the oil/fuel type note below for further diesel oil recommendations). Refer to the Engine System section for oil capacities and additional engine specifications. Replace the oil filter with every oil change.

Temperature Range	Oil Weight
Above 77 °F (25 °C)	SAE 30 or SAE 10W-30, SAE 10W-40
32 °F to 77 °F (0 °C to 25 °C)	SAE 20 or SAE 10W-30, SAE 10W-40
Below 32 °F (0 °C)	SAE 10W or SAE 10W-30, SAE 10W-40

* Diesel Lubricating Oil Note: Refer to the Kubota Diesel Engine 05-E3B Series Work Shop Manual for the suitable American Petroleum Institute (API) classification of engine oil according to the engine type (with internal EGR, external EGR or non-EGR) and the Fuel Type Used.

Engine Air Filter

The engine Air Filter is located in the engine compartment. Check the air mechanical vacuum filter Service Indicator before each use of the machine. Do not service the air filter unless the indicator is shown (red).



Caution! When servicing the engine air filter elements, use extreme care to prevent loose dust from entering the engine. Dust can severely damage the engine.



Air Mechanical Vacuum Filter Service Indicator Location

The engine air filter contains a Primary (outer) and a Safety (inner) filter element. The Primary Element may be cleaned twice before being replaced. The Safety Element should be replaced every third time that the Primary Filter Element is replaced. Never attempt to clean the Inner Safety Element.

To clean the Primary Filter Element, unsnap the 2 clips at the end of the air filter housing and remove the end housing. Pull the primary element out. Clean the element with compressed air (maximum pressure 100 psi) or wash it with water (maximum pressure 40 psi). **DO NOT** put the element back into the canister until it is completely dry.

Empty dust from the outer plastic housing by squeezing the rubber flap. Orientate flap down when reinstalling.

Engine Maintenance (150 Hours)

At 150 hour intervals it is recommended that the following service be performed: Change oil and filter, clean and inspect spark plugs, check all engine belts condition and adjustment, check battery charge and level, check cooling system hoses and clamps and check general condition and performance of engine.



Note: See the “Other Manuals Available” section for a complete list of the engine manuals that are available.

Hydraulic Oil



Caution! To avoid hydraulic oil injection or injury, always wear appropriate clothing and eye protection when working with or near hydraulic system.

Check the Hydraulic Oil Level. Unlatch and swing open the Oil Reservoir / Fuel tank Cover. Remove the reservoir cap to check the oil level. The hydraulic oil level should be just above the bottom of the screen filter inside the filler neck of the reservoir. Add SAE 10W30 motor oil if it is below this level. Change the oil if major contamination from a mechanical failure occurs.

Change the Hydraulic “Charge” Oil Filter once a year or every 1000 hours.

Hopper Dust Control Filter (Panel Filter)

The hopper dust control filter must be cleaned regularly to maintain the efficiency of the vacuum system. Follow the recommended filter service intervals for the longest filter life.



Caution!

- Wear safety glasses when cleaning the filter.
- Do not puncture the paper filter.
- Clean the filter in a well-ventilated area.
- Wear appropriate dust mask to avoid breathing in dust.

To remove the hopper dust control filter...

1. Unlatch and open the Hopper Cover. Make sure that the Hopper Cover Prop Rod is in place.
2. Inspect the top of the Hopper Dust Control Filter for damage. A large amount of dust on top of the filter is usually caused by a hole in the filter or a damaged filter gasket.

Inspect the bottom of the Hopper Dust Control Filter. If the filter is covered with wet or dry mud, the dust control system will not function properly without replacing or thoroughly cleaning the filter using Method “C”.

3. Loosen the four Shaker Assembly Retainer Knobs. Lift off the Dust Filter Shaker Assembly to access the panel filter.



Note: Be careful not to damage the shaker motor wiring.

4. Pull the Hopper Dust Control Filter out of the machine.
5. Clean the filter using one of the methods below:

Method “A”

Vacuum loose dust from the filter. Then gently tap the filter against a flat surface (with the dirty side down) to remove loose dust and dirt.



Note: Take care not to damage the metal lip which extends past the gasket.

Method “B”

Vacuum loose dust from the filter. Then blow compressed air (maximum pressure 100 psi) into the clean side of the filter (in the opposite direction of the airflow).

Method “C”

Vacuum loose dust from the filter. Then soak the filter in warm water for 15 minutes, then rinse it under a gentle stream of water (maximum pressure 40 psi). Let the filter dry completely before putting it back into the machine.

6. Follow the instructions in reverse order to install the filter. If the gasket on the filter is torn or missing, it must be replaced. **NOTE:** Before replacing filter clear debris from dust plate located under filter. Verify that the debris flap at the rear of the dust plate swings freely.

SW8000 PM Checklist

Customer _____
 Address _____
 City _____ St _____ Zip _____
 Model _____ Serial _____ Hours _____

Defect Codes
A Needs Adjustment
B Binding
C Dirty or Contaminated
D Damaged, Bent or Torn
L Leaks
M Missing
W Worn Out

Ref	OPERATIONAL INSPECTION ITEMS	OK	Defect Codes (circle)	Does Not Work
1	Check Neutral Safety/Sense Switch operation (To test depress drive pedal and start the engine; it should not start.)		A B C	
2	Engine Starting with pedal in neutral (if it will not start, check sensor switch programming)		Starts Hard	
3	Engine Speeds 4 cyl G/P (1200 - 2400 RPM)		A Low Power	
4	Engine Speeds Diesel (note electrical actuator linkage 1200 - 2400 RPM)			
5	Drive Pedal Linkage (check for FWD/REV drive and any neutral creep)		A B	
6	Drive System Performance		Noisy Sluggish	
7	Brakes (check both service & parking)		A B W	
8	Steering		Excsssive Play	
9	Hopper Up/Down (also check operation of the safety hopper support)		A B	
10	Hopper Dump Door Open/Close		A B	
11	Main Broom Raise /Lower		<----->	
12	Side Broom Raise /Lower		<----->	
13	Main Broom On/Off		<----->	
14	Side Broom On/Off		<----->	
15	Headlights, Gauges and Optional Accessories (example rotating beacon, backup alarm)			
16	Dust Control Filter Shaker & Vacuum Impeller		<----->	
17	Tilt Steering Mechanism (OPT) and Seat Adjustment lever		A B	
18	DustGuard (OPT) Water Pump Operation On/Off			

Ref	VISUAL INSPECTION ITEMS	Comments	OK	Defect Codes (circle)	Does Not Work
19	Side Broom Pattern & Height Adj. (min bristle length 3 inches)	3 O'clock to 11		A B D W	
20	Side Broom Motor			B L	
21	Hopper Cover Gasket			D W	
22	Hopper Dust Filter & Gasket			D W	
23	Dust Control Vacuum Impeller Motor			L	
24	Hopper Dump Door Cylinder				
25	Hopper Skirting & Seals (raise hopper to inspect)				
26	Hopper Dump Door & Seal (raise hopper to inspect)			A B D W	
27	Hopper Lift Cylinder & Hopper Interlock Switch			D M W	
28	Main Broom Pattern Adjustment (min bristle wear 2-1/2" 6.4cm length)			A B D W	

29	Main Broom Motor (open left side access door to inspect)			B L	
30	Broom Housing & Door Skirts			D M W	
31	Front tires (check lug nut torque 80FT LB, 108 Nm)			L W	
32	Battery			C W	
33	Engine Air Cleaner Element (inner & outer)			C W	
34	Circuit Breaker/Relay panel (inspect electrical connections)			C D	
35	Hydrostatic Dump Valve			B	
36	Hopper Up Transport Speed control Cam/Cable Linkage			A B	
37	Propulsion drive & Accessory Pumps			L	
38	Hydraulic Reservoir, System Hoses & fittings			L	
39	Propulsion Pump Hydro Back Cable & Clevis Connections			B M W	
40	Engine, Oil Level, Hoses & Belts			Add or Change L W	
41	Engine Coolant Level			L Add Coolant	
42	Radiator & Oil Cooler Core Blockage			L Needs Cleaning	
43	Hydraulic Oil Reservoir Level (10W-30 engine oil only)			L Add Oil	
44	Hydraulic Oil Filter			L Replace	
45	Steer Spindle & Drive Wheel motor (open operator's seat)			D L	
46	Rear Tire (check lug nut torque 100 FT LB, 135Nm)			L M W	
47	Gasoline/Diesel tank , Filter & Lines			C L	
48	LP Tank, Hoses & Fittings			L	
49	LP Fuel Filter			L Replace	
50	LP Fuel Regulator, Lock Off Valve & Hoses			L	
51	Diesel Glow Plug Indicator Light			Replace	
52	Diesel Fuel Filter			L Replace	
53	Engine Air-Intake Hose Assembly (air inlet to engine)			C L	
54	DustGuard Water Tank, Misting Pump & Storage Tank				

NOTE: For additional service information see service manual form number 56043163 and operators manual form number 56091065 (English & Spanish).

Defect Codes	A Needs Adjustment	C Dirty or Contaminated	M Missing
	B Binding	D Damages, bent or torn	W Worn Out
		L Leaks	

Work Completed By:

Acknowledged By:

Service Technical Signature

Date

Customer Signature

Date

Know Your Machine

Refer to these pages whenever necessary to pinpoint the location of an item mentioned in this manual.

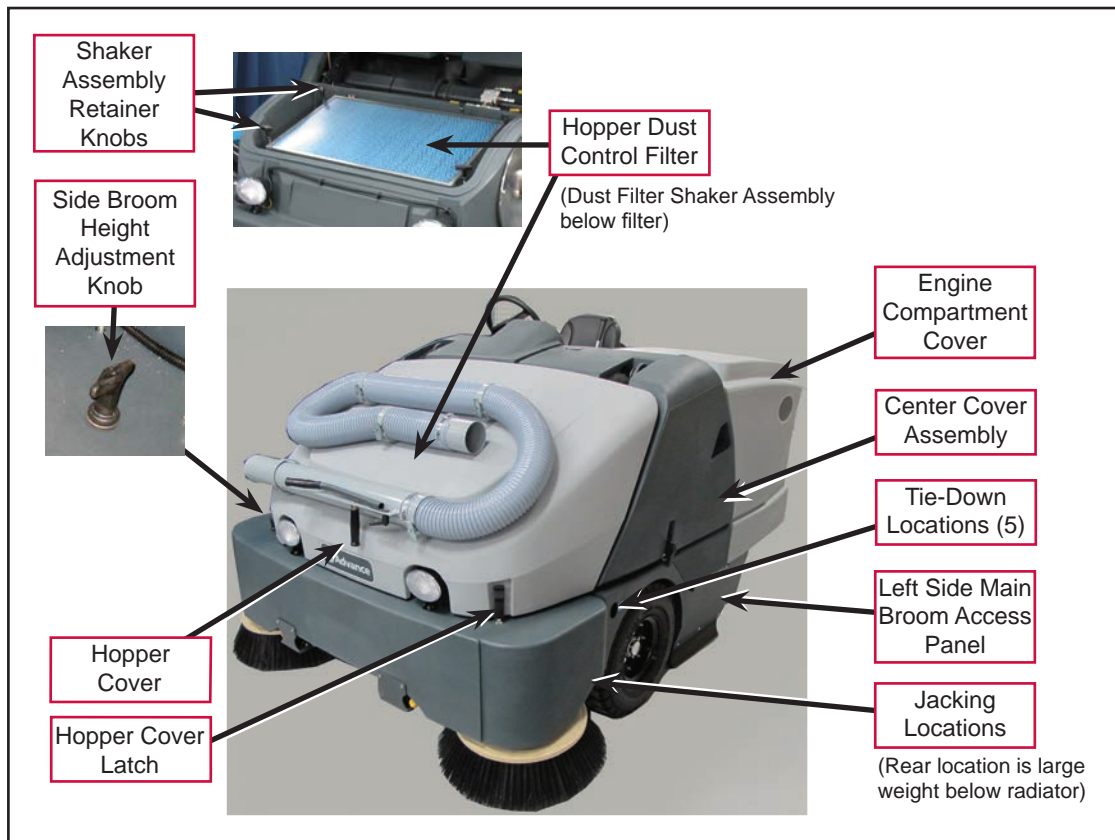

Know Your Machine

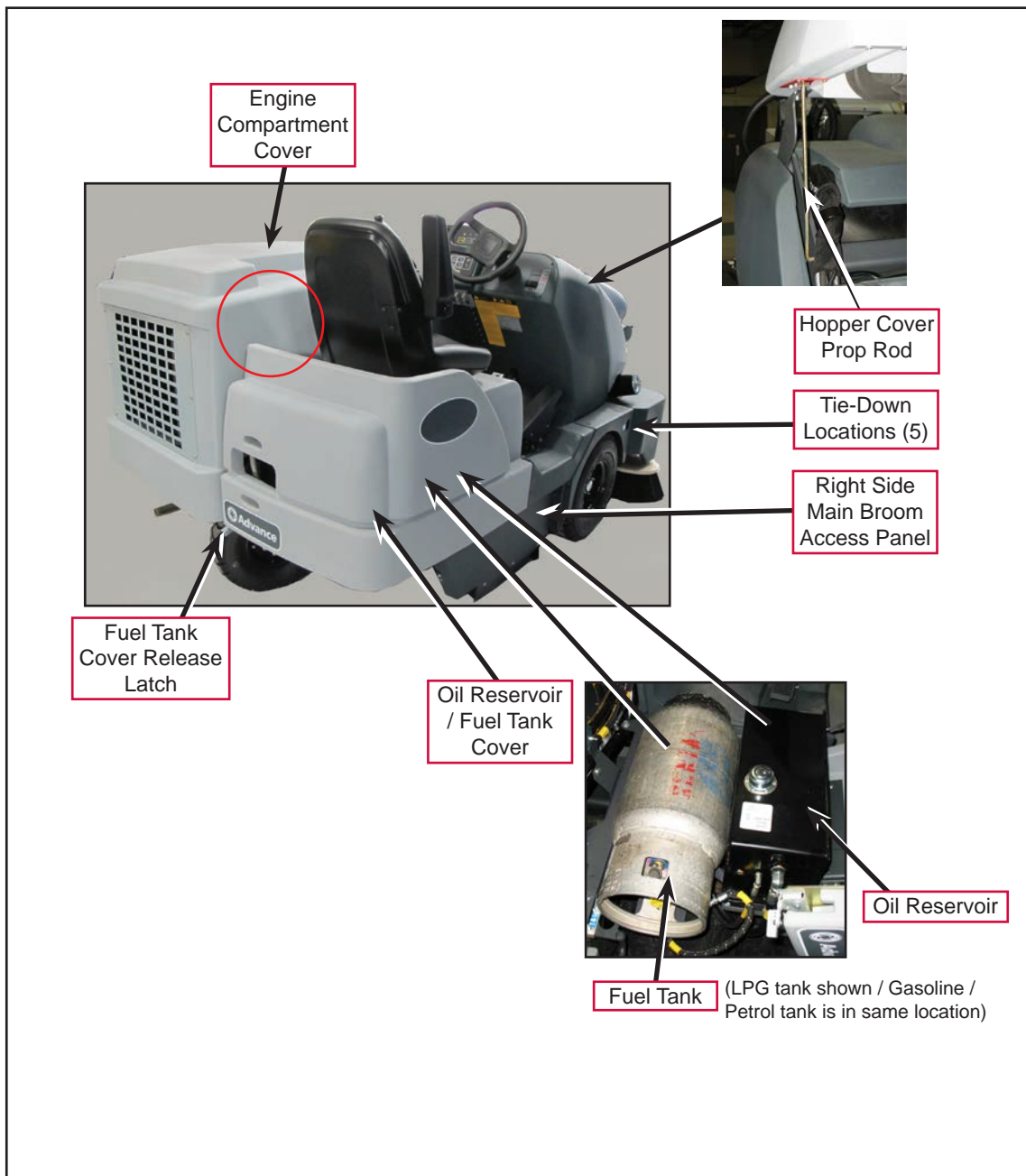

Know Your Machine

Operator's Compartment

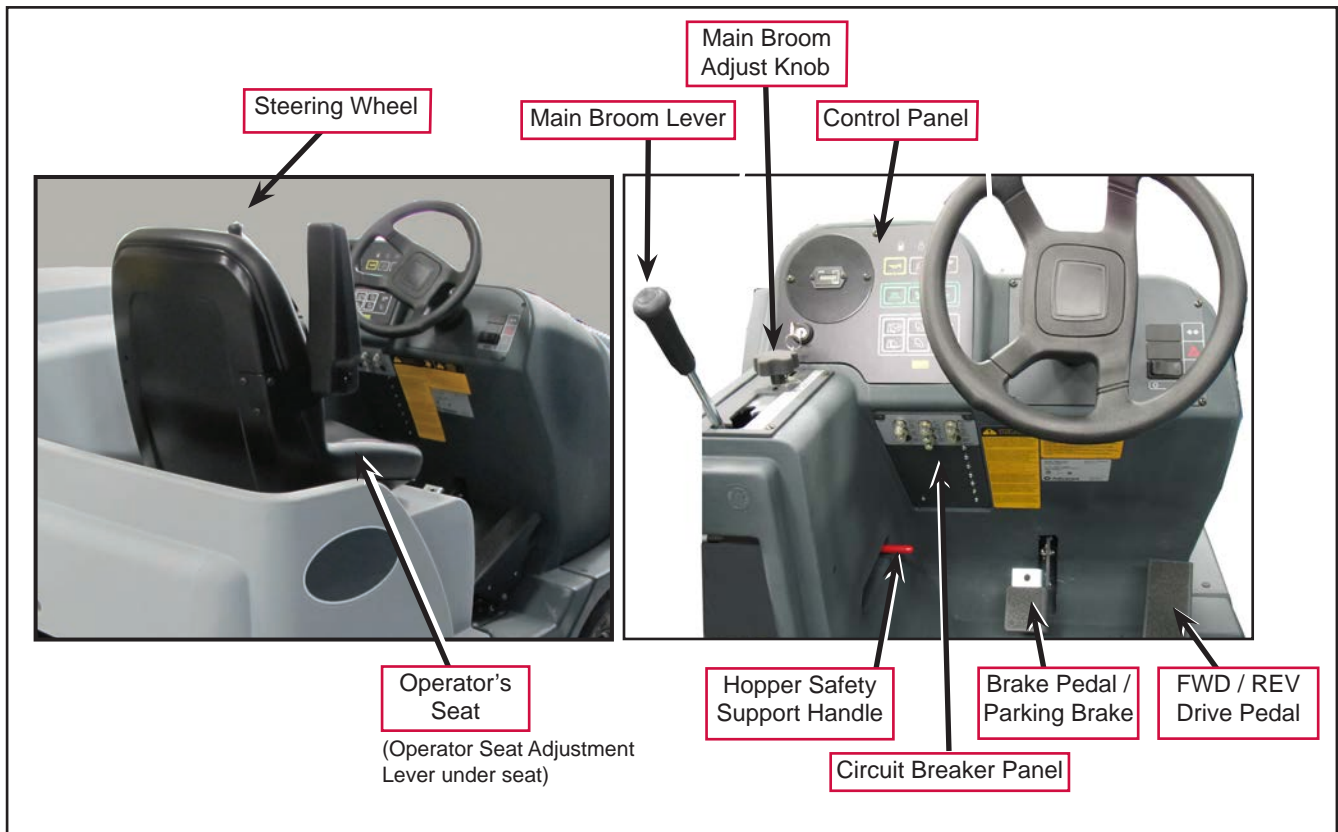

Know Your Machine

Control Panel

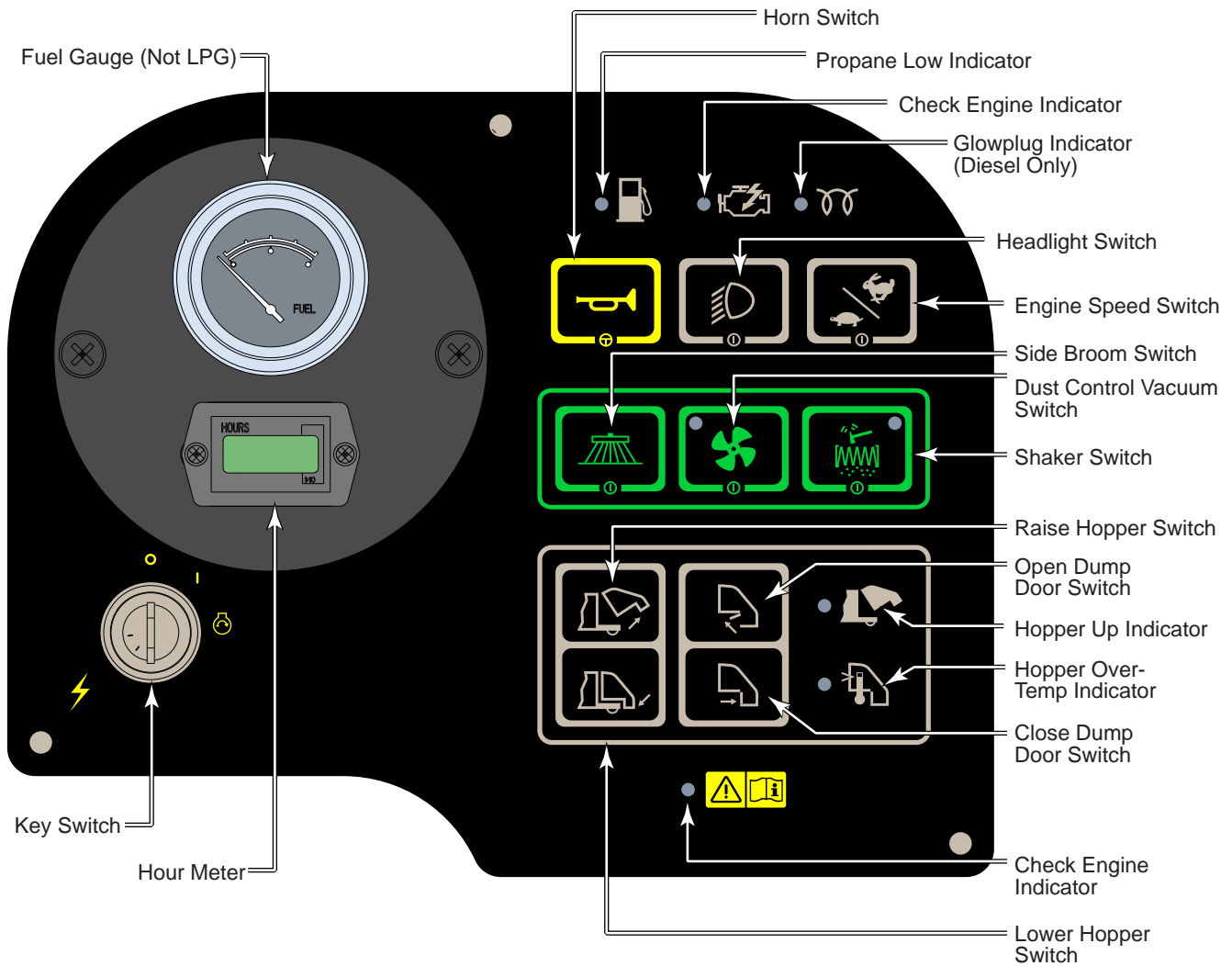

Optional DustGuard and Signalling Switches

Know Your Machine

Control System

Functional Description

The SW8000 utilizes a main machine controller to turn on various machine functions. It receives sensor inputs and operator inputs, and activates various solenoids and components. The main machine controller is separate from the engine controller. The only engine function controlled by the main machine controller is the engine speed.

Control Panel

The control panel (display) is an integral component with the Main Machine Controller (A2) circuit board.

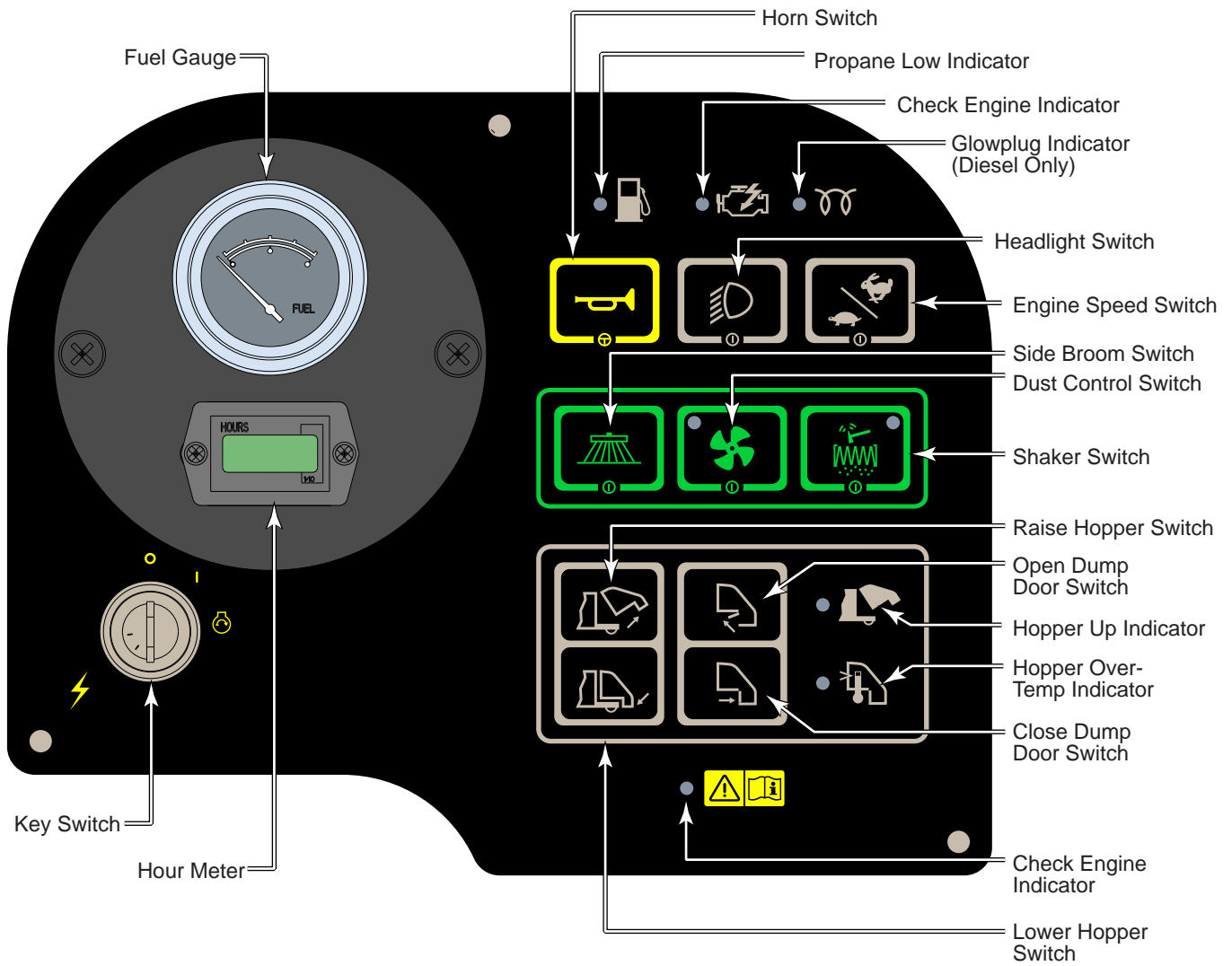

Ignition (key) Switch (A): The ignition switch serves as a main control switch for the machine and for starting the engine. The key is removable to prevent unwanted operation when not in use. For diesel engines, it also controls the function of the glow plugs.

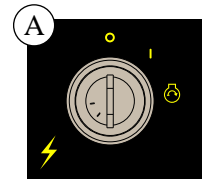

Hour Meter (B): The hour meter shows the run-time on the engine, and it use for tracking maintenance tasks.

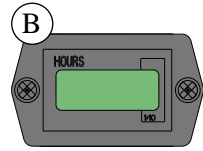

Fuel Gauge (C): For gasoline or diesel engines only. Shows the level of the fuel in the fuel tank.

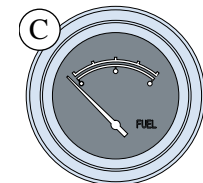

Horn Switch (D): Activates the horn

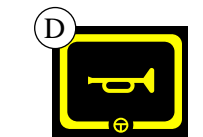

Propane Low Indicator (E): The lamp illuminates when the propane tank is empty.

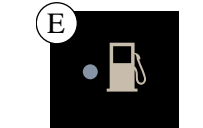

Headlight Switch (F): Turns the headlamps on and off.

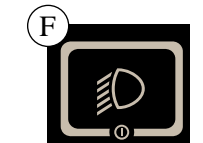

Check Engine Light (G): The lamp illuminates when the engine controller signals a problem exists with the engine.

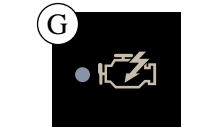

Glow Plug Indicator (H): (diesel engine only) The lamp is illuminated while the glow plugs are active. Diesel engine glow plugs preheat the cold cylinders before starting then engine. The glow plugs are activated when the ignition switch is turned to the counterclockwise position

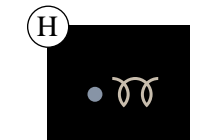

Engine Speed Switch (I): Switches between idle and run speed (rpm) of the engine. (Do not drive or otherwise operate the machine while the engine is at idle.)

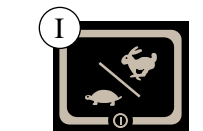

Side Broom Down/Up Switch (J): Raises and lowers the side brooms.

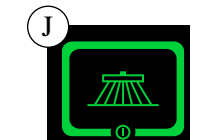

Dust Control Switch (K): Turns the dust control fan on and off.

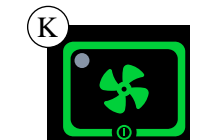

Dust Control Indicator: Illuminates when the dust control fan is active.

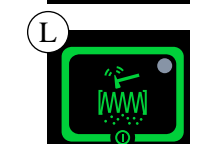

Shaker Switch (L): Turns the shaker on and off. The dust control fan automatically turns off while the shaker is active. The shaker is used to clean debris from the filter.

Plugged Filter Indicator: Optional equipment. The LED on the shaker switch illuminates when the pressure sensor indicates the filter is clogged.

Hopper Up Indicator (M): Illuminates when the hopper mechanism is not in the lowered position.

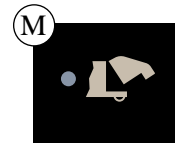

Hopper Over-temp Indicator (N): This lamp illuminates if the hopper temperature exceeds 140°F (60°C), due to ingestion of combustible materials or embers.

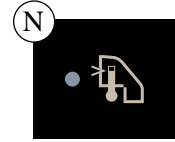

Open Dump Door Switch (O): Opens the dump door for emptying the hopper.

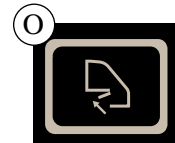

Close Dump Door Switch (P): Closes the dump door after emptying the hopper.

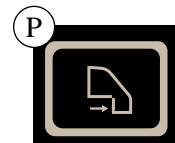

Lower Hopper Switch (Q): Lowers the hopper from the raised position after emptying the hopper.



Raise Hopper Switch (R): Raises the hopper for emptying.



Main Controller Fault Code Light (S): Flashes out the fault code for the controller. Refer to [Main Controller Error Codes](#) described on page 37 for a listing of the specific error codes.

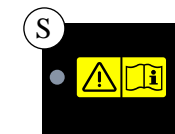

Main Machine Controller

The Main Machine Controller (**A2**) is the primary electronic control for the machine and its functions (except engine control). The control board is the basic input/output device and contains a micro-controller chip to regulate function. The controller receives and interprets user inputs and sensor inputs, and controls device output for the user display, solenoid operation, and motor control. Most low and medium power outputs are controlled with power MOSFET transistors, and very high power devices are controlled with external relays.

Another function of the Main Machine controller is to detect any system failures and flash out an error code with the fault code light (**U**) on the display panel. The error code(s) are used to help the service person determine the fault and to quickly guide in repairing a specific system malfunction. An additional special feature of the main control board is to change program settings for a set of specific machine functions. See the section, [Main Machine Controller Programming](#) described on page 36 for further information.



Component Locations

The diagram below shows component locations for some components related to the Main Machine Controller.

- Main Machine Controller
- Hydrostatic Drive Position Sensor
- DustGuard and Signaling Switches
- Engine Controller



Main Machine Controller Programming

Hydrostatic Neutral Position and Dead-band

The purpose of this adjustment procedure is to synchronize the electrical neutral position with the mechanical neutral position of the hydrostatic drive. The mechanical neutral position needs to be adjusted first, and this is where the self-centering drive cable matches the neutral position of the hydrostatic drive. A rotary sensor (potentiometer) reports the position of the drive pump lever to the main machine controller. This procedure records the voltage value of the potentiometer that signifies when the drive is in the neutral position.

The dead-band adjustment is the sensitivity of the neutral position. If the dead-band is set too narrow (too sensitive), the controller may believe the drive is in motion, when it is still in neutral, which would prevent engine starting. If set too wide, the drive may be engaged when the controller believes it is in neutral, which would prevent the sweeping system to engage.

Correctly setting these adjustments is important, because they control when the machine can be started, and also when sweeping functions activate and deactivate.

These adjustments should be made anytime the Main Machine controller or potentiometer are replaced, the mechanical adjustment is performed, or any time the machine shows symptoms of misadjustment.

1. Make sure the keyswitch is in the off position.
2. To ensure the drive is in the mechanical neutral position, press the drive pedal into reverse and slowly release it. Avoid biasing the neutral position, and do not move the pedal for the remainder of the procedure.
3. While holding the Engine Speed switch **(I)**, turn the keyswitch **(A)** to the on position. Continue to hold the speed switch until all display indicators turn off (approximately 2 seconds).
4. When the Engine Speed switch is released, the controller will record the resistance value from the drive position sensor.
5. The Fault Code Light **(S)** will indicate the dead-band setting as described below. To change the dead-band (sensitivity), press the Engine Speed switch **(I)** to cycle through the 3 options.
 - Narrow = Steady on
 - Medium = Slow flash (Default)
 - Wide = Rapid flash
6. To save the settings and exit the process, turn off the keyswitch.

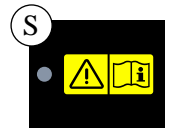
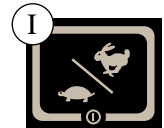

Recall of Stored Fault Codes

Past fault codes are stored in memory and may be retrieved and cleared as part of maintenance history.

1. Make sure the keyswitch is in the off position.
2. While holding the Horn switch **(D)**, turn the keyswitch **(A)** to the on position. Continue to hold the Horn switch until all display indicators turn off (approximately 2 seconds).
3. When the Horn switch is released, the Fault Code Light **(S)** will flash out the error codes. If no past error codes exist the light will remain steady-on.
4. To clear the fault code history, press and release the Horn switch. The Fault Code Light will change to steady-on.
5. To exit, turn the keyswitch off.

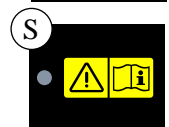
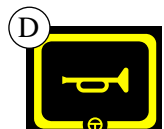

Automatic Shaker Operation

This adjustment enables or disables the automatic shaker option, and how the shaker functions when it is active in either automatic or manual operation. In either of the 2 automatic modes, the shaker will activate for 15 seconds whenever the broom is raised. Automatic operation in Liberator mode is the default setting. The 3 options are described below:

- a. **Liberator Mode:** Automatic operation with manual operation by pressing the shaker switch. When active, the shaker will be on for ½ second and off for ½ second for the 15-second duration of the cycle.
- b. **Continuous Mode:** Automatic operation with manual operation by pressing the shaker switch. When active, the shaker will run continuously for the 15-second duration of the cycle.
- c. **Manual Mode:** Manual mode only. When the shaker switch is pressed, the shaker will operate continuously for the 15-second duration of the cycle.

1. Make sure the keyswitch is in the off position.
2. While holding the Shaker switch (L), turn the keyswitch (A) to the on position. Continue to hold the Shaker switch until all display indicators turn off (approximately 2 seconds).
3. The Shaker light (L) and Fan Light (K) will indicate the current state of the automatic shaker function, as described below.
4. Press the Shaker switch to toggle through the setting.
 - Liberator Mode: Both Shaker and Fan lights on.
 - Continuous Mode: Shaker light on.
 - Manual Mode: Neither light on.
5. To exit, turn the keyswitch off.

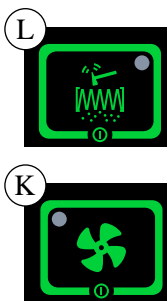

Troubleshooting

Main Controller Error Codes

The following table lists the main controller error codes. When an error code is present, the Error Code lamp (S) will flash out the specific 2-digit code(s). Count the flashes for each digit. There will be a short pause between digits, and a long pause between error codes (or before repeating the sequence of code(s)).

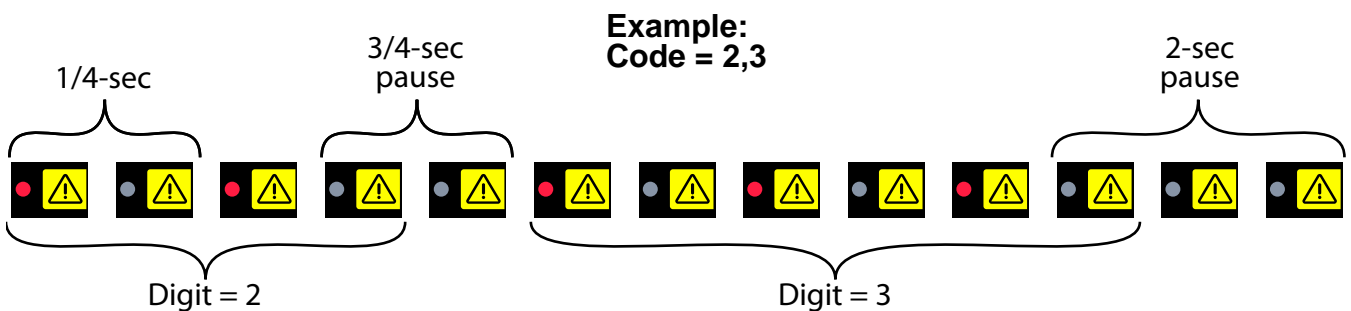
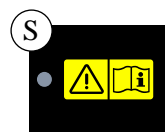

Code	Pin #	Description	Comments
1,1	J1-1	Hopper close/open solenoid (L1) overload	<ul style="list-style-type: none"> • Check coil resistance.† If below 6 Ohms replace (8 ohms nominal). • Check wiring for a short circuit (Blu/Wht)‡
1,2	J1-2	Main broom solenoid (L2) overload	<ul style="list-style-type: none"> • Check coil resistance.† If below 6 Ohms replace (8 ohms nominal). • Check wiring for a short circuit (Grn/Gra)‡

Code	Pin #	Description	Comments
1,3	J1-3	Side broom solenoid (L3) overload	<ul style="list-style-type: none"> • Check coil resistance.† If below 6 Ohms replace (8 ohms nominal). • Check wiring for a short circuit (Brn/Blk)‡
1,4	J1-4	Dust control solenoid (L4) overload	<ul style="list-style-type: none"> • Check coil resistance.† If below 6 Ohms replace (8 ohms nominal). • Check wiring for a short circuit (Brn/Yel)‡
2,1	J1-5	Hopper up/down solenoid (L5) overload	<ul style="list-style-type: none"> • Check coil resistance.† If below 6 Ohms replace (8 ohms nominal). • Check wiring for a short circuit (Red/Gra)‡
2,2	J1-6	Hopper up/bypass solenoid (L6) overload	<ul style="list-style-type: none"> • Check coil resistance.† If below 6 Ohms replace (8 ohms nominal). • Check wiring for a short circuit (Blu/Gra)‡
2,3	J1-7	Hopper door/open solenoid (L7) overload	<ul style="list-style-type: none"> • Check coil resistance.† If below 6 Ohms replace (8 ohms nominal). • Check wiring for a short circuit (Blk/Wht)‡
2,4	J1-8	Dust control bypass solenoid (L8) overload	<ul style="list-style-type: none"> • Check coil resistance.† If below 4 Ohms replace (6 ohms nominal). • Check wiring for a short circuit (Brn)‡
3,1	J1-9	Hopper lower solenoid (L9) overload	<ul style="list-style-type: none"> • Check coil resistance.† If below 6 Ohms replace (8 ohms nominal). • Check wiring for a short circuit (Yel/Grn)‡
3,2	J1-14	Shaker relay (K3) overload	<ul style="list-style-type: none"> • Check coil resistance.† If below 70 Ohms replace (85 ohms nominal). • Check wiring for a short circuit (Yel/Red)‡
3,3	J1-15	Back-up alarm overload	<ul style="list-style-type: none"> • Check wiring for a short circuit (Grn/Brn)‡ • If overload persists, replace the alarm.
3,4	J1-16	Light relay (K2) overload	<ul style="list-style-type: none"> • Check coil resistance.† If below 70 Ohms replace (85 ohms nominal). • Check wiring for a short circuit (Yel/Wht)‡
4,1	J1-18	Neutral start relay (K4) overload	<ul style="list-style-type: none"> • Check coil resistance.† If below 70 Ohms replace (85 ohms nominal). • Check wiring for a short circuit (Gry/Wht)‡
4,2	J1-19	Horn relay K1 overload Coil spec is 85 Ohms	<ul style="list-style-type: none"> • Check coil resistance.† If below 70 Ohms replace (85 ohms nominal). • Check wiring for a short circuit (Vio/Brn)‡
4,3	J1-17	Engine speed output overload Note the Gra/Blu wire is 0 V's when engine is @ idle.	<ul style="list-style-type: none"> • Throttle input to engine ECM (A3) is 0V for idle and +12V for high speed. • Check Gra/Blu wire for a short to ground.
4,4	J1-12	Spare overload Not used at this time	NA

† When testing for short circuits, make sure the machine is off, and disconnect the connectors at the solenoid or relay in question and also at the main controller. Then use an ohmmeter between the two wires at the device, or between J1-11 and the listed J# from the table. The ohmmeter should show “open circuit”.

‡ When testing a coil resistance, disconnect the connector at the device and use an ohmmeter to measure the resistance of the coil. If the value is below the minimum value from the table, replace the device.

Removal and Installation

Main Control Board

The main control board and the operator interface may be replaced separately or as an assembly. The same procedure describes either option.



Caution! *Unswitched battery power is present on the operator interface assembly. Make sure to disconnect the battery connector to avoid damaging the system or wiring.*

1. Turn off the key switch and disconnect the battery cable connector.
2. Remove the 3 screws (2) that secure the operator interface to the dash.
3. Lift the operator interface away from the dash, taking care not to stress the wiring harness.
4. Disconnect J1, J2, J3, and J4 from the control board (A2).
5. Remove the two screws (3) that secure the control board and remove the ground wire (4).
6. Remove the control board.
7. After replacing the control board with a new one, set the [Hydrostatic Neutral Position and Dead-band](#) described on page 36.
8. If necessary, also set the [Automatic Shaker Operation](#) described on page 37.

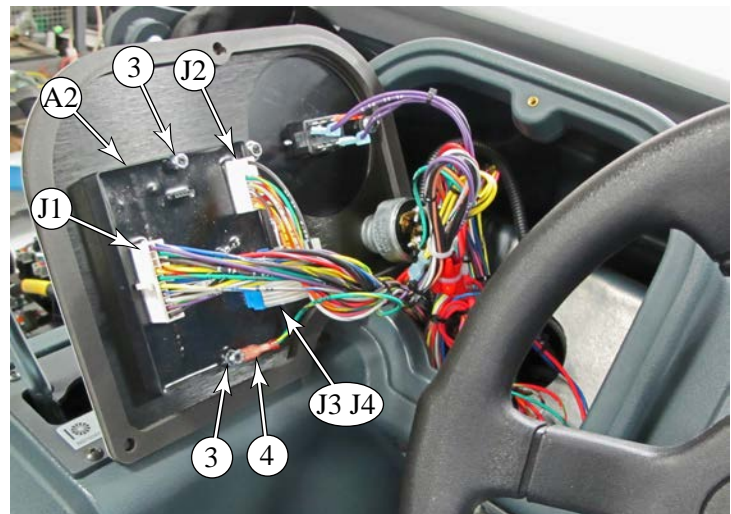

Specifications

Sample Shop Voltage Measurements

Examining signals sent and received at the control board can be very effective in determining if external components are functioning as expected or if the control board is processing them as expected. The tables below show sample voltage measurements taken from a typical machine. Actual voltages will vary from machine to machine, and with battery charge level.

To aid in taking voltage measurements from the cable connectors without removing the connector, a T-shaped push pin connected to the voltmeter probe wire works well (see image to the right).

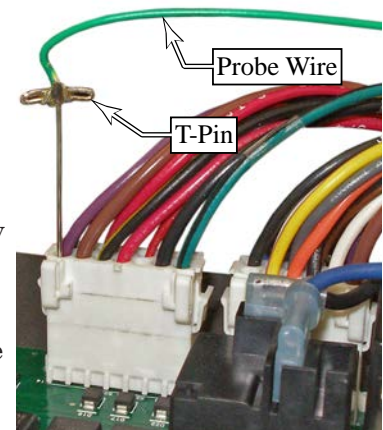

Main Machine Controller Sample Voltage Measurements at the J1 Connector					
Pin #	Name	V-On	V-Off	Ref.	Comments
J1-1	Hopper close valve	0.25	13.7	B-	
J1-2	Main broom valve	0.3	13.7	B-	
J1-3	Side broom valve	0.3	13.7	B-	
J1-4	Dust control valve	0.266		B-	Using litter control vac
J1-5	Hopper up/down valve	0.27	13.7	B-	On = raising, Off = rest or down
J1-6	Hopper up/bypass vlv	0.3	13.7	B-	
J1-7	Hopper open valve	0.25	13.7	B-	On = closed, Off = open
J1-8	Dust ctrl bypass vlv	0.3	13.7	B-	On = bypass
J1-9	Hopper lower valve	0.25	13.7	B-	On = down, Off = up or rest
J1-10	Bat-	0.011		B-	Key On
J1-11	Switched Bat+	13.9		B-	Engine run
J1-12	NC			B-	
J1-13	NC			B-	
J1-14	Shaker relay	0.07	13.9	B-	
J1-15	Back up alarm		0.01	B-	Not equipped
J1-16	Light relay	0.04	13.9	B-	
J1-17	Throttle out	13.0	2.6	B-	On = high, Off = idle
J1-18	Neutral pos. relay	0.05	13.9	B-	On = not neutral, Off = neutral
J1-19	Horn relay	0.04	12.0	B-	
J1-20	Bat-	0.01		B-	Key on

Main Machine Controller Sample Voltage Measurements at the J2 Connector					
Pin #	Name	V-On	V-Off	Ref.	Comments
J2-1	Pedal high	4.12	NA	B-	High voltage reference output of potentiometer
J2-2	Pedal wiper	1.72 full fwd 1.31 neutral 1.214 full rev		B-	
J2-3	Pedal low	0.01	NA	B-	Low voltage reference output of potentiometer
J2-4	LP low switch		5.02	B-	Not empty
J2-5	Check eng. input		4.81	B-	Engine running but no check engine signal
J2-6	Glow plug input			B-	Not available
J2-7	NC			B-	
J2-8	Dust filter switch		5.02	B-	Not available
J2-9	Hopper interlock	0.002	5.02	B-	On = down
J2-10	Hopper temperature		5.02	B-	Not available
J2-11	Ignition input	13.89		B-	
J2-12	Main broom down	0.003	5.02	B-	On = raised
J2-13	NC			B-	
J2-14	Bat-	0.013		B-	

Dust Control System

Functional Description

The purpose of the dust control system is to reduce the amount of airborne dust emanating from the machine during sweeping operations. There are two primary stages in controlling dust from the machine. The optional DustGuard™ system sprays a fine mist of water in front of each side broom to minimize the dust created by the side brooms. The vacuum-based dust control system reduces airborne dust inside the hopper by pulling air through the hopper and through a filter to trap the dust inside the hopper.

DustGuard™ Spray System (optional)

The misting pump pumps water from a separate reservoir to nozzles on the front of the machine. The nozzles direct a fine stream of water onto the floor in front of the side brooms to help reduce the dust generated by the brooms.

The DustGuard solenoid valve opens to allow water flow from the misting pump to the nozzles when the power to the misting pump switches on. A removable Strainer is installed in the water line upstream of the misting pump and solenoid valve. Removable strainers are also located inside of the nozzle assemblies.

When installed and the manual switch is activated, the DustGuard spray system will turn on automatically when the side broom is turned on.

Dust Control Vacuum System

The hydraulically driven impeller is mounted in the side wall of the hopper, and pulls air from the hopper through the filter and discharges it out the rear of the machine.

An optional clogged filter sensor/switch will shut off the vacuum motor if the vacuum on the clean side of the filter gets too high as a result of a clogged filter. When the switch is activated, the LCD will display an icon to the operator.

The filter system contains a shaker motor that vibrates the filter to shake loose particulate from the bottom of the filter to assist in keeping the filter clean. When the shaker switch is pressed, the vacuum motor turns off and the shaker motor turns on. The shaker motor contains an eccentric weight that causes vibration when rotated. This reduces filter maintenance and helps maintain adequate airflow through the filter. The filter shaker will automatically switch on for a short period when the sweep system is turned off (broom raised).

Circuit Description

Most control circuits are fairly straight forward with the controller completing the electrical circuits to ground. However, there are some electrical and hydraulic circuits with interdependencies on other circuits.

The electric misting pump is controlled by a relay from the Main Machine Controller. When the mechanical switch (S26) is closed by the operator, the misting pump relay coil is enabled, but waiting for the controller to activate the side broom circuit. When the controller sets the side broom output (J1-3) to low voltage (battery ground) it completes the circuit for both the misting pump relay and the side broom hydraulic valve.

The dust control vacuum motor has two hydraulic interdependencies for it to function. If the hopper is raised, the entire dust control hydraulic circuit is bypassed through the S6 valve, and none of the dust control or broom circuits will receive hydraulic power. When the hopper is down, the dust control vacuum motor is in series with the main broom motor. It will not receive hydraulic power unless the main broom motor is also active via the S2 Main Broom Enable valve. In its relaxed state, the S8 hydraulic valve will send fluid through the dust control vacuum motor, but when energized, the valve will bypass the motor to allow the main broom motor to operate without the vacuum motor operating.

Simplified Schematic Diagram

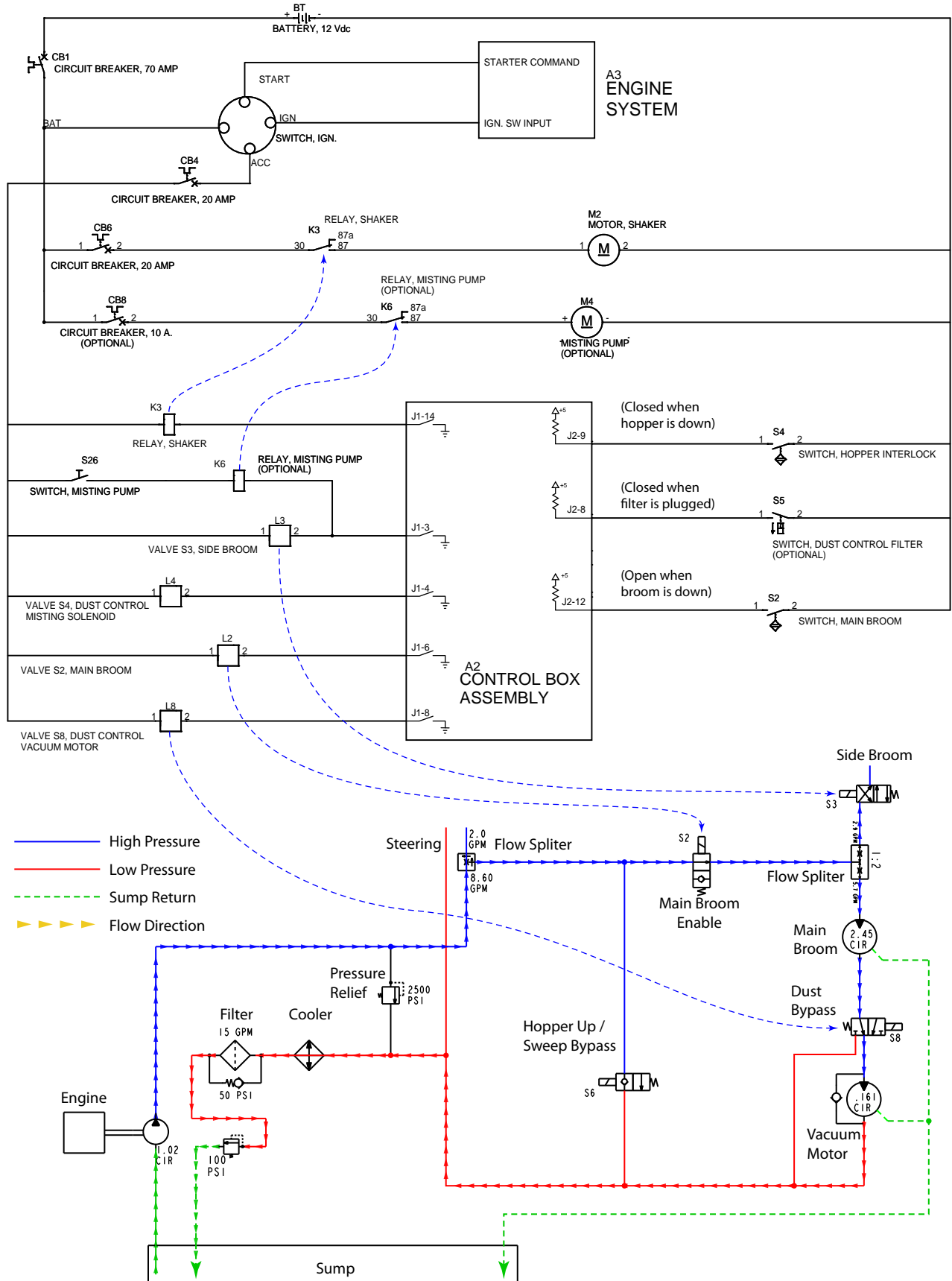

Component Locations

The diagram below shows component locations for some components related to the dust control system.

- Dust Filter
- Shaker Motor
- Vacuum Motor
- DustGuard Nozzles
- Hopper Temp Switch
- Plugged Filter Switch
- Dust Hopper
- Hopper Temp Switch
- Misting Pump

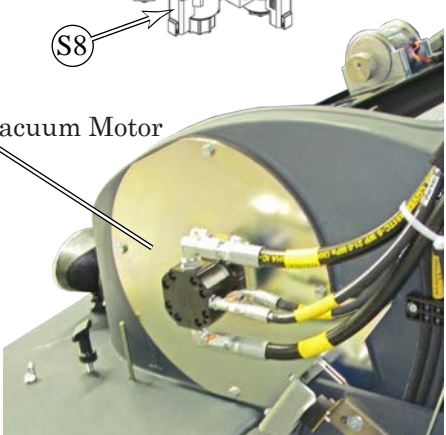
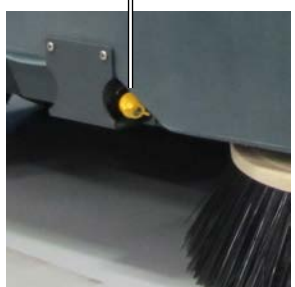
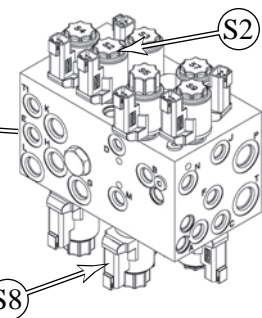
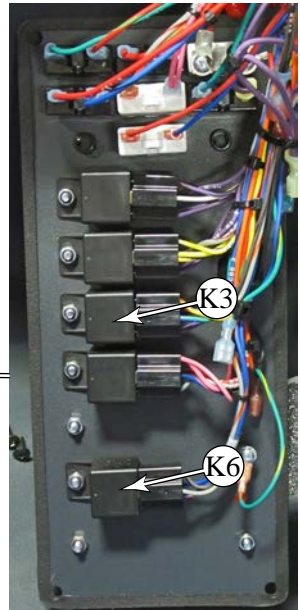
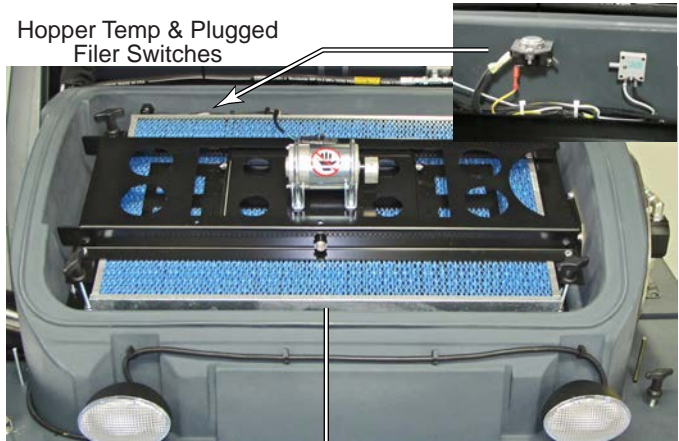
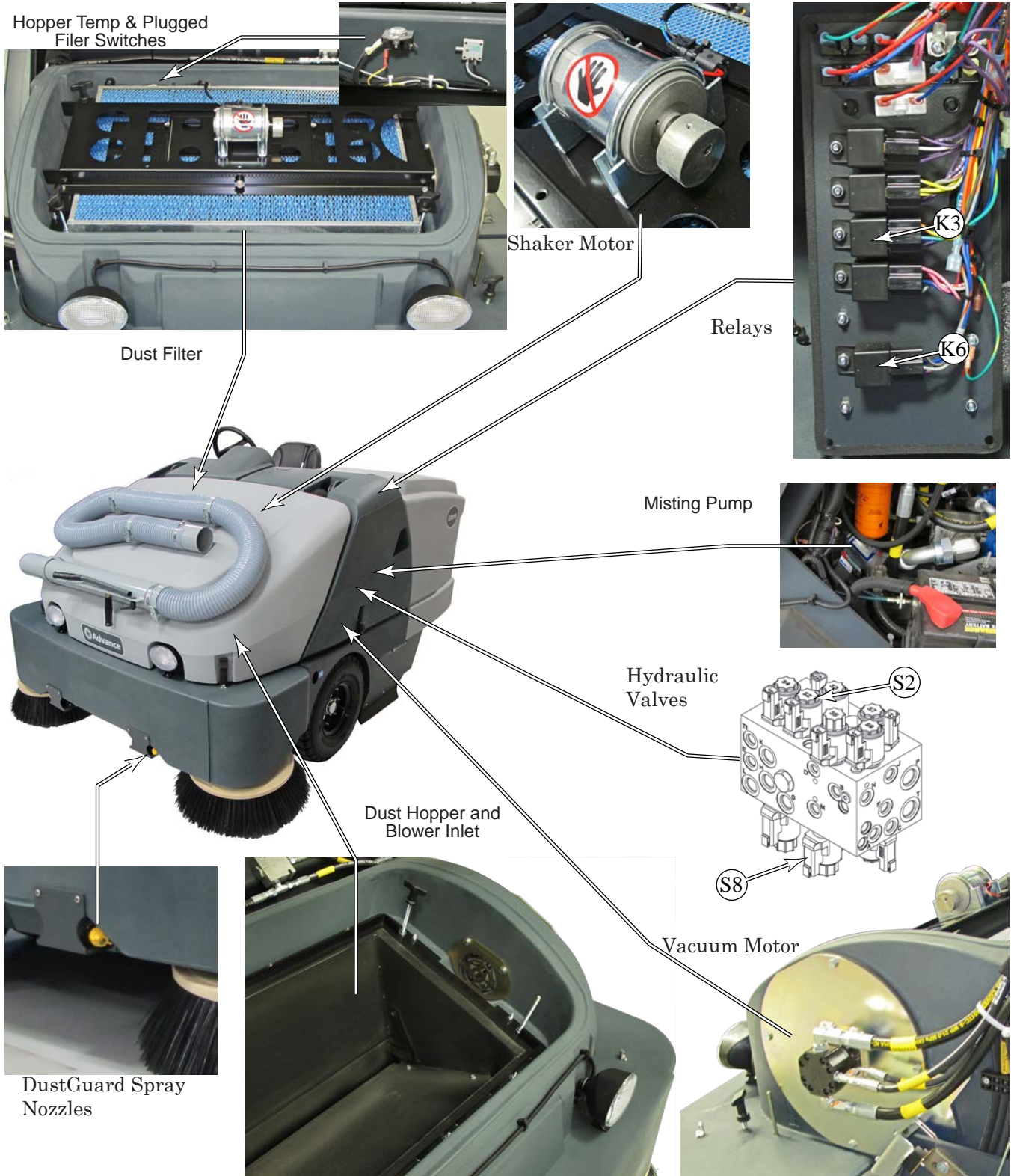

Maintenance and Adjustment

Dustguard Spray Nozzle Cleaning

1. For easier access to the nozzles, raise the hopper slightly.
2. Place a container underneath the nozzles to catch any water that may leak from the hoses.
3. While holding the nozzle body (4) from turning (7/8" wrench) rotate the nozzle cap (1) 1/4-turn and remove the nozzle cap, nozzle tip (2), and check valve strainer (3).
4. Rinse the nozzle cap, spray nozzle and check valve strainer in clean water to remove any accumulated dirt or sediment. If necessary, rinse or soak the components in vinegar or other commercial cleaner to remove any mineral deposits.
5. Reassemble the nozzles by following the above steps in reverse order.

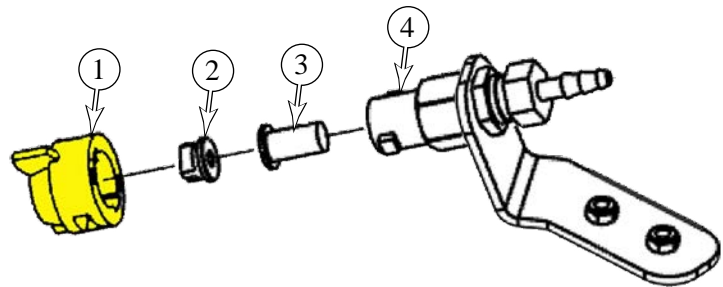
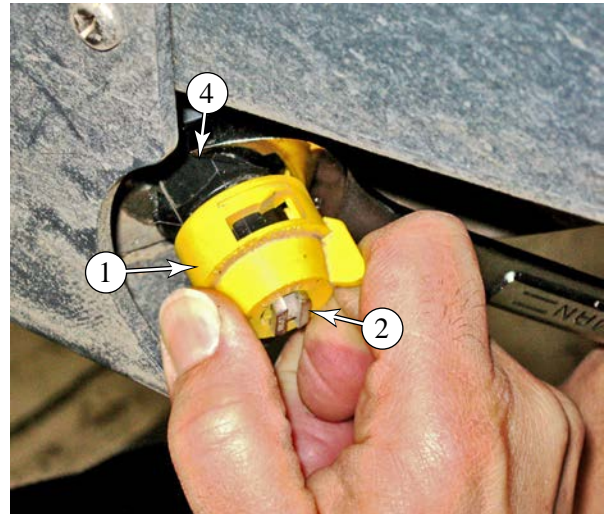

Dust Control Filter Cleaning



Caution! Avoid breathing dust or getting debris in your eyes. Wear safety glasses and respiratory protection when cleaning the filter. Clean the filter in a well ventilated area.

1. Lift the hopper cover and prop it open with the cover prop rod.
2. Disconnect the Shaker Motor Electrical Connector.
3. Remove the 4 thumbnuts (5) that secure the shaker frame (6), and lift the shaker frame off the filter (7).
4. Lift the filter out of the machine.
5. Inspect the top of the dust control filter for damage. A large amount of dust on top of the filter is usually caused by a hole in the filter or a damaged filter gasket.
6. Vacuum the underside (dirty side) of the filter to remove loose debris.
7. Loosen additional stuck debris by gently tapping the filter against a flat surface, such as a workbench or floor.
8. If additional cleaning is necessary, you may use compressed air (less than 100 psi), but do so with caution. Direct the air through the filter from the clean side to the dirty side.
9. When replacing the filter, make sure the flow direction arrow is pointing up.

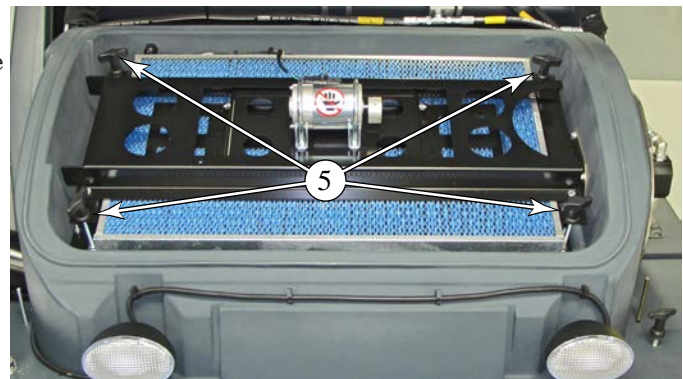

Troubleshooting

Dust Control Vacuum Motor will not Run

The dust control hydraulic solenoid valve is normally-active (on when no power is present). So the most likely cause is a hydraulic problem, but may also be electrical. Isolate the cause using the following steps:



Note: In the decision tree below, all function prerequisites are assumed to be true for the function to normally be active. For example, the engine is assumed to be at run-speed and the main broom is active.

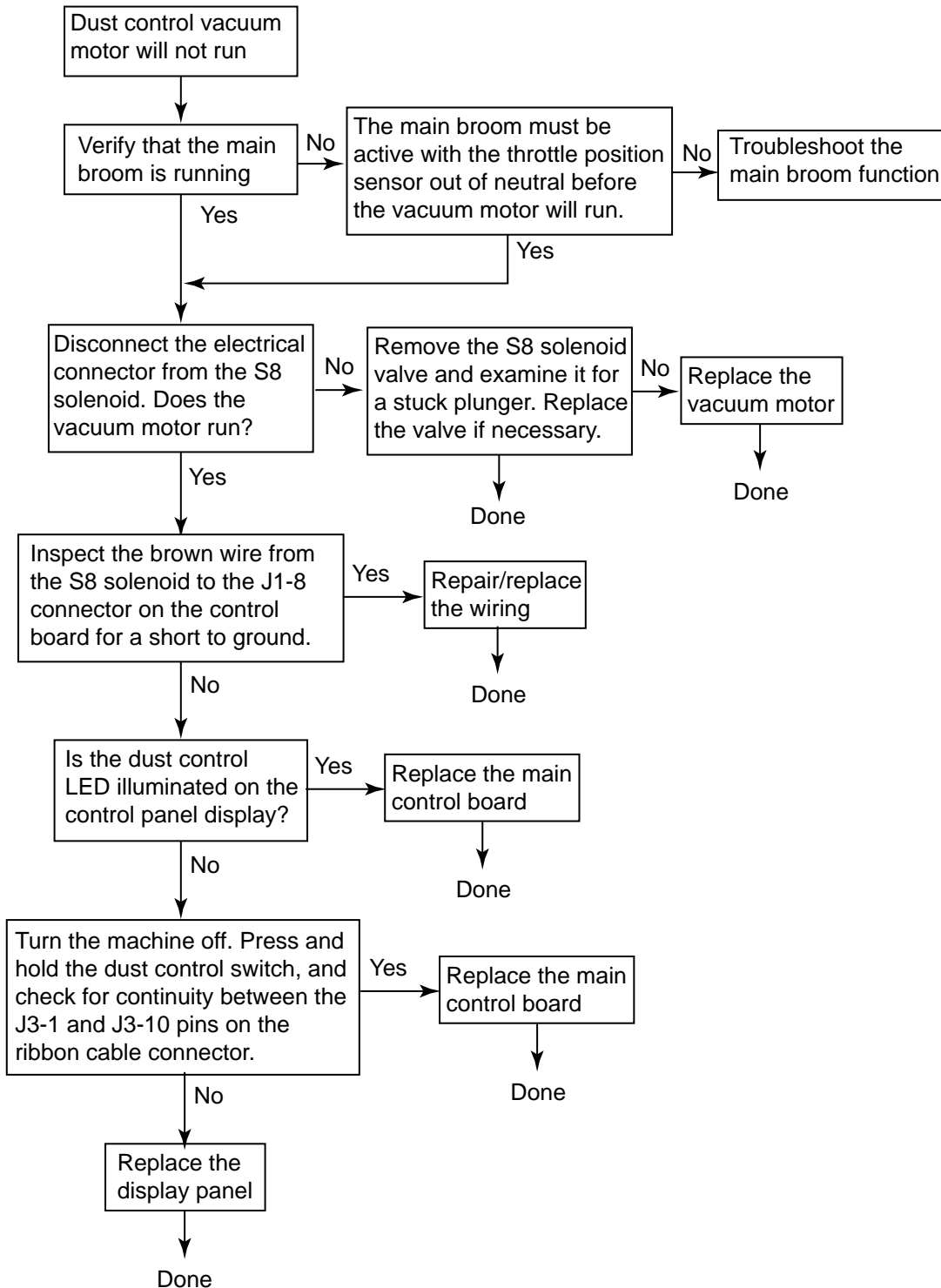

Dust Control Vacuum Motor will not Shut Off

The dust control vacuum motor should turn off while the shaker is running or when the dust control system is disabled. Failure to turn off is an indication that the bypass solenoid valve is not being activated. The most likely cause is electrical, but may also be from a stuck solenoid valve. Use the following steps to isolate the cause:



Note: In the decision tree below, all function prerequisites are assumed to be true for the function to normally be active.

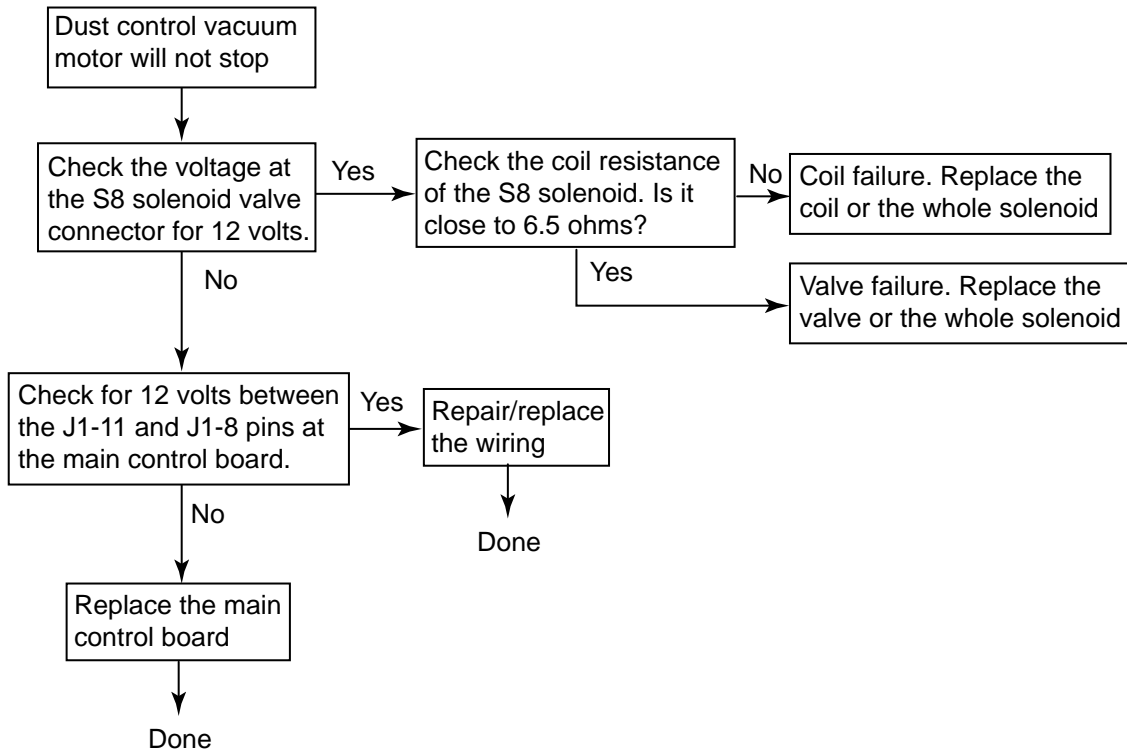

Shaker Motor will not Run

If the shaker motor does not operate when the switch is pressed, use the follow steps to isolate the cause:



Note: In the decision tree below, all function prerequisites are assumed to be true for the function to normally be active.

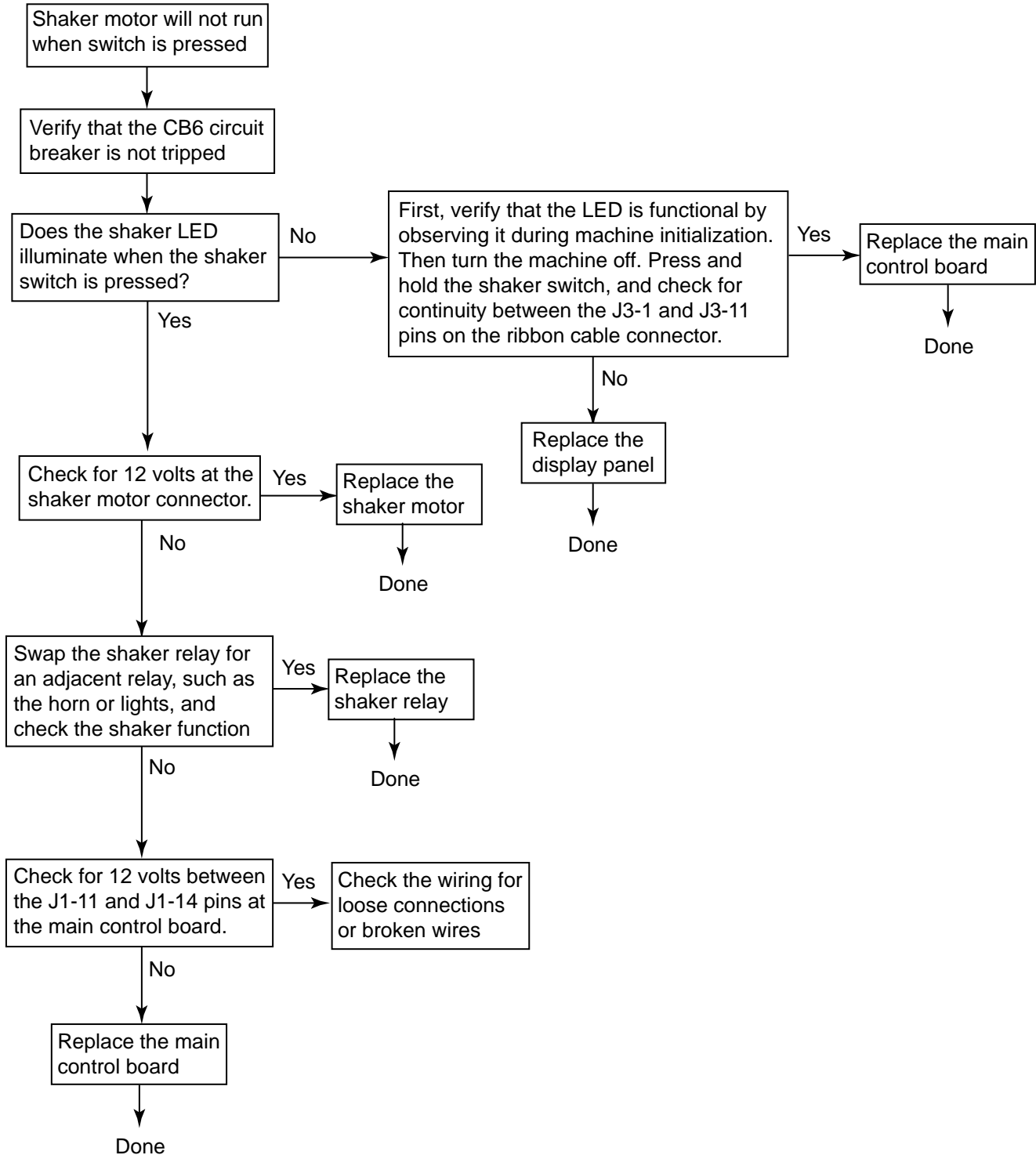

Misting Pump will not Run

Operation of the misting pump relay coil has two dependencies. The misting pump switch must be closed for positive voltage at the relay coil, and the controller output for the side broom provides the negative voltage at the coil. If the side broom is functional and in motion, then the controller is known to not be the cause of the problem. If the side broom is not functioning, then troubleshoot the side broom first. Use the following steps to isolate the cause.

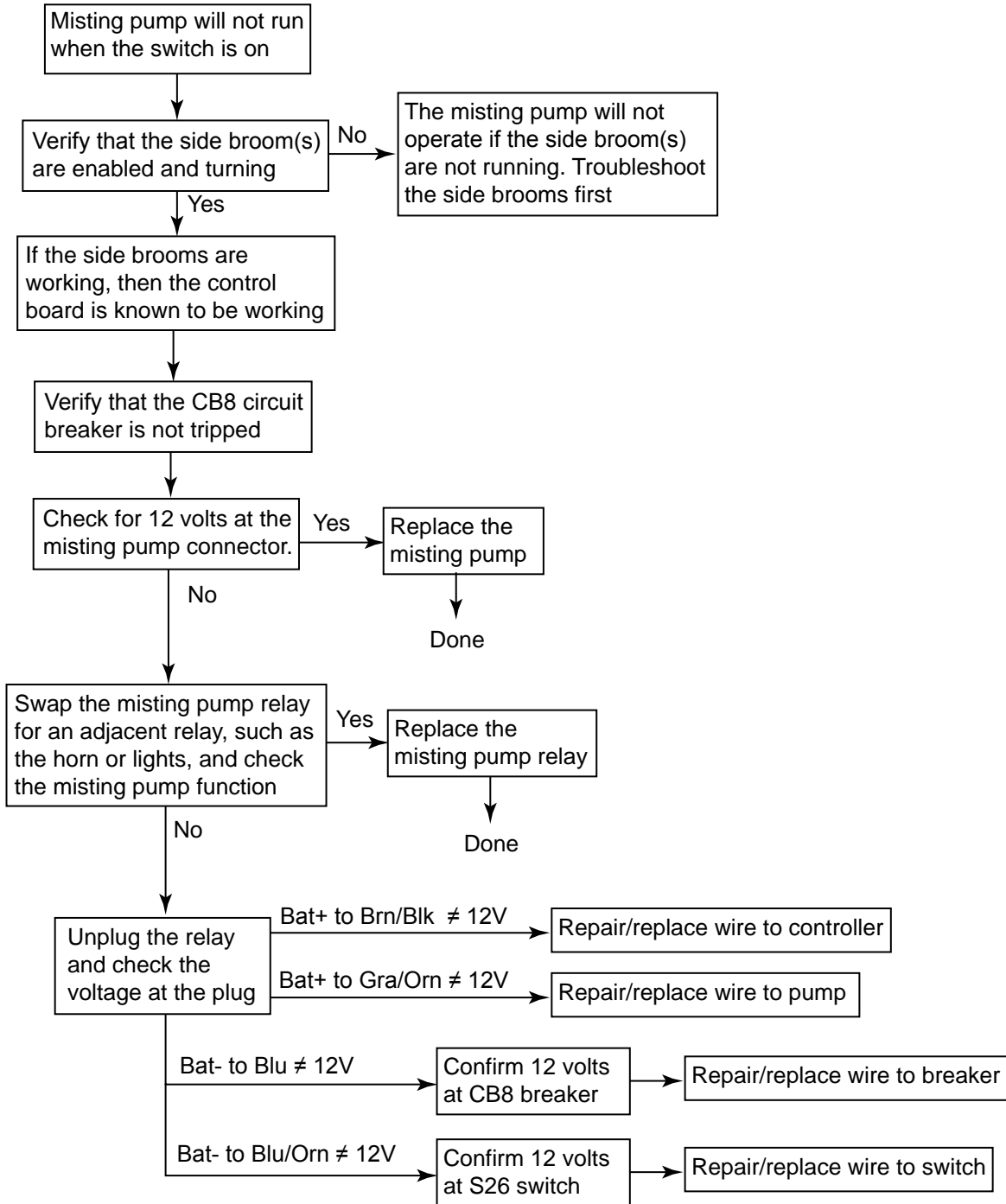

Specifications

Parameter	Range
Misting pump relay coil resistance	• 85 Ω
Shaker motor relay coil resistance	• 90 Ω
Dust control (misting) valve coil resistance	• 85 Ω
Dust control (vacuum) valve coil resistance	• 6 Ω

Electrical System

Functional Description

Overview

The electrical system consists of the switches, gauges and relays on the instrument panel, the circuit breakers, the drive pedal rotary sensor and the battery. Note that the hydraulic solenoid valves and engine electrical components are described in the corresponding sections of this manual.

Gauge Panel Assembly

The gauge panel assembly panel includes the **Fuel Level Gauge** (gas and diesel machines only), **Hour Meter**, **Panel Assembly**, **A2 Main Machine Controller** and the **Starter Switch**.

The **Panel Assembly** contains the touch-pad membrane switches and indicators that allow the Operator to enable and disable the sweeping functions, raise and lower the hopper, open and close the hopper door, control the engine speed, sound the horn, and switch the headlights on and off.

The **A2 Main Machine Controller** is a computerized controller that receives inputs from the membrane switches and the system components, and provides output voltage to the various solenoid valves, relays, **Panel Assembly** indicators, etc.

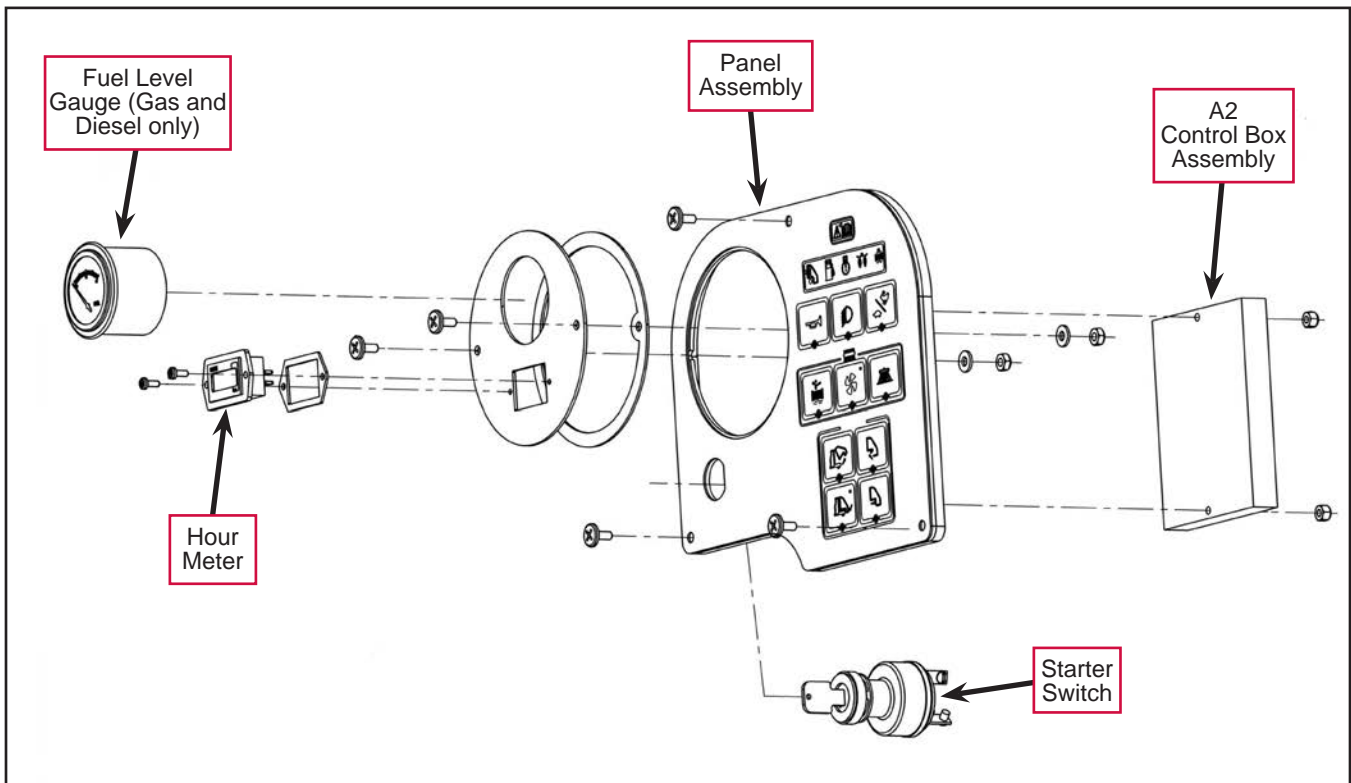

Circuit Breaker Panel Assembly

The **Circuit Breaker Panel** assembly is mounted below the instrument panel hopper switches and includes the **Circuit Breakers** and the **SPDT Relays**.

Note that diesel models have an additional **SPDT Relay**.

Models equipped with the DustGuard™ system have an additional 10-amp **Circuit Breaker** and **SPDT Relay** for the misting pump.

Models equipped with the optional signal lights will have an additional 20-amp **Circuit Breaker** and **SPDT Relay**.

Models equipped with the cab HVAC option will have an additional 20-amp **Circuit Breaker** and two additional **SPDT Relays**.

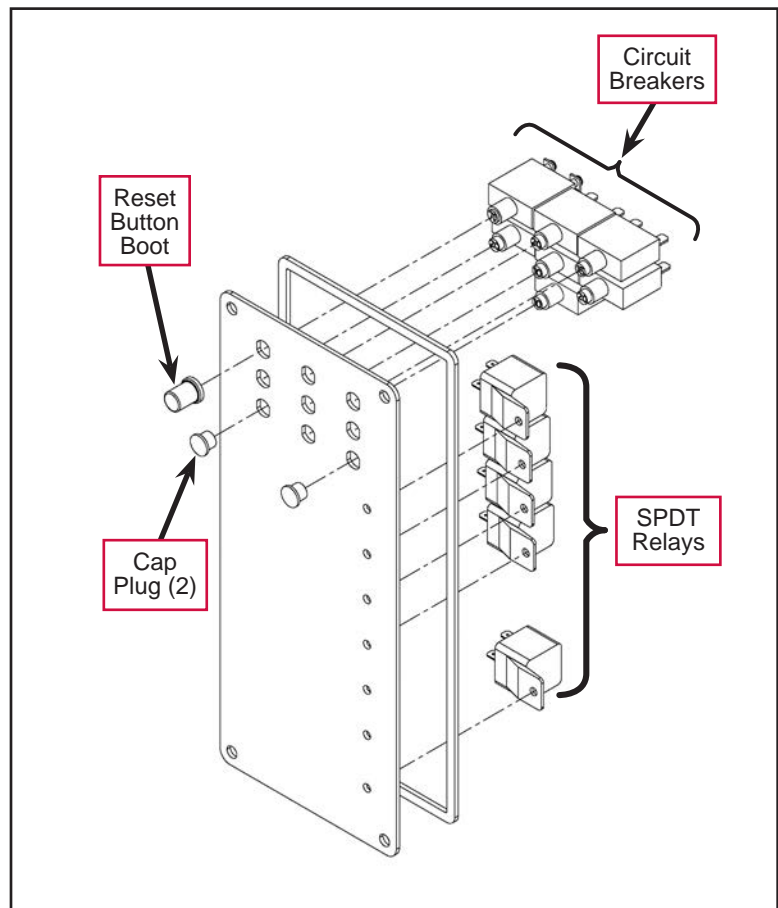

Wire Identification

Wires are color coded and have connector information printed near each end of the wire.

- In the bottom left photo, one side of the blue/black wire goes to the Shaker Relay, **K3**. The other side of the wire goes to terminal **2** on Circuit Breaker **CB6**.
- In the bottom right photo, one side of the gray/blue wire goes to pin **J1-17** on the A2 Main Machine Controller. The other side of the wire goes to terminal **K** on connector **X2**.

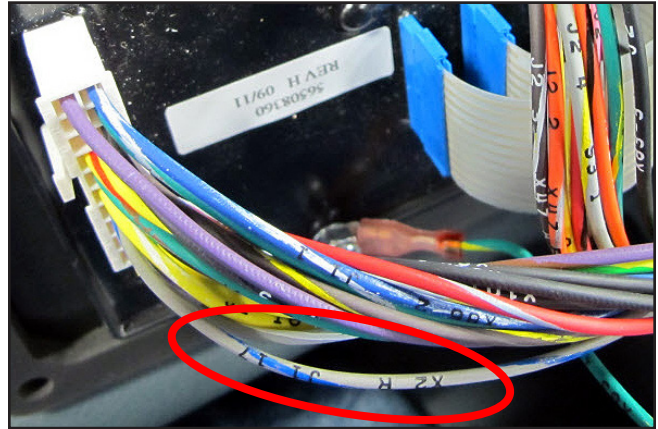
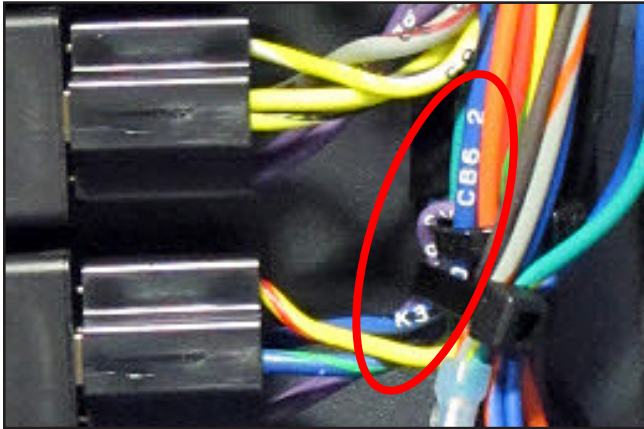

Rotary Sensor

The **Rotary Sensor** (referred to as the **Drive Pedal Sensor**, 5K Ohm on the **Wiring Diagram**) is a rotary potentiometer that is connected to the **Lever Weldment**. As the **Lever Weldment** rotates to drive the machine forward or backward, the resistance through the **Rotary Sensor** changes proportionately.

The machine is programmed so the **Rotary Sensor** is in its “dead-band” resistance range when the **Lever Weldment** is in the neutral position.

The A2 Main Machine Controller must detect the **Rotary Sensor** in its dead-band range before the engine can be started.

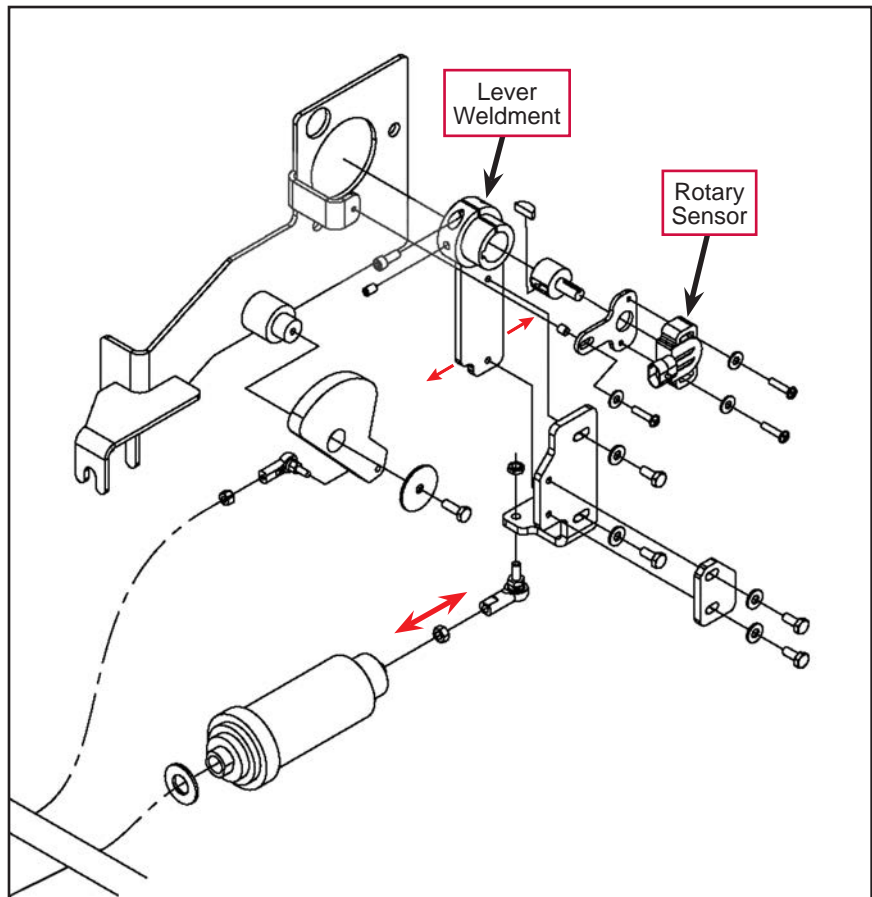

Seat Switch Circuit Description

The **Seat Switch S21** and **.5 sec. Delay Relay K12** are installed on Nilfisk machines only and will shut off the engine if the Operator leaves the seat for more than one-half second.

Machines also equipped with the Litter Vac Kit option have a parking **Brake Switch S22** and **Seat Relay K11** that will bypass the **Seat Switch S21** when the parking brake is engaged. This allows the engine to run to operate the Litter Vac with the Operator off of the seat.

The seat switch and brake switch circuits work as follows:

- The ignition switch provides positive voltage to terminal **15** on the **.5 sec. Delay Relay K12**. Terminal **53M** on the **K12** is connected to battery ground.
- When the Operator sits on the seat and closes the **Seat Switch S21**, this provides positive voltage to terminal **T** on **K12**.
- When **K12** sees voltage at terminal **T** it energizes and sends the voltage available on terminal **15** through terminal **53s** to circuit breaker **CB5**, then to the engine controller. Without this power to the engine controller the engine will not run. Note that:
 - If the voltage from the **Seat Switch S21** to terminal **T** on **K12** is interrupted for one-half second or less, **K12** will continue to send voltage through terminal **53s** to circuit breaker **CB5** to allow the engine to continue to run.
 - If the voltage from the **Seat Switch S21** to terminal **T** on **K12** is interrupted for more than one-half second, **K12** will cut off the voltage to terminal **53s** and circuit breaker **CB5** to shut off the engine.
- If the machine is equipped with the Litter Vac Kit, engaging the parking brake will close the **Brake Switch S22**.
 - On machines equipped with the light option, the **Brake Switch S22** gets positive voltage from relay **K5**.
 - On machines not equipped with the light option, the **Brake Switch S22** gets positive voltage from the ignition switch.
- The closed **Brake Switch S22** provides positive voltage to energize the **Seat Relay Coil K11**, which closes the contacts on the **Seat Relay K11**. The **Seat Relay K11** contacts provide positive voltage to terminal **T** on **K12**, bypassing the **Seat Switch S21**. **K12** sends voltage through terminal **53s** to circuit breaker **CB5** and the engine controller to allow the engine to run with the Operator off of the seat.

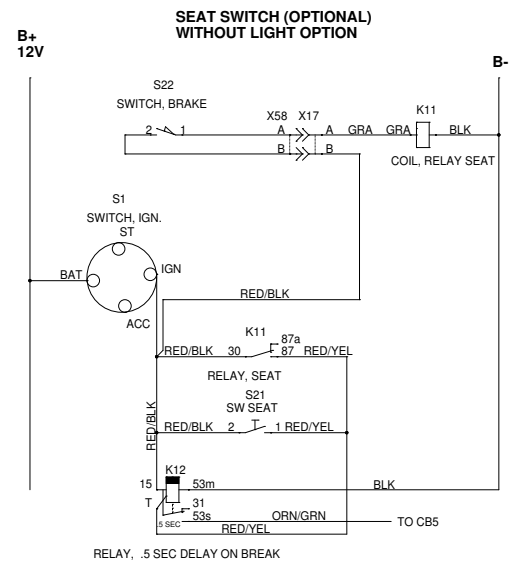
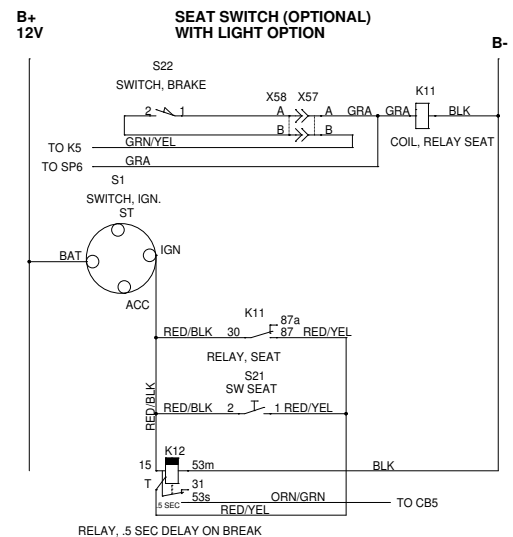

Component Locations

The following components are included in this section:

- Battery
- Instrument Panel Assembly
- Circuit Breakers
- SPDT Relays
- K11 Seat Relay Coil and K12 Timer Relay
- S22 Brake Switch
- Rotary Sensor

Battery

The **Battery** is mounted on the left-hand side of the machine frame, just behind the left front wheel.

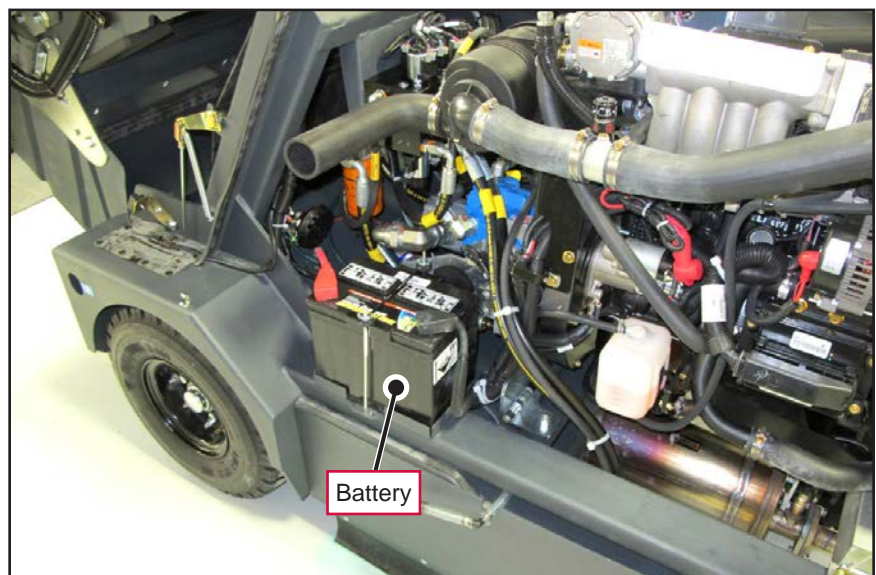

Instrument Panel Assembly

The **A2 Main Machine Controller**, **Hour Meter** and **Starter Switch** are mounted on the **Panel Assembly**. Note that Gas and Diesel models also have a Fuel Level Gauge mounted on the **Panel Assembly** adjacent to the **Hour Meter**.

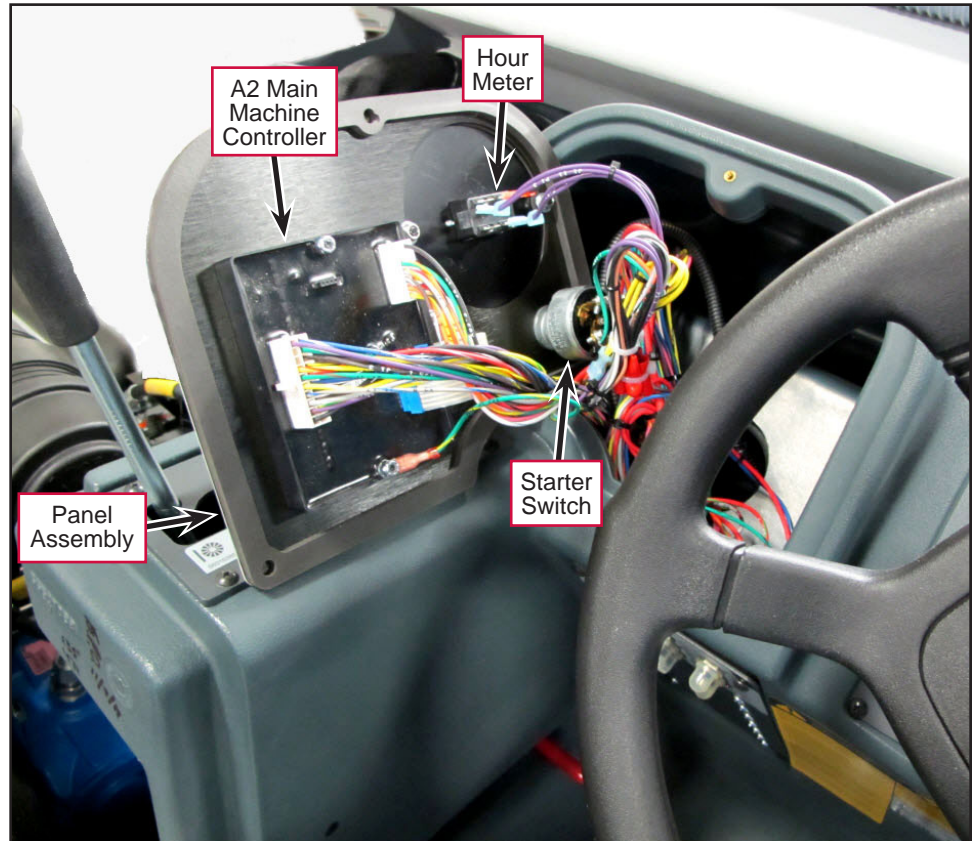

Circuit Breakers

The machine **Circuit Breakers** are mounted on the **Circuit Breaker Panel**, located below the instrument panel hopper switches.

Note that additional **Circuit Breakers** are installed on machines equipped with the optional DustGuard™ system, optional signal lights and the cab HVAC option.



SPDT Relays

The **SPDT** (single pole, double throw) **Relays** are mounted on the back of the **Circuit Breaker Panel**, located below the instrument panel hopper switches.

Note that diesel models have an additional **SPDT Relay**.

Additional **SPDT Relays** are also installed on machines equipped with the optional **DustGuard™** system, optional signal lights and the cab HVAC option.

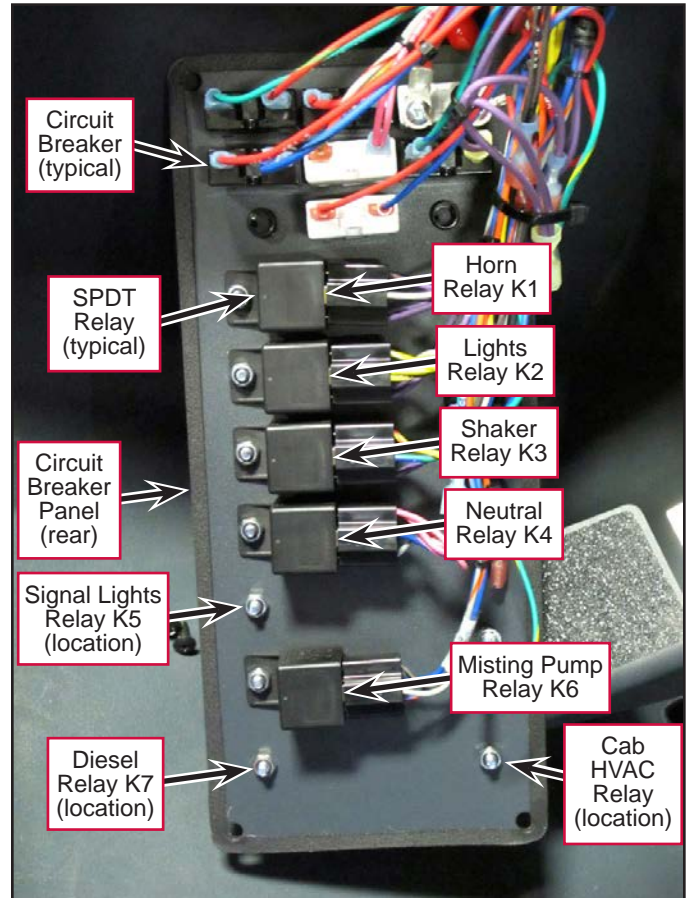
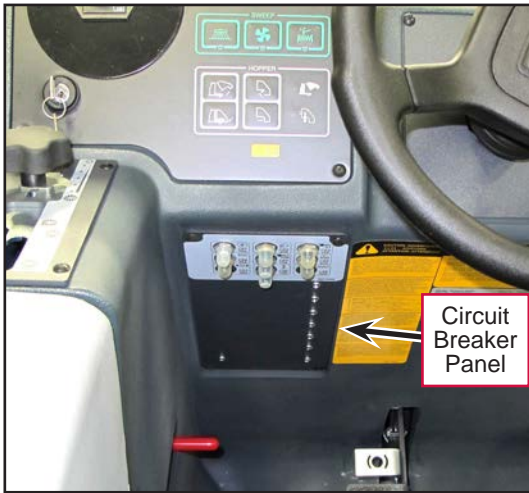

K11 Seat Relay Coil and K12 Timer Relay (seat switch option only)

The **K11 Seat Relay Coil** and **K12 Timer Relay** are mounted on the front of the frame behind the Hopper and rubber cover.

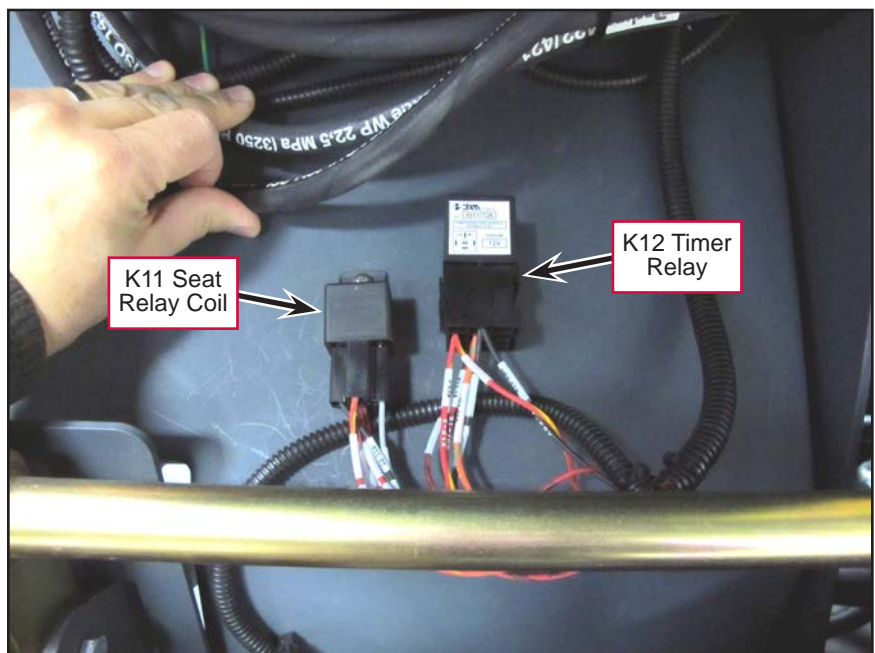

S22 Brake Switch (seat switch option only)

The **S22 Brake Switch** is located adjacent to the **Brake Pedal** and is actuated when the parking brake is engaged.

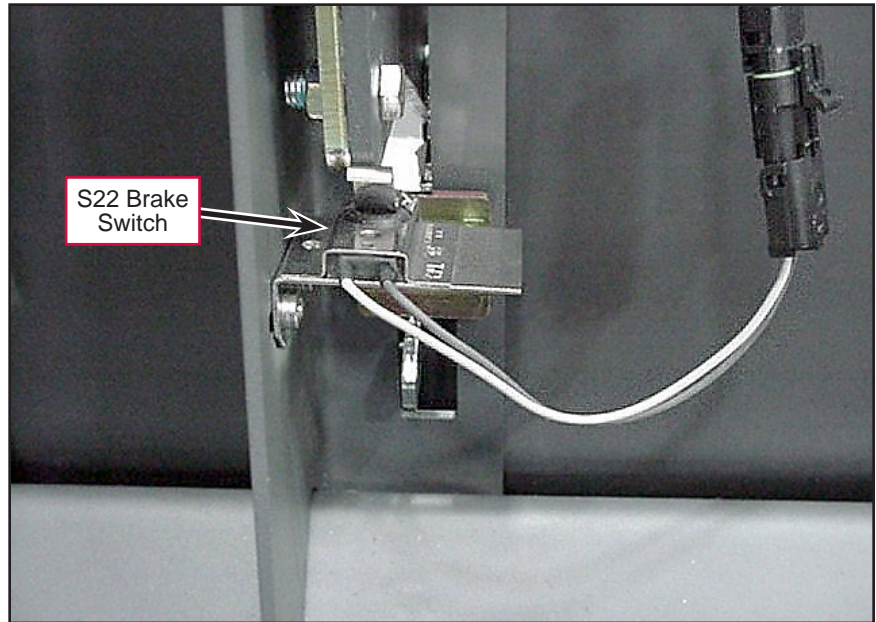

Rotary Sensor

The **Rotary Sensor** is fastened to the mount plate, which is mounted to the **RTN Bracket**.

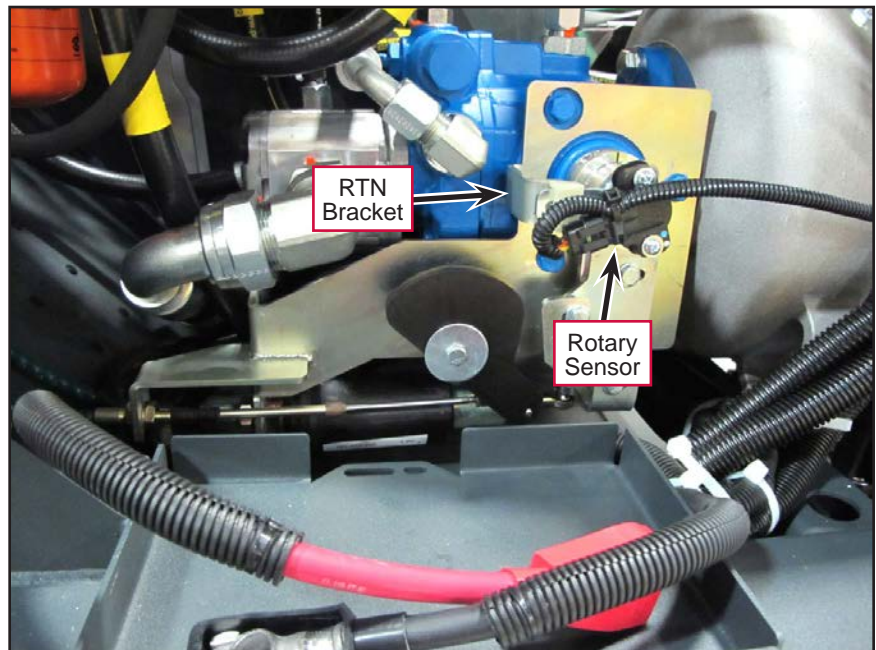

Electrical Connectors

The following tables list the machine components and their assigned connector or relay, and the individual connector pin-out assignments. The **Connector Pin-out Assignments** tables include connector illustrations to help you identify the various connectors on the machine.

If you are viewing this document on a computer, you can search for the component name or connector ID to find the pin-out assignments. However, if you are viewing a paper copy, it will be easier for you to find the correct pin-out assignment table for a particular component if you know the connector ID. To get the connector ID, find the component name from the Wiring Harness Diagram, then use the **Component to Connector ID Look-up Table** below to find the corresponding connector ID.

Component to Connector ID Look-up Table

Component Name	Connector ID
A2 Main Machine Controller	J1
A2 Main Machine Controller	J2
Engine System	X1
Engine System	X2
Seat Switch, S21	X12
Brake Switch, S22	X17
Shaker Motor	X40
Back Up Alarm (optional)	X46
Strobe (optional)	X76
Fuel Pump	X37
Hopper Interlock Switch, S4	X50
Main Broom Switch, S2	X52
Drive Pedal Sensor, 5K Ohm	X47
L1 - Hopper Door Close/Open Valve, S1	X86
L2 - Main Broom Valve, S2	X96
L3 - Side Broom Valve, S3	X97
L4 - Dust Control Valve, S4	X98
L5 - Hopper Up/Down Valve, S5	X99
L6 - Hopper Up/Bypass Valve, S6	X100
L7 - Hopper Door Valve, S7	X101
L8 - Dust Control Bypass Valve, S8	X102
L9 - Hopper Lower Valve, S9	X103

Component to Relay ID Look-up Table

Component Name	Relay ID
Horn Relay	K1
Lights Relay	K2
Shaker Relay	K3
Neutral Relay	K4
Signal Lights Relay	K5
Seat Relay	K11
0.5 Second Delay Relay	K12

Connector Pin-out Assignments

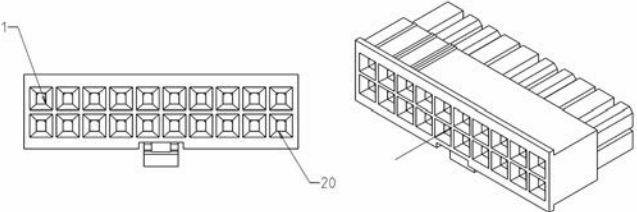
Connector J1, A2 Main Machine Controller – Molex Mini Fit Jr. 39012205		
		
Pin#	Component Assignment	Wire Color
J1-1	Hopper Open/Close Solenoid Valve, S1	BLU/WHT 18-1
J1-2	Main Broom Solenoid Valve, S2	GRN/GRA 18-1
J1-3	Side Broom Solenoid Valve, S3	BRN/BLK 18-1
J1-4	Dust Control Solenoid Valve, S4	BRN/YEL 18-1
J1-5	Hopper Up/Down Solenoid Valve, S5 Compressor Relay, K10 (optional)	RED/GRA 18-1
J1-6	Hopper Up/Bypass Solenoid Valve, S6	BLU/GRA 18-1
J1-7	Hopper Open Solenoid Valve, S7	BLK/WHT 18-1
J1-8	Dust Control Bypass Solenoid Valve, S8	BRN 18-1
J1-9	Hopper Lower Solenoid Valve, S9	YEL/GRN 18-1
J1-10	Ground	BLK 18-1
J1-11	Acc. Input	VIO 18-3
J1-12	Not Used	–
J1-13	Not Used	–
J1-14	Shaker Relay, K3	YEL/RED 18-1
J1-15	Back Up Alarm (optional)	GRN/BRN 18-1
J1-16	Lights Relay, K2	YEL/WHT 18-1
J1-17	Throttle Output to Engine System (+12 V for High Speed)	GRA/BLU 18-1
J1-18	Neutral Relay, K4	GRA/WHT 18-1
J1-19	Horn Relay, K1	VIO/BRN 18-1
J1-20	Ground	BLK 18-2

Connector J2, A2 Main Machine Controller – Molex Mini Fit Jr. 39012145-14

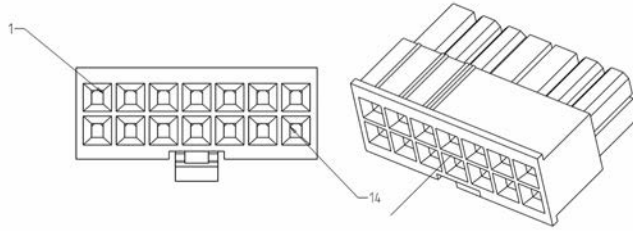

Pin#	Component Assignment	Wire Color
J2-1	Drive Pedal Sensor, 5K Ohm (3), 5v Reference	YEL/GRA 18-1
J2-2	Drive Pedal Sensor, 5K Ohm (2), Wiper	ORN/GRA 18-1
J2-3	Drive Pedal Sensor, 5K Ohm (1), Ground	BRN/WHT 18-1
J2-4	Low LP Pressure Switch, S3	GRA/YEL 18-1
J2-5	Check Engine Output from Engine System	GRN/YEL 18-1
J2-6	Glow Plug Indicator Light (diesel only)	GRN/RED 18-1-
J2-7		-
J2-8	Dust Control Filter Switch, S5 (optional)	WHT/GRA 18-1
J2-9	Hopper Interlock Switch, S4	RED/BLK 18-1
J2-10	140° F. Hopper Temperature Switch, S6 (optional)	YEL/VIO 18-1
J2-11	Ign. Input	PINK 18-1
J2-12	Main Broom Switch, S2	ORN/BLK 18-1
J2-13		-
J2-14	Ground	BLK 18-3

Horn Relay, K1 – Bosch 3334485007

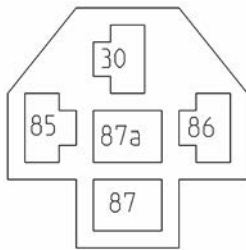

Pin#	Wire Color
85	VIO/BRN 18-1
87	WHT/YEL 18-1
87a	-
30	VIO 16-2
30	VIO 16-3
86	VIO 16-2
86	VIO 16-1

Lights Relay, K2 – Bosch 3334485007

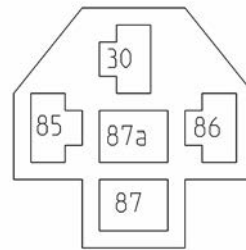

Pin#	Wire Color
30	GRA/RED 14-1
85	YEL/WHT 18-1
87a	-
86	VIO 16-3
86	VIO 16-4
87	YEL/BLK 16-1
87	YEL/BLK 16-2

Shaker Relay, K3 – Tyco 1393310-4

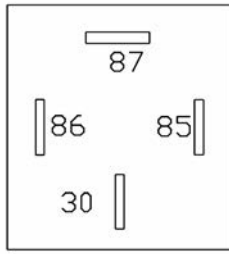

Pin#	Wire Color
30	BLU/BLK 12-1
85	YEL/RED 18-1
87	BLU/GRN 12-1
86	VIO 18-1
86	VIO 16-4

Neutral Relay, K4 – Bosch 3334485007

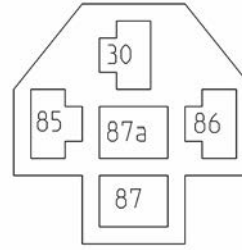

Pin#	Wire Color
30	RED/GRN 16-1
86	GRA/WHT 18-1
87	–
87a	BLU/PINK 16-1
85	PINK 16-2
85	PINK 16-3

Signal Lights Relay, K5 – Bosch 3334485007

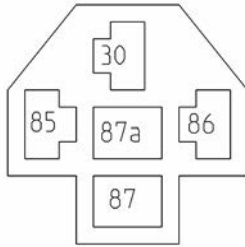

Pin#	Wire Color
30	ORN 16-1
85	BLK 18-10
85	BLK 18-25
87a	–
87	GRN/YEL 16-3
87	GRN/YEL 16-4
86	VIO 18-1
86	VIO 18-2

Seat Relay, K11 – Bosch 3334485007

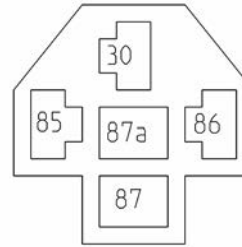

Pin#	Wire Color
30	RED/BLK 18-5
30	RED/BLK 18-4
30	RED/BLK 18-3
85	GRA 18-6
86	BLK 18-39
87	RED/YEL 18-2

**0.5 Second Delay Relay, K12 – Cobo
30-16-07811**

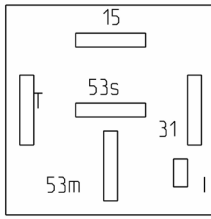

Pin#	Wire Color
15	RED/BLK 18-2
15	RED/BLK 18-3
53M	BLK 18-38
53M	BLK 18-39
53s	ORN/GRN 16-1
T	RED/YEL 18-1
T	RED/YEL 18-2

Engine System Connector, X1 – Delphi 15326868

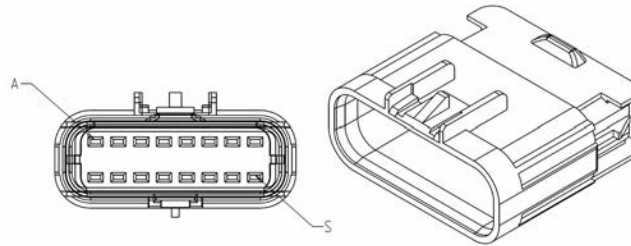

Pin#	Component Assignment	Wire Color
A	Ignition Switch Input to A3	PINK 16-4
B	Alt. Excite on A3	PINK 16-7
C	Fuel Pump Output	BLK/RED 16-1
D	Fuel Pump Output	PINK/YEL 16-1
E		–
F	Starter Command	BLU/PINK 16-1
G	MIL Output (switched ground)	GRN/YEL 18-1
H		–
J		–
K		–
L		–
M		–
N		–
P		–
R		–
S		–

Engine System Connector, X2 – Delphi 15326863

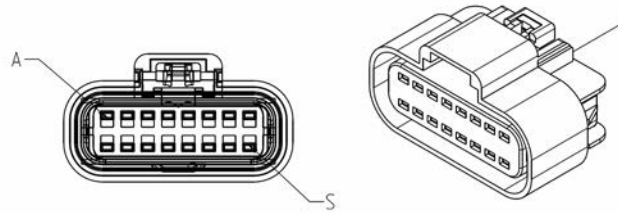

Pin#	Component Assignment	Wire Color
A		–
B		–
C		–
D		–
E		–
F	Coolant Temperature Output	TAN 18-1
G		–
H		–
J		–
K	Throttle Input (12V for high)	GRA/BLU 18-1
L		–
M		–
N		–
P		–
R		–
S		–

Two-pin Connectors – Delphi 12015792

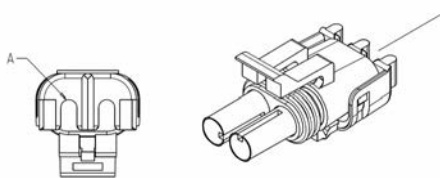

ID	Name	Pin#	Wire Color
X12	Seat Switch, S21	A	RED/YEL 18-1
		B	RED/BLK 18-4
X17	Brake Switch, S22	A	RED/BLK 18-5
		B	GRA 18-6
X40	Shaker Motor	A	BLU/GRN 14-1
		B	BLK 14-1
X46	Back Up Alarm (optional)	A	VIO 18-17
		B	GRN/BRN 18-1
X76	Strobe (optional)	A	VIO 18-16
		B	BLK 18-22

Two-pin Connectors – Delphi 12010973

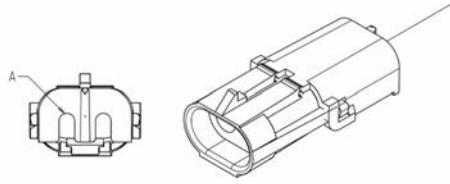

ID	Name	Pin#	Wire Color
X37	Fuel Pump	A	PINK/YEL 16-1
		B	BLK/RED 16-1
X50	Hopper Interlock Switch, S4	A	RED/BLK 18-1
		B	BLK 18-6 18-6
X52	Main Broom Switch, S2	A	ORN/BLK 18-1
		B	BLK 18-7

Three-pin Connector – Delphi 12162182

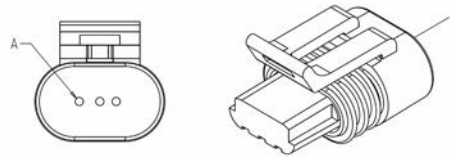

ID	Name	Pin#	Wire Color
X47	Drive Pedal Sensor, 5K Ohm	A	BRN/WHT 18-1
		B	ORN/GRA 18-1
		C	YEL/GRA 18-1

Two-pin Connectors – Deutsch DT06-2S

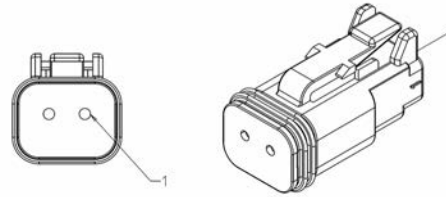

ID	Name	Pin#	Wire Color
X86	L1 - Hopper Door Close/Open Valve, S1	1	VIO 18-4
		2	BLU/WHT 18-1
X96	L2 - Main Broom Valve, S2	1	VIO 18-7
		2	GRN/GRA 18-1
X97	L3 - Side Broom Valve, S3	1	VIO 18-8
		2	BRN/BLK 18-2
X98	L4 - Dust Control Valve, S4	1	VIO 18-10
		2	BRN/YEL 18-1
X99	L5 - Hopper Up/Down Valve, S5	1	VIO 18-5
		2	RED/GRA 18-1
X100	L6 - Hopper Up/Bypass Valve, S6	1	VIO/18-11
		2	BLU/GRA 18-1
X101	L7 - Hopper Door Valve, S7	1	VIO 18-12
		2	BLK/WHT 18-1
X102	L8 - Dust Control Bypass Valve, S8	1	VIO 18-13
		2	BRN 18-1
X103	L9 - Hopper Lower Valve, S9	1	VIO 18-23
		2	YEL/GRN 18-1

Troubleshooting

Problem	Cause	Correction
No power to the machine	Discharged battery.	Check the battery voltage and charge as necessary.
	Poor battery connection(s).	Check the battery cables, terminals and connections and tighten/repair/replace as necessary.
	Battery needs to be replaced.	Perform a load test on the battery and replace if necessary.



Note: Refer to the individual machine system sections for electrical troubleshooting procedures.

Specifications

Component	Specifications
SPDT Relay (R1, R2, R3, R4, R5 and R6)	Coil Operating Current – 160 mA
	Coil Resistance – 85 ± 5 ohms
	Pull-in Voltage – 8 volts
	Release Voltage – 1.0 to 5.0 volts

Wiring Diagrams, p/n 56382530, Rev. D



Note: Refer to the individual machine system sections for the system ladder diagrams and circuit descriptions.

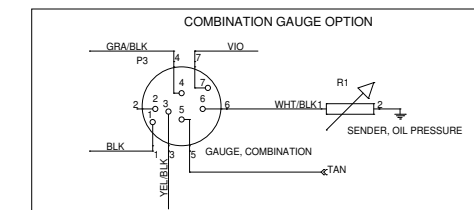
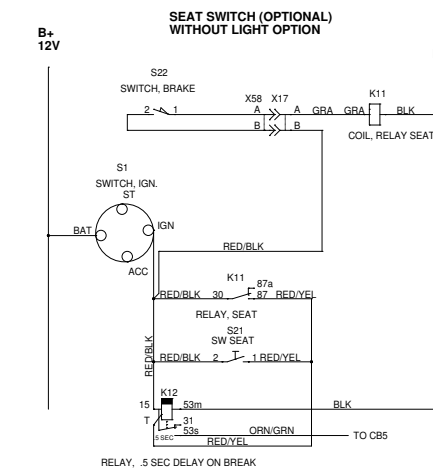
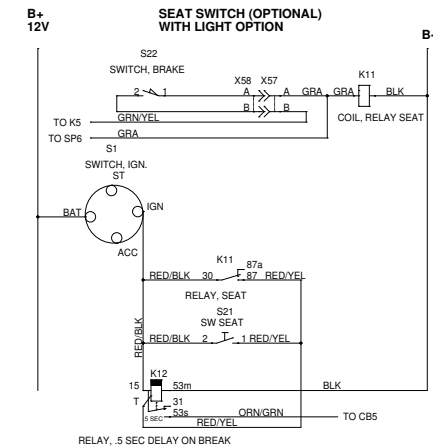
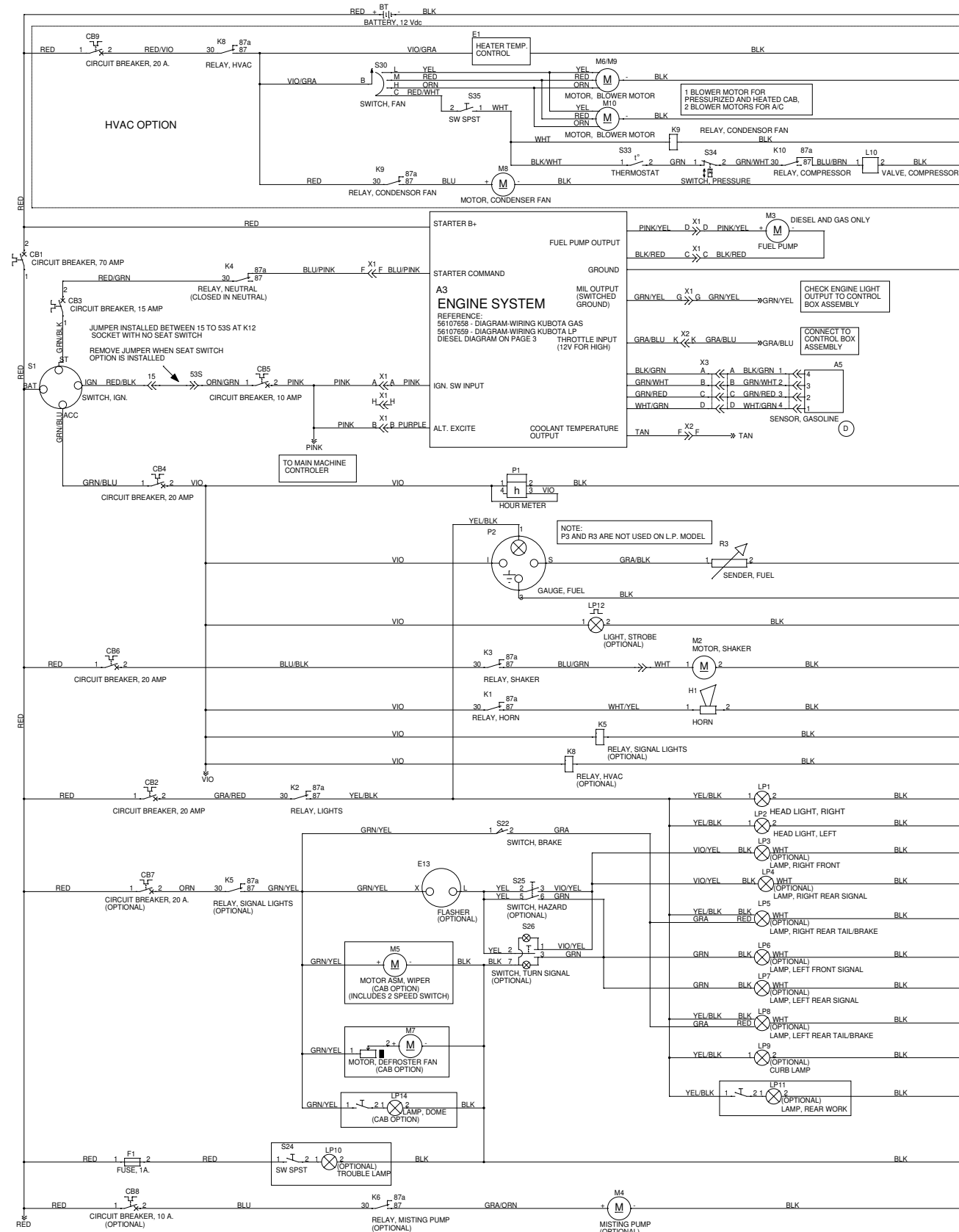

Notes: 1. Reference 56382531 Wiring Harness Diagram

Wiring Diagrams, p/n 56382530, Rev. D, sheet 2 of 3

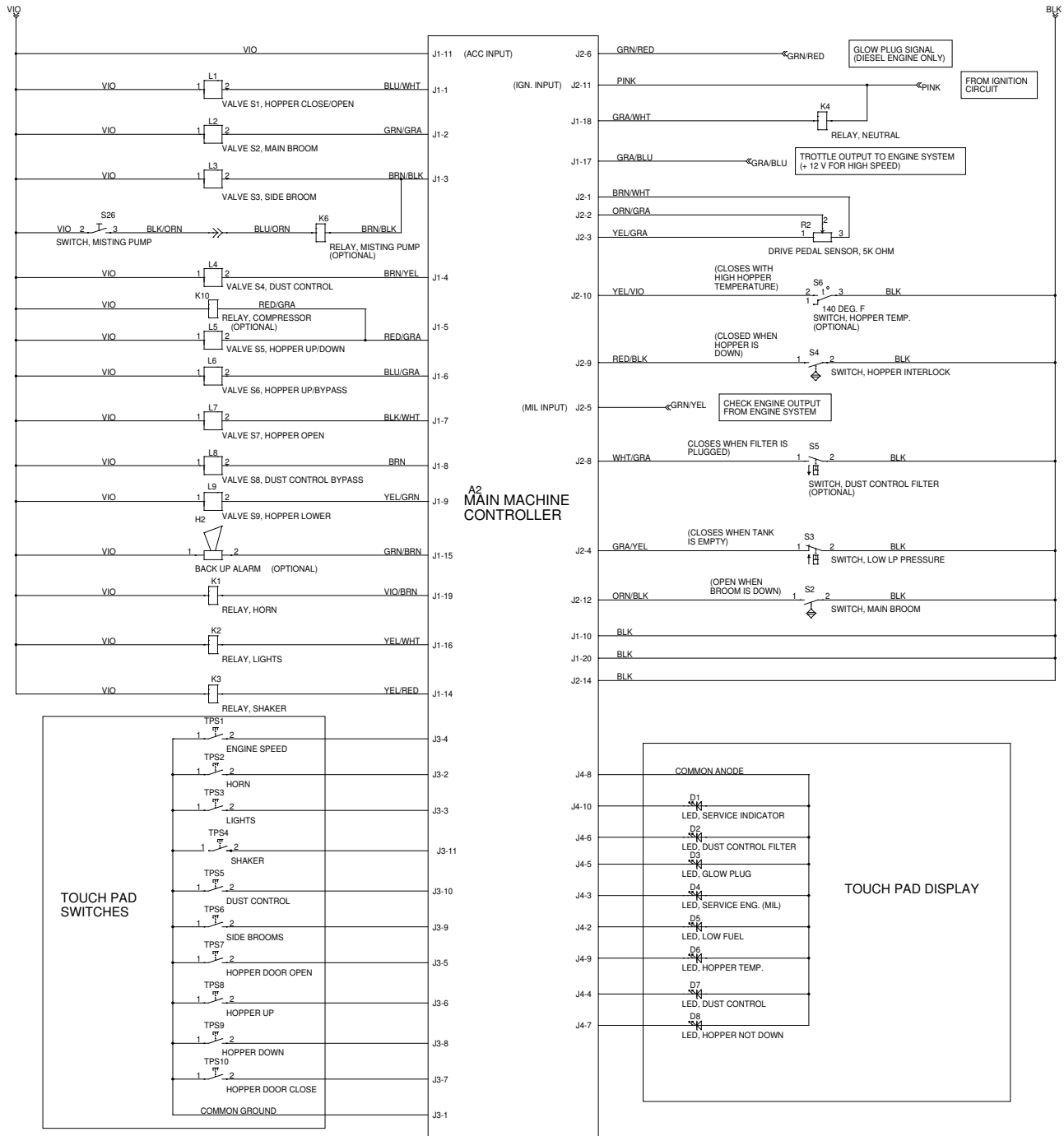

Wiring Diagrams, p/n 56382530, Rev. D, sheet 3 of 3

KUBOTA DIESEL ENGINE SYSTEM

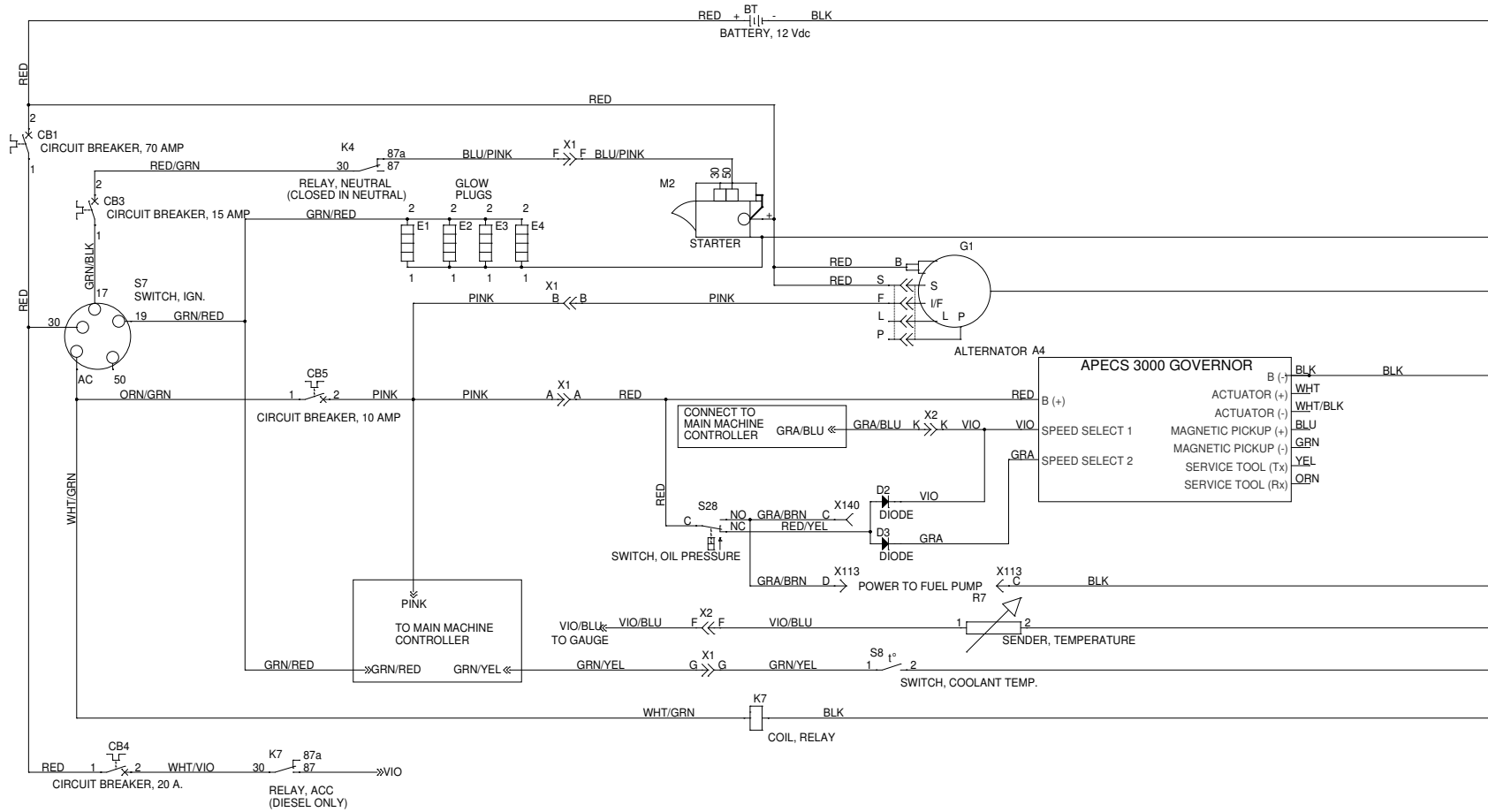

Wiring Diagram, Kubota Gasline Engine, p/n 56107658, Rev. A.

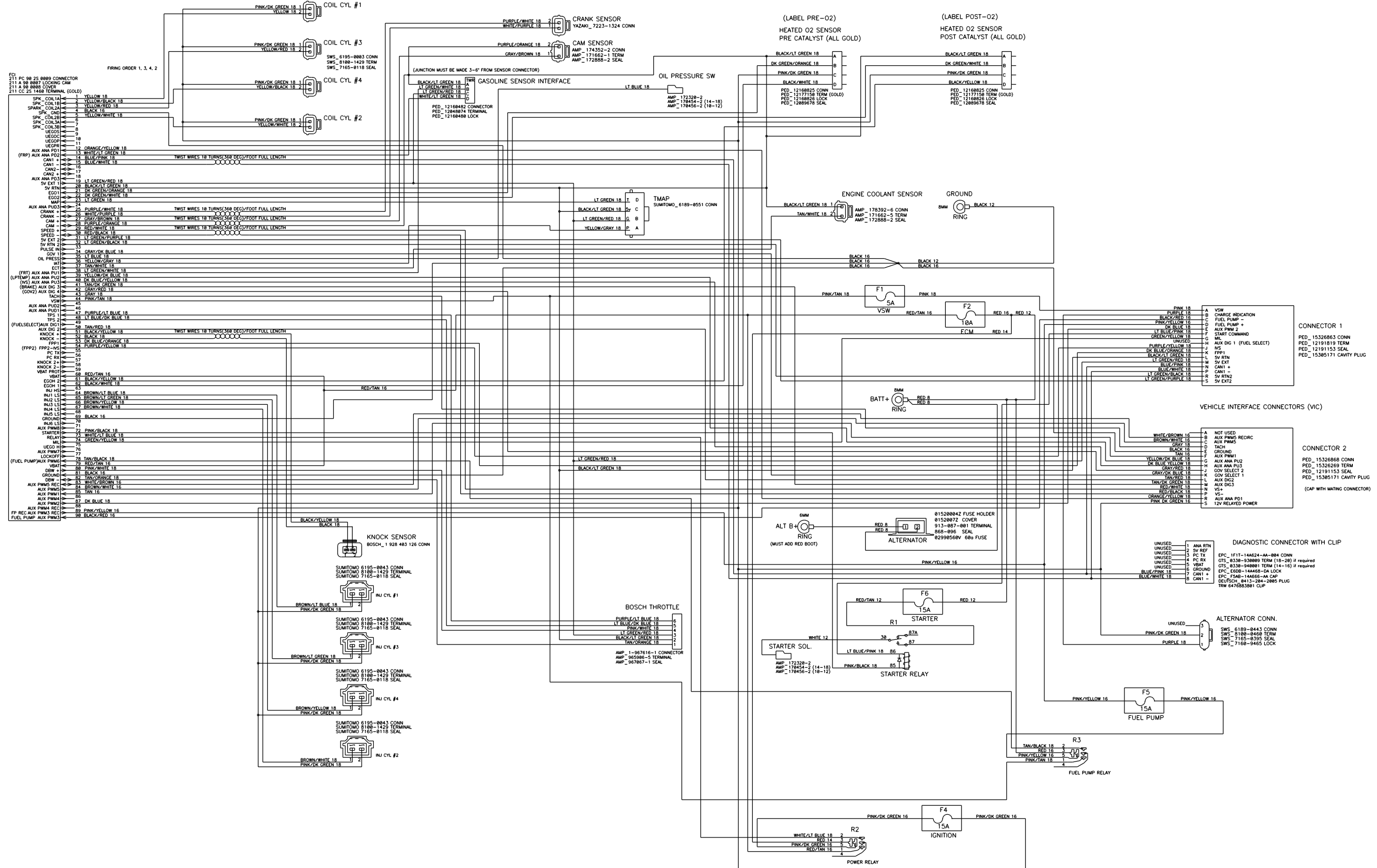

Wiring Diagram, Kubota LP Engine, p/n 56107659, Rev. A.

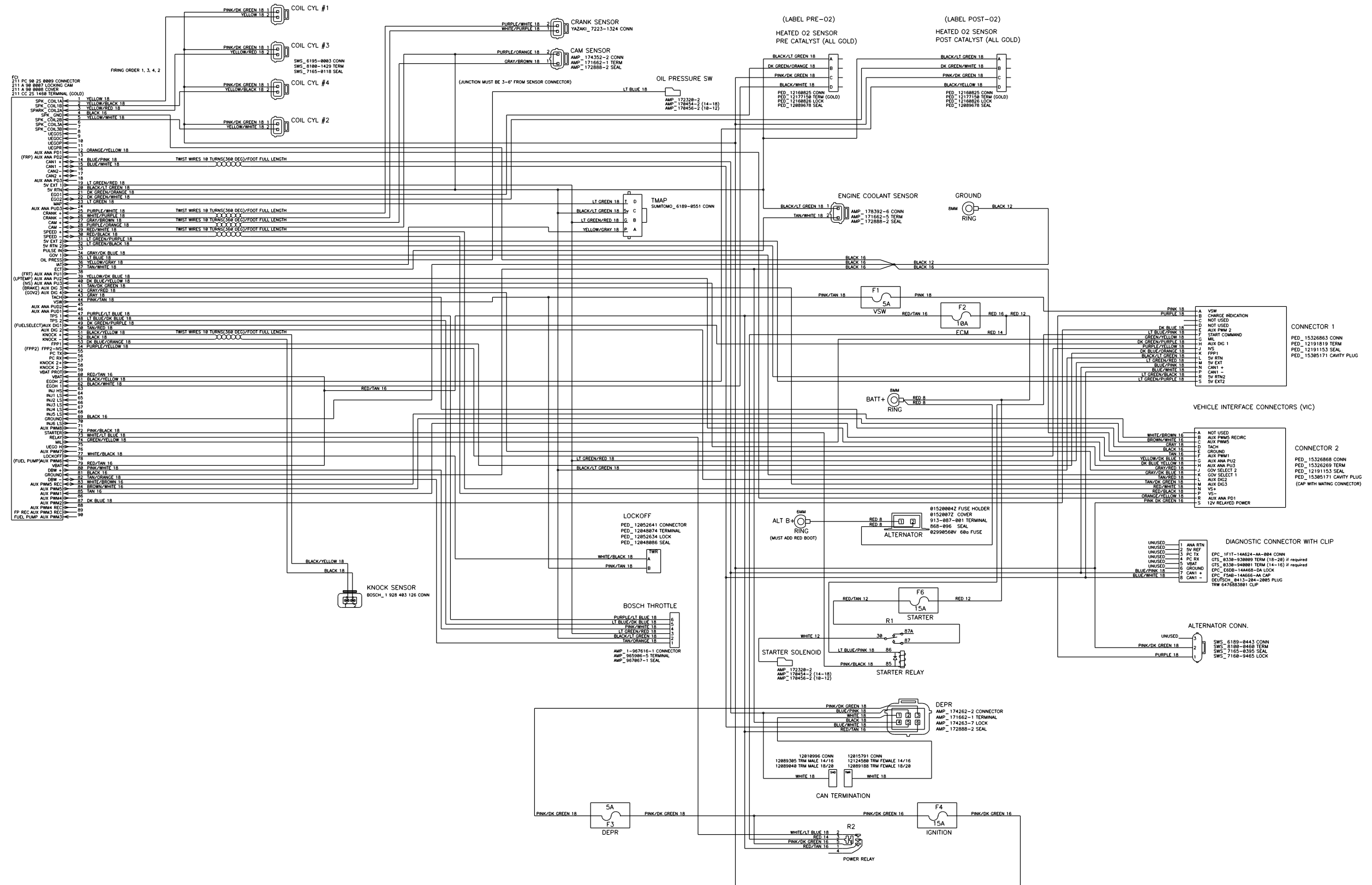

Wiring Harness Diagrams, p/n 56382531 Rev. D

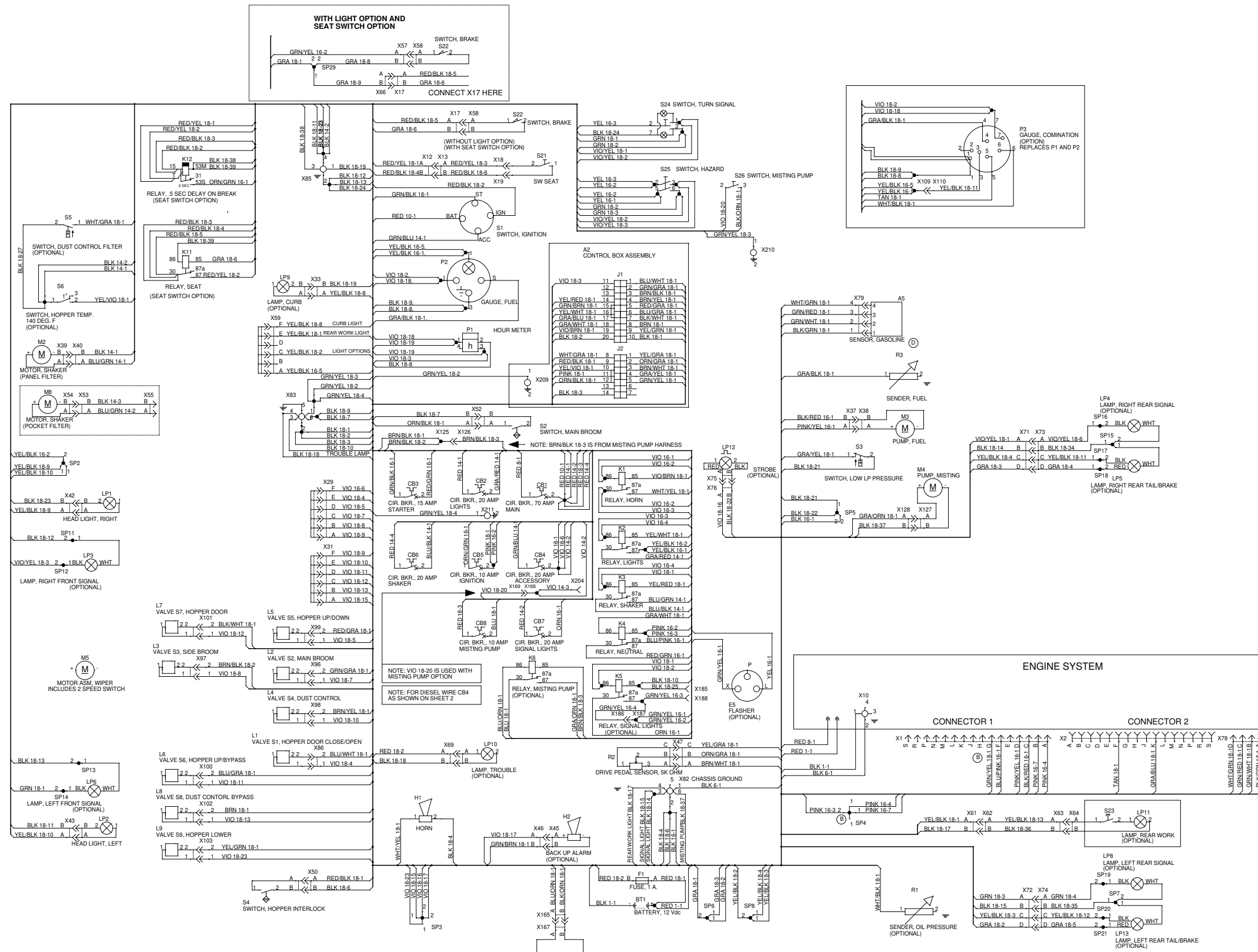

Notes: 1. Reference 56382530 Wiring Diagrams

Wiring Harness Diagrams, p/n 56382531 Rev. D, sheet 2 of 3

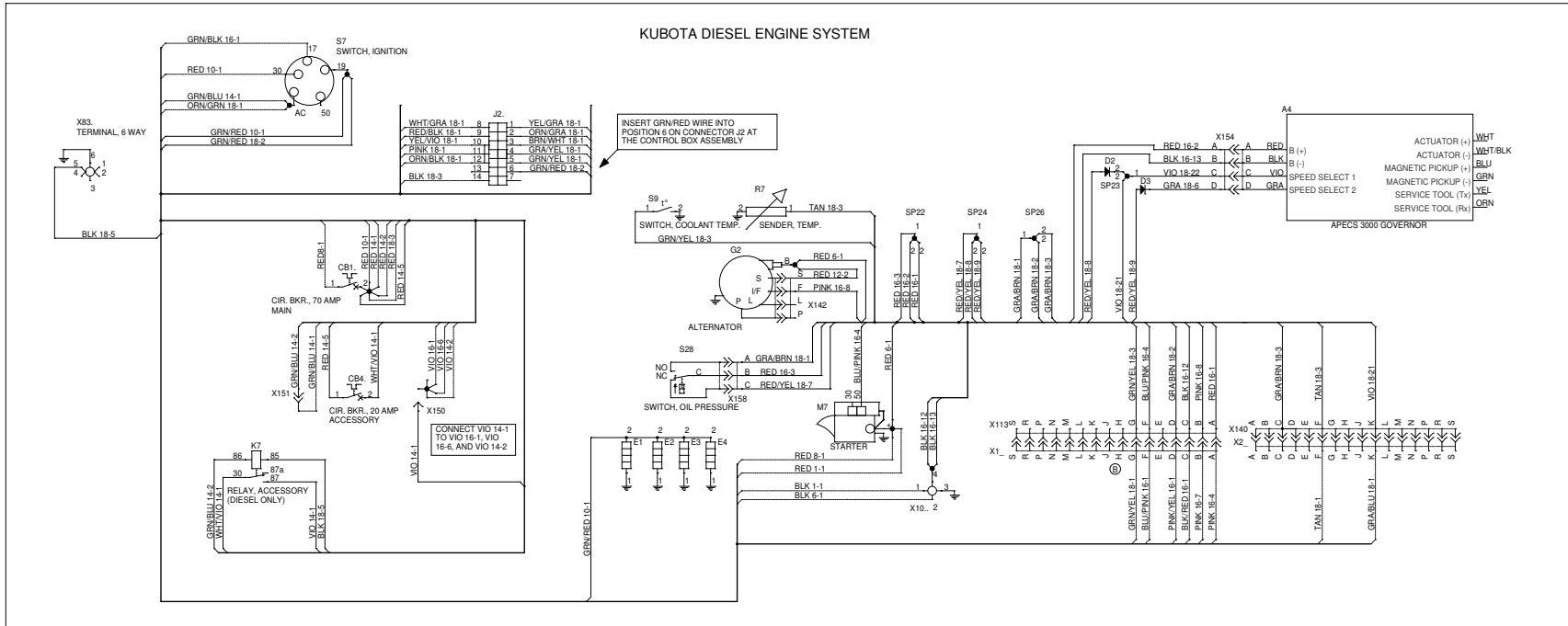

Engine System, Diesel

Functional Description

Overview

The diesel SW8000 machines use a Kubota V-1505-E3B four-cylinder diesel engine to power the two hydraulic pumps that run the machine drive wheel motor, main and side brooms, vacuum fan motor, side broom hydraulic cylinder, hopper lift cylinder, hopper door cylinder and the steering system.

Engine Description

The Kubota V1505 diesel is a four-cylinder, liquid cooled, naturally aspirated engine. A *Bosch* MD type mechanical injection pump fitted with an actuator that physically moves the fuel lever inside the pump. The injection pump controls the fuel quantity to maintain the selected RPM or shut the engine off.

Fuel is stored in a tank under the Operator's seat. The tank contains a fuel level sending unit. An electric pump supplies low pressure fuel to the diesel injector pump. There is a replaceable fuel filter cartridge between the fuel pump and the injector pump. The injector pump has a small "return" line that runs to the closest injector. The return circuit is carried from injector to injector where it exits the rear injector, and is connected to a hose that returns back to the fuel tank.

The engine uses glow plugs to aid in starting a cold engine.

The engine RPM is controlled with the *Woodward APECS 3000* Electronic Engine Speed Governing System based on requests from the main machine controller. The main machine controller sends signals to the *Woodward* Governing System controller to request one of two engine speeds based on Operator request.



Note: There is a "Dead Man" Lever on the side of the injector pump that can be used to shut the injection pump fuel down to shut off the engine manually.

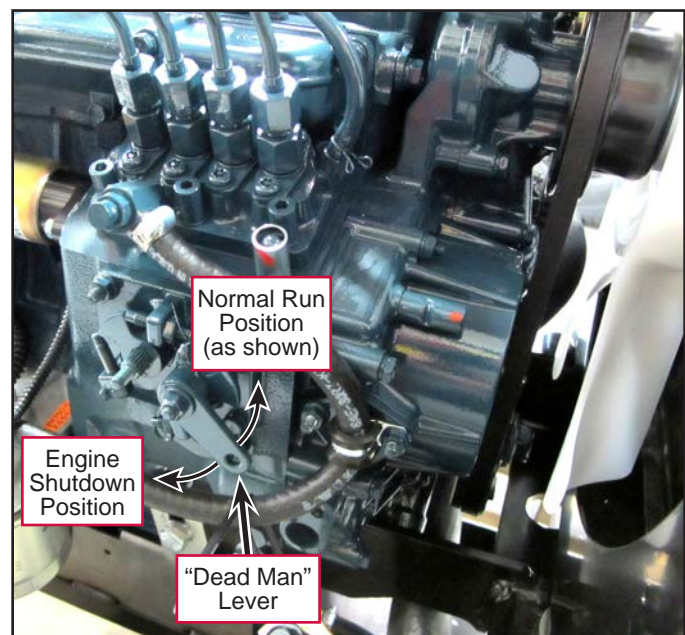

The cooling system consists of a standard radiator and belt driven fan. Note that the fan pushes air away from the engine and out through the radiator.

Manufacturers' Technical Literature

Also refer to the following manufacturer's technical literature when servicing or repairing the engine:

- *Kubota 05 Series Service Data Book 9Y110-00051.pdf*
- *Workshop Manual, Diesel Engine, 05 Series, WG1605 9Y111-06610.pdf*
- *Woodward Product Specification 03399, APECS™ 0175 Series Actuators*

Engine Starter Circuit

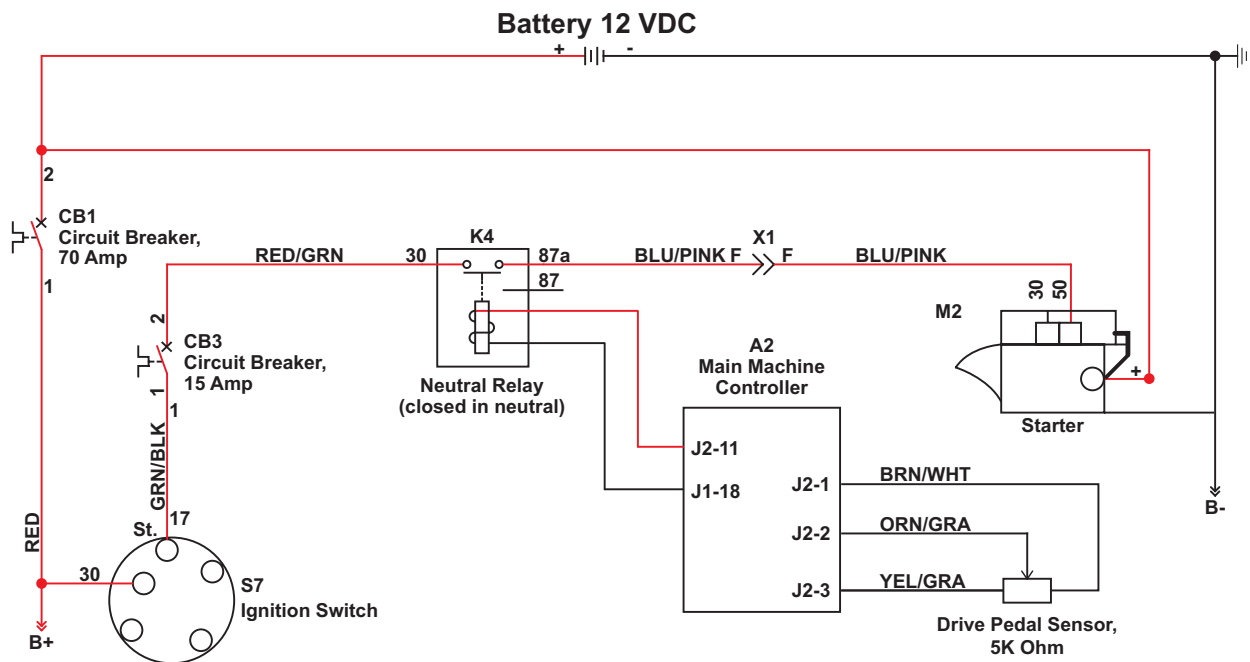

Starter Circuit Description

For the engine to start:

- The **Ignition Switch** must provide positive voltage to the contact side of the **Neutral Relay, K4**, and to the positive terminal on the **Starter**.
- The **A2 Main Machine Controller** must send power to the coil on the **Neutral Relay, K4**. In order to do this, the **A2 Main Machine Controller** must sense that the resistance through the **5K Ohm Drive Pedal Sensor** is within the programmed deadband range.
- The **Neutral Relay, K4**, must close to provide positive voltage to the **Starter**.

Engine Protection – Low Oil Pressure Shutdown

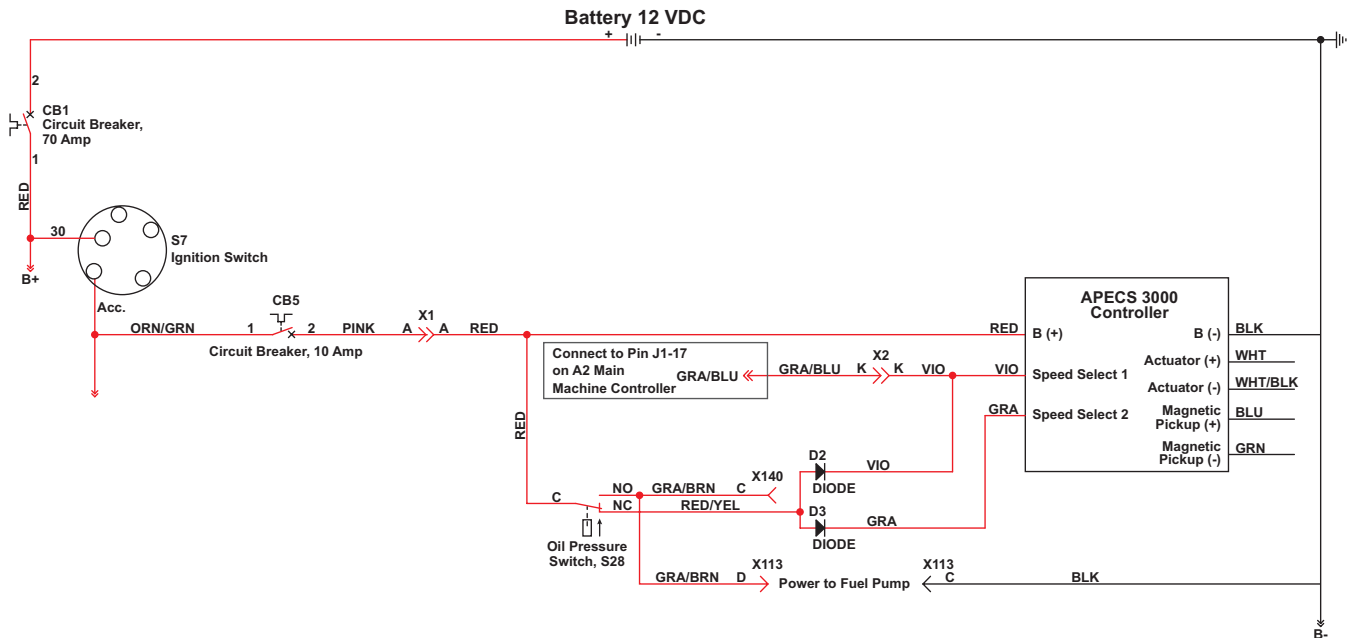

- The fuel pump electrical power comes from the **NO** contact of the **Oil Pressure Switch, S28**. When oil pressure builds, the **Oil Pressure Switch** connects **C** to the **NO** terminal to provide power to the fuel pump.
- If oil pressure is lost, the **Oil Pressure Switch** will connect **C** to the **NC** terminal. This takes power away from the fuel pump and gives 12V to both **Speed Select 1** and **Speed Select 2**, which is the “lost oil pressure” signal to the **APECS 3000 Controller**. When the **APECS 3000 Controller** sees this signal, it shuts down the engine by turning “off” the fuel actuator on the engine.

Engine Speed Control

The **APECS 3000 Controller** manages the engine RPM through the use of an electronic actuator connected to the fuel control lever inside the injector pump. The **Controller** monitors the actual engine RPM via a speed sensor connected to the **Magnetic Pickup (+)** and **(-)** terminals. The speed sensor reads the flywheel ring gear teeth and the **Controller** compares the actual engine speed to the desired speed setting. The **Controller** sends out a pulse-width-modulated signal to the actuator, which then moves the fuel control lever to regulate the engine speed. The **Controller** increases the current it sends through the actuator to increase the engine speed. The actuator is spring-loaded in the “no fuel” default position, and will shut off the fuel to the engine when there is no electrical current available from the **Controller**.

When the **A2 Main Machine Controller** receives an engine speed request from the engine speed switch on the control panel, it sends either +12V or 0V from pin J1-17 to the **Speed Select 1** terminal on the **Controller**. The **Controller** then sends the appropriate current from the **Actuator** terminals to the actuator to obtain the desired RPM corresponding to the engine speed requested.

The following table shows the inputs to the **Speed Select 1** and **2** terminals and the resulting action.

APECS 300 Controller Inputs		
Speed Select 1	Speed Select 2	Engine Condition
0v	0v	Idle
12v	0v	High Speed
0v	12v	(Not Used)
12v	12v	Low Oil Pressure Shutdown

Glow Plug Control

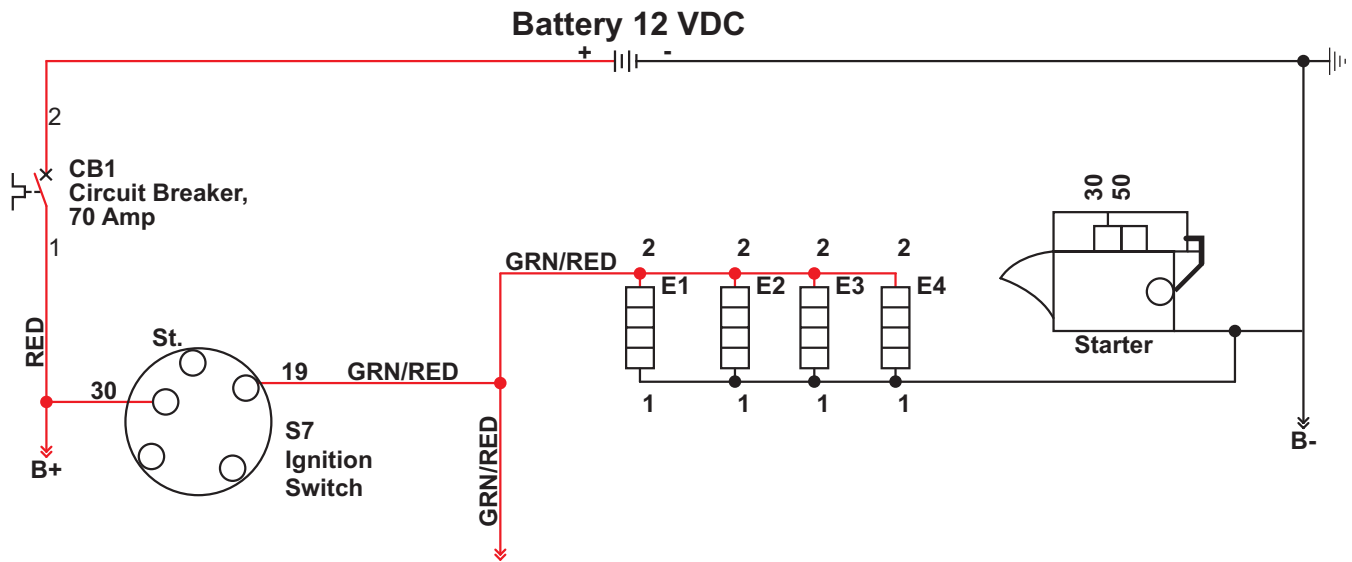

The engine is equipped with glow plugs to assist starting a cold engine. The **Battery** provides voltage to the **Glow Plugs** when the **Ignition Switch, S7**, is in the engine-run position.

The glow plugs have an internal resistive element that increases in resistance as it heats up. This protects the glow plug from overheating by reducing the current flow as it gets hot.

Note that you have to hold the key switch in the counterclockwise position to get power to the glow plugs. When the power to the glow plugs is switched on, the A2 Main Machine Controller will light the glow plug indicator on the control panel for six seconds.

Component Locations

The following components are included in this section:

- Coolant Temperature Switch
- Alternator
- Oil Pressure Switch
- Starter
- Air Cleaner
- Engine RPM Sensor
- Woodward APECS™ Controller
- Woodward APECS™ Actuator
- Fuel Filter

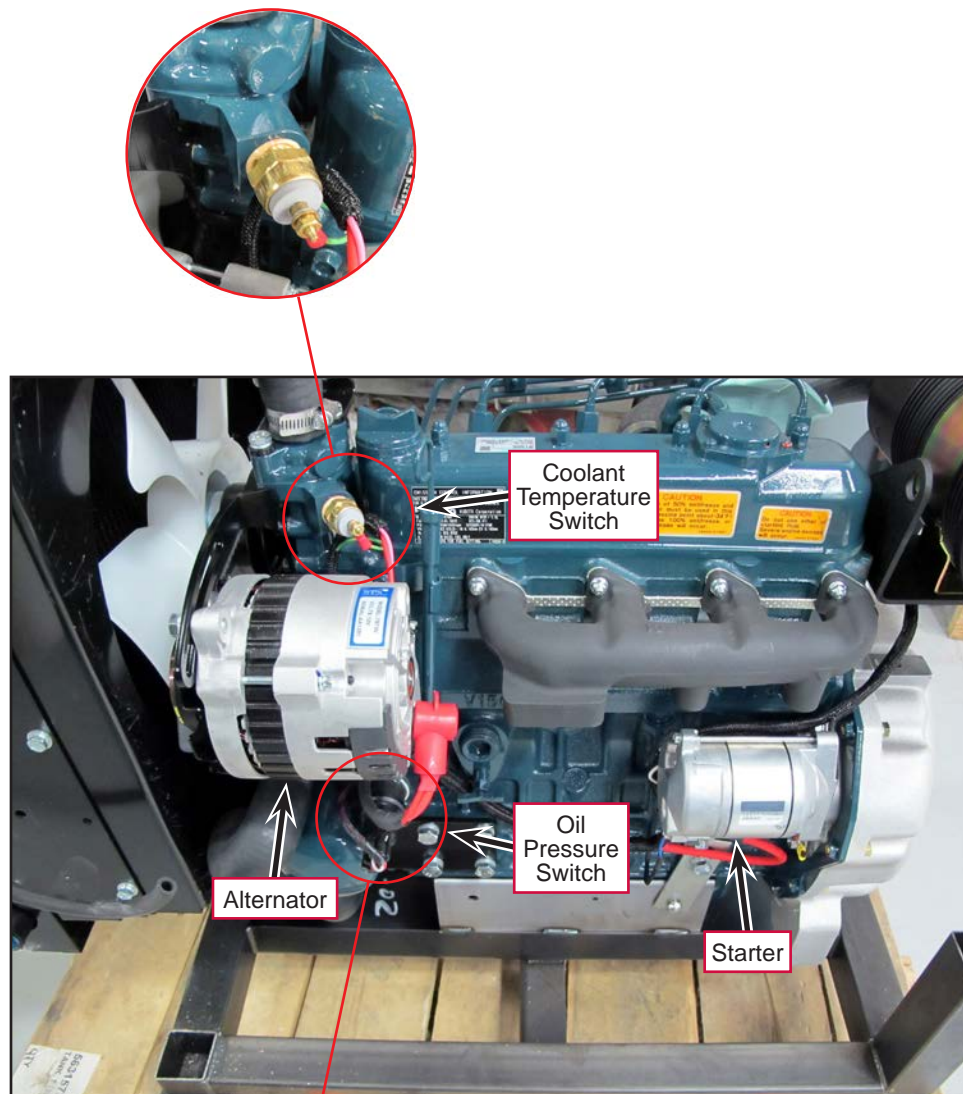

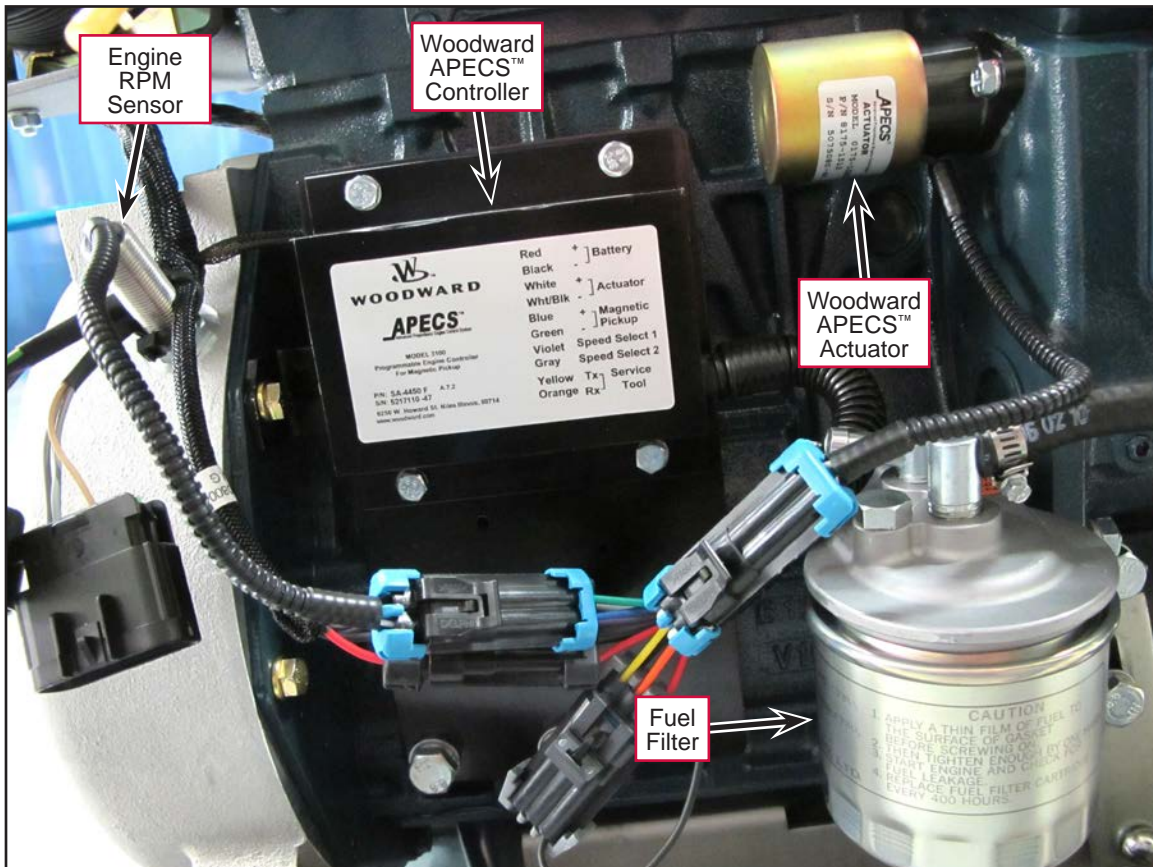

Maintenance and Adjustments



Warning! Before performing any machine maintenance or adjustments, make sure the parking brake is engaged, key switch is off and the key is removed from the machine.

Maintenance Schedule

Item	Service Interval											
	Every 50 hrs.	Every 75 hrs	Every 100 hrs	Every 150 hrs	Every 200 hrs	Every 300 hrs	Every 400 hrs	Every 500 hrs	Every 800 hrs	Every 1500 hrs	Every Year	Every Two Years
Check fuel pipes and clamps	X											
* Change engine oil					X							
* Change oil filter cartridge					X							
Clean air filter element			X									
Clean fuel filter element			X									
Check fan belt tension and for damage			X									
Check water pipes and clamps					X							
Change fuel filter cartridge							X					
Clear radiator interior								X				
Change radiator coolant												X
** Check injection nozzle										X		
Change air filter element											X	
Check valve clearance									X			
Change water pipes and clamps												X
Change fuel pipes and clamps												X

* Change the engine oil and filter cartridge after the first 50 hours of operation.

** Maintenance intervals per EPA instructions

Engine Oil

Check the engine oil level when the machine is parked on a level surface and the engine is cool. Change the engine oil and oil filter after the first 50 hours of operation, then every 200 service hours after that. Use CF, CF-4 or CG-4 oil meeting API specifications and suited temperatures.

- * **Important:** Refer to the **Diesel Lubricating Oil Note** below for further diesel oil recommendations. Refer to the engine manufacturer's service manuals for oil capacities and additional engine specifications. Replace the oil filter with every oil change.

Temperature Range	Oil Weight
Above 77 °F (25 °C)	SAE 30 or 10W-30
32 °F to 77 °F (0 °C to 25 °C)	SAE 20 or 10W-30
Below 32 °F (0 °C)	SAE 10W or 10W-30

* Diesel Lubricating Oil Note:

With the emission control now in effect, the CF-4 and CG-4 lubricating oils have been developed for use with a low-sulfur fuel used in on-road vehicle engines. When an off-road vehicle engine runs on a high-sulfur fuel, it is advisable to employ the CF, CD or CE lubricating oil with a high total base number. If the CF-4 or CG-4 lubricating oil is used with a high-sulfur fuel, change the lubricating oil at shorter intervals.

Lubricating Oil class \ Fuel	Low sulfur (0.5 % ≥)	High sulfur	Remarks
CF	O	O	Refer to Kubota Diesel Engine Workshop Manual
CF-4	O	X	
CG-4	O	X	

O = Recommended X = Not Recommended

Engine Coolant

Checking Engine Coolant



Caution! Do not remove the radiator cap when the engine is hot.

To check the engine coolant level, open the engine cover and observe the coolant level in the coolant overflow tank. If the level is low, add a 50/50 mix of water and the recommended type antifreeze. Clean the radiator and oil cooler exteriors every 150 hours by washing with **low-pressure** water or using compressed air. **High-pressure water will damage the radiator.**

Replacing Engine Coolant

One possible cause of engine overheating is trapped air in the cooling system. It's recommended that you use a Cooling System Tool when changing the engine coolant. The Cooling System Tool pulls a vacuum on the cooling system prior to filling to prevent air from being trapped in the cooling system.

Note that there are several types of Cooling System Tools. The following instructions describe how to use a typical type of tool. Refer to the operating instructions included with your particular tool if different than the example shown here.

1. Connect a **Compressed Air Supply Line** to the fitting on the Cooling System Tool.
2. Connect the **Coolant Supply Line** to the Cooling System Tool. Make sure the **Coolant Valve** is closed.
3. Insert and hold the Cooling System Tool onto the radiator filler neck, then press the **Air Switch**. The compressed air travelling through the **Venturi Tube Assembly** will pull a vacuum on the cooling system to remove air from the system.
4. Once the vacuum reading on the **Gauge** reaches approximately 25 on the green scale, release the **Air Switch**. Note that this also a good opportunity to check for cooling system leaks,
5. Continue to hold the Cooling System Tool onto the radiator filler neck and open the **Coolant Valve** to allow coolant to flow into the radiator.
6. Once the pressure on the **Gauge** reaches approximately 5 on the red scale and the radiator is almost full, shut off the **Coolant Valve** and remove the Cooling System Tool from the radiator filler neck.
7. Top off the radiator and overflow tank as necessary.

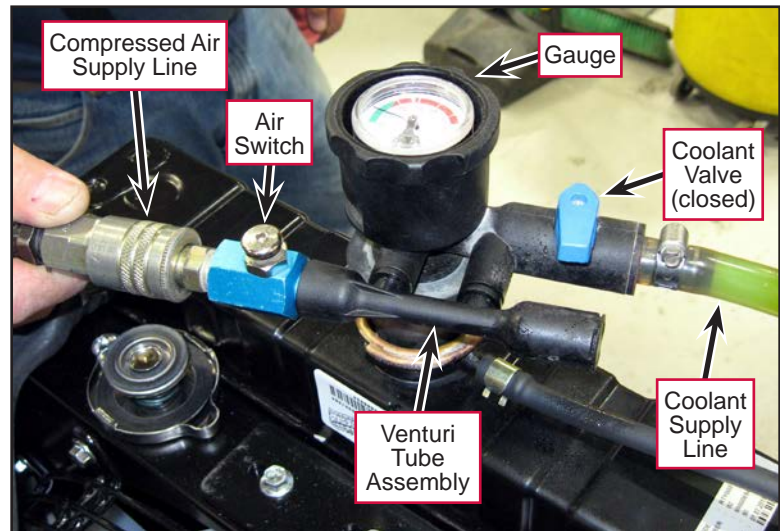

Removing the Air from the Cooling System with Cooling System Tool

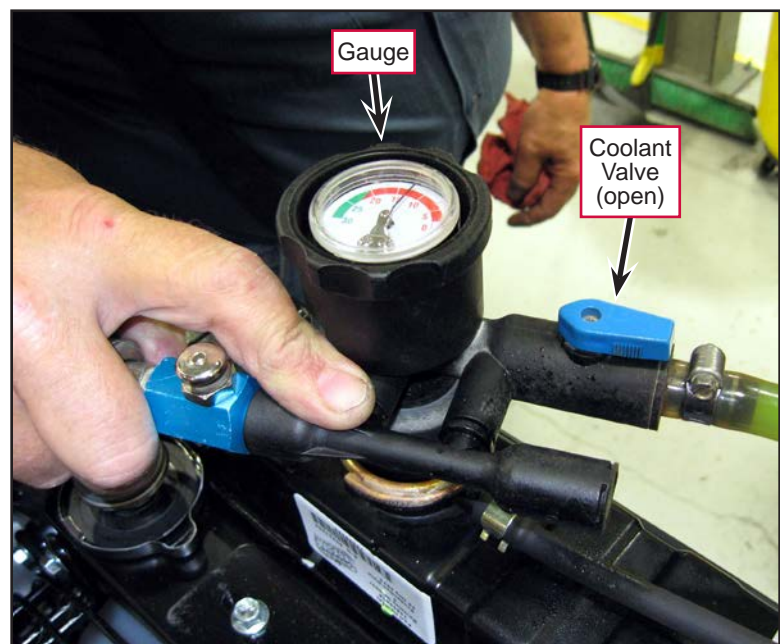

Filling Cooling System with Coolant

Engine Air Filter Maintenance



Caution! When servicing the engine air filter elements, use extreme care to prevent loose dust from entering the engine. Dust can severely damage the engine.

The engine air filter contains a primary (outer) and a safety (inner) filter element. The primary element can be cleaned twice before being replaced.

The inner safety element (blue) should be replaced every third time that the primary filter element is replaced. Never attempt to clean the inner safety element.

To clean the primary filter element:

1. Unlatch the two **Clips** at the end of the **Air Filter** and remove the **End Housing**.
2. Pull the primary element out.
3. Clean the element with compressed air (maximum pressure 100 psi) or wash it with water (maximum pressure 40 psi). **Do not** put the element back into the canister until it is completely dry.
4. Reinstall the inner safety element and primary filter element.
5. Reinstall the **End Housing** and latch the two **Clips**.

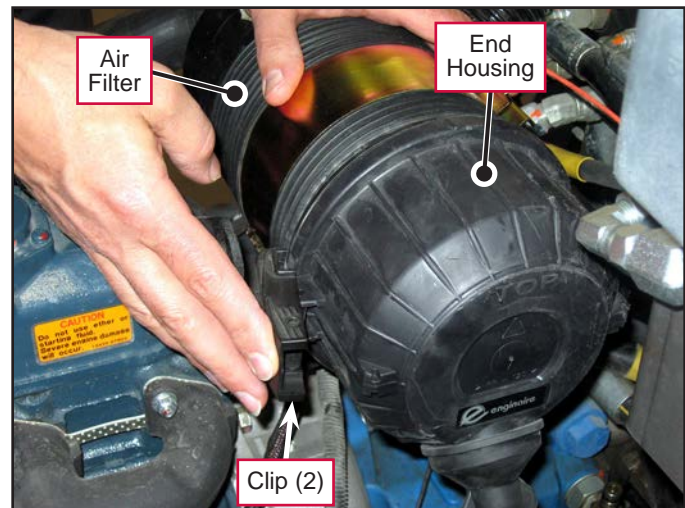

Replacing the Fuel Filter



Warning! Replacing the fuel filter can result in diesel fuel being spilled on the machine and surrounding areas. This can present a potential fire hazard that can result in serious personal injury or death.

- Do not replace the fuel filter on a hot engine as fuel spilled onto a hot exhaust manifold can catch fire.
- Replace the fuel filter in a well-ventilated area and observe all applicable safety precautions.
- Always wear the recommended personal protective equipment (PPE), including eye protection.

1. Place a pan or other suitable receptacle underneath the fuel filter to catch any spilled fuel.

2. Unscrew the **Fuel Filter** from the **Fuel Filter Housing**.
3. Pre-fill the new **Fuel Filter** with clean diesel fuel to minimize the amount of air that will need to be bled out of the fuel system.
4. Screw the new **Fuel Filter** onto the **Fuel Filter Housing**.
5. Bleed the remaining air out of the **Fuel Filter**. (Refer to the **Bleeding the Fuel System** subsection below.)

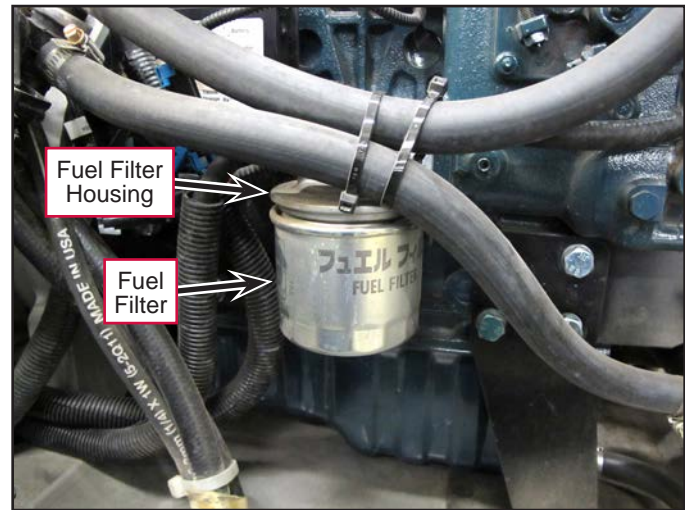

Bleeding the Fuel System

The electric fuel pump on the fuel tank pumps fuel to the fuel filter. The fuel flows through the filter to the injector pump on the engine. The injector pump pumps fuel under high pressure to the injectors.

You'll need to bleed the fuel system whenever the fuel filter element is removed/replaced, or if the machine runs out of fuel.



Warning! *Bleeding the fuel system can result in diesel fuel being spilled on the machine and surrounding areas. This can present a potential fire hazard that can result in serious personal injury or death.*

- *Do not bleed the fuel system on a hot engine as fuel spilled onto a hot exhaust manifold can catch fire.*
- *Bleed the fuel system in a well-ventilated area and observe all applicable safety precautions.*
- *Always wear the recommended personal protective equipment (PPE), including eye protection.*

1. Make sure the fuel tank is not empty.
2. Connect switched jumper wires from the battery to the electric fuel pump so you can run the fuel pump with the ignition switch off.



Service Note: *If you've removed or replaced the fuel filter element, fill the filter canister with fuel before you bleed the system. This will minimize the amount of air remaining in the filter.*

3. Turn on the fuel pump.

4. Slightly loosen the **Bleed Screw** on top of the **Fuel Filter** to remove the air from the fuel line and **Fuel Filter**.
5. When no more bubbles can be seen at the **Fuel Filter Bleed Screw** and the fuel is running clear, tighten the **Bleed Screw**.
6. Repeat steps 4 and 5 above as needed to remove all of the air from the fuel line and **Fuel Filter**. Note that you may need to do this four or five times.

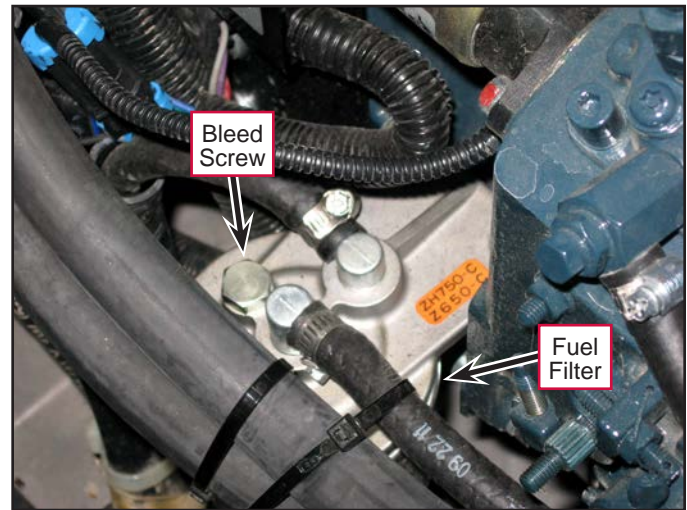

7. Use a wrench to hold the **Injector Pump** base stationary, then slightly loosen the **Bleed Screw** on top of the **Injector Pump** to remove the air from the **Injector Pump** fuel line.
8. When no more bubbles can be seen at the **Bleed Screw** and the fuel is running clear, tighten the **Bleed Screw**.

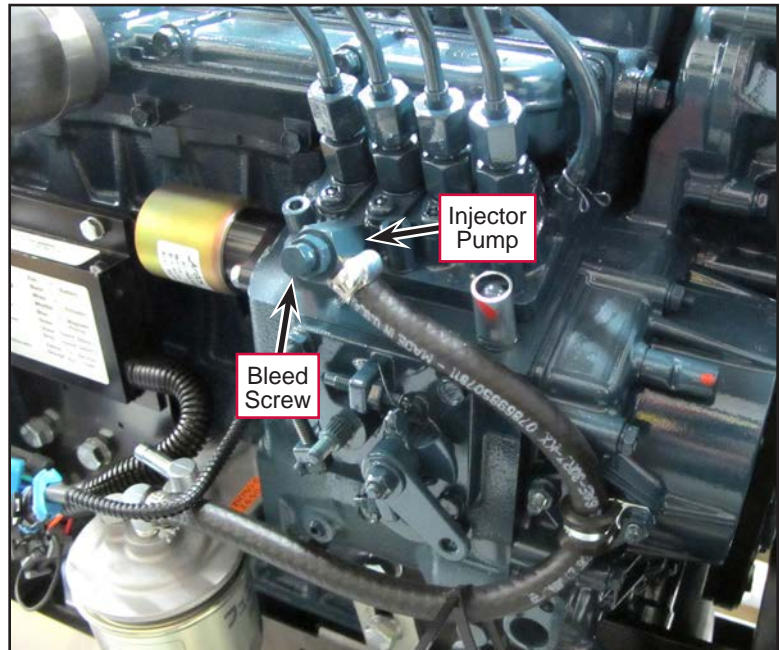



Service Note: Normally steps 9 through 17 below are not required to bleed the fuel system. If you do need to perform these steps to bleed the fuel system at the injector pump fittings and injector fittings, make sure to follow the safety warning information below.



Warning! If you need to bleed the fuel system at the injector pump fittings or injector fittings as outlined in steps 9 through 17 below, make sure to wear protective gloves to protect your hands from the high-pressure diesel fuel present at these fittings. This high-pressure fuel is capable of piercing the skin and injecting diesel fuel into the skin, which can result in severe personal injury.

9. If necessary, slightly loosen one of the four **Injector Pump Fittings** on the top of the injector pump.
10. Crank the engine to bleed any air from the **Injector Pump Fitting**.
11. When no more bubbles can be seen at the **Injector Pump Fitting** and the fuel is running clear, tighten the **Injector Pump Fitting**.
12. Repeat steps 9 through 11 above for the other three **Injector Pump Fittings**.

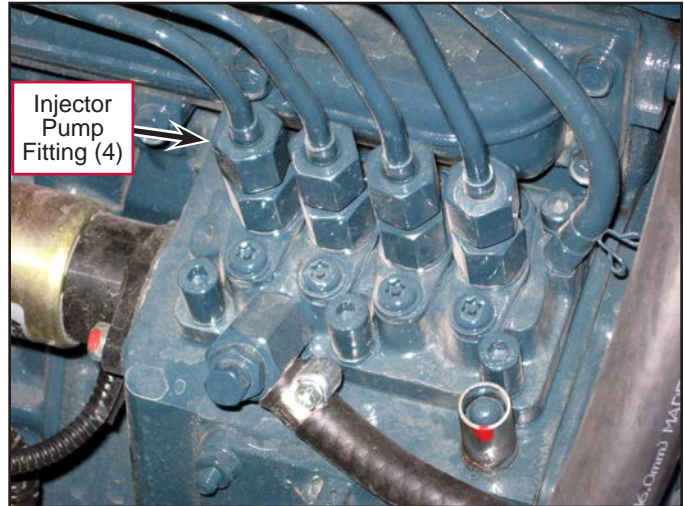

Service Note: If you need to bleed the fuel system at the injector fittings as described below, it's recommended that you start with the fitting on the shortest line and finish with the fitting on the longest line.

13. If necessary, slightly loosen one of the four **Injector Fittings**.
14. Crank the engine to bleed any air from the **Injector Fitting**.
15. When the injection pulses can be seen at the **Injector Fitting** and the fuel is running clear, tighten the **Injector Fitting**.
16. Repeat steps 13 through 15 above for the other three **Injector Fittings**.
17. Make sure the check valve is oriented so that fuel can only flow from the rear injector to the fuel tank,

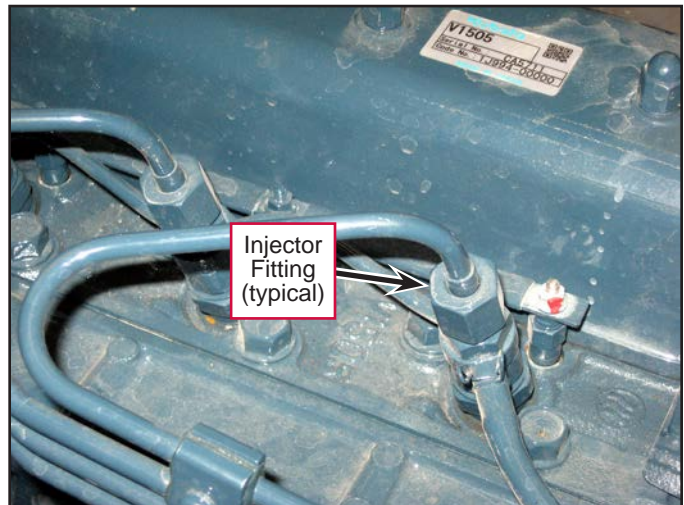

Troubleshooting



Note: Also refer to the Workshop Manual, Diesel Engine, 05 Series, WG1605 9Y111-06610.pdf for additional troubleshooting information and procedures.

General Troubleshooting

Problem	Cause	Correction
The engine will not crank; the starter does not engage.	The drive pedal is not in neutral.	Make sure the drive pedal is in its neutral position.
	The battery charge level is low.	1. Check the battery voltage and charge as necessary. 2. If the engine still won't crank, load-test the battery. Replace the battery if necessary.
	No power to the starter.	<ul style="list-style-type: none"> • Check circuit breaker CB1 and reset if necessary. • Check circuit breaker CB3 and reset if necessary. • Make sure there is continuity through the Neutral Relay K4 terminals 30 and 87a with the drive pedal in neutral. <ol style="list-style-type: none"> 1. Reset the foot pedal deadband position if necessary. (Refer to the Control System/Main Machine Controller Programming/Hydrostatic Neutral Position and Dead-band section.) 2. Check the relay coil resistance. If not 85 ± 5 ohms, replace the relay. <ul style="list-style-type: none"> • Check the wiring to the starter and repair as necessary.
The engine cranks but will not start.	No power to the glow plugs.	<ul style="list-style-type: none"> • Check wiring from the ignition switch to the glow plugs and repair as necessary. • Check the ground connection to the glow plugs and repair as necessary.
	No output from the APECS 3000 Controller to the actuator.	<ul style="list-style-type: none"> • Check wiring to the Controller and repair as necessary. • Check the wiring from the actuator terminals on the Controller to the actuator and repair as necessary.
	The APECS 3000 Controller is not operating correctly.	<ul style="list-style-type: none"> • Check the APECS 3000 Controller fault codes and take the recommended corrective actions. (Refer to the APECS 3000 Controller Fault Codes subsection.)
The engine stops running, service indicator light is on.	The coolant temperature is too high.	Refer to the Engine Overheating Problems section below.
	The oil pressure has dropped below the minimum acceptable pressure.	Refer to the Loss of Oil Pressure Protection section below.
Engine will not run at operating speed.	There is no +12V signal from pin J1-17 on the A2 Main Machine Controller to the Speed Select 1 terminal on the APECS 3000 Controller.	<ul style="list-style-type: none"> • Check the wiring from pin J1-17 to the Speed Select 1 terminal on the APECS 3000 Controller (GRA/BLU wire). • If this doesn't correct the problem, there may be a problem with the A2 Main Machine Controller or APECS 3000 Controller.

Engine Overheating Problems

When the Coolant Temperature Switch S8 senses that the coolant temperature is too high, it grounds out the wire to the MIL INPUT J2-5 input on the A2 Main Machine Controller. The A2 Main Machine Controller then lights the Engine Service Indicator light on the control panel.

Use the checklist below as a guide to thoroughly check the engine cooling system.

- Check the coolant level in the overflow tank and radiator.
- Inspect and clean the radiator and hydraulic oil cooler.
- Check for correct operation of the belt-driven engine cooling fan (slippage).
- Check to see that the engine thermostat opens.
- Check for correct water pump operation.
- Check the engine crankcase oil level.
- Check for air trapped in the cooling system. (Refer to the [Engine Coolant/Replacing Engine Coolant](#) section.)
- Check the coolant temperature switch for correct function as replace if necessary.

Loss of Oil Pressure

Check for possible causes for low oil pressure such as:

- Engine crankcase level is low.
- Incorrect oil viscosity.
- Fault in the oil pressure switch S28.
- Excessive engine wear or defective internal oil pump (relief valve)

APECS 3000 Controller Fault Codes

The *Woodward* APECS 3000 Controller is capable of identifying some fault conditions and displaying a fault code. A flashing LED displays the fault conditions. When power is first applied to the Controller, the LED will flash just once for one second to indicate that the LED is operational. If there is more than one fault, the LED will flash them all. If there are no faults the LED will flash once every reset, and from then on indicate the detection of engine speed. The controller will attempt to shut the engine down for all faults and will not permit starting after reset with fault 1, 5 and 6.

Flash Code	Fault	Correction
1	APECS unit not calibrated.	Calibrate the unit.
2	Excessive engine speed.	Check parameter settings, wiring, case ground, linkage and speed sensor.
3	Unusually low engine speed.	Check parameter settings, linkage, load and engine capacity.
4	Protection input shuts down engine.	Check parameter settings and probable cause for fault.
5	Factory settings lost.	Download calibration file and recycle power or consult factory.
6	APECS unit failed.	Check wiring, shielding, and recycle power. Consult factory.

Compression Test



Note: The photos shown in this section are from a similar three-cylinder diesel.

1. Begin with a fully-charged battery.
2. Remove the air cleaner assembly.
3. Cover the air inlet opening to prevent foreign objects from falling into the engine.
4. Remove the glow plug **Electrical Connector Nuts** and **Connector "Rail"**.

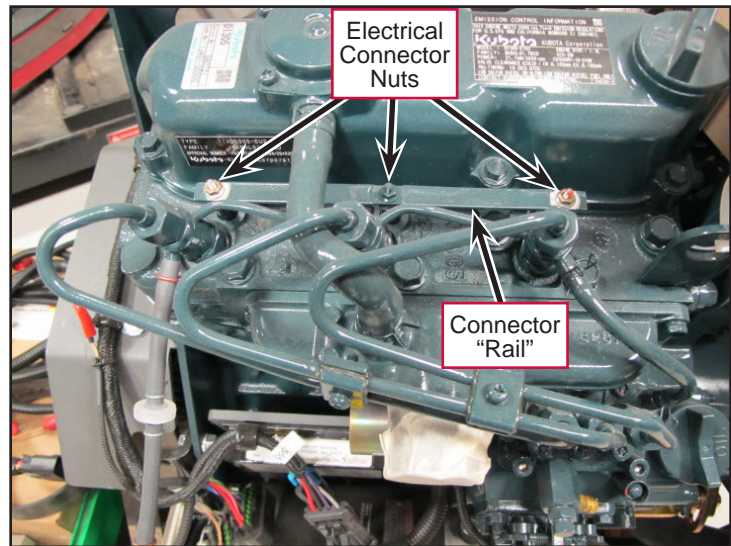

5. Insulate the **Electric Terminal** that feeds the rail to prevent it from shorting to ground.
6. Clean the area around the glow plugs to prevent any debris from falling into the engine cylinders when they are removed.
7. Remove the glow plugs.

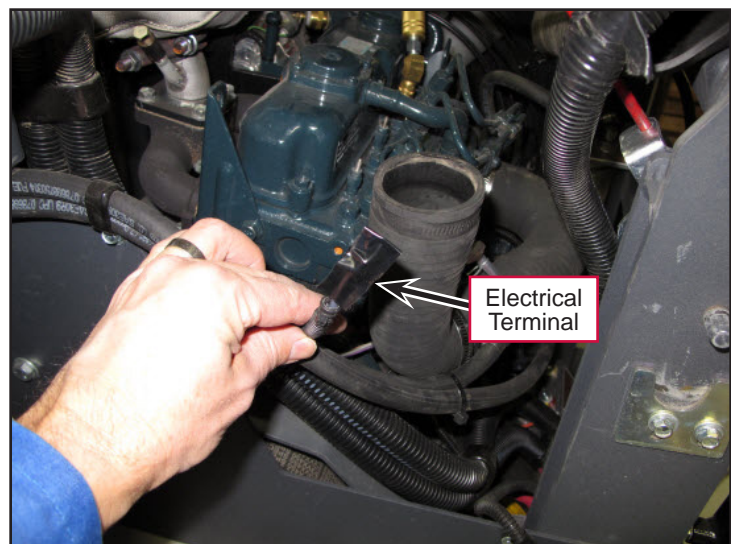

- To test the compression of one of the cylinders, screw in an appropriate adapter into the glow plug threads in the cylinder head and attach a suitable compression gauge. Pictured are Snap-On® Diesel Compression gauge **EEP500** used with compression test adapter fitting **TU-15-35** and coupler **M3569**.

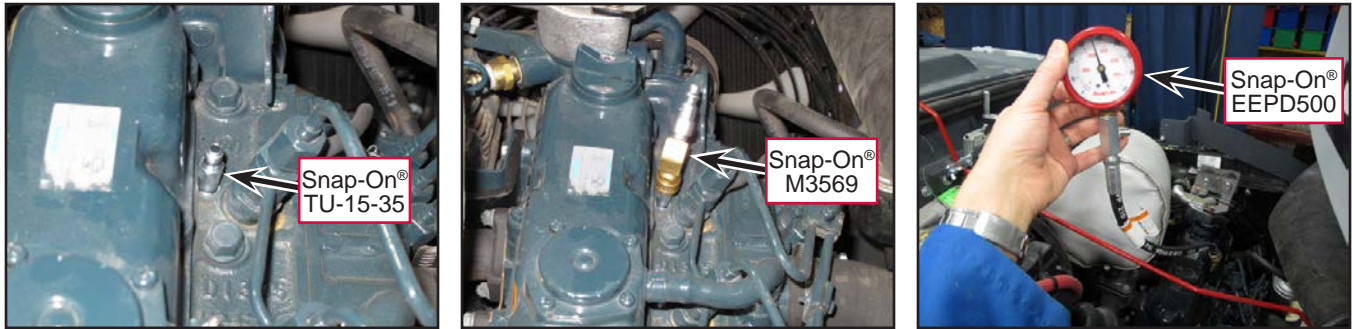

- Disconnect the **Injector Pump Actuator Connector** to prevent the engine from starting.
- Remove any cover over the air inlet but be very careful not to allow anything to get “sucked in” during the test.
- Crank the engine over until the compression gauge stops climbing. Record the reading. The cranking compression specifications are shown in the following table:

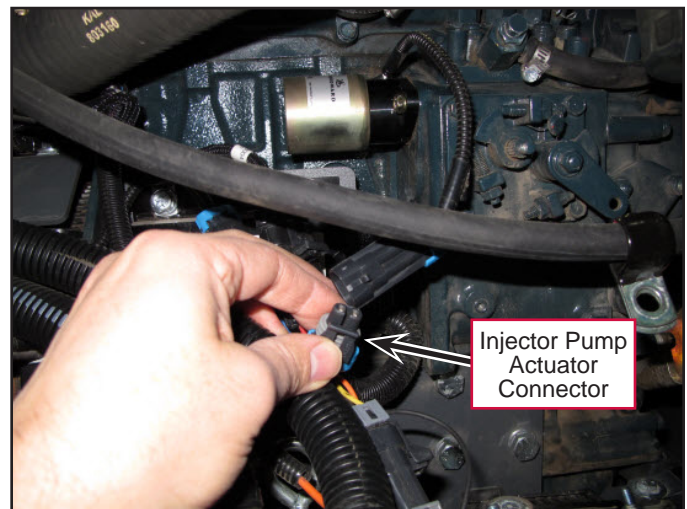

Factory Specification	3.14 to 3.53 MPa
	32.0 to 36.0 kgf/cm2
	456 to 512 psi
Allowable Limit	2.26 MPa
	23.0 kgf/cm2
	327 psi

The allowable difference among cylinders is 10% or less.

- Repeat for the other cylinders.
- Reassemble in reverse order.

Specifications

Kubota V-1505 -E3B Diesel		
Engine Type	Water cooled, four-cylinder, four-stroke diesel engine	
Displacement	91.41 cubic inches [1.498 L]	
Bore and Stroke	3.07" x 3.09" [78 mm x 78.4 mm]	
Compression Ratio	22:1	
Engine Firing Order	1-3-4-2	
Rotation	Counterclockwise (as viewed from the flywheel end)	
Cranking Compression	Factory Specification	3.14 to 3.53 MPa
		32.0 to 36.0 kgf/cm ²
		456 to 512 psi
	Allowable Limit	2.26 MPa
		23.0 kgf/cm ²
		327 psi
Fuel System	Fuel Injector Pump	Bosch MD Type Mini Pump
	Fuel Filter	Cartridge Type
	Fuel Pump Pressure	3-5 psi
	Fuel Pump Volume Capacity	30 GPM [113.6 LPM]
	Fuel Injection Nozzle	Mini Nozzle (DNOPD)
	Injection Pressure	140 kgf/cm ²
		1,991 psi
13.73 MPa		
Lubrication System	Type	Forced Lubrication by Pump
	Engine Oil	API Service Class CF Recommended
	Engine Oil Capacity	6.34 US qts.[6 L]
	Oil Filter	Full Flow Paper Filter (cartridge type)
Cooling System Type	Pressurized Radiator, Forced Circulation with Water Pump	

Kubota V-1505 -E3B Diesel		
Electrical System	Engine RPM Sensor	Resistance – 2.1K ohms near room temperature
		Output while cranking (unplugged) – 3.6 to 3.9 VAC
		Output at idle (connected) – 14.0 VAC
	Actuator	Resistance – 3.3 Ohms near room temperature
		Voltage supply from APECS controller when cranking – approximately 8.0 VDC
	Starter	160-190 Amps cranking

Special Tools

Cooling System Tool	
<p>Diesel Compression Gauge There are many brands of compression gauges available. Shown is a Snap-On® EEPD500 Gauge kit</p>	
<p>Compression Gauge Fitting for Glow Plug threads Shown is the Snap-On® TU-15-35; Threads - M8 X 1.0</p>	

Gauge Coupler

If using the Snap-On® diesel compression EEPD500 Gauge kit and Snap-On® TU-15-35 glow plug thread fitting, a coupler must be used to join the fitting to the gauge hose. Shown are Snap-On® couplers M3569 and M3570.



Engine System, Gasoline/LPG

Functional Description

Overview

The gasoline (petrol) and LPG SW8000 machines use a four-cylinder 1.6L Kubota engine to power the two hydraulic pumps that run the machine drive wheel, steering system, side and main broom hydraulic motors, dust control hydraulic motor, and the hopper lift and door cylinders.



Note: Also refer to the following manufacturer's technical literature:

- *Operator's Manual WG1605 EG523-89162ENG.pdf*
- *Engine Specifications WG1605 9Y110-01770.pdf*
- *Workshop Manual WG1605 9Y111-06610.pdf*
- *Diagnosis Manual ECM System WG1605 9Y110-01760.pdf*

Engine Description

The Kubota WG1605-G-E3 (gasoline) and WG1605-L-E3 (LPG) are four-cylinder, liquid cooled, naturally aspirated engines.

Kubota 1.6L Gasoline Fuel System Description

This engine uses an electric fuel pump to pump gasoline through the gas filter to the Gasoline Fuel Pressure Manifold assembly. The Gasoline Fuel Pressure Manifold assembly controls the delivery of gasoline to the gasoline injector rail assembly. Each cylinder has a fuel rail, mounted with injectors. An Electronic Throttle Body (ETB) is used to control engine speed.

The Gasoline Fuel Pressure Manifold is equipped with a sensor that sends fuel temperature and pressure data to the Engine Control Module (ECM). The ECM uses this information to calculate the precise amount of gasoline to be injected to the engine during operation. This eliminates the need for a separate return line from the fuel rail assembly.

Kubota 1.6L LPG Fuel System Description

The fuel system on LPG engines includes an LPG Fuel Lock-off device, Dual Stage Regulator (DSR), Direct Electronic Pressure Regulator (DEPR), Mixer Assembly and Electronic Throttle Body (ETB).

An LPG Fuel Lock-off device, consisting of a 12 volt solenoid and a normally-closed valve, opens during cranking and engine run cycles. The ECM controls the voltage to the LPG Fuel Lock-off device.

The DSR is a two-stage regulator that is a combination vaporizer, pressure regulating device. The DSR normally closed when the engine is not running. When the engine is cranking or running, a partial vacuum is created in the fuel line which connects the regulator to the DEPR and Mixer Assembly. This partial vacuum opens the second stage regulator, permitting fuel to flow to the DEPR and Mixer Assembly.

The DEPR controls the fuel flow, and provides the correct air/fuel mixture to maintain performance and emissions control. The DEPR uses an internal computer, and fuel pressure and temperature sensors to provide input to the ECM for fuel calculation, fault detection and diagnostics.

The Mixer Assembly is a self-contained air/fuel metering device that utilizes a relatively constant pressure drop to draw fuel into the mixer from cranking to full load. The Mixer Assembly is mounted in the air stream, ahead of the ETB.

The ETB uses an electric motor, connected to the throttle shaft, to increase or decrease the angle of the throttle blade. The ECM sends electrical signals to the motor in the ETB to increase or decrease the airflow to the engine to control the engine speed.



Note: For a more detailed and thorough description of the Gasoline and LPG fuel systems, refer to the Diagnosis Manual ECM System WG1605 9Y110-01760.pdf.

Engine Starter Circuit Description

The starter is prevented from engaging whenever the drive pedal is NOT in the neutral position. A “Neutral relay” (K4) is in series between the key switch and the starter solenoid. When the relay is at rest (not energized) current is allowed to flow through the normally-closed contacts (30 to 87a) on to the starter. The Main Machine Controller monitors the Drive Pedal Sensor to understand the current pedal position. If it senses that the drive pedal is NOT in the neutral position, it energizes the neutral relay to break the connection between 30 and 87a. This prevents the starter from engaging.

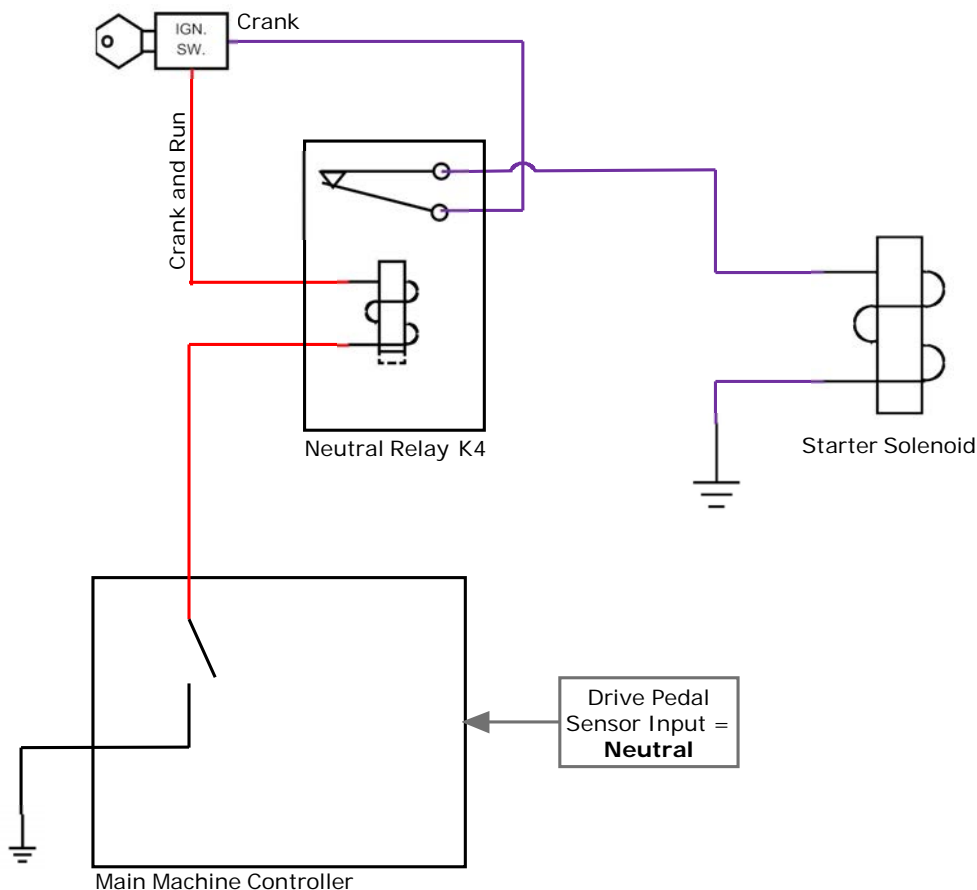

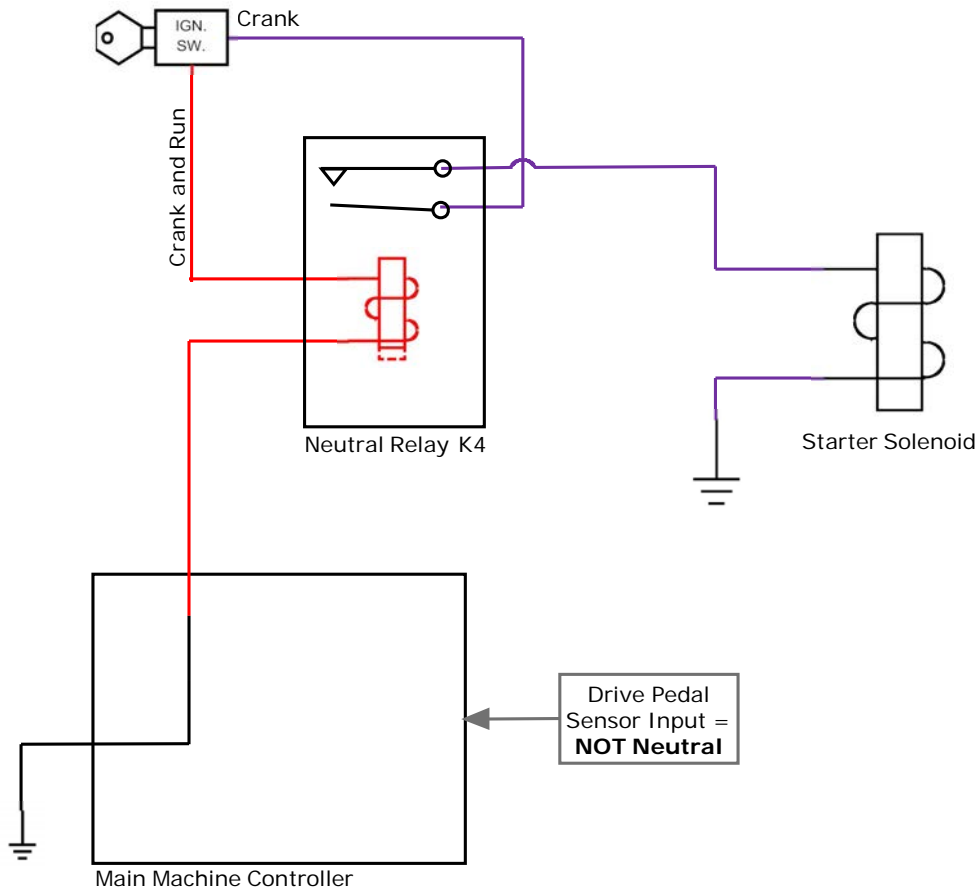

Engine Protection – Low Oil Pressure Shutdown

The engine controller monitors the oil pressure switch. If it sees a loss of oil pressure, it will shut down the engine immediately.

Engine Protection – High Temperature

The engine controller monitors the engine coolant temperature. If the temperature reaches 230 deg. F. (110 deg. C.), it will derate the engine power by 30%. If the temperature reaches 240 deg. F. (115 deg. C.), it will shut down the engine.

Engine Speed Control

The operator can request two engine speeds, “idle” and “full throttle”. The Engine Controller operates an Electronic Throttle Body to adjust and maintain engine speed according to the requested input of the Main Machine Controller. To request full throttle, the main machine controller sends out a 12v supply from J1-17 on the GRA/BLU wire to the engine controller. To request idle, the main machine controller does not apply 12v; the output remains low.

Component Locations

LPG And Gasoline Engine Common Electrical Components

The following components are included in this section: (Most photos are of LPG Engine)

- Alternator
- Electronic Throttle Body
- Cam Position Sensor
- Connector 1
- Connector 2
- Crank Position Sensor
- Diagnostic Connector
- Engine Control Module
- Engine Coolant Sensor
- Ground
- Ignition Coils
- Knock Sensor
- Oil Pressure Switch
- Post Catalyst O₂ Sensor
- Power Relay (Inside Engine Fuse/Relay Box)
- Pre Catalyst O₂ Sensor
- Starter
- Starter Relay (Inside Engine Fuse/Relay Box)
- TMAP Sensor

Figure 1. LPG Engine Shown, Left Side

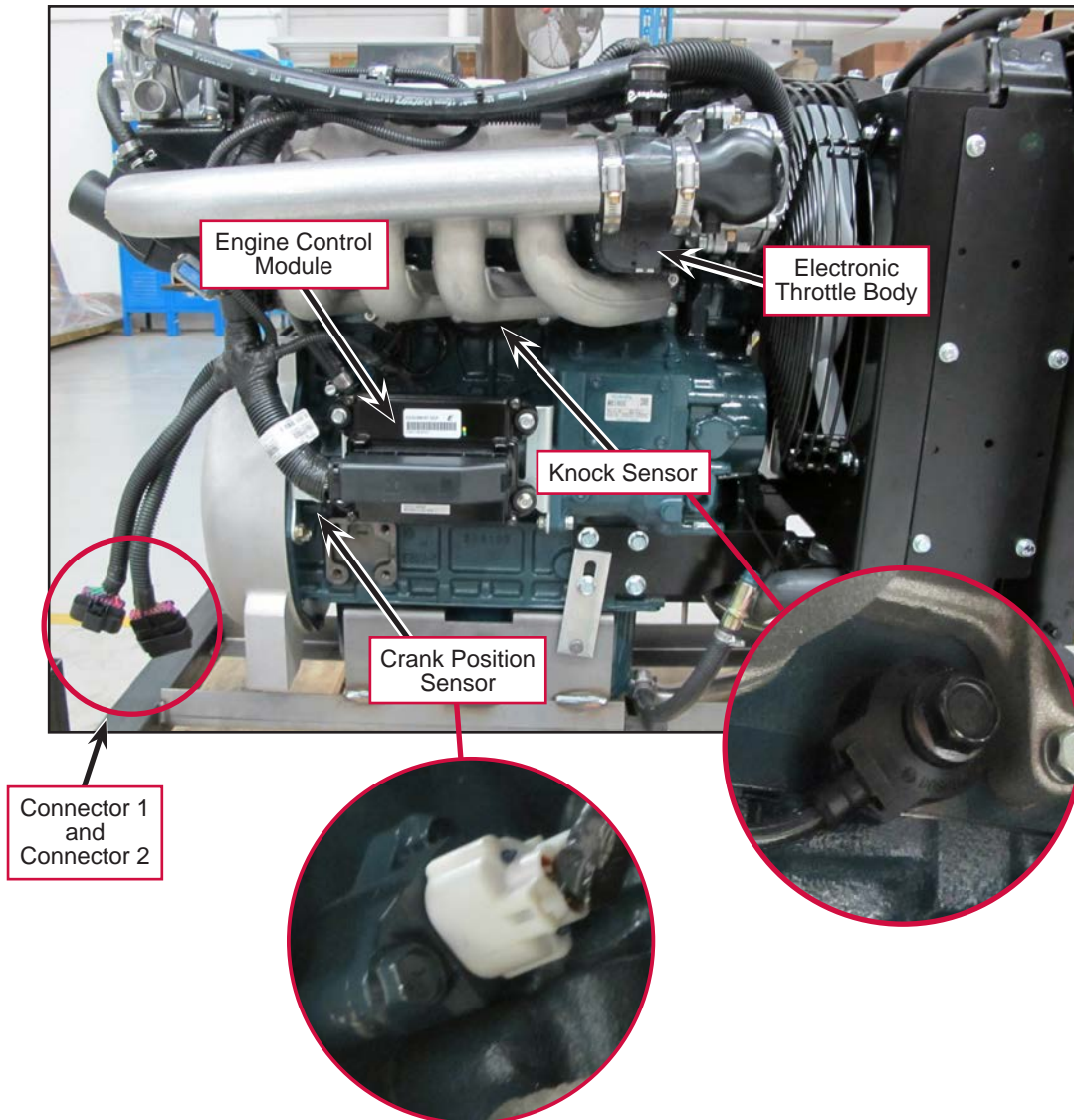

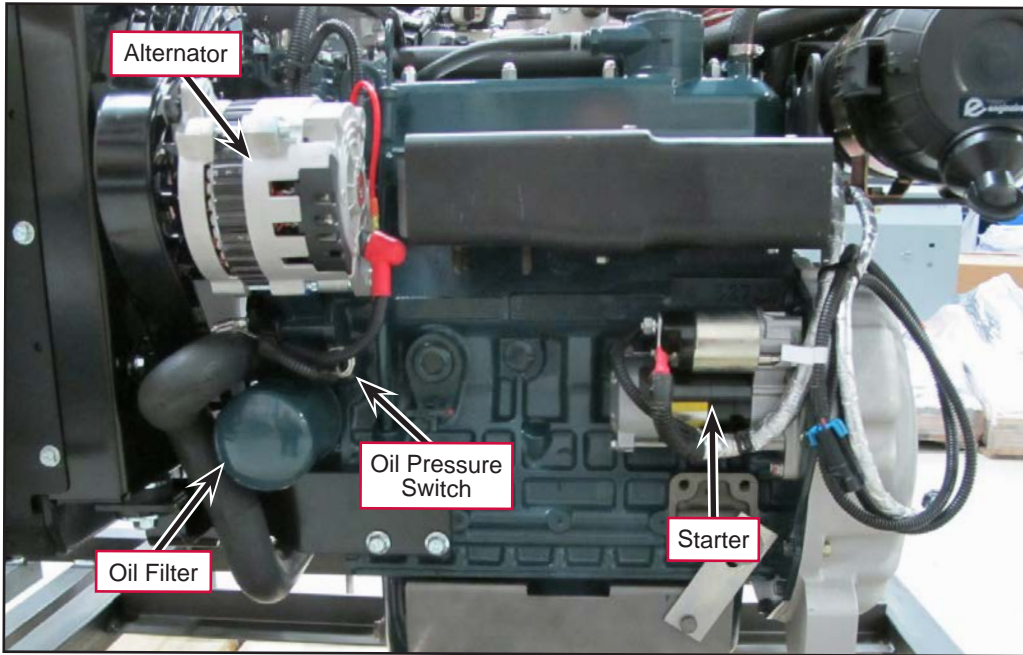

Figure 2. LPG Engine Shown - Left Side

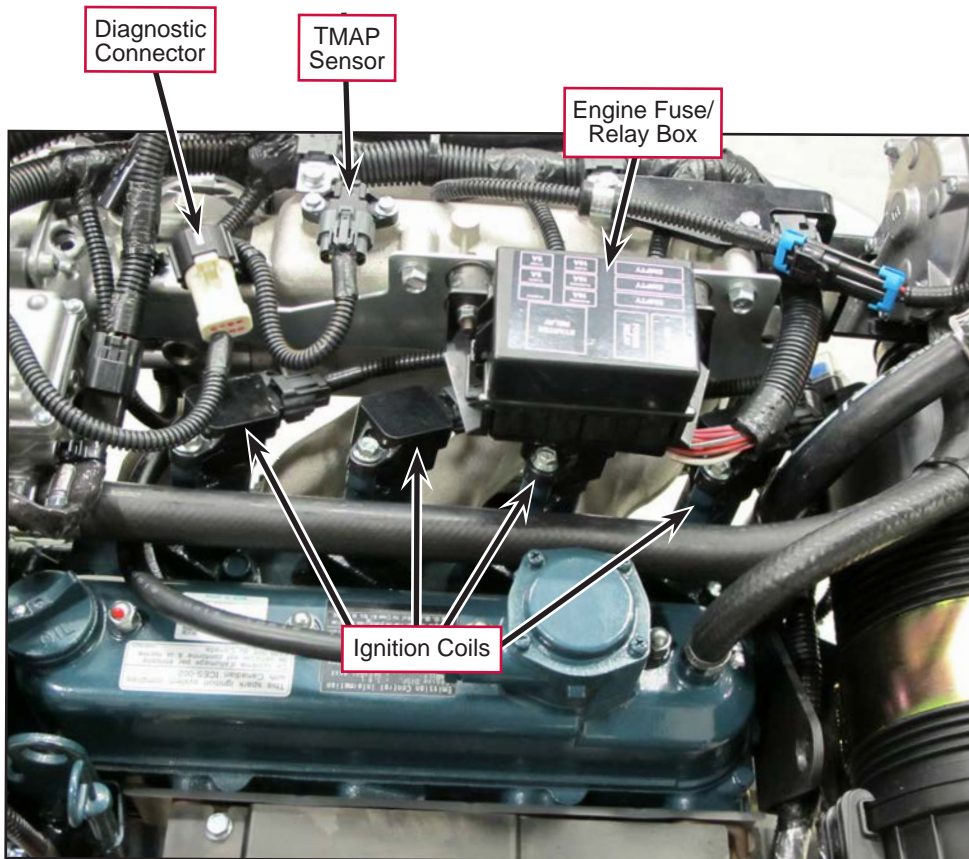

Figure 3. LPG Engine Shown, Top

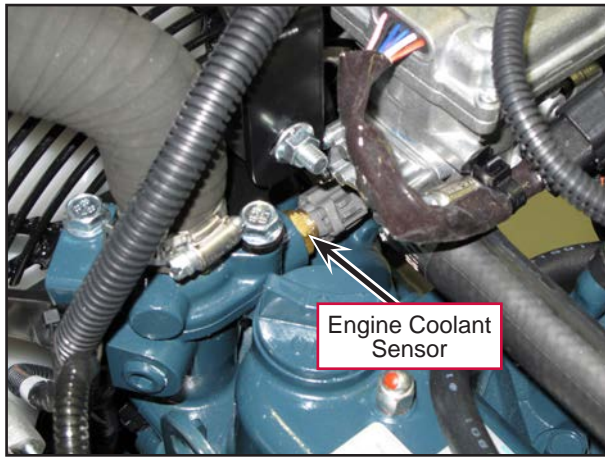

Figure 4. LPG Engine Shown - Top

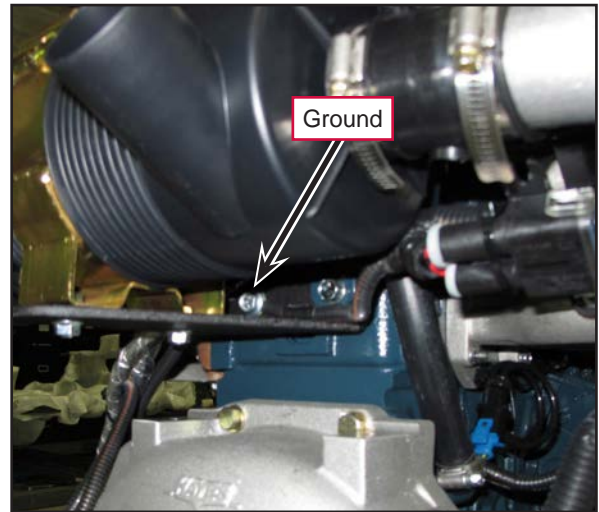

Figure 5. LPG Engine Shown - Rear, Under Air Cleaner

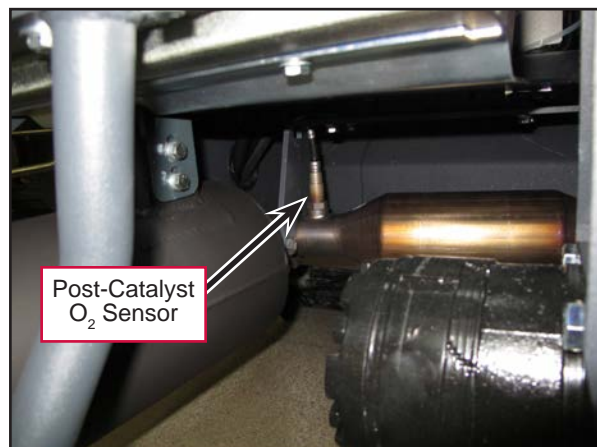
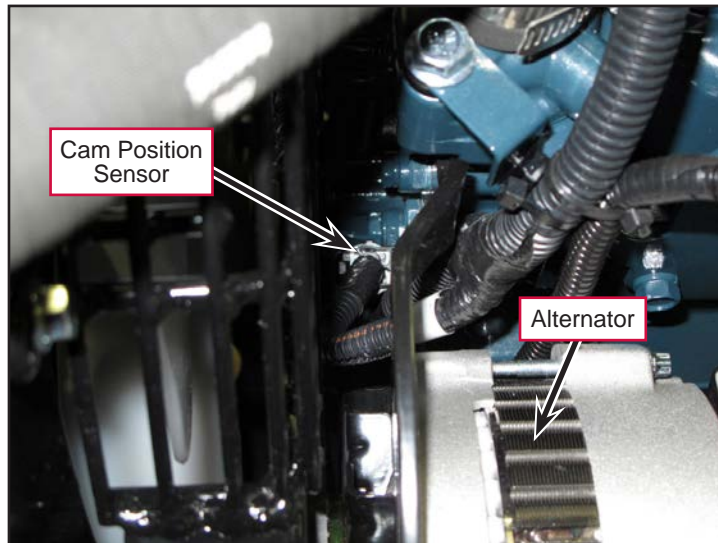
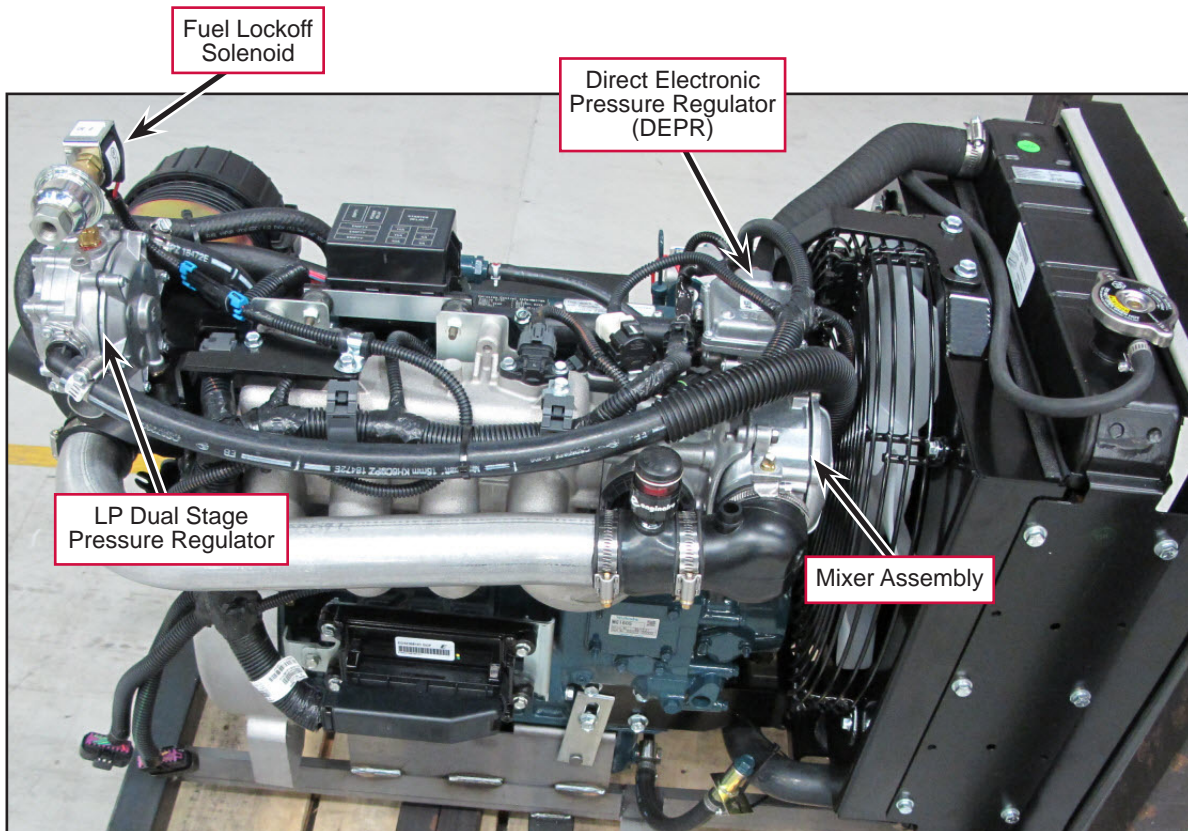

Figure 6. Oxygen Sensors

LPG ONLY Engine Electrical and Fuel Components

- Fuel Lockoff Solenoid
- DEPR - Direct Electronic Pressure Regulator
- LP Dual Stage Pressure Regulator
- Mixer Assembly



Gasoline (Petrol) ONLY Engine Electrical and Fuel Components

- Fuel Injectors
- Fuel Pump Relay (Inside Engine Fuse/Relay Box)
- Gasoline Sensor Interface (On top of fuel tank)
- Fuel Pump (On top of fuel tank)

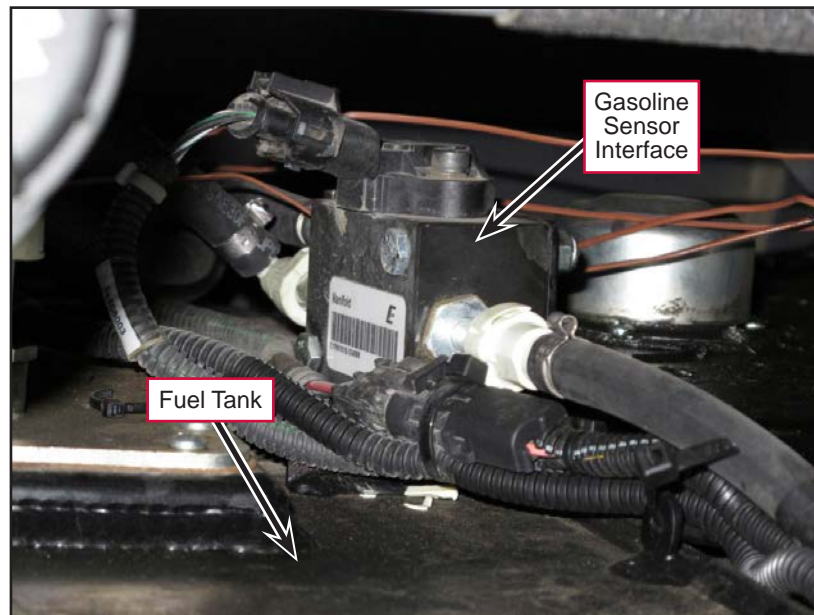
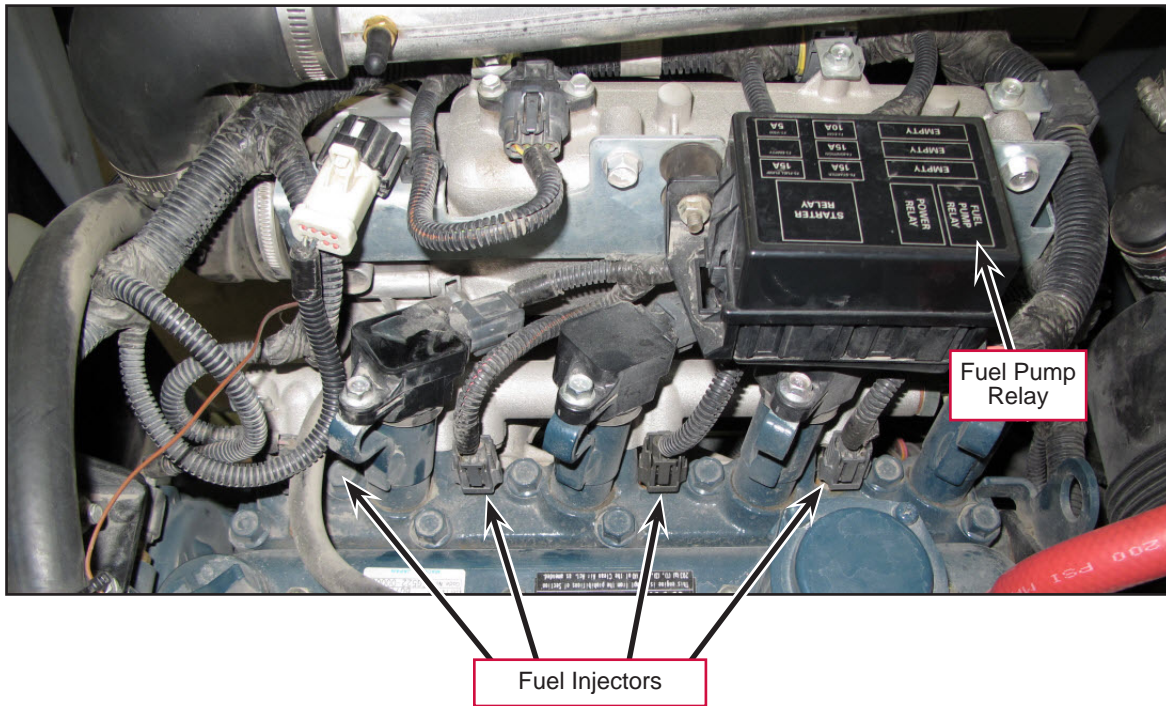

Item	Service Interval							
	Every 8 hrs (daily).	Every 50 hrs (weekly)	Every 100 hrs	Every 200 hrs	Every 1000 hrs	Every 2000 hrs	Every Year	Every Two Years
Replace intake air line								X
Replace breather hose								X
Replace LPG fuel hose and clamp bands								X
Replace coolant hose of LPG vaporizer								X
*** Check LPG vaporizer								X
Replace radiator hoses and clamp bands								X
Change radiator coolant								X
Replace battery								X

* Change the engine oil and filter cartridge after the first 50 hours of operation.

** Change more often when operating under dusty conditions.

*** If you do not have the correct tools and/or are not mechanically proficient, contact your local KUBOTA dealer.

Engine Oil

Check the engine oil level when the machine is parked on a level surface and the engine is cool. Change the engine oil after the first 50 hours of operation and every 200 hours after that. Engine oil should have properties of API classification SL or higher and be suited to the ambient temperature as listed below. Refer to the engine manufacturer's service manuals for oil capacities and additional engine specifications. Replace the oil filter with every oil change.

Temperature Range	Oil Weight
Above 77° F [25° C]	SAE30, SAE10W-30 or SAE15W-40
32° F to 77° F [0° C to 25° C]	SAE20 or SAE 10W-30
-4° F to 32° F [-20° C to 0° C]	SAE10 or SAE 10W-30

Engine Coolant

Checking Engine Coolant



Caution! Do not remove the radiator cap when the engine is hot.

To check the engine coolant level, open the engine cover and observe the coolant level in the coolant overflow tank. If the level is low, add a 50/50 mix of water and the recommended type antifreeze. Clean the radiator and oil cooler exteriors every 150 hours by washing with **low-pressure** water or using compressed air. **High-pressure water will damage the radiator.**



Service Note: The oil cooler tips out for easy cleaning of both the oil cooler and the radiator.

Replacing Engine Coolant

One possible cause of engine overheating is trapped air in the cooling system. It's recommended that you use a Cooling System Tool when changing the engine coolant. The Cooling System Tool pulls a vacuum on the cooling system prior to filling to prevent air from being trapped in the cooling system.

Note that there are several types of Cooling System Tools. The following instructions describe how to use a typical type of tool. Refer to the operating instructions included with your particular tool if different than the example shown here.

1. Connect a **Compressed Air Supply Line** to the fitting on the Cooling System Tool.
2. Connect the **Coolant Supply Line** to the Cooling System Tool. Make sure the **Coolant Valve** is closed.
3. Insert and hold the Cooling System Tool onto the radiator filler neck, then press the **Air Switch**. The compressed air travelling through the **Venturi Tube Assembly** will pull a vacuum on the cooling system to remove air from the system.
4. Once the vacuum reading on the **Gauge** reaches approximately 25 on the green scale, release the **Air Switch**. Note that this also a good opportunity to check for cooling system leaks,
5. Continue to hold the Cooling System Tool onto the radiator filler neck and open the **Coolant Valve** to allow coolant to flow into the radiator.
6. Once the pressure on the **Gauge** reaches approximately 5 on the red scale and the radiator is almost full, shut off the **Coolant Valve** and remove the Cooling System Tool from the radiator filler neck.
7. Top off the radiator and overflow tank as necessary.

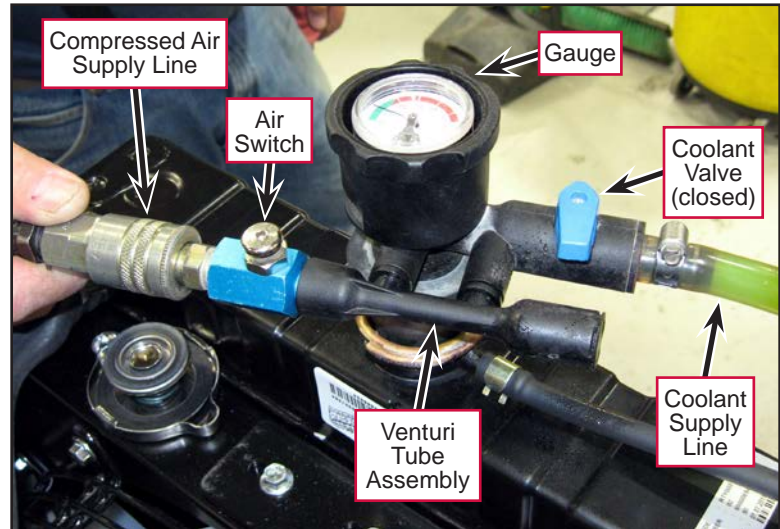

Removing the Air from the Cooling System with Cooling System Tool

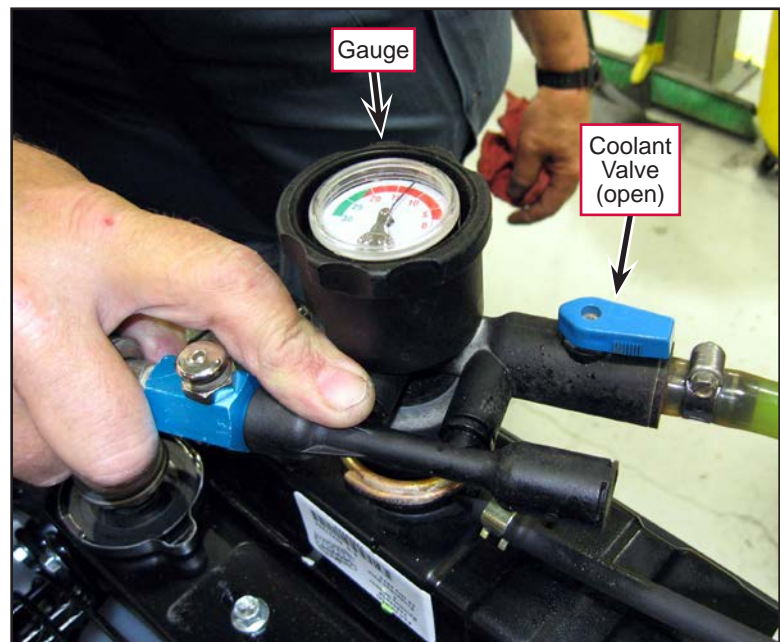

Filling Cooling System with Coolant

Engine Air Filter Maintenance



Caution! When servicing the engine air filter elements, use extreme care to prevent loose dust from entering the engine. Dust can severely damage the engine.

Service the air cleaner more frequently under severe dusty or dirty conditions.

1. Remove the air cleaner elements from the air cleaner assembly and inspect them for foreign material restrictions or signs of excessive wear or damage. Replace the elements if necessary.
2. Remove all dust and foreign matter from the air cleaner housing.
3. Reinstall the air cleaner elements.
4. Reinstall the air cleaner cup, then securely fasten the retaining clips

Troubleshooting

The EControls engine management package supports robust self diagnostics and is capable of setting scores of Diagnostic Trouble Codes (DTCs). DTCs and sensor data can be viewed on a coputer using the “GCP Display” software along with an “ECom” communication cable. See the Diagnosis Manual ECM System WG1605 9Y110-01760.pdf for the diagnostic tool connection procedure.

The ECom cable can be purchased through Nilfisk-Advance. (See Special Tools in this section for the part number). It is the same cable that has been used on other recent Nilfisk-Advance machines using the GM 1.6L and GM 3.0L engines. You will need a new version of the GCP software to work with the Kubota WG1605 engine along with the correlating password. The software, password and installation instructions can all be downloaded from “Customer Zone” at www.advance-us.com.

Most or all engine troubleshooting is covered in Kubota manuals. There are some things specific to the SW8000 engine application which are covered here in this manual section such as, engine speed control and engine starter operation.



Note: Refer to the Diagnosis Manual ECM System WG1605 9Y110-01760.pdf, for engine troubleshooting information and procedures including all fault code diagnosis.

General Troubleshooting

Problem	Cause	Correction
The engine will not crank.	Weak battery, poor battery cable connections.	<ul style="list-style-type: none"> • Check the battery and connections and clean/repair as necessary. • Check the wiring from the battery to the Starter B+ terminal on the A3 Engine System and repair as necessary.
	No power to the Starter Solenoid (Starter Command circuit)	<ul style="list-style-type: none"> • Make sure the foot pedal is in the neutral position. • Reset the foot pedal deadband position if necessary. (Refer to the Control System, / Main Machine Controller Programming section.) • Make sure there is continuity through the Neutral Relay K4 contacts 30 and 87a (relay off). • Check the starter relay operation • Check circuit breaker CB1 and reset if necessary. • Check circuit breaker CB3 and reset if necessary.

Problem	Cause	Correction
The engine will not start.	No power to the Ign. Switch Input terminal on the A3 Engine System.	<ul style="list-style-type: none"> • Check circuit breaker CB5 and reset if necessary. • Check the continuity from the Ignition Switch to the Ign. Switch Input terminal on the A3 Engine System and repair as necessary.
Engine will not run at high speed.	Loss of throttle input from Main Machine Controller to Engine Controller Engine System Problem	<ul style="list-style-type: none"> • Check that a voltage signal is being sent to the engine controller when the Throttle Switch is set to operating speed. • Refer to <i>Diagnosis Manual ECM System WG1605 9Y110-01760.pdf</i>
The engine stops running, check engine light is on.	The coolant temperature is too high.	Refer to the Engine Overheating Problems section below.
	The oil pressure has dropped too low.	Refer to the Loss of Oil Pressure Protection section below.
	Engine Management System Problem	Consult <i>Diagnosis Manual ECM System WG1605 9Y110-01760.pdf</i>

Engine Overheating Problems

Use the checklist below as a guide to thoroughly check the engine cooling system.

- Check the coolant level in the overflow tank and radiator.
- Inspect and clean the radiator and hydraulic oil cooler.
- Check for correct operation of the belt-driven engine cooling fan (slippage).
- Check to see that the engine thermostat opens.
- Check for correct water pump operation.
- Check the engine crankcase oil level.
- Check for air trapped in the cooling system. (Refer to the **Engine Coolant/Replacing Engine Coolant** section.)
- Check the engine coolant sensor for correct function as replace if necessary.
- Check for combustion gasses in the cooling system.

Specifications

Model	WG1605-G-E3	WG1605-L-E3
	Gasoline fuel	LPG fuel
Number of Cylinders	Four	
Type	Vertical, water cooled, four-cycle Gasoline engine	Vertical, water cooled, four-cycle LPG engine
Bore × Stroke	79.0 × 78.4 mm (3.11 × 3.09 in.)	
Total Displacement	1.537 L (93.79 cu.in.)	
Cylinder Head	Overhead-Valve	
Ignition System	Full Transistor Battery Ignition Type	
Governor	Electronic Governor	
Direction of Rotation	Counterclockwise (Viewed from Flywheel Side)	
Spark Plug Type/Spark Plug Gap	NGK IFR6F8DN; 0.70 to 0.80 mm (0.028 to 0.031 in.)	
Ignition Timing.	0.45 rad (26 °) before T.D.C. 3000 min-1 (rpm), 3600 min-1 (rpm)	0.35 rad (20 °) before T.D.C. 3000 min-1 (rpm), 3600 min-1 (rpm)
	0.17 rad (10 °) before T.D.C. 750 min-1 (rpm), 800 min-1 (rpm)	0.17 rad (10 °) before T.D.C. 750 min-1 (rpm), 800 min-1 (rpm)
Firing Order	1-3-4-2	
Compression Ratio	9.1: 1	
Lubricating System	Forced Lubrication by Trochoid Pump	
Oil Pressure Indication	Electrical Type Switch	
Engine Oil Pressure (Hot)	Factory Specification	Allowable Limit
At Idle Speed	49 kPa	-
	0.50 kgf/cm ²	
	7.1 psi	
At Rated Speed	196 to 441 kPa	147 kPa
	2.00 to 4.49 kgf/cm ²	1.50 kgf/cm ²
	28.5 to 63.9 psi	21.3 psi
Lubricating Filter	Full Flow Paper Filter (Cartridge Type)	
Cooling System Type	Pressurized Radiator, Forced Circulation with Water Pump	
Starting System	Electric Starting with Starter	
Starting Motor	12 V, 1.0 kW	
Battery	12 V, 52 AH or Equivalent	
Charging Alternator	12 V, 480 W, 720 W	
Fuel	Unleaded Automobile Gasoline	Commercial LPG
Lubricating Oil	Better than SL Class (API) SAE 10W-30	
Lubricating Oil Capacity	6.0 L (1.6 U.S.gals)	
Catalytic Muffler / Converter	Three-way Catalyst	
Weight (Dry)	119 kg (262 lbs)	120 kg (265 lbs)
Kubota Recommended LPG Fuel Specifications		Commercial Propane gas only, Equivalent to Propanes H-D-5 of GPA* standards

Shop Measurements

The following information was gathered by measuring one machine. While the values recorded cannot serve as “true specifications” they may help you recognize what normal looks like and give you some standard of comparison.

Engine Vacuum

17.5-18 “HG (59-61kPa)-at warm idle. Measured at approximately 900 ft. elevation

LP Fuel Pressure

- Primary - Approximately 3 psi (20 kPa)
- Secondary - Approximately 1 psi (7 kPa)



Ignition Output

30 KV while cranking

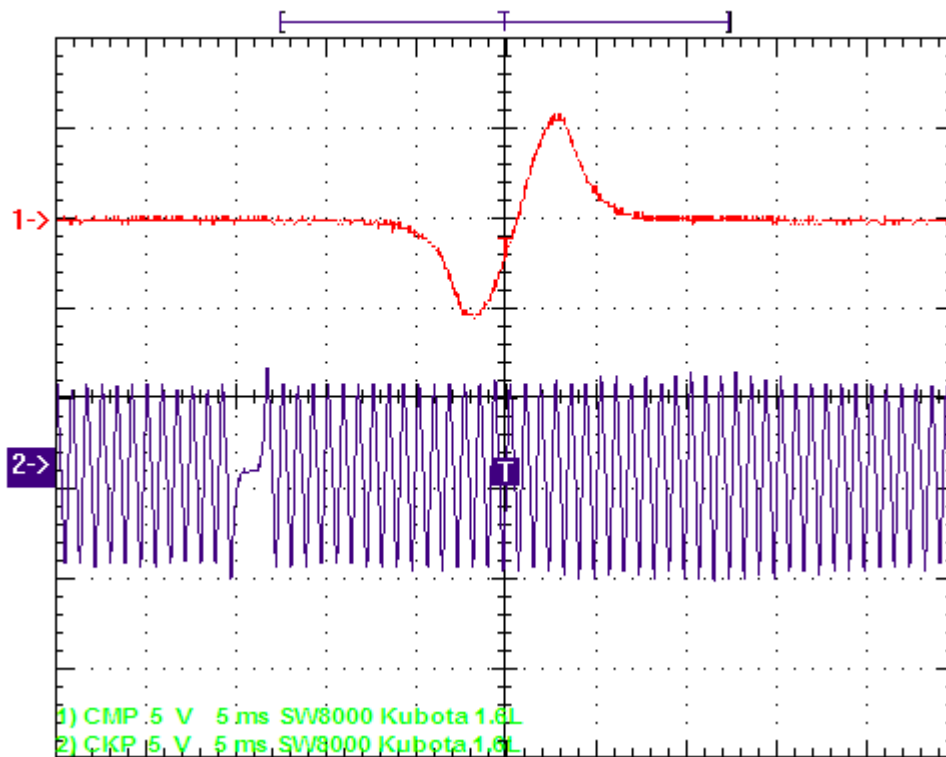
Cam Sensor and Crank Sensor Oscilloscope Pattern



Special Tools

<p>Diagnostic Communication Cable and software, p/n 56305647</p>  <p><i>Note: The “Ecom” cable is used but the software on the CD is for the GM engines. New software must be ordered or downloaded from Customer Zone to use on the Kubota engine.</i></p>	
<p>Cooling System Tool</p>	
<p>CD containing Kubota Engine Software p/n 56107764</p>	<p>Not Shown</p>

Hopper System

Functional Description

Overview

The hopper holds the dust and debris swept up by the brooms. A hydraulic cylinder raises the hopper for emptying into a dumpster or other receptacle. A second hydraulic cylinder opens and closes the hopper door to allow the Operator to empty the hopper. The dust control system pulls air from the hopper through the hopper filter to reduce the dust generated from sweeping. Refer to the **Dust Control System** section for more information on the dust control components.

Hopper

The **Hopper** is supported by the **Hopper Lift Arm Weldment**. The **Hopper Lift Arm Weldment** pivots in the chassis to allow the **Hopper** to swing up and down.

The **Hopper Lift Cylinder** is attached to the **Hopper Lift Arm Weldment** and chassis, and extends and retracts to raise and lower the **Hopper**.

The mechanical **Prop Rod** can be engaged to prevent the **Hopper** from being lowered, or from dropping accidentally if there's a problem with the hydraulic system.

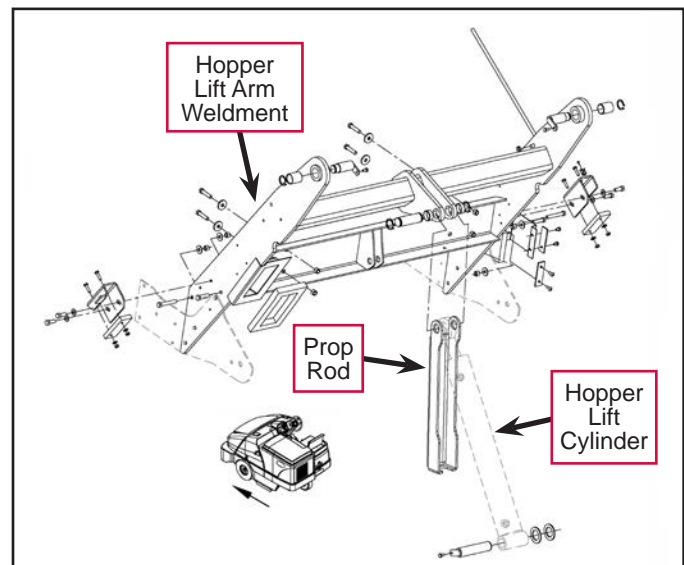
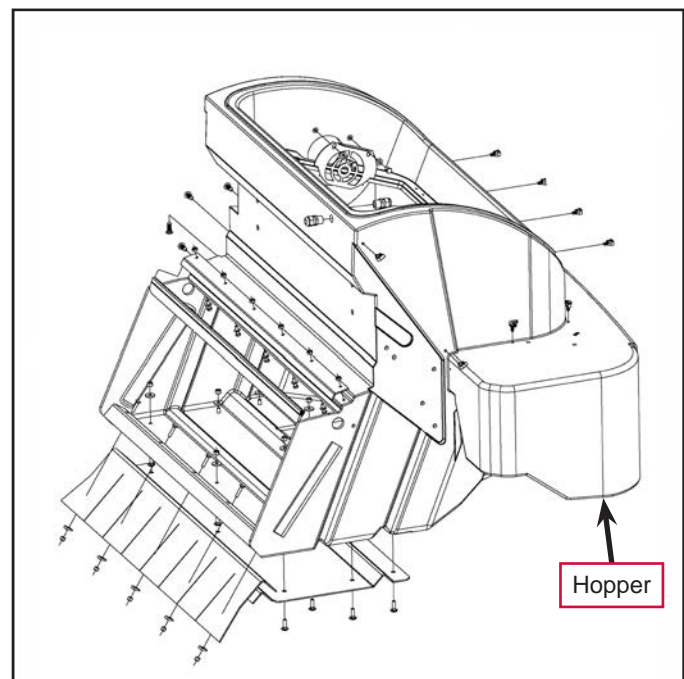

Hopper Door

The **Hopper Door** is attached to the **Hopper Door Pivot**. The **Hopper Door Pivot** is mounted to the two **Side Broom Arm Brackets** to allow the **Hopper Door** to open and close.

The **Hopper Door Cylinder** is attached to the **Hopper Door** and hopper lift arm weldment, and extends and retracts to open and close the **Hopper Door**.

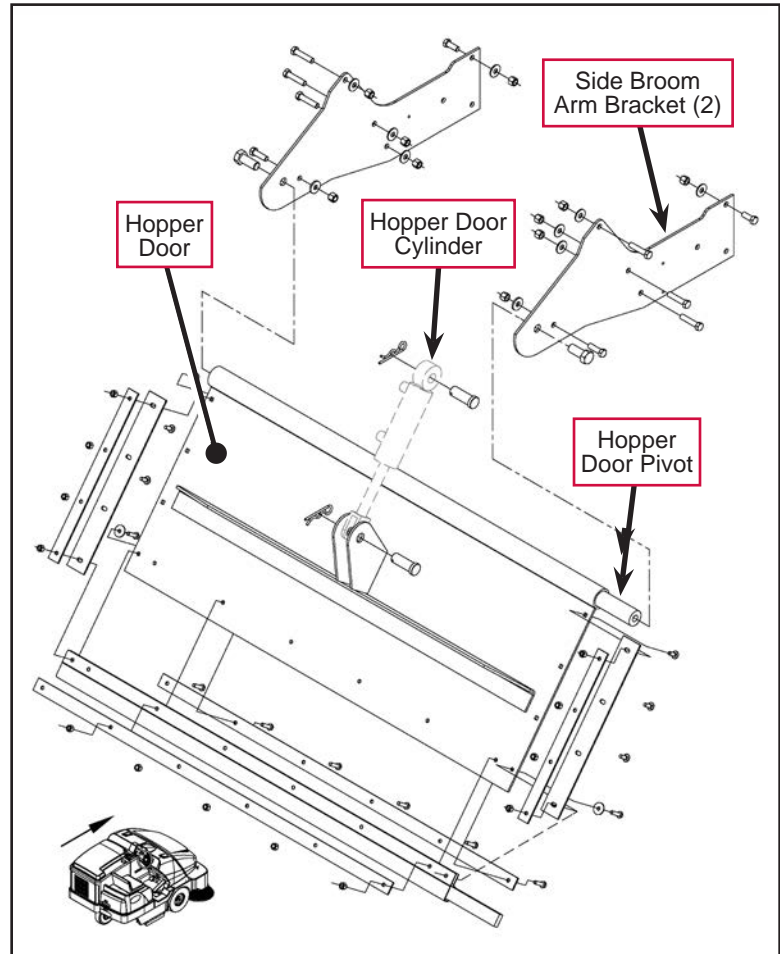

Hopper Hydraulic System

The hydraulic solenoid valves that control the **Hopper Lift Cylinder** and **Hopper Door Cylinder** are in the **Hydraulic Manifold Assembly**. The solenoid valves are electrically energized by pressing the corresponding switches on the control panel.

The hopper lift cylinder is connected to ports **M** and **N** on the **Hydraulic Manifold Assembly**.

The **S5 Hopper Up/Down**, **S6 Hopper Up Bypass** and the **S9 Hopper Lower** solenoid valves control the hopper lift cylinder.

The hopper door cylinder is connected to ports **B** and **C** on the **Hydraulic Manifold Assembly**.

The **S1 Hopper Close/Open** and **S7 Hopper Open** solenoid valves control the hopper door cylinder.

Note that:

- The **S4** solenoid valve is only installed on machines equipped with the Litter Vac Kit.
- On machines without the Litter Vac Kit, a captive plug is installed in the **S4** location in the **Hydraulic Manifold Assembly**.

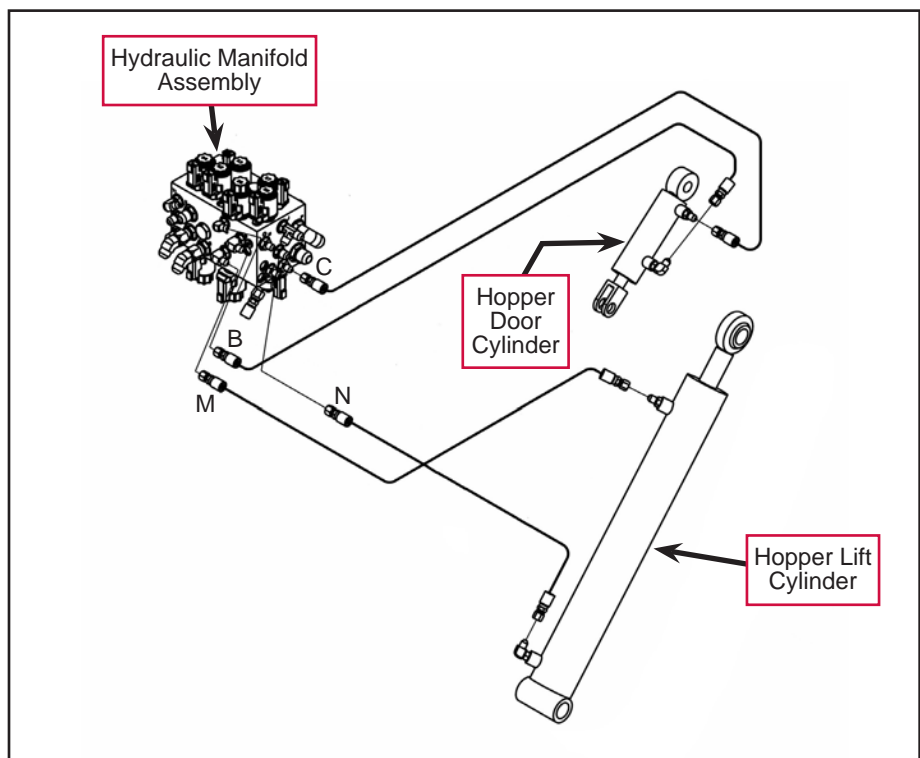
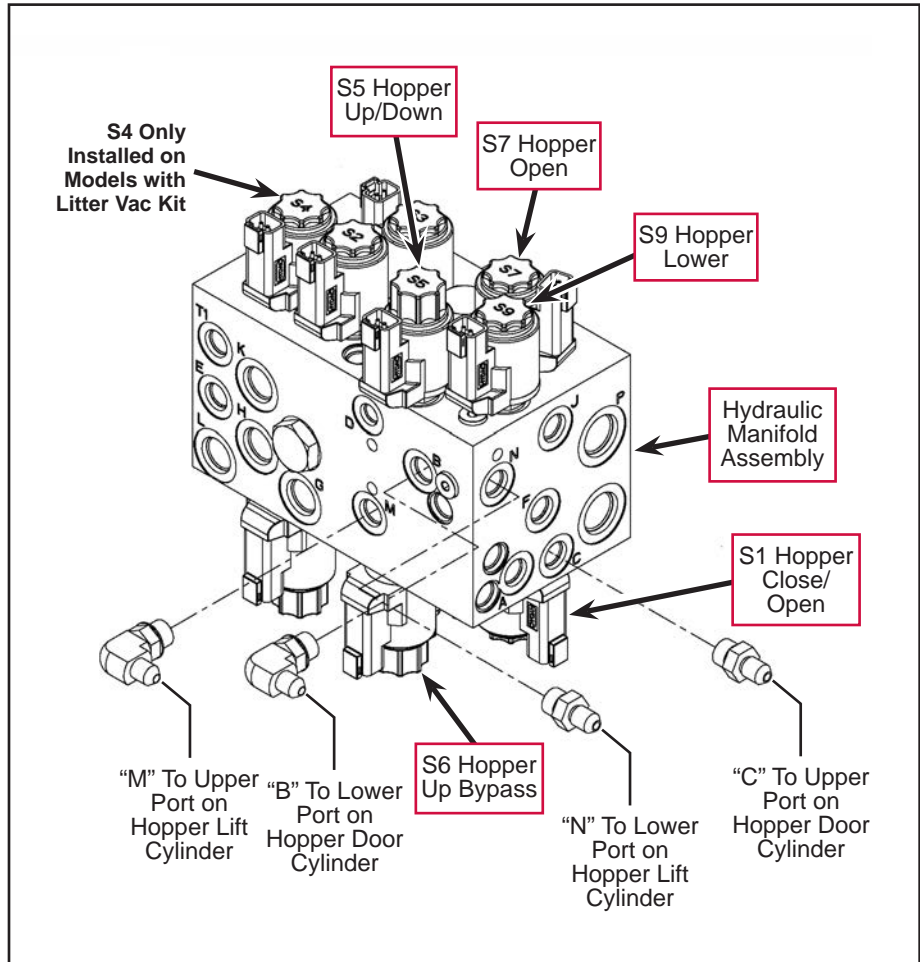

Hopper System Wiring Diagram

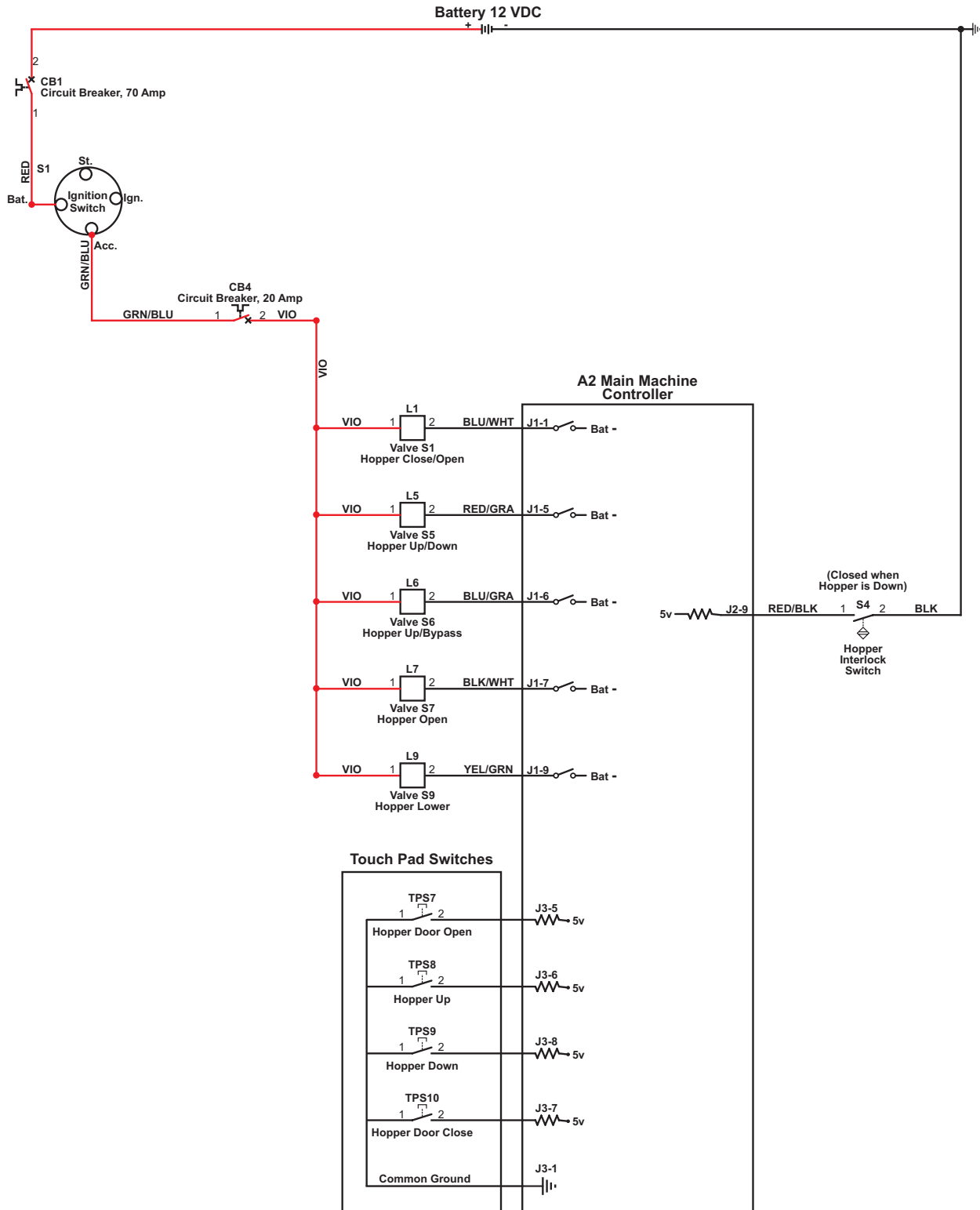

Hopper System Circuit Description

Positive voltage is provided to hopper solenoid valves **S1**, **S5**, **S6**, **S7** and **S9** when the **Ignition Switch** is on. The **A2 Main Machine Controller** will ground and energize the solenoid valve corresponding to the function selected by the Operator via the **Touch Pad Switches**.

- The **Hopper Interlock Switch, S4**, must be closed (hopper down) before the sweeping functions can be enabled.
- The **Hopper Interlock Switch, S4**, must be open (hopper up) before the hopper door can be opened or closed manually.



Note: *The **A2 Main Machine Controller** programming logic for the hopper functions works as follows:*

- *The engine needs to be at the high-speed setting in order to raise or lower the hopper.*
- *The **A2 Main Machine Controller** will automatically open the hopper door when the main broom is on (lowered).*
- *The **A2 Main Machine Controller** will automatically close the hopper door when the main broom is off (raised) or when the hopper is not down.*
- *The hopper door cannot be closed manually when the main broom is on and the hopper is down.*
- *The hopper must not be down and the main broom must be off in order for the hopper door to be opened or closed manually.*
- *The main broom is turned off automatically and the hopper door is closed automatically when the hopper is raised (not down).*

Hopper System Hydraulic Diagrams

Hopper Down, Hopper Door Closed

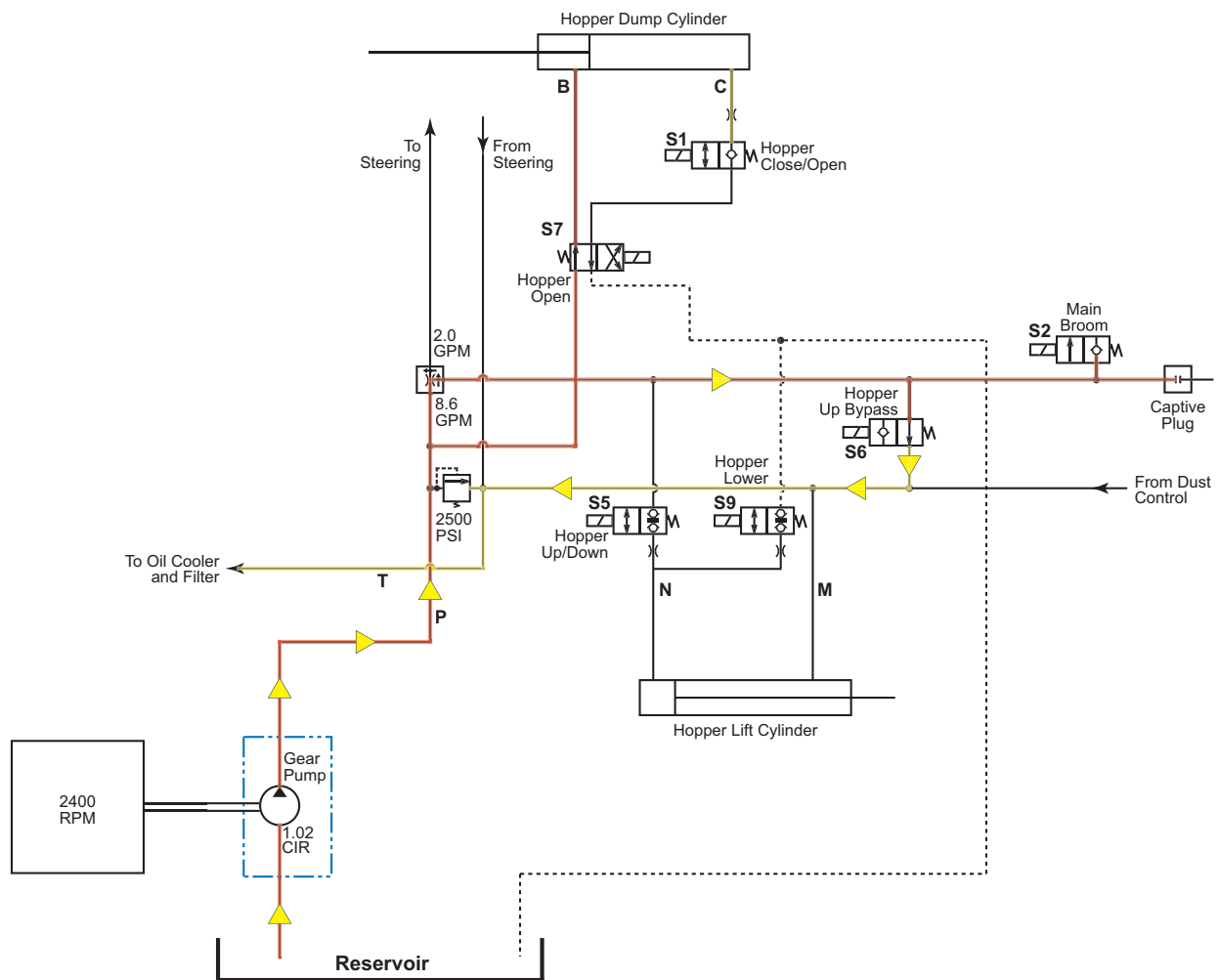

When the hopper is down and the main broom is off, the hydraulic oil from the **Gear Pump** passes through the **8.6 GPM** splitter, through the de-energized **Hopper Up Bypass** solenoid valve, **S6**, then through the return lines to the **Oil Cooler** and **Filter**.

When the hopper door is closed, the hydraulic oil from the **Gear Pump** passes through the de-energized **Hopper Open** solenoid valve, **S7**, then to the retract (lower) port, **B**, on the extended **Hopper Dump Cylinder**. The check valve on the de-energized **Hopper Close/Open** solenoid valve, **S1**, blocks the oil flow through the **Hopper Dump Cylinder** to keep the **Hopper Dump Cylinder** extended and the hopper door closed.

Lower Hopper

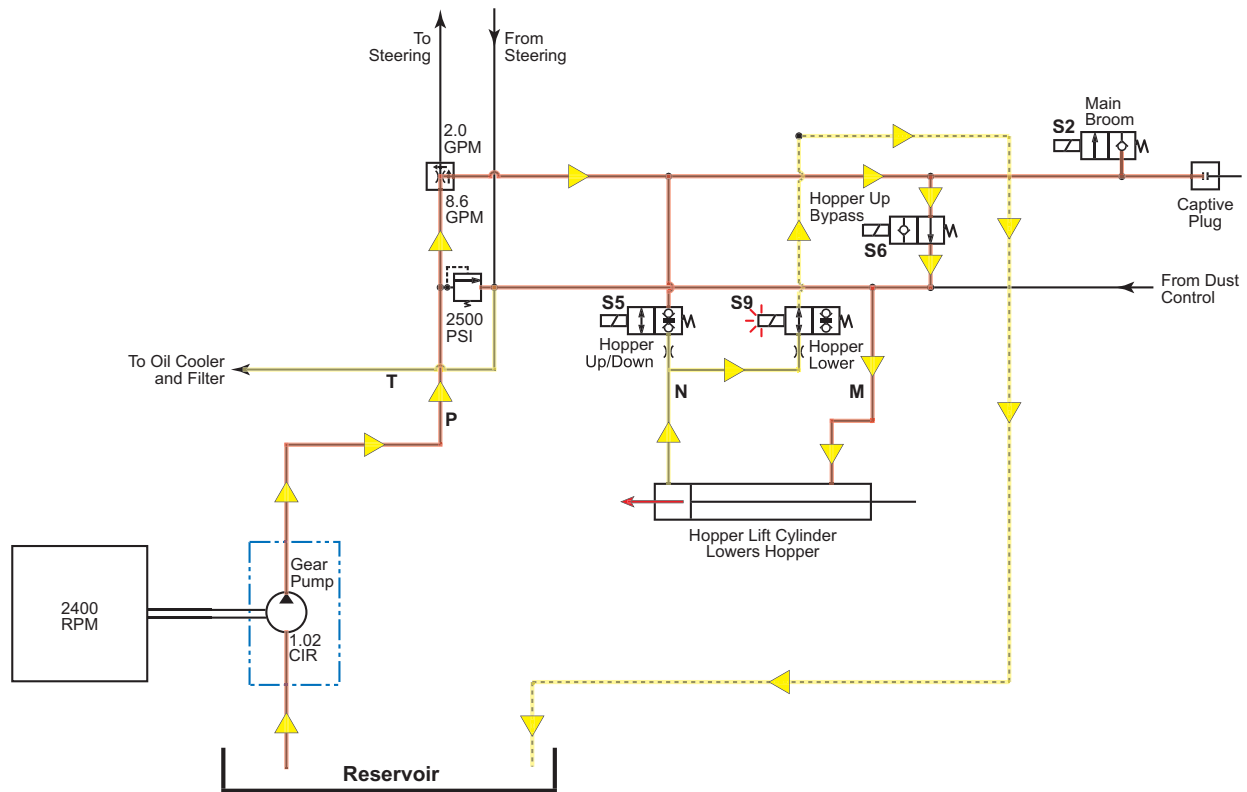

- When the Lower Hopper Switch on the control panel is pressed, the A2 Main Machine Controller energizes the **Hopper Lower** solenoid valve, **S9**.
- The hydraulic oil is directed through the de-energized **Hopper Up Bypass** solenoid valve, **S6**, then to the retract (upper) port, **M**, on the **Hopper Lift Cylinder** to lower the hopper. The check valves in the de-energized **Hopper Up/Down** solenoid valve, **S5**, block the oil to and from the extend (lower) port, **N**, on the **Hopper Lift Cylinder**. The hydraulic oil also “deadheads” at the check valve in the de-energized **Main Broom** solenoid valve, **S2**, and at the **Captive Plug** in the pressure line.
- The oil from the extend (lower) port, **N**, on the **Hopper Lift Cylinder** goes through the energized **Hopper Lower** solenoid valve, **S9**, then returns to the **Reservoir**.

Open Hopper Door

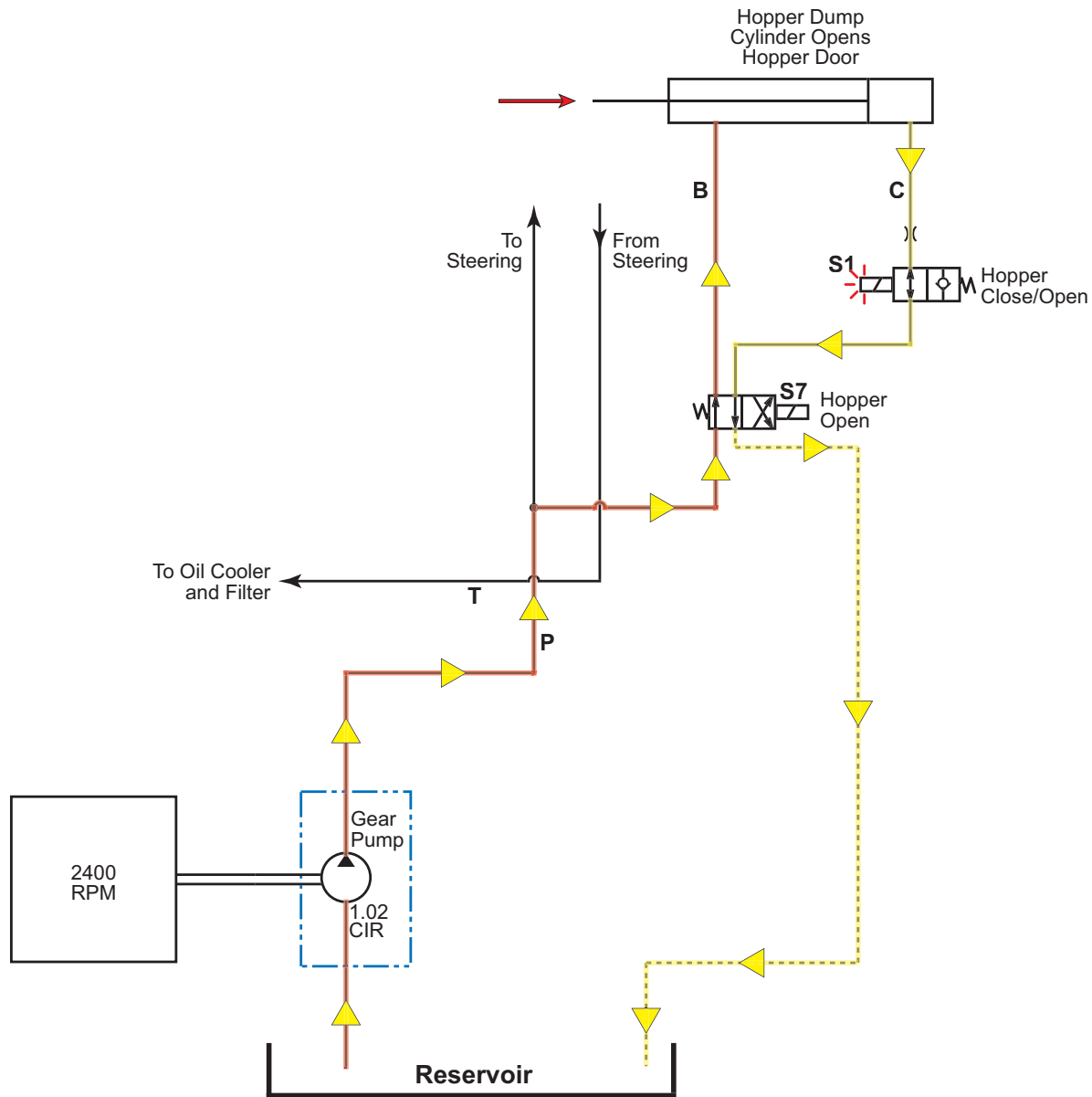

Note: The hopper door can only be opened and closed manually when the hopper is not down.

The hopper door opens automatically when the hopper is down and the main broom is on.

- When the Open Dump Door Switch on the control panel is pressed, the A2 Main Machine Controller energizes the **Hopper Close/Open** solenoid valve, **S1**.
- The hydraulic oil goes through the de-energized **Hopper Open** solenoid valve, **S7**, then to the retract (lower) port, **B**, on the **Hopper Dump Cylinder** to open the hopper door.
- The oil from the extend (upper) port, **C**, on the **Hopper Dump Cylinder** goes through the energized **Hopper Close/Open** solenoid valve, **S1**, through the de-energized **Hopper Open** solenoid valve, **S7**, then returns to the **Reservoir**.

Close Hopper Door

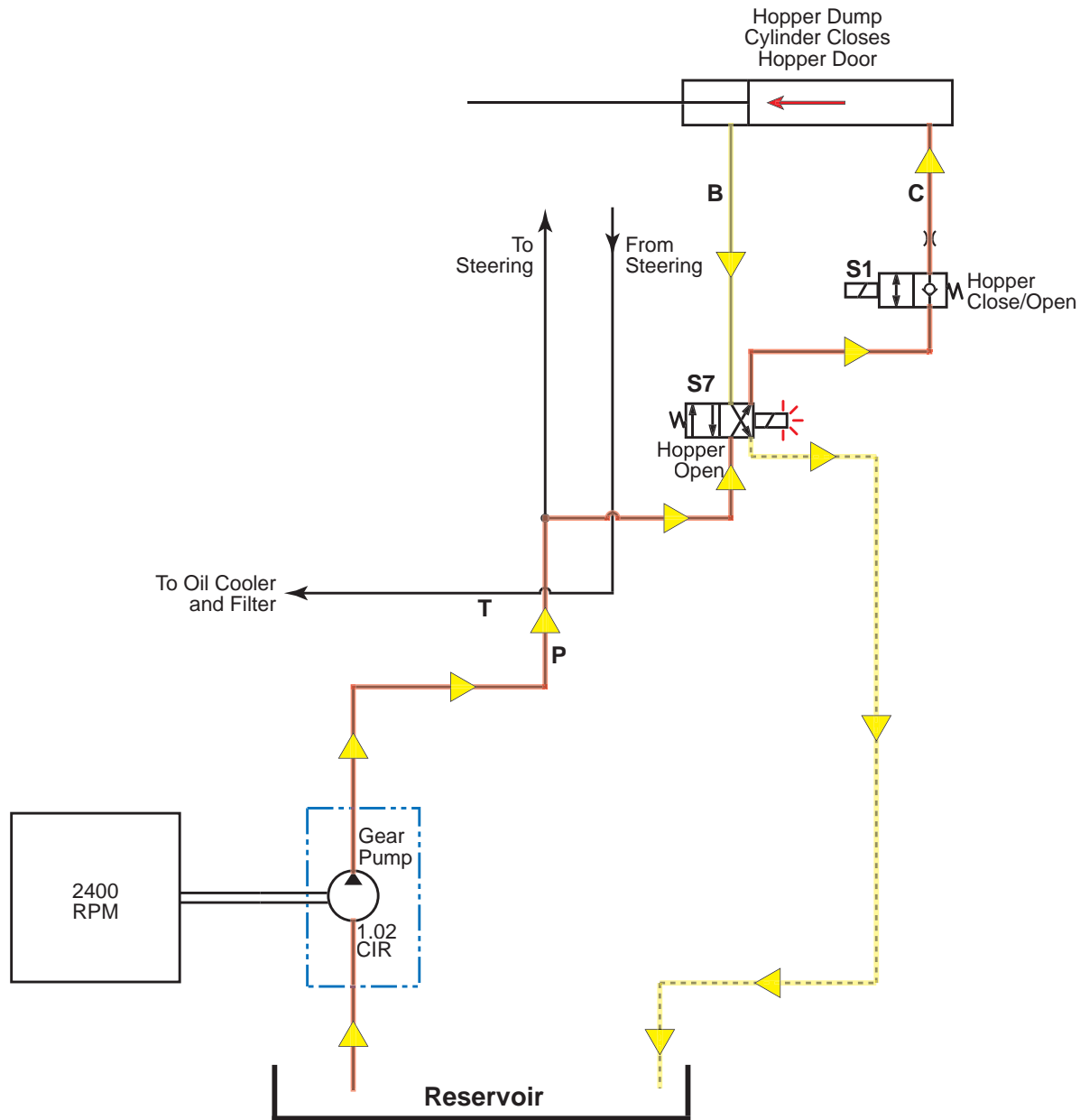

Note: The hopper door can only be opened and closed manually when the hopper is not down.

The hopper door closes automatically when the broom is off or the hopper is raised.

- When the Close Dump Door Switch on the control panel is pressed, the A2 Main Machine Controller energizes the **Hopper Open** solenoid valve, **S7**.
- The hydraulic oil is directed through the energized **Hopper Open** solenoid valve, **S7**, through the check valve in the de-energized **Hopper Close/Open** solenoid valve, **S1**, then to the extend (upper) port, **C**, on the **Hopper Dump Cylinder** to close the hopper door.
- The oil from the retract (lower) port, **B**, on the **Hopper Dump Cylinder** goes through the energized **Hopper Open** solenoid valve, **S7**, then returns to the **Reservoir**.

Component Locations

The following components are included in this section:

- Hopper
- Hopper Lift Cylinder
- Hopper Door Cylinder
- Hopper Interlock Switch
- Hopper Prop Rod
- Hydraulic Manifold Assembly and Solenoid Valves

Hopper

The **Hopper** is on the front of the machine and holds the dust and debris swept up by the brooms. The hopper also houses the dust control system components (panel filter, panel filter shaker assembly, vacuum fan assembly, etc.). Refer to the **Dust Control System** section for details on the Dust Control System.

The **Hopper Cover** lifts up to allow access to the dust control system components.

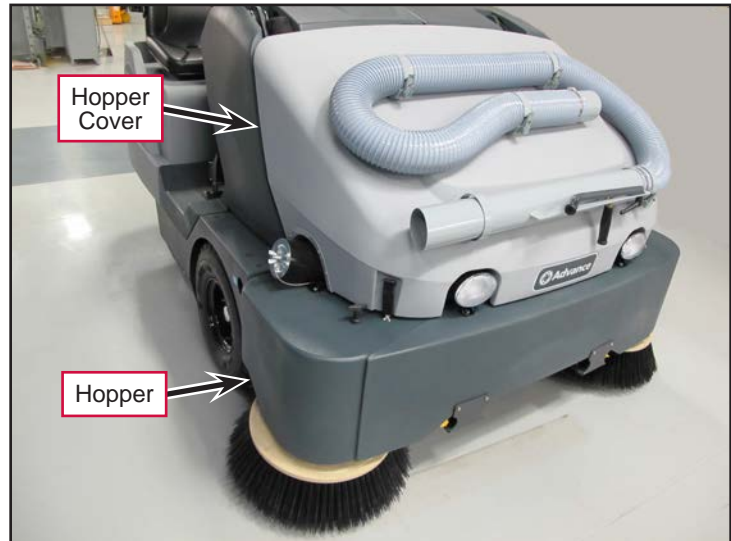

Hopper Interlock Switch

The **Hopper Interlock Switch (S4)** is a proximity switch that “closes” when the hopper is fully down. The switch is mounted on the left side of the machine above the left front wheel. This switch must be closed in order for the sweeping functions to be enabled.

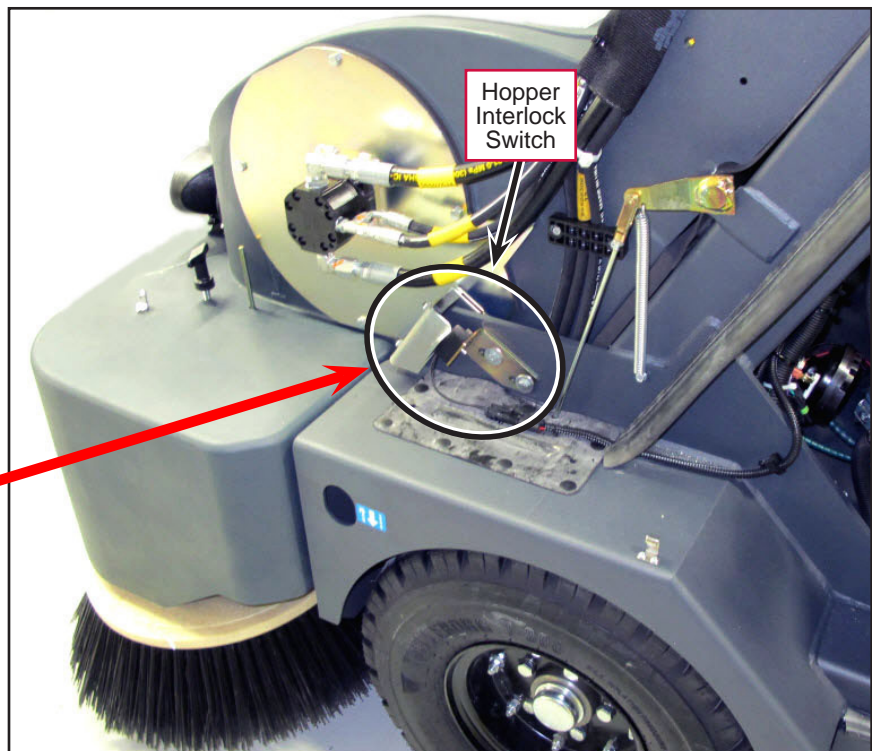

Hopper Lift Cylinder

The **Hopper Lift Cylinder** is attached to the machine frame and hopper, and raises and lowers the hopper.

Hopper Prop Rod

The **Prop Rod** must be engaged whenever personnel are working on or underneath the hopper. The **Prop Rod** prevents the hopper from being lowered, or from dropping down accidentally if there's a failure in the hydraulic system.



Warning! Never work under the hopper without first engaging the Prop Rod.

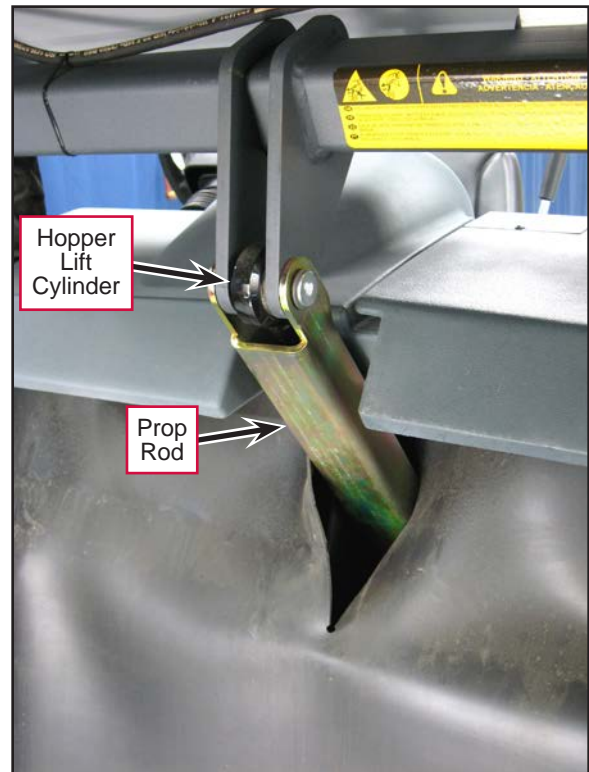

To engage the **Prop Rod**:

1. Raise the hopper to its full-up position.
2. Pull the **Hopper Safety Support Handle** toward the rear of the machine to retract the **Prop Rod** to the engage position (as shown in the adjacent photo).
3. Lower the hopper to engage the **Prop Rod**.

To disengage the **Prop Rod**.

1. Raise the hopper to its full-up position.
2. Push the **Hopper Safety Support Handle** toward the front of the machine to extend the **Prop Rod** to the disengage position.
3. Lower the hopper.

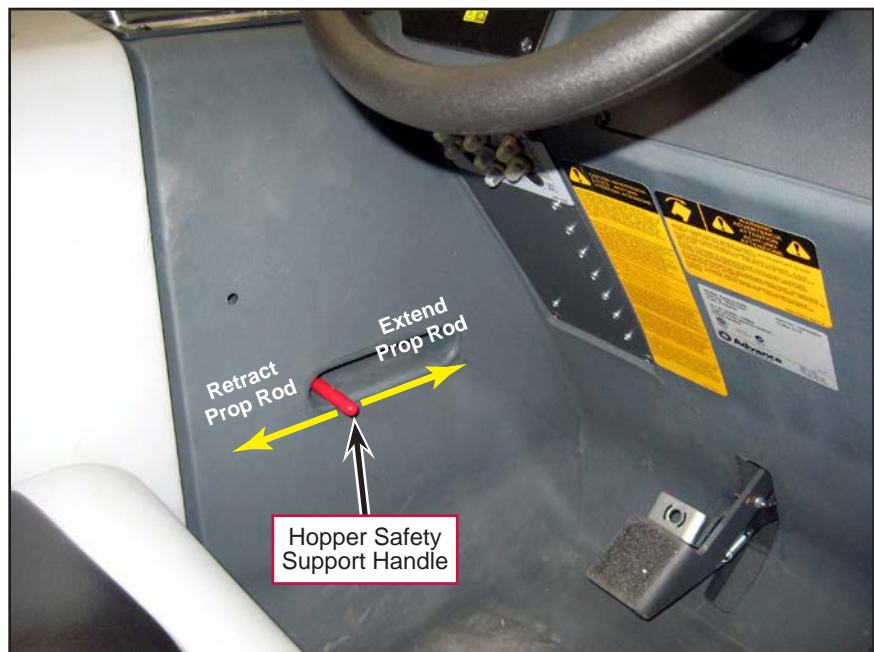

Hopper Door Cylinder

The **Hopper Door Cylinder** is attached to the **Hopper Door** and **Hopper Lift Arm Weldment**, and retracts and extends to open and close the **Hopper Door**.

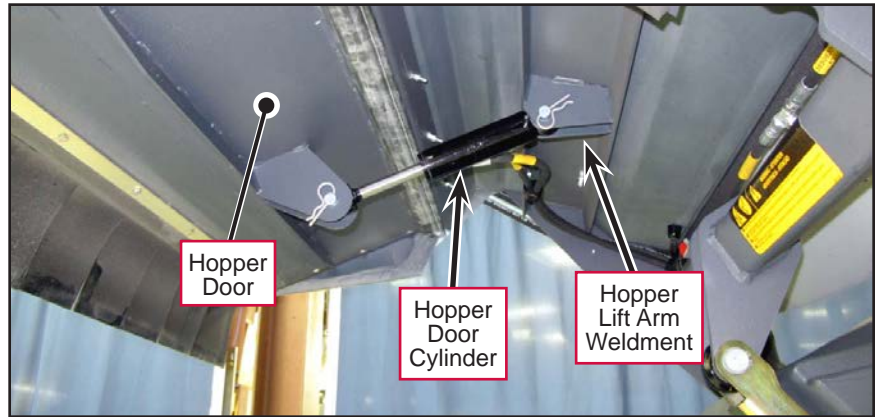

Hydraulic Manifold Assembly and Solenoid Valves

The **Hydraulic Manifold Assembly** is mounted on the frame underneath the center cover assembly/DustGuard™ tank.

- The **S5 Hopper Up/Down**, **S7 Hopper Open** and **S9 Hopper Lower** solenoid valves are mounted on the top of the **Hydraulic Manifold Assembly**.
- The **S6 Hopper Up Bypass** and **S1 Hopper Close/Open** solenoid valves are mounted on the bottom of the **Hydraulic Manifold Assembly**.

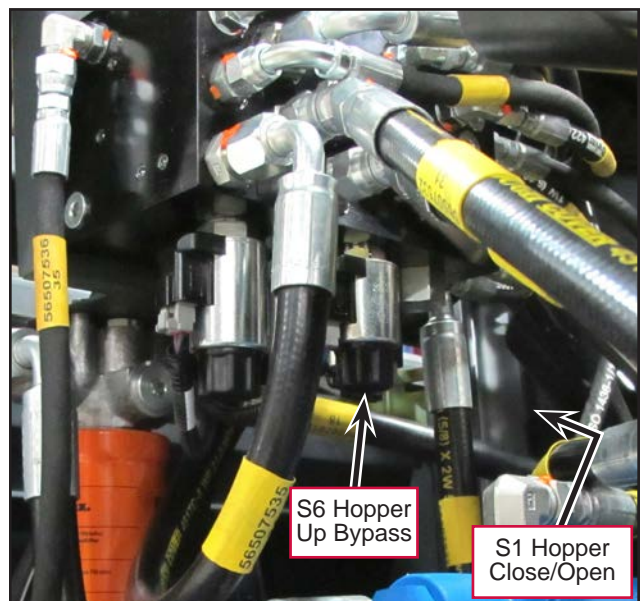
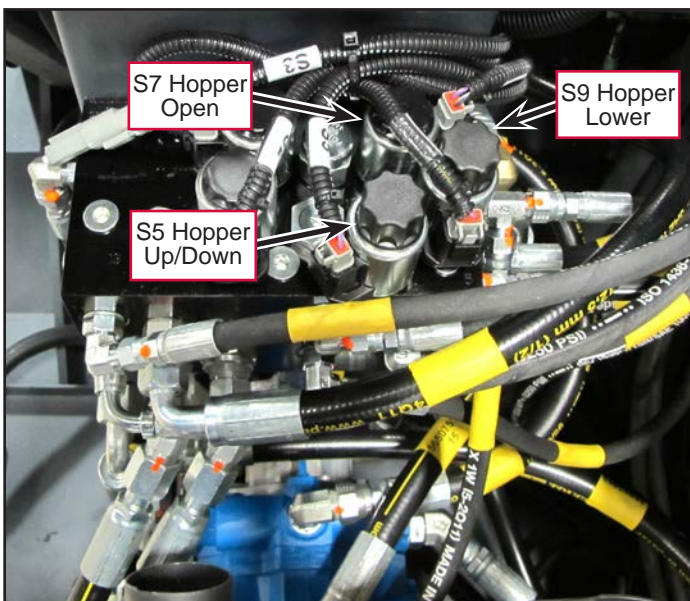
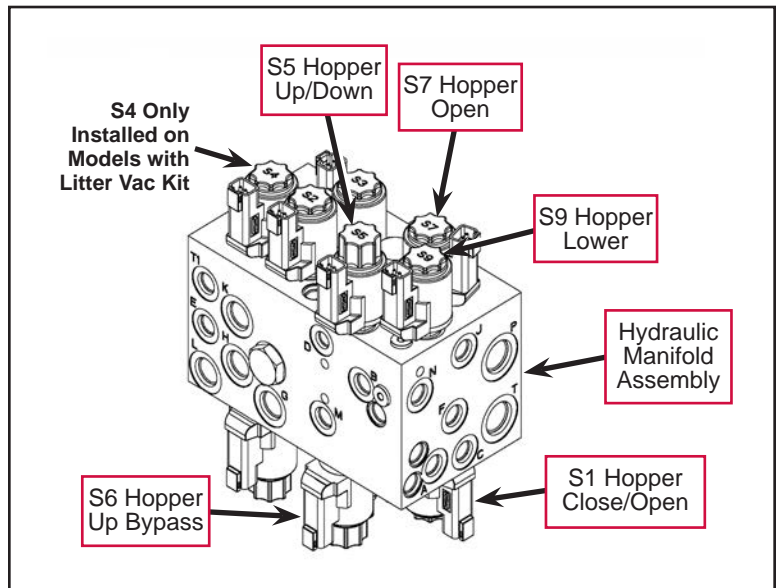

Troubleshooting

Problem	Cause	Correction
The hopper doesn't rise when the Raise Hopper Switch is pressed.	The engine is at idle speed.	Switch the engine to high speed.
	The Raise Hopper Switch is not making connection with the A2 Main Machine Controller.	Check the connection between the touch pad switch panel and pin J3-6 on the A2 Main Machine Controller. If the connection is OK, there may be a problem with the touch pad switch panel or the A2 Main Machine Controller.
	There is no power to the S5 Hopper Up/Down solenoid valve.	Check the wiring to the S5 Hopper Up/Down solenoid valve. The solenoid receives positive battery voltage and is grounded to the A2 Main Machine Controller when the Raise Hopper Switch is pressed. Repair/replace the wiring as necessary.
	The S5 Hopper Up/Down solenoid valve is not operating.	<ul style="list-style-type: none"> • Check the solenoid coil resistance. If the resistance doesn't measure approximately 9 ohms $\pm 10\%$, replace the coil. • Check the function of the solenoid valve cartridge. Replace as necessary.
	There is no power to the S6 Hopper Up Bypass solenoid valve.	Check the wiring to the S6 Hopper Up Bypass solenoid valve. The solenoid receives positive battery voltage and is grounded to the A2 Main Machine Controller when the Raise Hopper Switch is pressed. Repair/replace the wiring as necessary.
	The S6 Hopper Up Bypass solenoid valve is not operating.	<ul style="list-style-type: none"> • Check the solenoid coil resistance. If the resistance doesn't measure approximately 9 ohms $\pm 10\%$, replace the coil. • Check the function of the solenoid valve cartridge. Replace as necessary.
	The S9 Hopper Lower solenoid valve is stuck open.	Check the function of the solenoid valve cartridge. Replace as necessary.
	The S2 Main Broom solenoid valve is stuck open.	
The hopper mount or hopper lift cylinder is binding.	Check for any mechanical binding or damage to the hopper pivot points, hopper lift cylinder and cylinder mounting points. Correct as necessary.	

Problem	Cause	Correction
The hopper doesn't lower when the Lower Hopper Switch is pressed.	The engine is at idle speed.	Switch the engine to high speed.
	The Lower Hopper Switch is not making connection with the A2 Main Machine Controller.	Check the connection between the touch pad switch panel and pin J3-8 on the A2 Main Machine Controller. If the connection is OK, there may be a problem with the touch pad switch panel or the A2 Main Machine Controller.
	There is no power to the S9 Hopper Lower solenoid valve.	Check the wiring to the S9 Hopper Lower solenoid valve. The solenoid receives positive battery voltage and is grounded to the A2 Main Machine Controller when the Lower Hopper Switch is pressed. Repair/replace the wiring as necessary.
	The S9 Hopper Lower solenoid valve is not operating.	<ul style="list-style-type: none"> • Check the solenoid coil resistance. If the resistance doesn't measure approximately 9 ohms $\pm 10\%$, replace the coil. • Check the function of the solenoid valve cartridge. Replace as necessary.
	The S2 Main Broom solenoid valve is stuck open.	Check the function of the solenoid valve cartridge. Replace as necessary.
	The S6 Hopper Up Bypass solenoid valve is stuck closed.	
	The S5 Hopper Up/Down solenoid valve is stuck open.	
The hopper door doesn't open when the Open Dump Door Switch is pressed.	The Open Dump Door Switch is not making connection with the A2 Main Machine Controller.	Check the connection between the touch pad switch panel and pin J3-5 on the A2 Main Machine Controller. If the connection is OK, there may be a problem with the touch pad switch panel or the A2 Main Machine Controller.
	There is no power to the S7 Hopper Open solenoid valve.	Check the wiring to the S7 Hopper Open solenoid valve. The solenoid receives positive battery voltage and is grounded to the A2 Main Machine Controller when the Lower Hopper Switch is pressed. Repair/replace the wiring as necessary.
	The S7 Hopper Open solenoid valve is not operating.	<ul style="list-style-type: none"> • Check the solenoid coil resistance. If the resistance doesn't measure approximately 9 ohms $\pm 10\%$, replace the coil. • Check the function of the solenoid valve cartridge. Replace as necessary.
	There is binding in the hopper door mount or hopper door cylinder.	Check for any mechanical binding or damage to the hopper door pivot points, hopper door cylinder and cylinder mounting points. Correct as necessary.

Problem	Cause	Correction
The hopper door doesn't close when the Close Dump Door Switch is pressed.	The Close Dump Door Switch is not making connection with the A2 Main Machine Controller.	Check the connection between the touch pad switch panel and pin J3-7 on the A2 Main Machine Controller. If the connection is OK, there may be a problem with the touch pad switch panel or the A2 Main Machine Controller.
	There is no power to the S1 Hopper Close/Open solenoid valve.	Check the wiring to the S1 Hopper Close/Open solenoid valve. The solenoid receives positive battery voltage and is grounded to the A2 Main Machine Controller when the Lower Hopper Switch is pressed. Repair/replace the wiring as necessary.
	The S1 Hopper Close/Open solenoid valve is not operating.	<ul style="list-style-type: none"> • Check the solenoid coil resistance. If the resistance doesn't measure approximately 9 ohms $\pm 10\%$, replace the coil. • Check the function of the solenoid valve cartridge. Replace as necessary.
	The S7 Hopper Open solenoid valve is stuck in the energized position.	Check the function of the solenoid valve cartridge. Replace as necessary.
	There is dirt or debris preventing the hopper door from closing.	<ul style="list-style-type: none"> • Clean/remove any dirt or debris from the hopper door and door sealing surfaces.
	There is binding in the hopper door mount or hopper door cylinder.	Check for any mechanical binding or damage to the hopper door pivot points, hopper door cylinder and cylinder mounting points. Correct as necessary.

Specifications

Component	Specifications
S1, S5, S6, S7 and S9 Solenoid Valves	Nominal Coil Resistance – 8 Ohms
Hopper Lift Cylinder	Bore Diameter – 2.5 in.
	Rod Diameter – 1.25 in.
Hopper Door Cylinder	Bore Diameter – 1.5 in.
	Rod Diameter – .75 in.

Hydraulic System

Functional Description

Overview

The hydraulic **Piston Pump** powers the traction **Drive Motor**. The hydraulic **Gear Pump** powers the **Main Broom Motor**, **Side Broom Motor(s)** and the **Dust Control Vacuum Fan Motor**. The **Gear Pump** also powers the **Hopper Lift**, **Hopper Door** and **Side Broom Cylinders**, and the **Steering Control Unit** and **Steering Cylinder**.

The **Piston Pump** and traction **Drive Motor** are a “closed” system. Electrically-controlled solenoid valves, located in the **Hydraulic Manifold Assembly**, direct the hydraulic oil from the **Gear Pump** to the various system components to perform the sweeping and dust control functions, raise and lower the hopper, and open and close the hopper door. The hydraulic oil from the machine system components returns through the **Oil Cooler** and **Oil Filter** to the **Reservoir**.



Note: The individual hydraulic motors and cylinders are described in the corresponding machine system sections.

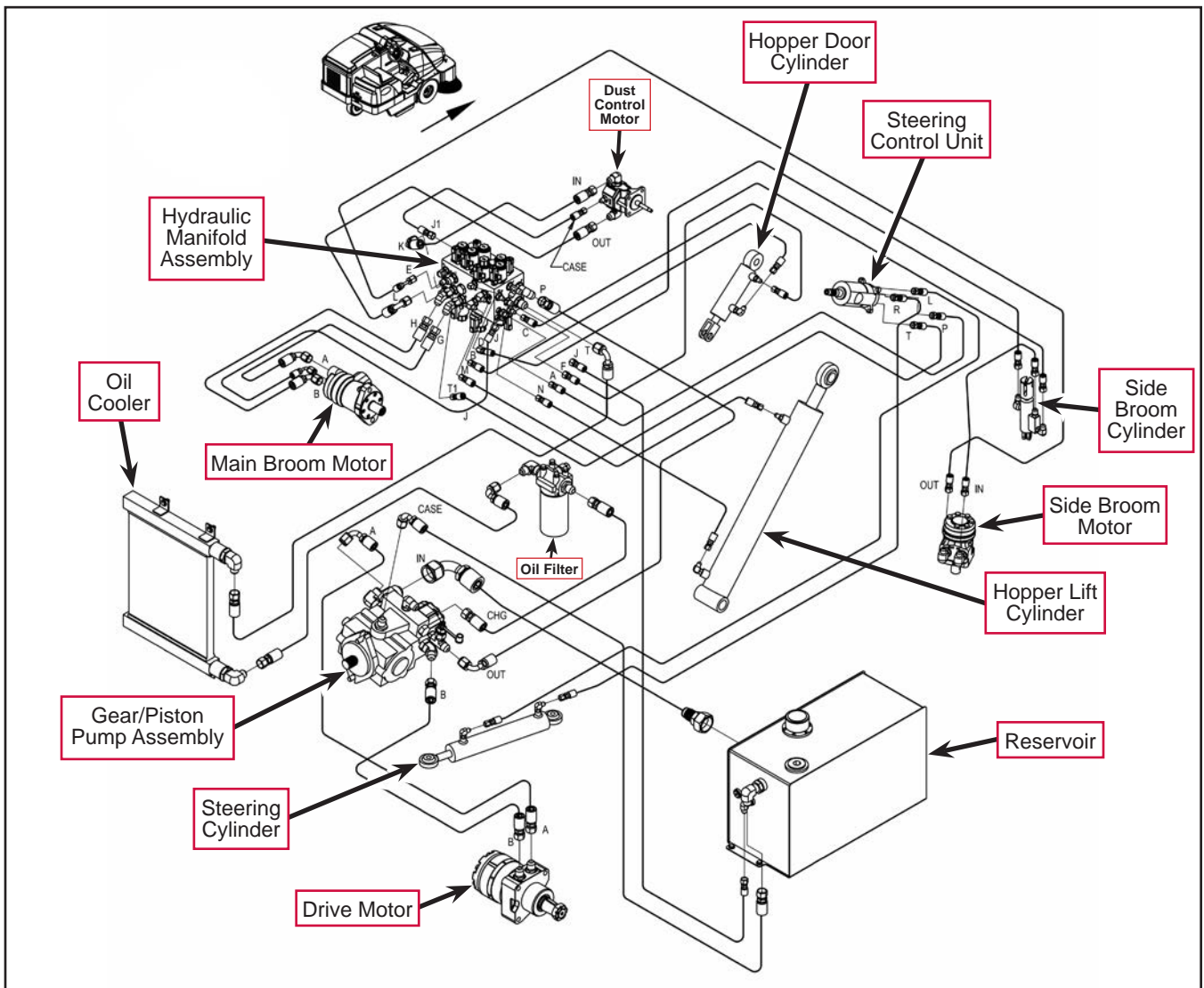

Hydraulic Pumps

The engine drives the two hydraulic pumps that power the drive wheel and the various system components:

The **Piston Pump** (2.48 CIR) is a variable-displacement axial piston pump that powers the drive motor.

The **Gear Pump** (1.02 CIR) powers the main and side broom motors, dust control vacuum fan motor, hopper lift cylinder, hopper door cylinder, side broom cylinder, steering control unit and steering cylinder,

The **Test Port** is located on the pressure side of the **Gear Pump** to allow you to measure the pressure from the **Gear Pump**.

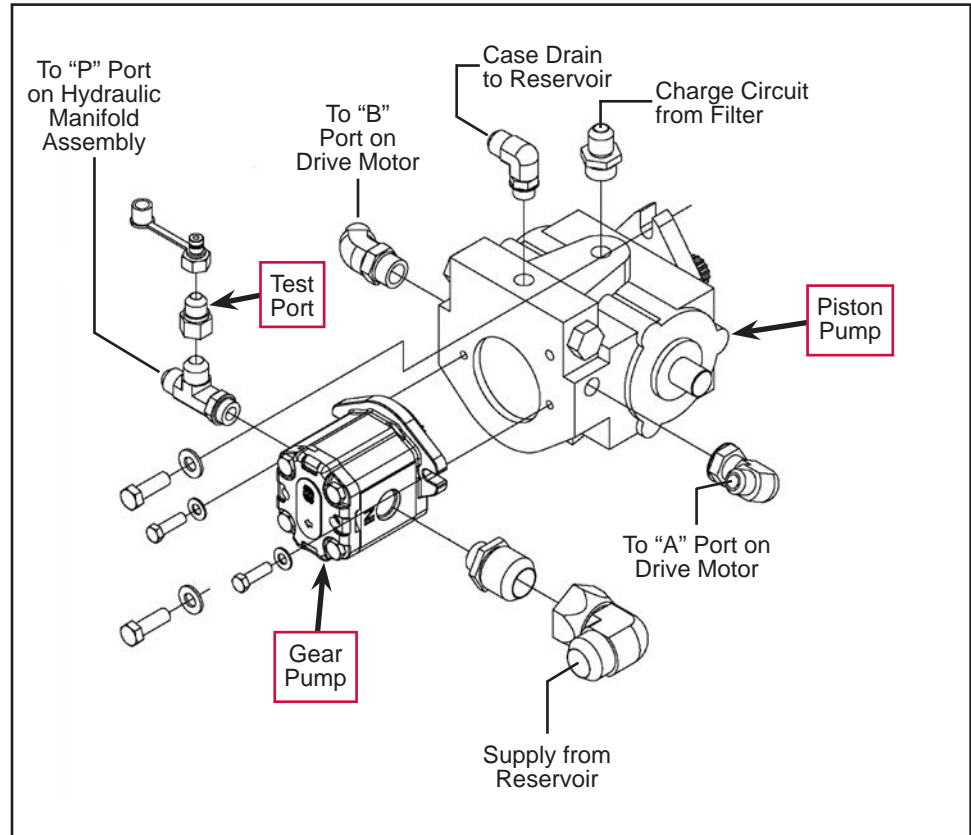

Hydraulic Manifold Assembly

The **Hydraulic Manifold Assembly** contains the hydraulic solenoid valves that control the oil flow to the main broom motor, side broom motor(s), dust control motor, hopper lift cylinder, hopper door cylinder, side broom lift cylinder and steering control unit.

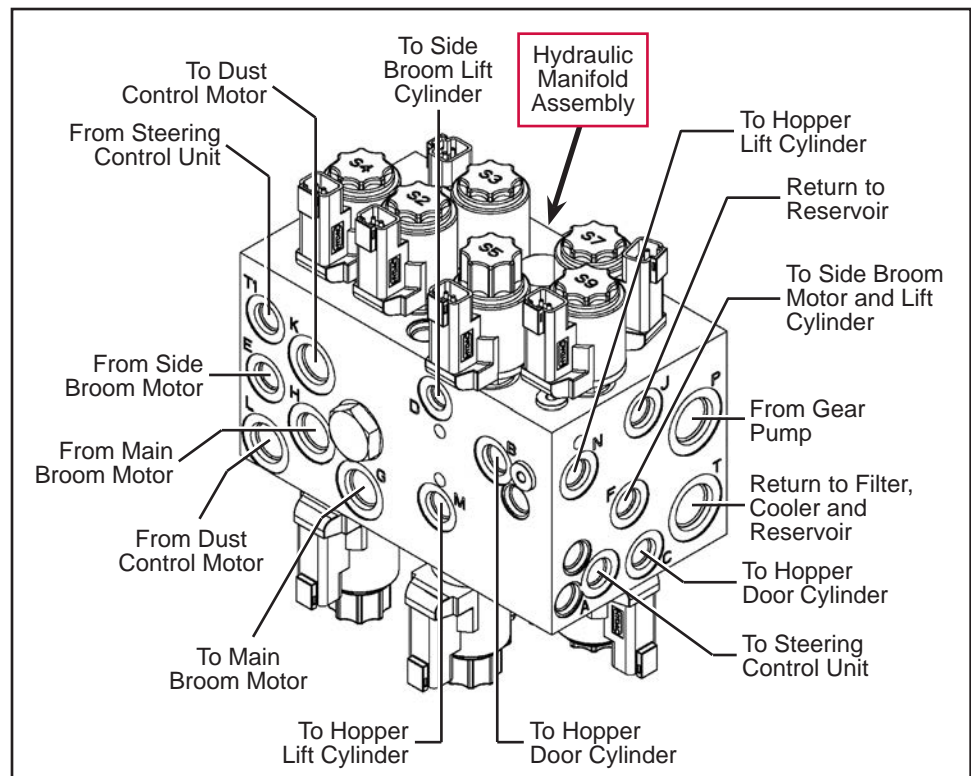

Electrical Schematic

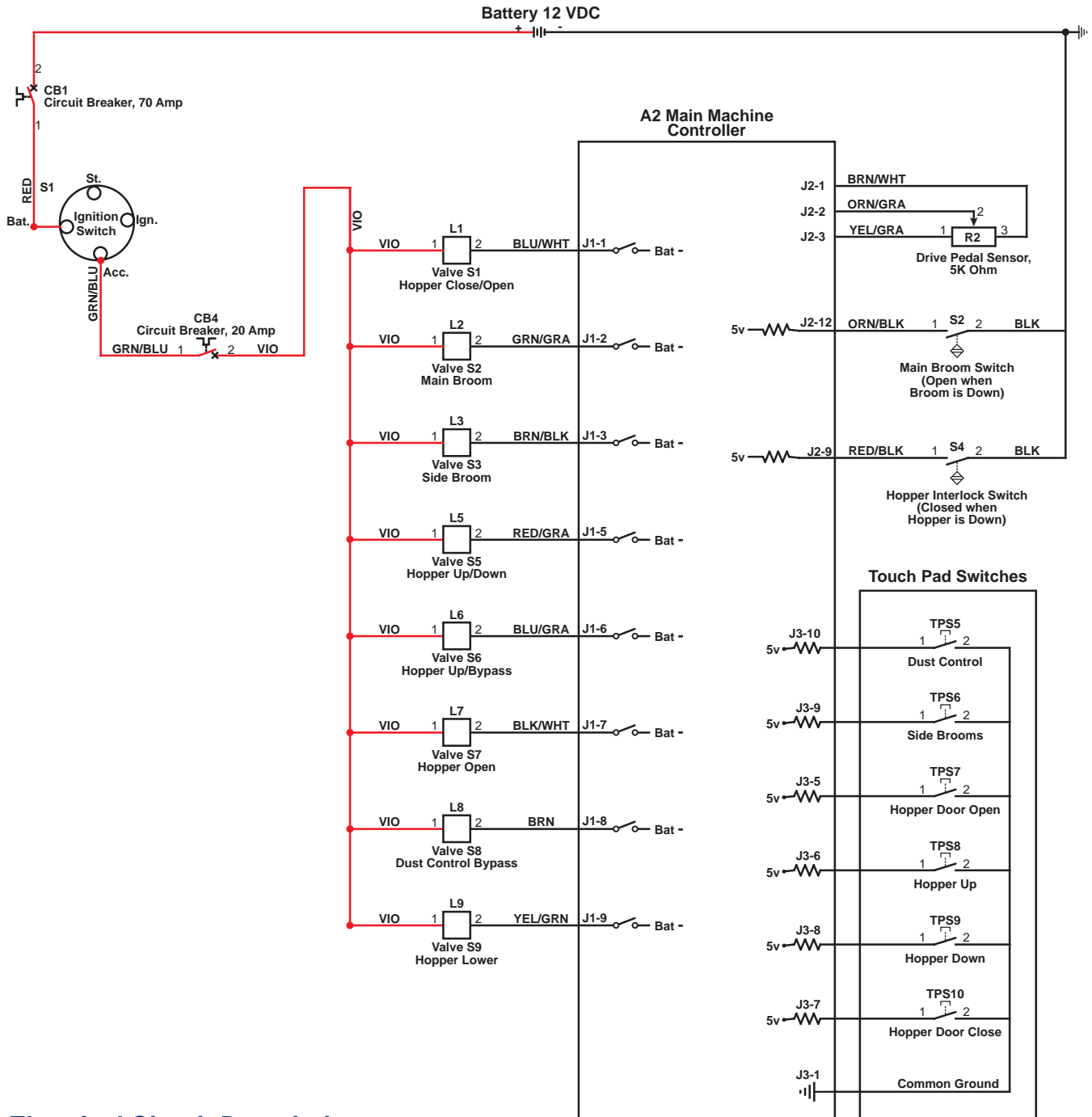

Electrical Circuit Description

The **Touch Pad Switches** on the control panel enable the solenoid **Valves** corresponding to the selected functions.

The **A2 Main Machine Controller** will actuate the appropriate solenoid **Valves** to run the main broom, side broom and dust control motors, and extend the side broom cylinder when the following conditions are met:

- The main broom is lowered and the **Main Broom Switch S2** is open.
- The hopper is down and the **Hopper Interlock Switch S4** is closed.
- The drive pedal is moved from neutral, changing the resistance through the **5K Ohm Drive Pedal Sensor** from its “deadband” range.

Component Locations

The following components are included in this section:

- Hydraulic Piston and Gear Pumps
- Hydraulic Manifold Assembly
- Hydraulic Oil Reservoir
- Oil Filter
- Oil Cooler

Hydraulic Piston and Gear Pumps

The hydraulic **Piston Pump** and **Gear Pump** are mounted on the rear of the engine (toward the front of the machine) and are driven by the engine crankshaft.

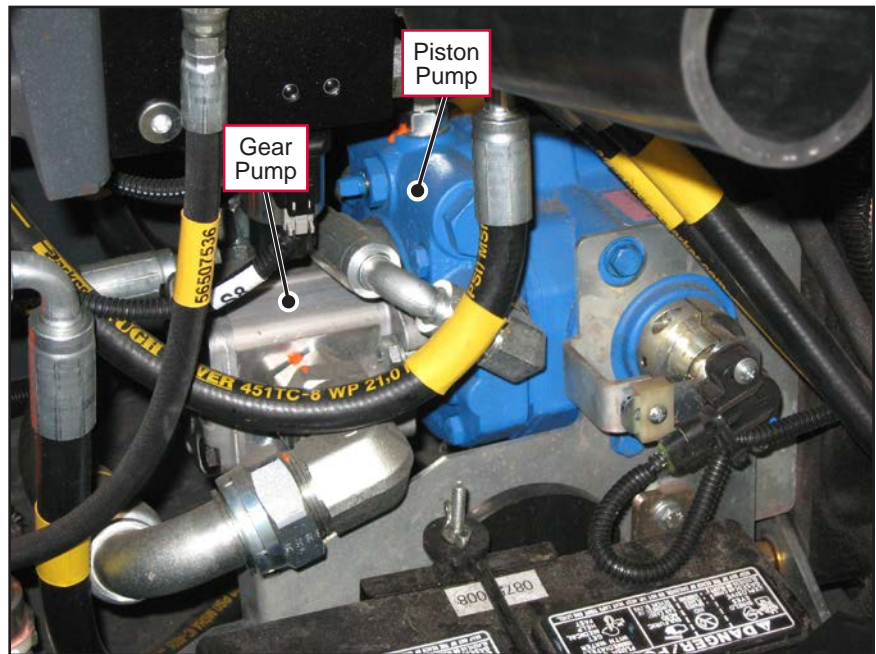

Hydraulic Manifold Assembly

The **Hydraulic Manifold Assembly** is mounted on the frame underneath the center cover assembly/ DustGuard™ tank (removed in the adjacent photo).

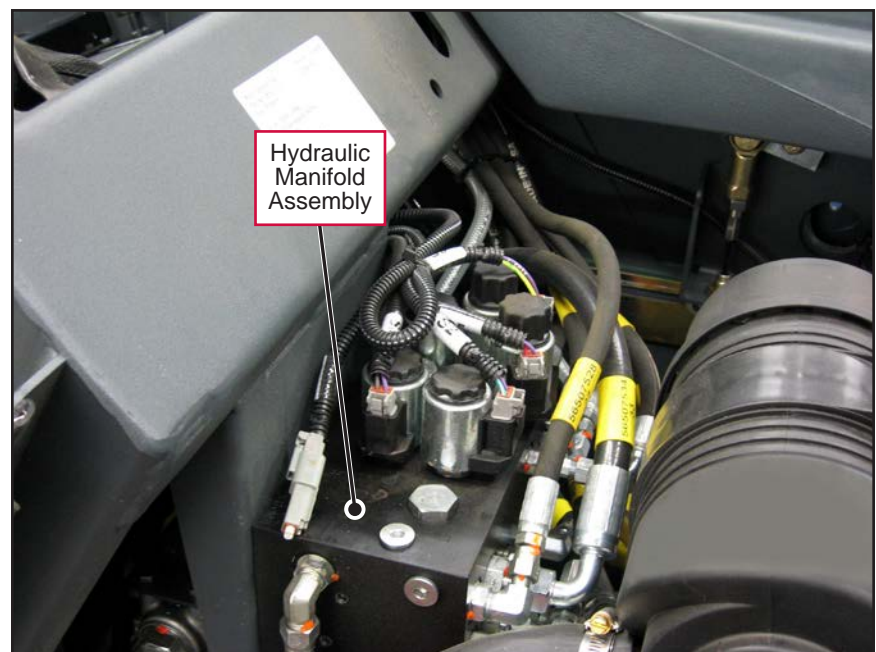

Hydraulic Oil Reservoir

The **Hydraulic Oil Reservoir** is located below the Operator seat. The hydraulic oil in the **Hydraulic Oil Reservoir** is at the correct level when it is halfway up the filter screen inside the reservoir filler neck as viewed when the **Filler Cap** is removed.

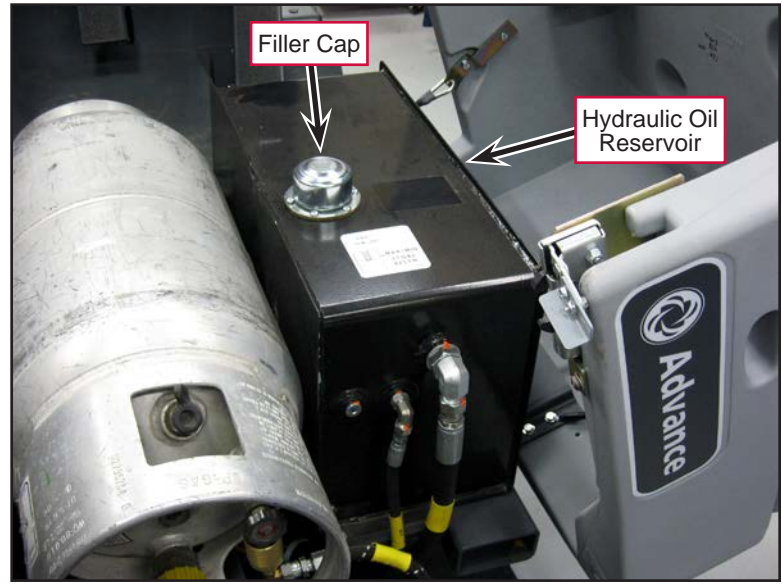

Oil Filter

The **Oil Filter** is mounted to the machine frame and filters the oil returning to the reservoir.

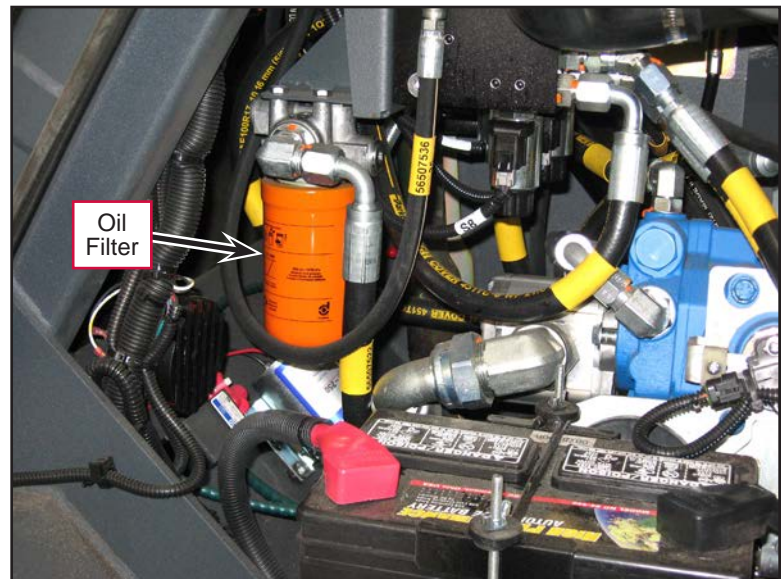

Oil Cooler

The **Oil Cooler** is mounted to the rear of the engine **Radiator**.

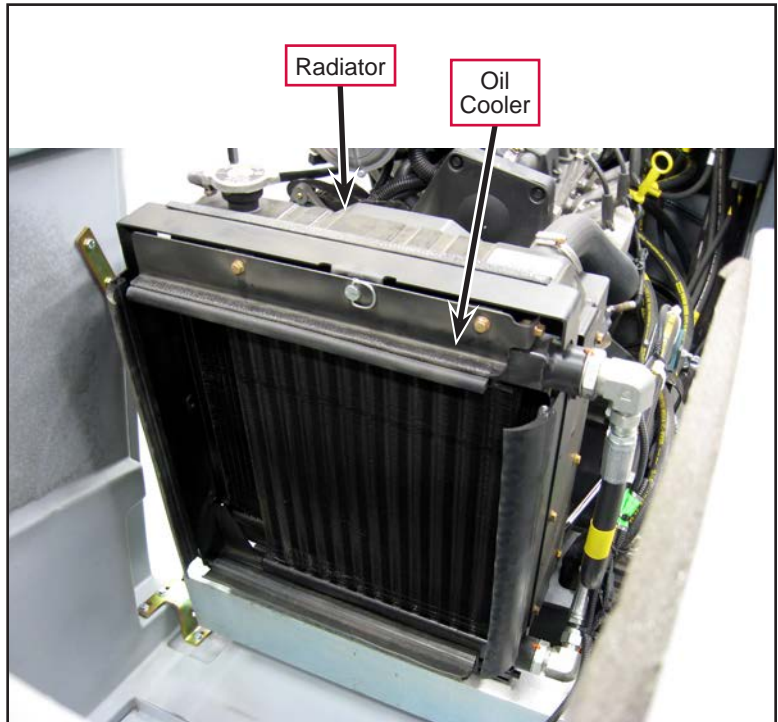

Maintenance and Adjustments



Warning! Before performing any machine maintenance or adjustments, make sure the key switch is off, the key is removed from the machine and the parking brake is engaged.

To Check the Hydraulic Oil Level

Remove the filler cap from the reservoir and check the hydraulic oil level in the reservoir. The hydraulic oil level should be halfway up the **Filter Screen** inside the reservoir filler neck. Add 10w-30 oil as needed.



Note: Change and flush the oil if major contamination from a mechanical failure occurs.

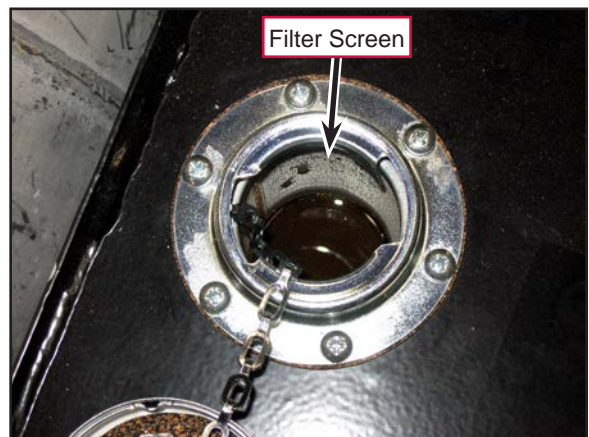

To Change the Hydraulic Oil Filter



Caution! Make sure the hydraulic system is not under pressure, and that the hydraulic filter and reservoir are cool to the touch before servicing the filter.

Make sure you are wearing the appropriate clothing and eye protection when working with or near the hydraulic system.

1. It's recommended that you lay down some rags or paper towels underneath the **Oil Filter** to catch any oil that may spill.
2. Spin the **Oil Filter Cartridge** off of the **Oil Filter Head**.
3. Install the new **Oil Filter Cartridge** onto the **Oil Filter Head**.

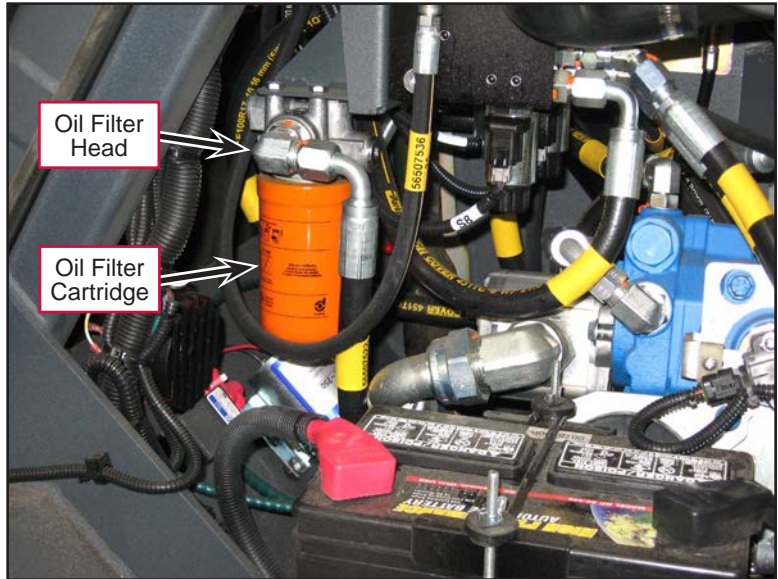

To Clean the Hydraulic Oil Cooler

Clean the engine radiator and hydraulic oil cooler every 30 hours of operation as follows:



Caution! Wear Safety glasses when cleaning the engine radiator and hydraulic oil cooler.

1. Tip the **Engine Cover** back, then disconnect the cable latch on the left side of **Engine Cover** to allow the **Cover** to tip all the way back and out of the way.
2. Turn the locking mechanism at the top of the **Hydraulic Oil Cooler** to allow the **Cooler** to tip back away from the **Radiator** for easy access.
3. Blow out the **Radiator** and **Hydraulic Oil Cooler** with compressed air, or clean using low-pressure water to rinse any debris from the fins.

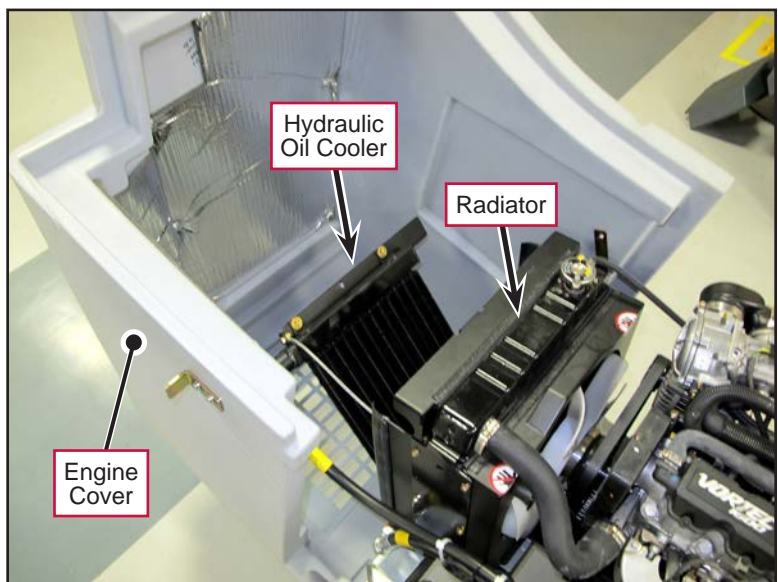



Caution! Do not use a pressure washer or a mechanical brush to clean fins since this can damage the fins. If the fins get bent, carefully straighten them to improve cooling performance.

4. Lift the **Hydraulic Oil Cooler** to its upright position and latch it into place.
5. Lift the **Engine Cover** up and reconnect the cable latch.

Troubleshooting

General Troubleshooting

Problem	Cause	Correction
General poor hydraulic performance.	Low oil hydraulic level.	Check the oil level in the reservoir and add oil as necessary.
	Hydraulic oil temperature too high.	<ul style="list-style-type: none"> • Check for any restrictions to or from the oil cooler and correct as necessary. • Clean the cooling fins on the oil cooler to ensure adequate airflow through the cooler.
	Hydraulic oil filter plugged.	Replace the oil filter cartridge.
	Gear pump failing.	Check the output pressure from the gear pump. If below specs, repair or replace the pump.
	Contamination in the hydraulic system.	Drain, flush and refill the system.

General Information Regarding Checking Hydraulic Pressures

Accurate measurements are the key to troubleshooting a hydraulic system. Once you obtain accurate measurements you can compare them to the specifications to analyze a problem.

You can use digital tachometers, flow gauges/meters or pressure gauges to troubleshoot the hydraulic system. The pressure gauge should have a range of 0 to 3000 psi (see the **Special Tools** section). The flow meter must be rated to 3000 psi and 10 gal./min.

The most convenient way to check for oil flow is to check the RPM of the motor that is performing poorly. Refer to the following tables to determine the motor RPM. If the motor speed is correct, the pump is producing the correct amount of oil flow. However, this does not mean that if a motor is running too slow the problem is in the pump.

The following information should be used to check for correct system pressure. The readings are nominal measured figures, and there will be variations due to manufacturing tolerances and system oil temperature. If any reading varies greater than 20 percent, there will be a noticeable loss of performance and the problem should be corrected.

Checking the Gear Pump Pressure



Note: There is **Test Port** on the **Gear Pump** that can be used to check the **Gear Pump** pressure.

1. Connect the pressure gauge to the **Test Port** on the **Gear Pump**.
2. Run the engine in the high throttle position and allow the hydraulic oil to warm up.
3. Refer to the following tables to determine if the gear pump and/or hydraulic motor is operating correctly.



Note: All of the following readings were static, taken on a smooth painted concrete surface.

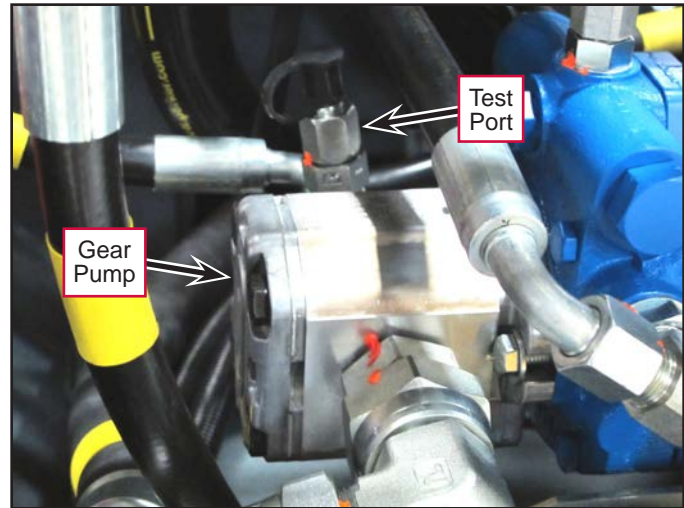

Machine Condition	Measured Pressure at the Gear Pump Test Port
High RPM, nothing running	380 psi
High RPM, main broom only running, standard broom, two-inch wide brush pattern on concrete, vacuum fan turned off	1,275 psi
High RPM, main broom off, vacuum fan turned on, side brooms off	1,650 psi
High RPM, main broom on, two-inch wide brush pattern on concrete, vacuum fan turned on, side brooms off	1,770 psi
High RPM, main broom on, two-inch wide brush pattern on concrete, vacuum fan turned on, side brooms on	1,810 psi
High RPM, raising empty hopper Time to raise hopper – 10/11 seconds	2,875 psi
High RPM, lowering empty hopper Time to lower hopper – 7 seconds	380 psi
High RPM, opening hopper door, nothing else running	20 psi
High RPM, closing hopper door, nothing else running	50 psi
Two side brooms running, nothing else running	360 psi
One side broom running, nothing else running	425 psi

Machine Condition	Measured Motor Speed
Two side brooms on the floor	103 RPM
One side broom on the floor	130 RPM
Main broom with a two-inch pattern	405 RPM
Vacuum fan impeller	8,920 RPM

Checking the Piston Pump Pressure



Note: Checking the piston pump hydraulic pressure will require you to assemble the appropriate fittings that will allow you to connect your pressure gauge to a suitable location.

Machine Condition	Measured Pressure from the Piston Pump
Level surface, 70°F ambient temperature, empty hopper and tank.	Pedal fully depressed – 700 psi
	Pedal 1/2 depressed – 600 psi

Hydraulic Truth Table

Electrical Solenoid's Energized Status									
Solenoid Function	S1	S2	S3	S4	S5	S6	S7	S8	S9
Hopper Raise (UP)					X	X			
Hopper Lower (DN)									X
Dump Door Open	X								
Dump Door Closed							X		
Main Broom State ON		X				X			
Main/Side Broom State ON		X	X			X			
Dust Control ON Wand State (**)				X		X			
Dust Control OFF Bypass (*)								X	
Side Broom Lower			X						
Side Broom Raise & Turn OFF Side Broom Motor			0V						
No Hydraulic Manifold Functions	System overload in relief					S6 not energized (***)			

* Operator sweeping wet debris with the dust control fan (impeller) turned off.

** Operator using vacuum wand option. The dust control fan operates when the machine's drive is stationary. To vacuum, attach the suction hose wand to the special hopper inlet fitting.

*** The S6 solenoid valve assembly bypasses the sweep system components and sends its hydraulic oil flow to the tank when S6 is de-energized (0 volts).

Specifications

General Specifications

Component	Specifications	
System Capacity	11 gal. (41.6 L)	
Fluid Type	SAE 10w-30 motor oil	
Piston Pump	Type – manually-variable displacement piston pump, tow valve included	
	Displacement – 0 to 2.48 CIR	
	Speed – 3600 RPM max.	
	Continuous pressure – 3000 psi [206.8 bar]	
	Maximum pressure – 5000 psi [344.7 bar]	
	Main Loop Relief Valve Set Point – 3000 psi [206.8 bar]	
Gear Pump	Type – external spur gear, positive displacement	
	Displacement – 1.02 CIR	
Hydraulic Manifold Assembly	Solenoid Valves S1, S2, S3, S4, S5, S6, S7 and S9	Nominal Coil Resistance – 9 ohms (measured on one machine)
	Solenoid Valve S8	Nominal Coil Resistance – 6.5 ohms (measured on one machine)

Hydraulic Manifold Assembly

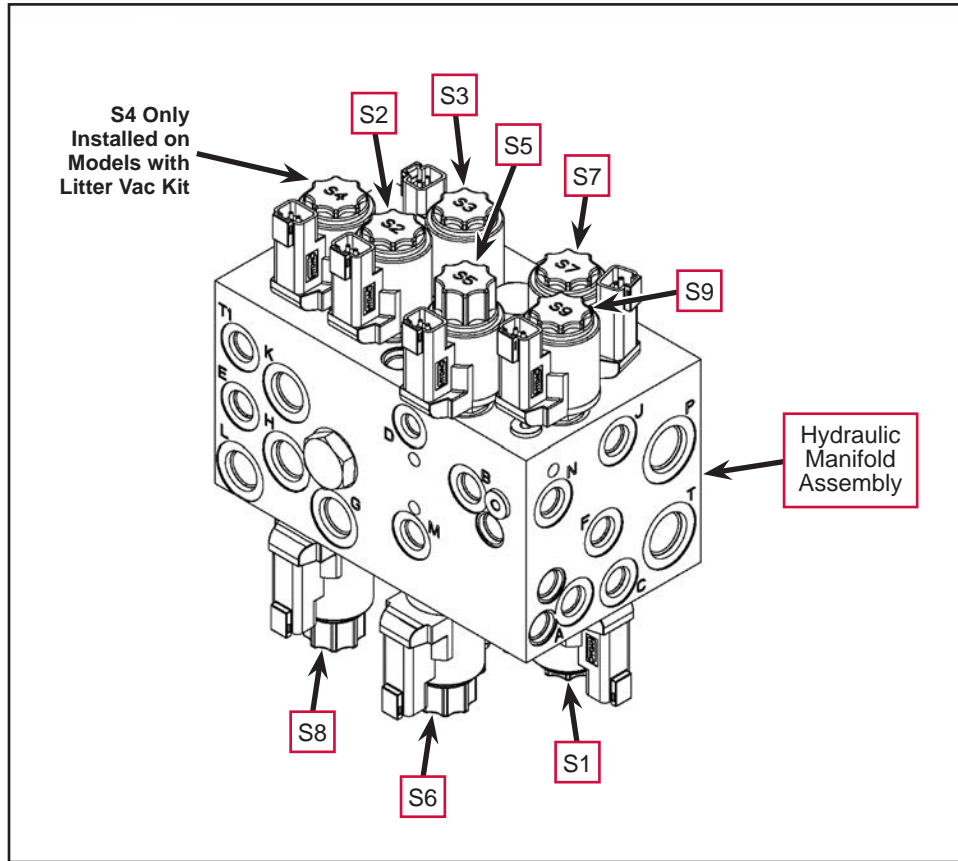

Solenoid Valve	Hydraulic Circuit Function	Component Description
S1	Hopper Close/Open	Solenoid-actuated, 2/2 directional poppet, pilot operated cartridge valve
S2	Main Broom	
S3	Side Broom	Solenoid-actuated 4/2 directional spool, direct acting cartridge valve
S7	Hopper Open	
S5	Hopper Up/Down	Solenoid-actuated 2/2 directional poppet, direct acting cartridge valve
S9	Lower Hopper	
S6	Hopper Up Bypass	Solenoid-actuated 2/2 directional poppet, pilot operated cartridge valve
S8	Dust Control Bypass	Solenoid-actuated 3/2 directional spool, direct acting cartridge valve
Coil	Used on S1-S7, S9	12 VDC; nominal coil resistance – 9 Ω.
Coil	Used on S8	12 VDC; nominal coil resistance – 6.5 Ω.





Note: The following solenoid valves are interchangeable:

- S1 and S2
- S3 and S7
- S5 and S9

Also note that S1, S2, S3, S5, S6, S7 and S9 all use the same solenoid coil.

Special Tools

<p>Hydraulic test gauge w/connector, 3000 PSI range, p/n 56504516</p>	
<p>Flow Meter – rated at 3000 psi and 10 gal./min. (typical shown)</p>	
<p>Various hydraulic fittings required to connect hydraulic test gauge into hydraulic circuits</p>	

Hydraulic Schematic, 56507055, Rev. N

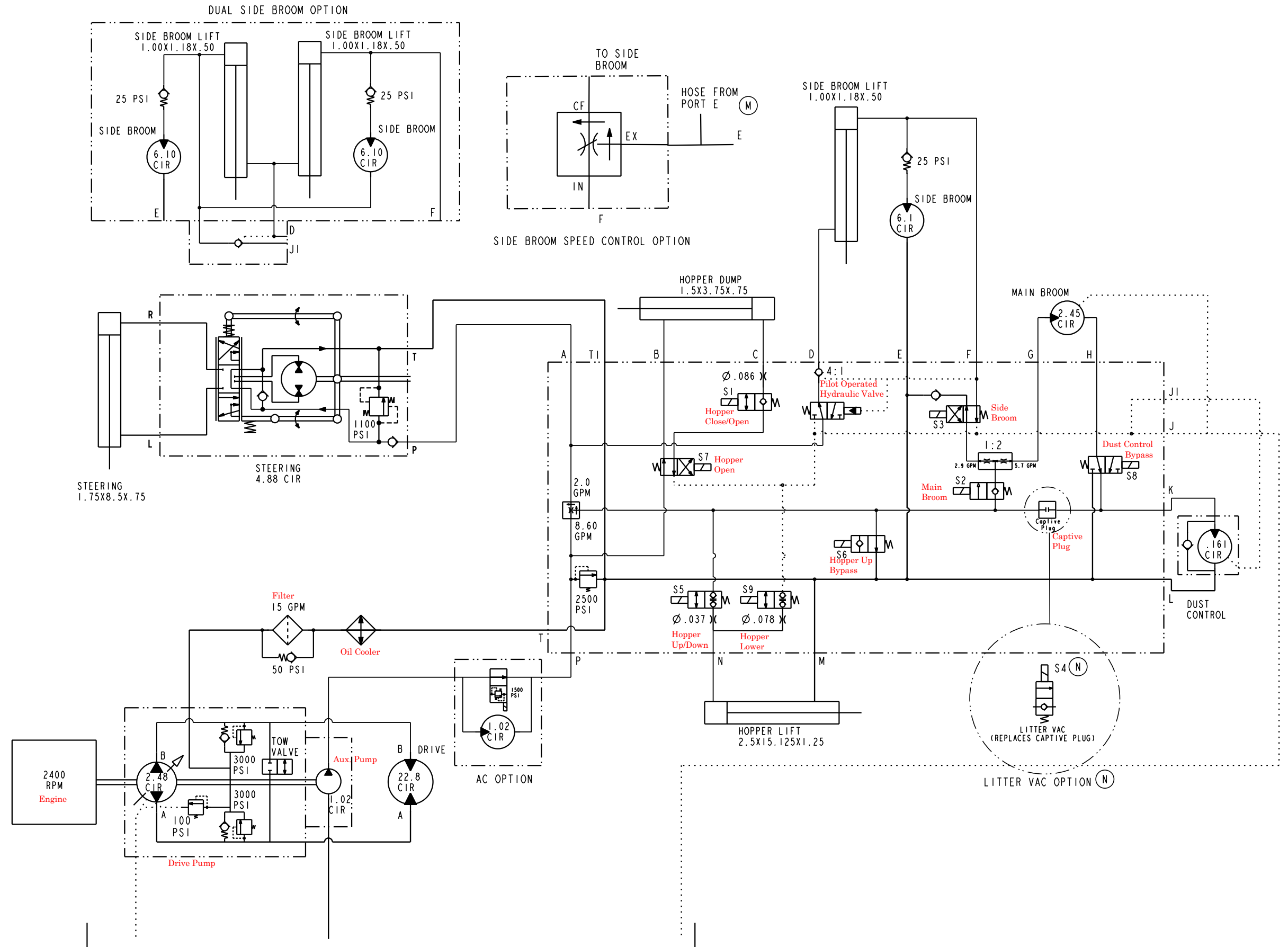

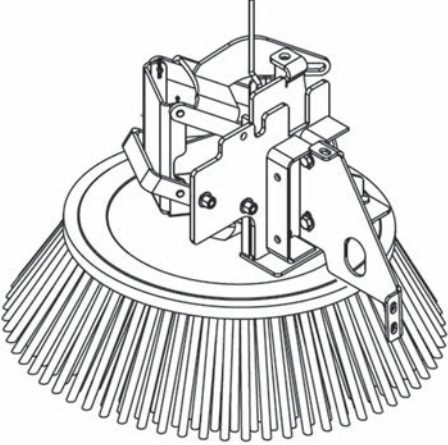
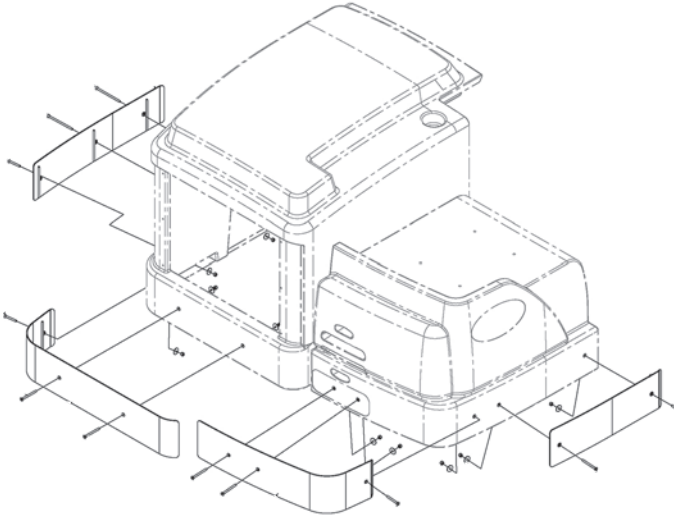
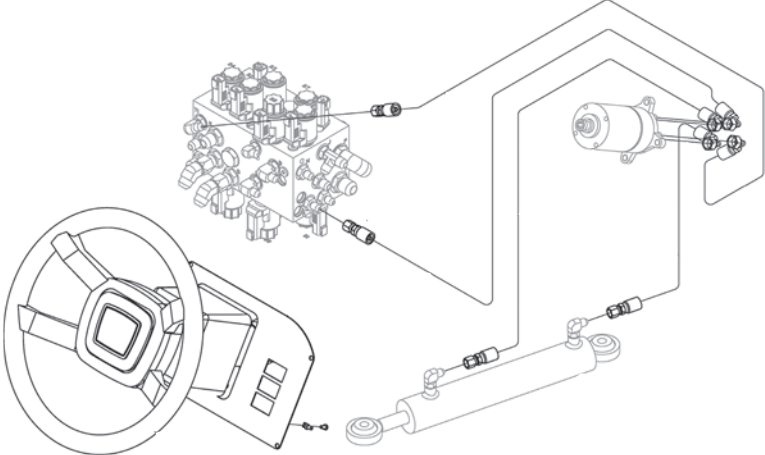

Options and Accessories

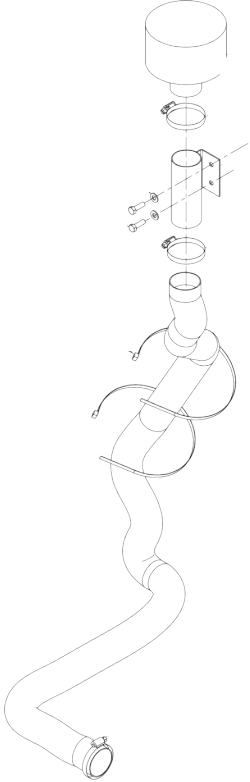
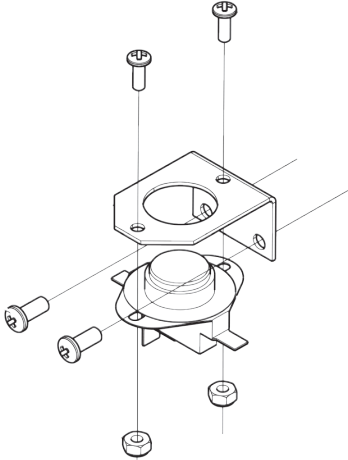
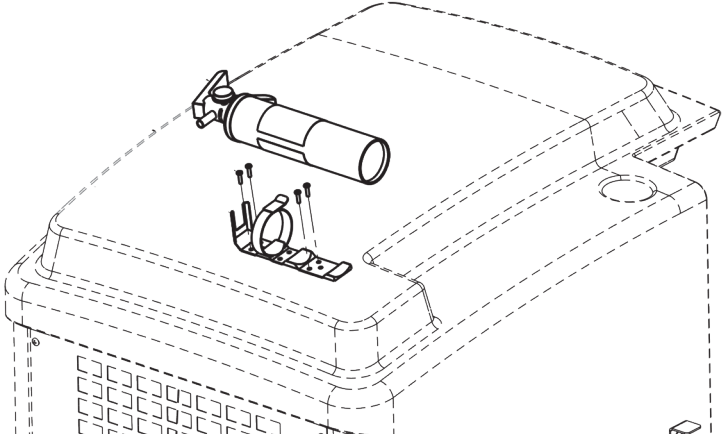
Description	Illustration
<p data-bbox="248 495 529 527">Left Hand Side Broom</p>	 A technical line drawing of a circular broom attachment. It features a central mounting bracket with a vertical rod extending upwards. The broom head is composed of numerous parallel bristles radiating from a circular base. The mounting bracket includes various adjustment points and a locking mechanism.
<p data-bbox="248 995 529 1058">Rear Bumper Kit (For Non-Cab models)</p>	 A technical line drawing showing the rear bumper kit assembly. It includes a main bumper bar, a central support structure, and side mounting brackets. Dashed lines indicate the assembly points and alignment of the components. The bumper is designed to be mounted to the rear of a vehicle chassis.
<p data-bbox="289 1524 488 1556">Tilt Steering Kit</p>	 A technical line drawing of a tilt steering kit. It shows a steering wheel mounted on a steering column. The kit includes a hydraulic cylinder, a control valve, and various hoses and fittings. The hydraulic cylinder is connected to the steering column, and the control valve is connected to the hydraulic system. The diagram illustrates the mechanical and hydraulic components of the tilt steering system.

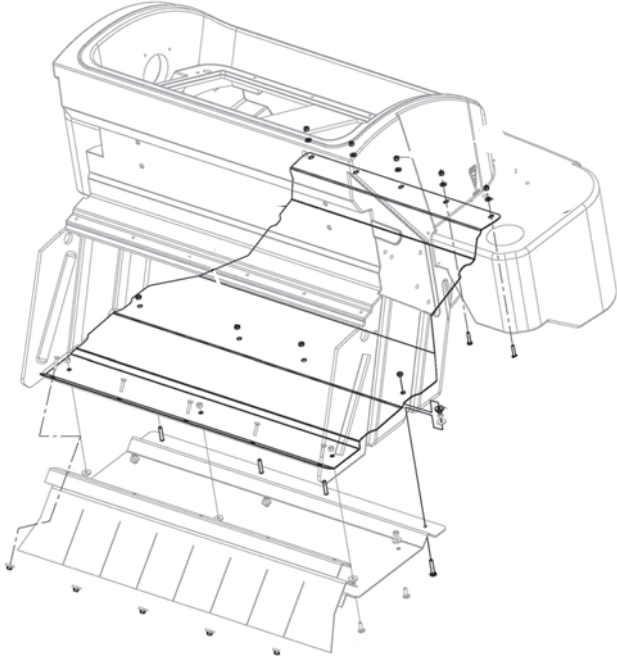
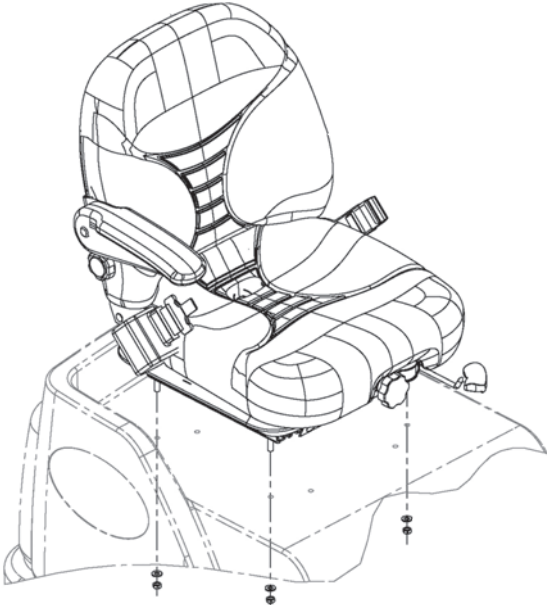
Description	Illustration
<p data-bbox="180 556 597 617">Raised Air Intake Kit for use with Overhead Guard</p>	
<p data-bbox="185 1218 592 1251">Hopper Temperature Sensor Kit</p>	
<p data-bbox="246 1675 531 1738">Fire Extinguisher Kit (For Non-Cab models)</p>	

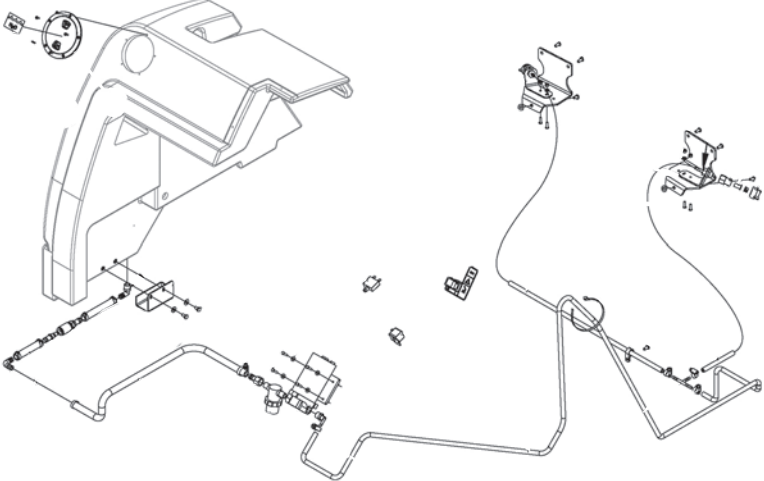
Description	Illustration
<p data-bbox="235 506 545 541">Hopper Bottom Plate Kit</p>	 A technical line drawing showing a hopper bottom plate kit installed on a machine. The kit consists of a large rectangular plate with several mounting points, which is being attached to the underside of the machine's hopper. The machine's frame and hopper are shown in a perspective view, with the plate being positioned below them. Various screws and brackets are indicated by small circles and lines, showing the assembly process.
<p data-bbox="256 1161 524 1197">Suspension Seat Kit</p>	 A technical line drawing showing a suspension seat kit installed on a machine. The seat is a high-back, bucket-style seat with a mesh-like backrest and a cushioned seat. It is being attached to the machine's frame using a suspension system. The suspension system includes a seat base, a seat back, and a seat cushion, all of which are connected to the machine's frame by a series of brackets and bolts. The machine's frame is shown in a perspective view, with the seat being positioned on top of it. Dashed lines indicate the mounting points and the suspension system's connection to the frame.

Description	Illustration
<p data-bbox="245 426 532 457">DustGuard Premist Kit</p>	 <p data-bbox="678 205 1437 682">An exploded view diagram of the DustGuard Premist Kit. It shows a large, curved dust guard component at the top left. Below it are various hoses, connectors, and mounting brackets. On the right side, there are two separate assemblies, each consisting of a bracket and a hose, likely for misting or cleaning purposes. The diagram uses small circles and lines to indicate the assembly points for the various parts.</p>
<p data-bbox="310 999 467 1031">Seat Belt Kit</p>	 <p data-bbox="824 724 1356 1312">A 3D perspective illustration of a grey, padded seat. A seat belt kit is shown installed on the seat. The kit includes a seat belt buckle, a retractor, and a shoulder strap. The retractor is mounted to the side of the seat, and the shoulder strap is attached to the seat's frame. The seat belt is shown buckled. The illustration uses lines to show the connection points between the seat belt components and the seat's structure.</p>

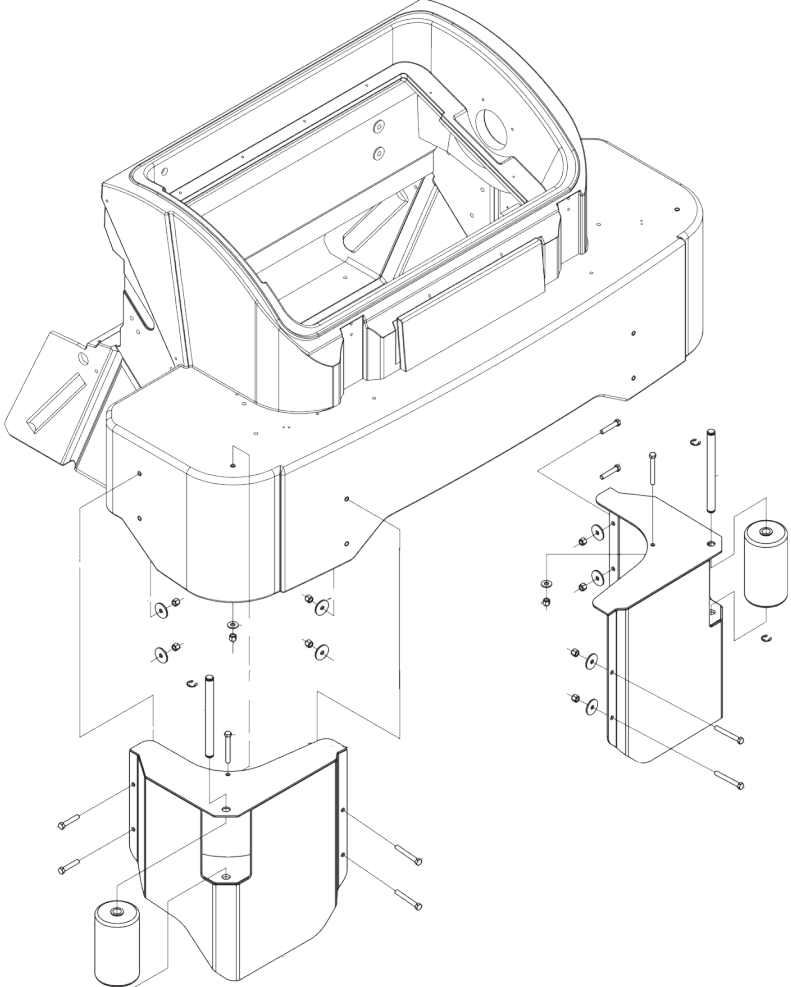
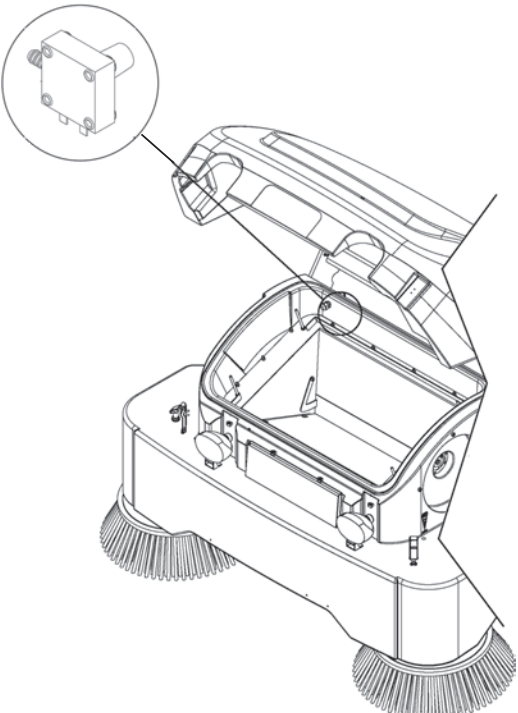
Description	Illustration
<p data-bbox="267 661 511 724">Right and Left Side Broom Guard Kits</p>	
<p data-bbox="235 1543 544 1585">Plugged Filter Switch Kit</p>	

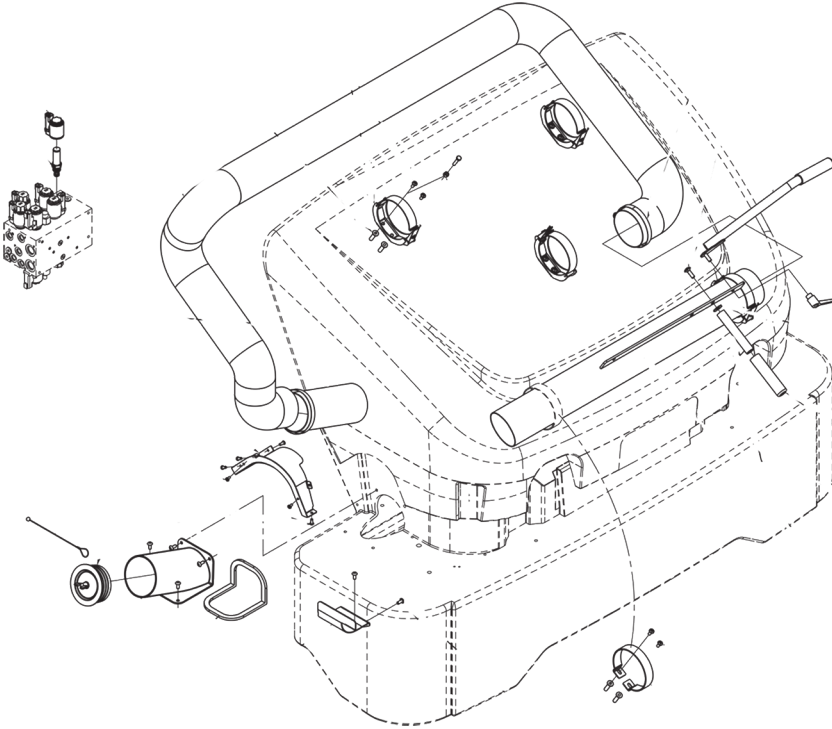
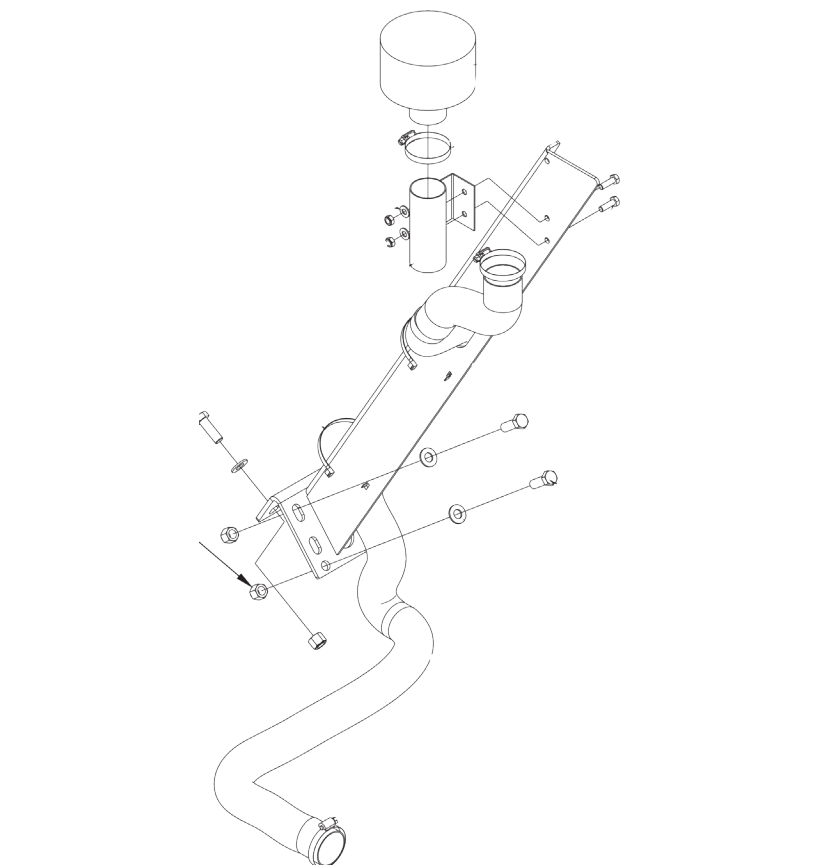
Description	Illustration
<p data-bbox="305 541 472 573">Litter Vac Kit</p>	
<p data-bbox="203 1339 574 1398">Raised Air Intake Kit, without Overhead Guard</p>	

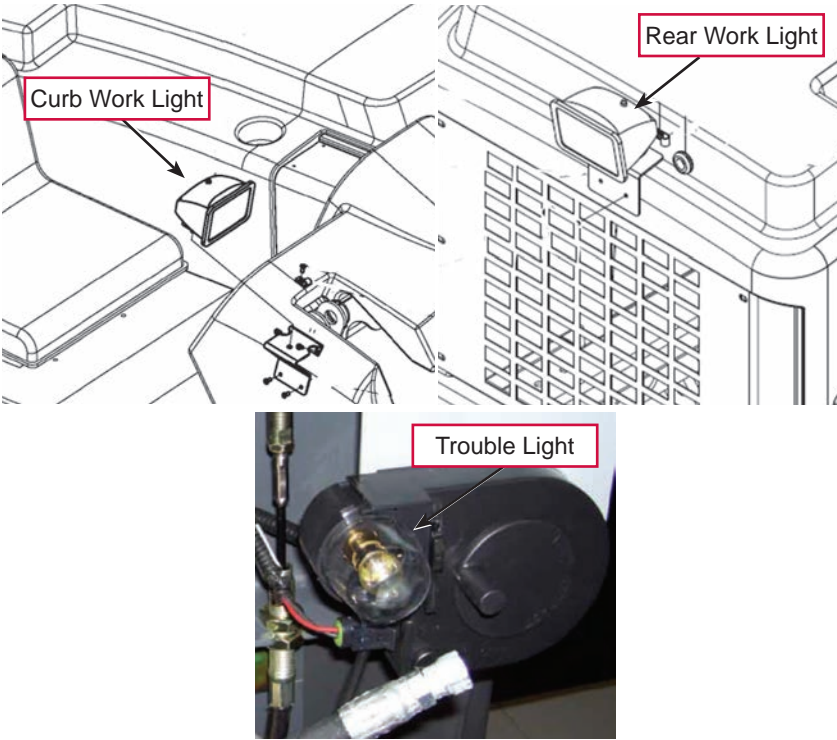
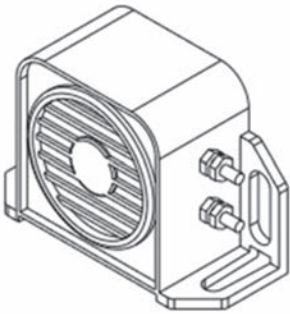
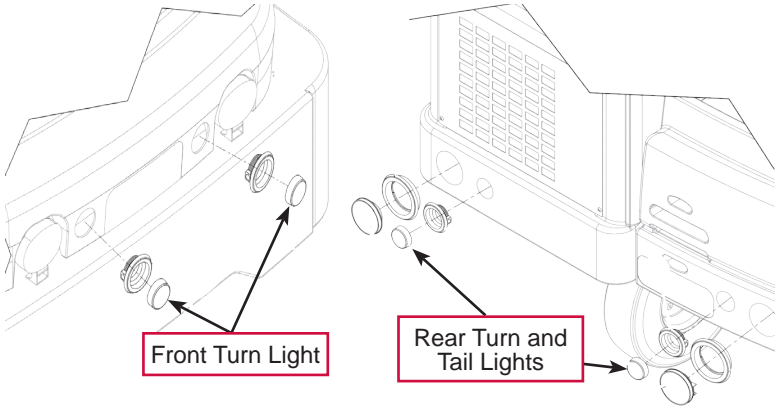
Description	Illustration
<p>Work Light Kit The Work Light Kit includes three lights: a Curb Work Light, a Rear Work Light, and a Trouble Light.</p>	 <p>The illustration for the Work Light Kit consists of three parts. On the left, a line drawing shows a 'Curb Work Light' mounted on a machine's side panel. On the right, another line drawing shows a 'Rear Work Light' mounted on the rear of the machine. Below these, a photograph shows a 'Trouble Light' which is a circular lamp with a clear lens and a black housing, mounted on a bracket.</p>
<p>Back Up Alarm Kit The Back-Up Alarm Kit includes the Back-Up Alarm, electrical connector and mounting hardware. The Back-Up Alarm connects to the existing machine wiring to sound a warning when the machine is moving in reverse.</p>	 <p>The illustration shows a rectangular, box-like 'Back-Up Alarm' with a circular speaker grille on the front and two electrical connectors on the side.</p>
<p>Brake/Signal Light Kit</p>	 <p>The illustration for the Brake/Signal Light Kit shows two line drawings. The left drawing shows a 'Front Turn Light' being installed into a machine's front light housing. The right drawing shows 'Rear Turn and Tail Lights' being installed into the rear light housing.</p>

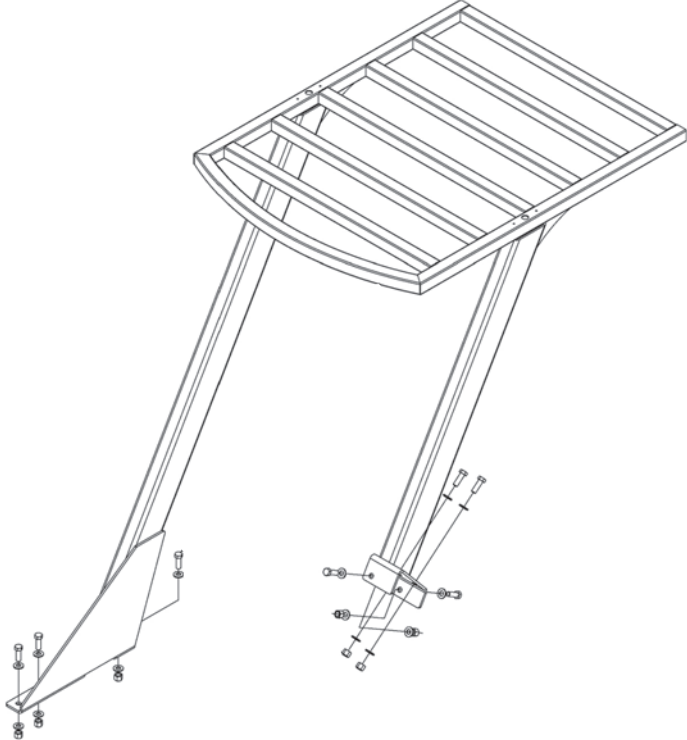
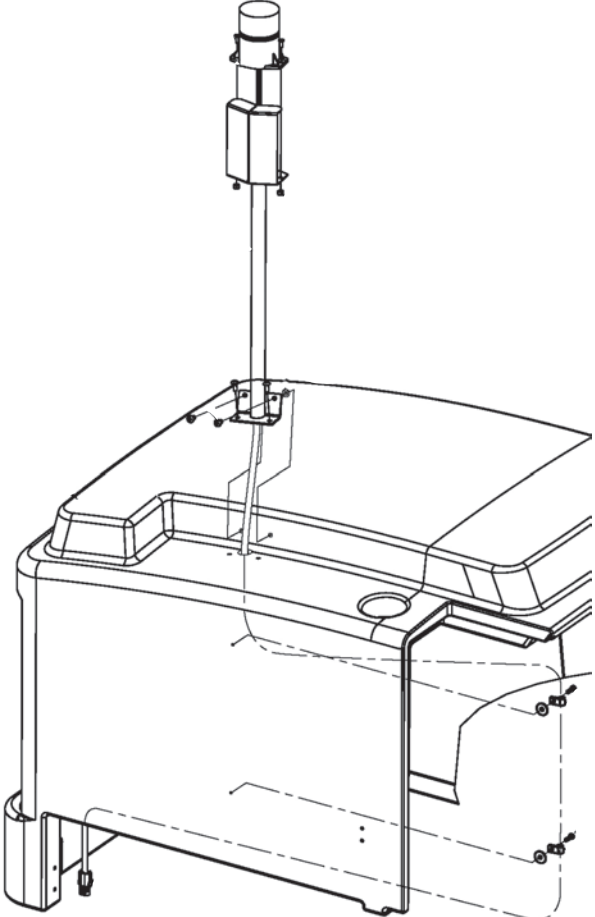
Description	Illustration
<p data-bbox="261 554 516 588">Overhead Guard Kit</p>	
<p data-bbox="233 1398 545 1461">Amber Strobe Kit, without Overhead Guard</p>	

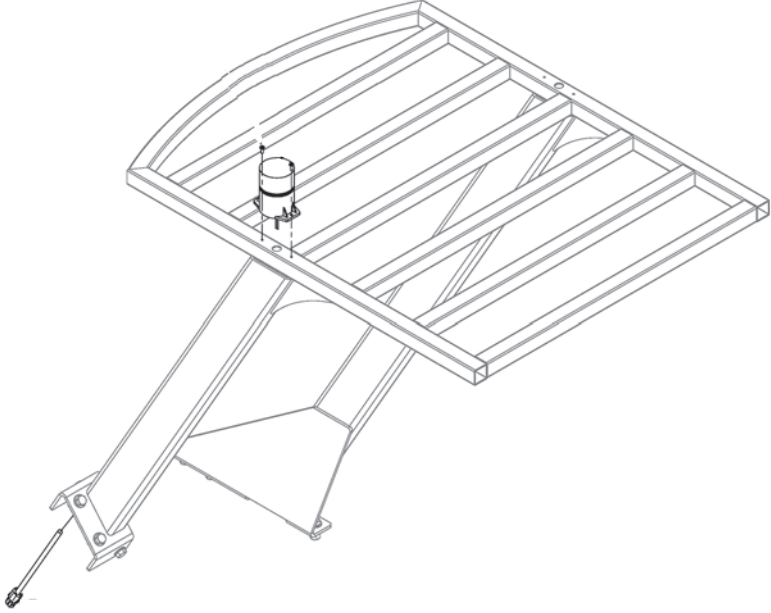
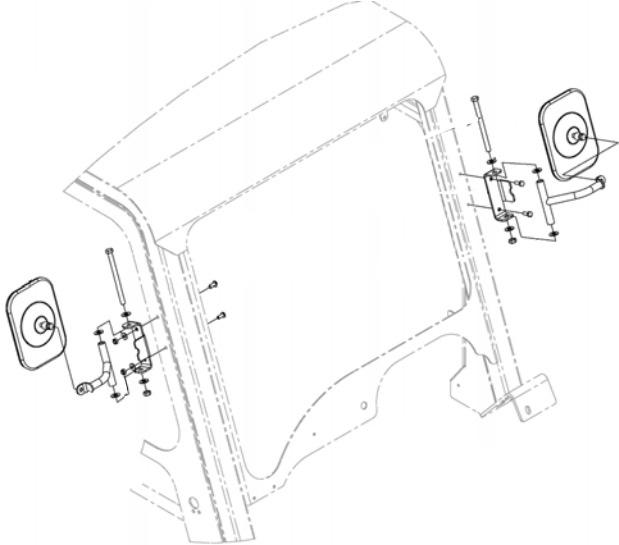
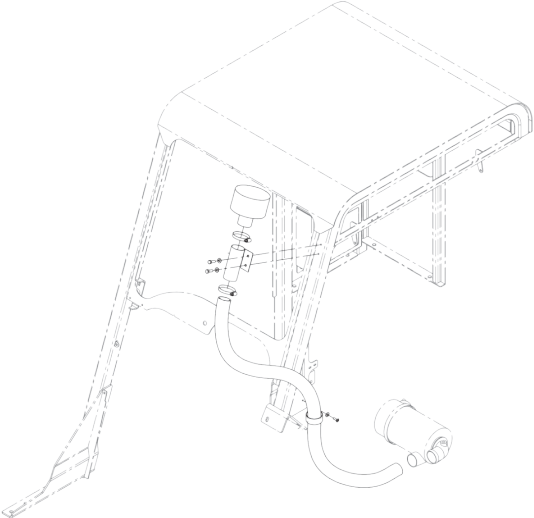
Description	Illustration
<p data-bbox="253 478 524 541">Amber Strobe Kit, with Overhead Guard</p>	 A technical line drawing of an amber strobe kit. It features a rectangular overhead guard with a curved front edge, supported by a sturdy metal frame. A central cylindrical strobe light is mounted on the top surface of the guard. The entire assembly is attached to a mounting bracket with a pin and nut at the bottom.
<p data-bbox="241 1100 535 1136">Cab Side Mirror Option</p>	 A technical line drawing showing the installation of a side mirror on a cab. The drawing depicts the side profile of the cab with a mirror mounted on a bracket. The mirror is shown in two positions: one looking forward and one looking backward, demonstrating its adjustability. The mounting hardware, including brackets and bolts, is clearly detailed.
<p data-bbox="155 1656 623 1692">Raised Air Intake Kit for use with Cab</p>	 A technical line drawing of a raised air intake kit. It shows a vertical metal frame that supports a rectangular air intake box. A flexible air hose is connected to the bottom of the box and leads to a cylindrical air filter. The kit is designed to be mounted to the side of a cab, as indicated by the mounting brackets and the overall structure.

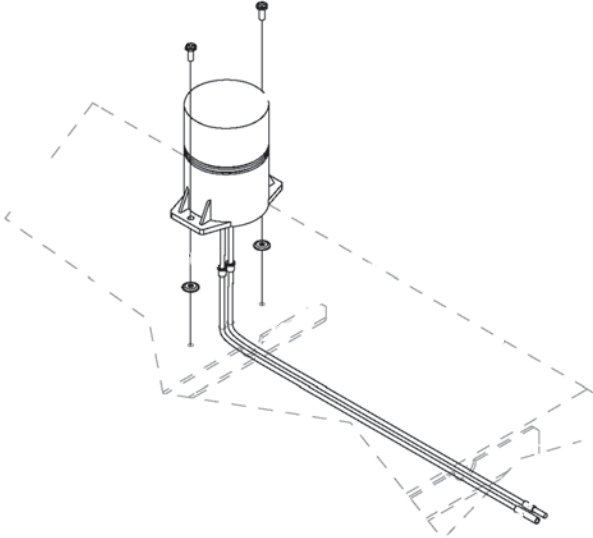
Description	Illustration
<p data-bbox="175 457 604 487">Amber Strobe Kit for use with Cab</p>	

SW8000 Deluxe Cab Options

The SW8000 Deluxe Cab is available with two levels of environmental control that provide additional comfort and convenience for the Operator, and add additional functionality to the machine.

- An optional cab heater is available which includes a pressurized cab with an external air filter.
- An optional heating and air conditioning system, along with pressurized cab is available that provides Operator comfort throughout a wide range of ambient temperatures.

Technical Specifications

Total Machine Height with Cab (Refer to Figure below.)		79.5 in (202 cm) without Amber Strobe Kit 84.5 in (215 cm) with Amber Strobe Kit installed
System Voltage		12 VDC
Heater Temperature Control		Electronic Water Valve w/Bypass
Blower Motors	Heating System	(1) Fasco OEM p/n 2807-510-154, Fasco p/n DC136, 1/8 HP, 4200 RPM, three-speed, 4.5 Amp
	A/C System	(2) SPAL type 008-A37/C-42D, 4.5 Amp
Refrigerant		R-134a, 1.3 lbs.
Condenser Fan Motor		SPAL, type VA13-AP9/C-35S, 6.9 Amp
Compressor		ICE TM-08-HD, 5 cu. in. (82.0 cc) per revolution, 700-6000 RPM
Compressor Motor		Sauer-Danfoss p/n 121.20.045.00, 1.02 cu. in. (16.7 cc) displacement
Heating System Capacity		20,000 BTUs/hr.
Air Conditioning System Capacity		13,000 BTUs/hr.

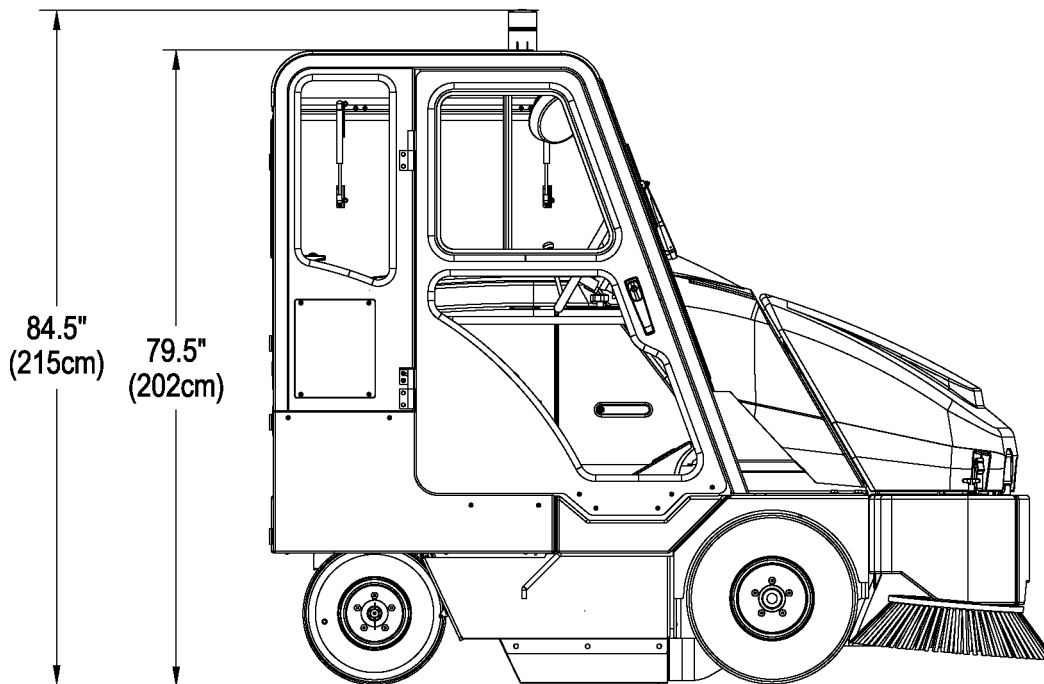

Figure 1. Cab Height

Cab Controls

(Refer to Figure 2)

1. Cooling Fan Switch
2. Dome Light
3. Heater A/C Fan Switch
4. Heater Temperature Control
5. A/C On/Off Switch
6. Windshield Wiper Switch

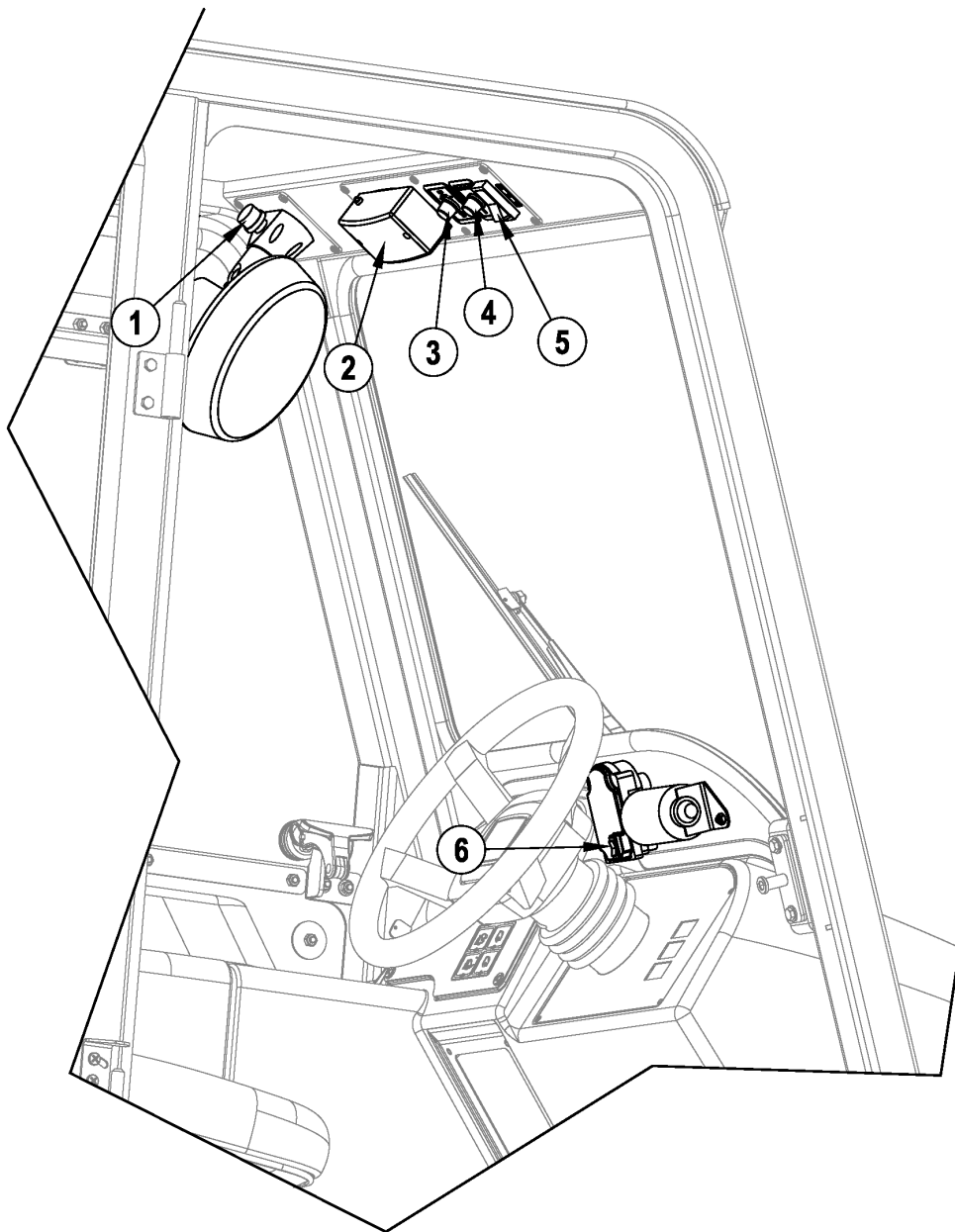

Figure 2. Cab Controls

Heating System Components

(Refer to Figure 3)

7. Blower Motor
8. Blower Assembly
9. Heater Core
10. Heater Air Box Assembly
11. Filter
12. Coolant Tube (From Engine Radiator)
13. Cab Filter Cover
14. Heater Hoses
15. Heater Control Assembly
16. HVAC Relay

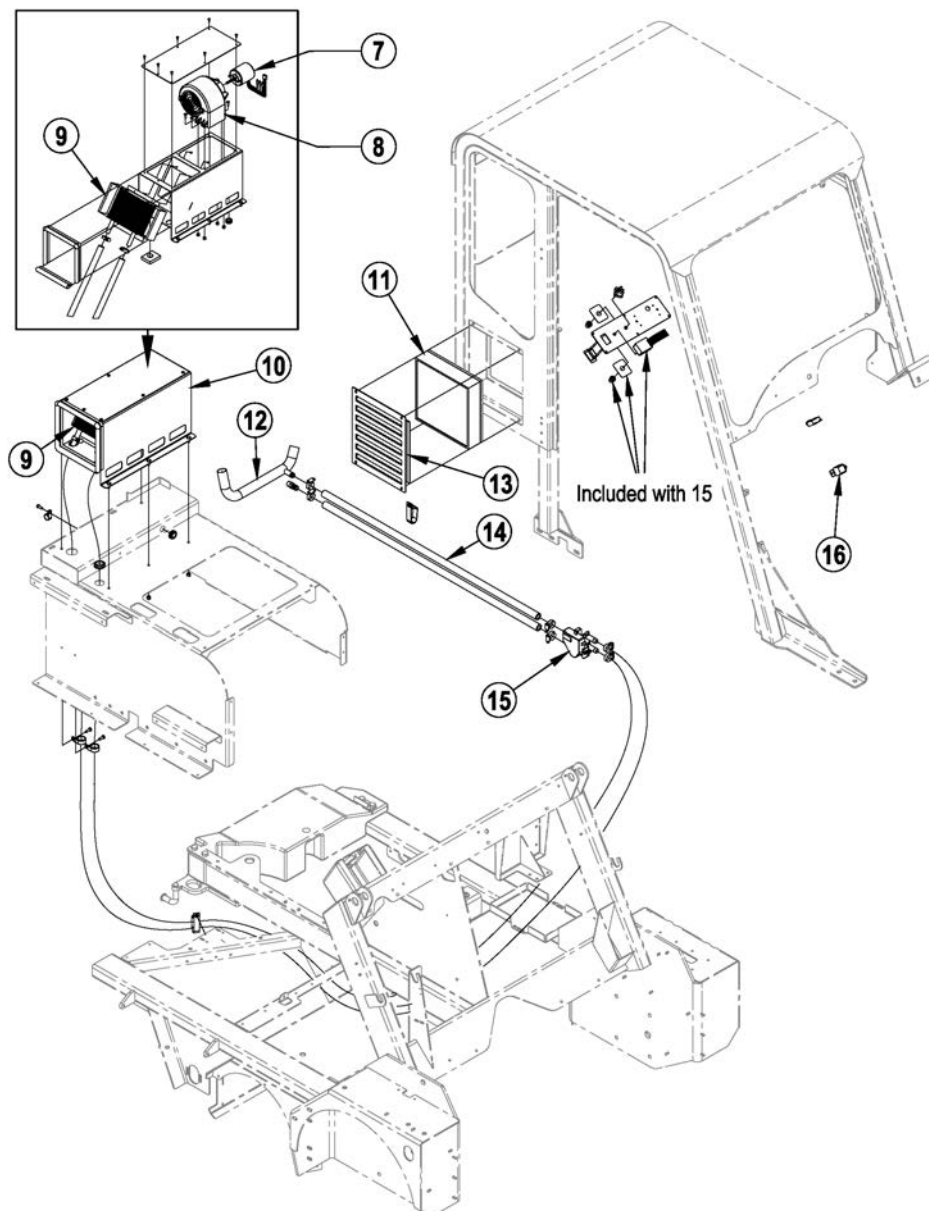

Figure 3. Heating System Components

Air Conditioning System Components

(Refer to Figure 4)

- | | |
|---|-------------------------------------|
| 17. Evaporator-Heater Unit | 18. A/C Condenser |
| 19. Binary Pressure Switch | 20. A/C Receiver/Dryer |
| 21. A/C Compressor | 22. Hydraulic Compressor Motor |
| 23. Air Filter | 24. Cab Filter Cover |
| 25. Coolant Tube (From Engine Radiator) | 26. Heater Hoses |
| 27. Heater Control Assembly | 28. Accessory (Gear) Hydraulic Pump |
| 29. Compressor Motor Hydraulic Valve | 30. Compressor Relay |
| 31. HVAC Relay | |

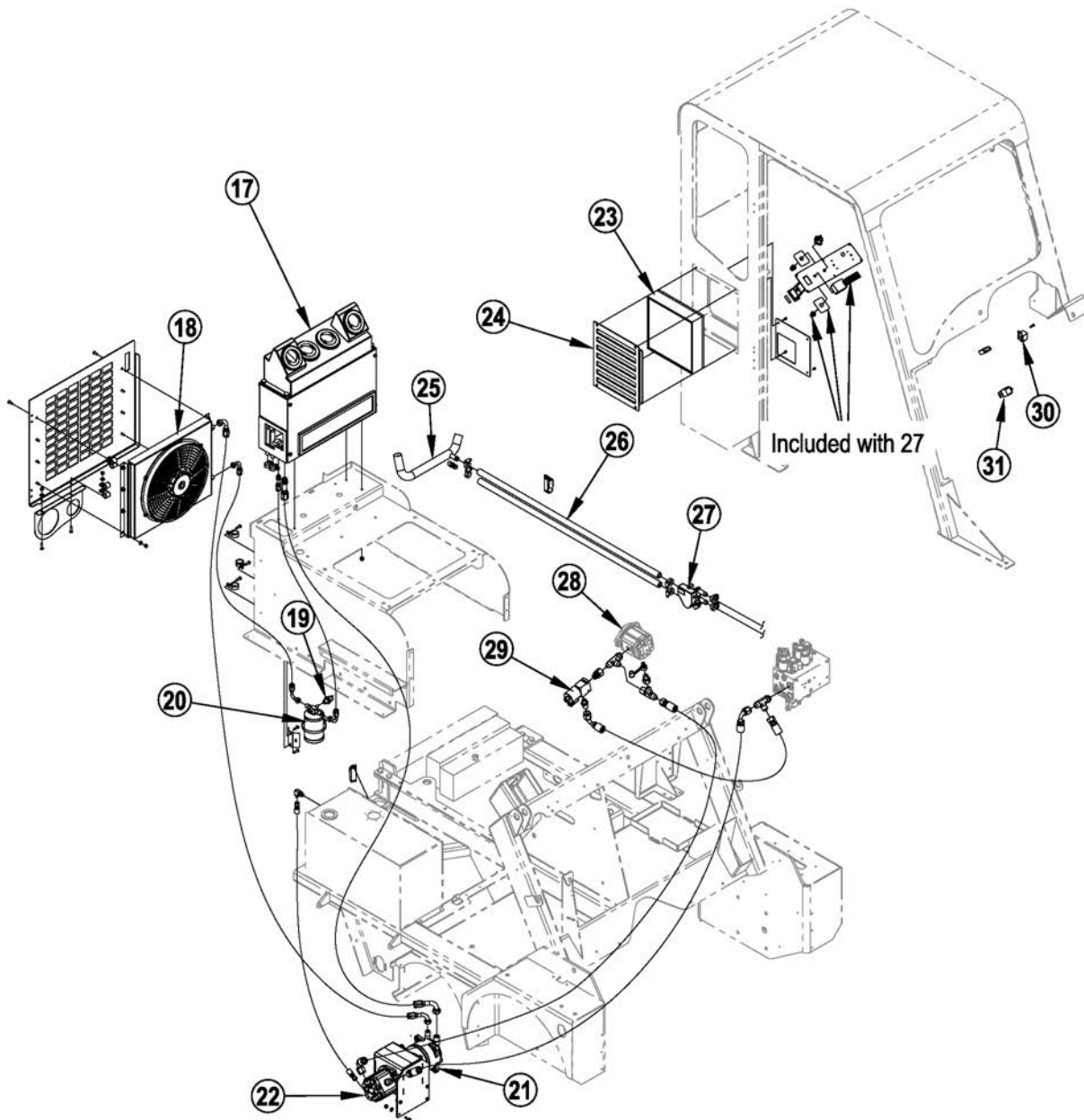

Figure 4. Air Conditioning System Components

Maintenance



Warning! Turn the key switch off and remove the key from the ignition switch before performing any machine maintenance.

Maintenance Schedule

Maintenance intervals given are for average operating conditions. Machines used in severe operational environments may require service more often.

Maintenance Item	Daily	Weekly	Monthly	Hours
Check for any coolant, hydraulic or refrigerant leaks. Note: Refrigerant leaks can appear as dirty, oily areas around A/C components and fittings.	X			8-12
Check the cab filter and clean or replace as necessary. Note: The cab filter may need to be cleaned or replaced more often if the machine is operated in dusty environments.		X		40
Clean the heater core fins and air box (heater only).			X	160
Clean the evaporator and heater core fins inside the evaporator-heater unit (A/C only).			X	160
Clean the condenser fins (A/C only).		X		40

To Clean and Replace the Cab Filter

(Refer to Figure 5)

- Remove the four screws holding the Cab Filter Cover, then remove the Cab Filter Cover and Filter from the machine.
- Clean the Filter using any of the following methods:
 - Tap the Filter gently on a flat surface (dirty side down).
 - Clean the Filter with compressed air (100 psi max.) blown from the inside (cab side) of the Filter.
 - Soak the Filter in warm water for 15 minutes, rinse with clean water (40 psi max. water pressure), then air-dry (don't use compressed air). Make sure the Filter is completely dry before reinstalling.
- Reinstall the Filter and Cab Filter Cover, then reinstall and tighten the four screws.

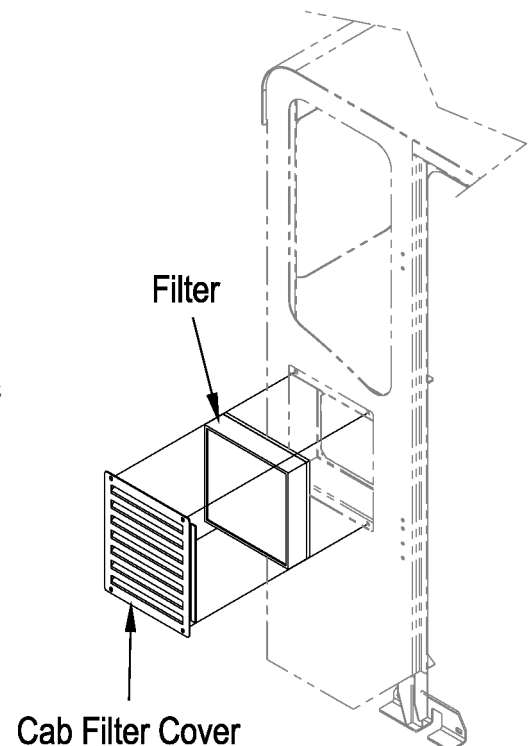

Figure 5. Cab Filter

Heating System

General System Overview

The SW8000 cab heating system uses an electronic Heater Control Assembly to direct the appropriate amount of engine coolant to the Heater Core in the Heater Air Box Assembly. The Blower Assembly in the Heater Air Box Assembly blows filtered air through the Heater Core to provide warm air to the cab.

A four-port bypass butterfly valve in the Heater Control Assembly, run by a small electric motor, controls the coolant flow to the Heater Core. The Heater Temperature Control in the cab controls the voltage to the valve motor, and uses a feedback potentiometer to sense the position of the butterfly valve.

Electrical Circuit Overview

Heater Blower Motor

The following conditions must be met for the blower motor to function:

Positive (+) Voltage

- The key switch (S1) must be in either the accessory or ignition position to provide +12 VDC (GRN/BLU wire) to the 20A circuit breaker CB4.
- Circuit breaker CB4 must be closed to provide +12 VDC (VIO wire) to the control side (coil) of the HVAC Relay K8.
- The 20A circuit breaker CB9 must be closed to provide voltage (RED/VIO wire) to the input load side of the HVAC Relay K8.
- HVAC Relay K8 must be closed to provide +12 VDC (VIO/GRAY wire) to the positive terminal on the Fan Switch S30.
- The Fan Switch S30 must be set to the Low (YEL wire), Medium (RED wire) or High (ORN wire) position to provide +12 VDC to the corresponding terminal on the Blower Motor M6.

Negative (-) Voltage

The Blower Motor M6 must be connected to battery negative (BLK wire).

The control side (coil) of the HVAC Relay K8 must be connected to battery negative (BLK wire).

Heater Temperature Control

The following conditions must be met for the heater temperature control to function:

Positive (+) Voltage

- The key switch must be in either the accessory or ignition position to provide +12 VDC (GRN/BLU wire) to the 20A circuit breaker CB4.
- Circuit breaker CB4 must be closed to provide +12 VDC (VIO wire) to the control side (coil) of the HVAC Relay K8.
- The 20A circuit breaker CB9 must be closed to provide voltage (RED/VIO wire) to the input load side of the HVAC Relay K8.
- HVAC Relay K8 must be closed to provide +12 VDC (VIO/GRAY to RED wire) to the Heater Temperature Control E1.

Negative (-) Voltage

The Heater Temperature Control E1 (BLK wire) must be connected to battery ground.

The control side (coil) of the HVAC Relay K8 must be connected to battery negative (BLK wire).

Electrical Troubleshooting

Note: Refer to the Electrical Wiring and Ladder Diagrams in the Appendix.

Symptom: The heater Blower Motor will not run.

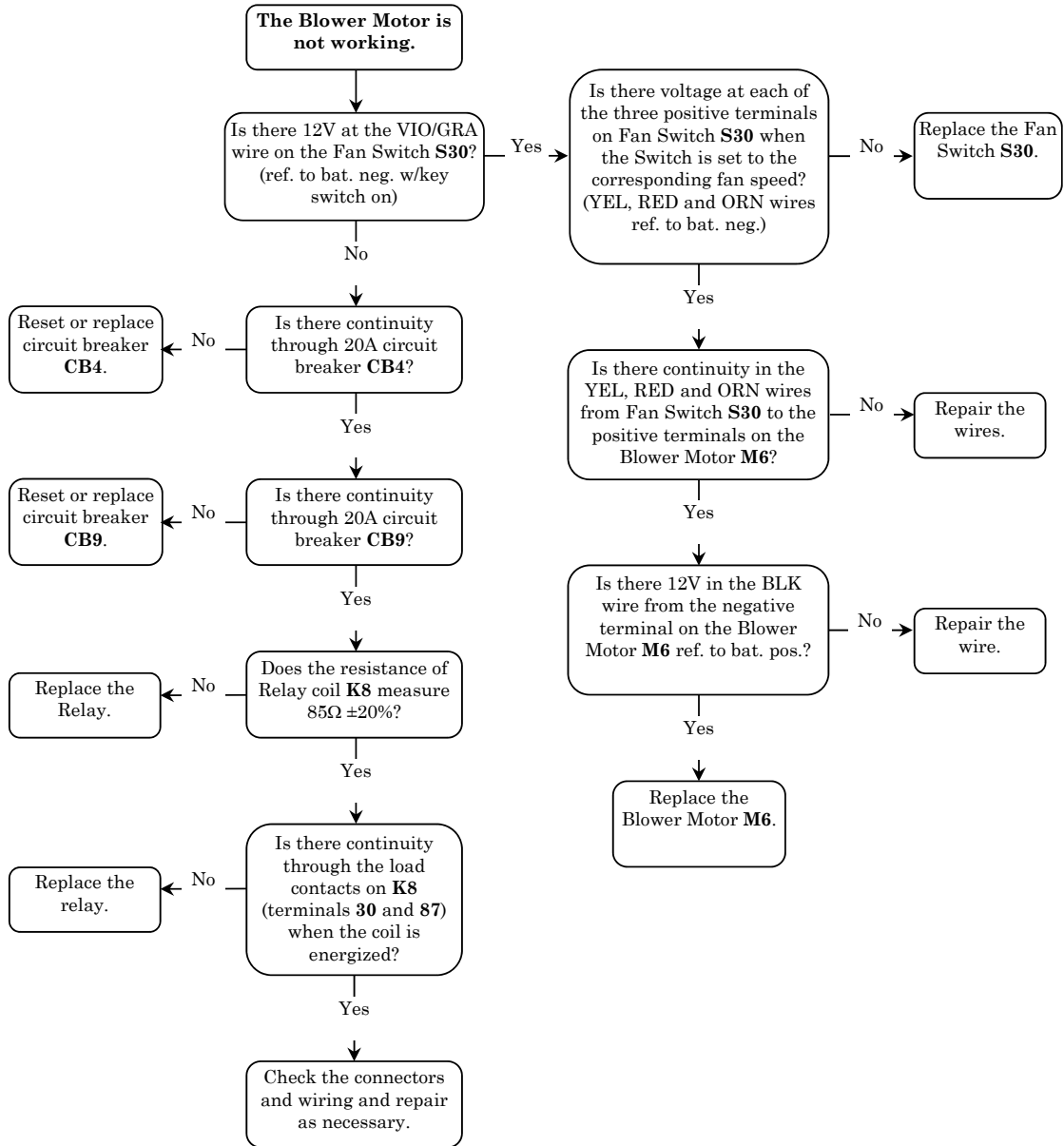

Symptom: There is no cab heat, or the cab heat cannot be controlled.

Note: Before troubleshooting the heating system, make sure the engine is up to normal operating temperature, the engine coolant is at the recommended level and there are no air locks in the cooling system. (Refer to the To Eliminate Air Locks from the Cooling System subsection.)

To Troubleshoot the Valve Assembly

1. Disconnect the electrical connector from the Valve Assembly.
2. Carefully connect a 12 VDC source to the Motor (-) and Motor (+) pins (directly or via the BLK/WHT and ORN wires in the connector) to run the butterfly valve motor independently without input from the heater temperature control.
3. Check for the heated coolant being switched on and off to the heater core. Note that it will take approximately 15-20 seconds for the valve motor to run between its full-off and full-on positions.
 - If the valve motor isn't running, replace the Valve Assembly.
 - If the valve motor appears to be running correctly, continue on to step 5 below.
4. Check the resistance through the Feedback Pins to determine if the feedback potentiometer in the Valve Assembly is working correctly. The resistance values should be close to those shown in the table below.

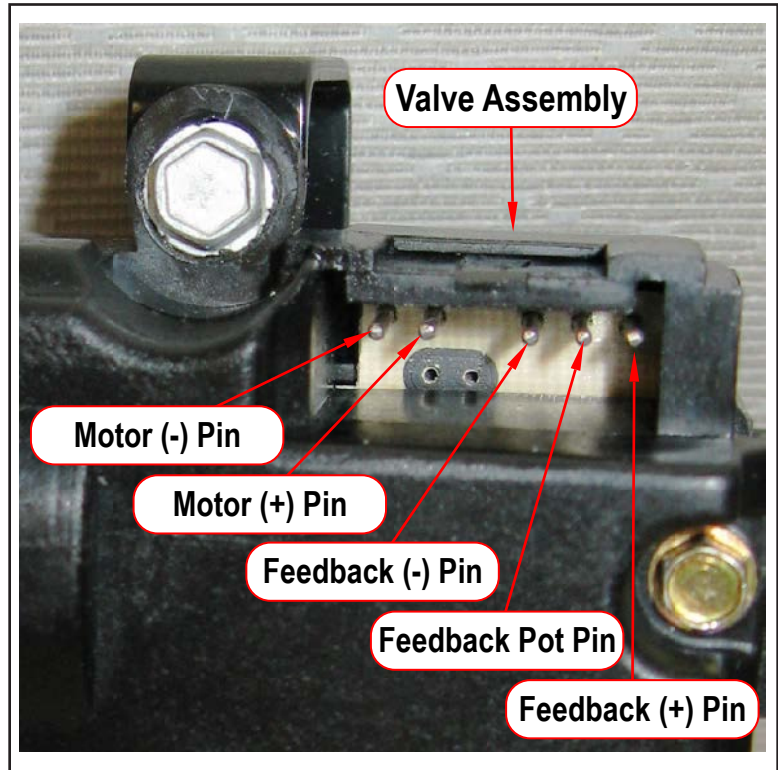
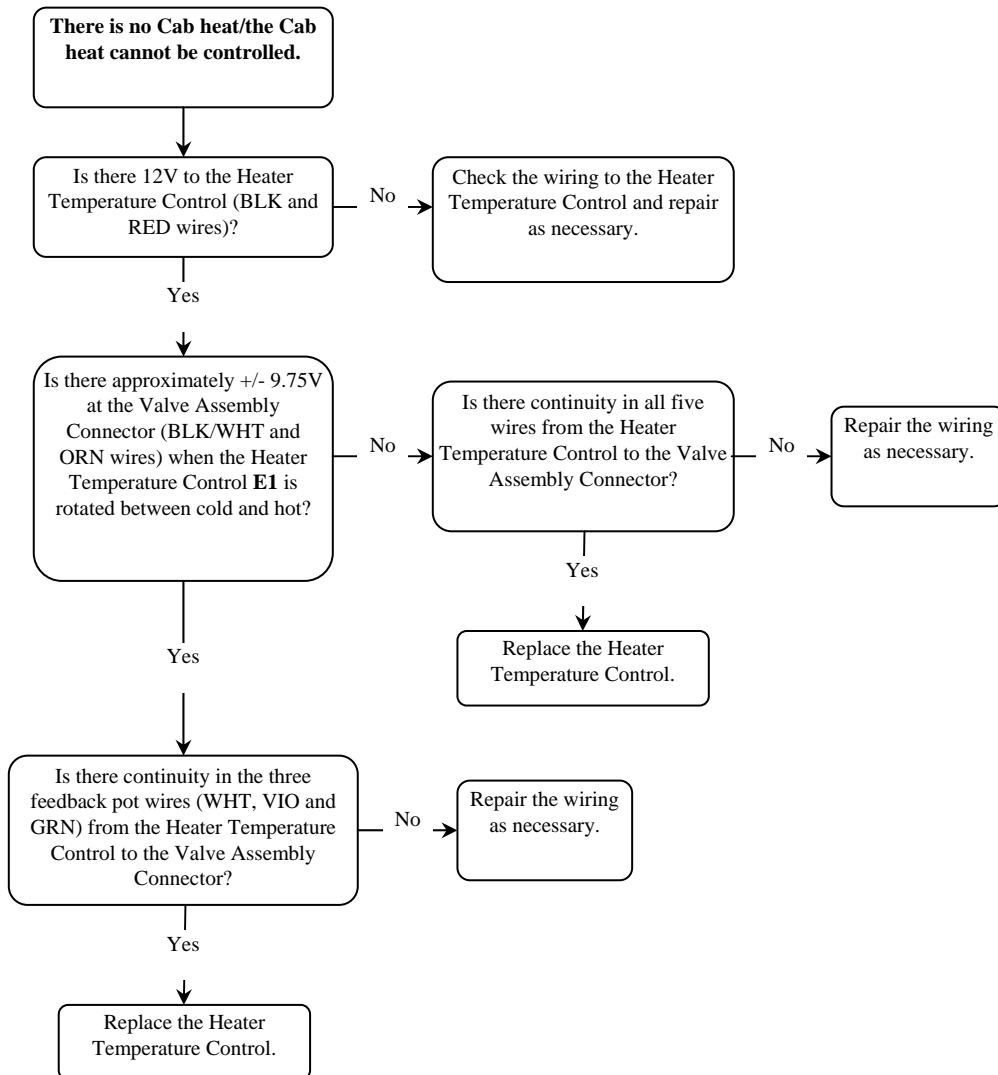

Figure 6. Valve Assembly Connector Pins

	Ohmmeter Connections	Resistance (Approximate)
Valve Open to Heater Core, Heater Temperature Control set to Hot (full clockwise)	Feedback (+) Pin and Feedback (-) Pin	5.71 kΩ
	Feedback (+) Pin and Feedback Pot Pin	5.55 kΩ
	Feedback Pot Pin and Feedback (-) Pin	0.88 kΩ
Valve Closed to Heater Core, Heater Temperature Control set to Cold (full counterclockwise)	Feedback (+) Pin and Feedback (-) Pin	5.71 kΩ
	Feedback (+) Pin and Feedback Pot Pin	0.48 kΩ
	Feedback Pot Pin and Feedback (-) Pin	5.63 kΩ
Valve Halfway Open, Heater Temperature Control set to approximate midpoint	Feedback (+) Pin and Feedback (-) Pin	5.71 kΩ
	Feedback (+) Pin and Feedback Pot Pin	3.14 kΩ
	Feedback Pot Pin and Feedback (-) Pin	3.25 kΩ

5. If the Feedback Pin resistance values are not close to those shown in the above table, it indicates that the feedback potentiometer in the Valve Assembly is not working correctly. Replace the Valve Assembly.

To Troubleshoot the Heater Temperature Control



Service Note: If you have to replace the Heater Temperature Control in the cab, we recommend that you do so as follows:

1. Remove the Overhead Control Plate from the cab.
2. Disassemble the Heater Temperature Control from the Overhead Control Plate.
3. Cut the seven wires going to the Heater Temperature Control at the point where they enter the sealed back of the module.
4. Check the continuity of the five wires going to the Valve Assembly (VIO, WHT, GRN, GRA/BLK WHT, and ORN).
 - If there is continuity in all five wires from the cab to the Valve Assembly, continue to step 5.
 - If there is no continuity in any of the five wires from the cab to the Valve Assembly, you will need to either repair the wires or run new wires to the Valve Assembly.
5. Install the replacement Heater Temperature Control on the Overhead Control Plate.
6. Splice the original wires from the Valve Assembly to the replacement Heater Temperature Control using butt connectors and heat-shrink insulation.
7. Reinstall the Overhead Control Plate in the cab.

To Eliminate Air Locks from the Cooling System

Air locks (air bubbles) in the cooling system can prevent normal coolant flow to the heater core. One factor that can contribute to the formation of air locks is the fact that the heater cores in the SW8000 cabs are the highest point in the machine's cooling system. This can make it difficult to purge the air from the system using traditional methods more common to the automotive industry.

Cooling System Vacuum Filler

One recommended method for removing air locks is to drain the cooling system completely, then refill the system using a cooling system vacuum filler tool. This type of tool uses a Venturi vacuum generator to remove the air from the radiator as it fills the radiator with coolant.

Purge the Heater Circuit

Another method is to remove the hoses that run from the Valve Assembly to the heater core, fill the hoses with coolant to remove as much air as possible from the heater circuit, reinstall the hoses, then run the machine with the heater on to purge any remaining air from the system. Figure 7 shows the heater hose functions for reference.



Warning! Before attempting to remove the heater hoses, make sure:

- The engine is switched off.
- The machine coolant has cooled to a low enough temperature so as not to cause burns or injury to persons contacting the hoses or coolant.
- The cooling system temperature and pressure have decreased enough to allow you to remove the radiator cap to relieve the system pressure before removing the hoses.

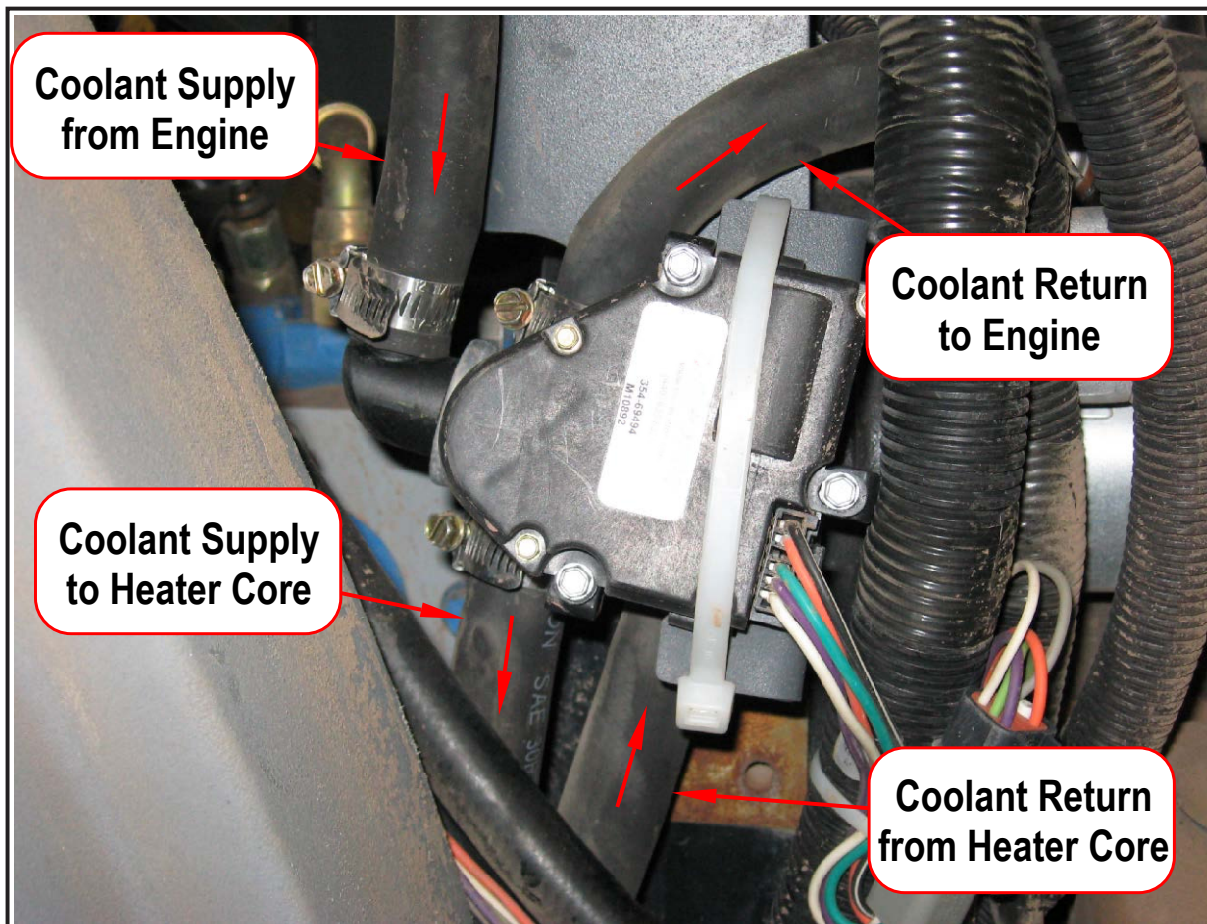

Figure 7. Valve Assembly Hose Functions

Air Conditioning System



Note: Refer to the schematics at the end of this chapter.

General System Overview

The SW8000 cab air conditioning system uses a Hydraulic Compressor Motor (22), powered by the Gear (Accessory) Hydraulic Pump (28), to run the A/C Compressor (21). The A/C Compressor compresses the refrigerant and transfers the hot, high-pressure refrigerant gas to the A/C Condenser (18) at the rear of the machine which condenses the refrigerant gas into a liquid. The condensed high-pressure liquid refrigerant travels from the A/C Condenser to the A/C Receiver/Dryer (20), then to the expansion valve and evaporator inside the Evaporator-Heater Unit (17) inside the cab. The cold, low-pressure refrigerant gas then returns to the A/C Compressor to complete the refrigeration cycle.

The Operator moderates the cab cooling by “mixing in” heated air from the heater core in the Evaporator-Heater Unit by adjusting the Heater Temperature Control (4).

The Thermostat (S33) (normally closed) has a temperature probe that is inserted into the evaporator coil in the Evaporator-Heater Unit. When the temperature of the evaporator coil reaches 39.5°F, the Thermostat closes to enable the A/C system. When the temperature of the evaporator coil drops to 31°F, the Thermostat opens to switch off the A/C system.

The Binary Pressure Switch (S34) (19) (normally closed), located on top of the A/C Receiver/Dryer, will interrupt the +12 VDC to the Compressor Motor Hydraulic Valve (L10) (29) to switch off the Hydraulic Compressor Motor and A/C Compressor under the following two conditions:

The refrigerant line pressure drops below 30 psig, indicating an insufficient amount of refrigerant in the system.

The refrigerant line pressure rises above 270 psig, indicating an overheated or unsafe condition.

The Compressor Relay (K10) (30) will interrupt the +12 VDC to the Compressor Motor Hydraulic Valve (L10) to switch off the Hydraulic Compressor Motor and A/C Compressor whenever the hopper is raised.

Electrical Circuit Overview

Blower Motors

The following conditions must be met for the blower motors to function:

Positive (+) Voltage

- The key switch must be in either the accessory or ignition position to provide +12 VDC (GRN/BLU wire) to the 20A circuit breaker CB4.
- Circuit breaker CB4 must be closed to provide +12 VDC (VIO wire) to the control side (coil) of the HVAC Relay K8.
- The 20A circuit breaker CB9 must be closed to provide voltage (RED/VIO wire) to the load side of the HVAC Relay K8.
- The HVAC Relay K8 must be closed to provide +12 VDC (VIO/GRAY wire) to the positive terminal on the Fan Switch S30.
- The Fan Switch S30 must be set to the Low (YEL wire), Medium (RED wire) or High (ORN wire) position to provide +12 VDC to the corresponding terminals on the Blower Motors M9 and M10.

Negative (-) Voltage

The Blower Motors M9 and M10 must be connected to battery negative (BLK wires).

The control side (coil) of the HVAC Relay K8 must be connected to battery negative (BLK wire).

Condenser Fan, Thermostat, Pressure Switch and Compressor Motor

The following conditions must be met for the air conditioning system to function:

Positive (+) Voltage

- The key switch must be in either the accessory or ignition position to provide +12 VDC (GRN/BLU wire) to the 20A circuit breaker CB4.
- Circuit breaker CB4 must be closed to provide +12 VDC (VIO wire) to the control side (coil) of the HVAC Relay K8.
- The 20A circuit breaker CB9 must be closed to provide voltage (RED/VIO wire) to the load side of the HVAC Relay K8.
- HVAC Relay K8 must be closed to provide +12 VDC (VIO/GRA wire) to the positive terminal on the Fan Switch S30.
- The Fan Switch S30 must be set to the Low, Medium or High position to provide +12 VDC (RED/WHT wire) to the AC Switch S35.
- The AC Switch S35 must be closed to provide +12 VDC to:
 - The control side (coil) of the Condenser Fan Relay K9 (WHT wire).
 - The input terminal on the Thermostat S33 (BLK/WHT wire).
- The Thermostat S33 (normally closed) must be closed to provide +12 VDC (GRN wire) to the input terminal on the Pressure Switch S34.
- The Binary Pressure Switch S34 (normally closed) must be closed to provide +12 VDC (GRN/WHT wire) to the load side of the Compressor Relay K10 (terminal 30).
- The load side of the Compressor Relay K10 (normally closed) must be closed to provide +12 VDC (BLU/BRN wire from terminal 87a) to the Compressor Hydraulic Valve L10.



Note: *The Compressor Relay K10 coil (control side) is wired in parallel with the Hopper Up/Down Hydraulic Valve L5. When the Raise Hopper switch is pressed, it actuates the Hopper Up/Down Hydraulic Valve L5 to raise the hopper, and actuates the Compressor Relay K10 coil to open the circuit to the Compressor Hydraulic Valve L10 and switch off the A/C compressor motor. This feature allows the machine to use the maximum available hydraulic force to raise the hopper.*

Negative (-) Voltage

- The control side (coil) of the Condenser Fan Relay K9 must be connected to battery negative (BLK wire).
- The control side (coil) of the Compressor Hydraulic Valve L10 must be connected to battery negative (BLK wire).
- The control side (coil) of the HVAC Relay K8 must be connected to battery negative (BLK wire).

Electrical Troubleshooting



Note: Refer to the Cab Electrical Wiring and Ladder Diagrams at the end of this chapter.

Symptom: One or both of the Blower Motors will not run.

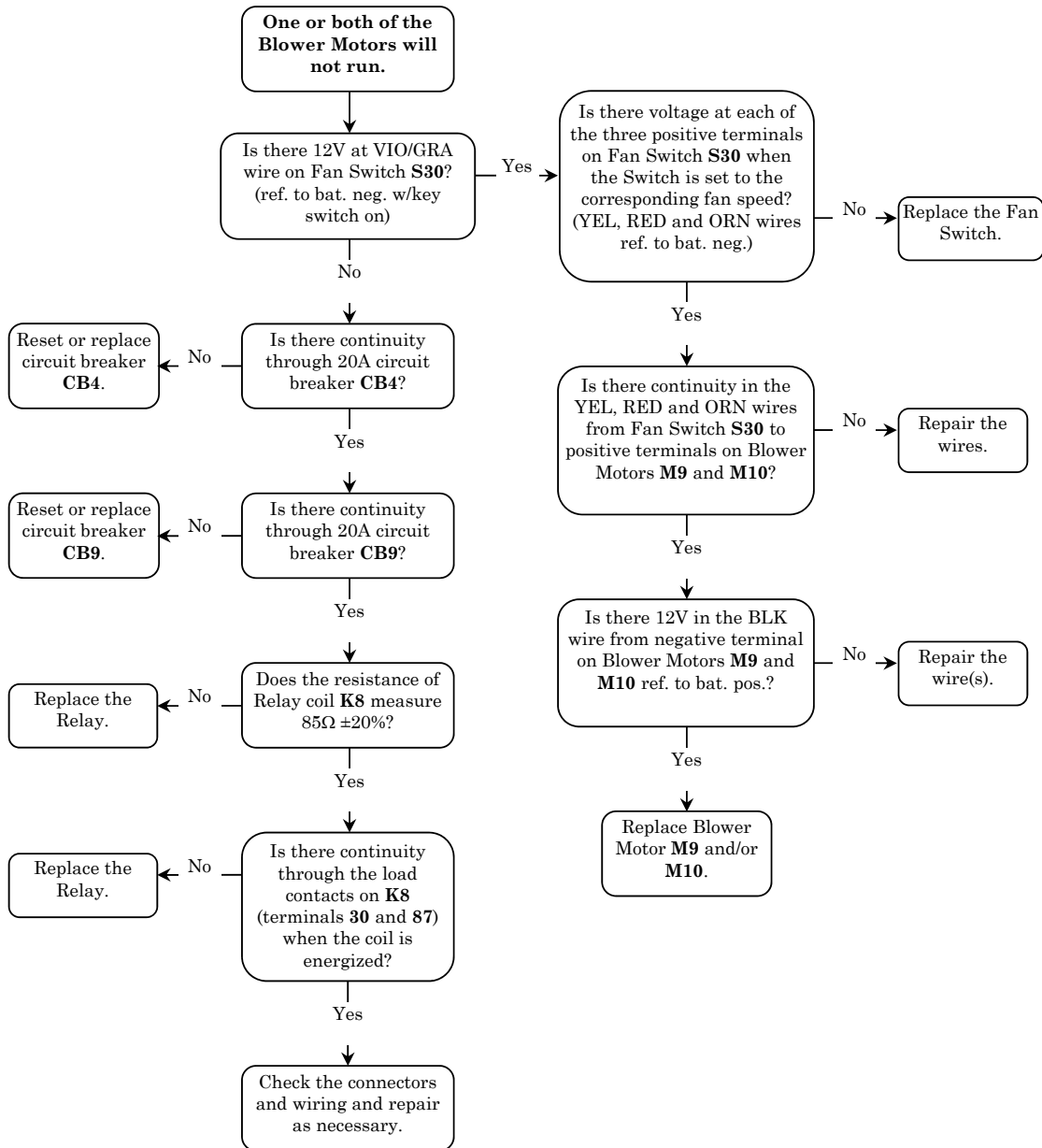

Symptom: The Blower Motors run but there is no cold air coming out of the Evaporator-Heater Unit.



Note: Before troubleshooting the air conditioning system, make sure the system is filled with the recommended amount of refrigerant. We recommend that you have this checked by a qualified technician or an EPA-certified air conditioning repair shop.



Note: Refer to the Cab Electrical Wiring and Ladder Diagrams in Appendix, and the Component Troubleshooting subsections on the following pages.

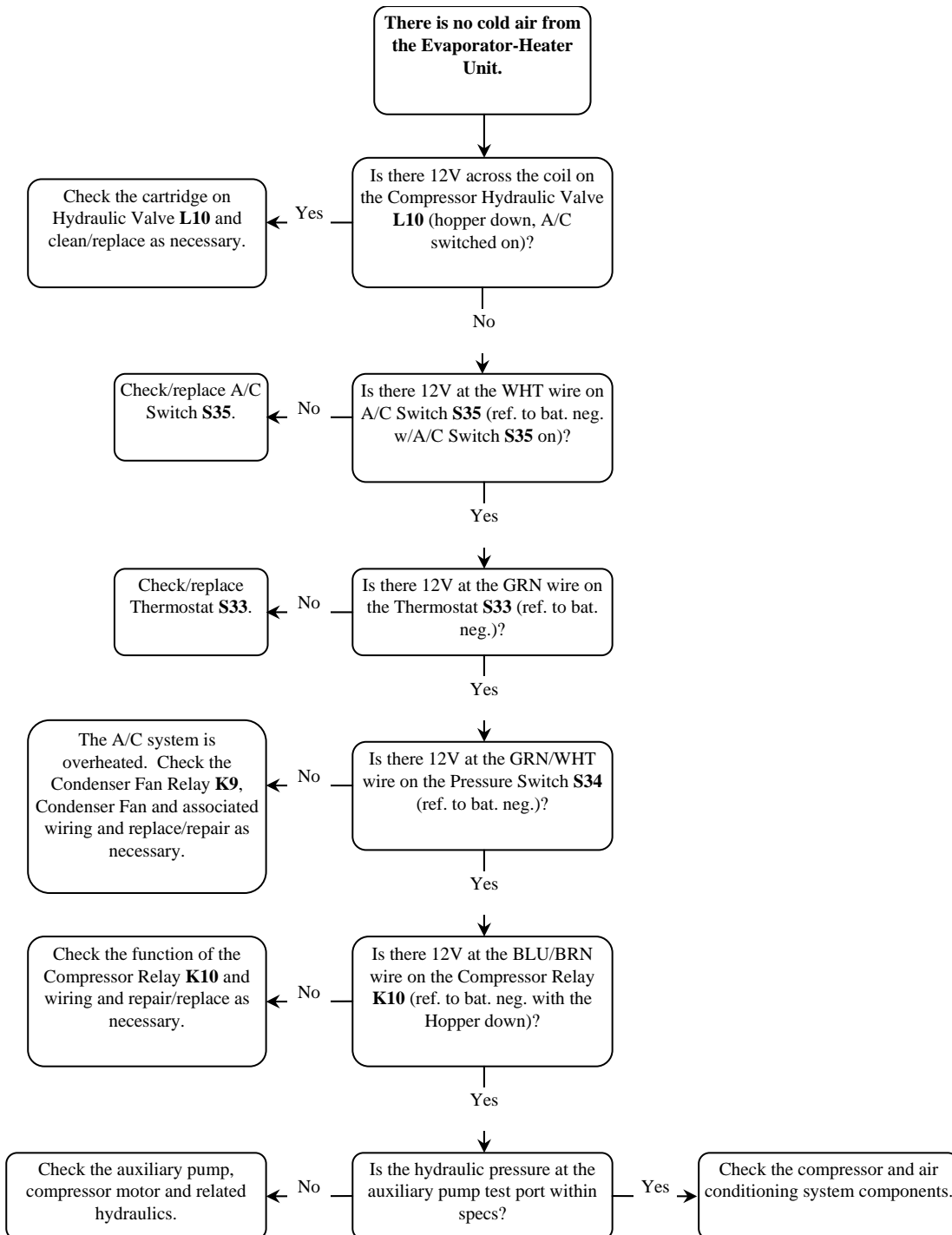

Component Troubleshooting

Compressor Motor Hydraulic Valve (L10)

(Refer to Figure 8)



Note: The Compressor Motor Hydraulic Valve and Hydraulic Pressure Test Port are attached to the tee-fitting off of the Accessory Hydraulic Pump.

1. Disconnect the Electrical Connector from the Hydraulic Valve.
2. Switch on the A/C and check for 12 VDC at the Electrical Connector.
3. Check the coil resistance of the Hydraulic Valve. It should be approximately 7 ohms \pm 20%.
4. If there is 12 VDC at the Electrical Connector and the coil resistance is within spec, disassemble the Hydraulic Valve and clean or replace the cartridge as necessary.

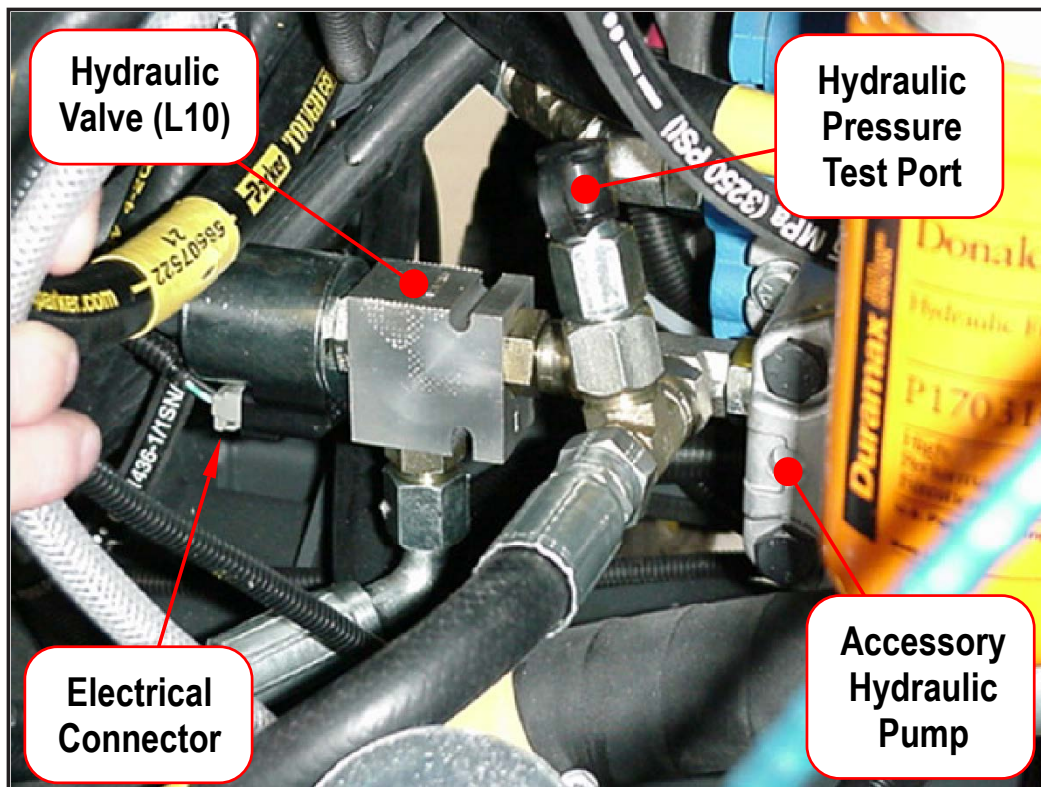

Figure 8. Compressor Motor Hydraulic Valve

Accessory (Gear) Hydraulic Pump

(Refer to Figure 8)

1. Connect a hydraulic pressure gauge to the Hydraulic Pressure Test Port off of the Accessory Hydraulic Pump.
2. Start the engine, then switch the A/C on and off at the two engine speeds and note the hydraulic pressures at the Hydraulic Pressure Test Port. The following chart shows pressure values that are representative of what you should be reading at normal operating temperature if the Accessory Hydraulic Pump, Hydraulic Valve and compressor motor are working correctly. Note that pressures tend to be higher if the hydraulic system is below normal operating temperature.

	Hydraulic Pressure at Test Port (typical)	Difference in Hydraulic Pressure between A/C off and A/C on
Engine at idle, A/C off	500 psi	380 psi
Engine at idle, A/C on	880 psi	
Engine at high speed, A/C off	675 psi	425 psi
Engine at high speed, A/C on	1100 psi	

If you don't observe differences in the hydraulic pressures similar to those in the above chart when switching the A/C on and off, it could indicate a problem with the Hydraulic Valve (L10), the Accessory Hydraulic Pump or the A/C compressor motor.

Compressor Relay (K10)

(Refer to Figure 9)



Note: The Compressor Relay is located in the engine compartment below the main broom lever.

1. Make sure the hopper is down, then switch on the A/C.
2. Back-probe the BLU/BRN wire connected to the Compressor Relay.
 - If you see 12 VDC at the BLU/BRN wire referenced to battery negative, the Compressor Relay is working correctly.
 - If you don't see 12 VDC at the BLU/BRN wire, proceed to step 3 below.
3. Remove the electrical connector from the Compressor Relay and check for continuity across the load terminals (30 and 87a).



Note: The Compressor Relay is a normally-closed relay and should have continuity across the load terminals with the electrical connector removed.

- If there is continuity across load terminals 30 and 87a, the Compressor Relay is working correctly. Check the connections and wiring upstream of the Compressor Relay and repair/replace as necessary.
- If there is very high resistance or no continuity across terminals 30 and 87a, replace the Compressor Relay.

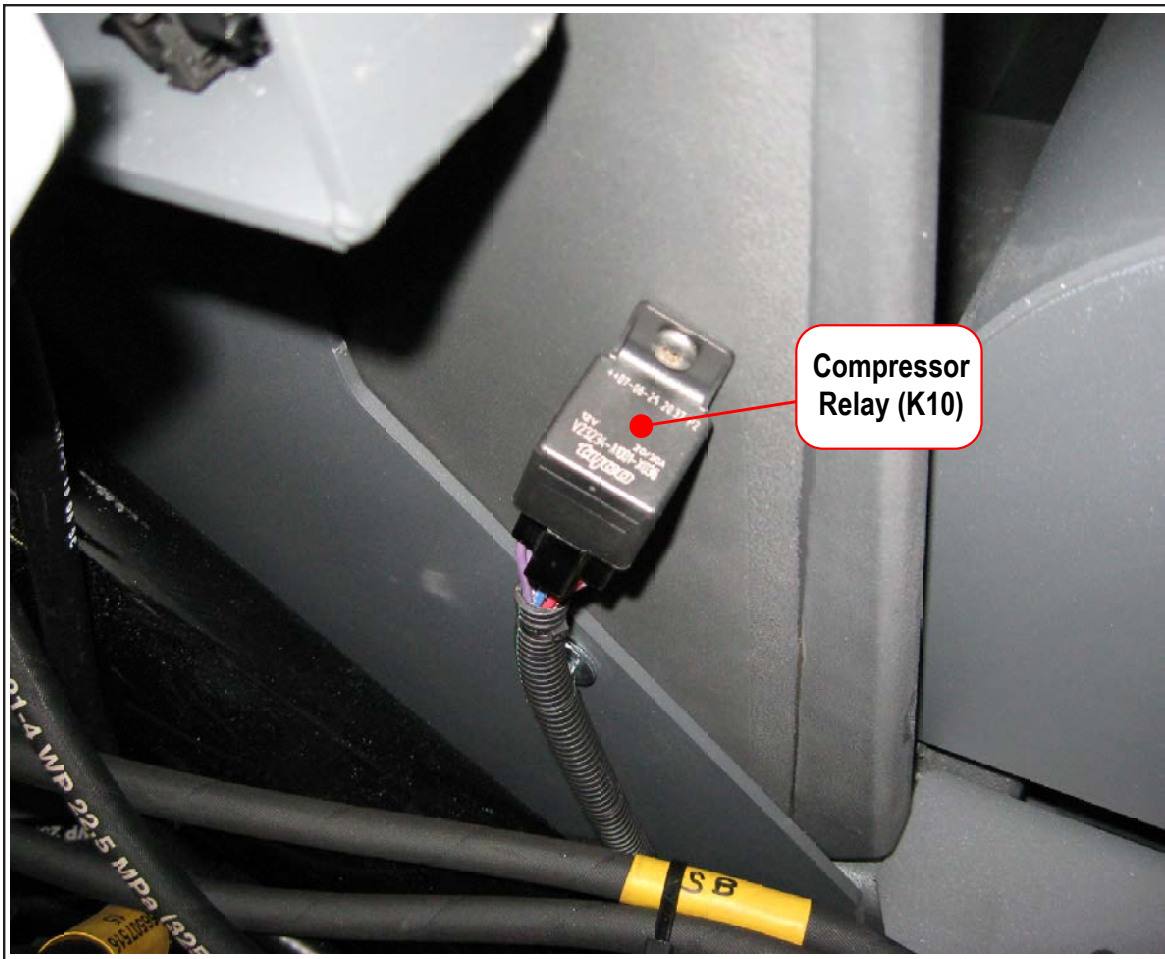

Figure 9. Compressor Relay



Warning! High-pressure side air conditioning components, fittings, lines and hoses can be extremely hot after operation and can cause severe burns. Always use the appropriate precautions when working around the Binary Pressure Switch, Receiver/Dryer or other A/C components.

Binary Pressure Switch (S34)

(Refer to Figure 10)



Note: The Binary Pressure Switch is mounted to the top of the A/C Receiver/Dryer at the rear of the machine, behind the hydraulic oil tank.

1. Open the rear Cover Assembly at the back of the cab.
2. Remove the electrical connector from the Binary Pressure Switch and check for continuity across the two terminals.



Note: The Binary Pressure Switch is normally closed and should have continuity across the terminals if the A/C system is charged adequately and is at normal ambient temperature.

- If there is continuity across the terminals, the Binary Pressure Switch is working correctly.
- If there is very high resistance or no continuity across the terminals, replace the Binary Pressure Switch.

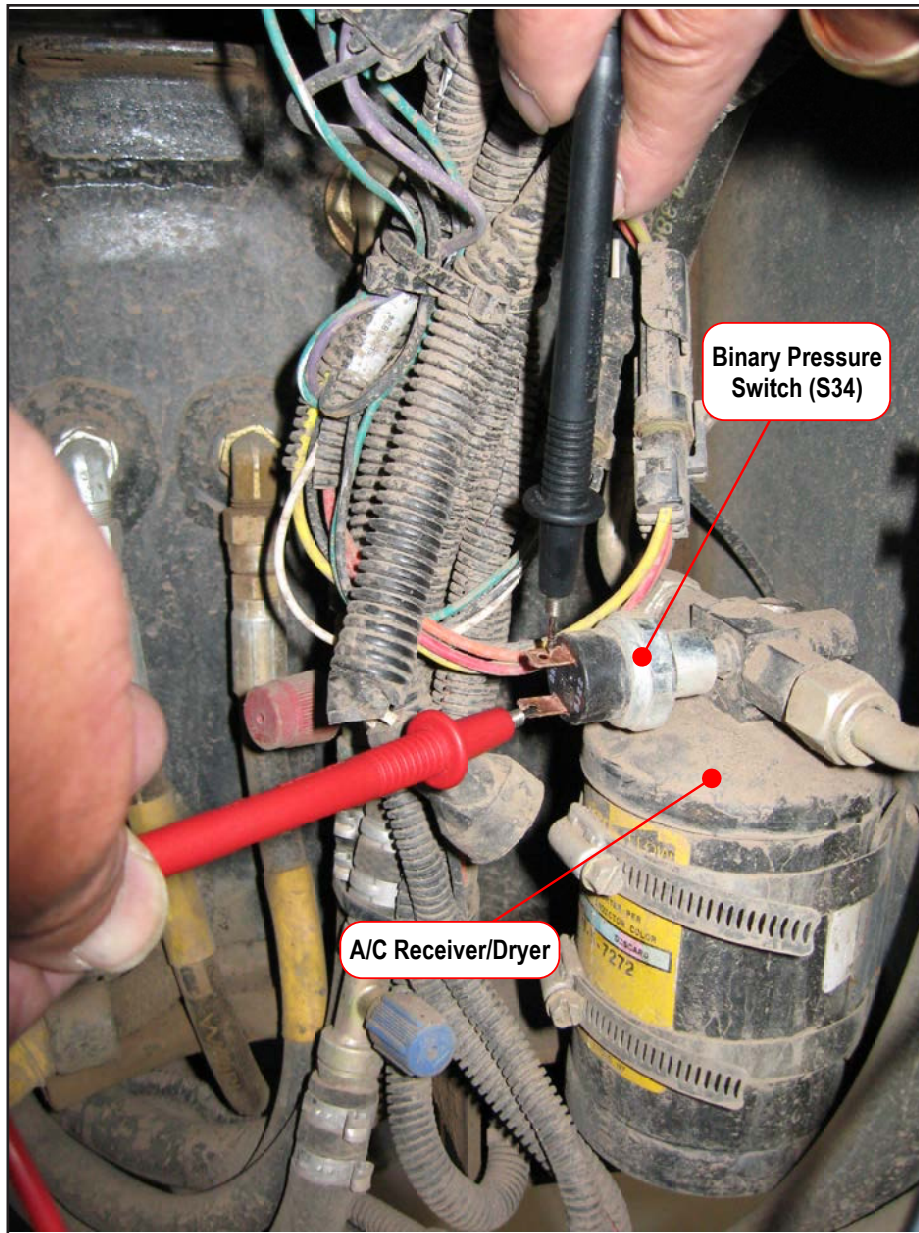

Figure 10. Checking Continuity through the Binary Pressure Switch

Thermostat (S33)

(Refer to Figure 11)



Note: The Thermostat is located inside the Evaporator-Heater Unit in the cab.

1. Remove the top cover/nozzle assembly from the Evaporator-Heater Unit.
2. Remove the front panel from the Evaporator-Heater Unit.
3. Remove the two electrical connectors (BLK/WHT and GRN wires) from the Thermostat and check the continuity across the two terminals.



Note: The Thermostat is normally closed and should have continuity across the terminals at ambient temperatures above 31° F.

- If there is continuity across the terminals, the Thermostat is working correctly.
- If there is very high resistance or no continuity across the terminals, replace the Thermostat.



Service Note: To verify that the thermostat is operating correctly, spray electronic component cooler or canned air dusting spray onto the probe embedded in the evaporator coils to cool the probe to below 31° F.

- The Thermostat should open and you should read an open circuit through the terminals with the probe below 31° F.
- Once the probe warms up to 39.5° F, there should again be continuity through the Thermostat terminals.



Figure 11. Checking Continuity through the Thermostat

Heating and A/C System Plumbing and Hydraulic Flow Schematic

1. Heater Core
2. AC Evaporator
3. Radiator Coolant Tube
4. Feed Hot Water
5. Return Flow
6. Heater Control Valve
7. Hydraulic Test Port
8. Low Pressure Refrigerant (Gas)
9. High Pressure Gas
10. High Pressure Liquid

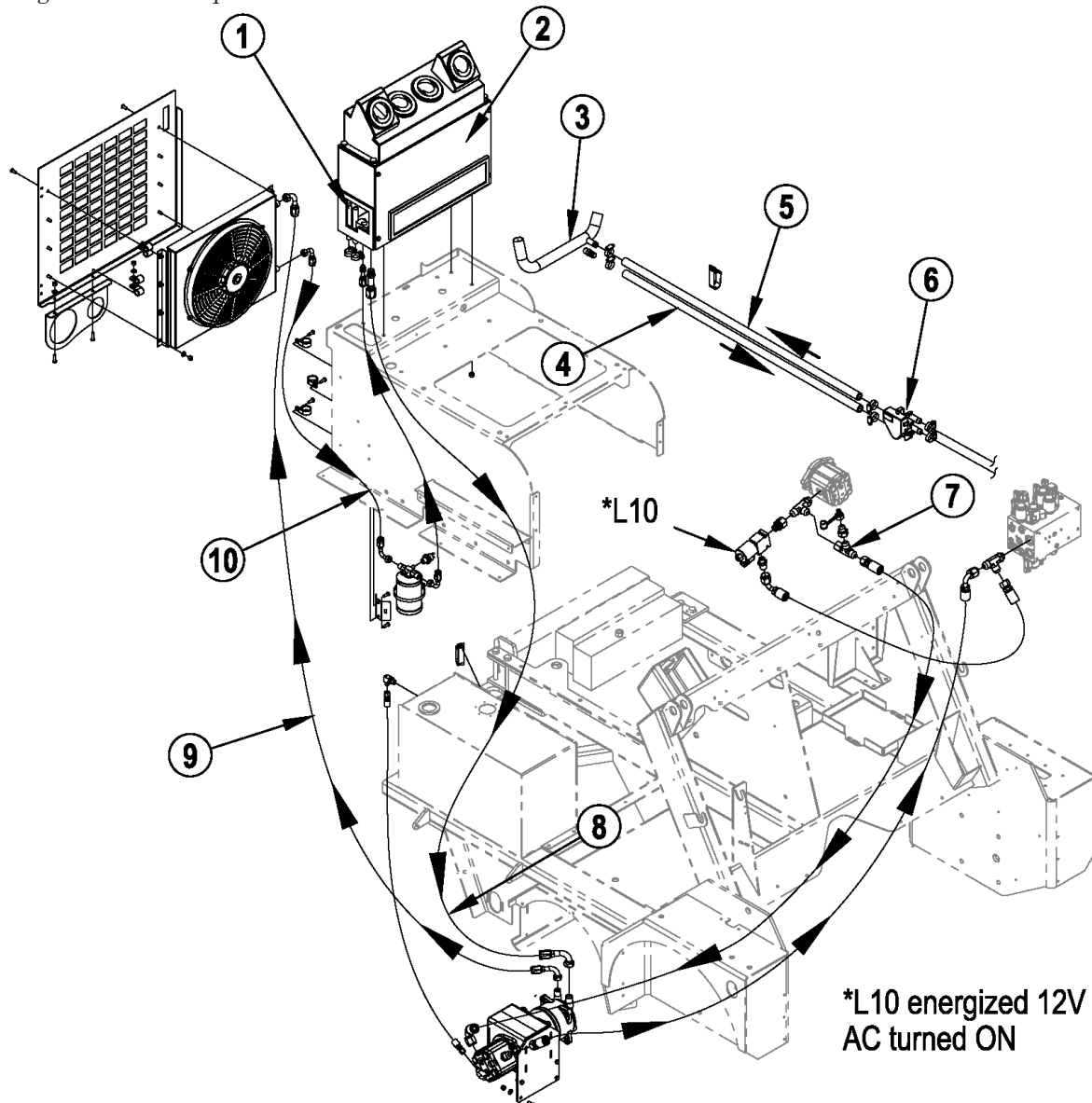

Steering System

Functional Description

Overview

The steering system includes the **Steering Wheel**, **Steering Control Unit**, **Steering Cylinder** and **Drive Yoke Weldment**.

The **Steering Wheel** rotates the shaft on the **Steering Control Unit** which controls the oil flow to the **Steering Cylinder**. The **Steering Cylinder** extends and retracts to rotate **Drive Yoke Weldment** to steer the **Rear Wheel Assembly**.

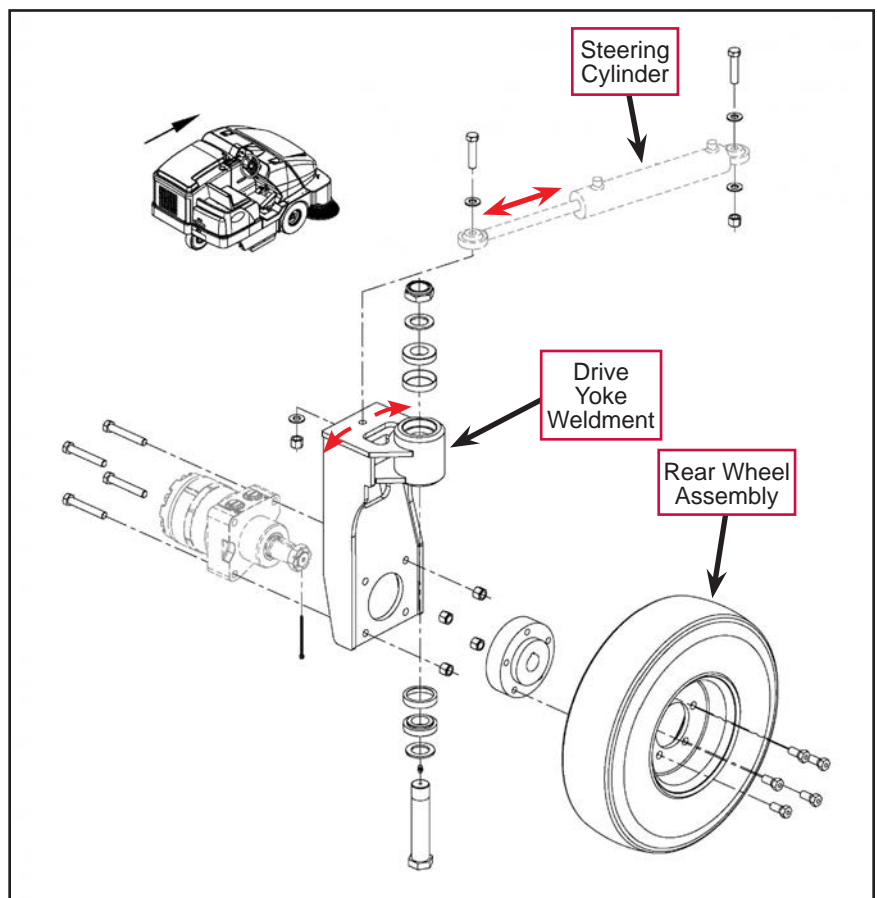
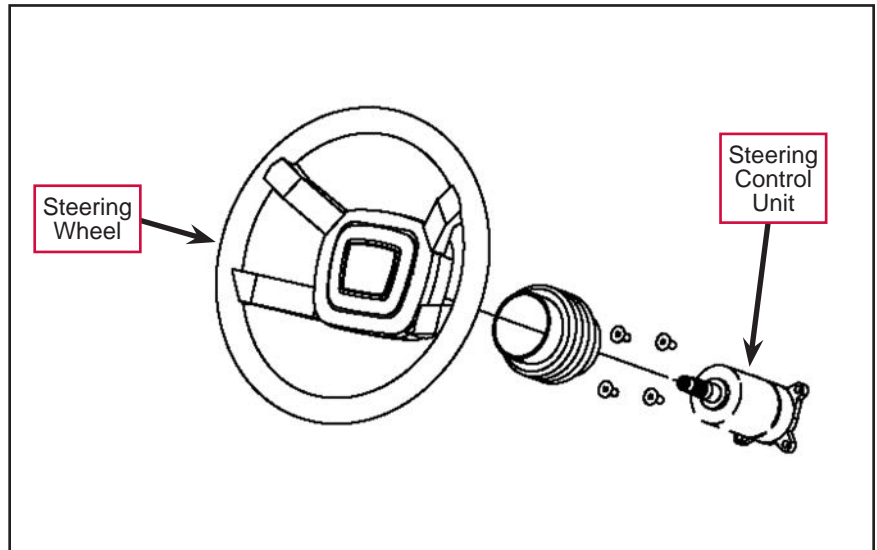

The “A” port on the **Hydraulic Manifold Assembly** supplies hydraulic oil to the “P” (pressure) port on the **Steering Control Unit**. The oil from the “T” (tank) port on the **Steering Control Unit** goes to the “T1” port on the **Hydraulic Manifold Assembly**, then to the oil cooler, filter and reservoir.

The **Steering Cylinder** is connected to the “R” and “L” ports on the **Steering Control Unit**. When the Operator turns the steering wheel, the **Steering Control Unit** directs the oil to the “R” or “L” port on the **Steering Cylinder** to steer the machine right or left.

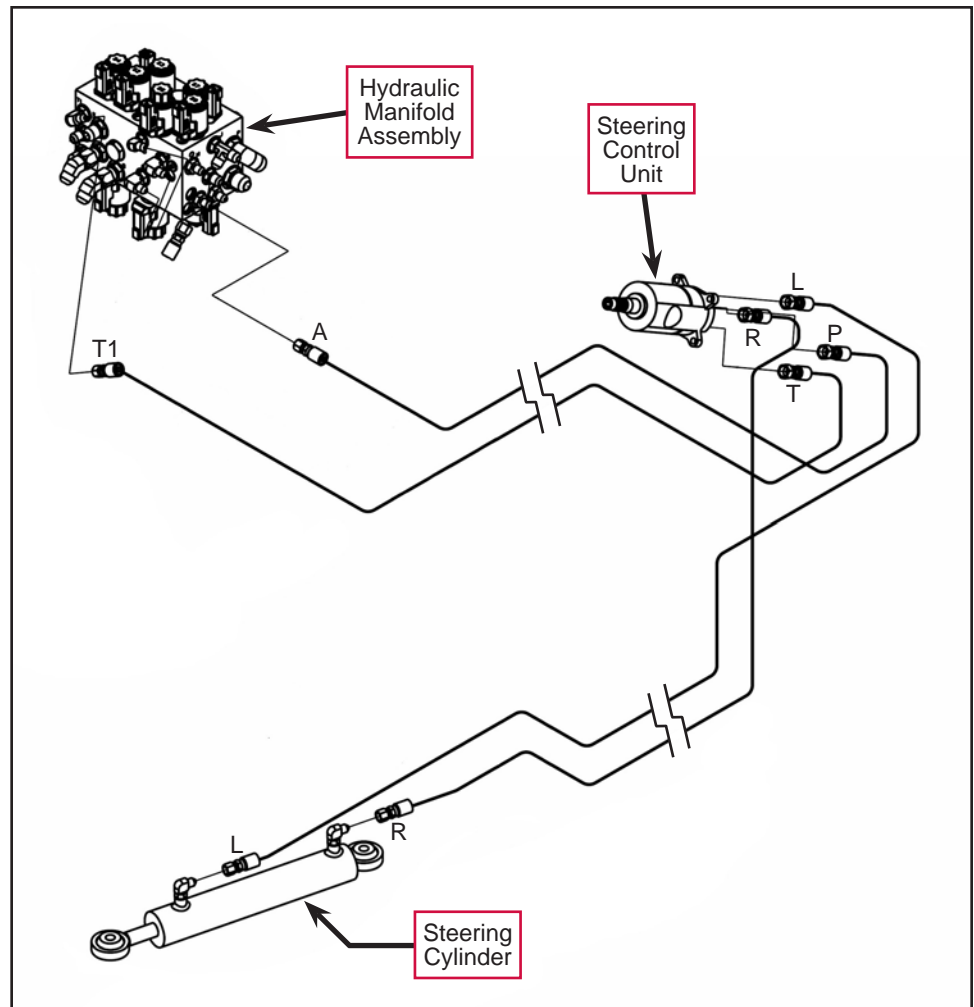

Hydraulic Diagrams

Steering Control Unit Description

The **Steering Control Unit** uses the input from the steering wheel to turn the drive wheel in the appropriate direction to steer the machine. When the Operator turns the steering wheel, the steering wheel shaft rotates the **Rotary Valve** and **Rotary Meter**, which are connected by a mechanical link inside of the **Steering Control Unit**.

- The direction in which the **Rotary Valve** moves determines which side of the **Steering Cylinder** receives the hydraulic oil to turn the drive wheel left or right. Note that when the Operator stops turning the steering wheel, the springs in the **Steering Control Unit** return the **Rotary Valve** to the neutral (closed) position to hold the **Steering Cylinder** rod in its current position.
- The number of degrees that the **Rotary Meter** rotates determines the volume of oil that the **Steering Cylinder** receives from the **Rotary Valve**. This allows the drive wheel to turn in proportion to the steering wheel rotation.

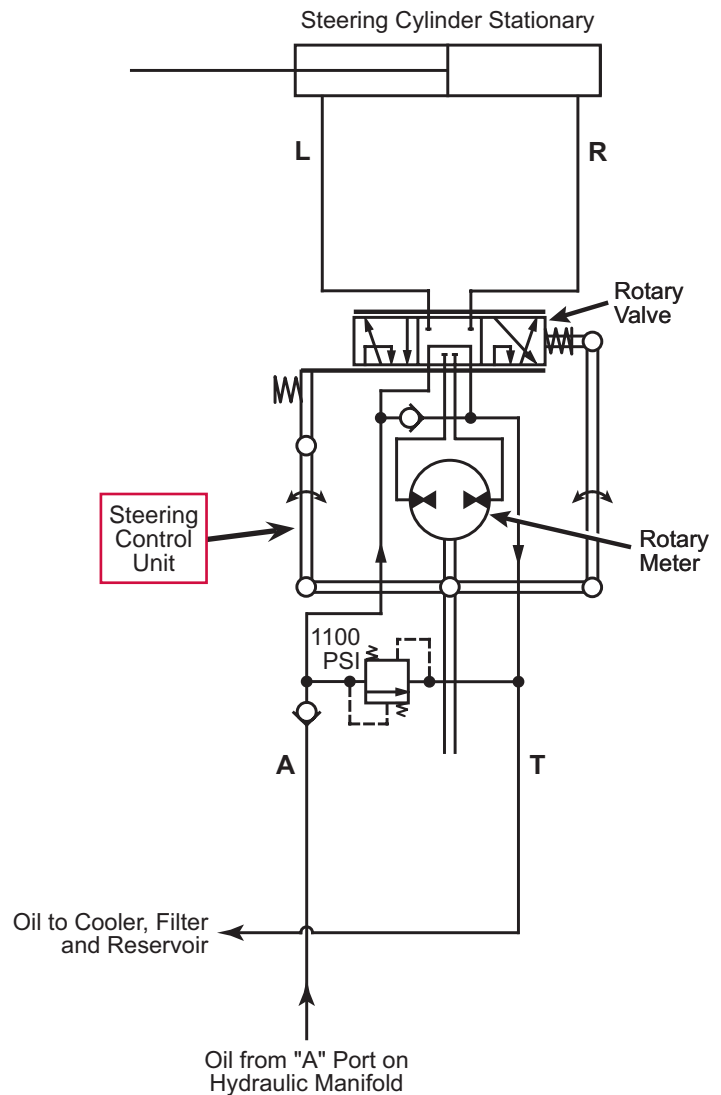

Steering Wheel Stationary

When the engine is running, the **Gear Pump** sends oil through the **2.0 GPM** flow divider in the **Hydraulic Manifold Assembly** to the “**A**” port on the **Steering Control Unit**. When the steering wheel is stationary, the **Rotary Valve** is in its neutral (closed) position. The hydraulic oil flows through the U-shaped ports in the **Rotary Valve**, through the “**T**” port on the **Steering Control Unit**, then to the **Oil Cooler** and **Filter**. Note that when the steering wheel is stationary, the **Rotary Valve** ports are blocked and the **Steering Cylinder** will maintain its current position.

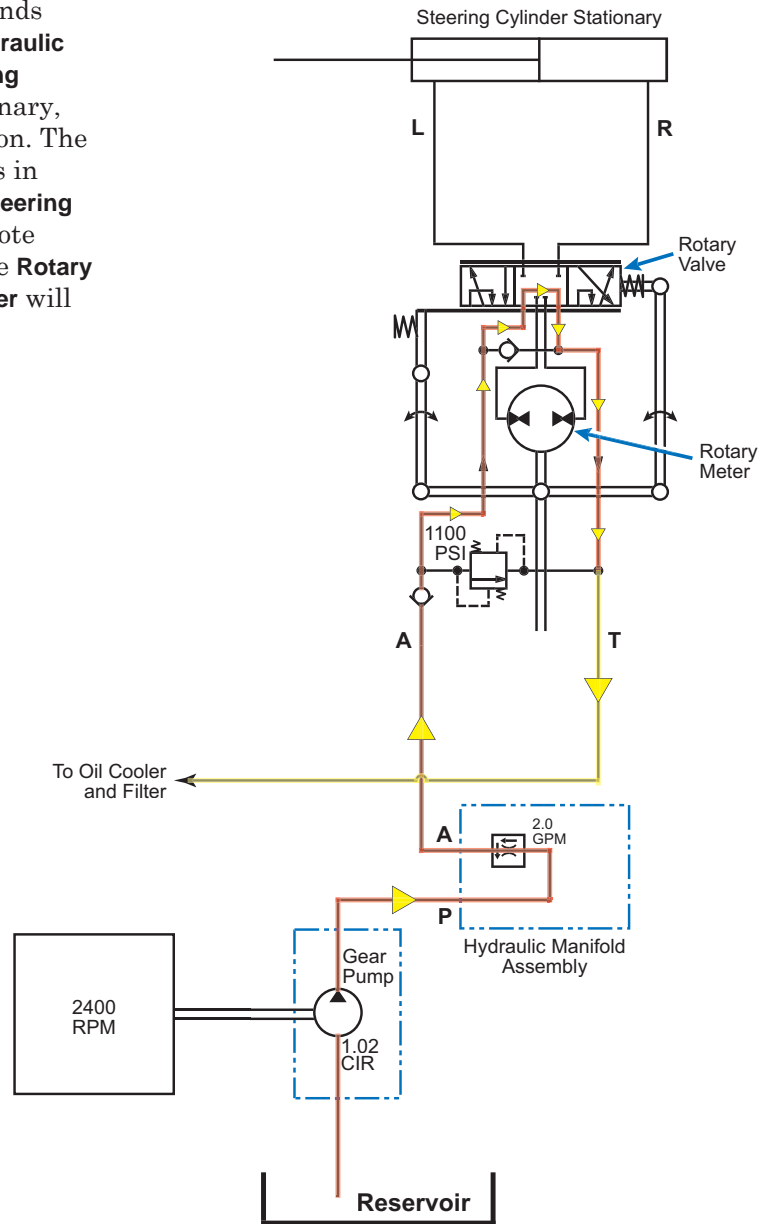

Steering Wheel Turned Toward the Right

When the Operator turns the steering wheel to the right, the **Rotary Valve** directs the hydraulic oil to the corresponding side of the **Rotary Meter**. The **Rotary Meter** sends the appropriate volume of oil to the **Steering Cylinder** corresponding to the amount of steering wheel rotation.

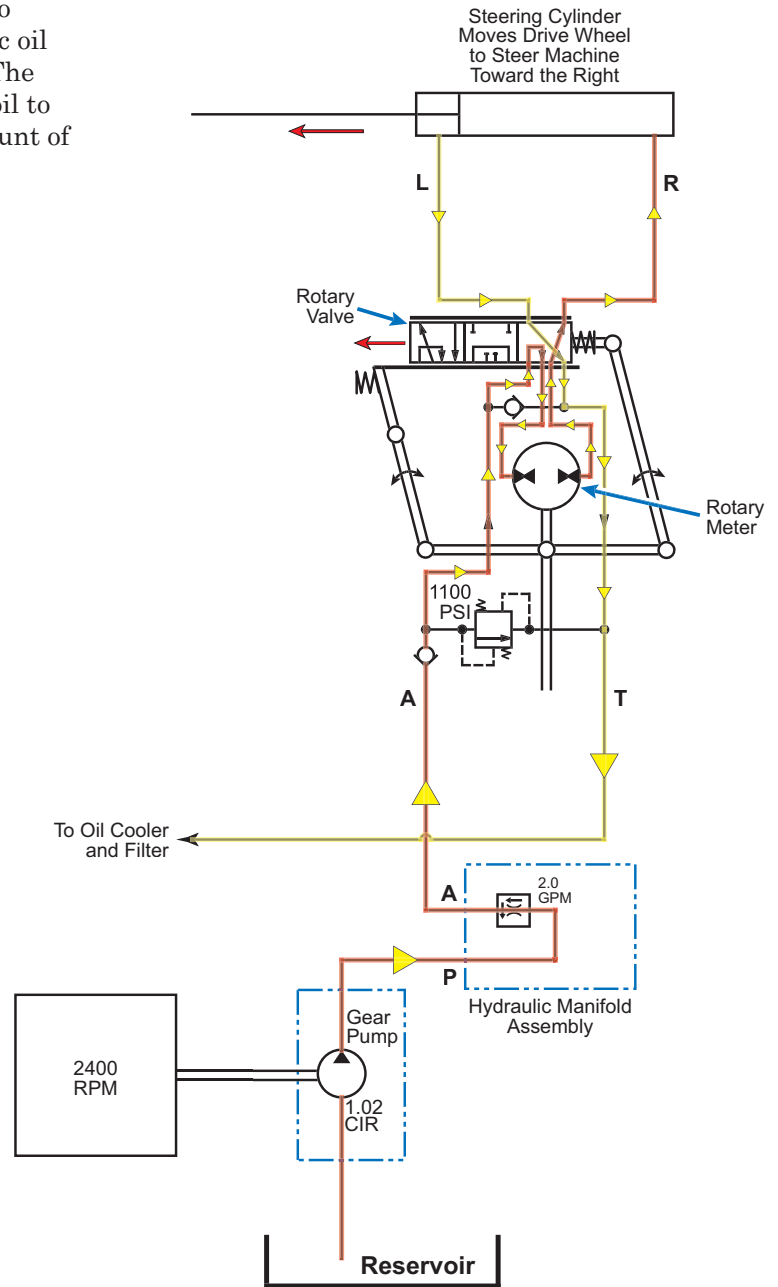

Steering Wheel Turned Toward the Left

When the Operator turns the steering wheel to the left, the **Rotary Valve** directs the hydraulic oil to the opposite side of the **Rotary Meter**. The **Rotary Meter** again sends the appropriate volume of oil to the **Steering Cylinder** corresponding to the amount of steering wheel rotation.

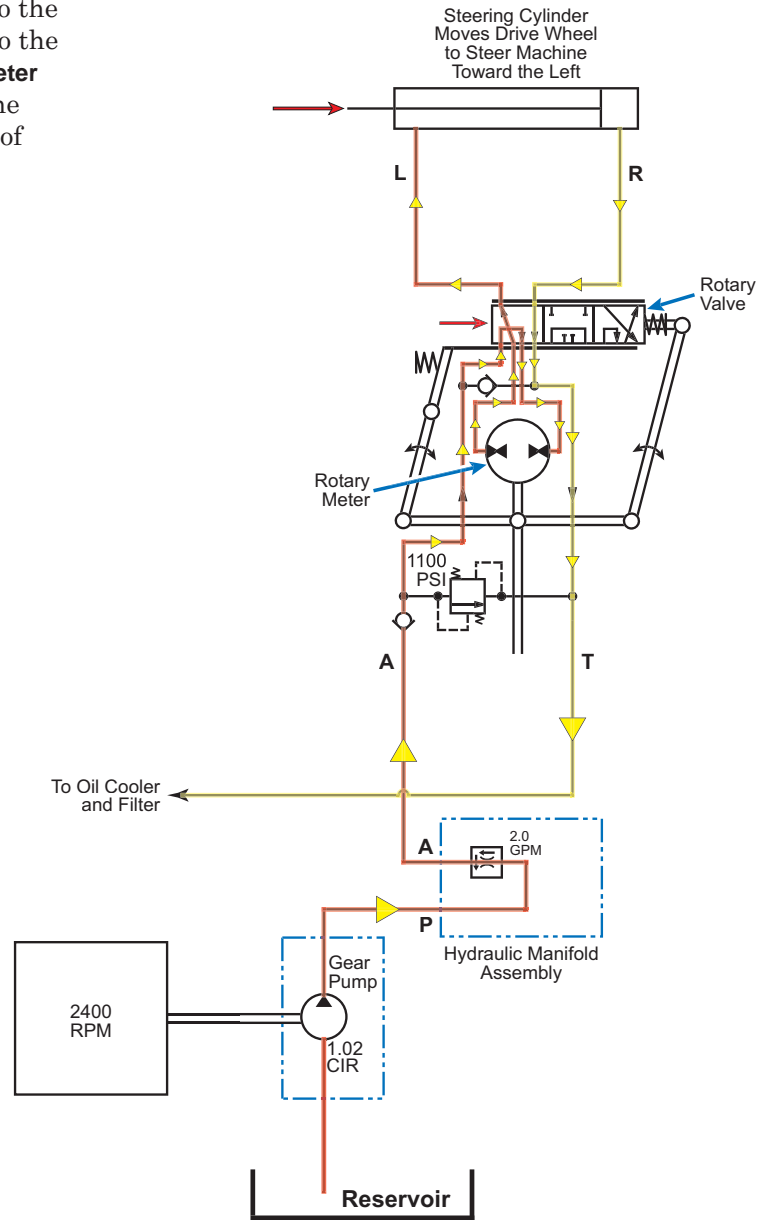

Steering Wheel Held in Full Right or Left Position

When the steering wheel is held to the stop in its full-right or full-left turn position (full-left is shown here), the **Relief Valve** opens up to allow the hydraulic oil to pass through the **Relief Valve** and to the **Oil Cooler** and **Filter**.

The **Relief Valve** will also open if something is preventing the drive wheel from rotating to steer.

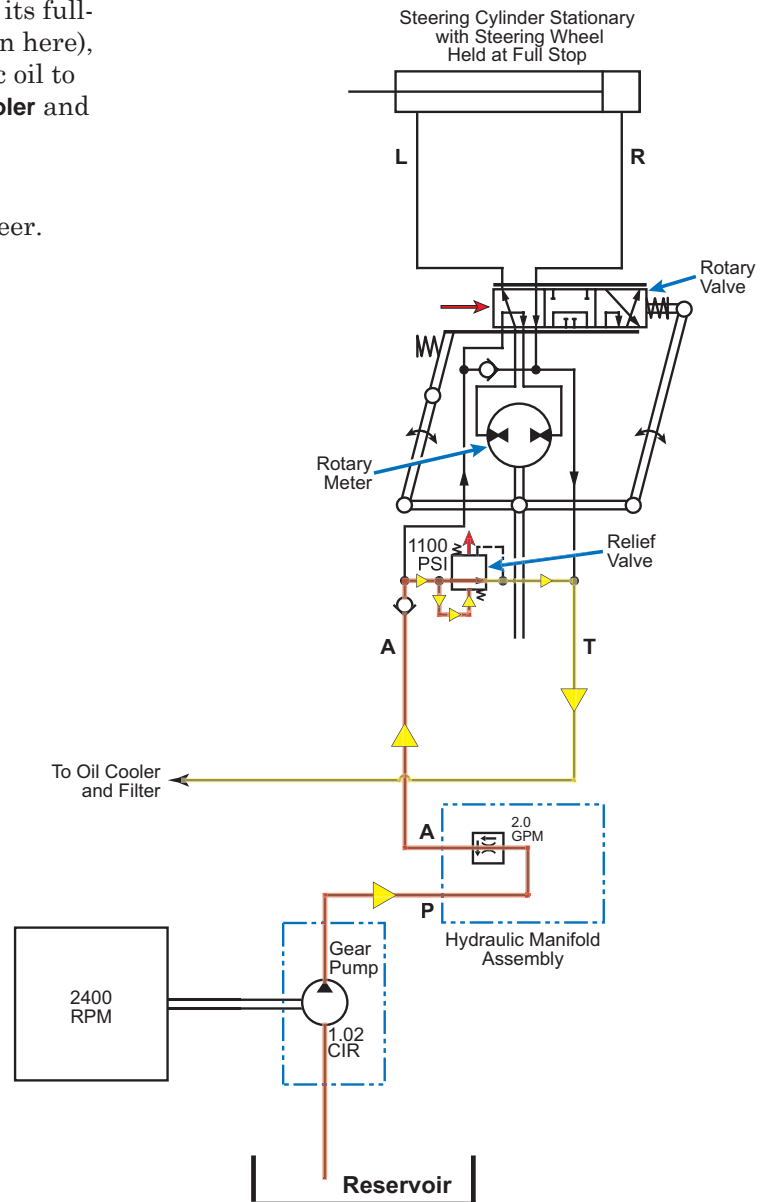

Turning the Steering Wheel with the Engine Off

When the engine is off and no hydraulic oil is being pumped to the **Rotary Valve** and **Rotary Meter**, the **Rotary Meter** acts like a pump when the steering wheel is turned. The **Check Valve** opens to allow the oil pumped from the **Rotary Meter** to flow to and from the **Steering Cylinder** to allow the machine to be steered manually with the engine off.

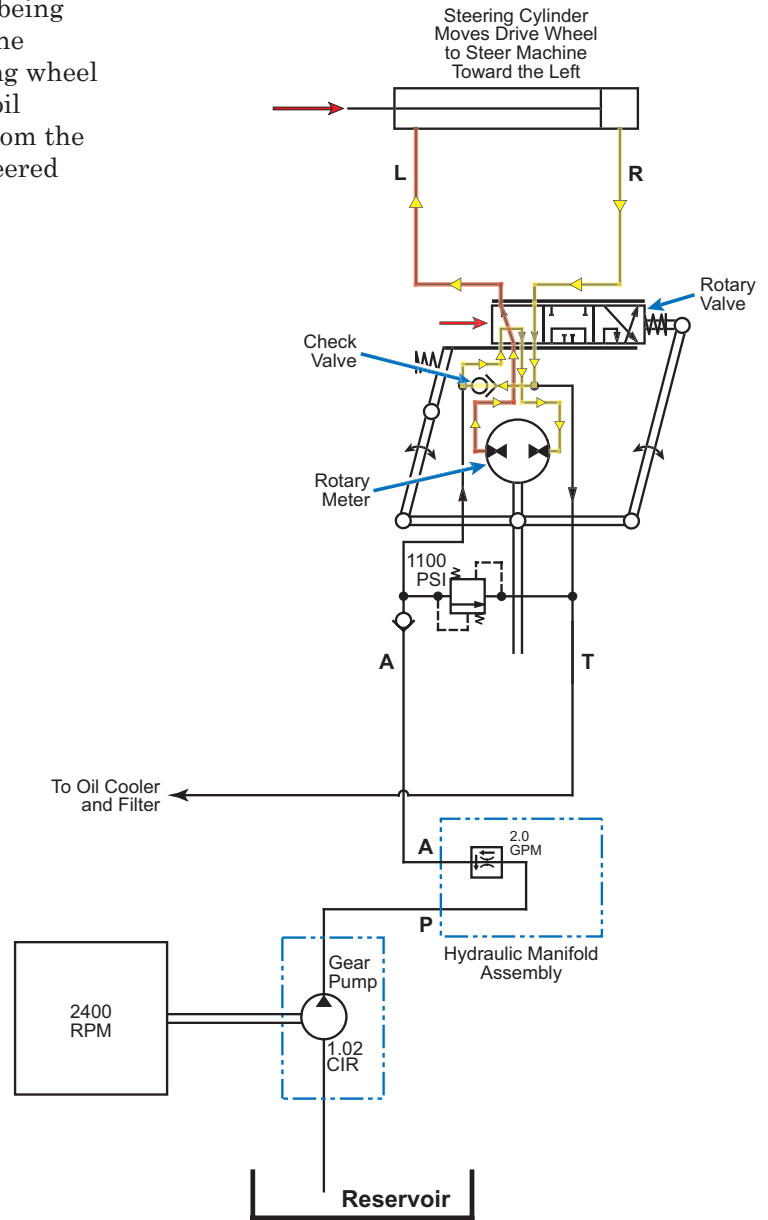

Component Locations

The following components are included in this section:

- Steering Wheel and Steering Control Unit
- Steering Cylinder

Steering Wheel and Steering Control Unit

The **Steering Wheel** rotates the splined shaft on the **Steering Control Unit** which controls the hydraulic oil flow to the steering cylinder.

The **Steering Control Unit** is mounted to the frame and is located underneath the **Steering Plate**.

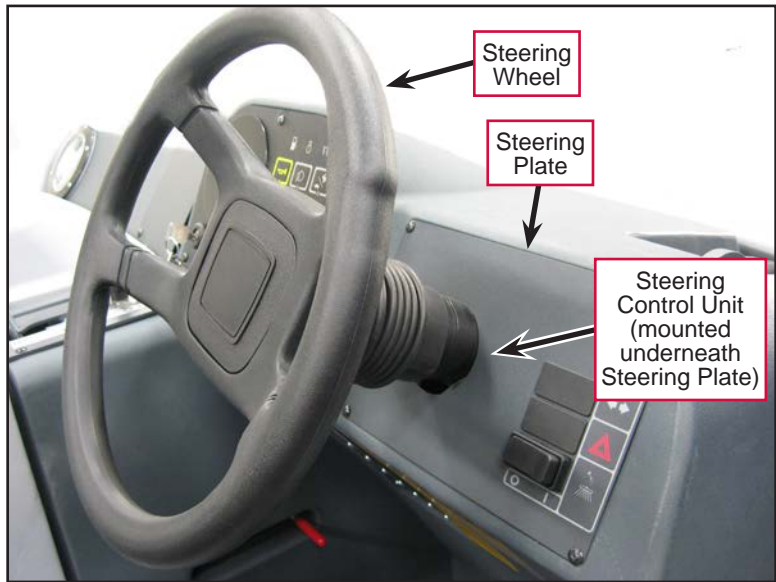

Steering Cylinder

The **Steering Cylinder** is located at the bottom rear of the machine and is connected to the machine frame and the **Drive Yoke Weldment**.

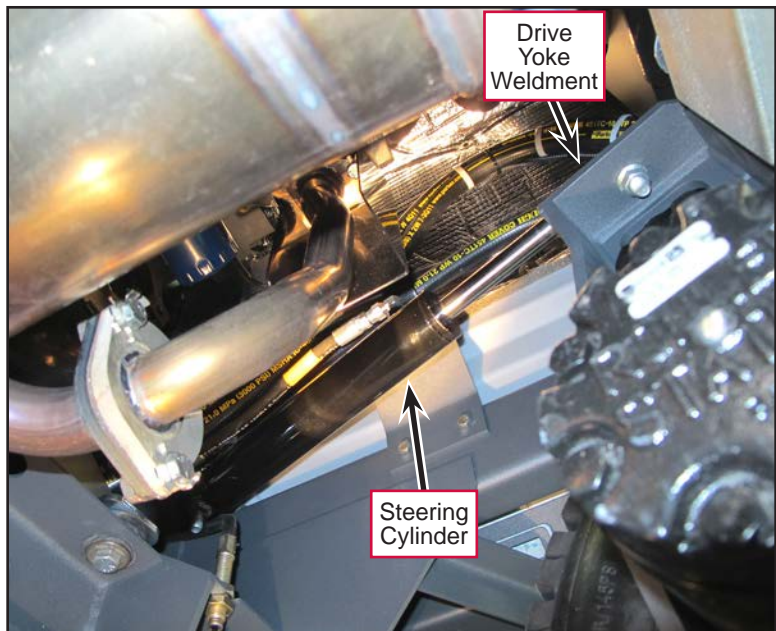

Drive Yoke Weldment and Steering Cylinder
as viewed from underneath the machine

Maintenance



Warning! Make sure the steering system and surrounding components are cool to the touch before attempting to grease the steering system components. Failure to observe this safety precaution can result in severe burns.

- Lubricate the steering **Bearing Cones** and **Bearing Cups** on the **Drive Yoke Weldment**.
- Lubricate the **Pivot Point** where the **Steering Cylinder** is attached to the **Drive Yoke Weldment**.

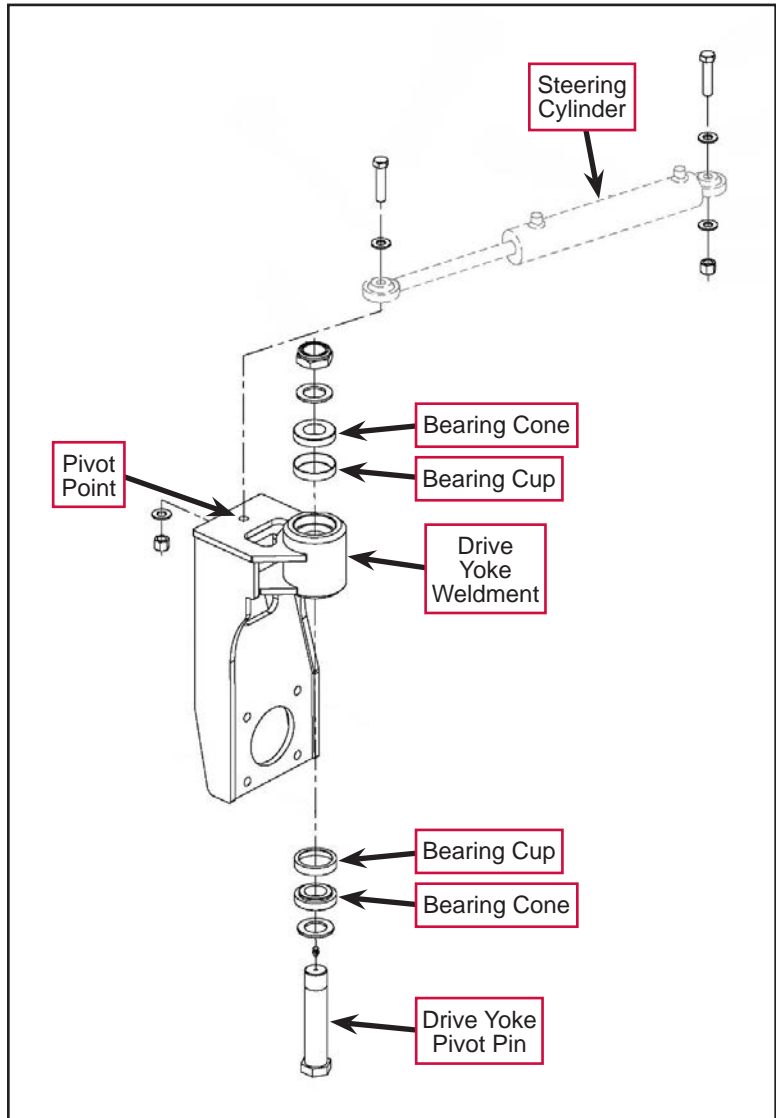

Troubleshooting

Problem	Cause	Correction
The steering is hard or “jerky”.	Not enough oil to the steering system	Check the pump output and correct as necessary. Check the priority flow divider and correct/replace as necessary.
	There is binding at the steering cylinder mounting points.	Check the steering cylinder mounting points and lubricate/repair as necessary.
	There is binding in the drive yoke weldment, bearing cups, bearing cones or drive yoke pivot pin.	Check the drive yoke weldment, bearing cups, bearing cones and drive yoke pivot pin and lubricate/repair as necessary.

Specifications

Component	Specifications
Steering	Rear wheel, hydraulic cylinder and rotary valve controlled
Steering Control Unit	Maximum Pressure on Connections
	P – 1,813 psi [125 bar]
	T – 290 psi [20 bar]
	R and L – 2,610 psi [180 bar]
	Recommended Oil Flow – 1.9-5.3 GPM [7-20 LPM]
	Displacement – 4.88 CIR [80 cm ³ /Rev.]
Check Valve for Manual Steering – Yes	
Relief Valve – 1100 psi [75.8 bar]	

Sweep System, Main Broom

Functional Description

The hydraulically powered main broom is used to sweep dry debris into the hopper. It can be operated with or without the dust control function, and with or without the side brooms being used.

Circuit Description

Most control circuits are fairly straight forward with the controller completing the electrical circuits to ground. The main broom is activated (lowered and spinning) when the control panel energizes the S2 Main Broom Enable valve. The control panel will energize the S2 solenoid only when the following conditions are met:

- The engine is running with the Engine Speed Switch set to full throttle.
- The hopper is properly seated. (The S4 Hopper Interlock switch is closed to ground to indicate the hopper is properly seated.)
- The Main Broom Lever is in the Sweep (Down) or Full Float position.
- The Drive Pedal is activated.

The electrical (and hydraulic) circuitry related to the main broom is shown in the following simplified diagram, and explained on the following page.

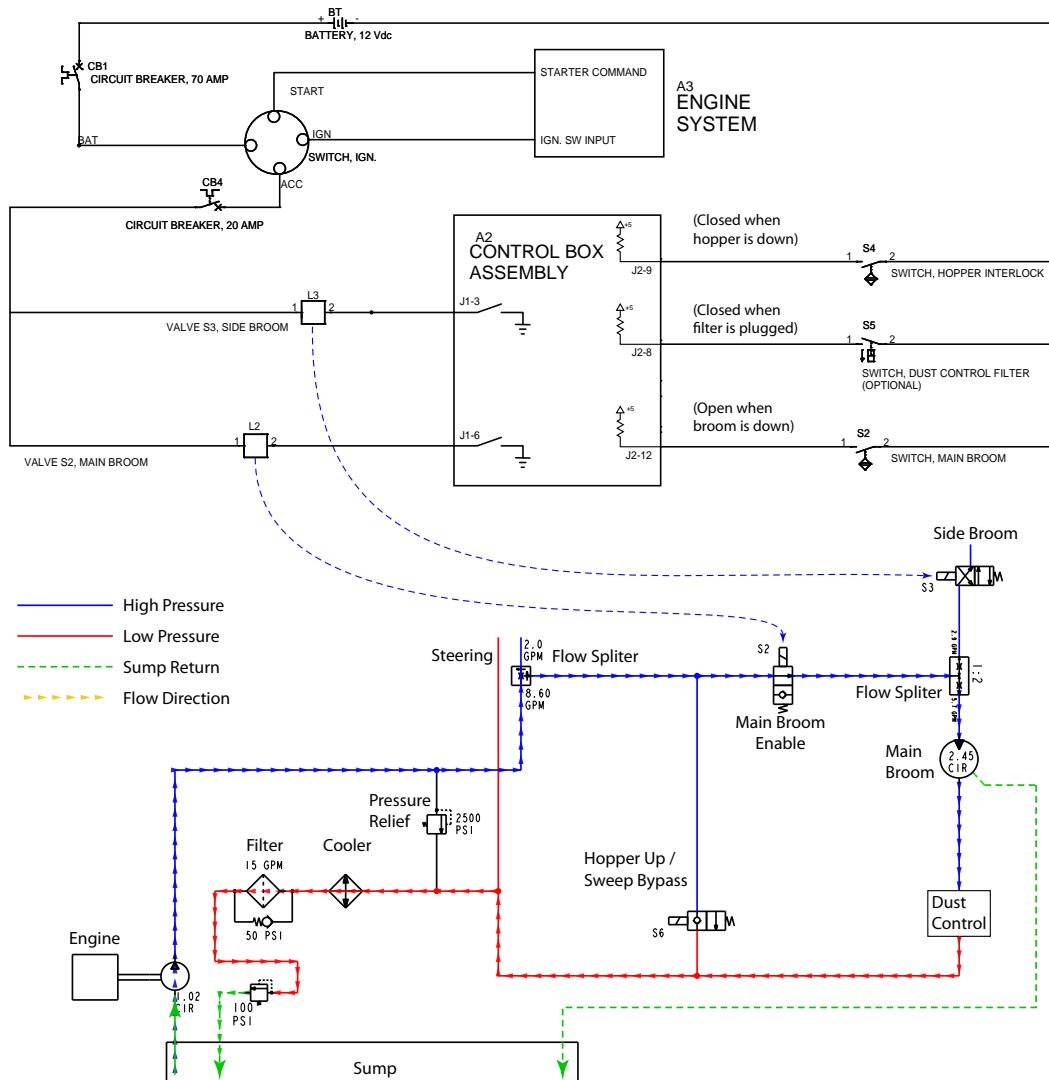

Hydraulic Operation

The hydraulic system is controlled by two solenoid valves, which are themselves, controlled by the main machine controller. The solenoids are active when the main machine controller sets the output to a low voltage (connects the output to ground).

- The Bypass solenoid valve (S6) is “normally open”, meaning that fluid flows through it when the solenoid is not active. This provides a low resistance path for hydraulic fluid back to the reservoir when no downstream hydraulics are being used. This solenoid valve is active (fluid flow blocked) any time the main hydraulics related to the sweeping system are required. This includes raising the hopper or any of the broom and dust control hydraulics. If this valve fails to energize (block flow), then the sweep system will either not function at all, or function very slowly.
- There are two flow splitters in the system. The 2.0/8.6 gpm splitter requires 2.0 gpm, minimum, to flow to the steering system as a priority, and up to 8.6 gpm flow to the rest of the sweep system. The 2.9/5.7 gpm splitter is a 2:1 ratio splitter at any flow rate.
- When the main broom is on, the Main Broom solenoid valve (S2) is active (fluid can flow through), and the Bypass solenoid (S6) is active (blocking fluid). Hydraulic fluid flows through the Main Broom motor and through the Dust Control system. (The dust control system contains a bypass valve so that fluid will always be available to flow regardless whether the vacuum motor is active or not.)
- The Main Broom motor contains a case drain. The case drain is not normally part of the hydraulic circuit, but it permits excess and leakage hydraulic fluid to return to the sump, and prevents damage to the motor case in the event that the motor’s case were to become pressurized.

Component Locations

The diagram below shows component locations for some components related to the main broom system.

- Idler Arm
- Broom Controls
- Main Broom
- Broom Motor
- Main Broom Switch
- Hydraulic Valves

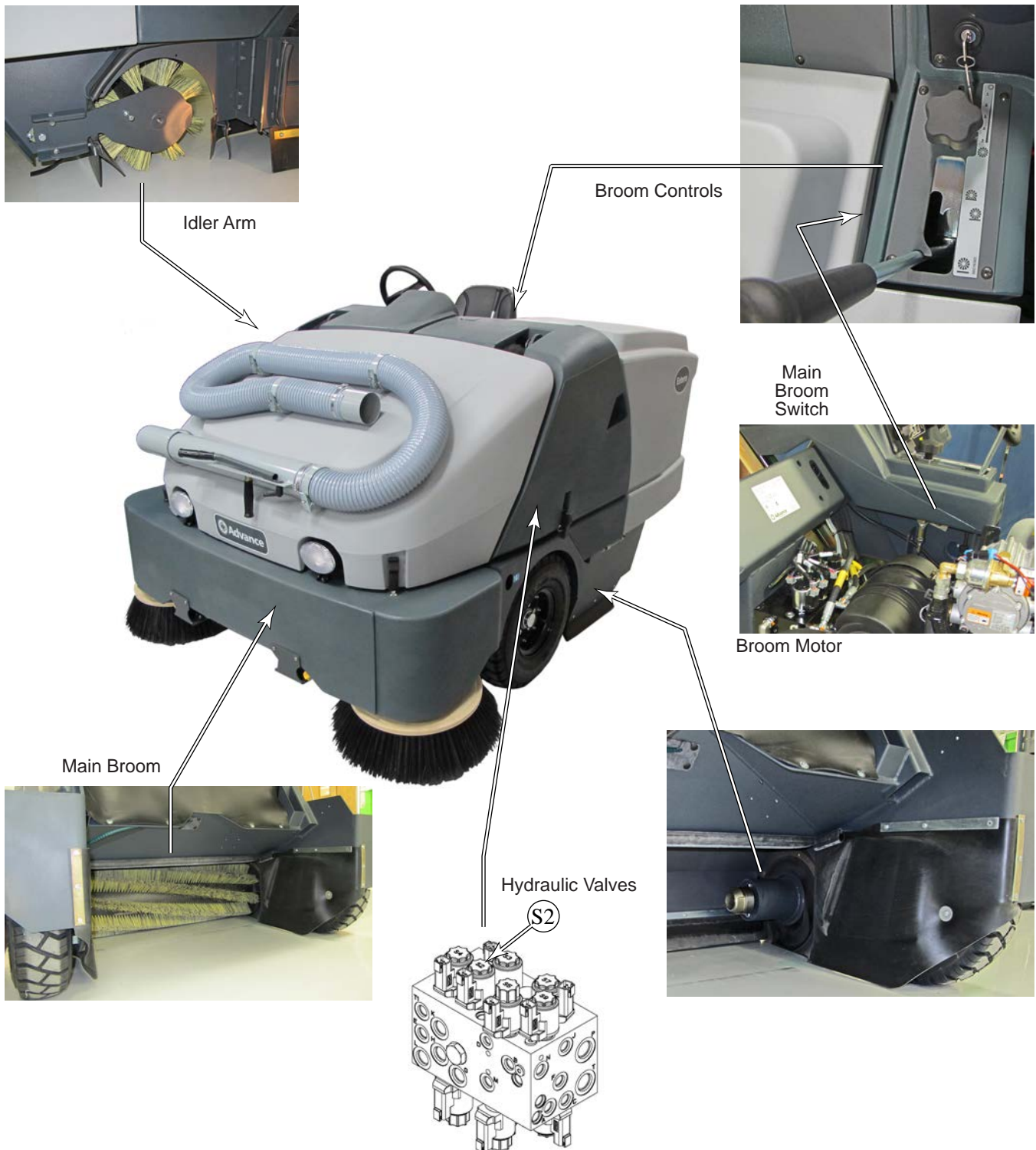

Maintenance and Adjustment

When the machine is not in use, the main broom should be in the raised position to prevent flattening and curling of the bristles.

Cleaning and Inspecting the Main Broom

Inspect and clean the main broom whenever it is removed for rotation, or if sweeping performance is reduced when the hopper is not full. Remove any twine or other materials that are wound around the broom cylinder or any other debris that prevents good contact between the broom bristles and the cleaning surface.

Rotate or Replace the Main Broom

Because the Main Broom Motor always turns in the same direction, the bristles on the broom will eventually become curved opposite of that rotation. Sweeping performance can be improved by removing the broom and turning it around (end-for-end). This procedure, known as “rotating” the main broom, and should be performed every 15 hours of operation.



Note: This procedure does not apply to the optional chevron broom, because that broom has directional bristles.



Caution! Broom bristles may be sharp. Wear gloves to protect your hands when handling the broom.

1. Turn the Ignition Switch to Off.
2. Put the Main Broom Lever in the Up position.
3. Open the broom access panel (2).
4. Pivot the idler arm (3) away from the main broom core.
5. Pull the Main Broom (1) off the motor shaft and out of the machine.
6. Remove any string or wire wrapped around the broom. Also inspect the skirts at the front, back, and sides of the broom housing. The skirts should be replaced or adjusted if they are torn or worn to a height of more than 1/4 inch (6.35 mm) off the ground.
7. Turn the broom around (end-for-end) and slide it back into the broom housing. Make sure that the lugs on the broom core engage the slots in the broom drive hub and that the broom is fully seated.
8. Swing the idler arm back into the broom core. Make sure the lugs on the idler arm engage the slots in the broom core.
9. Close and latch the broom access panel.

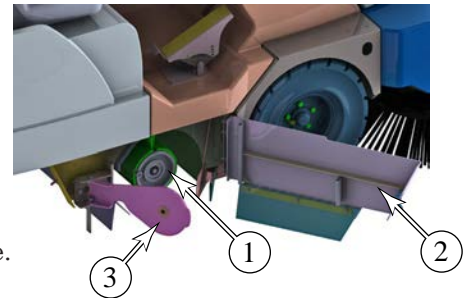

Inspect and Adjust the Broom Height

The main broom has 2 operating positions; Float (7) and Sweep (6). In the Float position, the height is left uncontrolled (floating) and the pressure on the broom is primarily determined by the weight of the mechanism. Due to the weight of the mechanism, operating the broom in Float mode for extended periods can result in excessive wear of the broom. In Sweep mode, the height of the broom is limited by the adjustment knob (4) to reduce wear on the broom.

The main broom adjustment knob (4) must be re-adjusted as bristle material is worn down and when the broom is replaced. Determining whether the broom height needs to be adjusted involves examining the contact area under the broom.

1. Drive the machine to an area with a level floor and set the parking brake. (Preferably an area with a dirty floor that will show contact from the spinning broom.)
2. Leave the engine running.
3. Move the Main Broom Lever (5) forward to the Sweep position (6).
4. Without actually moving the machine, lightly press the drive pedal out of the neutral position just enough to engage the broom. This allows the broom to polish a “strip” on the floor.
5. Raise the broom, release the parking brake, and move the machine so that the polished strip is visible.
6. Inspect the polished strip on the floor. The target width is between 2 and 3 inches (50 to 80 mm).
 - If the strip is less than 2 inches (50 mm) wide, lower the broom by loosening the knob (4) and sliding it forward.
 - If the strip is more than 3 inches (80 mm) wide, raise the broom by loosening the knob (4) and sliding it back towards you.
7. Repeat the procedure to verify the settings.

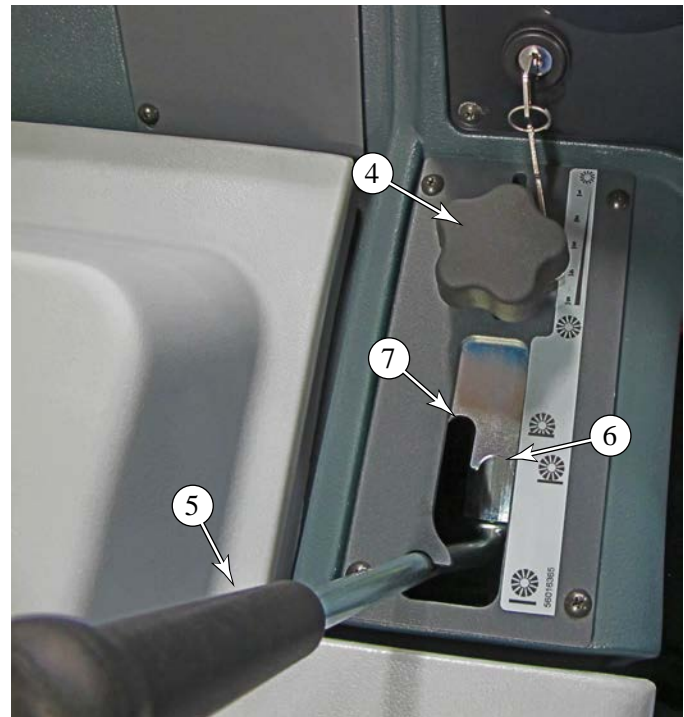

Inspect Housing Skirts

Visually inspect the skirts when rotating or replacing the main broom. The skirts should be replaced or adjusted if they are torn or more than 1/4 inch (6.35 mm) above the floor.

Troubleshooting

Main Broom Motor Will Not Run

Perform all testing with the engine running at operating speed, the main broom lowered (Sweep position), and the drive pedal activated (the machine moving). The main broom magnetic switch S2 must be open and the hopper interlock switch S4 must be closed for the main broom system to run.

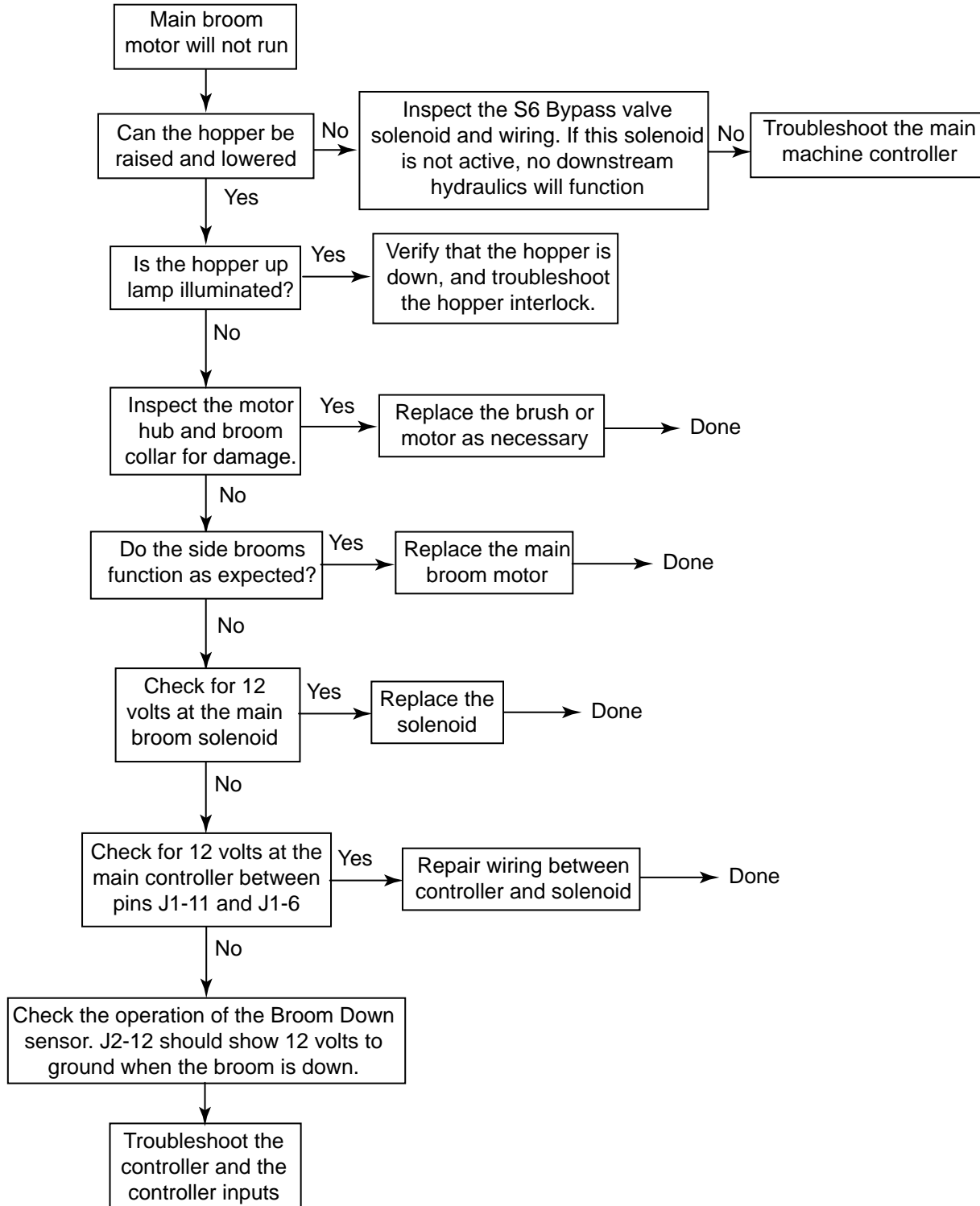

Specifications

Solenoid Coil Resistance Values

Solenoid Coil	Normal Resistance Value
S2 coil	8 ohms
S6 Coil	8 ohms



Sweep System, Side Broom

Functional Description

The side broom sweep system consists of one or two hydraulically driven rotating brooms at the front corners of the machine. The brooms direct debris to the center of the machine where it can be picked up by the main broom and deposited in the hopper. The brooms are raised and lowered by hydraulic actuators.

Circuit Overview

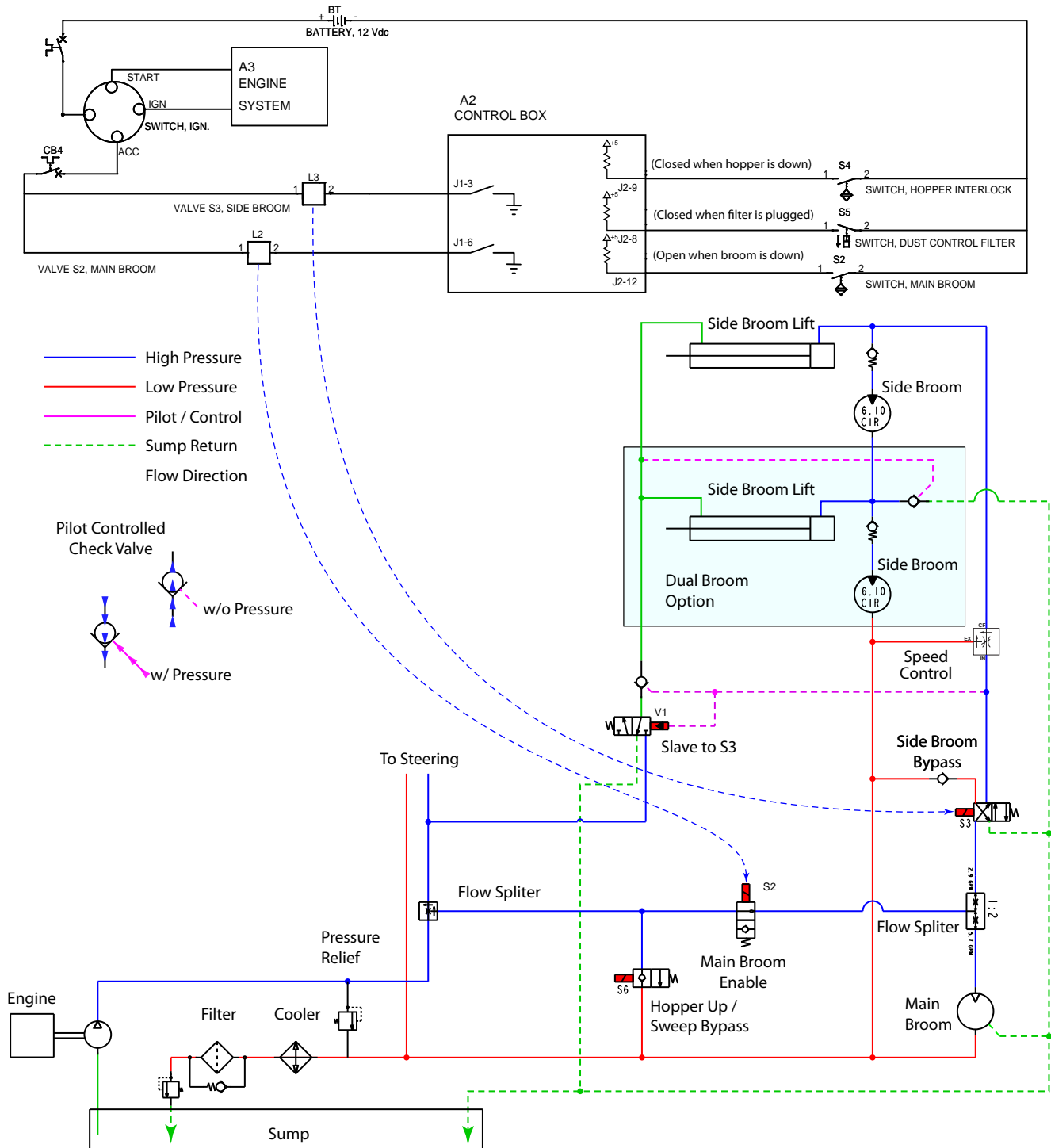

Electrical Circuit

Most electrical control circuits are fairly straight forward with the controller completing the electrical circuits to ground. The controller will not activate the side brooms unless the main broom is active (and all other prerequisites to that function are also true).

Hydraulic Circuit, Brooms Off

When the side brooms are not active, the lift cylinders are held in the lifted state and no fluid flows to the motors. The hydraulically controlled valve V1 is in the inactive state because S3 is also inactive, and no hydraulic pressure is present on the control circuit. This also sets the pilot controlled check valve C2 inactive, so it functions as a normal check valve. This check valve keeps the brooms in the lifted state even if the hydraulic system is shut down.

Piloted check valve C1 is active, and this allows fluid to pass backward through the check valve to drain excess fluid from the second (optional) lift cylinder. Excess fluid from the first lift cylinder flows through the inactive S3 valve to return to the sump.

In the event that the main broom is running without the side brooms, the S3 valve also contains a side broom bypass circuit to permit excess fluid not needed by the main broom to return to the low pressure return line.

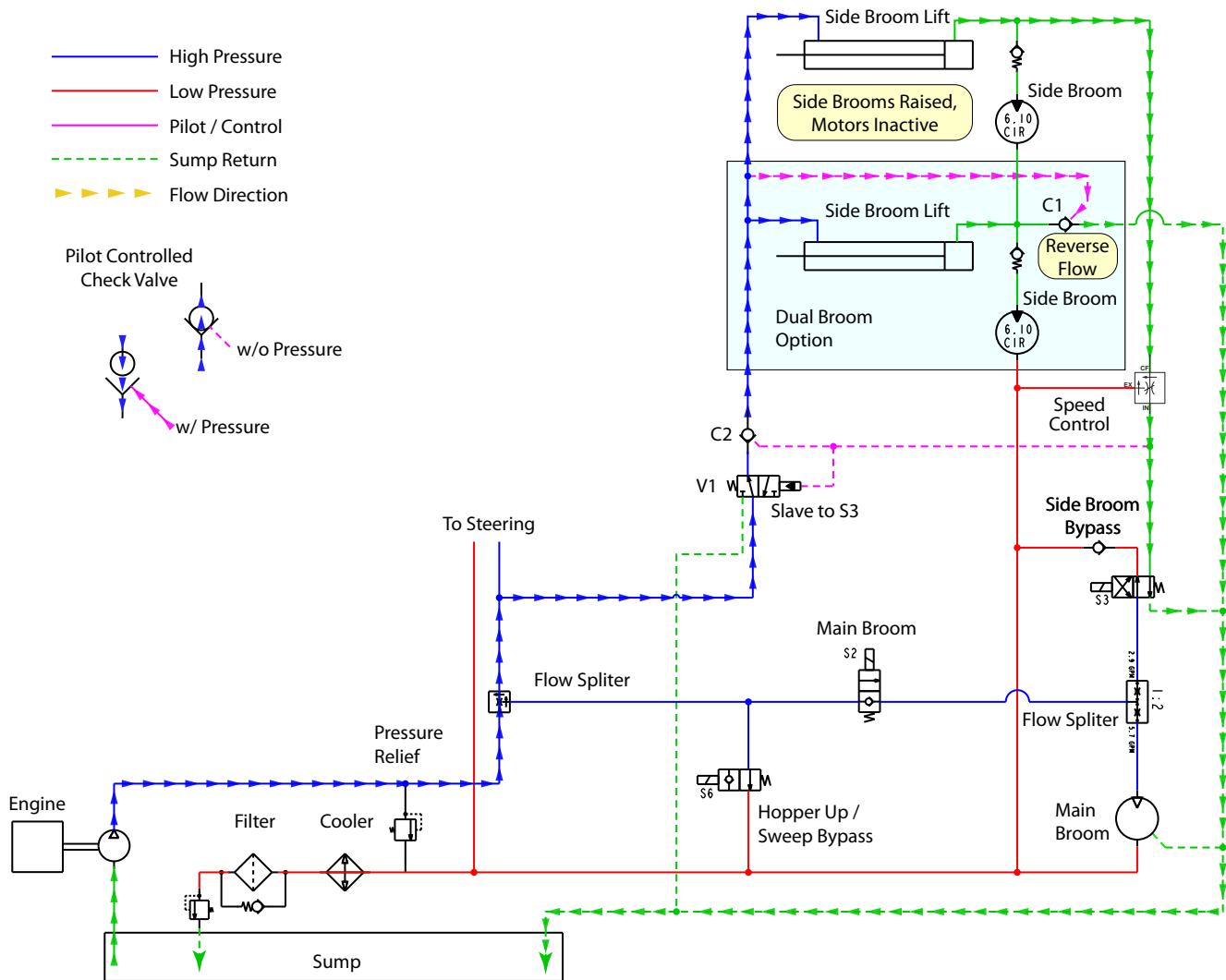

Hydraulic Circuit, Brooms On

In order for the side brooms to operate, the main broom must be running. The S2 solenoid is energized to allow fluid to flow to the splitter between the main broom and the side broom circuits. The side broom solenoid (S3) is energized to allow fluid to flow into the side broom circuit. This also energizes the piloted control line for V1 and C2 to allow excess fluid to leave the side broom lift cylinders so they can be lowered.

If equipped with the optional side broom speed control, fluid flows through the variable flow regulator, and any excess flow not needed for the set speed will return through the low pressure return line.

The two side brooms are connected in series. At the first broom, fluid activates the cylinder to lower the broom and flows through the broom motor. The fluid exiting that motor then passes to the second (optional) side broom before returning through the low pressure return line.

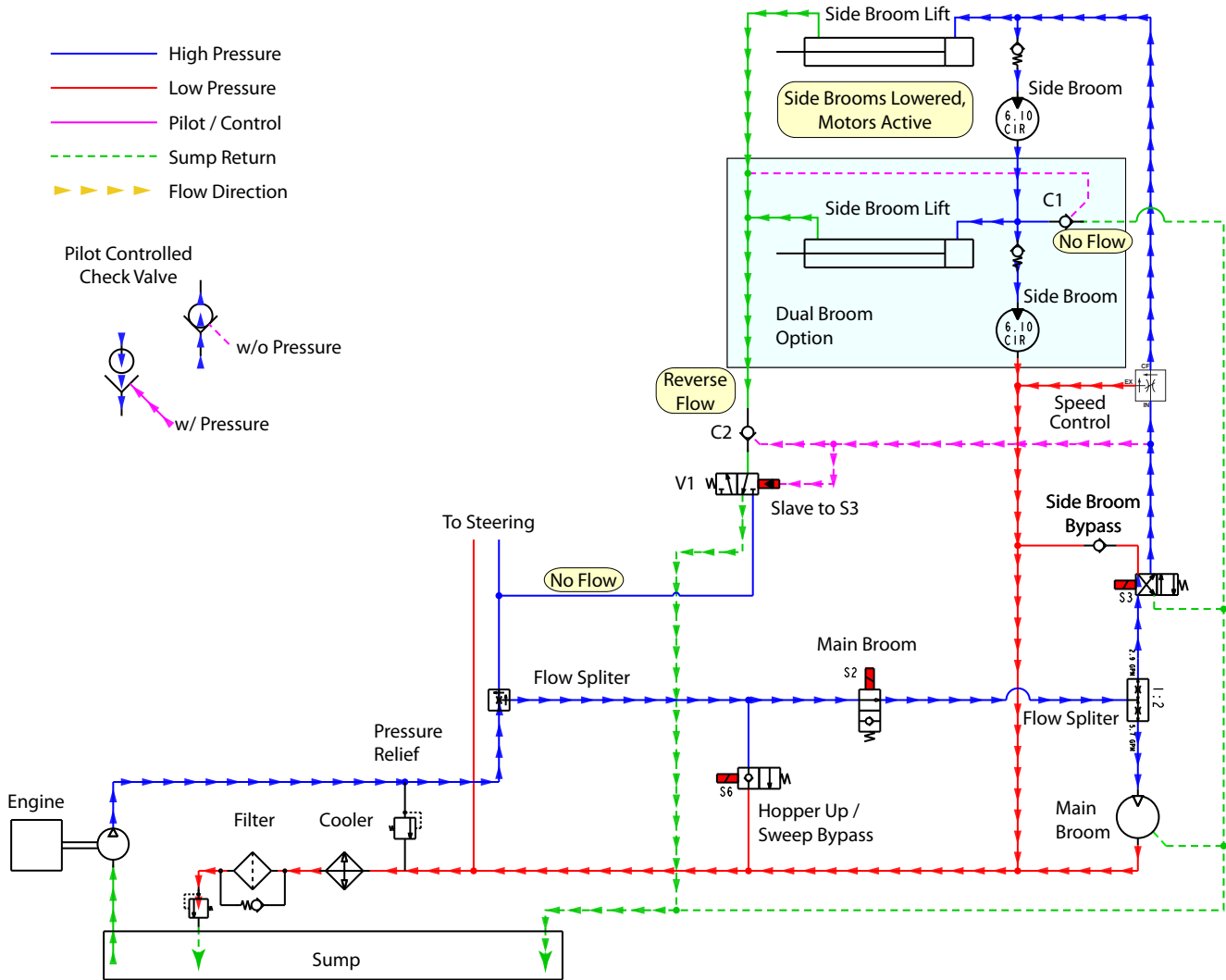

Component Locations

The diagram below shows the location of the side broom motor, lift cylinder, and hydraulic valves.

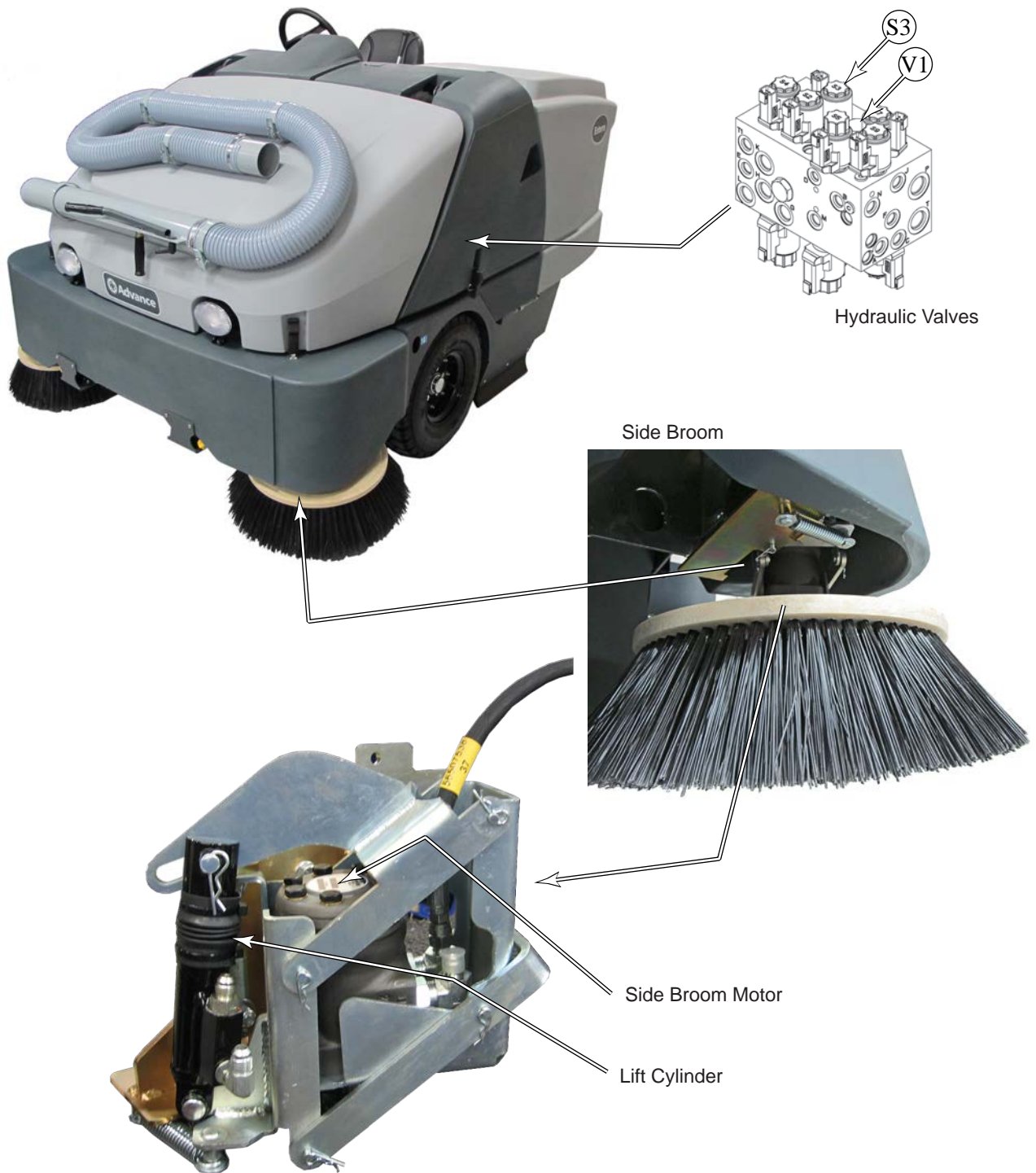

Troubleshooting

Side Broom Won't Run

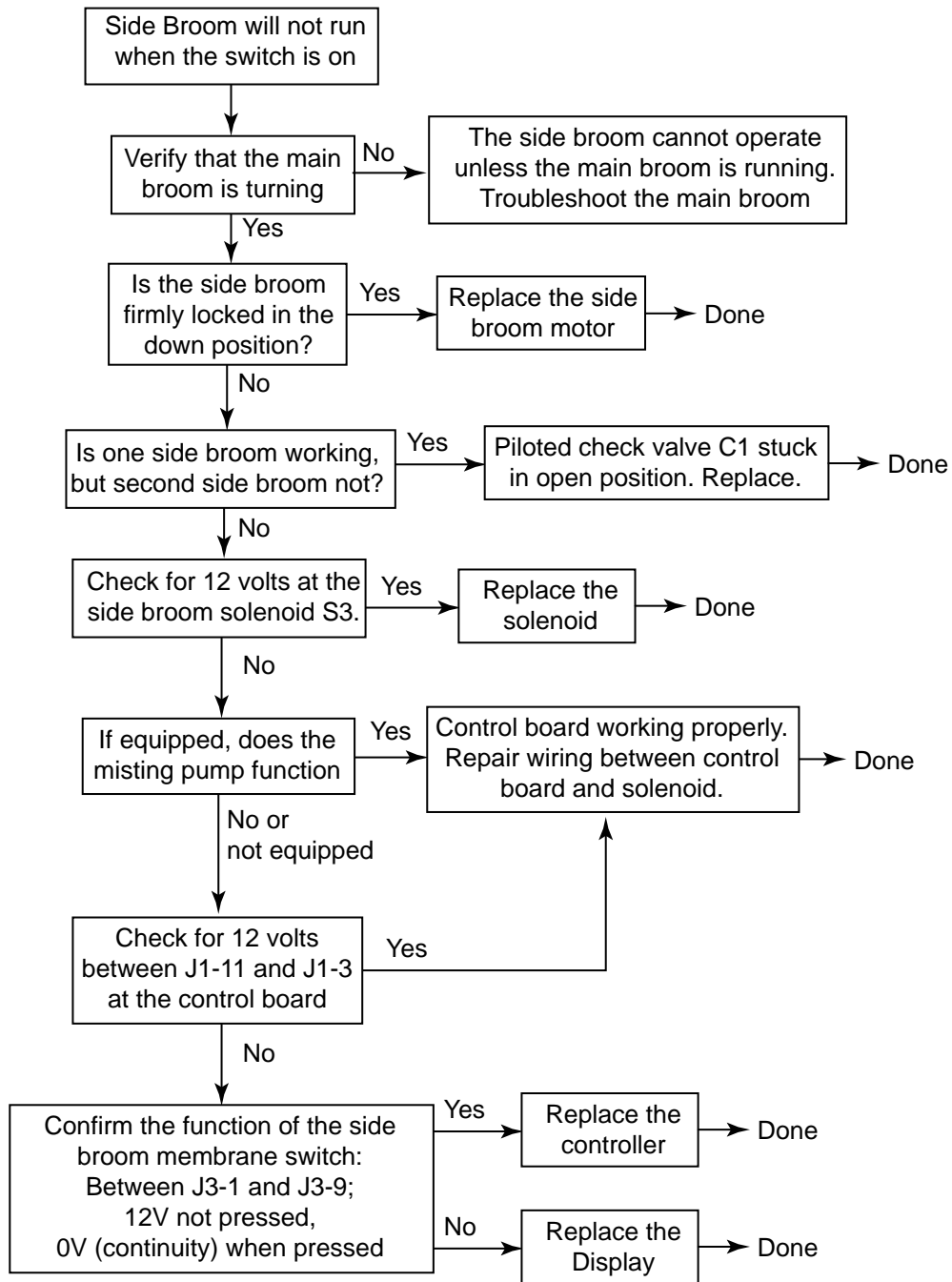

Side Broom Won't Raise

If the side broom stops rotating but won't raise, that is indicative of a hydraulic problem with the pilot controlled valve V1. If the side broom won't raise and also continues to rotate (with main broom running), that may be either a stuck S3 solenoid or an electrical problem.

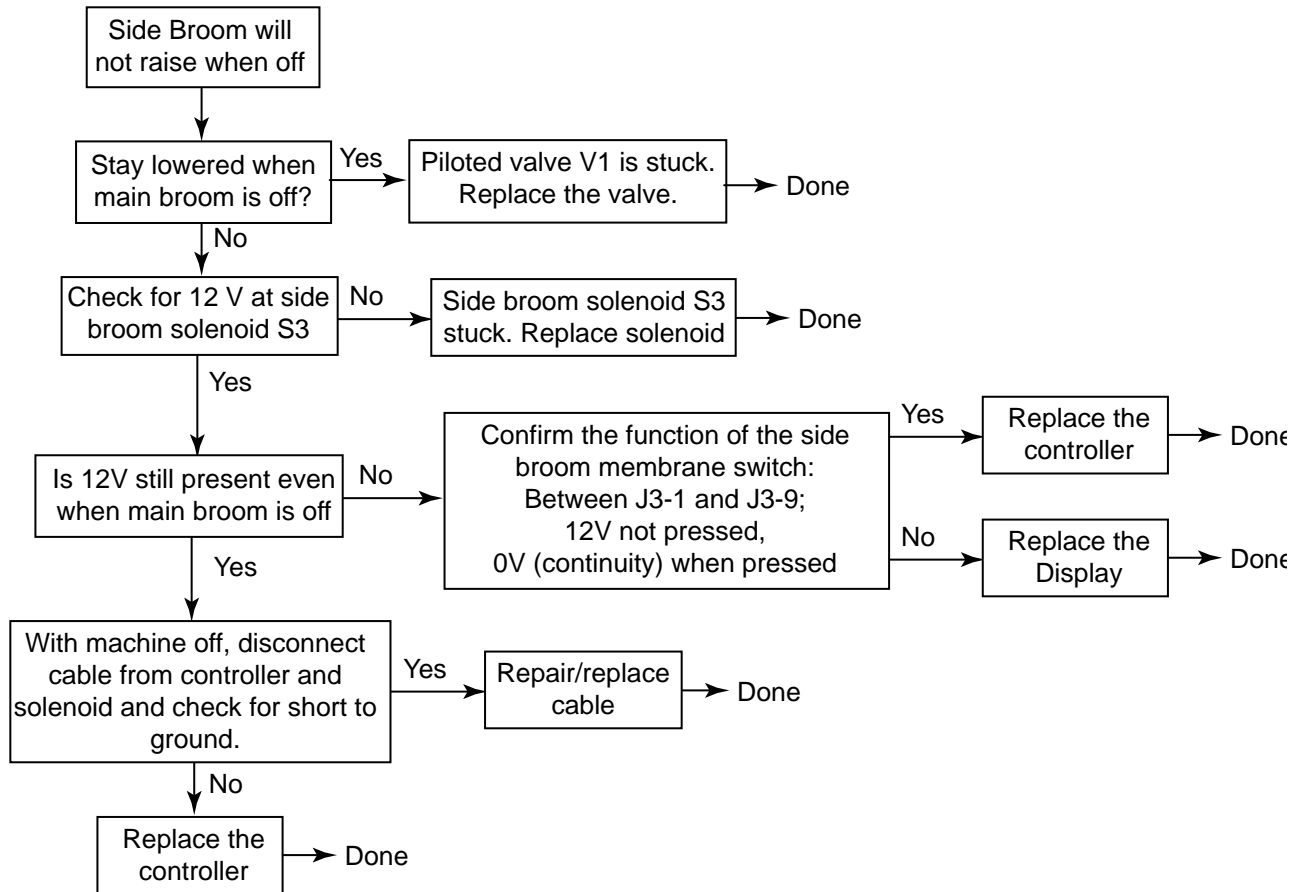

Side Broom Won't Lower

If the side broom rotates but will not lower, that is an indication that high pressure hydraulic fluid is present at both ports of the lift cylinder at the same time. The pilot controlled valve V1 is stuck.

If the side broom neither rotates nor lowers, then use the [Side Broom Won't Run](#) troubleshooting procedure described on page 195.

Specifications

Parameter	Nominal Resistance
Side Broom Solenoid resistance	• 8 Ω

Wheel System, Non-Traction

Functional Description

The non-traction wheels support the front of the machine and house the machine brakes. The wheel system includes the Wheels, Brake and Spindle Assemblies and the various mounting hardware. The wheels are mounted in the wheel wells on the front sides of the machine, between the main broom cover panels and the side brooms.

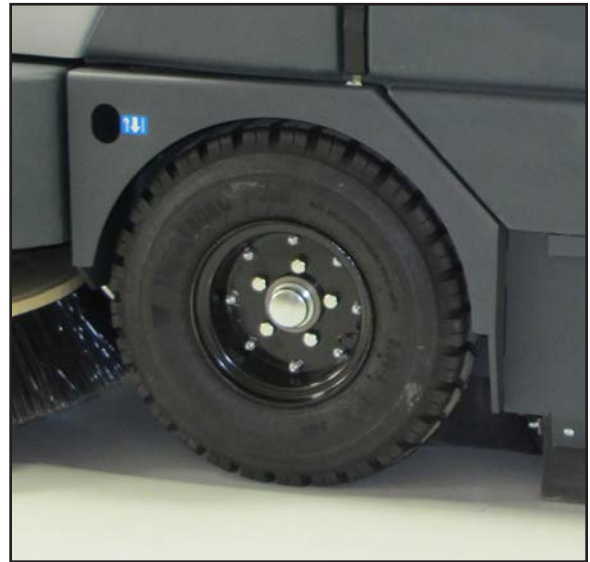

Maintenance and Adjustments



Warning! Before performing any maintenance or adjustments, make sure the key switch is off and the key is removed from the machine. Chock the machine wheels to prevent the machine from moving.

Troubleshooting

Problem	Cause	Correction
The wheels are making excess noise.	The wheel bearings are worn.	Check the wheel, wheel bearings, brake and spindle assembly and replace as required.
	The wheel and/or brake and spindle assembly are damaged.	
The brakes are not working correctly.	The brakes are out of adjustment	Adjust the brakes.
	The brake linings are worn out.	Replace the brake linings.

Removal and Installation



Warning! Before performing any maintenance or adjustments, make sure the key switch is off and the key is removed from the machine. Chock the machine wheels to prevent the machine from moving.

- Never work under a machine without safety stands or blocks to support the machine. When jacking the machine, do so at the designated Tie Down/Jacking Locations.

To Remove and Reinstall a Wheel

The Wheels are held onto the Brake and Spindle Assemblies with 5 lug bolts. The Brake and Spindle Assemblies are fastened to the machine frame with 1/2”-20 Hex Screws.

1. Jack up the machine at a designated jacking point.
2. Install safety stands or blocks to support the machine while you work on it.
3. Remove the five lug bolts that secure the wheel.
4. Repair or replace the wheel assembly.

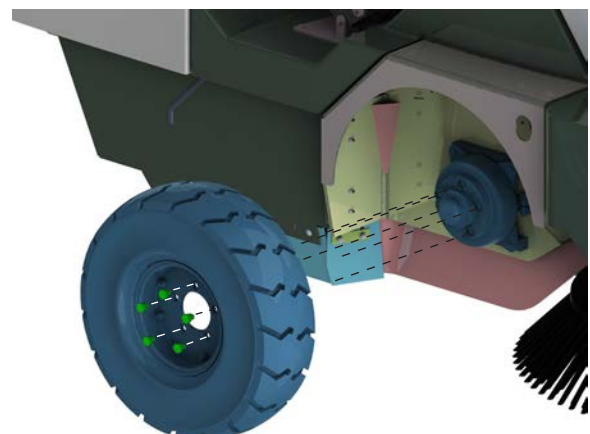

5. Place the wheel on the spindle and install the five lug bolts to secure the wheel. Torque to 95-105 Ft. lbs. (130 - 140 N m)

To Remove and Reinstall a Brake and Spindle Assembly

1. Jack up the machine at a designated jacking point.
2. Install safety stands or blocks to support the machine while you work on it.
3. Remove the Wheel from the Brake and Spindle Assembly.
4. Remove the clevis and yoke holding the Rod End to the Brake Lever.
5. Remove the four 1/2"-20 hex screws and remove the Brake and Spindle Assembly from the machine.
6. Reinstall the Brake and Spindle Assembly by following the above steps in reverse order.

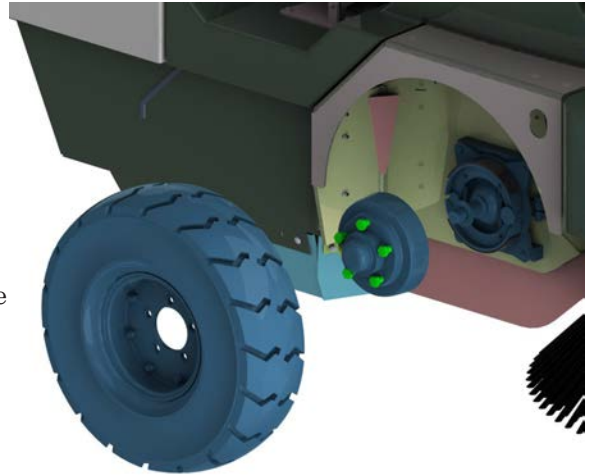

Wheel System, Traction

Functional Description

Overview

The traction wheel system includes the piston (drive) pump, hydraulic traction drive motor, foot pedal, and the forward/reverse controls that control the direction and speed of the drive motor.

The traction drive motor is driven by the variable-displacement piston pump which allows speed and directional control. The piston pump and drive motor hydraulic system is a closed system, but allows for oil leakage through the drive pump for lubrication and cooling purposes. This leaked oil returns to the reservoir through the case drain, and requires make-up oil that is supplied to the drive pump through the charge circuit from the oil cooler and filter.

Piston (drive) Pump and Drive Motor

The **Piston Pump** is driven by the engine and powers the hydraulic **Drive Motor**.

Hydraulic lines **A** and **B** connect the **Piston Pump** to the **Drive Motor**.

The **Case Drain Port** is connected to the reservoir. The **Charge Pressure Inlet** is connected to the filter.

When the internal tow valve in the **Piston Pump** is actuated, it bypasses the hydraulic circuit from the **Piston Pump** to the **Drive Motor** to allow the rear drive wheel to rotate freely when towing or pushing the machine. (Refer to the **General Information** section for instructions on how to set the tow valve when towing or pushing the machine.)

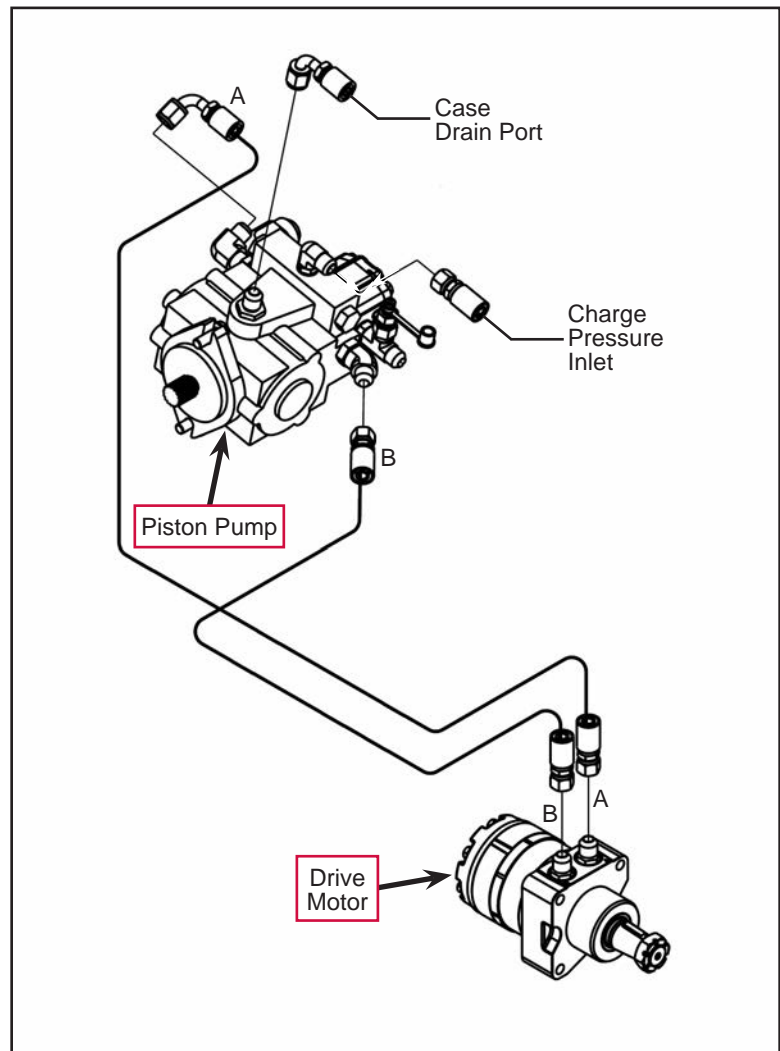

Foot Pedal Assembly

The **Foot Pedal** pivots in the **Foot Throttle Plate** to move the **Lever Weldment Push/Pull Control Cable** forward and backward. The **Lever Weldment Push/Pull Control Cable** actuates the forward/reverse controls connected to the piston (drive) pump.

Forward/Reverse Controls

The forward/reverse controls connect the **Foot Pedal** to the drive pump control shaft. Pressing the **Foot Pedal** changes the angle of the swash plate inside of the drive pump.

- The direction in which the swash plate is moved determines which port on the drive motor receives the hydraulic oil from the piston pump. This determines the machine direction.
- The distance to which the swash plate is moved determines the volume of hydraulic oil the piston pump sends to the drive motor. This determines the machine speed.

The **Foot Pedal** actuates the **Lever Weldment Push/Pull Control Cable** which actuates the **Hydroback**. The **Rod End** on the **Hydroback** pivots the **Lever** and attached **Lever Weldment** connected to the piston pump control shaft to control the oil direction and flow volume from the pump to the drive motor.

The **Hydroback** returns the **Lever Weldment**, piston pump control shaft and **Foot Pedal** to the neutral position when the **Foot Pedal** is released.

The **Cam Push/Pull Control Cable** is connected to the hopper and the **Nylon Cam**. When the hopper is raised, the **Cam Push/Pull Control Cable** rotates the **Nylon Cam** to limit the rotation of the **Lever Weldment**. This restricts the machine travel speed when the hopper is raised.

The **Rotary Sensor** (referred to as the **Drive Pedal Sensor**, 5K Ohm in the electrical ladder diagram) is coupled to the **Lever Weldment**. The **Rotary Sensor** must be in its “deadband” range before the engine can be started. (Refer to the **Hydrostatic Neutral Position and Dead-band** section for instructions on how to set the **Rotary Sensor**.)

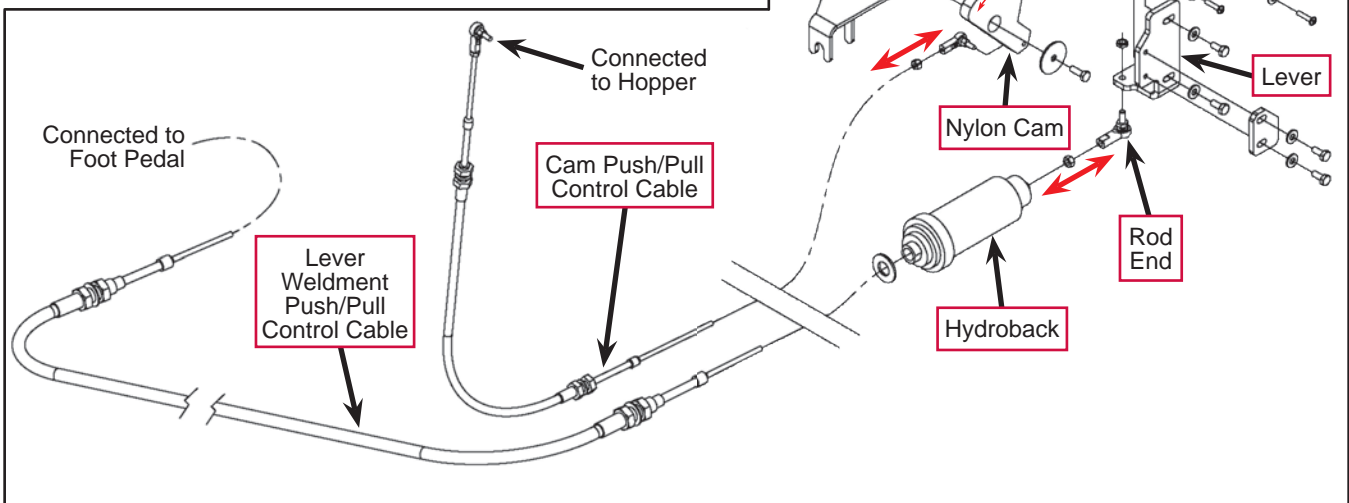
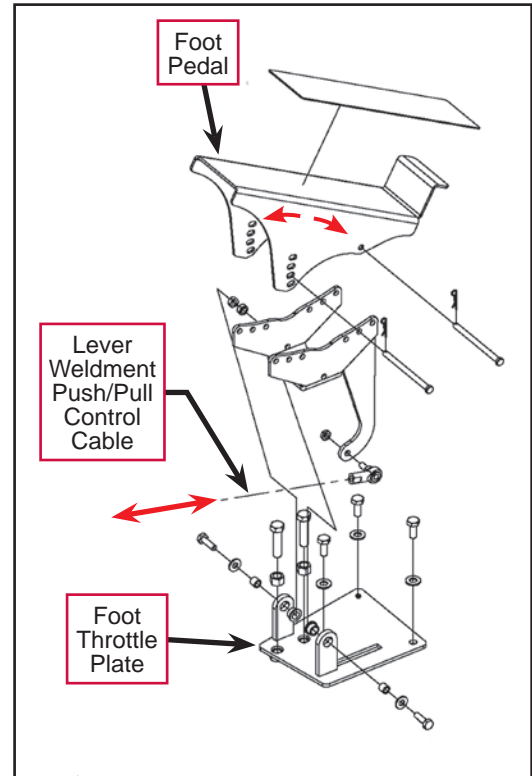

Rear Wheel Assembly

The **Rear Wheel Assembly** is bolted to the **Drive Wheel Hub**. The **Rear Wheel Assembly** and attached **Drive Wheel Hub** fit onto the keyed, tapered shaft on the **Drive Motor**. A **Slotted Nut** and **Cotter Pin** hold the **Drive Wheel Hub** and attached **Rear Wheel Assembly** onto the **Drive Motor** shaft. The **Drive Motor** is bolted to the **Drive Yoke Weldment**.

The **Steering Cylinder** extends and retracts to rotate the **Drive Yoke Weldment** and attached **Drive Motor/Drive Wheel Hub/Rear Wheel Assembly** about the **Drive Yoke Pivot Pin** to steer the machine.

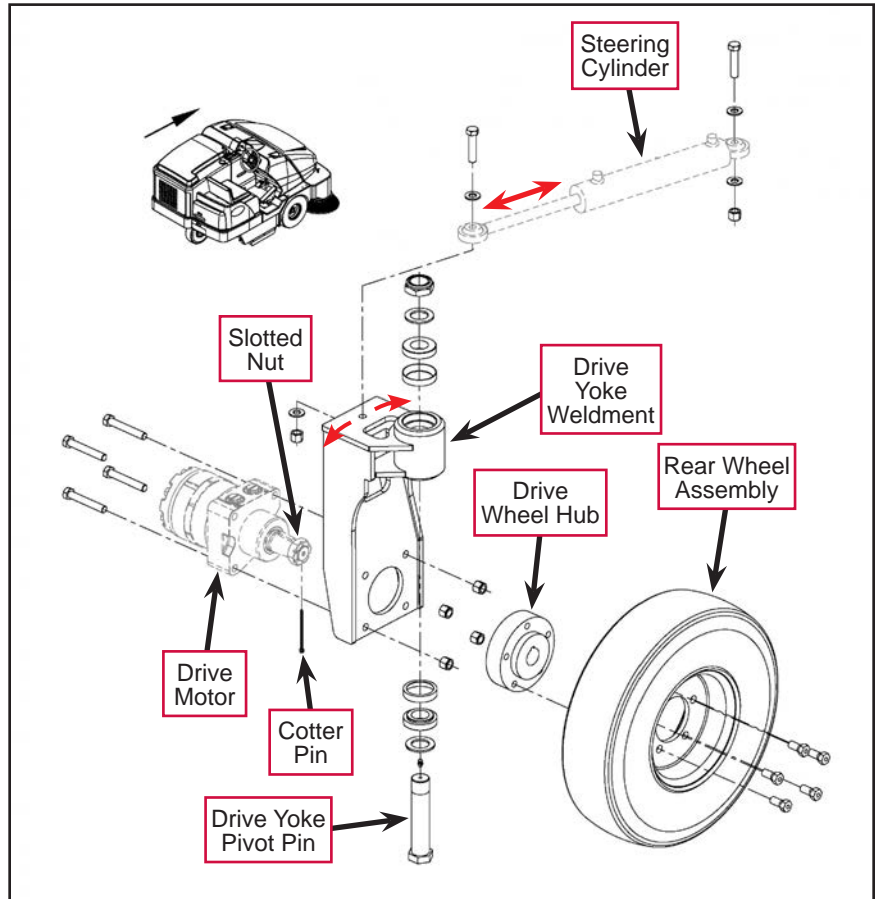

Electrical Schematic and Circuit Description

The only electrical component associated with the traction wheel system is the **5K Ohm Drive Pedal Sensor** (referred to as the **Rotary Sensor** in the Parts List). The **5K Ohm Drive Pedal Sensor** is a rotary potentiometer that is coupled to the **Lever Weldment**. (Refer to the lower drawing on the preceding page.) The resistance through the **5K Ohm Drive Pedal Sensor** varies according to the rotary position of the **Lever Weldment**.

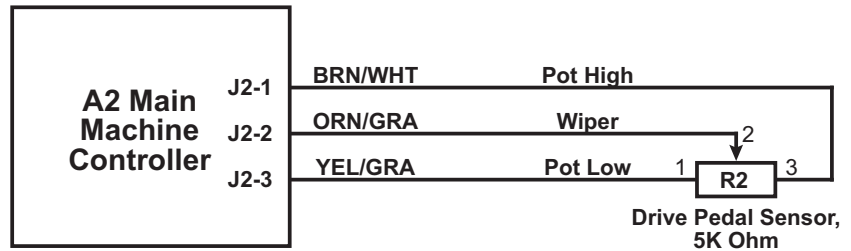

The **A2 Main Machine Controller** senses the resistance through the **5K Ohm Drive Pedal Sensor**. This resistance must be within a preset “deadband” range that indicates that the piston pump is in the neutral position before the engine starter is allowed to operate. This is a safety feature to ensure that the piston pump is in its neutral position when the engine is started.

Hydraulic Diagrams

Drive Motor in Neutral

When the foot pedal is in the neutral position with the engine running, the **Piston Pump** will not send any oil to the **Drive Motor**.

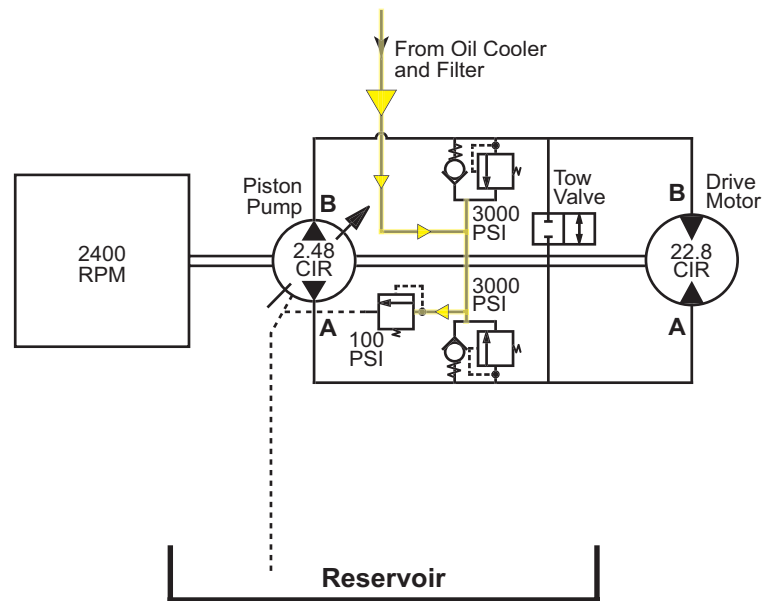

Tow Valve in Bypass Position

If the **Drive Motor** is mechanically rotated by towing or pushing the machine, it acts as a pump. Since there is no place for the hydraulic oil to flow, the wheel may not turn at all, and may skid across the floor if the machine is towed or pushed with great enough force. The machine is equipped with a **Tow Valve** to eliminate this problem when towing or pushing the machine.

When the **Tow Valve** is rotated to the bypass (open) position, the oil is free to flow to and from the **Drive Motor** through the **Tow Valve** when the rear wheel is rotated, bypassing the **Piston Pump**. (Refer to the [General Information/Towing or Pushing the Machine](#) subsection in this manual.)

Note that while only one drive wheel direction is shown in the adjacent drawing, the **Tow Valve** functions the same when the drive wheel is moved in either forward or reverse.

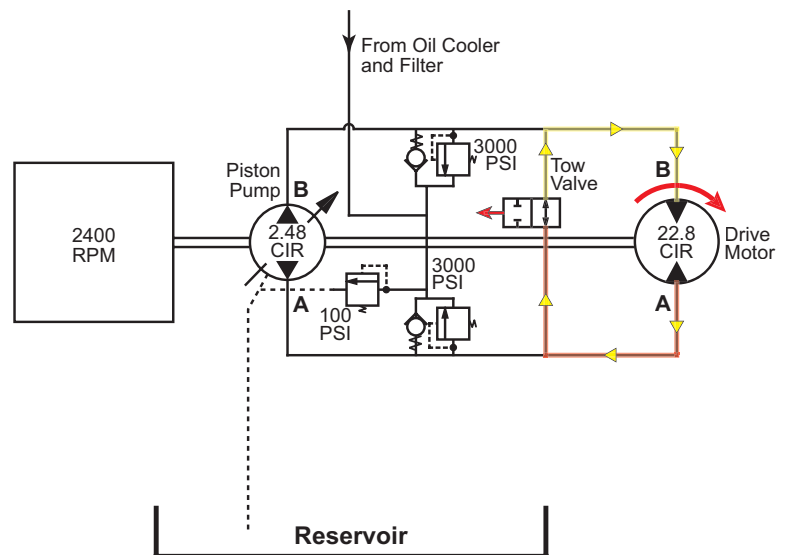

Drive Motor in Forward or Reverse

When the engine is running and the foot pedal is moved to either the forward or reverse position, the **Piston Pump** sends oil to the **Drive Motor** to drive the machine in the corresponding direction. The swash plate in the **Piston Pump** regulates the direction and volume of oil the **Piston Pump** sends to the **Drive Motor** to control the machine direction and speed.

The direction in which the foot pedal moves the swash plate in the **Piston Pump** controls the machine direction. The distance to which the foot pedal moves the swash plate in the **Piston Pump** controls the machine speed.

The return oil from the from the **Oil Cooler** and **Filter** passes through the appropriate **Check Valve** to provide make-up oil to the return (slack) side of the **Piston Pump**.

When the return oil pressure from the **Oil Cooler** and **Filter** exceeds 100 psi, the **100 PSI** piloted relief valve opens to allow the return oil to flow to the **Reservoir**.

The case drain from the **Piston Pump** goes to the **Reservoir**.

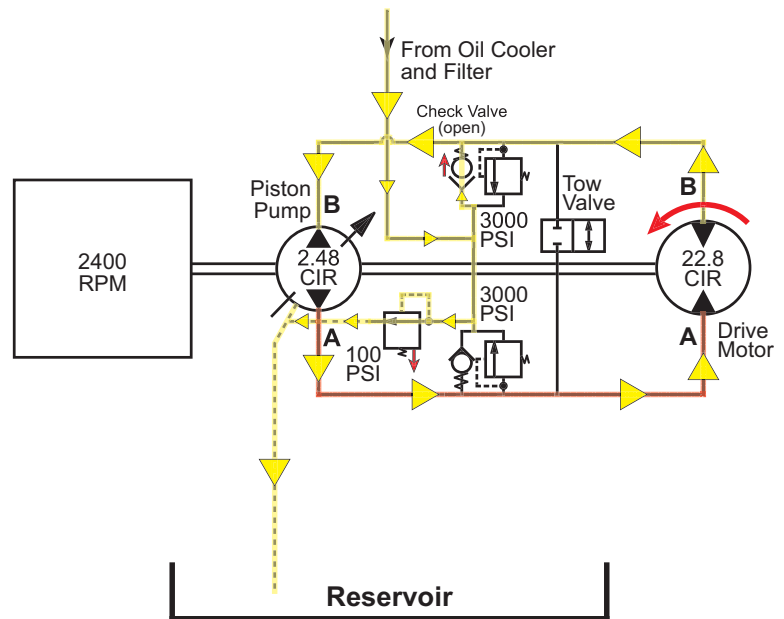
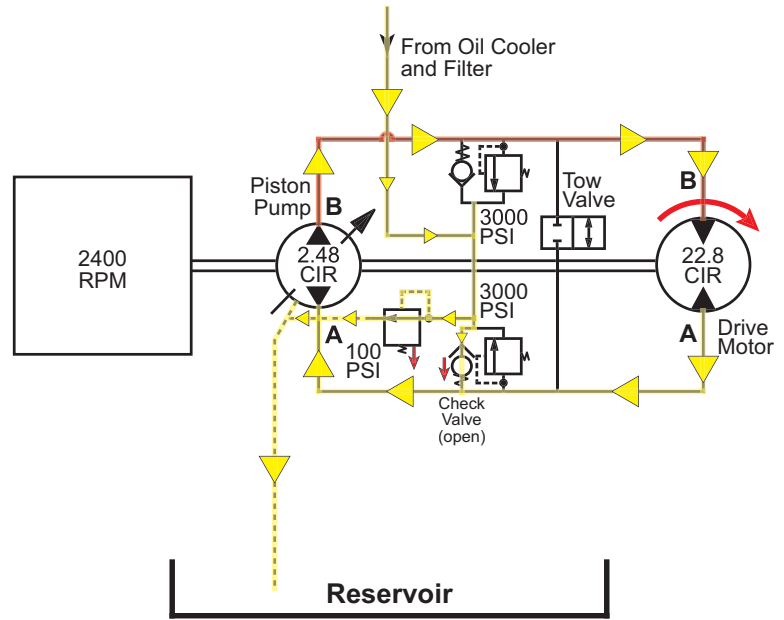

Drive Motor Stalling Out

If the **Drive Motor** is unable to run in forward or reverse for any reason (rear wheel stalled, etc.), the corresponding internal **3000 PSI** relief valve in the **Piston Pump** will open to bypass the **Drive Motor** to prevent damage to the hydraulic components.

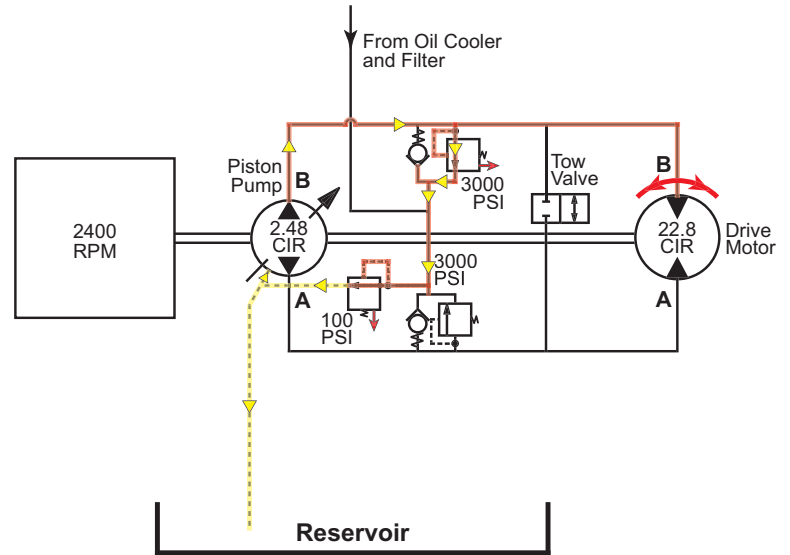

Component Locations

The following components are included in this section:

- Piston (drive) Pump and Tow Valve
- Drive Motor and Rear Wheel Assembly
- Foot Pedal Assembly
- Forward/Reverse Controls

Piston (drive) Pump and Tow Valve

The **Piston Pump** (blue) is attached to the front end of the engine. The **Tow Valve** is mounted onto the **Piston Pump**.

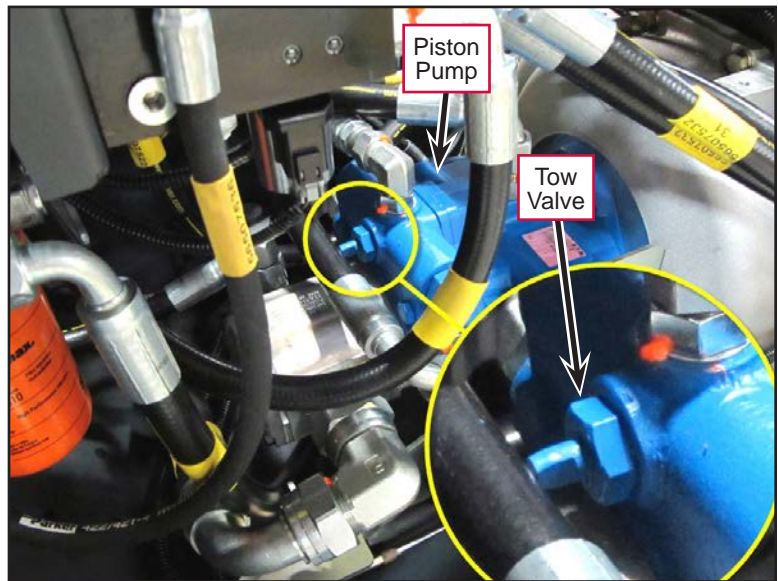

Drive Motor and Rear Wheel Assembly

The **Drive Motor** and **Rear Wheel Assembly** are mounted to the **Drive Yoke Weldment**.

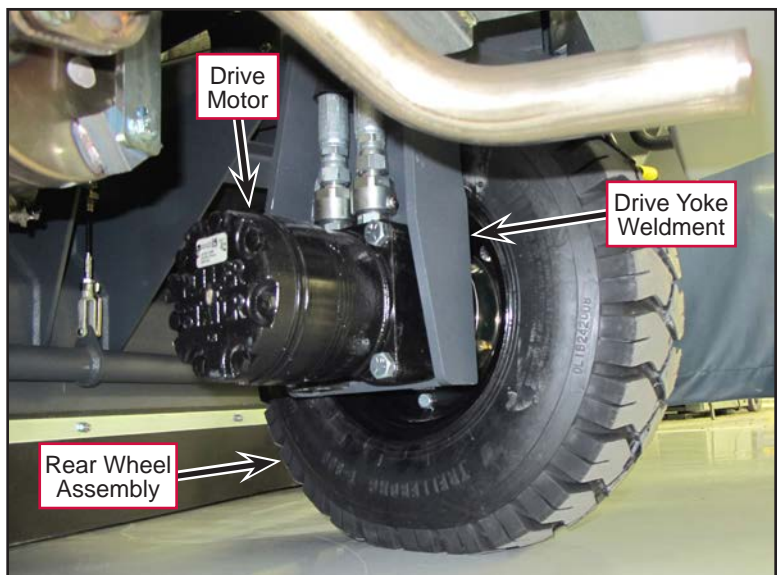

Foot Pedal Assembly

The **Foot Pedal Assembly** actuates the forward/reverse controls to control machine direction and speed.



Forward/Reverse Controls

The lever weldment push/pull control cable, **Lever Weldment**, **Lever**, **Nylon Cam** and **Hydroback** are mounted on the left side of the machine underneath the center cover assembly/DustGuard™ tank.

The **Rotary Sensor** is coupled to the **Lever Weldment** and is mounted to the **RTN Bracket**.

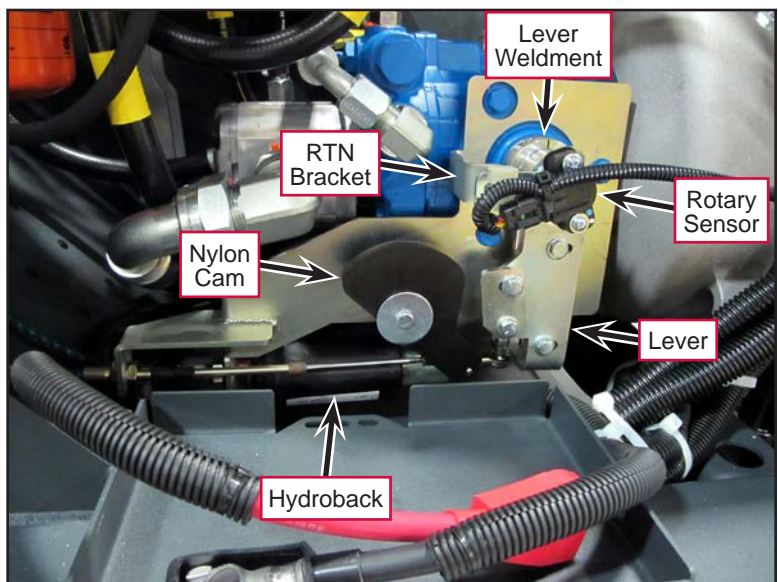

Adjustments

To Set the Drive Pump Neutral Position

1. Jack up the rear of the machine to get the drive wheel up off the ground.
2. Install safety blocks or stands to support the rear of the machine.
3. Remove the center cover assembly/DustGuard™ tank to access the forward/reverse controls.



Note: If your machine is equipped with a DustGuard™ system, you'll need to disconnect the hose coupling on the DustGuard™ tank before you remove the DustGuard™ tank from the machine.

4. Start the engine and observe the wheel rotation with the engine idling. If the wheel is rotating either forward or reverse with the foot pedal in the neutral position, adjust the position of the **Lever Weldment** as follows:
5. Loosen the two **1/4"-20 x .62" Screws** holding the **Lever** to the **Lever Weldment**.
6. Rotate the **Lever Weldment** as necessary until the wheel stops turning.
7. Tighten the two **1/4"-20 x .62" Screws**.
8. Shut the engine off.
9. Reset the foot pedal deadband setting. (Refer to the **Control System/Main Machine Controller Programming/Hydrostatic Neutral Position and Dead-band** section.)
10. Reinstall the center cover assembly/DustGuard™ tank.
11. Reconnect the DustGuard™ tank hose coupling (if applicable).

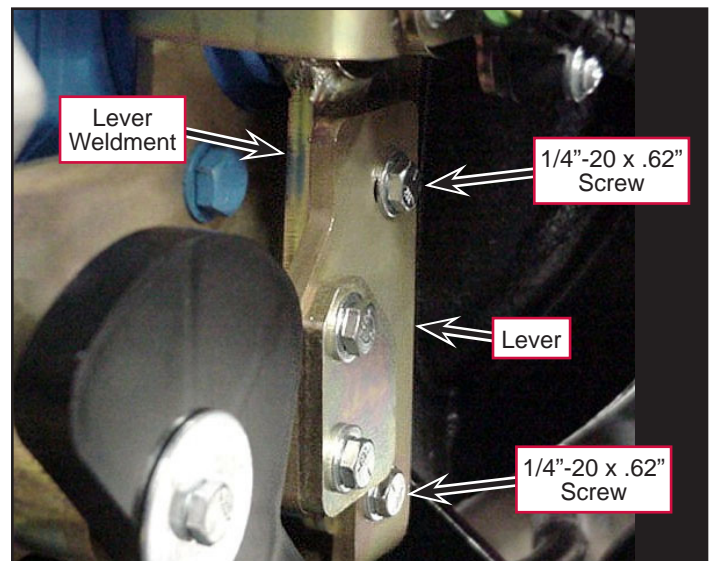
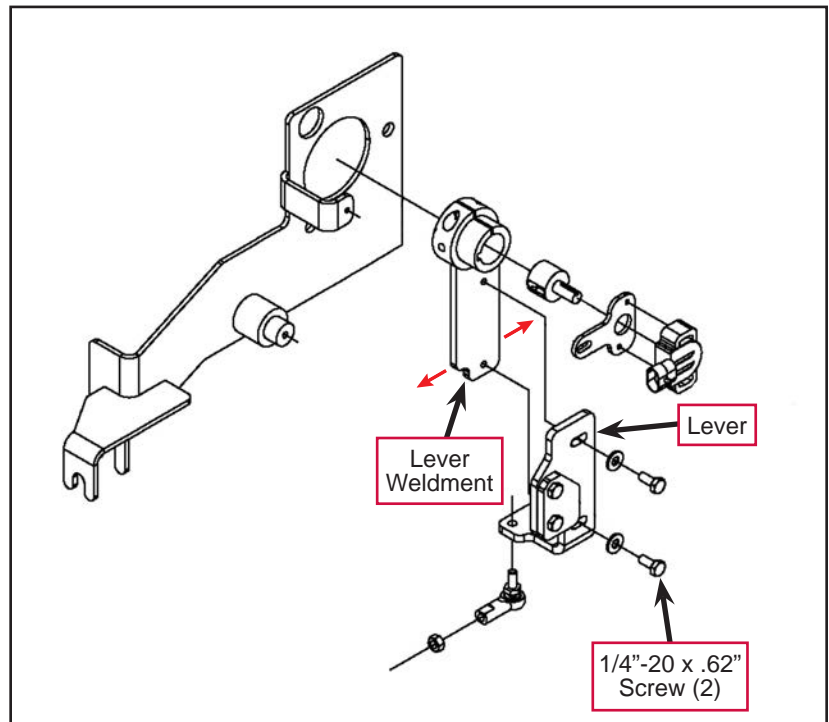

Troubleshooting

Problem	Cause	Correction
The machine won't start.	The foot pedal deadband position is not set correctly.	Reset the foot pedal deadband position.
The machine "creeps" forward or backward when the foot pedal is in the neutral position.	The forward/reverse controls are out of adjustment.	Adjust the forward/reverse controls and/or linkage so the machine is stationary when the foot pedal is in the neutral position.
	The cable or forward/reverse controls are damaged or dirty.	Clean or replace the cable or forward/reverse controls as necessary.

Specifications

Component	Specifications
Tire (rear) Drive/Steer	Size – 5 in. x 8 in.
	Rear Wheel Lug Nut Torque – 100 ft.-lb. [135 Nm]
	Tire Pressure – 90 psi
Rear Drive Wheel Motor	Displacement – 22.8 CIR
	Shaft Rotation – Bidirectional
	Shaft – 1½ in., tapered w/key
Piston Pump	Type – manually-variable displacement, axial piston pump, tow valve included
	Displacement – 2.48 CIR max.
	Speed – 3600 RPM max.
	Shaft Rotation – Clockwise (as viewed from shaft end)
	Continuous pressure – 3000 psi [206.8 bar] max.
	Maximum pressure – 5000 psi [344.7 bar] max.
	Main Loop Relief Valve – set at 3000 psi [206.8 bar]