



Electronic Service Manuals

This electronic document is provided as a service to our customers. We do not create the contents of the information contained in this document. Should you have detailed questions pertaining to the information contained in this document, you may contact Michco, or the manufacturer which provided the original information in this electronic deliverable. Michco's only part in this electronic deliverable was the electronic assembly process. By providing this manual on line we are not guaranteeing parts availability.

You may contact Michco through the following methods:

Phone (517) 484-9312 or (800) 331-3339

2011 N. High St. -- Lansing, Michigan -- 48906

Fax: (517) 484-9836

Email: CustServe@Michco.com

Web site: www.Michco.Com

Parts Web site: www.FloorMachineParts.Com

Order Parts on Line at:

www.FloorMachineParts.Com

Directly to Parts & Service:

By Email: **Shop@Michco.com**

By Fax: (517) 702-2041

By Voice: Use numbers above.

Serving the Cleaning Industry Since 1922

Notice: All copyrighted material remains property of original owners, all trademarks are property of respective owners. Manuals are subject to Manufacturer's reproduction limitations. Originals or reproductions were provided by manufacturers through a request. We make no warranty as to the correctness of information provided in this document and you assume all risk. By placing these manuals on line we are not declaring our corporation to be an manufacturer authorized dealer or provider, please check our web site for authorized manufacturers we represent.

Proterra™

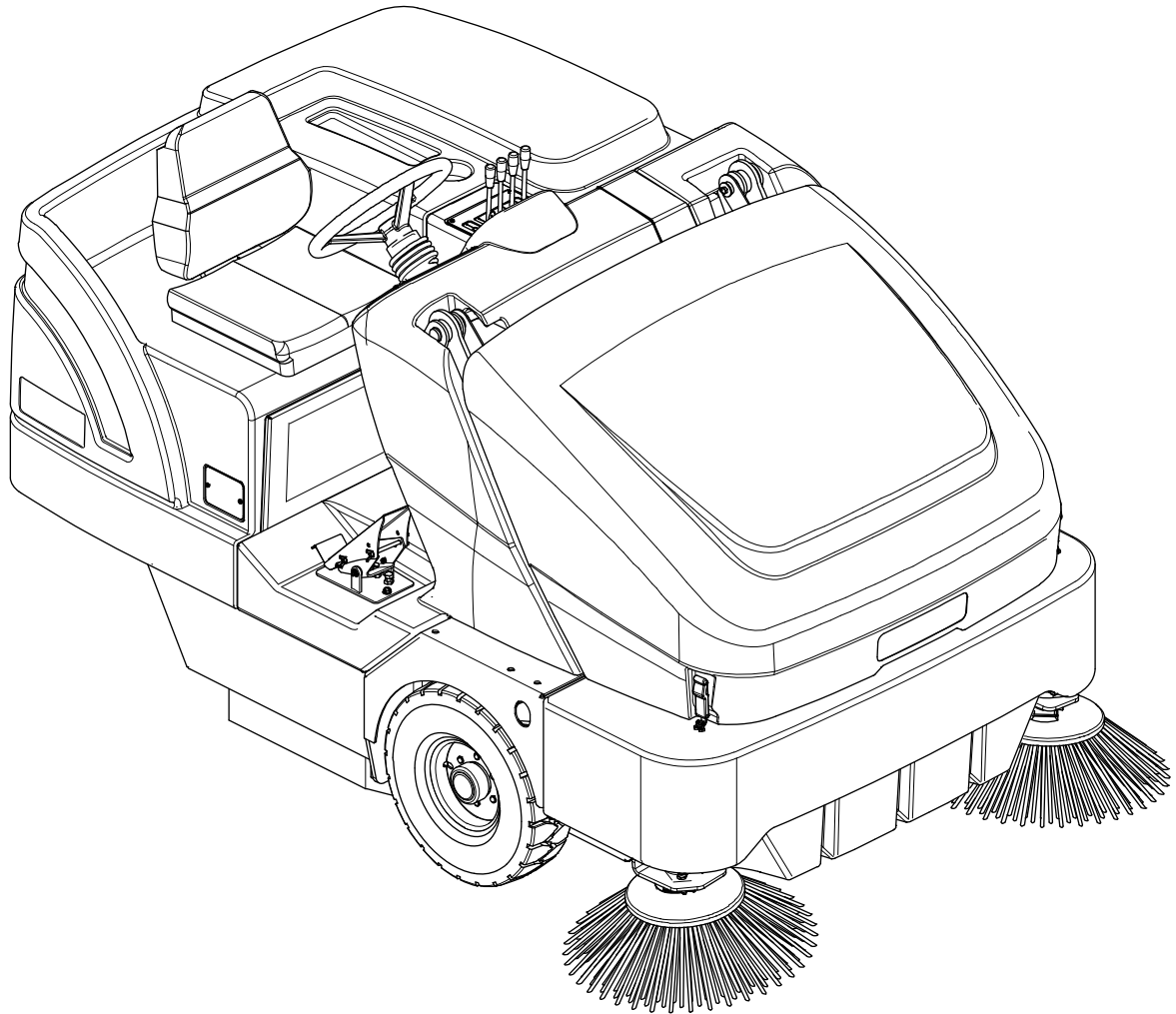

PARTS LIST

Advance models: 13300107 (Battery)
13300173 (Battery)

TABLE OF CONTENTS

ENG	PAGE
GENERAL VIEW	2 - 3
CHASSIS ASSEMBLY	4 - 7
CHASSIS COMPONENTS	8 - 9
HOPPER SYSTEM	10 - 13
VAC FAN AND PANEL FILTER ASSY	14 - 15
RT SIDE BROOM ASSY	16 - 17
LT SIDE BROOM ASSY	18 - 19
MAIN BROOM SYSTEM	20 - 21
ASSY CONTROL	22 - 23
PEDALS SYSTEM	24 - 25
ASSY SPEED LIMITING	26 - 27
ELECTRIC BOX ASSY	28 - 29
ASSY CONTROL PANEL AND REALYS	30 - 31
ASSY REAR COVER	32 - 33
ELECTRIC MOTOR ASSY	34 - 35
ASSY HYDRAULIC PLANT	36 - 41
HYDRAULIC PLANT - DRIVE MOTOR SCHEME	42 - 43
HYDRAULIC PLANT - STEERING SCHEME	44 - 45
HYDRAULIC PLANT - FLAP AND HOPPER SCHEME	46 - 47
HYDRAULIC PLANT - SIDE BROOM SCHEME	48 - 49
ACCESSORIES	50 - 59
WIRING DIAGRAM	60 - 63
HYDRAULIC DIAGRAM	64 - 65
RECOMMENDED SPARE PARTS	66
OPTIONALS	67

WHEN ORDERING PARTS

- * Use the part numbers from the "Ref. No." columns in this parts list.
- * Specify the model and serial number of the machine.
- * Use the space below to record the model and serial number for future reference.

Model

Serial No.

* = Optional

= Modified item No. or New item No.

[] = Not shown

GENERAL VIEW

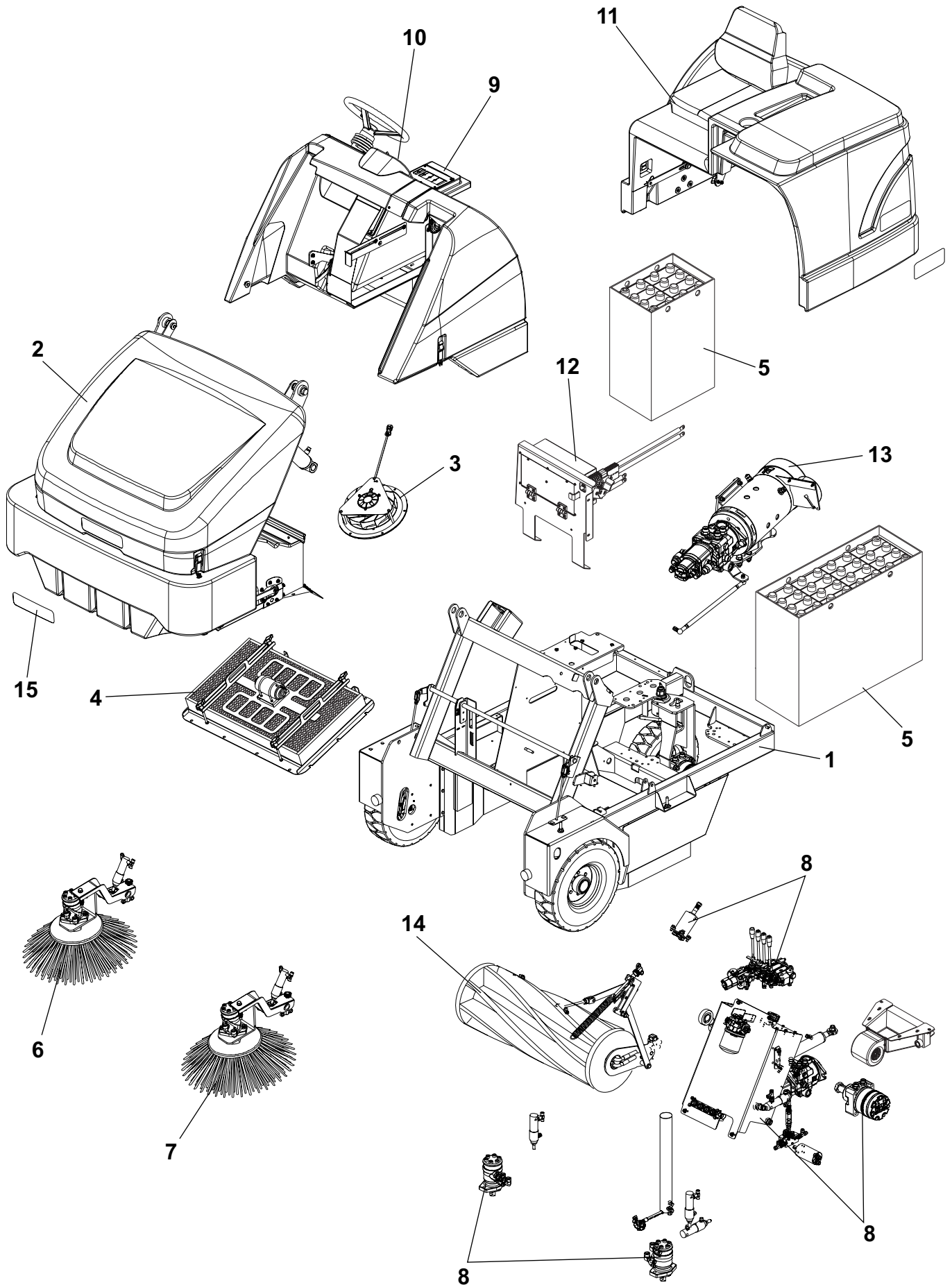

GENERAL VIEW

ITEM	REF. NO.	QTY	DESCRIPTION
1		1	CHASSIS ASSEMBLY
2		1	HOPPER SYSTEM
3		1	VAC FAN ASSY
4		1	PANEL ASSY
5*	80562010	1	BATTERY TRACTION 48 V 375 A (BAT)
6		1	RIGHT SIDE BROOM ASSY
7		1	LEFT SIDE BROOM ASSY (OPTIONAL)
8		1	HYDRAULIC PLANT ASSY
9		1	CONTROL ASSY
10		1	CONTROL PANEL AND RELAYS ASSY
11		1	REAR COVER ASSY
12		1	ELECTRIC BOX ASSY
13		1	ELECTRIC MOTOR ASSY
14		1	MAIN BROOM SYSTEM
15	33020133	1	LABELS KIT PROTERRA™
[16]*	80562030	1	BATTERY CHARGER 48V 50Ah

CHASSIS ASSEMBLY

ITEM	REF. NO.	QTY	DESCRIPTION
1		4	WASHER 8X24 UNI6592
2		4	WASHER 10X30 UNI6592
3	33003125	1	RING NILOS AV
4	33003129	2	VIBRATION -DAMPING
5	33003201	4	SUPPORT SBPP 204
6		9	WASHER 8X24 UNI6593
7		3	SCREW M8X16 UNI5739
8		1	SCREW M8X45 UNI5739
9		8	SCREW M8X20 UNI5931
10		2	SCREW M6X16 UNI5933
11		8	SCREW M10X40 UNI5933
12		15	SCREW M8X20 UNI5739
13		2	NUT HEX M10 UNI5588
14		1	NUT HEX M10 UNI5589
15		9	NUT SELF L. M8 UNI7474
16		2	NUT SELF L. M10 UNI7474
17		1	NUT SELF L. M24X2 UNI7474
18		2	WASHER M10 UNI8842A
19		5	STUD BOLT M 16X1.5
20		1	LUBRICATOR M6
21	33009812	1	PLUG
22		2	SPINDLE
23	33016904	2	CAP
24	33016909	1	RING NILOS AV
25	33016910	1	WASHER UPPER
26	33016911	1	WASHER LOWER
27	33016912	1	PIN DRIVE YOKE PIVOT
28		2	WASHER 12X40X4
29		2	SCREW THREAD ROLLING M6X12
30		10	SCREW THREAD ROLLING M8X12
31	33017292	1	CHASSIS WELDED BATTERY
32	33017057	1	DOOR LEFT WELDED
33		1	PLATE REAR SEAL
34		2	PLATE SIDE SEAL
35	33017113	1	BAR JOINT BRAKE
36	33017114	1	PLATE BAR JOINT BRAKE
37	33017168	1	FLAP BROOM CHAMBER HOSES
38		1	HOPPER SAFETY STOP
39	33017171	1	FLAP SIDE
40	33017172	1	FLAP SIDE
41	33017173	2	FOAM HOPPER SIDE
42	33017174	1	FLAP REAR BROOM
43		2	BUSH
44		6	RIVET PLASTIC
45		4	CAP VINYL
46	33017199	1	SPRING
47	33017220	1	LINKAGE WELDED THROTTLE
48	33017262	1	STATIC STRAP
49	33017266	2	FLAP WHEEL WELL TOP
50		2	SCREW M10X55 UNI5739
51		2	SCREW M12X20 UNI5739
52	33020206	2	BRAKE LINING AND SPRING ASSY
53	33018539	1	COLLAR DOUBLE D.18
54	33020204	2	DRUM BRAKE ASSY
54	33020205	2	DRUM BRAKE KIT
55		3	PLUG BLACK
56		1	WASHER
57		1	SCREW M10X45 UNI5933
58		2	WASHER M24 UNI6592
59	33022785	2	LEVER BRAKE
60	33018790	1	SUPPORT FRONT WHEEL KIT (ITEM 22-11)

CHASSIS ASSEMBLY

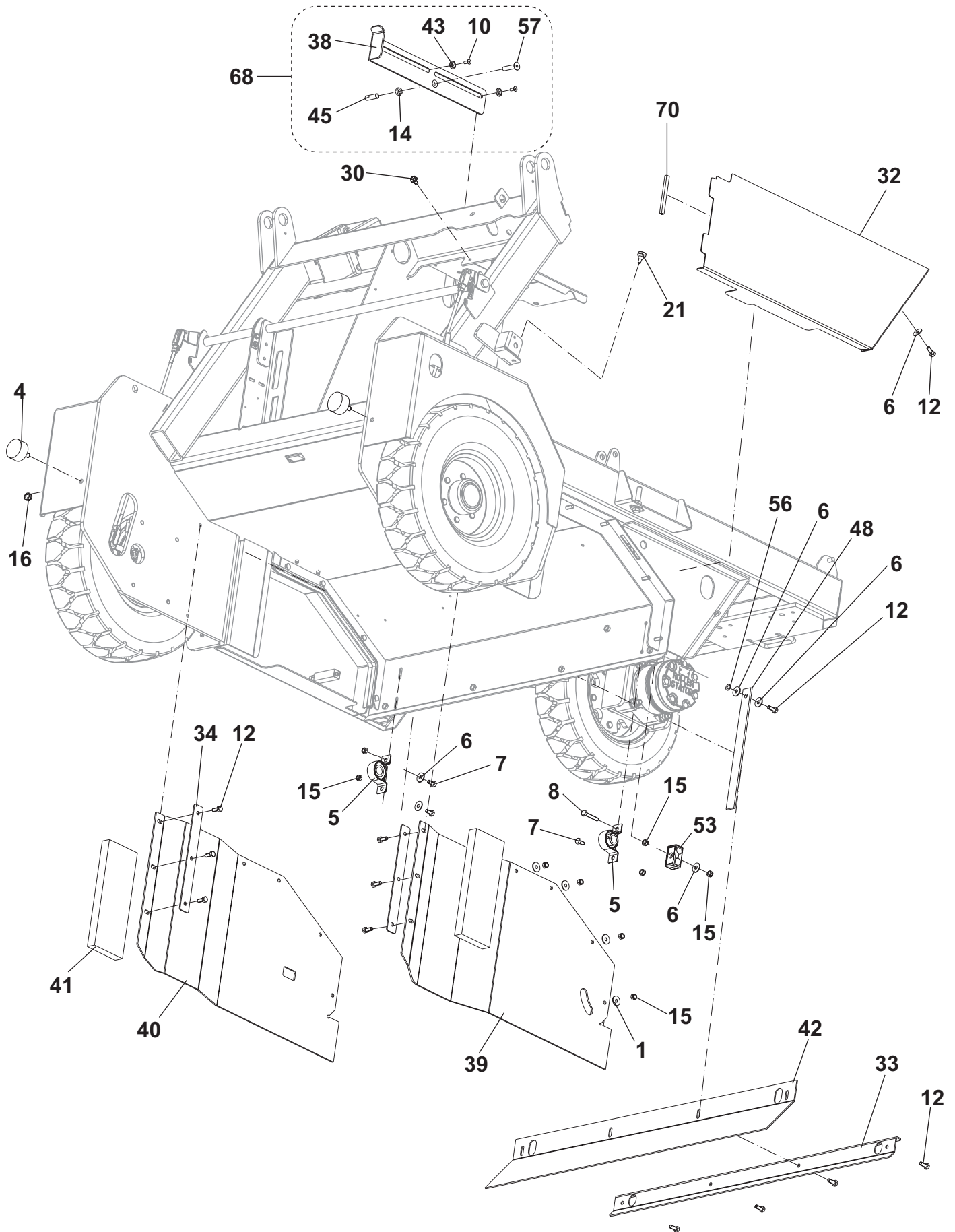

CHASSIS ASSEMBLY

ITEM	REF. NO.	QTY	DESCRIPTION
61	33020409	1	CENTRING HARDWARE KIT (ITEM 5 ITEM 0-45-18-13-2)
[62]	33020410	1	BRAKE ROD HARDWARE KIT (ITEM 29-44)
63	33020411	1	FRONT WHEELS SUPPORT HARDWARE KIT (ITEM 9-28-51)
64	33020412	1	REAR WHEEL PIN HARDWARE KIT (ITEM 58-20-17)
[65]	33020332	1	CHASSIS HARDWARE KIT (ITEM 3-13-16 SEE PAGE 9 / 51-50-58-55-45-44-29-28-20-19-18-17-13-12-11-9-6-2)
[66]	33018791	1	FIXING GASKETS KIT (ITEM 12-33-34-1-15)
[67]	33020333	1	FLAP HARDWARE KIT (ITEM 16-6-12-15-1)
68	33019212	1	HOPPER STOP KIT (ITEM 57-45-43-38-14-10)
[69]	33018866	1	SUPPORT BEARING KIT (ITEM 5-15-8-7-6)
70	33021180	1	SEAL EDGE PROTECTOR KIT

CHASSIS COMPONENTS

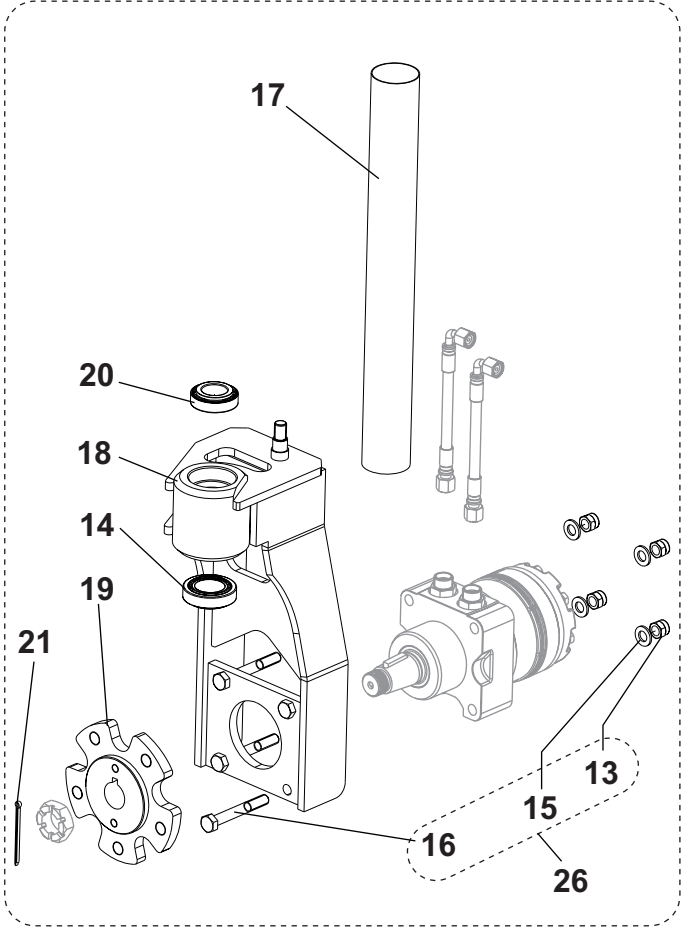
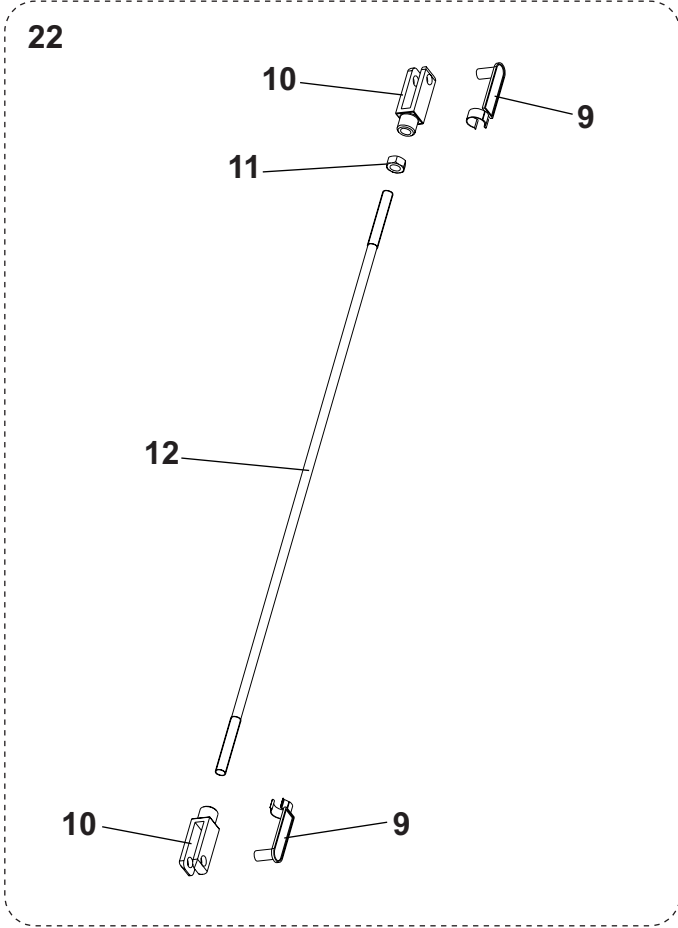
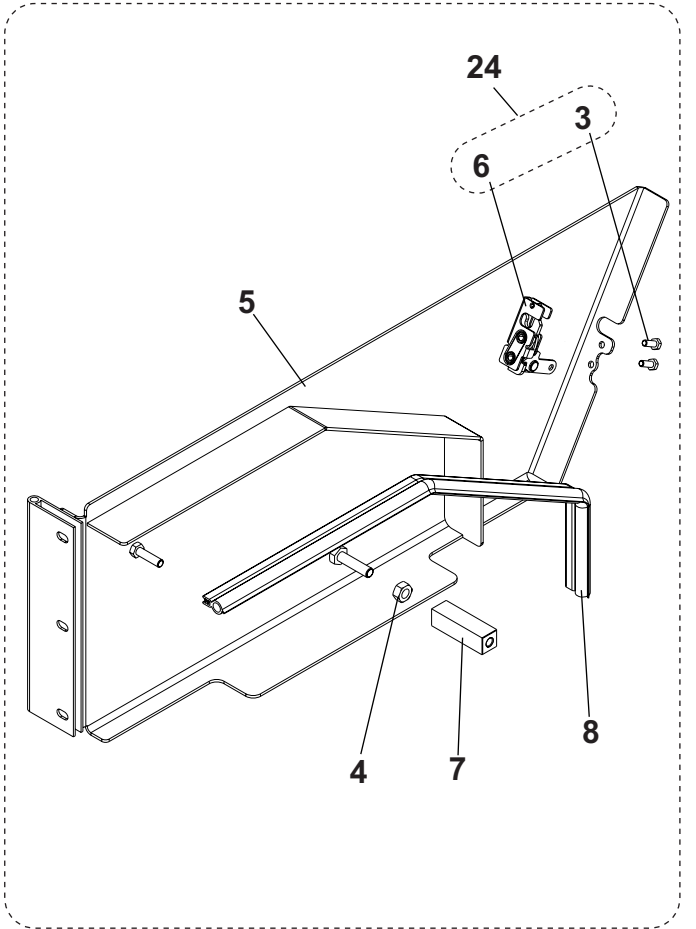
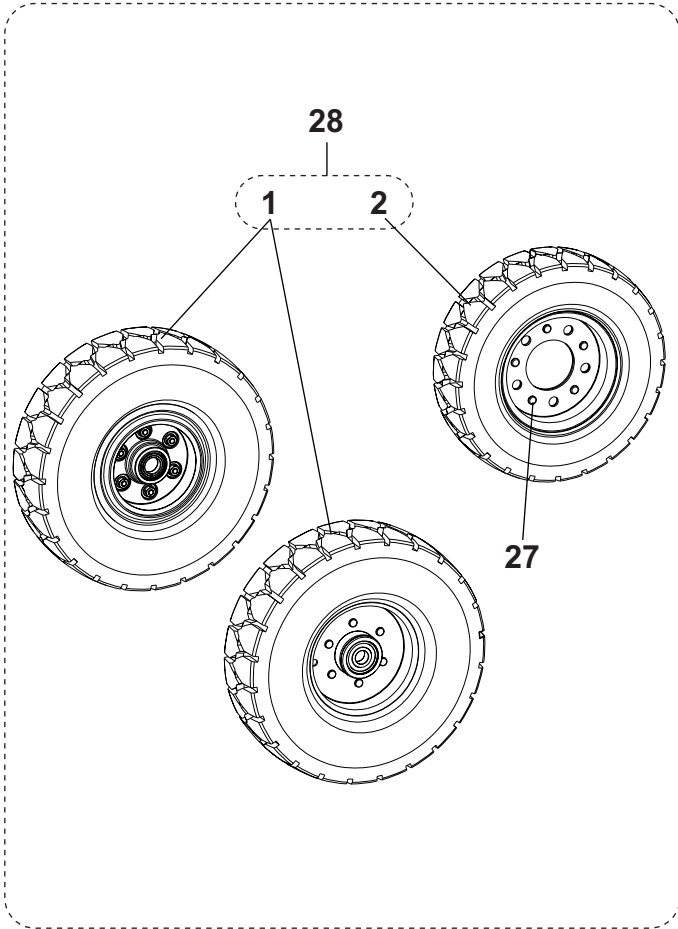

CHASSIS COMPONENTS

	ITEM	REF. NO.	QTY	DESCRIPTION
	1	33022519	2	WHEELS SUPERELASTIC 5.00/8 KIT
#	2	33023124	1	WHEEL SUPERELASTIC GUMASOL 4.00/8 PKD
	3		2	SCREW M6X16 UNI5739
	4		1	NUT HEX M10 UNI5588
#	5	33019101	1	HATCH RIGHT KIT (INCLUDED ITEM 12-6 PAG 5)
	6		1	LATCH SLAM
	7	33017128	1	STOP BROOM ARM
	8	33017129	1	STOP BROOM ARM
	9		4	CLIPS M8
	10		4	FORK M8
	11		2	NUT HEX M8 UNI5588
	12		2	ROD
	13		4	NUT SELF L. M12 UNI7473
	14	33003175	1	BEARING 32007
	15		4	WASHER M12 UNI6592
	16		4	SCREW M12X90 UNI5737
	17	33015544	1	SHEATH 90 D56 L 700
#	18	33018792	1	SUPPORT REAR WHEEL KIT (ITEM 13-15-16-21)
	19	33017103	1	HUB REAR WHEEL
	20	145 4691 000	1	BEARING 32006
	21		1	PIN COTTER
	22	33018794	1	CONNECTION BRAKE KIT (ITEM 9-10-11-12)
	24	33018796	1	CLOSING HATCH RIGHT SIDE KIT (ITEM 3-6)
	26	33020413	1	REAR WHEEL HARDWARE KIT (ITEM 19 PAG 5 -13-15-16)
	27	33022431	5	STUD BOLT M 10X25 COMPLETE
#	28	33023020	1	WHEEL SOLID KIT

HOPPER SYSTEM

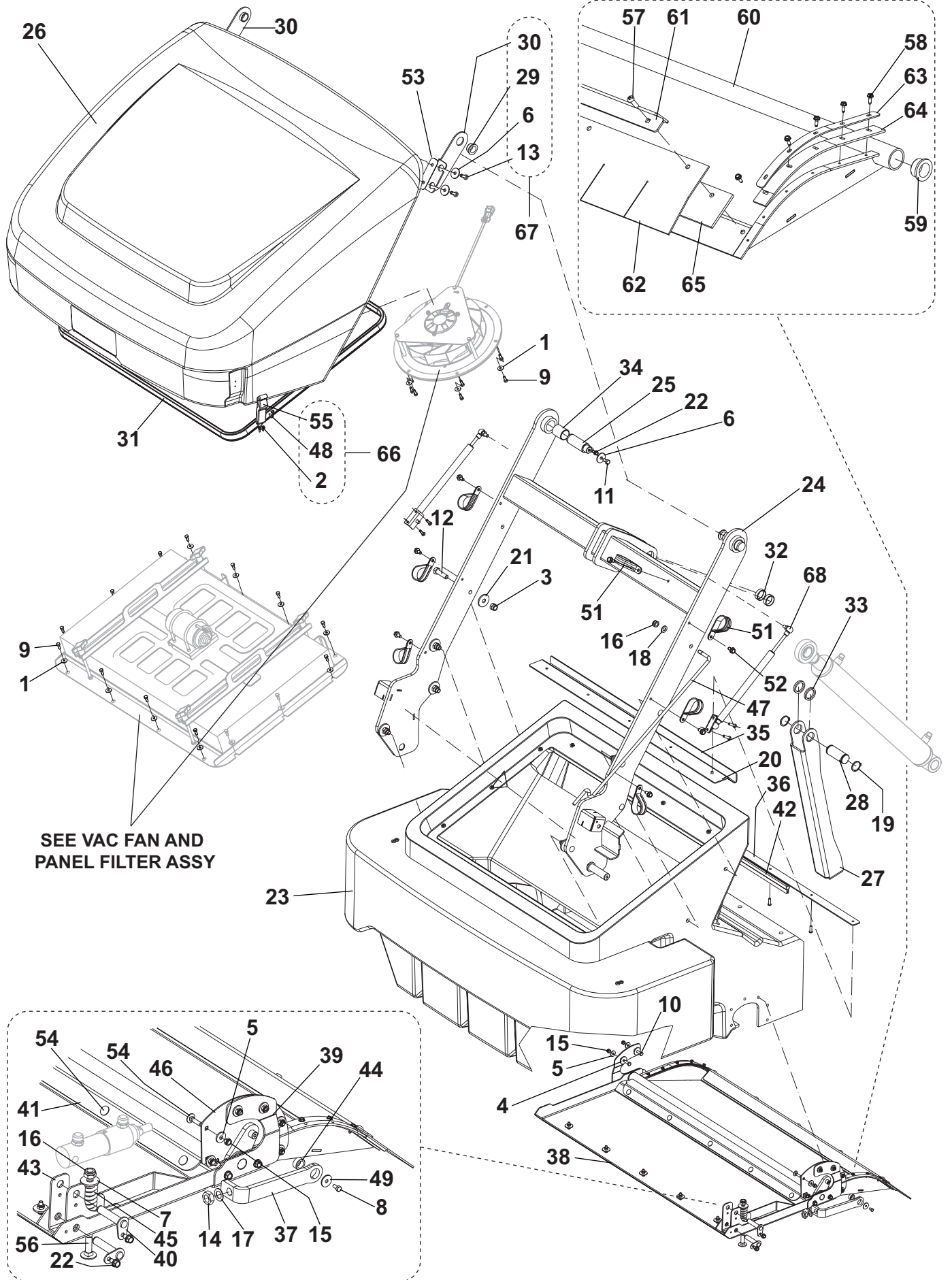

HOPPER SYSTEM

	ITEM	REF. NO.	QTY	DESCRIPTION
	1		20	WASHER 6X18 UNI6592
	2		4	SCREW M4X12 UNI7687
	3		8	NUT SELF L. M12 UNI7473
	4		7	WASHER 6X24 UNI6593
	5		13	WASHER 6X18 UNI6593
	6		6	WASHER 8X32 UNI6593
	7		1	WASHER 10X30 UNI6593
	8		1	SCREW M5X10 UNI5739
	9		20	SCREW M6X16 UNI5739
	10		2	SCREW M6X20 UNI5739
	11		2	SCREW M8X16 UNI5739
	12		8	SCREW M12X45 UNI5739
	13		4	SCREW M8X20 UNI5739
	14		1	NUT HEX M12 UNI5589
	15		18	NUT SELF L. M6 UNI7474
	16		2	NUT SELF L. M10 UNI7474
	17		1	WASHER M12 UNI8842A
	18		1	WASHER M10 UNI6592
	19		2	RING D 30 UNI7435
	20		5	SCREW M6X20 ISO7380
	21		8	WASHER 12X40X4
	22		8	SCREW THREAD ROLLING
	23	33017058	1	HOPPER
	24	33017059	1	ARM HOPPER
	25	33017060	2	PIN HOPPER PIVOT
	26	33017061	1	COVER HOPPER MOLDED
	27	33017108	1	BAR SECURITY
	28		1	PIN SECURITY BAR
	29		2	BUSH
	30		2	BRACKET HOPPER COVER
	31	33017126	1	SEAL HOPPER COVER L 2930
	32		2	BUSH
	33		2	SPACER
	34		2	BUSH
	35		1	PLATE HOPPER TOP
	36		1	STRAP DOOR PIVOT FLAP
	37	33017137	1	ARM FLAP
	38	33017138	1	PLATE HOPPER BUTTOM
	39	33017139	2	PIN HOPPER DOOR
	40	33017146	2	PIN
	41	33017229	1	PLATE HOPPER FLAP
	42	33017257	1	TRIM EDGE BULB L 900MM
	43		1	CYLINDER BRAKET
	44		1	BEARING
	45	33017287	1	SPRING
	46	33017288	1	PLATE W/BOLTS
	47		1	ROD COVER PROP
	48		4	SCREW 4.8X16 UNI6954
	49		1	WASHER FLAT XL
	51		7	CLAMP HOSE D.45
	52		7	SCREW THREAD ROLLING
	53	33020011	2	PLATE OF CONTRAST
	54		13	SCREW M6X25 UNI5731
	55		2	LATCH
	56		1	SCREW M10X60 UNI5731
	57		5	SCREW M6X20 ISO7380
	58		10	SCREW THREAD ROLLING
	59	33017116	2	BUSH
#	60	33023168	1	HATCH WASTE CONTAINER PKD
	61	33017201	1	SKIRT STRAP DOOR
	62	33017202	1	SKIRT REAR DOOR

HOPPER SYSTEM

	ITEM	REF. NO.	QTY	DESCRIPTION
	63	33017240	2	STRAP DOOR SIDE SKIRT
	64	33017241	2	SKIRT DOOR SIDE
	65		1	GASKET HOPPER DOOR
	66	33018803	1	LATCH KIT (ITEM 55-2-48)
	67	33019115	1	HINGES BONNET KIT (ITEM 13-6-29-30)
	[68]*	33021975	1	GAS SPRING KIT
		33021977	1	INSTRUCTIONS ASSEMBLY
	[69]	33017366	1	HARNESS HOPPER
	[70]	33019116	1	CLAMPS HOSES FIXING KIT (ITEM 50-51-52)
	[71]	33018799	1	PLATE CONTAINER KIT (ITEM 35-36-20)
	[72]	33018800	1	MECHANISM LIFTING KIT (ITEM 7-49-8-14-16-22-37-40-43-44-45-56-17)
#	[73]	33023167	1	SKIRT HATCH CONTAINER KIT (ITEM 15-58-59-54-61-62-63-64)
	[74]	33019117	1	GASKETS HATCH KIT (ITEM 64-62-65)
	[75]	33020414	1	HOPPER BOTTOM HARDWARE KIT (ITEM 9-17-15-12-10-5-4-29)
	[76]	33020415	1	HARDWARE SUPPORT KIT (ITEM-3-9-13-20-19-29)
	[77]	33020334	1	HOPPER HARDWARE KIT (ITEM 1-29-20-19-17-15-13-12-10-9-5-4-3)
	[78]	33018798	1	HARDWARE LIFTING CONTAINER (ITEM 6-22-25-34-33-32-19-11)
	[79]	33018801	1	FIXING ROD CONTAINER (ITEM 47-16-18)

VAC FAN AND PANEL FILTER ASSY

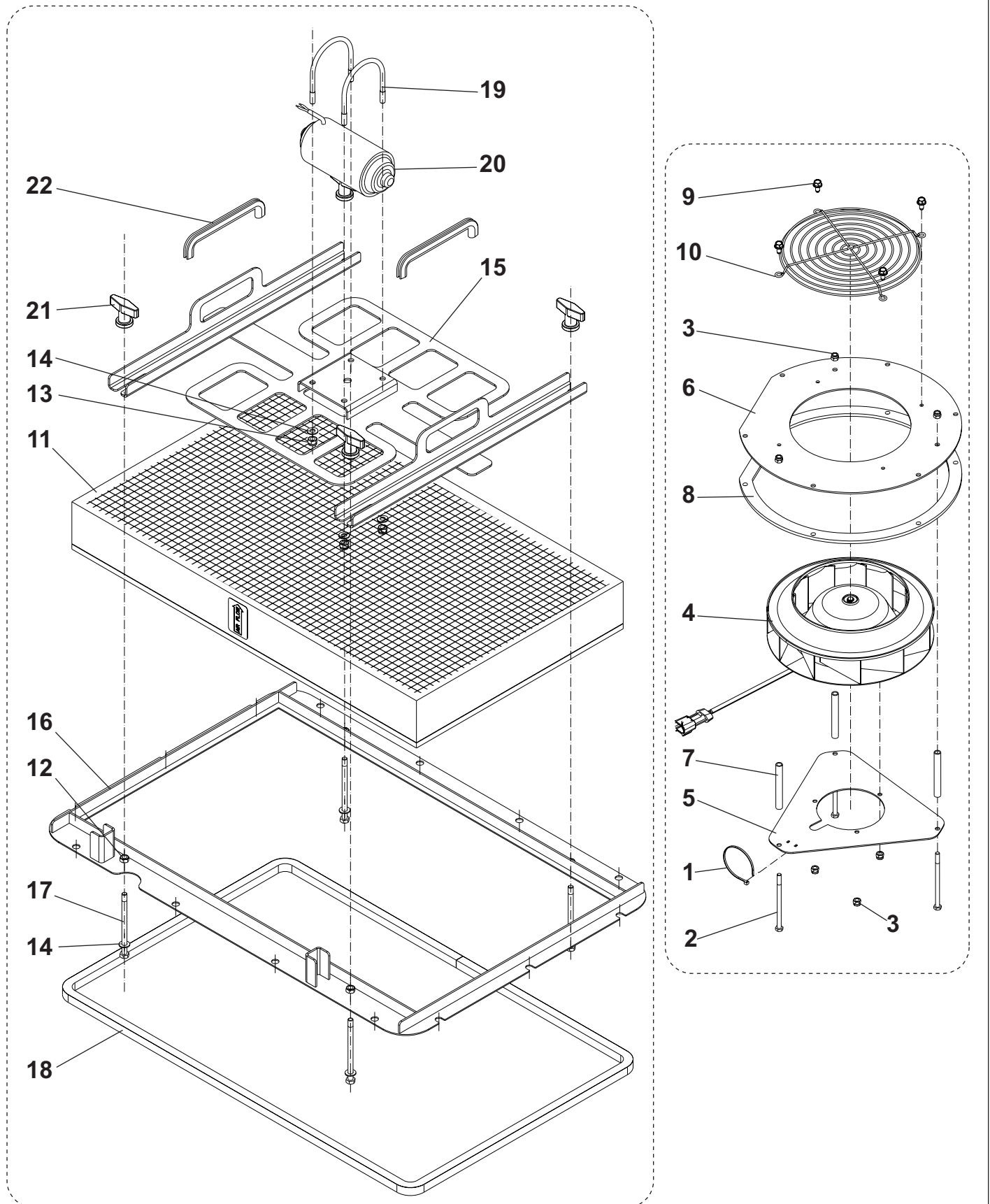

VAC FAN AND PANEL FILTER ASSY

ITEM	REF. NO.	QTY	DESCRIPTION
1		1	CABLE TIE
2		3	SCREW M6X100 UNI5737
3		6	NUT SELF L. M6 UNI7473
4	33015700	1	FAN MOTOR VACUUM 48V (M1)
5		1	SUPPORT
6		1	SUPPORT
7		3	SPACER
8	33016950	1	GASKET
9		4	SCREW THREAD ROLLING
10		1	GRILL
11	8-24-04139-1	1	PANEL FILTER
11*	56382789	1	PANEL FILTER WATER RESISTENT
12		4	NUT SELF L. 5/16"UNC
13		4	NUT SELF L. M8 UNI7473
14		8	WASHER M8 UNI6592
15	33017118	1	PLATE LOCK SHAKER
16	33017119	1	FRAME PANEL FILTER
17		4	SCREW 5/16"X4,5" UNC
18	33018634	1	GASKET FILTER ASSY L 2560
19		2	CLAMP
20	33017232	1	MOTOR FILTER SHAKER 48V (M2)
21	9098257000	4	NUT THUMB SQUEEGEE FIXING
22	33021181	2	SEAL EDGE PROTECTOR KIT
[23]	33018804	1	FIXING ELECTROFAN KIT (ITEM 1-2-3-5-6-7)
[24]	33018805	1	GRILL ELECTROFAN KIT (ITEM 9-10)
[25]	33020335	1	PANEL FILTER HARDWARE KIT (ITEM 19-17-14-13-12)
[26]	33019259	1	ANTISTATIC KIT - TSB IT 2010-046
	33019261	1	INSTRUCTIONS ASSEMBLY

RT SIDE BROOM ASSY

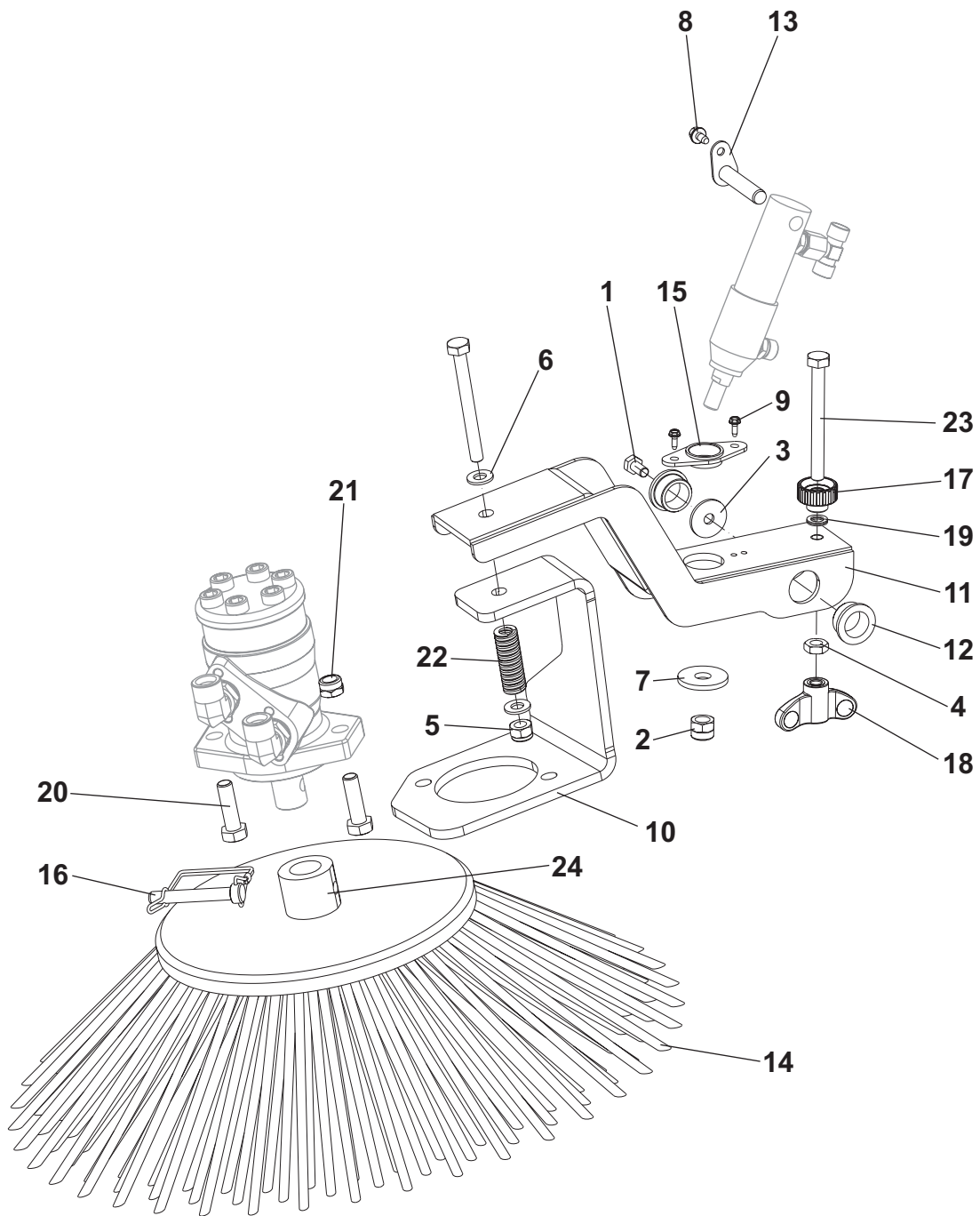

RT SIDE BROOM ASSY

ITEM	REF. NO.	QTY	DESCRIPTION
1		1	SCREW M8X16 UNI5739
2		1	NUT SELF L. M12 UNI7473
3		1	WASHER 8X32 UNI6593
4		1	NUT HEX M10 UNI5589
5		1	NUT SELF L. M10 UNI7473
6		2	WASHER M10 UNI6592
7		1	WASHER 12X40X4
8		1	SCREW THREAD ROLLING
9		2	SCREW THREAD ROLLING
10	33017107	1	SUPPORT RIGHT SIDE MOTOR
11	33017115	1	ARM SIDE BROOM
12		2	BUSH
13		1	PIN
14	33021313	1	SIDE BROOM ATLANTIS PPL
14	33017255	1	BROOM SIDE PPL 1,4-1,7
14*	33018889	1	BROOM SIDE PPL 1,5/STEEL
14*	33018890	1	BROOM SIDE NYLON 0,5
15		1	BUSHING SLIDE FLANGE
16	33022876	1	PIN CLEVIS W/LOOP 8MM
17	33017889	1	KNOB M10
18	33018333	1	NUT WING M10
19		1	WASHER NORD LOCK M10
20		2	SCREW M12X40 UNI5739
21		2	NUT SELF L. M12 UNI7474
22	146 1317 000	1	SPRING
23		2	SCREW M10X100 UNI5739
24	33020628	1	HUB BROOM
[25]	33020336	1	SUPPORT HARDWARE KIT (ITEM 23-21-20-22-6-5-4)
[26]	33020337	1	SIDE BROOM CYLINDER HARDWARE KIT (ITEM 15-13-9-8-7-2)
[27]	33020338	1	SETTING SIDE BROOM HARDWARE KIT (ITEM 23-19-18-17-7-1-3-12)

LT SIDE BROOM ASSY

ITEM	REF. NO.	QTY	DESCRIPTION	
1		1	SCREW M8X16 UNI5739	
2		1	NUT SELF L. M12 UNI7473	
3		1	WASHER 8X32 UNI6593	
4		1	NUT HEX M10 UNI5589	
5		1	NUT SELF L. M10 UNI7473	
6		2	WASHER M10 UNI6592	
7		1	WASHER 12X40X4	
8		1	SCREW THREAD ROLLING	
9		2	SCREW THREAD ROLLING	
10	33017115	1	ARM SIDE BROOM	
11		2	BUSH	
12	33017117	1	SUPPORT LEFT SIDE MOTOR	
13		1	PIN	
14	33021313	1	SIDE BROOM ATLANTIS PPL	
14	33017255	1	BROOM SIDE PPL 1,4-1,7	
14*	33018889	1	BROOM SIDE PPL 1,5/STEEL	
14*	33018890	1	BROOM SIDE NYLON 0,5	
15		1	BUSHING SLIDE FLANGE	
16	33022876	1	PIN CLEVIS W/LOOP 8MM	
17	33018807	1	MOTOR SIDE BROOM KIT	
18	33017889	1	KNOB M10	
19	33018333	1	NUT WING M10	
20	33021766	1	LEFT SIDE BROOM CYLINDER KIT (ITEM 28-29-30-31-32)	
21		1	WASHER NORD LOCK M10	
22		2	SCREW M12X40 UNI5739	
23		2	NUT SELF L. M12 UNI7474	
24	146 1317 000	1	SPRING	
25		2	SCREW M10X100 UNI5739	
26	33017003	1	MOTOR SIDE BROOM	
*	33020754	1	GASKETS HYDRAULIC MOTOR SIDE BROOM	
27	33015874	2	ELBOW 90 M1/2	
#	28	33021255	1	MICRO CYLINDER
#	*	33022009	2	GASKET MICRO CYLINDER
29	33018375	1	FITTINGS 1/8"	
30	33018222	1	FITTING 1/8	
31	33018215	1	DOWEL M5X6 DIAM 0,5	
32	146 0507 000	1	PIPE FITTING T D.10	
33	33020628	1	HUB BROOM	
[34]*	33019173	1	LEFT SIDE BROOM KIT	
	33018767	1	INSTRUCTIONS ASSEMBLY	
[36]	33020336	1	SUPPORT HARDWARE KIT (ITEM 25-23-21-22-6-5-4)	
[37]	33020337	1	SIDE BROOM CYLINDER HARDWARE KIT (ITEM 15-13-9-8-7-2)	
[38]	33020338	1	SETTING SIDE BROOM HARDWARE KIT (ITEM 23-19-18-7-1-3-11)	

MAIN BROOM SYSTEM

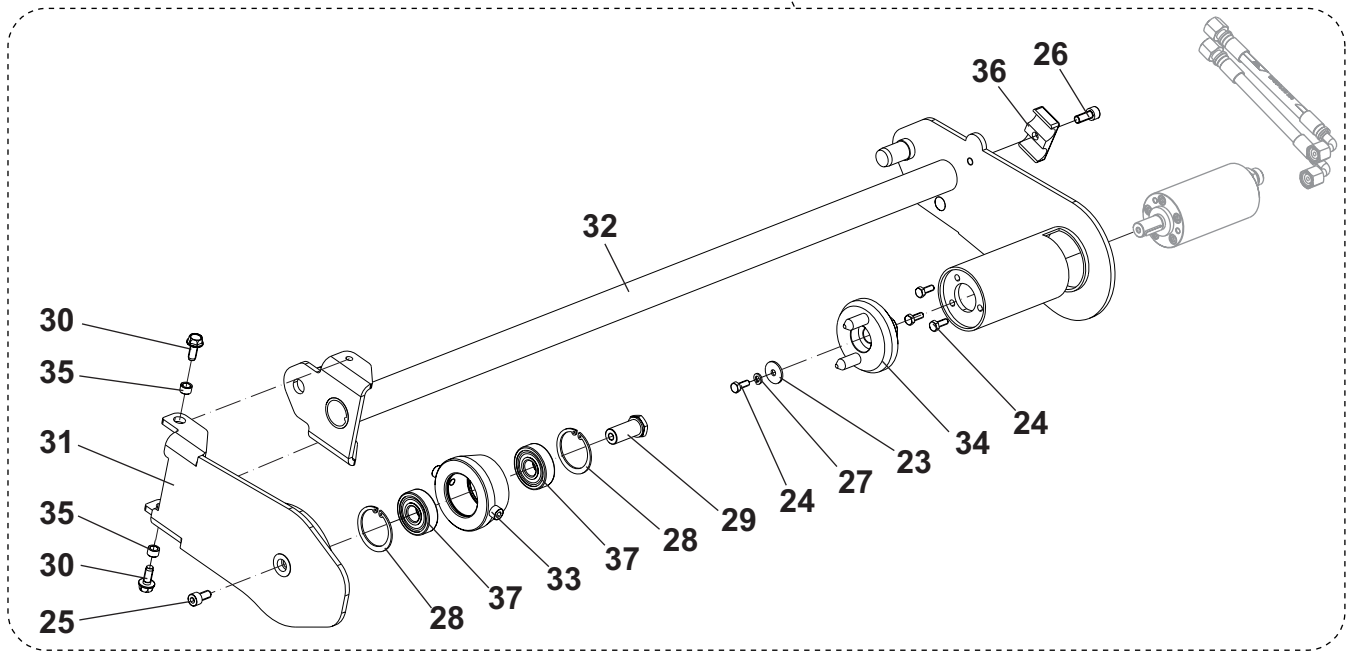
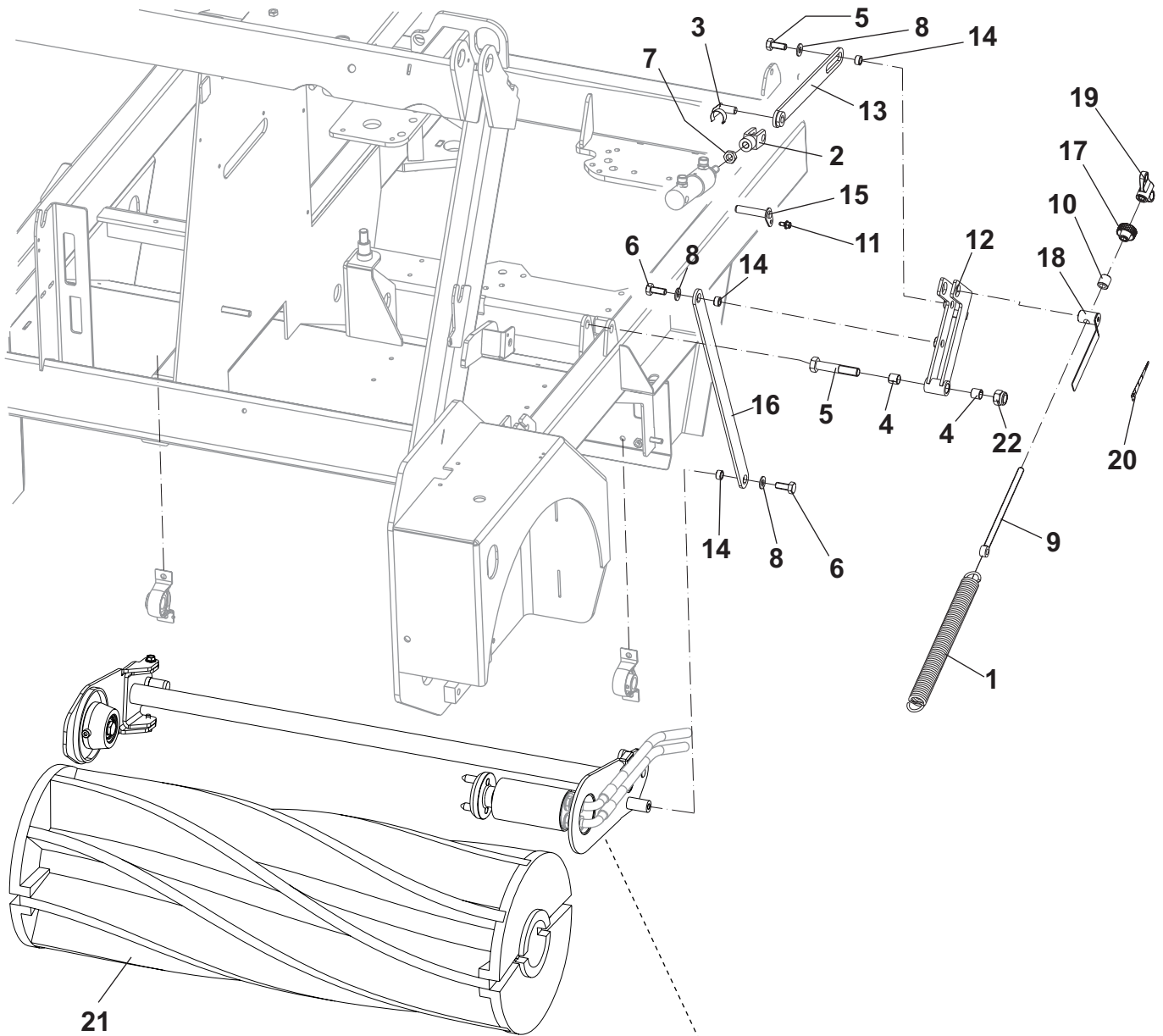

MAIN BROOM SYSTEM

	ITEM	REF. NO.	QTY	DESCRIPTION
	1	33002106	1	SPRING MAIN BROOM
	2		1	FORK M12
	3		1	CLIP 12
	4		2	BUSHING DU 14X16X15
	5		1	SCREW M14X70 UNI5737
	6		3	SCREW M10X25 UNI5739
	7		1	NUT HEX M12 UNI5589
	8		3	WASHER M10 UNI6592
	9		1	TIE ROD M10 L170
	10		1	SPACER D11 H18
	11		1	SCREW THREAD ROLLING
	12		1	LEVER WELDED
	13		1	CABLE
	14		3	SPACER
	15		1	PIN
	16		1	BAR
	17		1	KNOB M10
	18		1	PIN LEVER MAIN BROOM
	19		1	NUT WING M10
	20		1	DECAL PRESSURE MAIN BROOM
	21	33018858	1	BROOM MAIN SPIRAL PPL 0.5 WHITE NAVY/STEEL 0.36
	21*	33018856	1	BROOM MAIN SPIRAL NYLON 1.2
	21*	33018857	1	BROOM MAIN SPIRAL PPL 0.5 WHITE NAVY
	21*	33018859	1	BROOM MAIN SPIRAL UNION MIX
	22		1	NUT SELF L. M14 UNI7473
	23		1	WASHER 6X24 UNI6593
	24		4	SCREW M6X16 UNI5739
	25		1	SCREW M8X16 UNI5931
	26		1	SCREW M8X20 UNI5931
	27		1	WASHER M6 UNI1751B
	28		2	RING D 47 UNI7437
	29		1	PIN
	30		2	SCREW THREAD ROLLING
	31	33017007	1	BROOM ARM WELDED
	32	33017019	1	SUPPORT WELDED
	33	33017140	1	MAIN BROOM IDLE HUB
	34	33017141	1	HUB
	35		2	SPACER
	36		1	COLLAR DOUBLE D.18
#	37	33003162	2	BEARING 6303 2RS
	[38]	33018871	1	SUPPORT MOTOR KIT (ITEM 30-31-32-35-26-36)
	[39]	33018870	1	BALL BEARING KIT (ITEM 37-23-24-25-27-28-29-33-34)
	[40]	33018865	1	PLATE MAIN BROOM KIT (ITEM 2-3-6-8-7-15-13-14-11)
	[41]	33018868	1	LEVER WELDED KIT (ITEM 12-22-5-4)
	[42]	33018867	1	ROD SPRING KIT (ITEM 9-10-17-18-19-20)
	[43]	33018869	1	ROD LEVER KIT (ITEM 16-6-8-14)

ASSY CONTROL

	ITEM	REF. NO.	QTY	DESCRIPTION
	1	8-33-02360	1	HOLE HEAT SHIED
	2		2	SCREW M4X12 UNI7687
	3		2	SCREW 6X25
	4		4	WASHER 6X18 UNI6593
	5		6	WASHER 8X32 UNI6593
	6		2	SCREW M6X12 UNI5739
	7		3	SCREW M8X35 UNI5739
	8		3	SCREW M8X25 UNI5933
	9		8	NUT SELF L. M8 UNI7473
	10		1	WASHER M6 UNI8842A
	11	33009017	1	HORN 48V (HN)
	12		2	SCREW THREAD ROLLING
	13		1	SCREW THREAD ROLLING
	14		8	SCREW THREAD ROLLING
	15	33017053	1	DECAL MANIFOLD BATTERY
	16	33017164	1	FLAP LEVER COVER
	17	33017169	1	COVER SIDE ROTOMOLD
	17	33021154	1	WATER TANK KIT
	18	33017224	1	COVER PLATE NON TILT
	19	33017246	1	PLATE
	20	33017256	1	CONSOLE
	21	33017263	1	PLATE
	22	33017264	1	SUPPORT LEFT
	23	33017291	1	PLATE MANIFOLD BATT MACH
	24		13	SCREW 4.8X16 UNI6954
	25		2	SCREW M8X35 UNI5933
	26	33017376	1	HARNESS MAIN BATTERY
	27		7	SCREW M5X16 UNI7687
	28	146 2517 000	1	CHOCK RUBBER
	29	909 5836 000	3	CAP
	30	33018170	1	STEERING WHEEL
	31		1	LATCH
	34	33018803	1	LATCH KIT (ITEM 31-2-24)
	[35]	33020341	1	CONTROL LEFT HARDWARE KIT (ITEM 24-14-13-9-7-5-2)
	[36]	33020342	1	CONTROL RIGHT HARDWARE KIT (ITEM 27-25-24-14-13-12-10-9-8-7-6-5-4-3-2)
#	37A	33023039	1	BUZZER REVERSE GEAR BATTERY KIT
		33019168	1	INSTRUCTIONS ASSEMBLY
#	38	33023041	1	BRACKET F SENSOR US BATTERY VERSION PKD
	39	33010427	1	MICROSWITCH (SW4)
	40	33020544	1	MAT BATTERY RIGHT
	41	33020545	1	MAT BATTERY LEFT
	A:	UP TO S/N 3810134500024 - CODE 33022405 NO MORE AVAILABLE SEE TSB FC 2013-148		

PEDALS SYSTEM

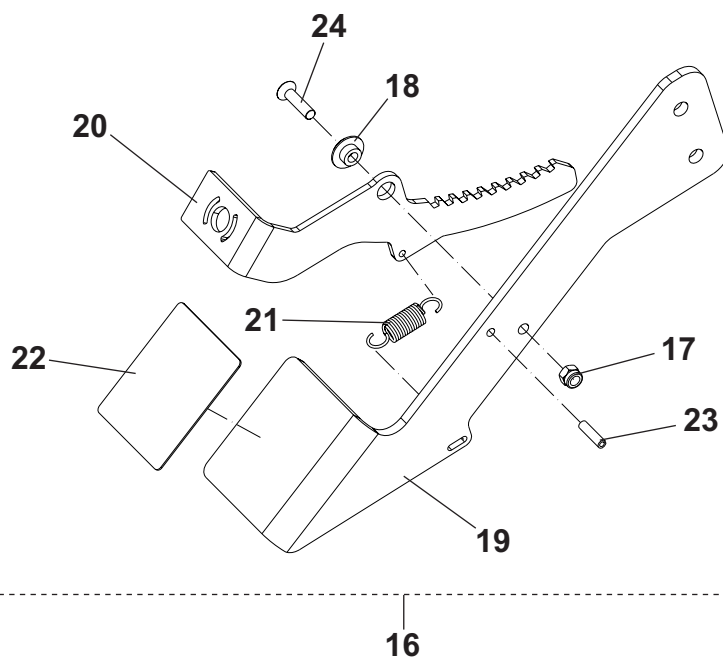
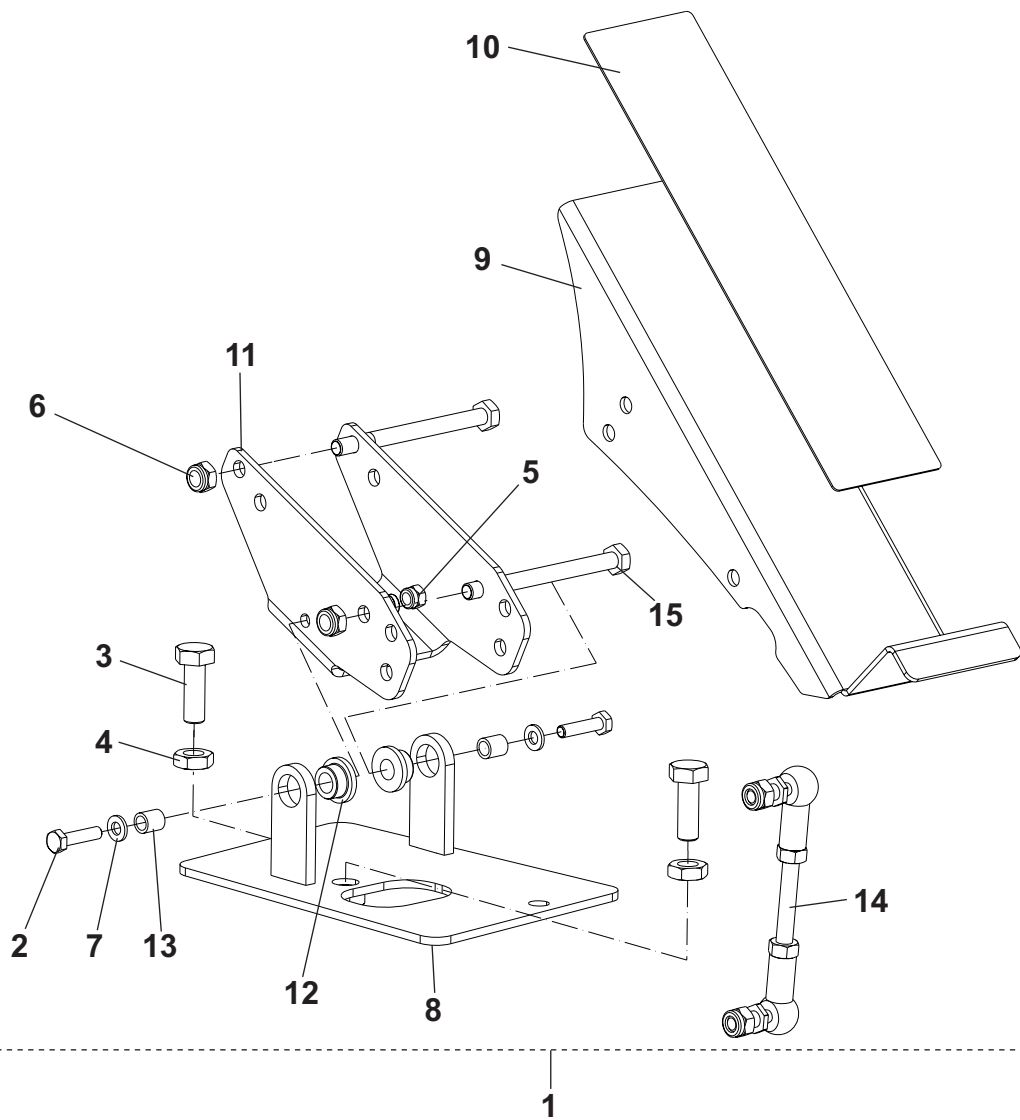

PEDALS SYSTEM

ITEM	REF. NO.	QTY	DESCRIPTION
1	33018841	1	FOOT PEDAL UPPER KIT (ITEM 2-3-4-5-6-7-8-9-10-11-12-13-14-15-25)
2		2	SCREW M6X25 UNI5739
3		1	SCREW HEX M10X35 UNI5739
4		2	NUT HEX M10 UNI5589
5		2	NUT SELF L. M6 UNI7473
6		2	NUT SELF L. M8 UNI7474
7		2	WASHER M6 UNI6592
8	33017203	1	MOUNT WELDED PEDAL
9	33017204	1	FOOT PEDAL UPPER
10	33017205	1	MAT PEDAL
11	33017206	1	FOOT PEDAL LOWER
12	33017216	2	BEARING
13	33017217	2	BUSHING
14	33018842	1	CONNECTION PEDAL KIT (ITEM 26-27-28-29)
15		2	SCREW M8X95 UNI5737
16	33018845	1	PEDAL BRAKE KIT (ITEM 17-18-19-20-21-22-23-24)
17		1	NUT SELF L. M6 UNI7473
18	33017178	1	BUSH
19	33017197	1	PEDAL BRAKE
20	33017198	1	PARKING BRAKE LEVER
21	33017199	1	SPRING
22	33017259	1	MAT PEDAL
23		1	PIN SPRING 5X20
24		1	SCREW M6X25 UNI5933
[25]	33020416	1	PEDAL WARDWARE KIT (ITEM 3-12-7-6-5-4-3-2)
[26]		2	NUT HEX M8 UNI5588
[27]		2	DADO AUTOB M8
[28]		1	BARRA FILETTATA
[29]		2	JOINT BALL M8

ASSY SPEED LIMITING

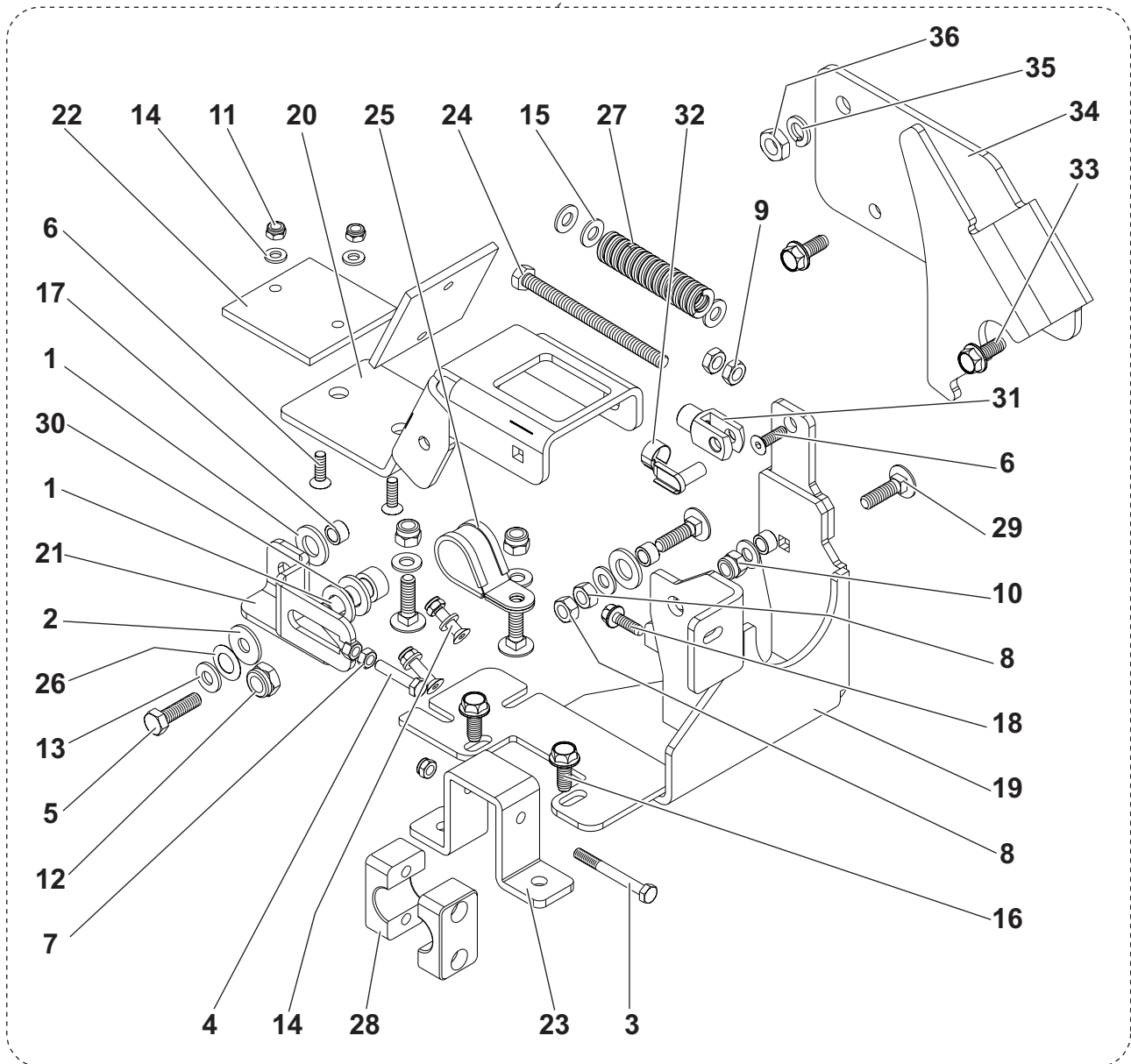
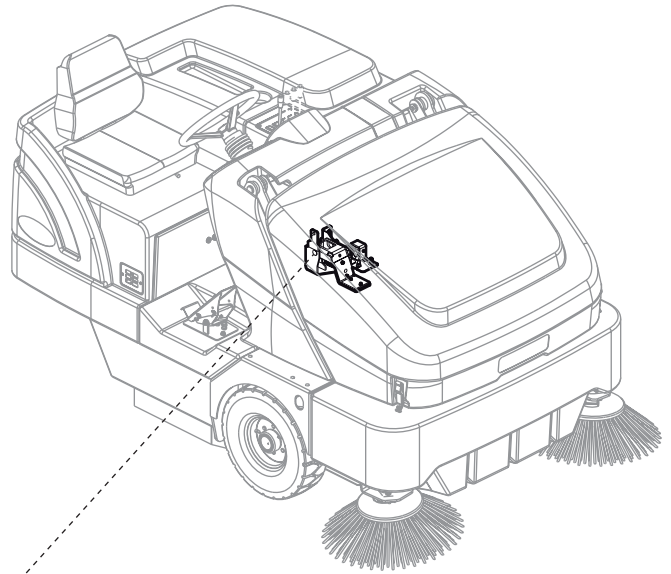

ASSY SPEED LIMITING

ITEM	REF. NO.	QTY	DESCRIPTION
1		4	WASHER M12 UNI6592
2		1	WASHER 8X24 UNI6593
3		1	SCREW M6X55 UNI5737
4		1	SCREW M6X30 UNI5739
5		1	SCREW M8X30 UNI5739
6		5	SCREW M6X20 UNI5933
7		1	NUT HEX M6 UNI5588
8		2	NUT HEX M8 UNI5588
9		2	NUT HEX M8 UNI5589
10		3	NUT SELF L. M8 UNI7473
11		5	NUT SELF L. M6 UNI7474
12		1	NUT SELF L. M10 UNI7474
13		1	WASHER M8 UNI8836
14		4	WASHER M6 UNI6592
15		7	WASHER M8 UNI6592
16		2	SCREW THREAD ROLLING
17		3	SPACER
18		1	SCREW THREAD ROLLING
19	33019995	1	BASE SPEED LIMITING
20	33019996	1	LEVER SPEED LIMITING
21	33019997	1	LEVER ADJUSTER
22	33019998	2	PLATE FOR SPEED LIMITING
23	33020212	1	SUPPORT COLLAR
24		1	SCREW M8X110 UNI5739
25	33020367	1	CLAMP HOSE D.25
26	146 0617 000	1	BELLEVILLE WASHER
27		1	SPRING
28		1	COLLAR.PIPE FIXING D.22
29		4	SCREW M8X30 UNI5731
30		1	SCREW SHOULDER M12X16
31		1	FORK M8
32		1	KLIPP M8
33		4	SCREW THREAD ROLLING
34	33020565	1	BRACKET SAFETY GUIDE
35		1	WASHER M10 UNI1751B
36		1	NUT HEX M10 UNI5589
[37]	33020350	1	SPEED LIMITING HARDWARE KIT (ITEM 1-2-3-4-5-6-7-8-9-10-11-12-13-14-15-16-17-18-24-27-28-29-30-31-32)

ELECTRIC BOX ASSY

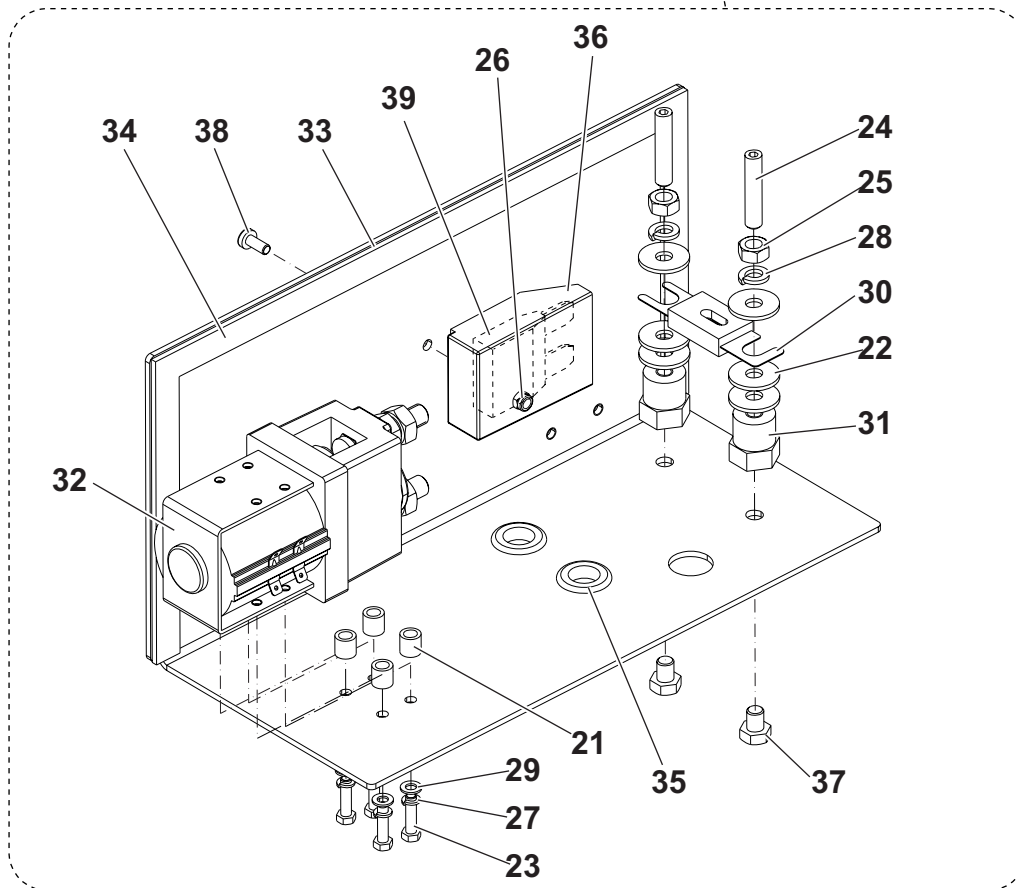
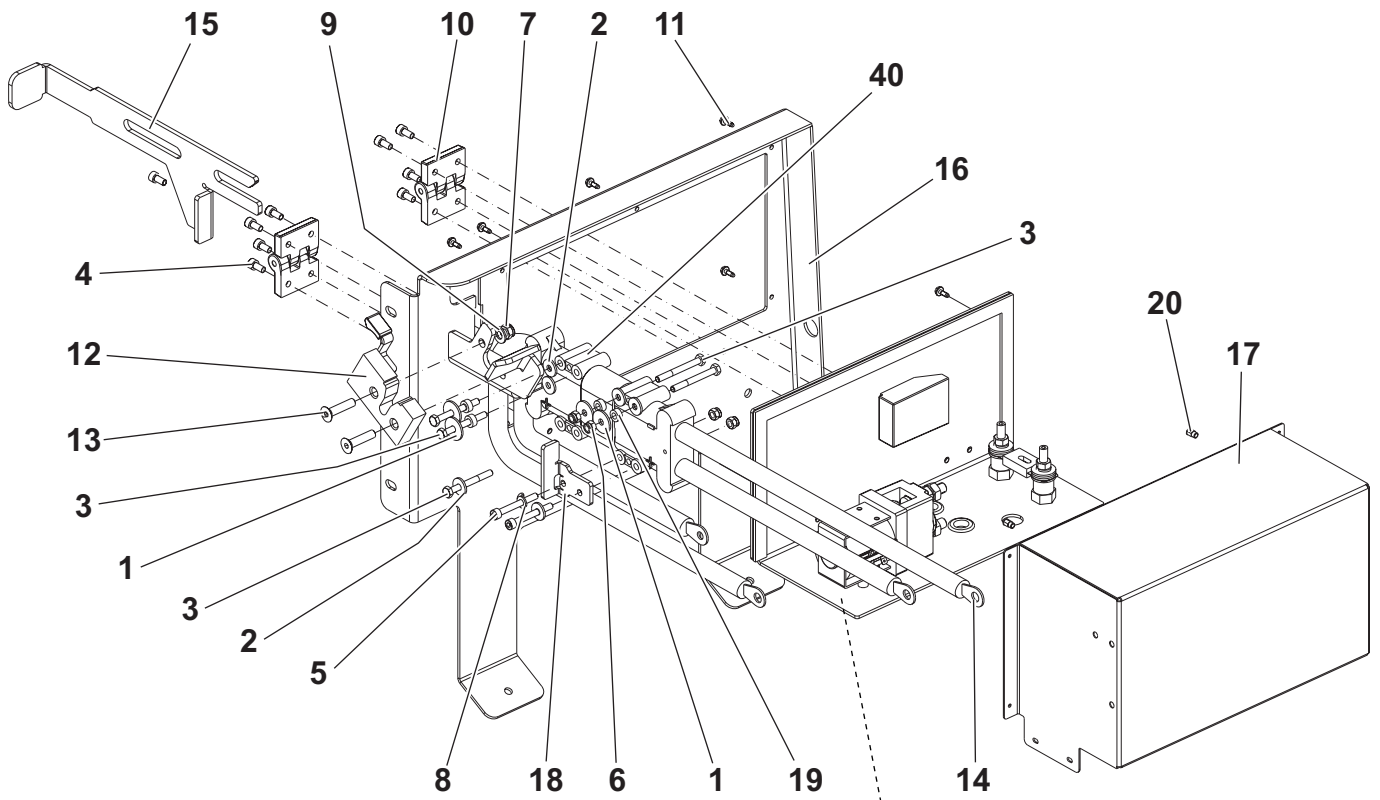

ELECTRIC BOX ASSY

ITEM	REF. NO.	QTY	DESCRIPTION
1		4	WASHER 6X24 UNI6593
2		6	WASHER 6X18 UNI6593
3		5	SCREW M6X55 UNI5737
4		8	SCREW M6X12 UNI5931
5		2	SCREW M6X50 UNI5931
6		4	NUT SELF L. M6 UNI7473
7		2	NUT SELF L. M8 UNI7474
8		1	WASHER M6 UNI6592
9		2	WASHER M8 UNI6592
10	33009531	2	HINGE
11		7	SCREW THREAD ROLLING
12	33017176	1	LATCH SLAM
13		2	SCREW M8X35 UNI5933
14	33017362	1	HARNESS ELECTRIC MOTOR
15	33017393	1	PLATE
16	33017680	1	PLATE
17	33017683	1	BOX
18	33020297	1	BRACKET EMERGENCY DISCONN
19		4	SPACER
20		2	INSERT M4
21		4	SPACER
22		6	WASHER 8X24 UNI6592
23		4	SCREW M5X20 UNI5739
24		2	SCREW GRUB M8X40 UNI5923
25		2	NUT HEX M8 UNI5588
26		1	NUT SELF L. M5 UNI7474
27		4	WASHER M5 UNI1751B
28		2	WASHER M8 UNI1751B
29		4	WASHER M5 UNI6592
30	33008583	1	POWER FUSE 250A (F0)
31	33017365	2	ISOLATOR M8
32	33017449	1	CONTACTOR UNIPOLAR 48V (ES0)
33	33017681	1	COVER
34	33018876	1	GASKET L 2500
35		2	GROMMET
36	146 0659 000	1	FUSE HOLDER MAXIVAL
37		2	SCREW M8X10 UNI5739
38		1	SCREW M5X12 UNI7687
39	909 5101 000	1	FUSE 30A (F10)
40	33019166	1	CONNECTOR 350 AMP BLUE (C1)
[41]	33018861	1	BLOCK BONNET KIT (ITEM 12-9-7-18-21-2- SEE PAGE 31 12-13)
[42]	33020449	1	ELECTRIC BOX HARDWARE KIT (ITEM 1-2-3-4-5-6-7-8-9-11-13-19-20-21-22-23-24-25-26-27-28-29-37-38)

ASSY CONTROL PANEL AND RELAYS

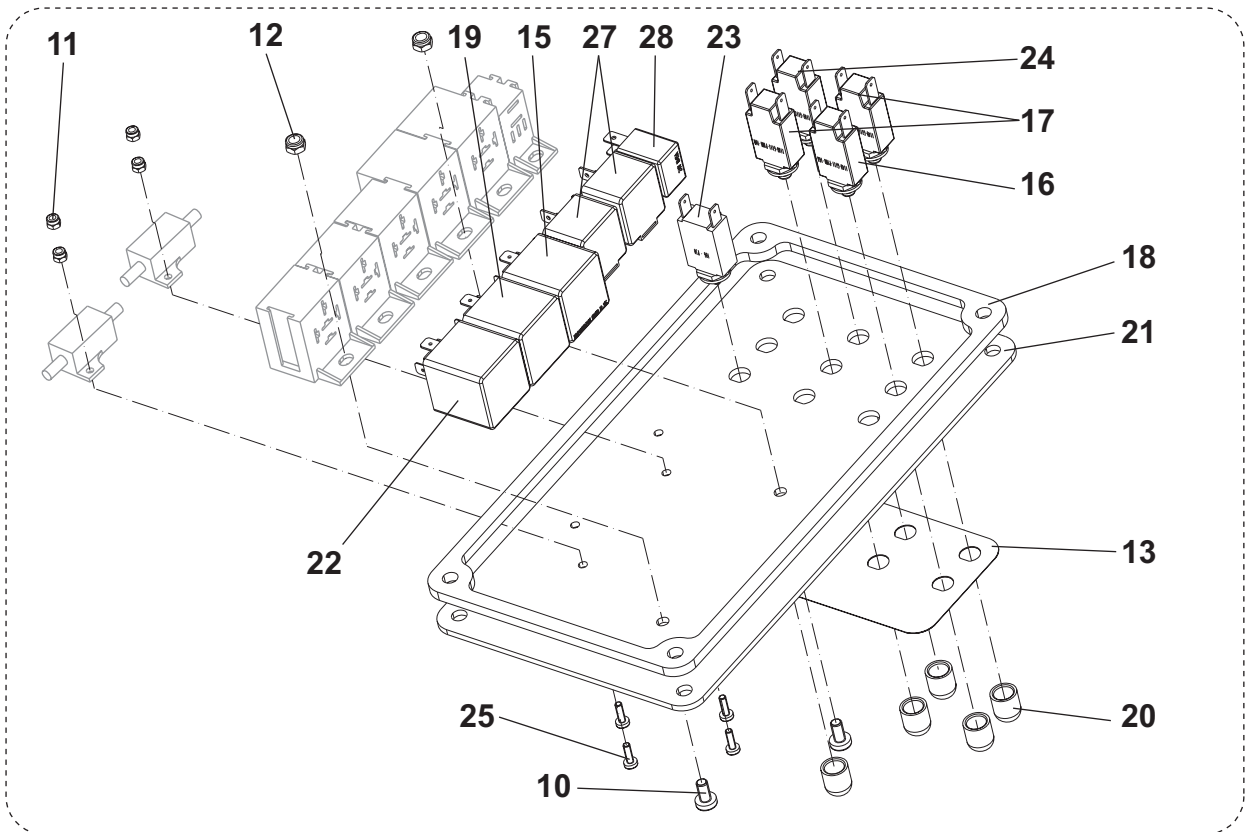
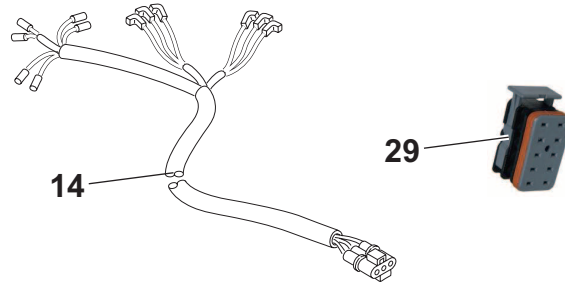
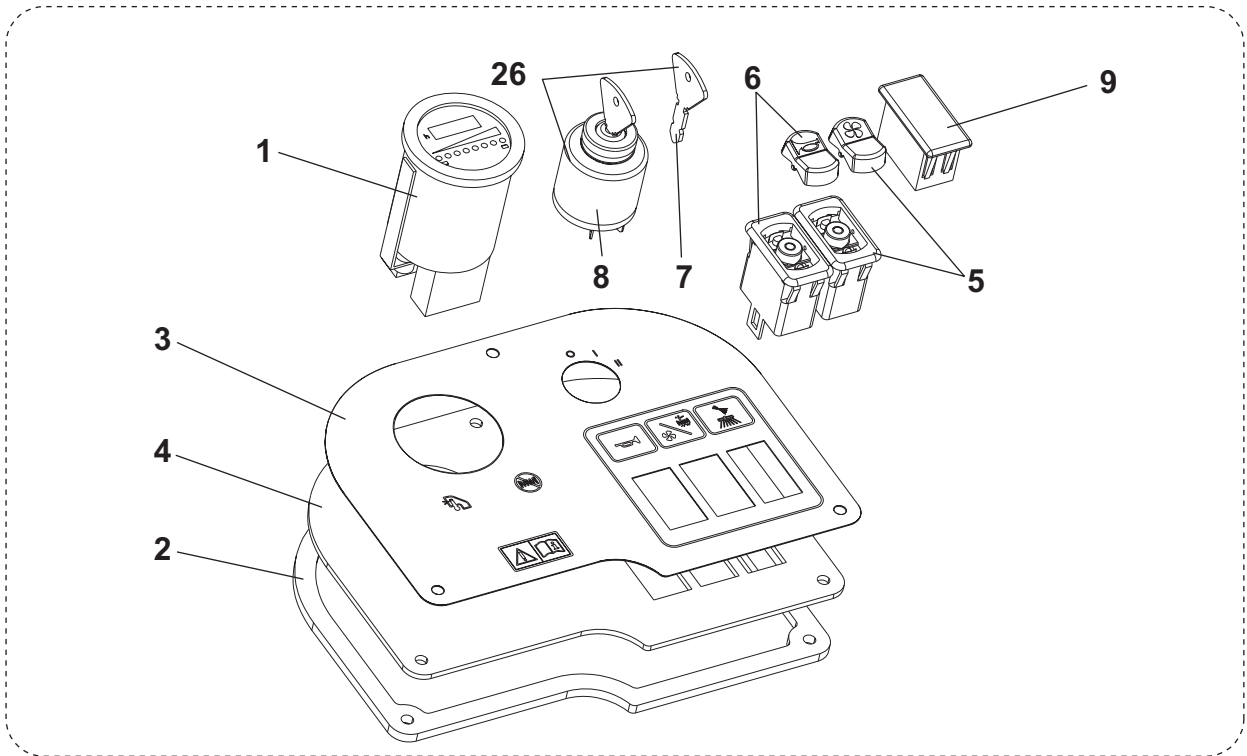

ASSY CONTROL PANEL AND RELAYS

ITEM	REF. NO.	QTY	DESCRIPTION
1	33017221	1	GAUGE 48V (STR)
2	33017223	1	GASKET PLATE
3	33017375	1	DECAL GAUGE PANEL
4	33017377	1	PLATE GAGE BATTERY
5	33018843	1	SWITCH SUCTION KIT (SW1)
6	33018844	1	SWITCH HORN KIT (SW2)
7	146 0073 00	1	KEY (1PC)
9	909 5836 000	1	CAP
10		2	SCREW PAN PHIL M5X10
11		4	NUT SELF L. M3 UNI7474
12		2	NUT SELF L. M5 UNI7474
13	33017249	1	DECAL FUSES
14	33017356	1	HARNESS RELAY (BATT)
15	33017359	1	RELAY TIMER 20 SECONDS (T1)
16	33017360	1	BREAKER CIRCUIT 16A (F4)
17	33017361	2	CIRCUIT BREAKER 10A (F1 - F5)
18	33017381	1	GASKET
19	33017385	1	RELAY TIMER 0,5 SEC. (T2)
20	33017386	5	BOOT CIRCUIT BREKER
21	33017414	1	PLATE FUSES
22	33019197	1	RELAY TIMER 0,5 SEC. (T3)
23	33020276	1	BREAKER CIRCUIT 3A
24	33020282	1	BREAKER CIRCUIT 5A (F2)
25		4	SCREW PAN PHIL M3X10
26	33020442	1	KEY START ASSY WITH SPARE KEY (ITEM 8-7)
27	909 6622 000	2	RELAY 24V 40A (ES1 - ES2)
28	146 1646 000	1	RELAY 24V (ES3)
29	33017330	3	SWITCH CONNECTOR

ASSY REAR COVER

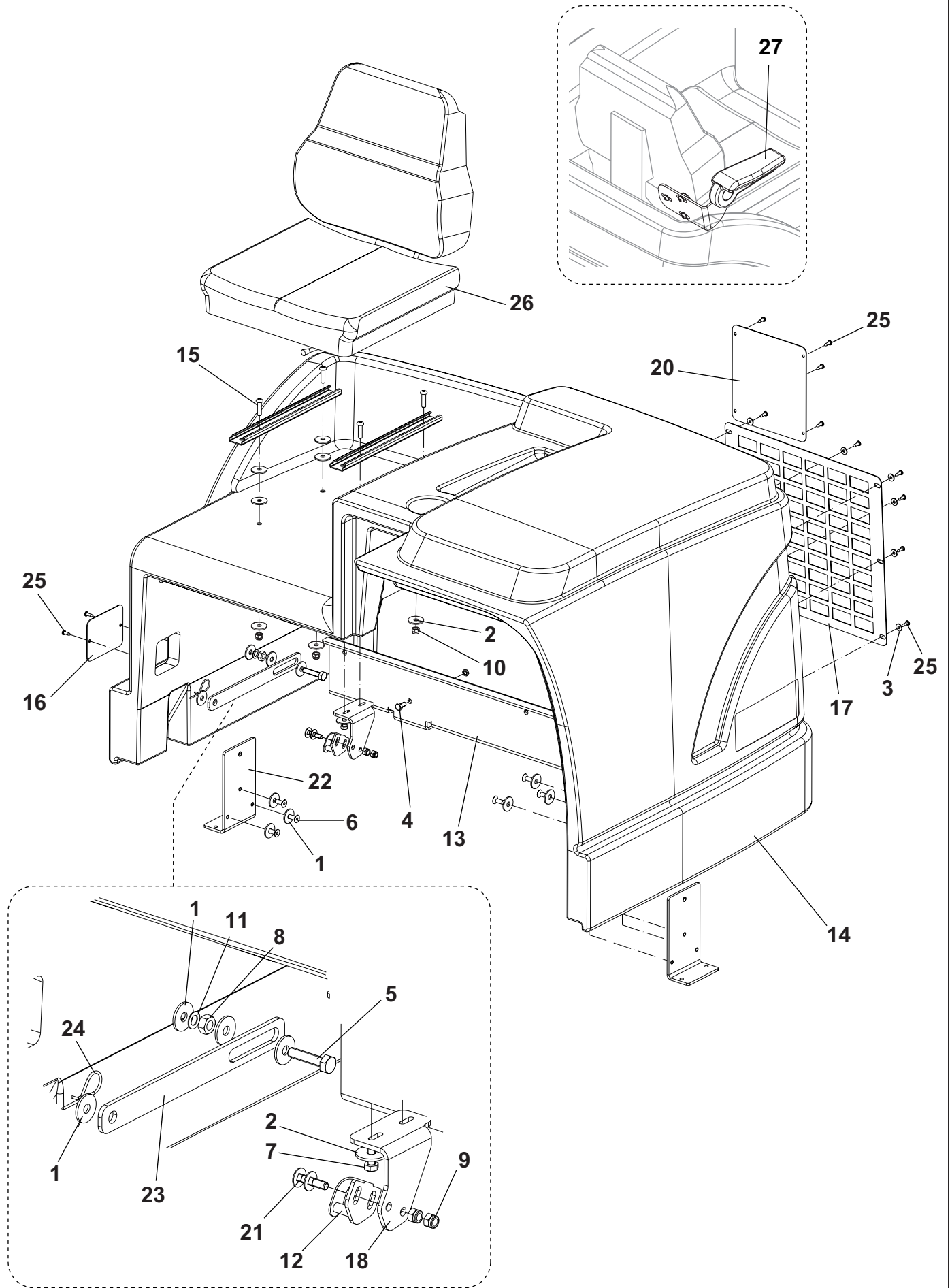

ASSY REAR COVER

	ITEM	REF. NO.	QTY	DESCRIPTION
	1		14	WASHER 10X30 UNI6592
	2		14	WASHER 8X32 UNI6593
	3		6	WASHER 5X15 UNI6593
	4		6	SCREW M8X16 UNI5739
	5		2	SCREW M10X45 UNI5739
	6		6	SCREW M8X20 UNI5933
	7		2	SCREW M8X20 UNI5739
	8		2	NUT HEX M10 UNI5588
	9		2	NUT SELF L. M8 UNI7473
	10		4	NUT SELF L. M8 UNI7474
	11		2	WASHER M10 UNI8842A
	12	33017177	1	CATCH LATCH
#	13	33017213	1	BRACKET HINGE
	14	33021009	1	COVER ENGINE
	15		4	SCREW M8X30 ISO7380
	16	33017245	1	PLATE SIDE SMALL BATTERY
	17	33017247	1	GRILL REAR
	18	33017261	1	PLATE CATCH
	[19]	33017357	1	HARNESS REAR COVER BATTERY
	20	33017368	1	PLATE SMALL BATTERY
	21		2	SCREW M8X20 UNI5732
	22	33018685	2	BRACKET FOR STOP COVER
	23	33018687	2	ROD CONNECTING STOP COVER
	24		2	PIN COTTER
	25		16	SCREW PAN HD
	26	145 5975 000	1	SEAT
	27	33019556	1	ARMREST RIGHT KIT
	[28]	33019554	1	SEAT BELT KIT
	[29]	33018862	1	BONNET BLOCK KIT (11-1-8-5-23-24)
	[30]	33019103	1	REINFORCEMENT BONNET KIT (1-4-6-13-22-25)
	[31]	33020340	1	REAR COVER HARDWARE KIT (ITEM 1-2-3-4-5-6-7-8-9-10-11-15-21-24-25)

ELECTRIC MOTOR ASSY

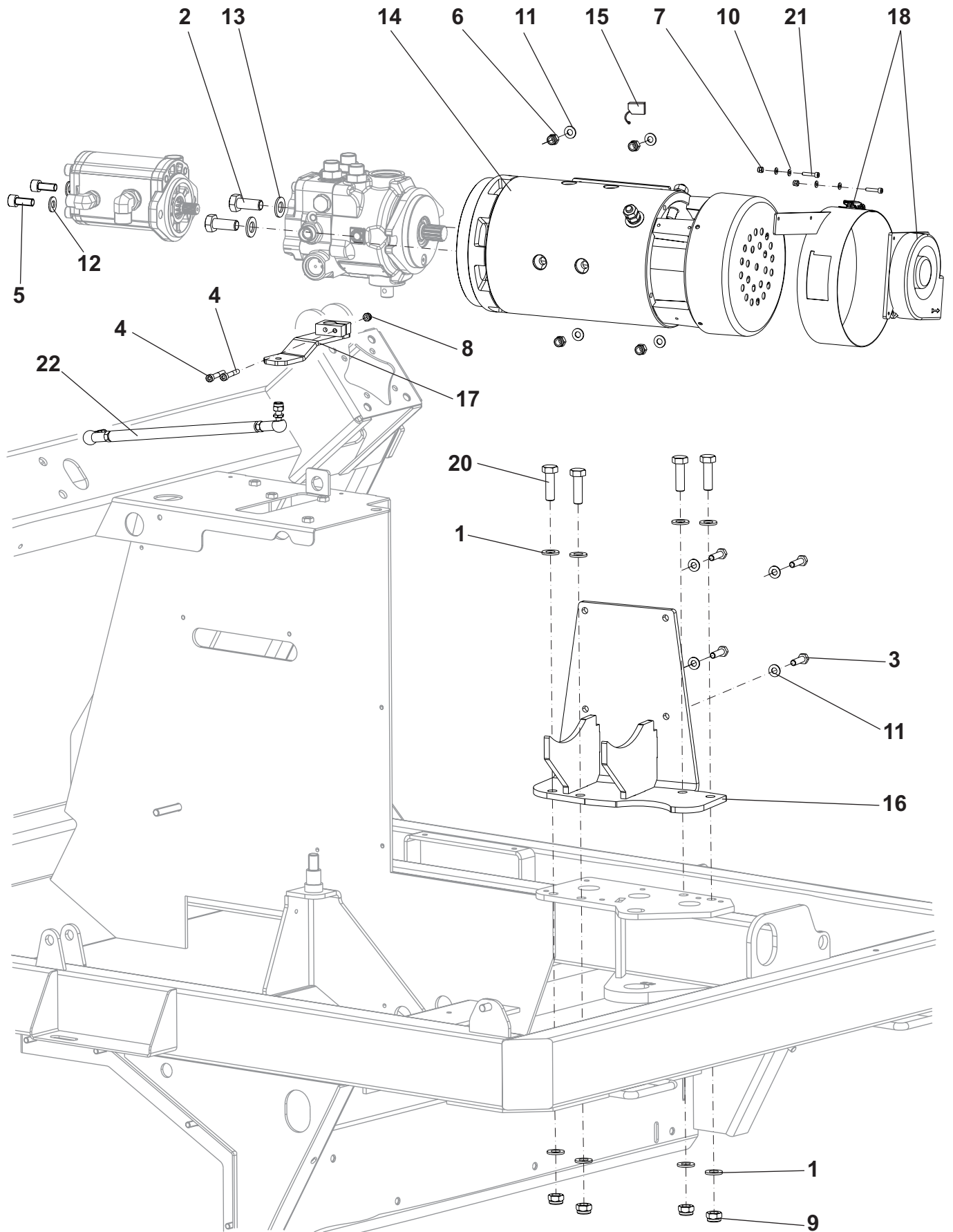

ELECTRIC MOTOR ASSY

ITEM	REF. NO.	QTY	DESCRIPTION
1		8	WASHER M12 UNI6592
2		2	SCREW M14X35 UNI5739
3		4	SCREW M8X30 UNI5739
4		2	SCREW M6X40 UNI5931
5		2	SCREW M10X25 UNI5931
6		4	NUT SELF L. M8 UNI7473
7		2	NUT SELF L. M4 UNI7473
8		1	NUT SELF L. M6 UNI7474
9		4	NUT SELF L. M12X1.5
10		4	WASHER M4 UNI6592
11		8	WASHER M8 UNI6592
12		2	WASHER M10 UNI6592
13		2	WASHER M14 UNI6592
14	33022549	1	MOTOR ELECTRIC AND CABLE EXTENTION KIT (MP)
15	33022548	1	CARBON BRUSH KIT 8 PCS
15C	33019625	1	CARBON BRUSH KIT 4PCS
16A	33017364	1	BRACKET
#	16B	33023028	1 BRACKET
17	33017382	1	LEVER PUMP BATTERY
#	18C	33023036	1 FAN COOLING MOTOR ELECTRIC KIT (M6)
20		4	SCREW M12X40 UNI5739
21		2	SCREW M4X20 UNI5931
22A	33020562	1	KIT LINKAGE PEDAL BATTERY
22B	33022170	1	KIT LINKAGE PEDAL BATTERY
[23]	33020450	1	ELECTRIC MOTOR HARDWARE KIT (ITEM 1-2-3-4-5-6-7-8-9-10-11-12-13-20-21)
A:	UP TO S/N 3810114600046		
B:	STARTING FROM S/N 3810114600047		
C:	ONLY FOR 33017260 ELECTRIC MOTOR 48V 7 KW		

ASSY HYDRAULIC PLANT

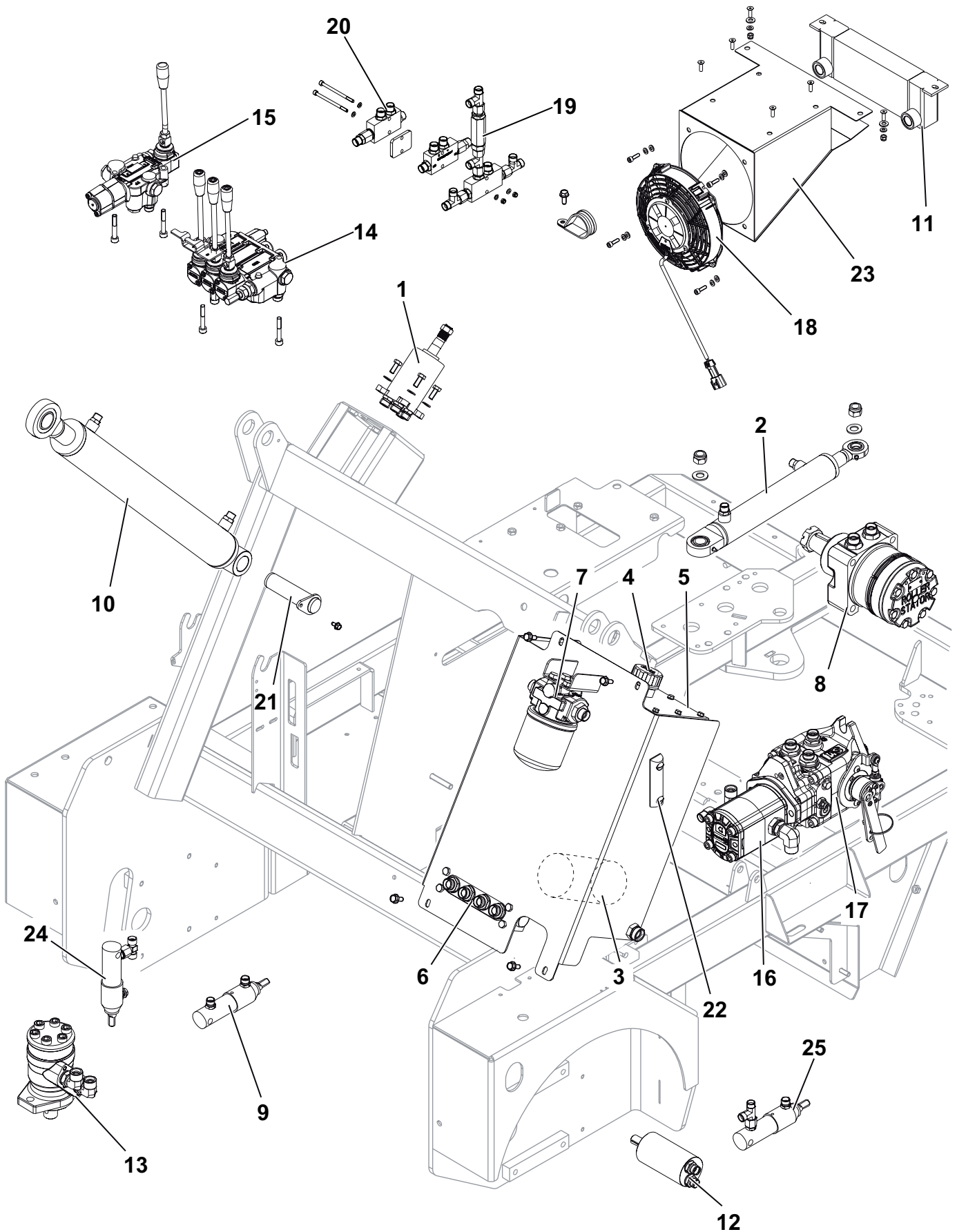

ASSY HYDRAULIC PLANT

ITEM	REF. NO.	QTY	DESCRIPTION
1	33022292	1	STEERING UNIT KIT
*	33022033	1	GASKET STEERING UNIT
2	33018808	1	CYLINDER POWER STEERING KIT (ITEM 23-2 SEE PAGE 39)
3	33010199	1	OIL FILTER HYDRAULIC
4	33011530	1	PLUG
5	33001307	1	GASKET
6	33018809	1	TANK OIL KIT (ITEM 22-17-20-21-19-18 SEE PAGE 37)
7	33018810	1	FILTER PRESSURE KIT (ITEM 10-11 SEE PAGE 37)
8	33019737	1	MOTOR DRIVE KIT (ITEM 21-22 SEE PAGE 39)
*	33020753	1	GASKETS HYDRAULIC MOT.KIT
9	33018802	1	CYLINDER FLAP KIT (13-14-15-16 SEE PAGE 37)
10	33018811	1	CYLINDER LIFTING CONTAINNE
10A	33021068	1	ADAPTATION FOR CYLINDER W
11	33022413	1	RADIATOR
12	33018872	1	MOTOR MAIN BROOM KIT (ITEM 8-1 SEE PAGE 37)
13	33018807	1	MOTOR SIDE BROOM KIT (ITEM 23-24 SEE PAGE 37)
14	33018812	1	DISTRIBUTOR 3 ELEMENTS KIT (ITEM 2-3-4-5-6-7 SEE PAGE 37)
15	33018815	1	DISTRIBUTOR 1 ELEMENT KIT (ITEM 1-7-9 SEE PAGE 37)
16		1	PUMP HYDRAULIC TWIN KIT (ITEM7-18-19-20-25 SEE PAGE 39)
17	33022111	1	PUMP DRIVE KIT (ITEM 24-26 SEE PAGE 39)
*	33022094	1	GASKET HYDRAULIC PUMP KIT
#	* 33023034	1	PINION FOR PUMP TRACTION P01 PKD
#	17B 33023029	1	PUMP AND SUPPORT MOTOR KIT
#	33023030		INSTALLATION INSTRUCTION
18	33020222	1	MOTOR VACUUM 48V (M5)
19	33018817	1	CUTOFF VALVE DOUBLE KIT (ITEM 6-12-13-14-15-16 SEE PAGE 39)
20	33018840	2	CUTOFF VALVE KIT (ITEM 10-2 SEE PAGE 39)
21	33020853	1	PIN HYDRAULIC CYLINDER
22	33011529	1	OIL LEVEL
23	33020265	1	CONVEYOR FOR AIR COOLER
24	33021767	1	CYLINDER BROOM RIGHT KIT (ITEM 13-14-15-25-26-27 SEE PAGE 37)
25	33021765	1	CYLINDER CENTRAL BROOM KIT (ITEM 5-6-7-8-9 SEE PAGE 39)
[26]	33020339	1	HYDRAULIC HARDWARE KIT (ITEM 27-28-29-30-31-32-33-34-35-36-37-38)
[27]		4	SCREW M8X20 ISO7380
[28]		4	CAP INSULATING
[29]		2	NUT SELF L. M14 UNI7473
[30]		1	CLAMP HOSE D.45
[31]		1	SCREW THREAD ROLLING
[32]		1	SCREW THREAD ROLLING
[33]		1	PIPE FITTING
[34]		2	WASHER M14 UNI6592
[35]		4	WASHER M5 UNI6592
[36]		4	NUT SELF L. M5 UNI7474
[37]		2	SCREW M5X80 UNI5931
[38]		2	SCREW M6X55 UNI5737
A:	FOR MACHINE AFTER S.N. 103206080 (ALONG WITH REF., 33018811)		
B:	33023029 - FOR MACHINE BEFORE S.N.3810121100106		

ASSY HYDRAULIC PLANT

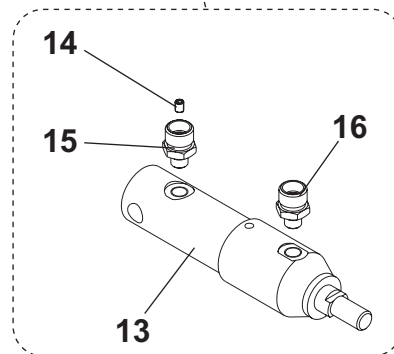
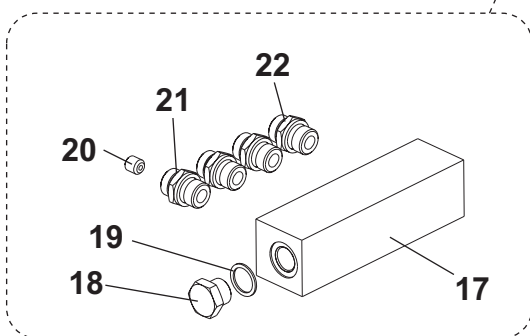
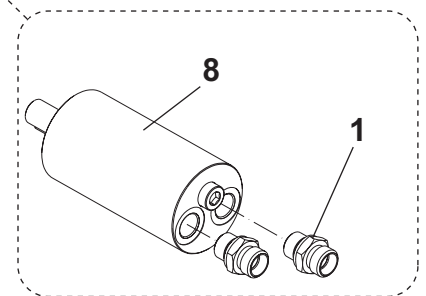
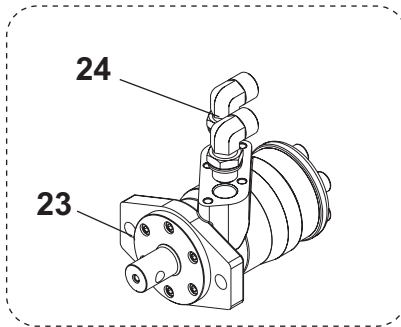
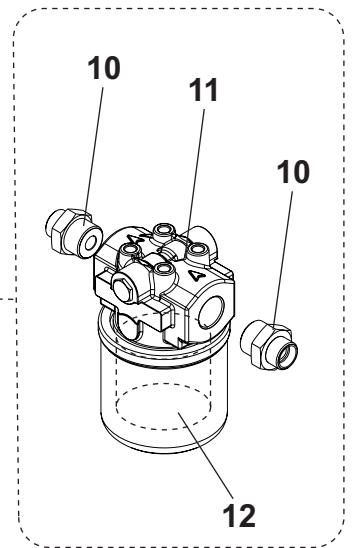
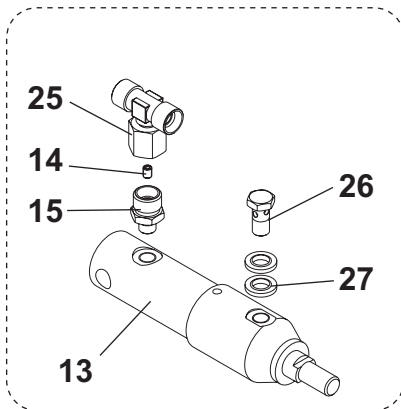
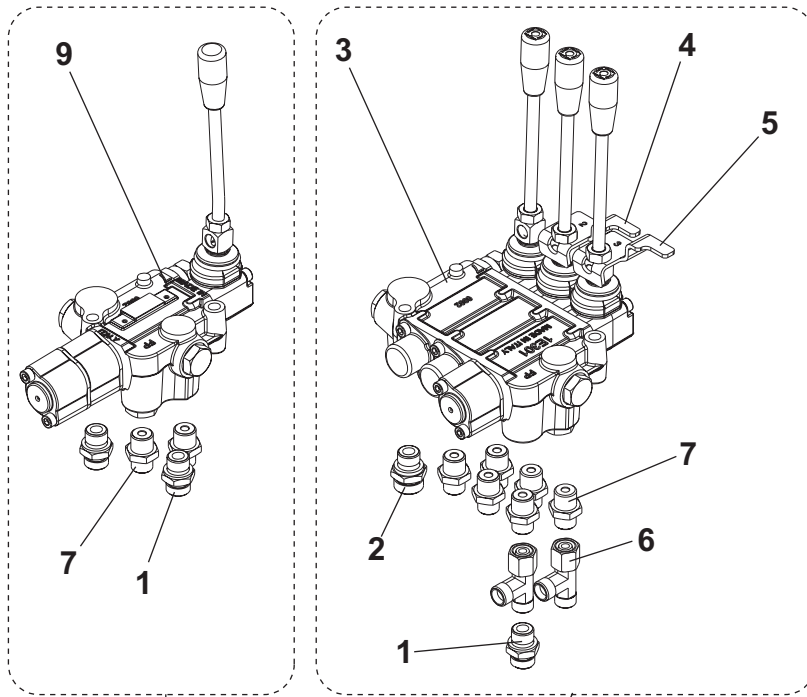

ASSY HYDRAULIC PLANT

	ITEM	REF. NO.	QTY	DESCRIPTION
	1	33015917	5	FITTINGS M3/8
	2	33016018	1	FITTINGS M3/8
	3	33017052	1	DISTRIBUTOR 3 ELEMENTS
	4	33017752	1	BRACKET
	5	33017753	1	BRACKET
	6	145 5163 000	2	PIPE FITTING
	7	146 0505 000	8	PIPE FITTING 3/8 D.10
#	8A	33023044	1	MOTOR HYDRAULIC 32 CC PKD
#	*A	33023043	1	GASKET MOTOR HYDRAULIC KIT
	*B	33020765	1	GASKET HYDRAULIC PUMP KIT
	9	33017676	1	DISTRIBUTOR 1 ELEMENT
	10	33015348	2	PIPE FITTING
	11	33017431	1	FILTER MEDIUM PRESSUR
	12	33017595	1	CARTRIDGE OIL FILTER
	13	33021255	2	MICRO CYLINDER
	*	33022009	2	GASKET MICRO CYLINDER
	14	33018215	2	DOWEL M5X6 DIAM 0,5
	15	33018222	2	FITTING 1/8
	16	33018375	1	FITTINGS 1/8"
	17	33017432	1	BLOCK HYD. HOSES
	18	33011456	1	CAP 1/2"
	19	145 4291 000	1	COPPER GASKET 1/2"
	20	33018675	1	DOWEL M12 DIAM 4
	21	33018676	1	PIPE FITTING 1/2 D.15
	22	33015757	3	FITTINGS M1/2
	23	33017003	1	MOTOR SIDE BROOM
	*	33020754	1	GASKETS HYDRAULIC MOTOR KIT
	24	33015874	2	ELBOW 90 M1/2
	25	146 0507 000	1	PIPE FITTING T D.10
	26	146 0093 00	1	SCREW W/HOLE 1/8
	27	145 6020 000	2	WASHER BONDED 1/8
	A:	STARTING FROM S.N. 091508810		
	B:	FOR MACHINE AFTER S.N. 103206080 (FOR REF. 33017004)		

ASSY HYDRAULIC PLANT

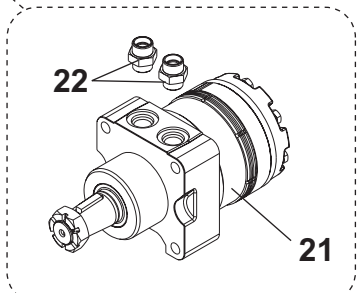
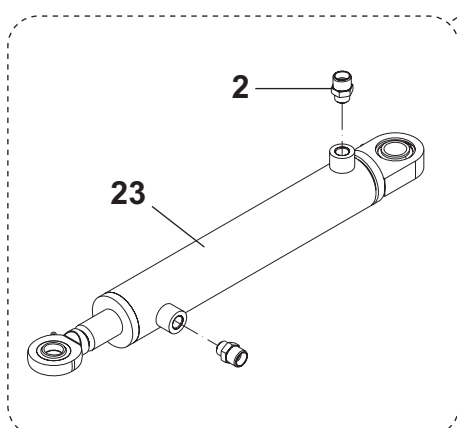
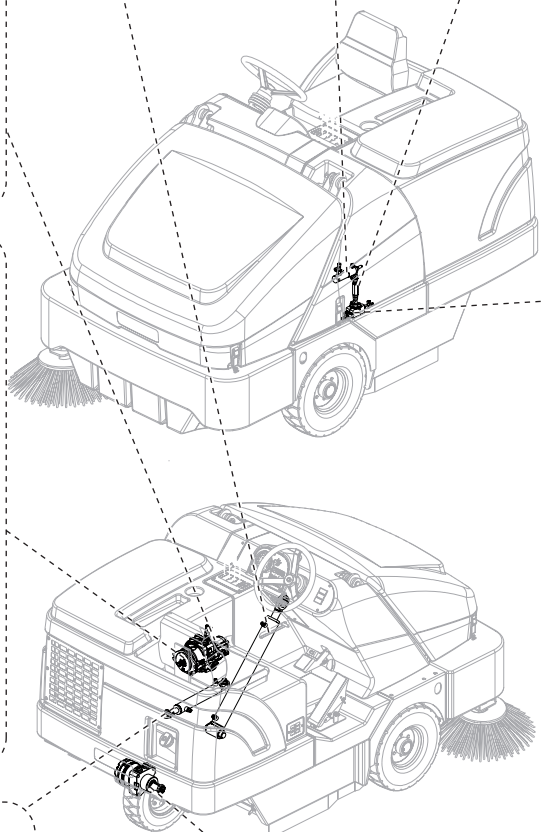
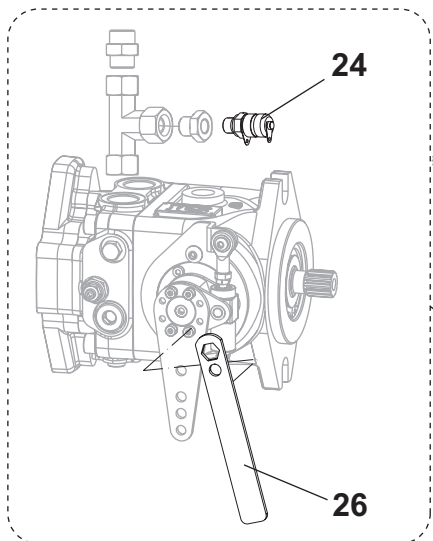
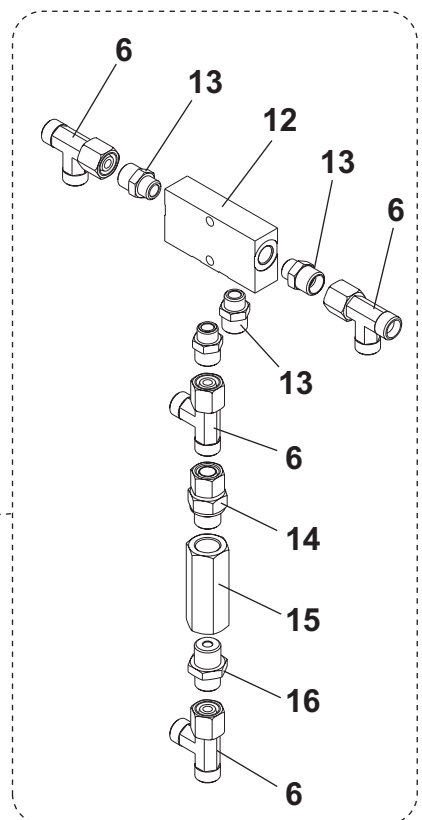
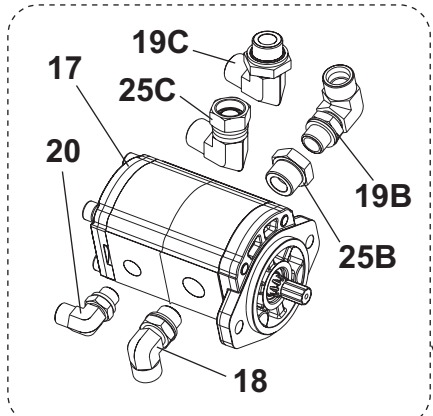
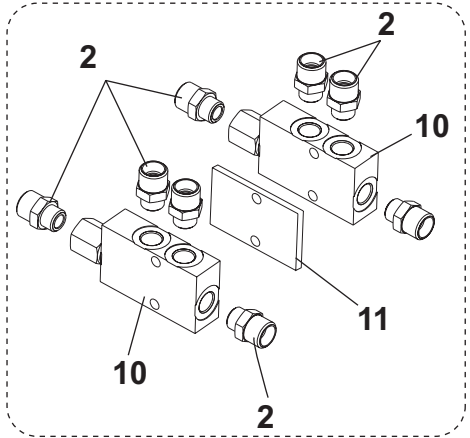
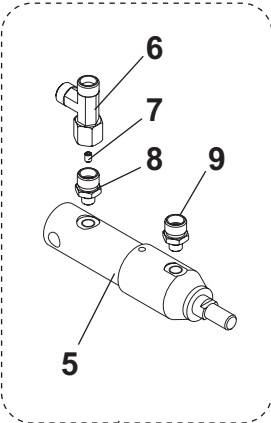
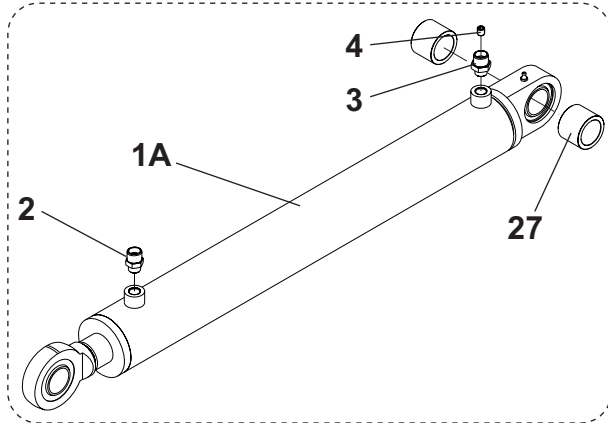

ASSY HYDRAULIC PLANT

ITEM	REF. NO.	QTY	DESCRIPTION
1A	33021257	1	CYLINDER HOPPER LIFT
*	33011777	1	GASKET CYLINDER KIT
2	146 2977 000	11	PIPE FITTING 1/4 D. 10
3	33018221	1	FITTING 1/4"
4	33019272	1	DOWEL M8X8 DIAM 1
5	33021255	1	MICRO CYLINDER
*	33022009	1	GASKET MICRO CYLINDER
6	145 5163 000	5	PIPE FITTING
7	33018215	1	DOWEL M5X6 DIAM 0,5
8	33018222	1	FITTING 1/8
9	33018375	1	FITTINGS 1/8"
10	33022294	2	VALVE SIMPLE CHECK
11	33019712	1	PLATE VALVES
12	33010486	1	CUTOFF VALVE 1/4
13	146 2977 000	4	PIPE FITTING 1/4 D. 10
14	33018220	1	FITTINGS M3/8"-F10L
15	33010481	1	VALVE 3/8 NONRETURN
16	146 0505 000	1	PIPE FITTING 3/8 D.10
17	33020224	1	PUMP HYDRAULIC TWIN
*	33020755	1	GASKETS HYDRAULIC MOT.KIT
18	33015874	1	ELBOW 90 M1/2
19B	33016362	1	ELBOW
19C	33022395	1	ADAPTER 90 CYL 3/4 M-M BSP
20	33017808	1	ELBOW
21		1	MOTOR DRIVE (ITEM 8 SEE PAGE 35)
22	33017002	2	FITTING PIPE
23	33021256	1	STEERING CYLINDER
*	33011774	1	GASKET CYLINDER KIT
24	33010508	1	PORT, HYDRAULIC TEST 1/4"
*	33020764	1	GASKET HYDRAULIC PUMP KIT
25B	145 8867 000	1	CAP REDUCTION 3/4-1/2 MF
25C	33022396	1	ADAPTER 90 CYL 3/4 M-F BSP
26	33022090	1	WRENCH 14
27	33020812	2	SPACER
A:	33021257 - SEE PAGE 35 ITEM 10A AND SPEC		
B:	33016362 / 145 8867 000 - VALID FOR MACHINE CODE 13300107 BEFORE S.N. 3810123500027		
C:	33022395 / 33022396 - VALID FOR MACHINE CODE 13300107 STARTING S.N. 3810123500027		

HYDRAULIC PLANT - DRIVE MOTOR SCHEME

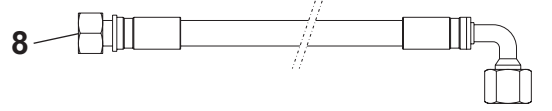
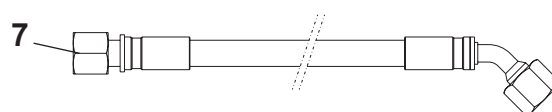
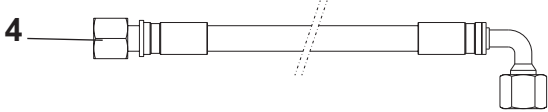
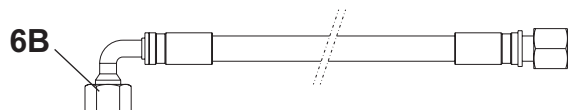
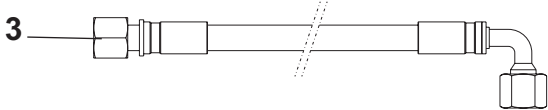
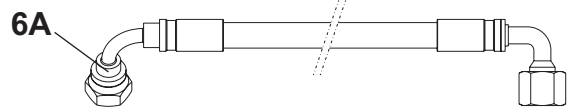
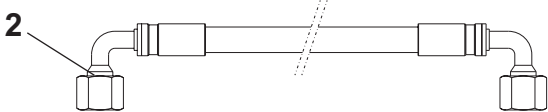
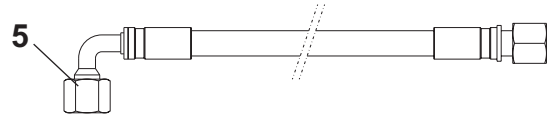
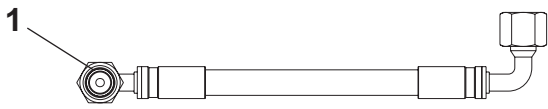
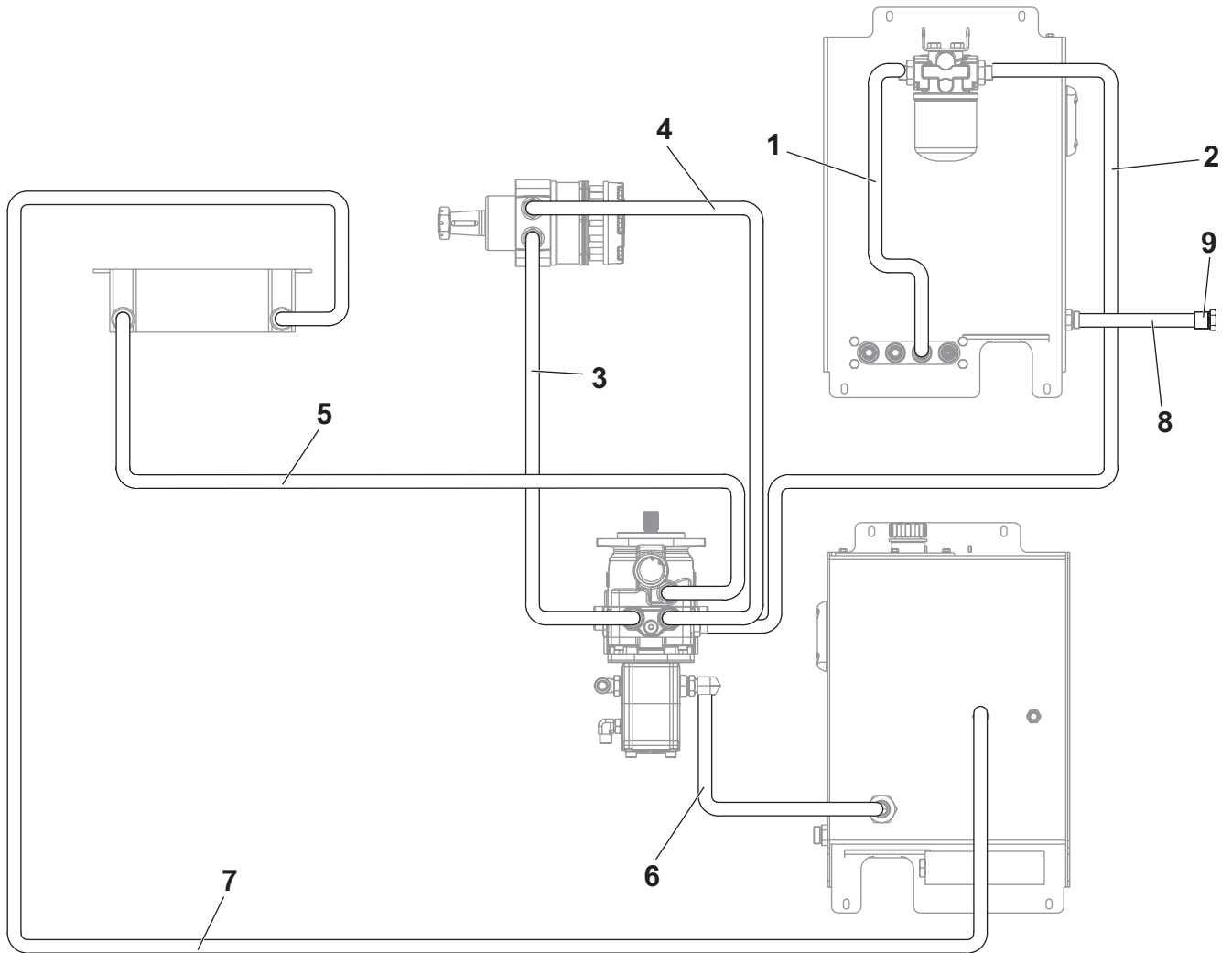

HYDRAULIC PLANT - DRIVE MOTOR SCHEME

ITEM	REF. NO.	QTY	DESCRIPTION
1	33017649	1	HOSE HYDRAULIC 1/2 L= 450
2	33018632	1	HOSE HYDRAULIC 1/2 L=1500
3	33017641	1	HOSE HYDRAULIC 1/2 L=1470
4	33017630	1	HOSE HYDRAULIC 1/2 L=1470
5	33019639	1	HOSE HYDRAULIC 1/2 L=1120
6A	33017651	1	HOSE HYDRAULIC 3/4 L= 900
6B	33022399	1	HOSE HYDRAULIC R1AT 3/4 L 840
7	33019640	1	HOSE HYDRAULIC 1/2 L=1115
8	33017620	1	HOSE HYDRAULIC 1/2 L 660
9	33011456	1	CAP MALE 1/2
A:	33017651 - VALID FOR MACHINE CODE 13300107 BEFORE S.N. 3810123500027		
B:	33022399 - VALID FOR MACHINE CODE 13300107 STARTING S.N. 3810123500027		

HYDRAULIC PLANT - STEERING SCHEME

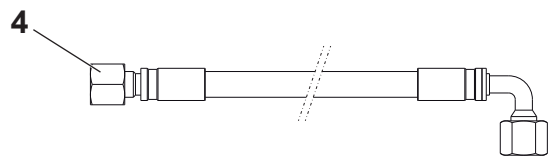
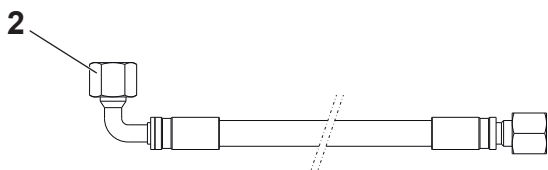
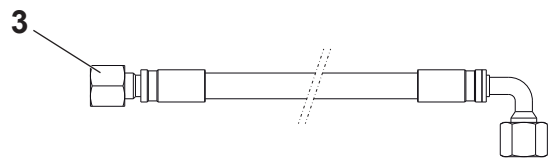
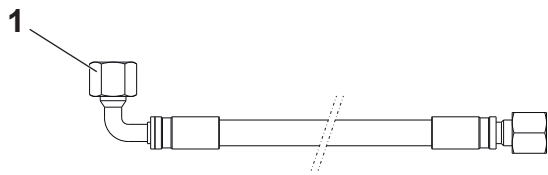
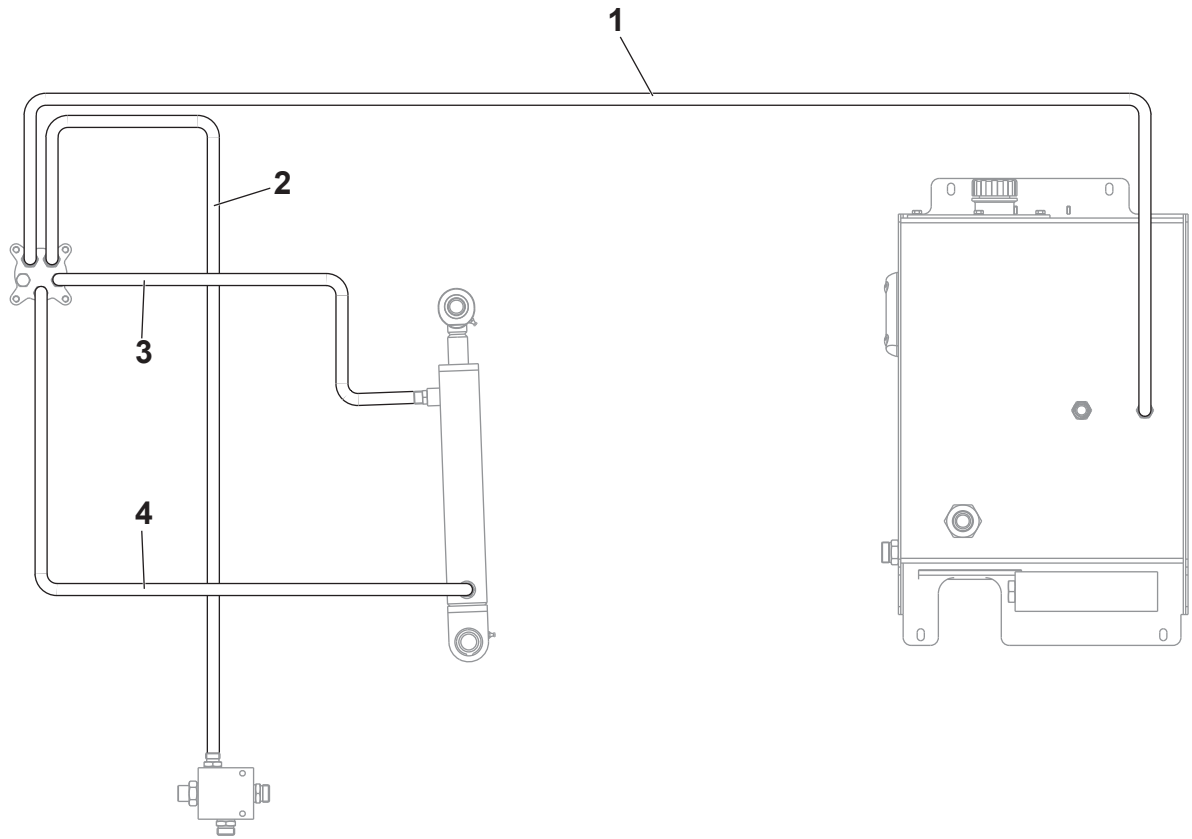

HYDRAULIC PLANT - STEERING SCHEME

ITEM	REF. NO.	QTY	DESCRIPTION
1	33020136	1	HOSE HYDRAULIC 3/8 L 1000
2	33020137	1	HOSE HYDRAULIC 3/8 L 1380
3	33017622	1	HOSE HYDRAULIC 1/4 L=1320
4	33017625	1	HOSE HYDRAULIC 1/4 L=1000

HYDRAULIC PLANT - FLAP AND HOPPER SCHEME

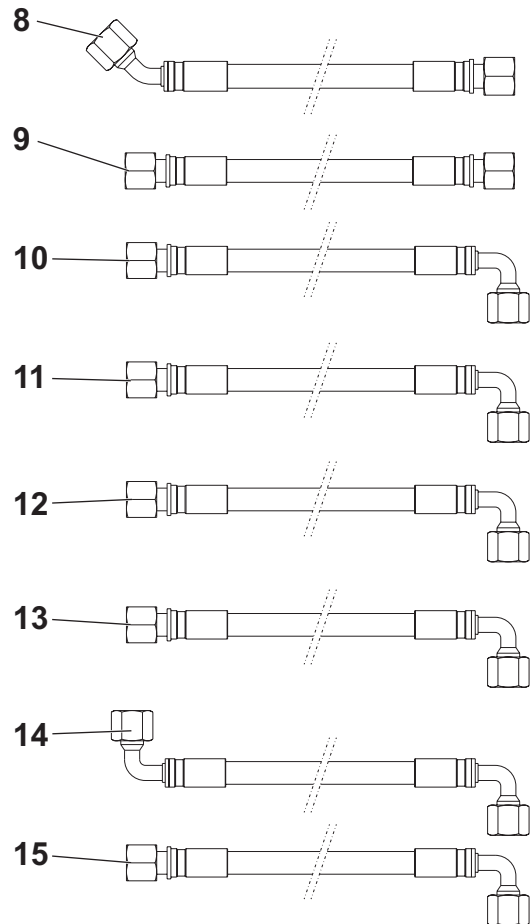
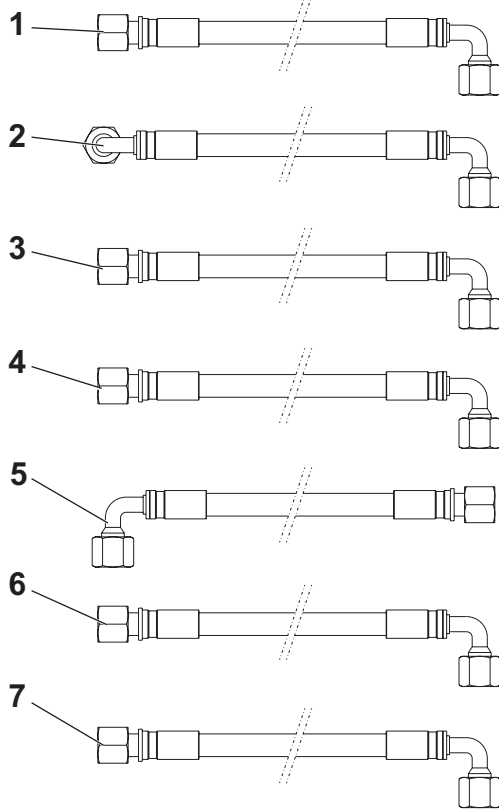
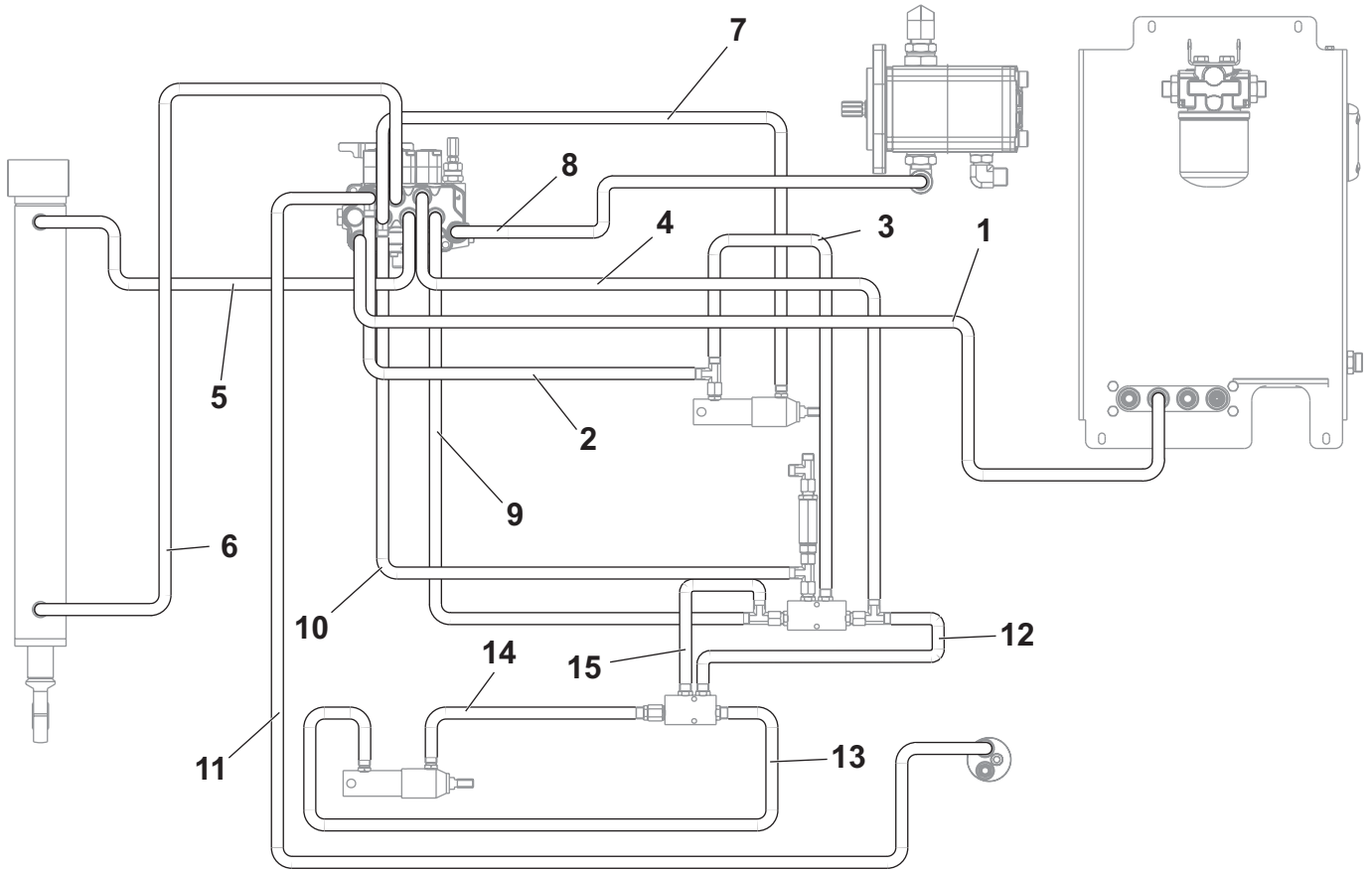

HYDRAULIC PLANT - FLAP AND HOPPER SCHEME

ITEM	REF. NO.	QTY	DESCRIPTION
1	33017650	1	HOSE HYDRAULIC 1/2 L=1050
2	33017635	1	HOSE HYDRAULIC 1/4 L=1580
3	33017634	1	HOSE HYDRAULIC 1/4 L= 500
4	33017628	1	HOSE HYDRAULIC 1/4 L=1560
5	33017652	1	HOSE HYDRAULIC 1/4 L= 650
6	33017627	1	HOSE HYDRAULIC 1/4 L= 460
7	33017632	1	HOSE HYDRAULIC 1/4 L=1650
8	33020284	1	HOSE HYDRAULIC 1/2 L 340
9	33017653	1	HOSE HYDRAULIC 1/4 L=1340
10	33017633	1	HOSE HYDRAULIC 1/4 L=1390
11	33017655	1	HOSE HYDRAULIC 3/8 L=1350
12	33019714	1	HOSE HYDRAULIC 1/4 L= 450
13	33017638	1	HOSE HYDRAULIC 1/4 L=3020
14	33017647	1	HOSE HYDRAULIC 1/4 L=2320
15	33019713	1	HOSE HYDRAULIC 1/4 L= 450

HYDRAULIC PLANT - SIDE BROOM SCHEME

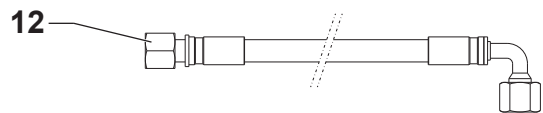
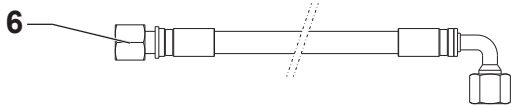
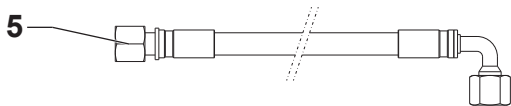
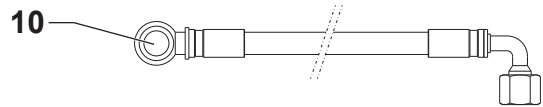
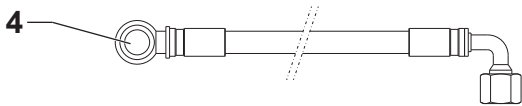
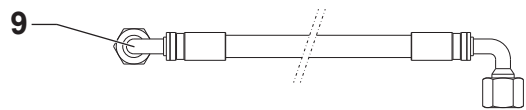
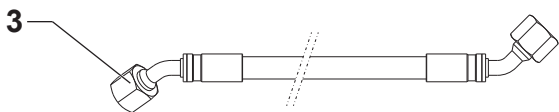
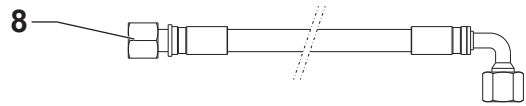
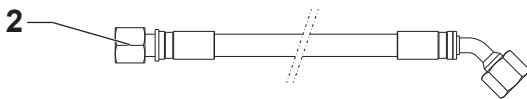
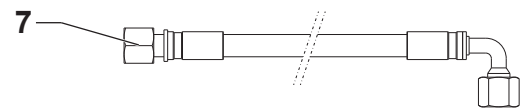
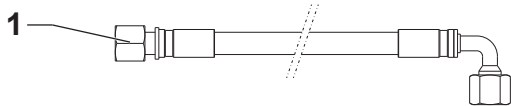
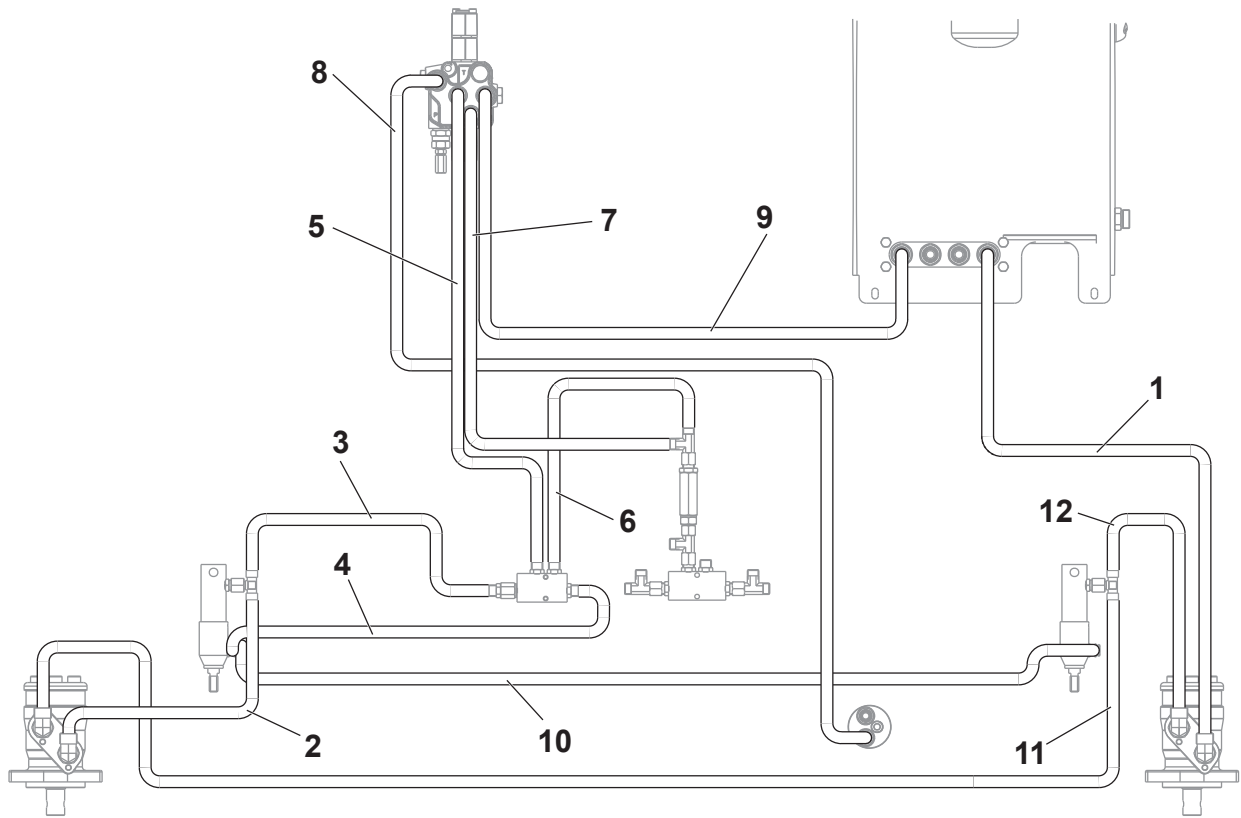

HYDRAULIC PLANT - SIDE BROOM SCHEME

ITEM	REF. NO.	QTY	DESCRIPTION
1	33017645	1	HOSE HYDRAULIC 1/2 L=2170
2	33017640	1	HOSE HYDRAULIC 3/8 L= 625
3	33017654	1	HOSE HYDRAULIC 1/4 L=2600
4	33017643	1	HOSE HYDRAULIC 1/4 L=3400
5	33017646	1	HOSE HYDRAULIC 1/4 L=1460
6	33017637	1	HOSE HYDRAULIC 1/4 L= 330
7	33017639	1	HOSE HYDRAULIC 1/4 L=1620
8	33017631	1	HOSE HYDRAULIC 3/8 L=1520
9	33017648	1	HOSE HYDRAULIC 1/2 L=1050
10	33017644	1	HOSE HYDRAULIC 1/4 L=2500
11	33017629	1	HOSE HYDRAULIC 3/8 L=2900
12	33017642	1	HOSE HYDRAULIC 3/8 L= 660

ACCESSORIES

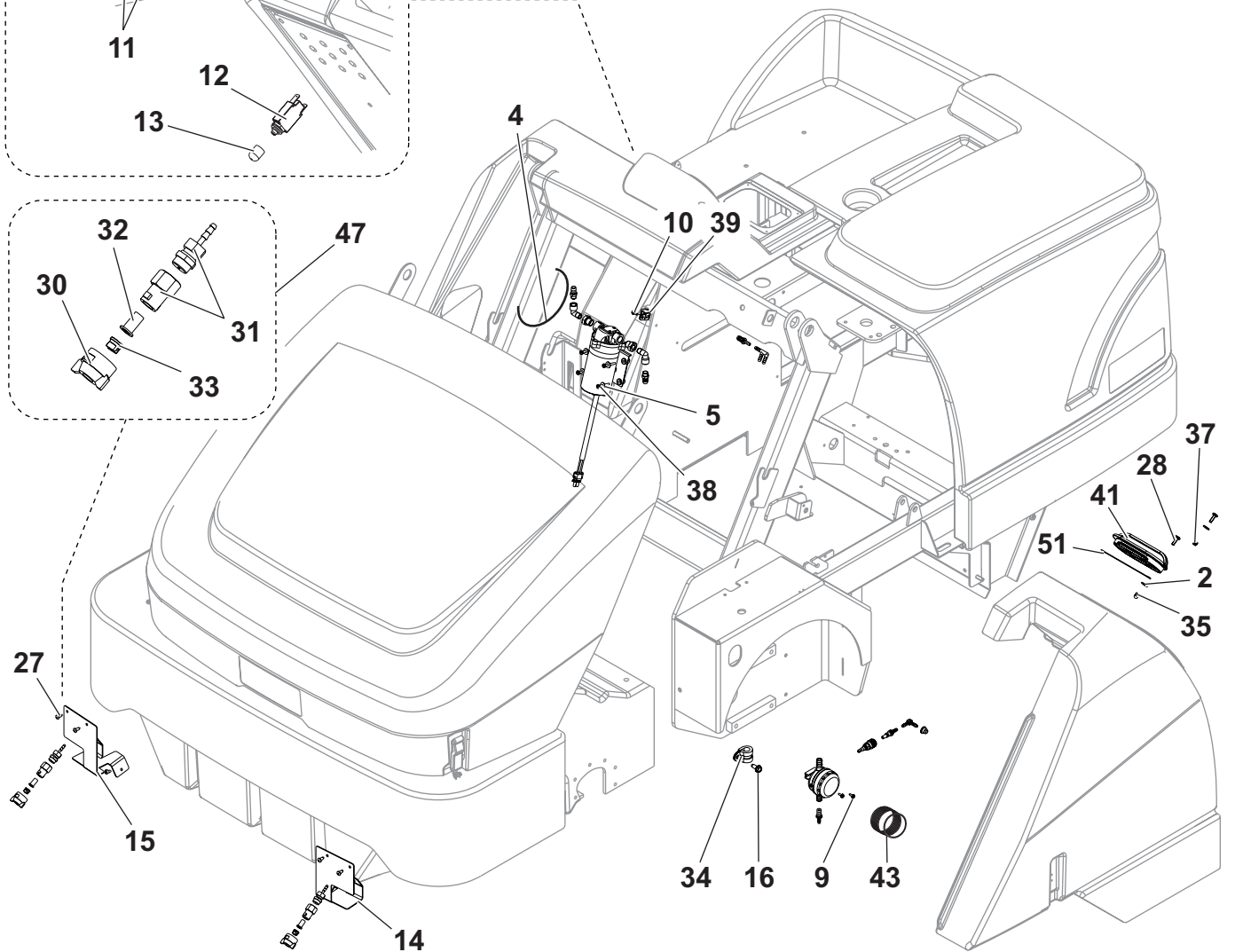
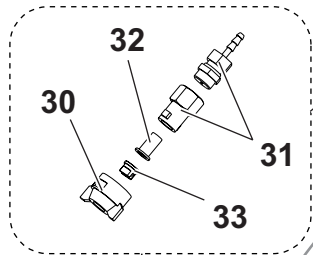
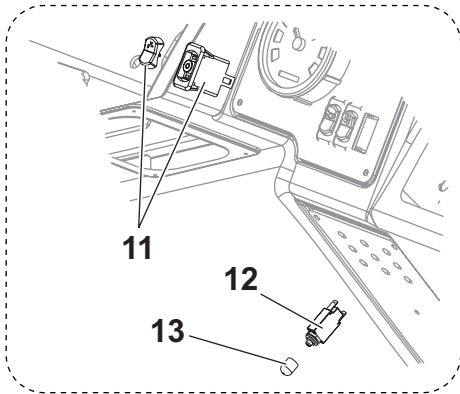
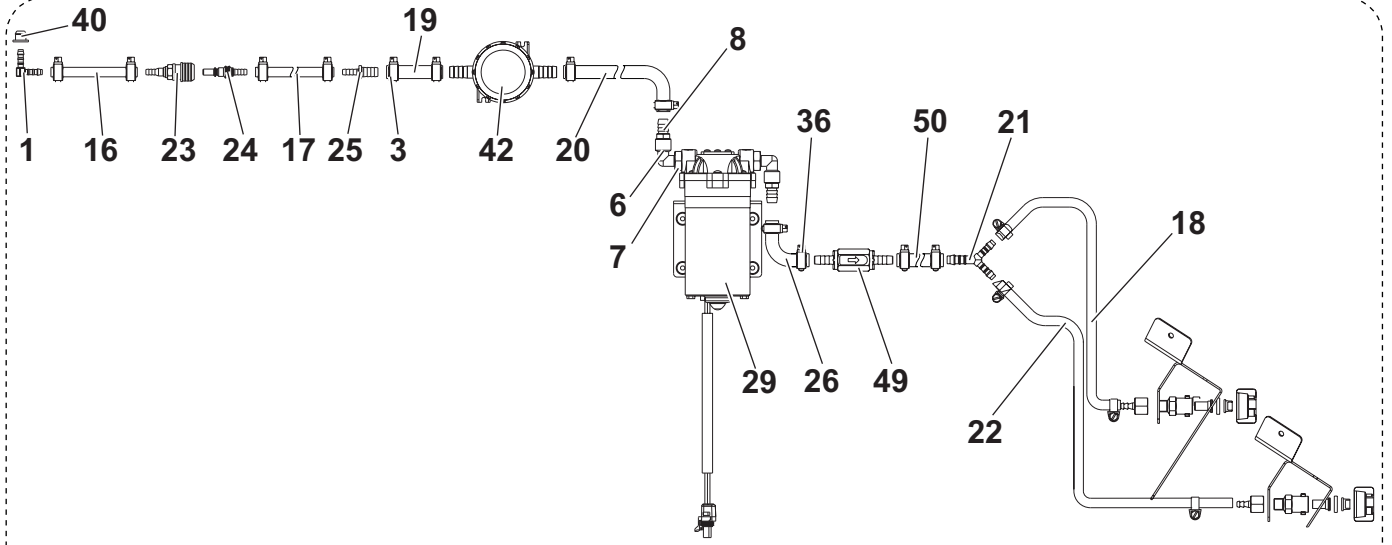

ACCESSORIES

	ITEM	REF. NO.	QTY	DESCRIPTION
	1	33020824	1	ELBOW 90. D. 8 NYLON
	2		2	WASHER 6X18X1.5 UNI6593
	3		8	CLAMP
	4		6	CLAMP 9X350
	5		4	WASHER 5X15 UNI6593
	6	33011224	2	FITTING1/4
	7	33011494	2	REDUCTION GEAR MF 3/8 1
	8	33011522	2	RUBBER SEAL HOLDER 1/4 D
	9		2	SCREW THREAD ROLLING
	10		1	SCREW THREAD ROLLING
	11	33019325	1	SWITCH WATER FLUSHING KIT (SW6)
	12	33019709	1	BREAKER CIRCUIT 2A (F3)
	13	33017386	1	BOOT CIRCUIT BREKER
	14	33017927	1	BRACKET LEFT SIDE
	15	33017928	1	BRACKET RIGHT SIDE
	16		2	SCREW THREAD ROLLING
	17		1	HOSE CRISTAL 6X11 L 480
	18		1	HOSE CRISTAL 6X11 L 2020
	19		1	HOSE D.10 L 65
	20		1	HOSE D.10 L 1400
	21	33020820	1	ELBOW Y D.6-8-6
	22		1	HOSE CRISTAL 6X11 L 2740
	23	1465915000	1	CONNECTOR
	24	1465916000	1	CONNECTOR
#	25	9100000453	1	FITTING STRAIGHT REDUCER
	26		1	HOSE D.10 L 60
	27		6	SCREW 6X20
	28		2	SCREW M6X20
	29	33019726	1	PUMP WATER KIT (M3)
	30	33020817	2	RING NUT QUICK COUPLING
	31	33020865	2	ADAPTER SPRAY KIT
	32	33022026	2	FILTER NOZZLE SPRAY
	33	33020816	2	NOZZLE SPRAY
	33	33022072	2	NOZZLE SPRAY 0.53
	34		1	COLLAR D.10
	35		1	NUT HEX M6 UNI5721
	36	145 8582 000	8	CLAMP HOSE
	37		1	NUT SELF LOCKING M6 SS
	38		4	SCREW 4.5X40
	39		1	CLAMP HOSE D.18
	40	909 6089 000	1	CHOCK D.18
	41	9097385000	1	CAP SOLUTION TANK
#	42	9100000362	1	FILTER WATER
#	43	9099481000	1	NET WATER FILTER REINFORCED
	[44]	33019249	1	HARNESS MISTING SYSTEM
	[45]*	33019377	1	PRE MISTING SYSTEM 48V KIT
		33019375	1	INSTRUCTIONS ASSEMBLY
	47	33019324	2	NOZZLE SPRAY KIT (ITEM 30-31-32-33)
	[48]	33019326	1	HOSES/FITTINGS MISTING SYSTEM KIT (ITEM 21-23-24-25-6-7-8-3-4-39-40-1-17-18-19-20-26-22)
	49A	33021303	1	KIT CHECK VALVE
	50A		1	HOSE D.10 L 780
	50A	33022092	1	HOSE POLYESTER YARN REINF. D.10
	51	9097485000	1	CABLE OPENING CAP
	A:	SEE TSB IT 2012-083		

ACCESSORIES

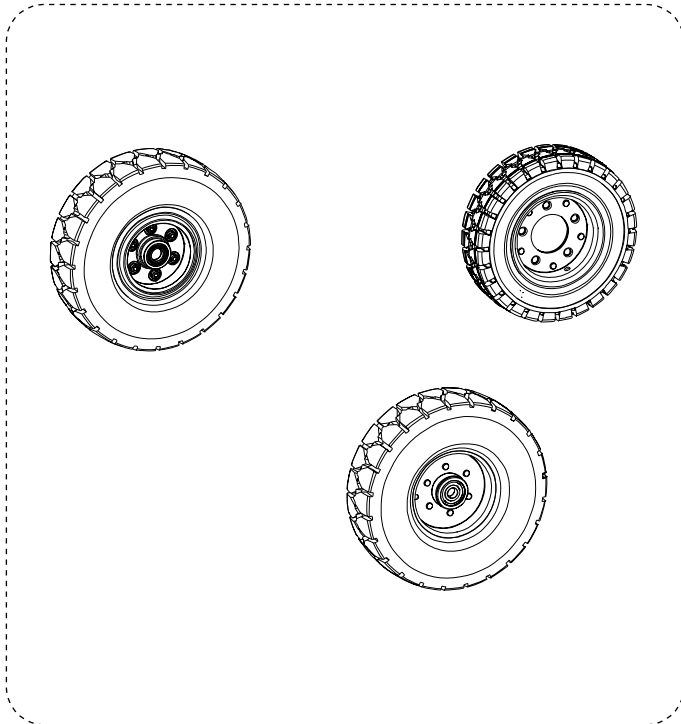

1

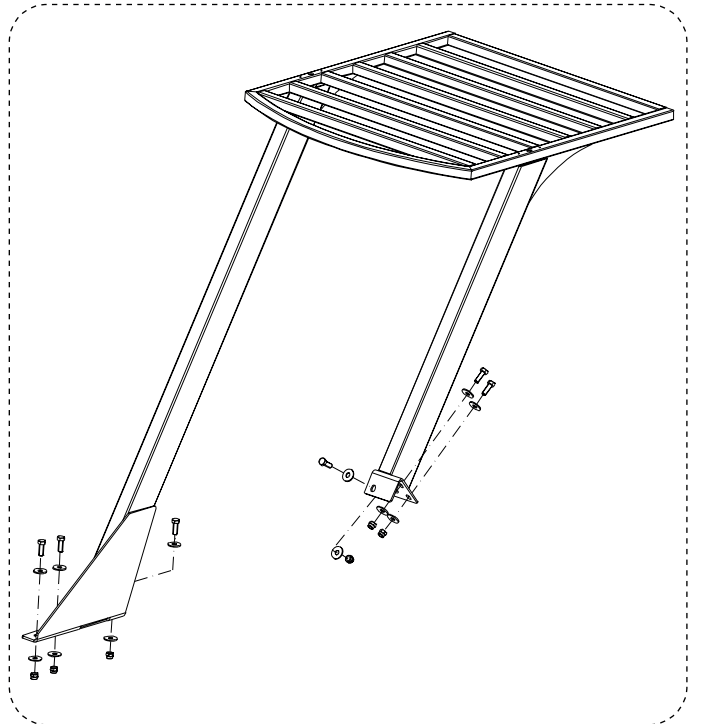

2

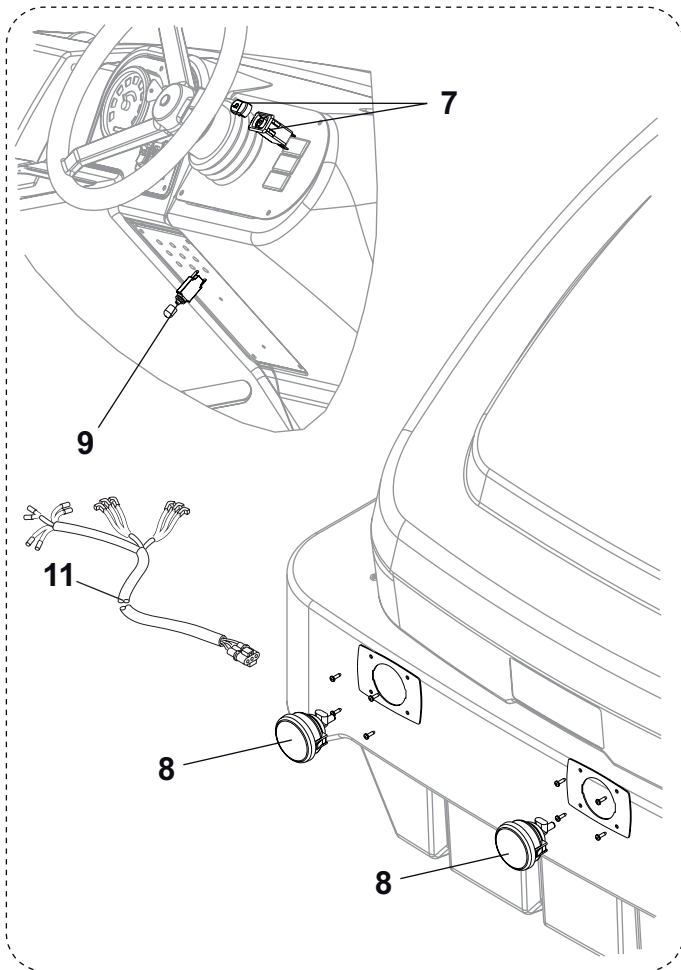

5

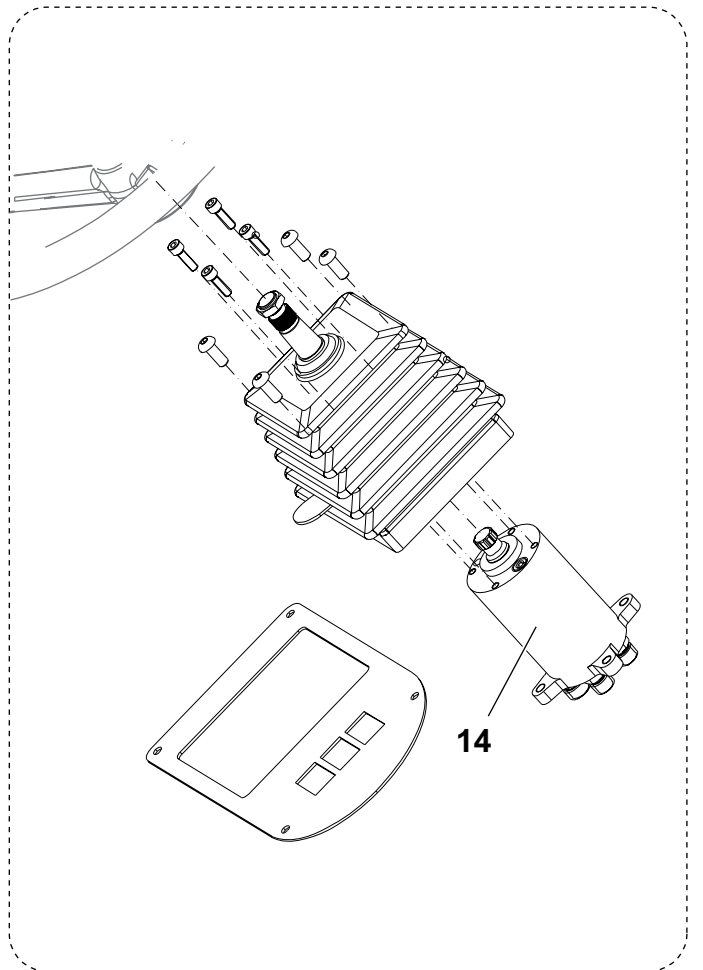

12

ACCESSORIES

	ITEM	REF. NO.	QTY	DESCRIPTION
	1*	33019172	1	WHEEL SOLID NON MARKING KIT
			1	WHEEL 4.00-8 NO MARK VERS
			2	WHEEL 5.00-8 NO MARK VERS
	2*	33019171	1	OVER HEAD GUARD KIT
		33020629	1	INSTRUCTIONS ASSEMBLY
			6	NUT SELF L. M12 UNI7473
			6	SCREW M12X35 UNI5739
			12	WASHER 12X36X3 UNI6593
			1	OVER HEAD GUARD
	[3]*	56508663	1	MIRROR KIT
		56040968	1	INSTRUCTIONS ASSEMBLY
	5*	33019560	1	FRONT LIGHT 48V KIT
		33019201	1	INSTRUCTIONS ASSEMBLY
	7	33019736	1	SWITCH FRONT LIGHT
	8	33019229	2	HEADLIGHT 24V (L1/L2)
	9	33017361	1	BREAKER CIRCUIT 10A (F6)
	[10]	33019734	2	LAMP
	11	33019220	1	HARNESS FRONT HEADLIGHT
			2	PLATE FOR FRONT LIGHT
			8	SCREW 4.8X19 UNI6954
	12*	33019174	1	TILT STEERING KIT
		33019157	1	INSTRUCTIONS ASSEMBLY
	14	33022286	1	STEERING UNIT KIT
	*	33022033	1	GASKET STEERING UNIT
			4	SCREW M6X20 UNI5931
			1	STEERING TILT
			1	STEERING WHEEL
			1	COVER PLATE TILT STEERING
#	[15]*	56507039	1	AMBER STROBE LIGHT FOR USE WITH OHG
#		56040899	1	ASSEMBLY INSTRUCTION
#	[16]	33022486	1	HARNESS BEACON FOR OHG KIT
#		33022485	1	ASSEMBLY INSTRUCTION
#	[17]*	56507038	1	FLASHING BEACON
#		56040898	1	INSTALLATION INSTRUCTIONS
#	[18]	33022681	1	HARDWARE BEACON KIT

ACCESSORIES

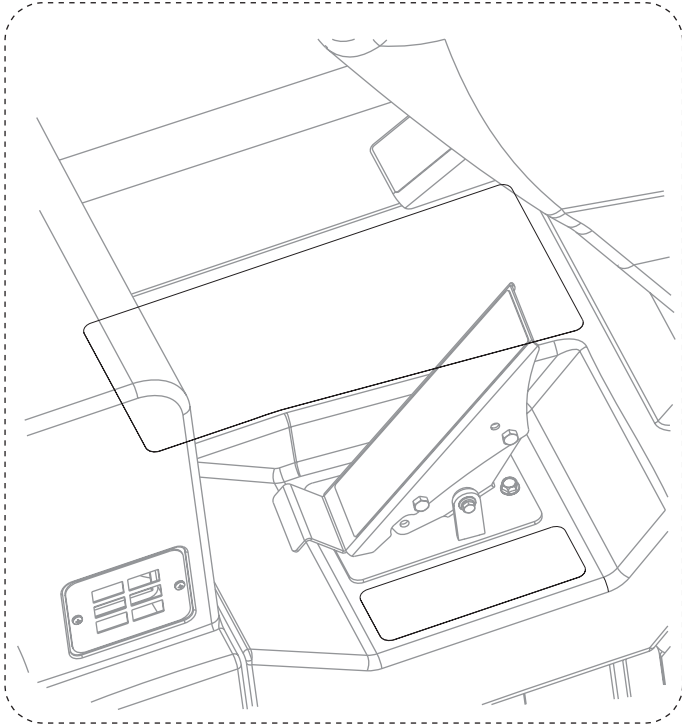

1

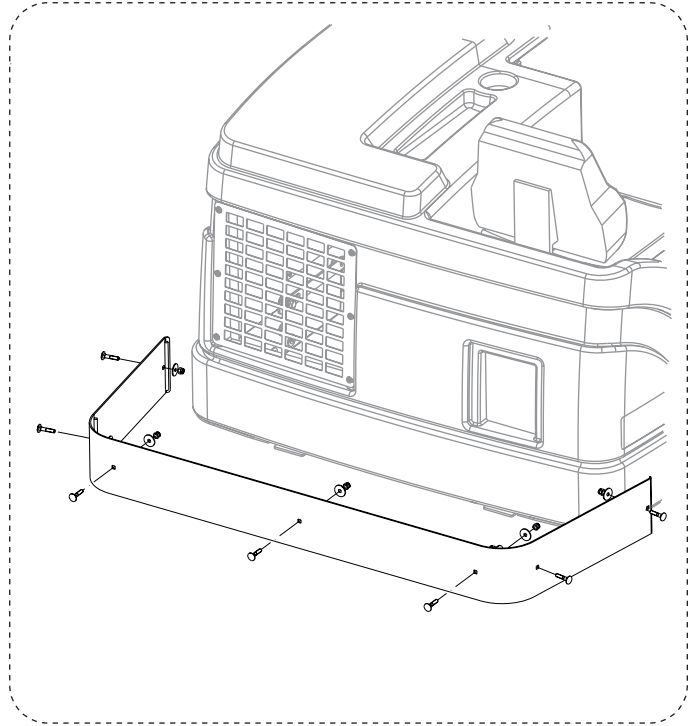

3

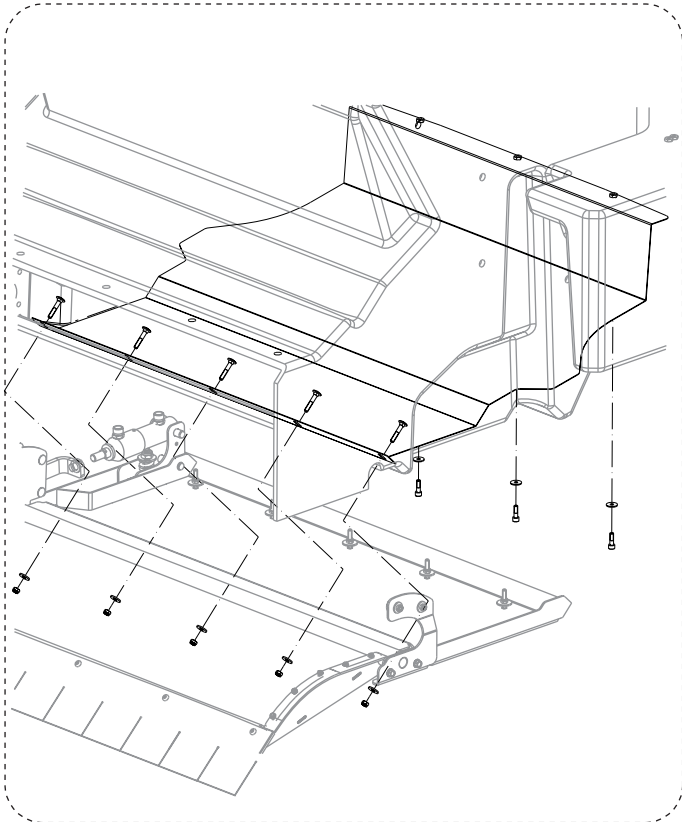

5

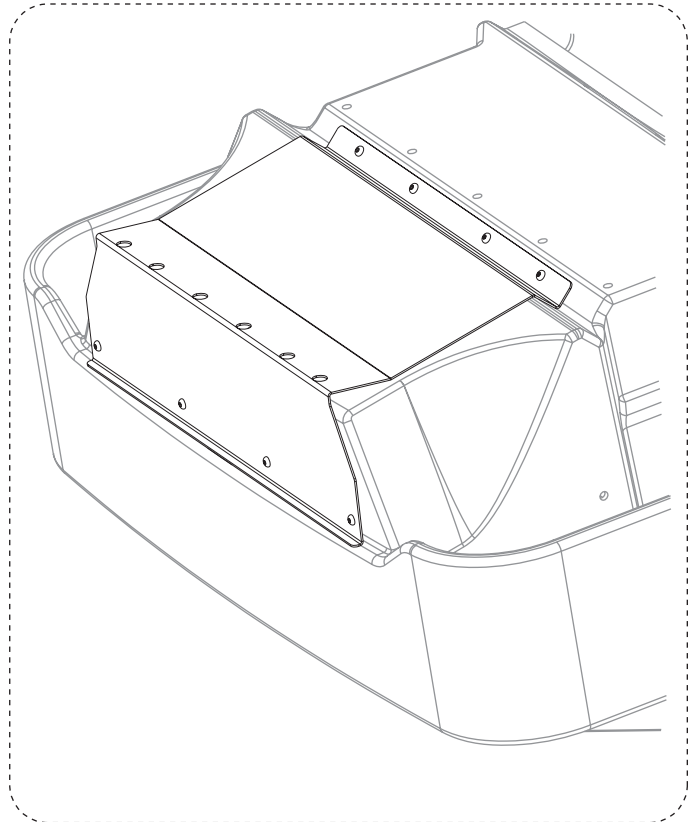

7

ACCESSORIES

	ITEM	REF. NO.	QTY	DESCRIPTION
	1*	33019570	1	MAT FLOOR KIT
		33019195	1	INSTRUCTIONS ASSEMBLY
	3*	33019572	1	GUARD REAR BUMPER KIT
		33019205	1	INSTRUCTIONS ASSEMBLY
	5*	33019573	1	METAL LINER HOPPER KIT
		33019207	1	INSTRUCTIONS ASSEMBLY
	7*	33021392	1	FRONT PROTECTION KIT
		33021393	1	INSTRUCTIONS ASSEMBLY

ACCESSORIES

1

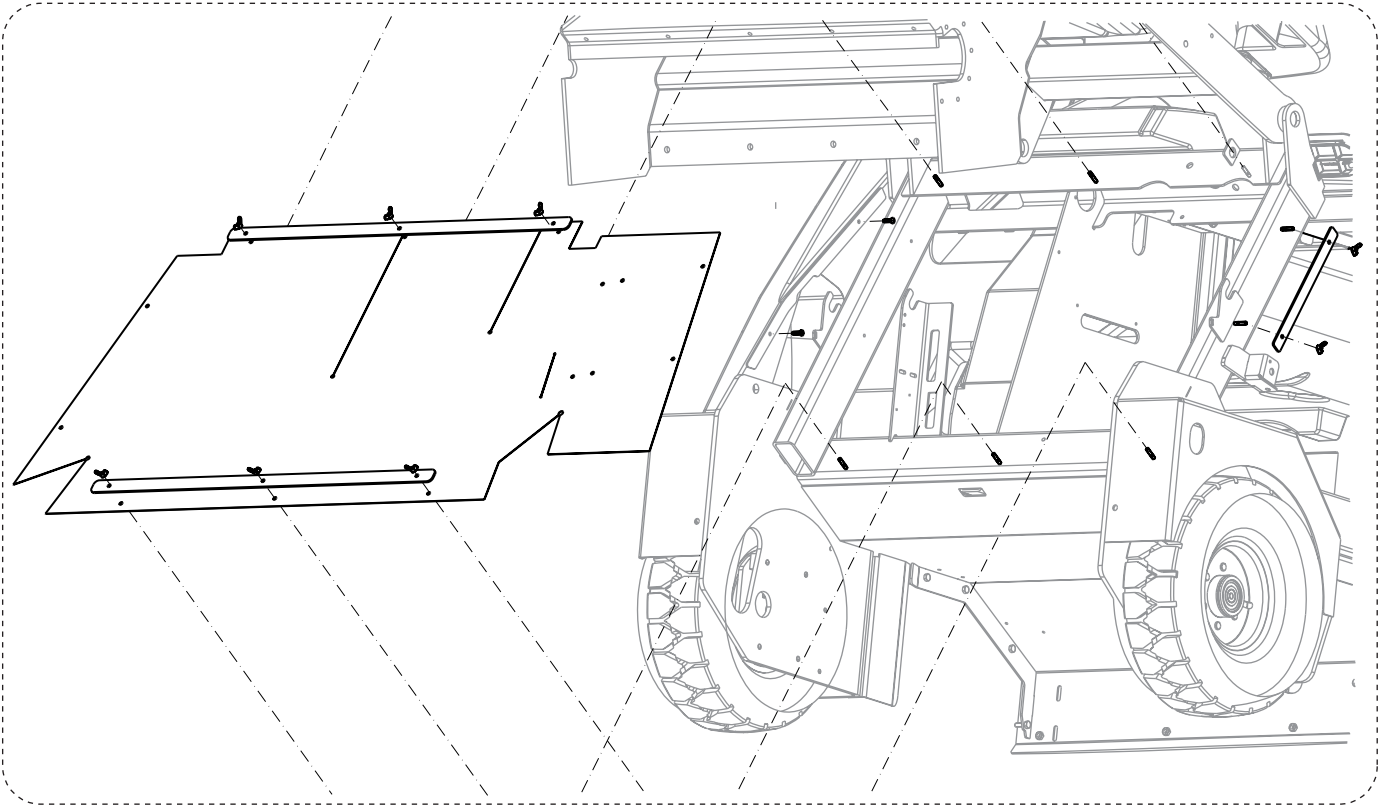

2

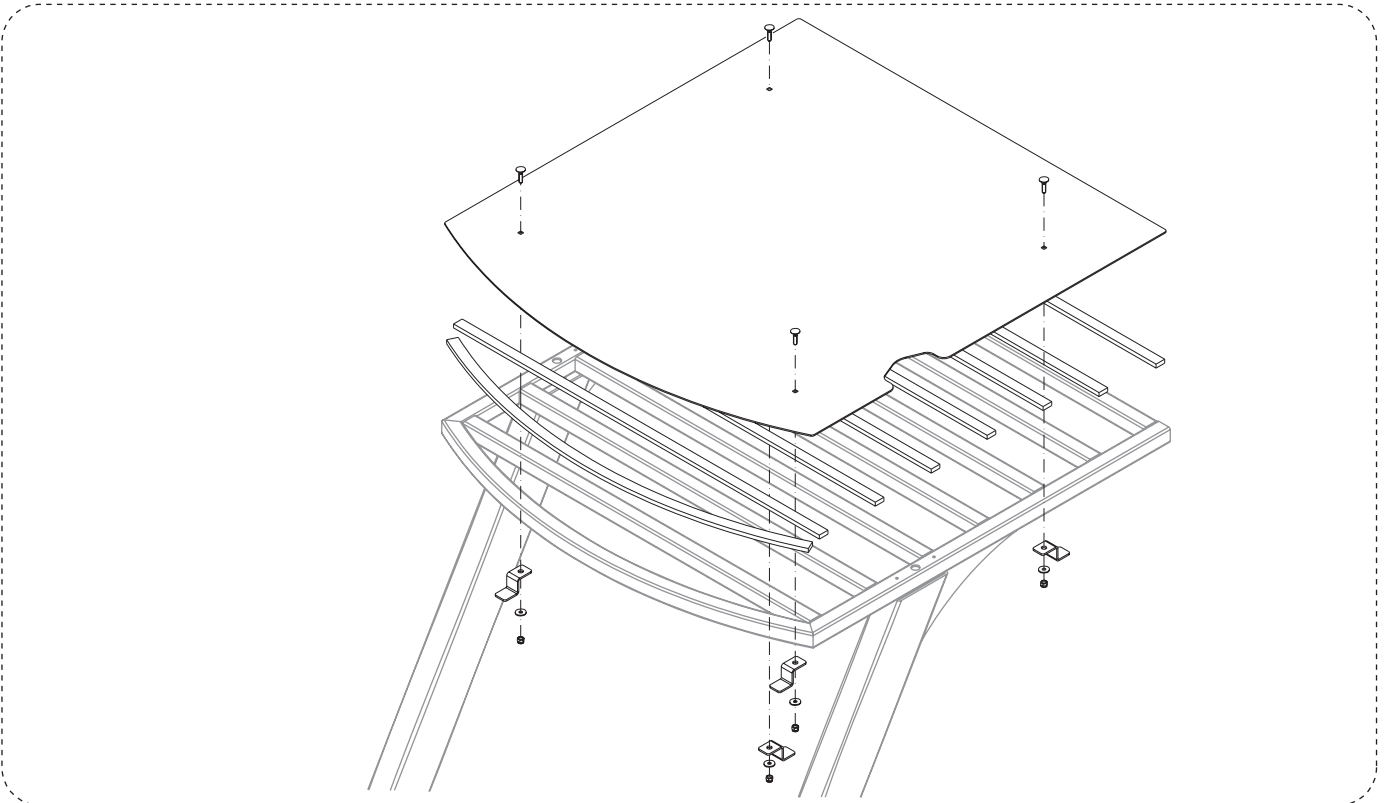

ACCESSORIES

	ITEM	REF. NO.	QTY	DESCRIPTION
	1	33020372	1	HOPPER DUST FLAP KIT
		33020373	1	INSTRUCTIONS ASSEMBLY
	2*	33020052	1	CANOPY KIT
		33020051	1	INSTRUCTIONS ASSEMBLY

ACCESSORIES

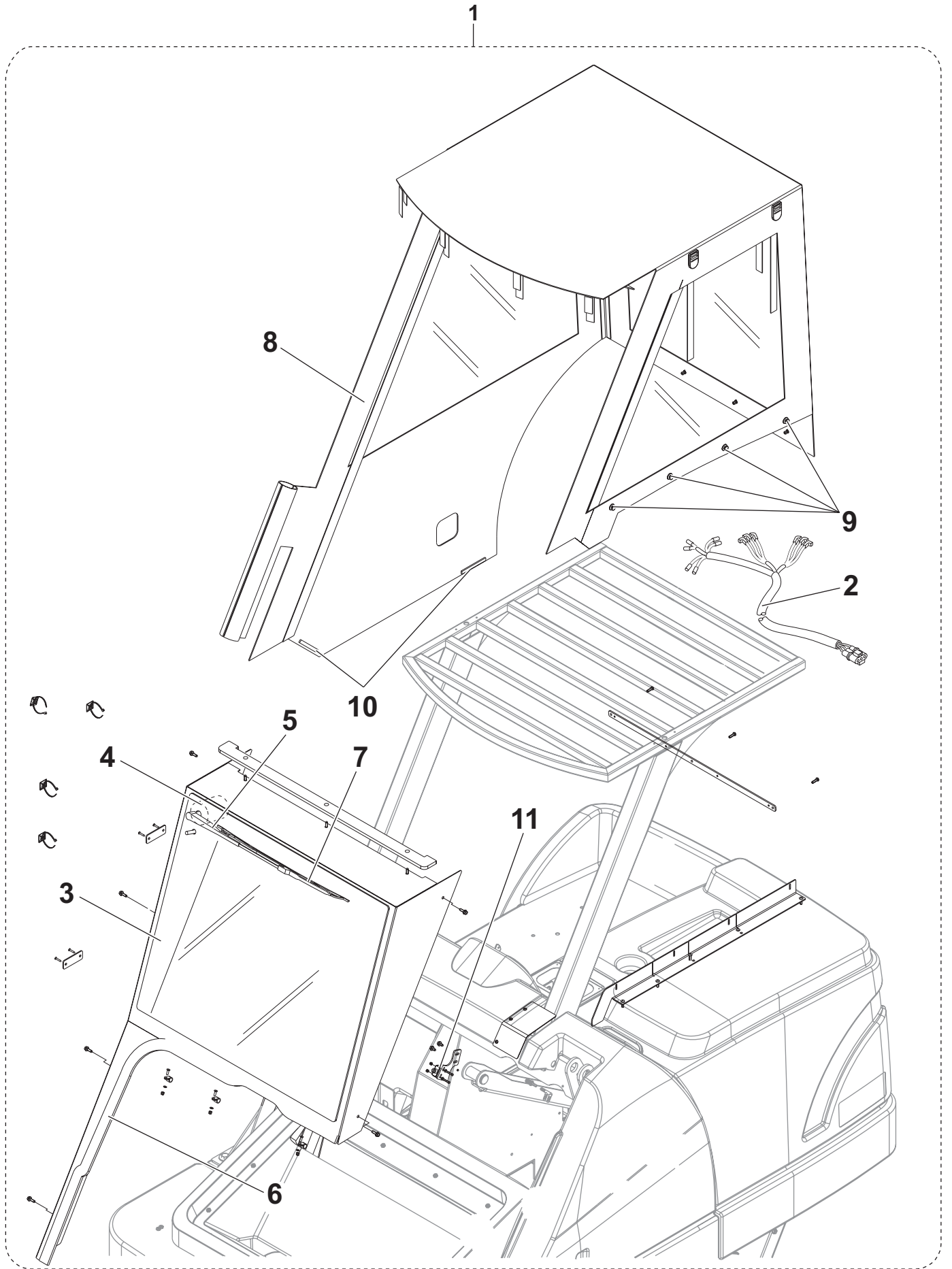

ACCESSORIES

	ITEM	REF. NO.	QTY	DESCRIPTION
	1*	33020002	1	CANOPY KIT
		33020001	1	INSTRUCTIONS ASSEMBLY
	2	33020456	1	HARNESS WINDSCREEN WIPER
	3	33020288	1	WINDSCREEN
	4	33020457	1	MOTOR WINDSCREEN WIPER
	5	33020571	1	ARM WINDSCREEN WIPER
	6	33020623	1	GASKET
	7	33020460	1	WINDSCREEN WIPER
	8	33020292	1	CABIN SOFT
	9	33020461	8	COUPLING QUICK LOCK
	10	33020611	2	MAGNET FIXING CABIN
	11	33020459	1	MICROSWITCH 16A 250V

WIRING DIAGRAM - PAGE 2

PAGE 1

PAGE 3

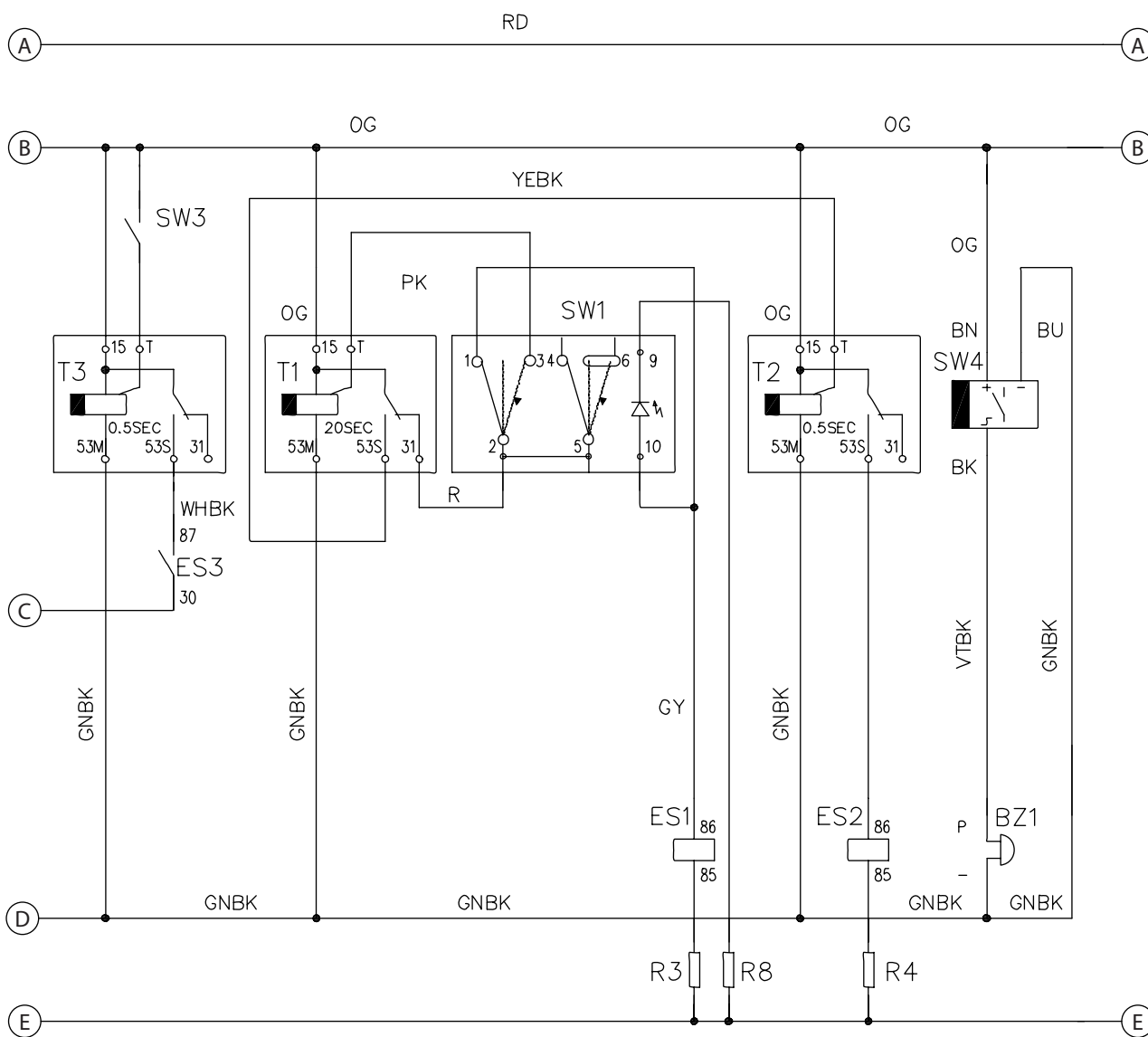

WIRING DIAGRAM - PAGE 3

PAGE 2
←

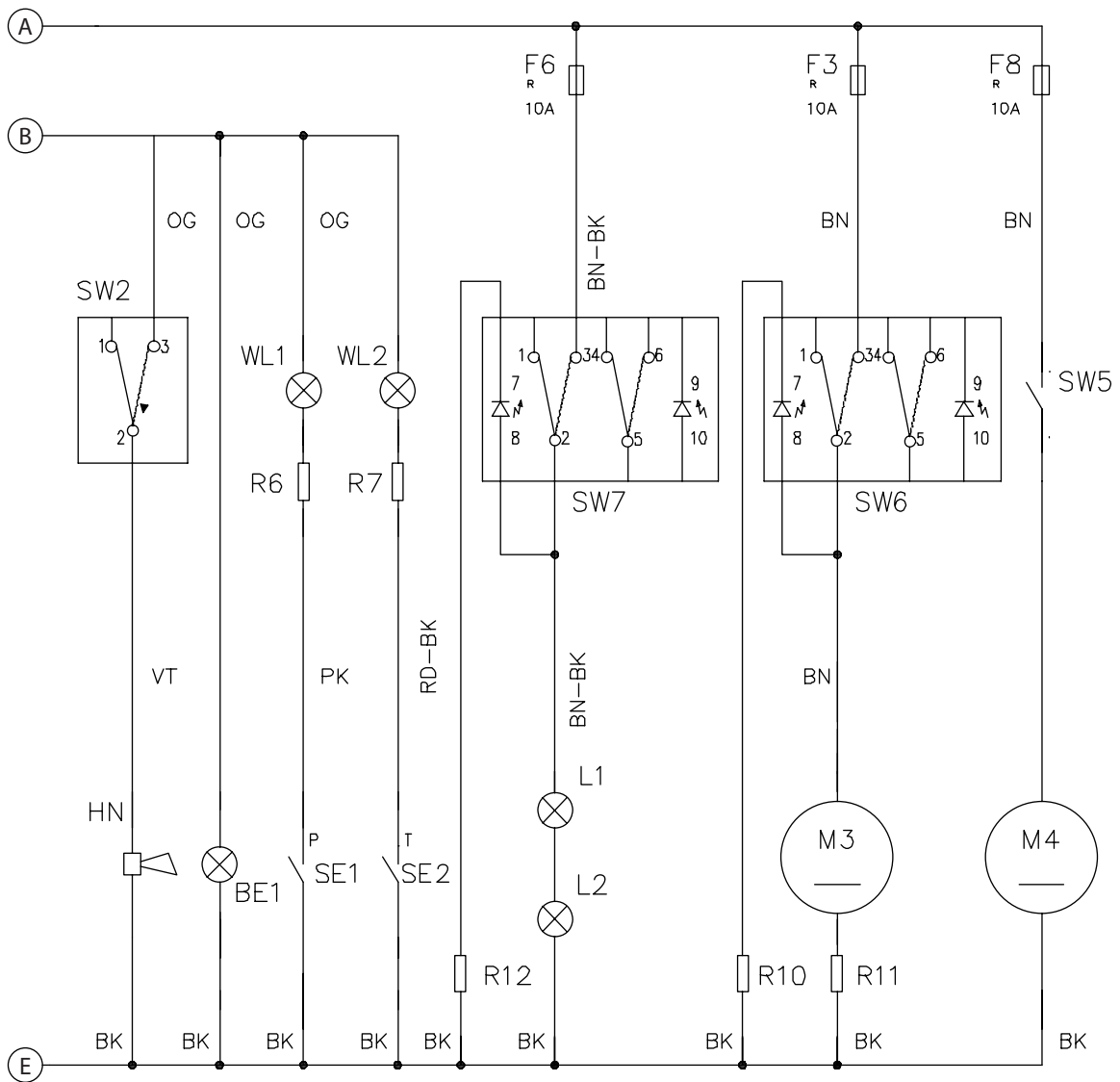

WIRING DIAGRAM - PAGE 4

KEY	REF. NO.	DESCRIPTION
BAT	80562010	BATTERY 48V (OPTIONAL)
BE1	56305223	PIVOTING LIGHT
BZ1	33022643	REVERSE GEAR BUZZER
C1	33019166	BATTERY CONNECTOR
D1	NA	DIODE
ES0	33017449	PRIMARY HYDRAULIC PUMP CONTACTOR
ES1	909 6622 000	VACUUM MOTOR RELAY
ES2	909 6622 000	FILTER SHAKER RELAY
ES3	146 1646 000	START RELAY
F0	33008583	PRIMARY HYDRAULIC PUMP FUSE (250 A)
F1	33017361	VACUUM SYSTEM CIRCUIT BREAKER
F2	33020282	FILTER SHAKER CIRCUIT BREAKER
F3	33019709	WATER PUMP CIRCUIT BREAKER (OPTIONAL)
F4	33017360	IGNITION KEY CIRCUIT BREAKER
F5	33017361	MOTOR ACCESSORY CIRCUIT BREAKER
F6	33017361	WORK LIGHTS CIRCUIT BREAKER (OPTIONAL)
F8	33017361	CAB FAN CIRCUIT BREAKER (OPTIONAL)
F10	909 5101 000	AUXILIARY FUSE (30 A)
HN	33009017	HORN
K1	33020442	IGNITION SWITCH
L1/2	33019229	WORK LIGHTS (OPTIONAL)
M1	33015700	VACUUM SYSTEM MOTOR
M2	33017232	FILTER SHAKER MOTOR
M3	33019726	WATER PUMP (OPTIONAL)
M4	TBD	FAN CAB (OPTIONAL)
M5	33020222	OIL COOLER FAN
M6	33023036	MP COOLER FAN
MP	33022549	PRIMARY ELECTRIC MOTOR
R1	NA	T1, T2, BZ1 RESISTOR
R2	NA	T1, T2, BZ1 RESISTOR
R3	NA	ES1 RESISTOR
R4	NA	ES2 RESISTOR
R5	NA	ES3 RESISTOR
R6	NA	WL1 RESISTOR (OPTIONAL.)
R7	NA	WL2 RESISTOR (OPTIONAL)
R8	NA	SW1 RESISTOR
R9	NA	M5 RESISTOR
R10	NA	SW6 RESISTOR
R11	NA	M3 RESISTOR (OPTIONAL)
STR	33017221	GAUGE
SE1	TBD	PLUGGED FILTER SENSOR (OPTIONAL)
SE2	TBD	HOPPER TEMPERATURE SENSOR (OPTIONAL)
SW1	33018843	VACUUM SYSTEM/FILTER SHAKER SWITCH
SW2	33018844	HORN SWITCH
SW3	NA	SEAT SWITCH
SW4	33018521	REVERSE GEAR PROXIMITY SENSOR
SW5	TBD	FAN SWITCH
SW6	33019325	WATER PUMP SWITCH (OPTIONAL)
SW7	TBD	WORK LIGHTS SWITCH (OPTIONAL)
T1	33017359	PRIMARY FILTER SHAKER TIMER
T2	33017385	SECONDARY FILTER SHAKER TIMER
T3	33019197	SEAT SWITCH TIMER
WL1	TBD	PLUGGED FILTER LED (OPTIONAL)
WL2	TBD	HOPPER TEMPERATURE LED (OPTIONAL)

KEY	COLOUR
BK	BLACK
BU	LIGHT BLUE
BN	BROWN
GN	GREEN
GY	GREY
OG	ORANGE

KEY	COLOUR
PK	PINK
RD	RED
VT	VIOLET
WH	WHITE
YE	YELLOW

HYDRAULIC DIAGRAM

ITEM	REF. NO.	DESCRIPTION
1	33018809	OIL TANK
2	33010199	OIL FILTER
3	33022111	DRIVE SYSTEM PUMP
4	33020224	ACCESSORY PUMP
5	33019737	DRIVE SYSTEM MOTOR
6	33022292	POWER STEERING
7	33018808	STEERING CYLINDER
8	33022413	OIL COOLER
9	33018812	MANIFOLD 3 LEVERS
10	33018811	HOPPER LIFTING CYLINDER
11	33018802	SKIRT CYLINDER
12	33018872	MAIN BROOM MOTOR
13	33021765	MAIN BROOM CYLINDER
14	33018815	MANIFOLD 1 LEVER
15	33018807	RIGHT SIDE BROOM MOTOR
16	33021767	RIGHT SIDE BROOM CYLINDER
17	33018840	CHECK VALVE
18	33010481	ONE-WAY VALVE
19	33018816	DOUBLE CHECK VALVE
20	33017432	MANIFOLD BLOCK
21	33018807	LEFT SIDE BROOM MOTOR
22	33021766	LEFT SIDE BROOM CYLINDER
23	33017431	OIL FILTER

RECOMMENDED SPARE PARTS

	REF. NO.	QTY	DESCRIPTION	
	33003175	1	BEARING 32007	
	145 4691 000	1	BEARING	
	33017129	1	GASKET TRIM EDGE BULB	
	33017171	1	FLAP SIDE	
	33017172	1	FLAP SIDE	
	33017173	2	FOAM HOPPER SIDE	
	33017174	1	FLAP REAR BROOM	
	33018803	1	LATCH KIT	
	33017257	1	TRIM EDGE BULB L 900MM	
	33017126	1	SEAL HOPPER COVER L 2930	
	33015700	1	MOTOR VACUUM 48V (M1)	
	33016950	1	GASKET	
	8-24-04139-1	1	PANEL FILTER	
	33018634	1	GASKET FILTER ASSY L 2560	
	33017232	1	MOTOR FILTER SHAKER 48V (M2)	
	33021313	1	SIDE BROOM ATLANTIS PPL	
	33017255	1	BROOM SIDE PPL 259X550	
	33019102	1	PIN SIDE BROOM KIT	
	33010199	1	FILTER HYDRAULIC OIL	
	33011530	1	PLUG	
	33001307	1	GASKET	
	33018812	1	DISTRIBUTOR 3 ELEMENTS KIT	
	33018815	1	DISTRIBUTOR 1 ELEMENT KIT	
	33018816	1	VALVE PRIORITY KIT	
	33018817	1	CUTOFF VALVE DOUBLE KIT	
	33018840	2	CUTOFF VALVE KIT	
	33018258	1	FAN	
	33017199	1	SPRING	
	33017259	1	MAT PEDAL	
	33018841	1	FOOT PEDAL UPPER KIT	
	33018843	1	SWITCH SUCTION KIT (SW1)	
	33018844	1	SWITCH HORN KIT (SW2)	
	33017221	1	GAUGE 48V (STR)	
	33017375	1	DECAL GAUGE PANEL	
	33020442	1	SWITCH KEY	
	146 0073 00	1	KEY (1PC)	
	33017385	1	RELAY TIMER 0.5 SEC. (T2)	
	33017356	1	HARNESS RELAY BATTERY	
	33019197	1	RELAY TIMER 0.5 SEC. (T3)	
	33017360	1	BREAKER CIRCUIT 16A	
	33018858	1	BROOM MAIN SPIRAL PPL 0.5 WHITE NAVY/STEEL 0.36	
	33002106	1	SPRING MAIN BROOM	
	33018866	1	SUPPORT BEARING KIT	
	33018867	1	ROD SPRING KIT	
	33018868	1	LEVER WELDED KIT	
	33018869	1	ROD LEVER KIT	
	33023036	1	FAN COOLING MOTOR ELECTRIC KIT	
	33019625	1	CARBON BRUSH KIT 4PCS	
	33022549	1	MOTOR ELECTRIC AND CABLE EXTENTION KIT (MP)	
	33017361	3	BREAKER CIRCUIT 10A (F1 - F5 - F6)	
	33017357	1	HARNESS REAR COVER	
#	33023124	1	WHEEL SUPERELASTIC GUMASOL 4.00/8 PKD	
	33022519	2	WHEELS SUPERELASTIC 5.00/8 KIT	
	33017376	1	HARNESS MAIN BATTERY	
	33017362	1	HARNESS ELECTRIC MOTOR	
	909 5101 000	1	FUSE 30A (F10)	
	33019166	1	CONNECTOR 350 AMP BLUE (C1)	
	33008583	1	POWER FUSE 250A (F0)	
	33017449	1	CONTACTOR UNIPOLAR 48V (ES0)	
	56382789	1	PANEL FILTER WATER RESISTENT	

OPTIONALS

	REF. NO.	QTY	DESCRIPTION	
	33018889	1	BROOM SIDE PPL 1,5/STEEL	
	33018890	1	BROOM SIDE NYLON 0,5	
	33018856	1	BROOM MAIN SPIRAL NYLON 1.2	
	33018857	1	BROOM MAIN SPIRAL PPL 0.5 WHITE NAVY	
	33018859	1	BROOM MAIN SPIRAL UNION MIX	
	33019173	1	LEFT SIDE BROOM KIT	
	33019377	1	PRE MISTING SYSTEM KIT	
	33019172	1	WHEEL SOLID NON MARKING KIT	
	33019171	1	OVER HEAD GUARD KIT	
	33019176	1	POCKET FILTER KIT 12V	
	33019174	1	TILT STEERING	
	56507740	1	POCKET WATER RESISTANT FILTER	
	56508663	1	SIDE-VIEW MIRRORS FOR USE WITH OHG AND CAB	
	33019554	1	SEAT BELT KIT	
	33019570	1	MAT FLOOR KIT	
	33019572	1	GUARD REAR BUMPER KIT	
	33019560	1	FRONT LIGHT 48V KIT	
	33019573	1	HOPPER STOP KIT	
	56305223	1	PIVOTING LIGHT (BE1)	
	56507830	1	DRIVER'S SIDE WORKING LIGHT	
	56507830	1	REAR WORKING LIGHT	
	56305627	1	HOOD INNER LIGHT	
	56305518	1	CLOGGED AIR FILTER SENSOR	
	56507029	1	HOPPER TEMPERATURE SENSOR	
	56507040	1	SUSPENSION SEAT - ADJUSTABLE BACK TILT - ARM REST - SEAT BELT	
	33020056	1	CLOGGED DUST CONTROL FILTER INDICATOR	
	56507038	1	AMBER STROBE LIGHT (WITHOUT OHG OR CAB)	
	33019571	1	FRONT CORNER GUARDS - FOR BOTH LEFT AND RIGHT CORNERS	
	56507033	1	RAISED ENGINE AIR INTAKE WITH PREFILTER	
	8-83-04016	1	LP TANK WITH OUTAGE AND FILLER VALVE, LP MODELS ONLY	
	56507039	1	AMBER STROBE LIGHT FOR USE WITH OHG	
	33020002	1	SOFT-SIDED CAB FOR WEATHER PROTECTION (MUST ORDER OHG)	
	56507916	1	STRAINER/CHECK VALVE, DUSTGUARD	
	56508709	1	0.1 GALLON (0.379 LITER) PER MIN. NOZZLE TIP FOR HIGH DUST APPL.	
	56507908	1	CAP, DUSTGUARD, YELLOW, TOOLS-FREE	
	33021392	1	FRONT PROTECTION KIT	
	33021975	1	GAS SPRING KIT	



14600 21st Avenue North
Plymouth, MN 55447-3408
www.advance-us.com
Phone: 800-989-2235
Fax: 800-989-6566
©2014 Nilfisk-Advance, Inc.

A Nilfisk-Advance Brand