



## Electronic Service Manuals

This electronic document is provided as a service to our customers. We do not create the contents of the information contained in this document. Should you have detailed questions pertaining to the information contained in this document, you may contact Michco, or the manufacturer which provided the original information in this electronic deliverable. Michco's only part in this electronic deliverable was the electronic assembly process. By providing this manual on line we are not guaranteeing parts availability.

You may contact Michco through the following methods:

Phone (517) 484-9312 or (800) 331-3339

2011 N. High St. -- Lansing, Michigan -- 48906

Fax: (517) 484-9836

Email: [CustServe@Michco.com](mailto:CustServe@Michco.com)

Web site: [www.Michco.Com](http://www.Michco.Com)

Parts Web site: [www.FloorMachineParts.Com](http://www.FloorMachineParts.Com)

Order Parts on Line at:

**[www.FloorMachineParts.Com](http://www.FloorMachineParts.Com)**

Directly to Parts & Service:

By Email: **[Shop@Michco.com](mailto:Shop@Michco.com)**

By Fax: (517) 702-2041

By Voice: Use numbers above.

**Serving the Cleaning Industry Since 1922**

Notice: All copyrighted material remains property of original owners, all trademarks are property of respective owners. Manuals are subject to Manufacturer's reproduction limitations. Originals or reproductions were provided by manufacturers through a request. We make no warranty as to the correctness of information provided in this document and you assume all risk. By placing these manuals on line we are not declaring our corporation to be an manufacturer authorized dealer or provider, please check our web site for authorized manufacturers we represent.

# SW8000

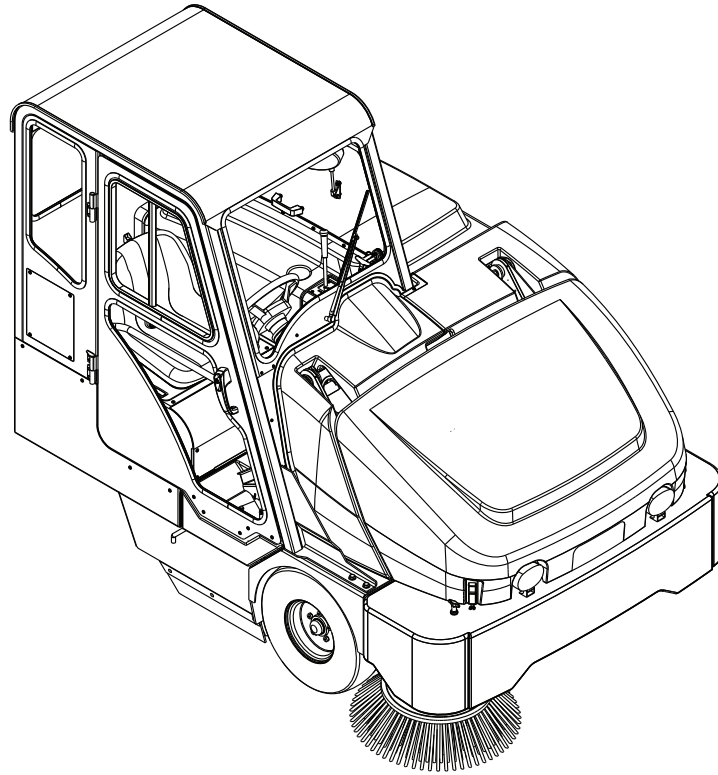

**Instructions For Use - Original Instructions / Instrucciones de uso  
Mode d'emploi / Manual de Utilização**

Cab Addendum / Apéndice de la cabina / Annexe sur la cabine / Anexo de cabine

**Models: 56107509 (4 cyl LPG / cab), 56107507 (4 cyl Gasoline / Petrol / cab)  
56107511 (4 cyl Diesel / cab)**



# Advance

A-English  
B-Español  
C-Français  
D-Português

9/12 Form No. 56091066 REV A

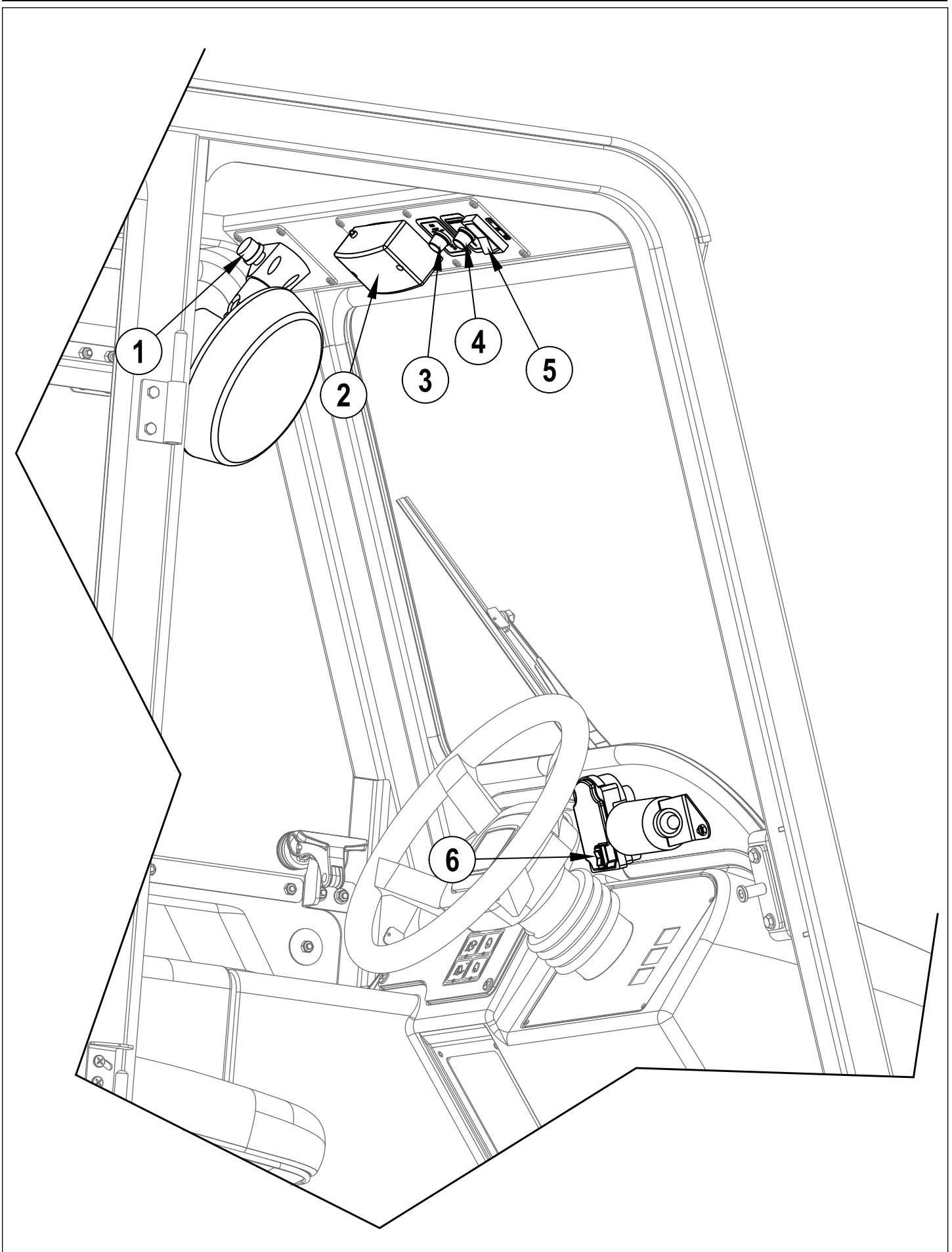

## KNOW YOUR MACHINE

- 1 Cooling Fan Switch
- 2 Dome Light
- 3 Heater-A/C Fan Switch
- 4 Heater-A/C Temperature Control
- 5 A/C ON/OFF Switch
- 6 Windshield Wiper Switch
- 7 Fuel Tank Access Door Latch
- 8 Access Door Latches
- 9 Side Window Latch
- 10 Main Door Latch / Handle
- 11 Seat Panel Latches
- 12 LPG Tank Roll Out Latch

## CONOZCA SU MÁQUINA

- 1 Interruptor del ventilador de refrigeración
- 2 Luz de la cúpula
- 3 Interruptor del ventilador de calefacción-aire acondicionado
- 4 Control de temperatura de calefacción-aire acondicionado
- 5 Interruptor de ENCENDIDO/APAGADO del aire acondicionado
- 6 Interruptor del limpiaparabrisas
- 7 Seguro de la puerta de acceso al depósito de combustible
- 8 Seguros de la puerta de acceso
- 9 Seguro de la ventana lateral
- 10 Seguro/manija de la puerta principal
- 11 Seguros del panel de asientos
- 12 Seguro de rodamiento del depósito de gas

## APPRENEZ À CONNAÎTRE VOTRE MACHINE

- 1 Interrupteur du ventilateur
- 2 Voyant du dôme
- 3 Interrupteur du ventilateur du système de chauffage / climatisation
- 4 Contrôle de la température du système de chauffage / climatisation
- 5 Interrupteur de marche / arrêt de la climatisation
- 6 Interrupteur des essuie-glaces
- 7 Loquet du panneau d'accès au réservoir de carburant
- 8 Loquets des panneaux d'accès
- 9 Loquet de la vitre latérale
- 10 Poignée / loquet du panneau principal
- 11 Loquets de la plaque de siège
- 12 Loquet de glissement du réservoir GPL

## CONHEÇA SUA MÁQUINA

- 1 Botão da ventoinha de refrigeração
- 2 Luz da cúpula
- 3 Botão da ventoinha do A/C e aquecedor
- 4 Controle da temperatura do A/C e aquecedor
- 5 Botão LIGA/DESLIGA A/C
- 6 Botão do limpador de pára-brisa
- 7 Trava da porta de acesso ao tanque de combustível
- 8 Travas da porta de acesso
- 9 Trava da janela lateral
- 10 Trava/manivela da porta principal
- 11 Travas do painel do assento
- 12 Trava do tanque de GLP+

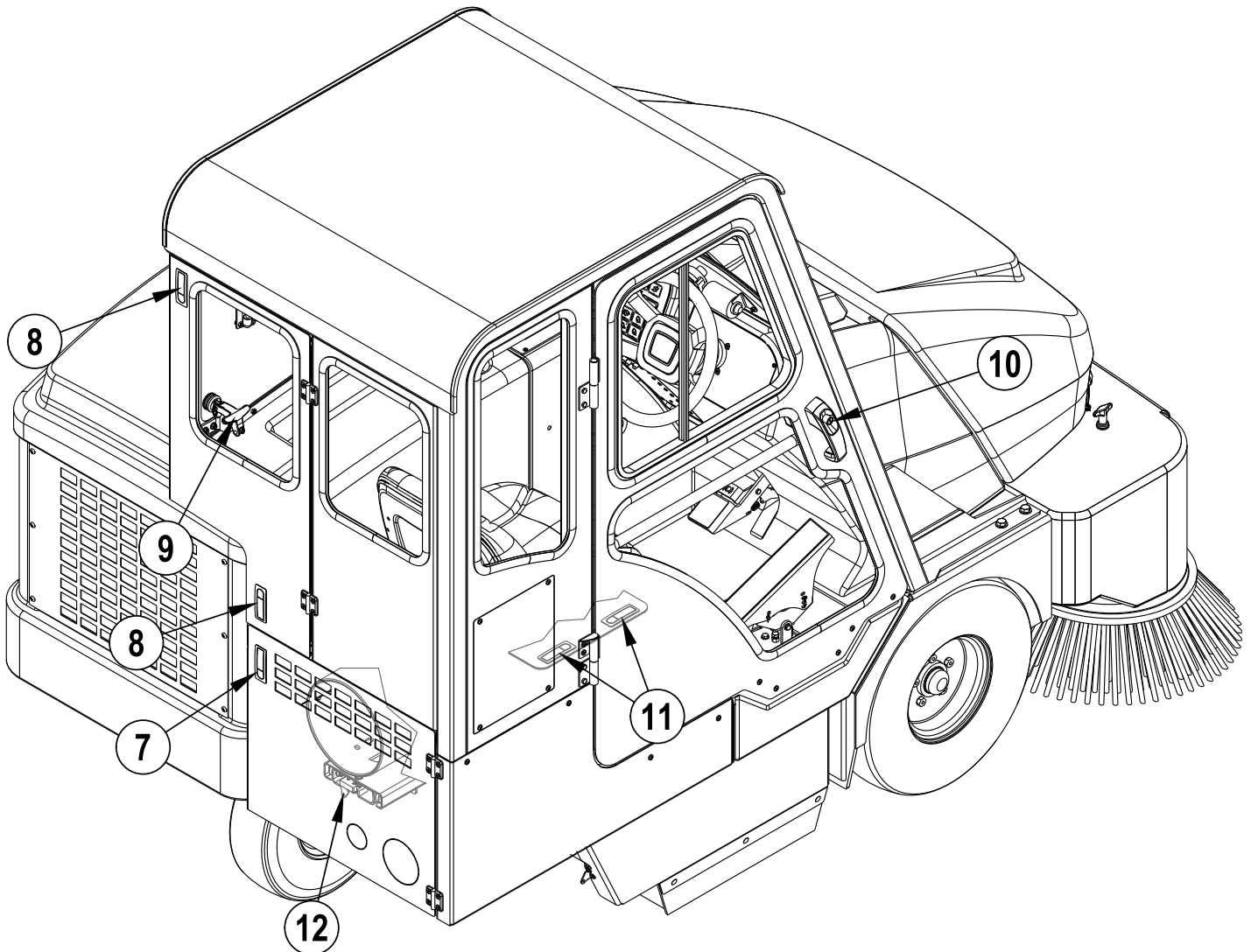



Nilfisk-Advance Equipamentos de Limpeza Ltda.  
Av. Dep. Emílio Carlos, 2.499 - Bairro do Limão - 02721-200  
São Paulo - SP - Brasil  
[www.nilfisk-advance.ind.br](http://www.nilfisk-advance.ind.br)  
[www.plataforma.ind.br](http://www.plataforma.ind.br)  
Tel.: (11) 3959-0300  
Fax: (11) 3959-0306  
©2014 Nilfisk-Advance, Inc.



14600 21st Avenue North  
Plymouth, MN 55447-3408  
[www.advance-us.com](http://www.advance-us.com)  
Phone: 800-989-2235  
Fax: 800-989-6566  
©2014 Nilfisk-Advance, Inc.

---

**A Nilfisk-Advance Brand**