



## **Electronic Service Manuals**

This electronic document is provided as a service to our customers. We do not create the contents of the information contained in this document. Should you have detailed questions pertaining to the information contained in this document, you may contact Michco, or the manufacturer which provided the original information in this electronic deliverable. Michco's only part in this electronic deliverable was the electronic assembly process. By providing this manual online we are not guaranteeing parts availability.

You may contact Michco through the following methods:

**Phone (517) 484-9312**

2011 N. High St. -- Lansing, Michigan -- 48906

Fax: (517) 484-9836

Email: [CustomerService@Michco.com](mailto:CustomerService@Michco.com)

Website: [www.Michco.Com](http://www.Michco.Com)

Order Parts online at:

**[www.Michco.Com](http://www.Michco.Com)**

Directly to Parts & Service:

By Email: **[CustomerService@Michco.com](mailto:CustomerService@Michco.com)**

By Fax: (517) 484-9836

By Voice: (517) 484-9312

**Serving the Cleaning Industry Since 1922**

Notice: All copyrighted material remains property of original owners, all trademarks are property of respective owners. Manuals are subject to Manufacturer's reproduction limitations. Originals or reproductions were provided by manufacturers through a request. We make no warranty as to the correctness of information provided in this document and you assume all risk. By placing these manuals on line we are not declaring our corporation to be an manufacturer authorized dealer or provider, please check our web site for authorized manufacturers we represent.

# FM810 ST, FM810 XP

---

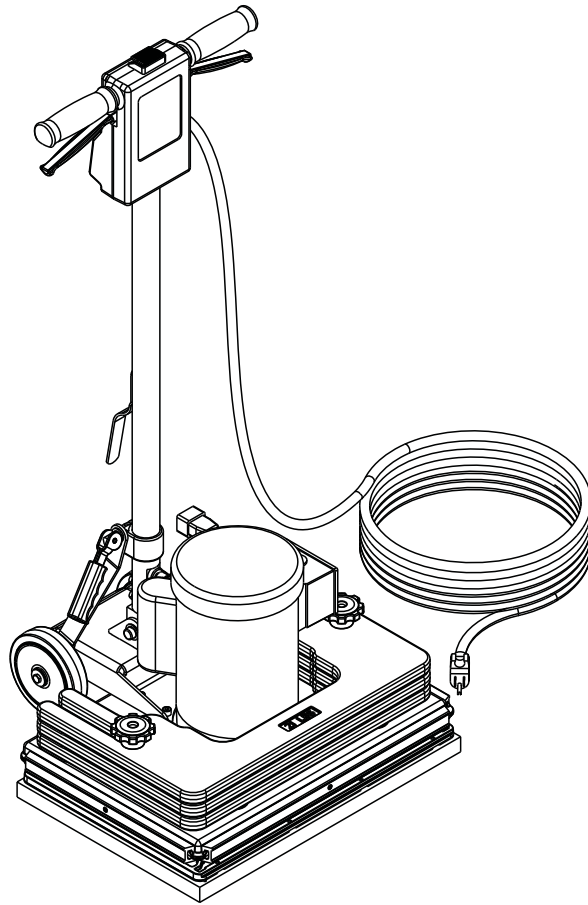

---

## PARTS LIST

**Models: 56105614 (ST), 56105616 (XP)**



**Advance**

## TABLE OF CONTENTS

DESCRIPTION	PAGE
General View and Options .....	1
Handle Assy .....	2-3
Wiring Diagram .....	3
Base Assy-XP .....	4-5
Base Assy-ST .....	6-7

## WHEN ORDERING PARTS

\* Use the part numbers from the "Ref. No." columns in this parts list. If the "Ref. No." column is blank; look under the "Kit" column to identify which kit contains the part in question, then use the kit callout, for example "K1", to find the "Ref. No." for that kit.

Kit	Item	Ref. No.	Qty	Description
K1	1		16	Washer Flat 3/16 Zinc Plat
K1	2		2	Screw-BHS-Brass-10-32x3/8-MS
K1	3		3	Washer EPDM 7/32 X 1/8
	4	805	1	Chain-Cover
	5	905	2	Caster Swivel 4 Gray Non MA
K1	6		2	Nut, Hex Nyl Loc 10-24
K1	7		3	Scr- Hex SS 1/4-20 X .75
K1	8		16	Scr, Hex Hd Loc 1/4-20 x .50
K1	9		3	Wsh, Flt SS .260 X 1.000 X .074
	10	56113012	1	Solution Tank
	11	56113034	2	Hinge Plate
K1		56113103	1	Kit-Hardware Solution Tank

\* Specify the model and serial number of the machine.

\* Use the space below to record the model and serial number for future reference.

Model \_\_\_\_\_ Serial No. \_\_\_\_\_

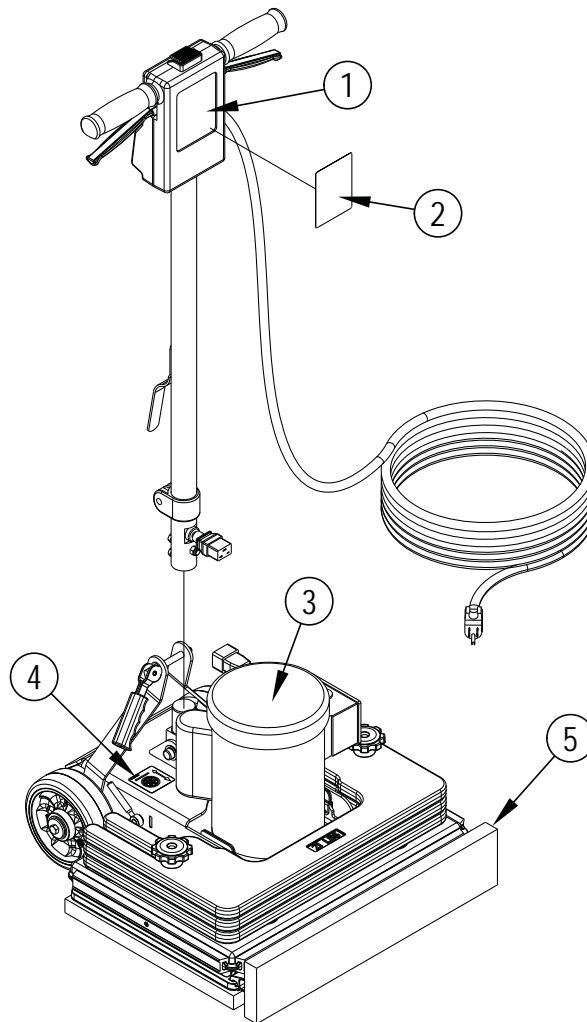

## GENERAL VIEW AND OPTIONS

Item	Ref. No.	Qty	Description
1		1	Handle Assembly-14 X 20
2	56105731	1	Decal-FM810 ST
2	56105732	1	Decal-FM810 XP
3		1	Base Assembly
4	56105756	1	Decal-Wheel-Lock (FM810XP only)
5	56105696	1	Base Board Kit (Std. on XP, optional on ST)

## OPTIONS

*	56105738	1	2.5 Gallon Tank Kit
*	56105696	1	Base Board Kit
*	56105742	1	Vacuum Skirt Kit
*	56105746	1	Isolator-FM810-FM40 Kit
*	56105747	1	Pad-Carpet-Bonnet
*	56105748	1	Pad-Gorilla-800 Grit White 2/Cs
*	56105749	1	Pad-Gorilla-1500 Grit Yellow 2/Cs
*	56105750	1	Pad-Gorilla-3000 Grit Green 2/Cs
*	56105751	1	Pad-Gorilla-8000 Grit Orange 2/Cs
*	56383923	1	Pad-Grout-14x20-4/Cs
*	997022	1	Pad-Black-14x20-5/Cs
*	997021	1	Pad-Blue-14x20-5/Cs
*	997024	1	Pad-Maroon-14x20-10/Cs
*	997020	1	Pad-Red-14x20-5/Cs
*	56105660	1	Pad-Edge-Red-4x20-5/Cs
*	997023	1	Pad-White-14x20-5/Cs

\* = Optional, Not Included

# HANDLE ASSY

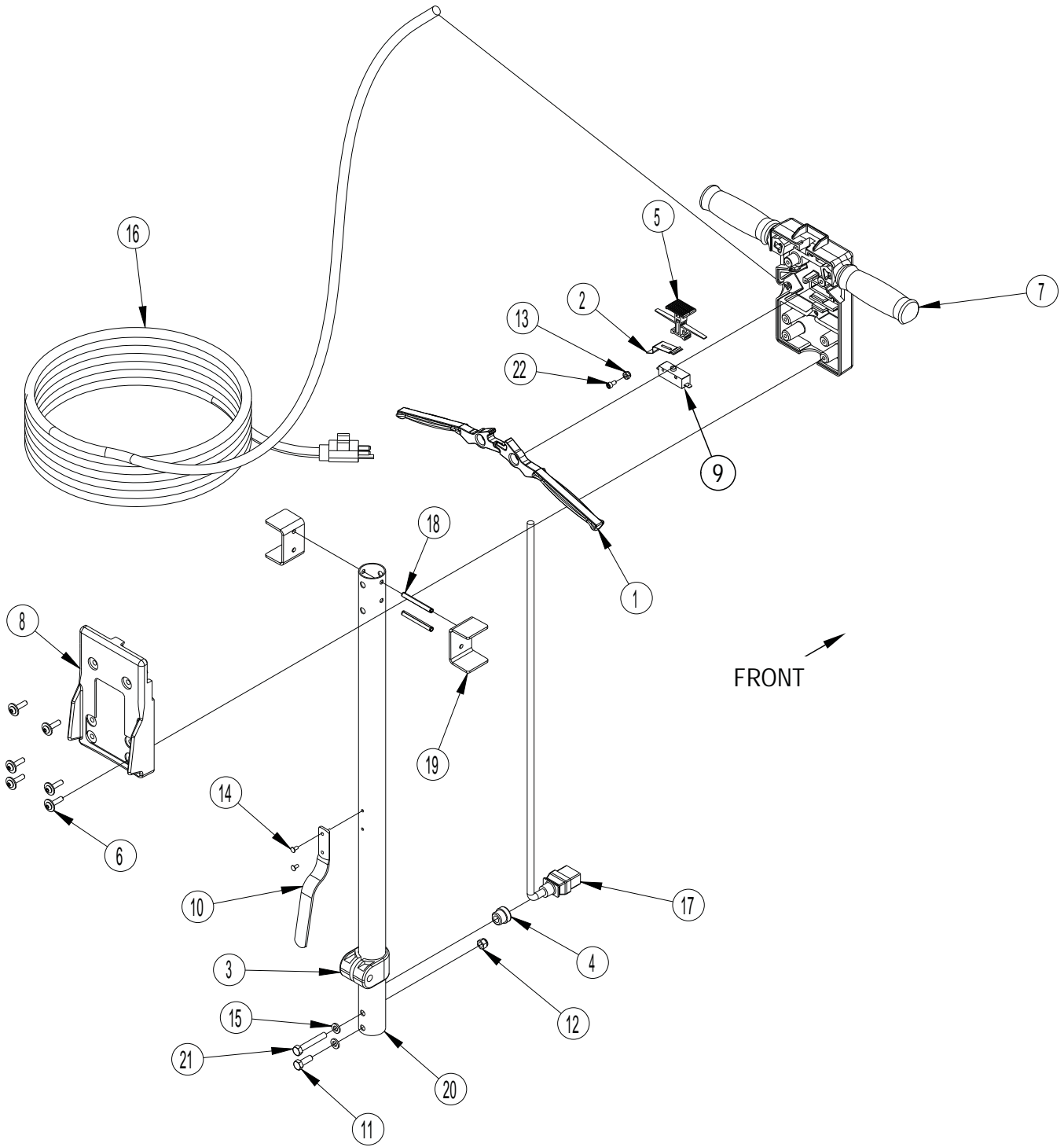

## HANDLE ASSY

Item	Ref. No.	Qty	Description
1	56201027	2	Handle Lever
2	56263648	1	Spring, Plate
3	442001	1	Clamp-Handle Tube
4	627561	1	Strain-Relief
5	56201031	1	Button, Lock
6	80292A	6	Screw .25-20 X 1.00 Bhr Sems
7	56201656	1	Handle, Front
8	56201657	1	Handle, Back
9	40949A	1	Switch Spstno 25a 125vac Ulcsa
10	64325A	1	Hook-Cord
11	85812A	1	Screw 5/16-18 X 7/8 Hex Hd Gr5
12	920110	1	Nut, 5/16-18 Hex Lock
13	920722	1	Nut 10-32 Esna
14	930005	2	Rivet 5/32 X .32
15	980652	2	Washer, 5/16 Lock
16	40760A	1	Cord Power
17	56382460	1	Cord-No Relief Interconnect
18	53834A	2	Pin, Coiled
19	61726A	2	Support, Handle Mnt
20	61825A	1	Tube-Handle
21	85817A	1	Screw 5/16-18 X 2.00 Hex HD GR5
22	80290A	1	Screw 10-32 X .38 HRCS

## WIRING DIAGRAM

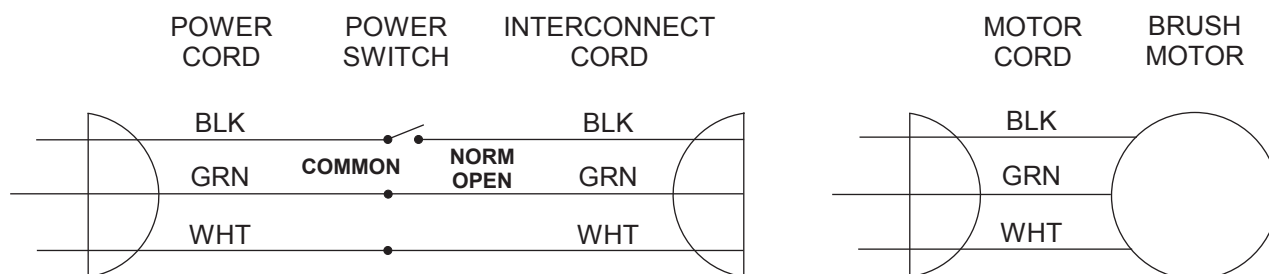

## BASE ASSY-XP

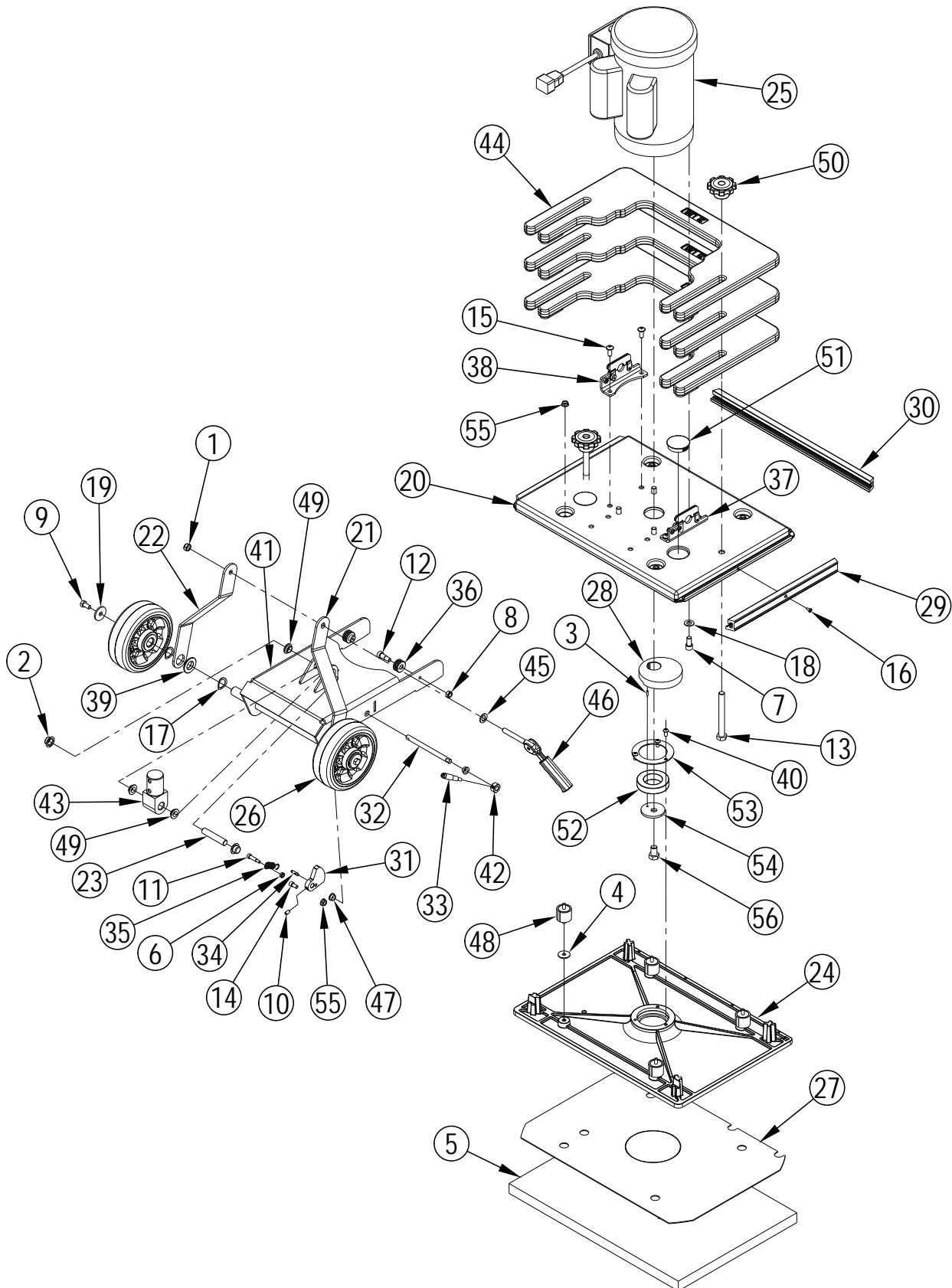

## BASE ASSY-XP

Kit	Item	Ref. No.	Qty	Description
	1	56002841	1	Nut Hex Nyl Loc-Thin 3/8-16
	2	920346	2	Palnut #Pw500015 Type W
	3	925589	1	Pin, Roll
K1	4	56009002	4	Washer Flat .266x.906x.060
	5	997020	1	Boost 20 Red Pad
	6	56002832	1	Nut, Hex Nyl Loc-Thin 10-24
	7	86112A	4	Screw-3/8-16 X 3/4-socket Head
	8	56002851	2	Nut, Hex Nyl Loc-Thin Ss 5/16-18
	9	56002929	2	Scr-Hex Hd Loc 5/16-18x.62
	10	56002930	1	Scr, Soc Set Loc 1/4-20 X .38
	11	56003972	1	Scr-Soc Shd Ss .25x.75x10-24
	12	56003818	2	Scr-Soc Shd Ss .38 X .50 X 5/16-18
	13	56003910	2	Scr-Hex FT SS M12-1.75 X 110mm
	14	56002115	2	Scr Soc Hd 1/4-20 X .50
	15	56003968	4	Scr-Soc Hd 5/16-18x.75 Tapt li
	16	56003969	3	Scr-Soc Hd #8-32x.38 Tapt li
	17	56009021	4	Wsh, Bowed .781x1.062x.014
	18	56009112	4	Wsh, Int Shprf 3/8
	19	56009294	2	Wsh, Flt .354 X 1.247 X .120
	20	56105630	1	Frame-Main
	21	56105631	1	Link-Arm-Right-Lx
	22	56105632	1	Link-Arm-Left-Lx
	23	56105637	1	Pin-Handle
	24	56105639	1	Base-Orbital
	25	56105645	1	Motor-1.5 HP
	[ ]	41312A	1	Capacitor, 400- 480 Mfd 125v
	[ ]	56105715	1	Switch - Power -Motor
	[ ]	56105717	1	Capacitor - Run -Motor
	[ ]	56105718	1	Thermal -Overload -Motor
	[ ]	56105719	1	Boot - Rubber -Motor
	[ ]	56105720	1	Cord -Iec -Motor
	26	56105651	2	Wheel-2x6
	27	56105652	1	Pad-Grip Orbital-Base
	28	56105654	1	Eccentric-Ranger
	29	56105661	2	Bumper-Side

Kit	Item	Ref. No.	Qty	Description
	30	56105662	1	Bumper-Front
	31	56105665	1	Cam-Lock
	32	56105666	1	Shaft-Lift
	33	56105755	1	Lift Lever Assembly
	34	56105670	1	Pin-Groove
	35	56105671	1	Spring-Lift
	36	56105673	2	Bushing-Release
	37	56105681	1	Latch Assy-Right
	38	56105685	1	Latch Assy-Left
	39	56105694	2	Bushing-Link Arm
	40	87700A	3	Screw 1/4-20 X 1/2 B.H.
	41	56105699	1	Wheel Chassis Weldment Lx
	42	56105700	1	Collar-Shaft
	43	56105711	1	Tongue-Handle-Tube
	44	56105713	3	Weight Assembly
	45	56105727	1	Washer-Wear-Cam
	46	56109699	1	Cam Assy With Grip
	47	56303285	2	Bearing, FL .500x.375x.250
K1	48		4	Isolator-1.25 30 Duro 1/4-20
	49	56413211	4	Bearing, Flange .625 X .500 X .250
	50	56380149	2	Knob-M12-1.75 Thru
	51	56105753	2	Plug-1-3/4in Hole
	52	50736A	1	Bearing
	53	66981A	1	Retainer Bearing Obs-18
	54	66982A	1	Retainer Eccentric Obs-18
K1	55	81220A	5	Nut, Serrated Flange
	56	85718A	1	Scr 1/2-13 X 3/4 Hc St Grd 2

Service Kits

K1 56105746 1 Isolator-FM810-FM40 Kit

[ ] = Not Shown

## BASE ASSY-ST

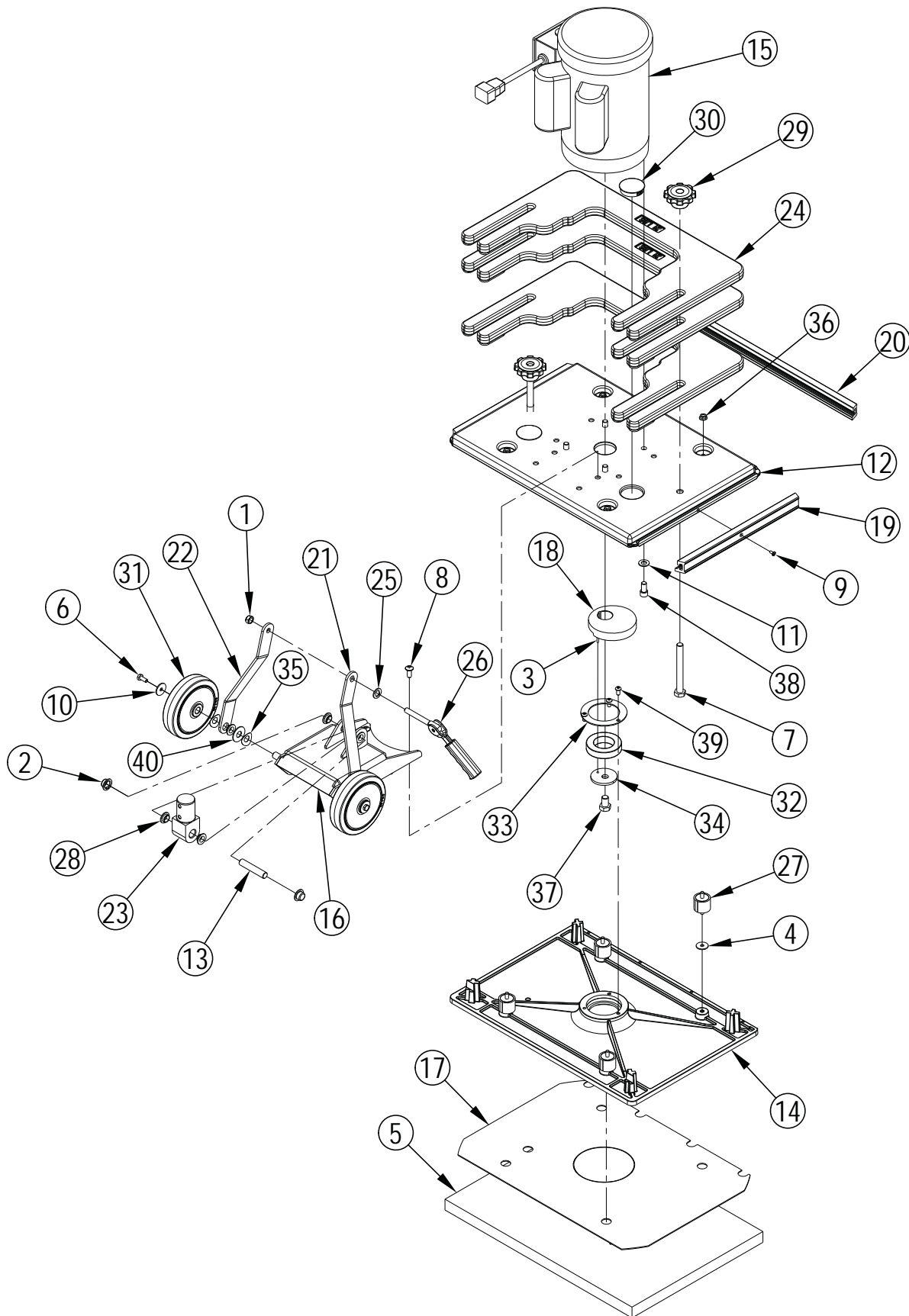

## BASE ASSY-ST

Item	Ref. No.	Qty	Description
	1	56002841	1 Nut Hex Nyl Loc-Thin 3/8-16
	2	920346	2 Palnut #Pw500015 Type W
	3	925589	1 Pin, Roll
K1	4	56009002	4 Washer Flat .266x.906x.060
	5	997020	1 Boost 20 Red Pad
	6	56002922	2 Scr-Hex Hd Loc 1/4-20x.62
	7	56003910	2 Scr-Hex FT SS M12-1.75 X 110mm
	8	56003968	4 Scr-Pan Phil 5/16-18x.75 Tapt
	9	56003969	3 Scr-Soc Hd #8-32x.38 Tapt li
	10	56009060	2 Wsh-Flt Ss .260 X 1.000 X .074
	11	56009112	4 Wsh, Int Shprf 3/8
	12	56105630	1 Frame-Main
	13	56105637	1 Pin-Handle
	14	56105639	1 Base-Orbital
	15	56105645	1 Motor-1.5 HP
	[ ]	41312A	1 Capacitor, 400- 480 Mfd 125v
	[ ]	56105715	1 Switch - Power -Motor
	[ ]	56105717	1 Capacitor - Run -Motor
	[ ]	56105718	1 Thermal -Overload -Motor
	[ ]	56105719	1 Boot - Rubber -Motor
	[ ]	56105720	1 Cord -Iec -Motor
	16	56105646	1 Wheel Chassis Weldment
	17	56105652	1 Pad-Grip Orbital-Base
	18	56105654	1 Eccentric-Ranger
	19	56105661	2 Bumper-Side
	20	56105662	1 Bumper-Front
	21	56105709	1 Link-Arm-Right
	22	56105710	1 Link-Arm-Left
	23	56105711	1 Tongue-Handle-Tube
	24	56105713	3 Weight Assembly
	25	56105727	1 Washer-Wear-Cam
	26	56109699	1 Cam Assy With Grip
K1	27		4 Isolator-1.25 30 Duro 1/4-20
	28	56413211	6 Bearing, Flange .625 X .500 X .250
	29	56380149	2 Knob-M12-1.75 Thru
	30	56105753	2 Plug-1-3/4in Hole
	31	39857A	2 Wheel 5 X 1.50 X .500
	32	50736A	1 Bearing
	33	66981A	1 Retainer Bearing Obs-18
	34	66982A	1 Retainer Eccentric Obs-18
	35	80295A	4 Washer Bowed
K1	36	81220A	4 Nut, Serrated Flange
	37	85718A	1 Scr 1/2-13 X 3/4 Hc St Grd 2
	38	86112A	4 Screw-3/8-16 X 3/4-Socket Head
	39	87700A	3 Screw 1/4-20 X 1/2 B.H.
	40	87607A	2 Washer Flt 1.25x.52x.06 Nylon

Service Kits

K1 56105746 1 Isolator-FM810-FM40 Kit

[ ] = Not Shown







Nilfisk-Advance Equipamentos de Limpeza Ltda.  
Av. Dep. Emílio Carlos, 2.499 - Bairro do Limão - 02721-200  
São Paulo - SP - Brasil  
[www.nilfisk-advance.ind.br](http://www.nilfisk-advance.ind.br)  
[www.plataforma.ind.br](http://www.plataforma.ind.br)  
Tel.: (11) 3959-0300  
Fax: (11) 3959-0306  
©2015 Nilfisk-Advance, Inc.



14600 21st Avenue North  
Plymouth, MN 55447-3408  
[www.advance-us.com](http://www.advance-us.com)  
Phone: 800-989-2235  
Fax: 800-989-6566  
©2015 Nilfisk-Advance, Inc.

---

**A Nilfisk-Advance Brand**