



## Electronic Service Manuals

This electronic document is provided as a service to our customers. We do not create the contents of the information contained in this document. Should you have detailed questions pertaining to the information contained in this document, you may contact Michco, or the manufacturer which provided the original information in this electronic deliverable. Michco's only part in this electronic deliverable was the electronic assembly process. By providing this manual on line we are not guaranteeing parts availability.

You may contact Michco through the following methods:

Phone (517) 484-9312 or (800) 331-3339

2011 N. High St. -- Lansing, Michigan -- 48906

Fax: (517) 484-9836

Email: [CustServe@Michco.com](mailto:CustServe@Michco.com)

Web site: [www.Michco.Com](http://www.Michco.Com)

Parts Web site: [www.FloorMachineParts.Com](http://www.FloorMachineParts.Com)

Order Parts on Line at:

**[www.FloorMachineParts.Com](http://www.FloorMachineParts.Com)**

Directly to Parts & Service:

By Email: **[Shop@Michco.com](mailto:Shop@Michco.com)**

By Fax: (517) 702-2041

By Voice: Use numbers above.

**Serving the Cleaning Industry Since 1922**

Notice: All copyrighted material remains property of original owners, all trademarks are property of respective owners. Manuals are subject to Manufacturer's reproduction limitations. Originals or reproductions were provided by manufacturers through a request. We make no warranty as to the correctness of information provided in this document and you assume all risk. By placing these manuals on line we are not declaring our corporation to be an manufacturer authorized dealer or provider, please check our web site for authorized manufacturers we represent.

# SC400

---



---

## ***Service Manual***

**Advance SC400 9087310020**

**Nilfisk SC400 9087311020**

**Nilfisk SC400 9087318020**



**English**

**2012-11 Form No. 9099624000**

# Table of Contents

---

<b>Table of Contents</b> . . . . .	<b>2</b>
<b>General Information</b> . . . . .	<b>4</b>
Machine General Description . . . . .	4
Service Manual Purpose and Field of Application . . . . .	4
Other Reference Manuals . . . . .	4
Conventions. . . . .	5
Service and Spare Parts . . . . .	5
Serial Number Label . . . . .	5
Safety . . . . .	6
Symbols . . . . .	6
General Instructions . . . . .	6
Machine Lifting. . . . .	9
Machine Transportation . . . . .	9
Machine Nomenclature (know your machine) . . . . .	10
Handlebar with Control Panel. . . . .	12
Service and Diagnostic Equipment . . . . .	13
Technical Data . . . . .	14
Dimensions . . . . .	15
Maintenance . . . . .	16
Scheduled Maintenance Table. . . . .	16
<b>Control System</b> . . . . .	<b>17</b>
Functional Description. . . . .	17
Wiring Diagram . . . . .	18
Component Locations . . . . .	19
Removal and Installation . . . . .	20
Specifications . . . . .	24
Controls and Functions . . . . .	29
<b>Electrical System</b> . . . . .	<b>32</b>
Functional Description. . . . .	32
Fuses . . . . .	32
Wiring Diagram . . . . .	32
Component Locations . . . . .	33
Maintenance and Adjustments . . . . .	34
Troubleshooting . . . . .	38
Machine Wiring Diagram . . . . .	39
Specifications . . . . .	40
<b>Recovery System</b> . . . . .	<b>41</b>
Functional Description. . . . .	41
Wiring Diagram . . . . .	41
Component Locations . . . . .	42
Maintenance and Adjustments . . . . .	43
Troubleshooting . . . . .	44
Removal and Installation . . . . .	45
Specifications . . . . .	48

<b>Scrub System, Disc . . . . .</b>	<b>49</b>
Functional Description . . . . .	.49
Wiring Diagram . . . . .	.49
Component Locations . . . . .	.50
Maintenance and Adjustments . . . . .	.51
Troubleshooting . . . . .	.53
Removal and Installation . . . . .	.54
Specifications . . . . .	.60
<b>Solution System . . . . .</b>	<b>61</b>
Functional Description . . . . .	.61
Wiring Diagram . . . . .	.61
Component Locations . . . . .	.62
Maintenance and Adjustments . . . . .	.63
Troubleshooting . . . . .	.64
Specifications . . . . .	.64
<b>Squeegee System . . . . .</b>	<b>65</b>
Functional Description . . . . .	.65
Component Locations . . . . .	.66
Maintenance and Adjustments . . . . .	.67
Troubleshooting . . . . .	.69
Removal and Installation . . . . .	.70
Specifications . . . . .	.71
<b>Wheel System, Non-Traction . . . . .</b>	<b>72</b>
Component Locations . . . . .	.72
Specifications . . . . .	.73

## General Information

---

### Machine General Description

The SC400 is a “man-down” industrial machine designed to wash and dry floors, in civil or industrial environments, in one pass. The machine is powered by on-board batteries. The machine is equipped with a single disc brush, a controlled solution flow dosing system and a rear squeegee with blades, which dries the floor by vacuuming the dirty water.

### Service Manual Purpose and Field of Application

The Service Manual is a technical resource intended to help service technicians when carrying out maintenance and repairs on the SC400, to guarantee the best cleaning performance and a long working life for the machine.

Please read this manual carefully before performing any maintenance and repair procedure on the machine.

### Other Reference Manuals

Model	Product Code	User Manual	Spare Parts List
Nilfisk SC400	9087311020	9099612000	9099613000
Nilfisk SC400	9087318020		
Advance SC400	9087310020	9099626000	9099627000

These manuals are available at:

- Local Nilfisk-Advance Retailer
- Nilfisk-Advance website: [www.nilfisk.com](http://www.nilfisk.com) - [www.advance-us.com](http://www.advance-us.com)

### Conventions

Forward, backward, front, rear, left or right are intended with reference to the operator’s position, that is to say in driving position with the hands on the handlebar.

### Service and Spare Parts



Service and repairs must be performed only by authorised personnel or Nilfisk Service Centers. The authorised personnel is trained directly at the manufacturer’s premises and has original spare parts and accessories. Contact Nilfisk Retailer indicated below for service or to order spare parts and accessories, specifying the machine model and serial number.

(Apply Retailer label here)

### Serial Number Label

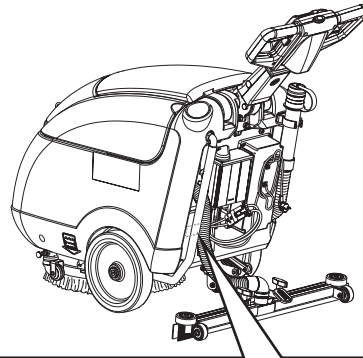
The machine model name and serial number are marked on the plate (see the example to the side). Product number and year of production are marked on the same plate. This information is useful when requiring machine spare parts. Use the following table to write down the machine identification data.



Model: Scrubber-Dryer SC400 17 B		Serial No: .....
<b>Prod. Nr: 9087310020</b>		Date code: .....
GVW: 136 kg/300 lb	IPX4	LpA = 65 dB(A)
29 A	Charg. 110-240Vac 50-60 Hz	Battery 24 Vdc
Type E Scrubber Dryer		
Conform to: UL STD 583		
Certified to: CSA STD C22.2 N.68-92	Intertek 3084826	
 A Nilfisk-Advance Brand		"Made in Hungary" Nilfisk-Advance, Inc. Plymouth, MN, USA www.advance-us.com

Model .....
Product Nr. ....
Serial No. ....

## Safety

The following symbols indicate potentially dangerous situations. Always read this information carefully and take all necessary precautions to safeguard people and property.

### Symbols



**Danger!** *It indicates a dangerous situation with risk of death for the operator.*



**Warning!** *It indicates a potential risk of injury for people or damage to objects.*



**Caution!** *It indicates a caution related to important or useful functions.*



**Note:** *It indicates a remark related to important or useful functions.*

### General Instructions

Specific warnings and cautions to inform about potential damages to people and machine are shown below.



**Warning!** *Make sure to follow the safety precautions to avoid situations that may lead to serious injuries.*

- Before performing any cleaning, maintenance, repair or replacement procedure, turn the program selection knob to “0” and disconnect the battery connector.
- This machine must be used by properly trained operators only.
- Do not wear jewels when working near electrical components.
- Do not work under the lifted machine, if it is not securely fixed.
- Do not operate the machine near toxic, dangerous, flammable and/or explosive powders, liquids or vapors. This machine is not suitable for collecting dangerous powders.
- (For WET batteries only). Keep the battery away from sparks, flames and incandescent material. During the normal operation explosive gases are released.
- (For WET batteries only). Battery charging produces highly explosive hydrogen gas. Keep the battery cover open during battery charging and perform this procedure in well-ventilated areas and away from naked flames.



**Caution!** *Make sure to follow the safety precautions to avoid situations that may lead to serious injuries, damages to materials or equipments.*

- Carefully read all the instructions before performing any maintenance/repair procedure.
- Before using the battery charger, ensure that frequency and voltage values, indicated on the machine serial number plate, match the mains voltage.
- Do not pull or carry the machine by the battery charger cable and never use the battery charger cable as a handle. Do not close a door on the battery charger cable, or pull the battery charger cable around sharp edges or corners. Do not run the machine on the battery charger cable.
- To reduce the risk of fire, electric shock, or injury, do not leave the machine unattended when it is plugged in.
- Keep the battery charger cable away from heated surfaces.
- Before performing any maintenance procedure, disconnect the battery charger cable from the electrical mains to avoid any risk of fire, electric shock or injuries.
- Do not smoke while charging the batteries.
- Always protect the machine against the sun, rain and bad weather, both under operation and inactivity condition. Store the machine indoors, in a dry place.
- Before using the machine, close all doors and/or covers.
- This machine is not intended for use by persons (including children) with reduced physical, sensory or mental capabilities, or lack of experience and knowledge, unless they have been given supervision or instruction concerning use of the machine by a person responsible for their safety. Children should be supervised to ensure that they do not play with the machine.
- Close attention is necessary when used near children.
- Use only as shown in this Manual. Use only Nilfisk's recommended accessories.
- Check the machine carefully before each use, always check that all the components have been assembled before use. If the machine is not perfectly assembled it can cause damages to people and properties.
- Take all necessary precautions to prevent hair, jewels and loose clothes from being caught by the machine moving parts.
- Do not use the machine on slopes with a gradient exceeding the specifications.
- Do not use the machine on incline.
- Do not tilt the machine more than the angle indicated on the machine itself, in order to prevent instability.
- Do not use the machine in particularly dusty areas.
- Use the machine only where a proper lighting is provided.
- While using this machine, take care not to cause damage to people or objects.
- Do not bump into shelves or scaffoldings, especially where there is a risk of falling objects.
- Do not lean liquid containers on the machine, use the relevant can holder.
- The machine working temperature must be between 0°C and +40°C.
- The storage temperature must be between 0°C and +40°C.
- The humidity must be between 30% and 95%.
- When using floor cleaning detergents, follow the instructions on the labels of the detergent bottles.
- To handle floor cleaning detergents, wear suitable gloves and protections.
- Do not use the machine as a means of transport; do not push/tow it.
- Do not allow the brush to operate while the machine is stationary to avoid damaging the floor.
- In case of fire, use a powder fire extinguisher, not a water one.
- Do not tamper with the machine safety guards and follow the ordinary maintenance instructions scrupulously.
- Do not allow any object to enter into the openings. Do not use the machine if the openings are clogged. Always keep the openings free from dust, hairs and any other foreign material which could reduce the air flow.
- Do not remove or modify the plates affixed to the machine.
- This machine cannot be used on roads or public streets.
- Pay attention during machine transportation when temperature is below freezing point. The water in the recovery tank or in the hoses could freeze and seriously damage the machine.

- Use only brushes supplied with the machine or those specified in the User Manual. Using other brushes could reduce safety.
- If parts must be replaced, require ORIGINAL spare parts from an Authorised Dealer or Retailer.
- Do not wash the machine with direct or pressurised water jets, or with corrosive substances.
- The machine must be disposed of properly, because of the presence of toxic-harmful materials (batteries, oils, etc.), which are subject to standards that require disposal in special centres (see the User Manual).
- (For WET batteries only). When lead (WET) batteries are installed on the machine, do not tilt the machine for more than 30° from the horizontal plane to prevent the highly corrosive acid from leaking out of the batteries. If the machine must be tilted to perform any maintenance procedure, remove the batteries.

## Machine Lifting



**Warning!** Do not work under the lifted machine, if it is not securely fixed.

## Machine Transportation



**Warning!** Before transporting the machine, make sure that:

*All covers are closed.*

*The recovery tank and the detergent tank are empty.*

*The batteries are disconnected.*

*The machine is securely fastened to the means of transport.*

## Machine Nomenclature (know your machine)

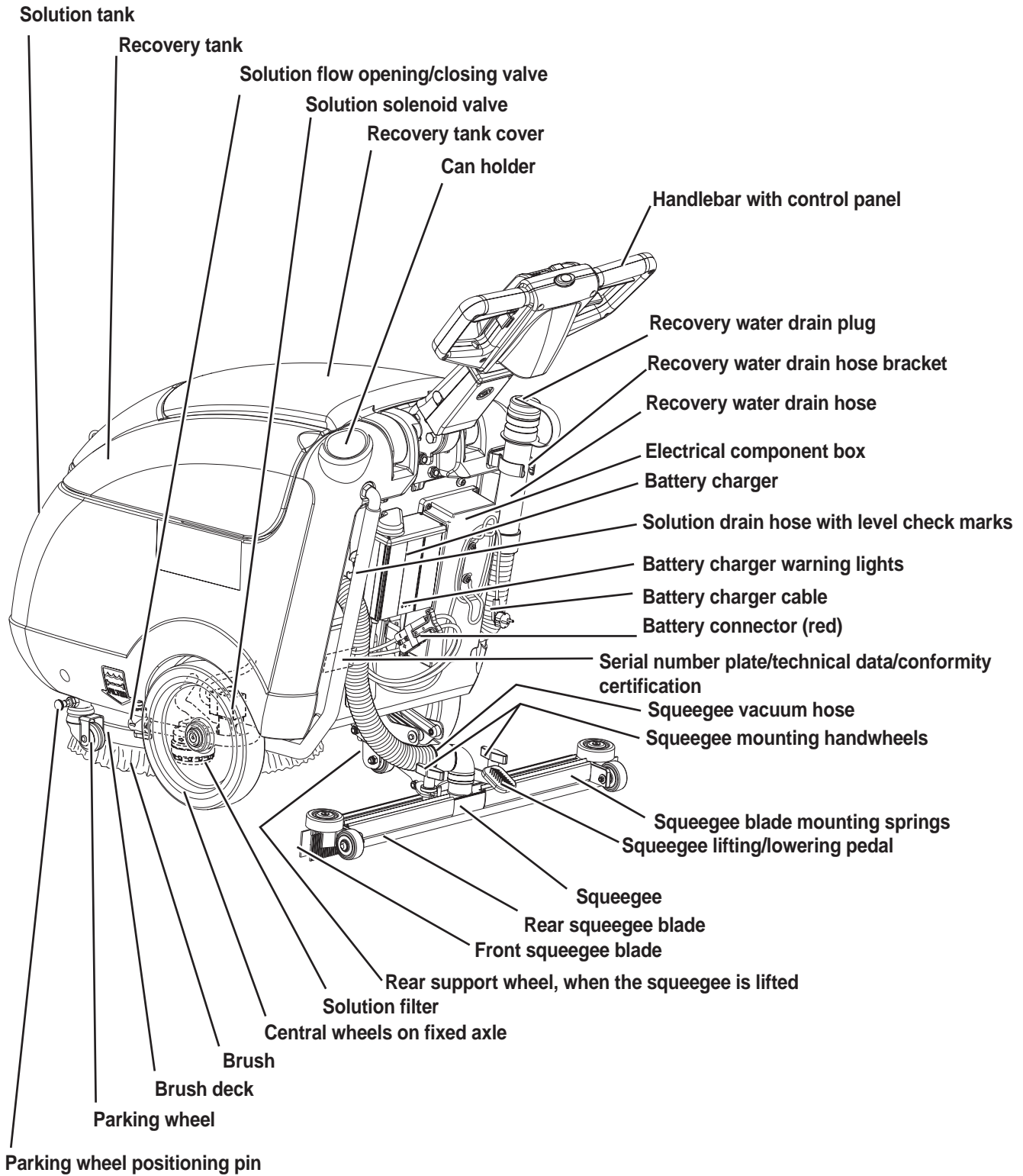

### Machine Nomenclature (Continues)

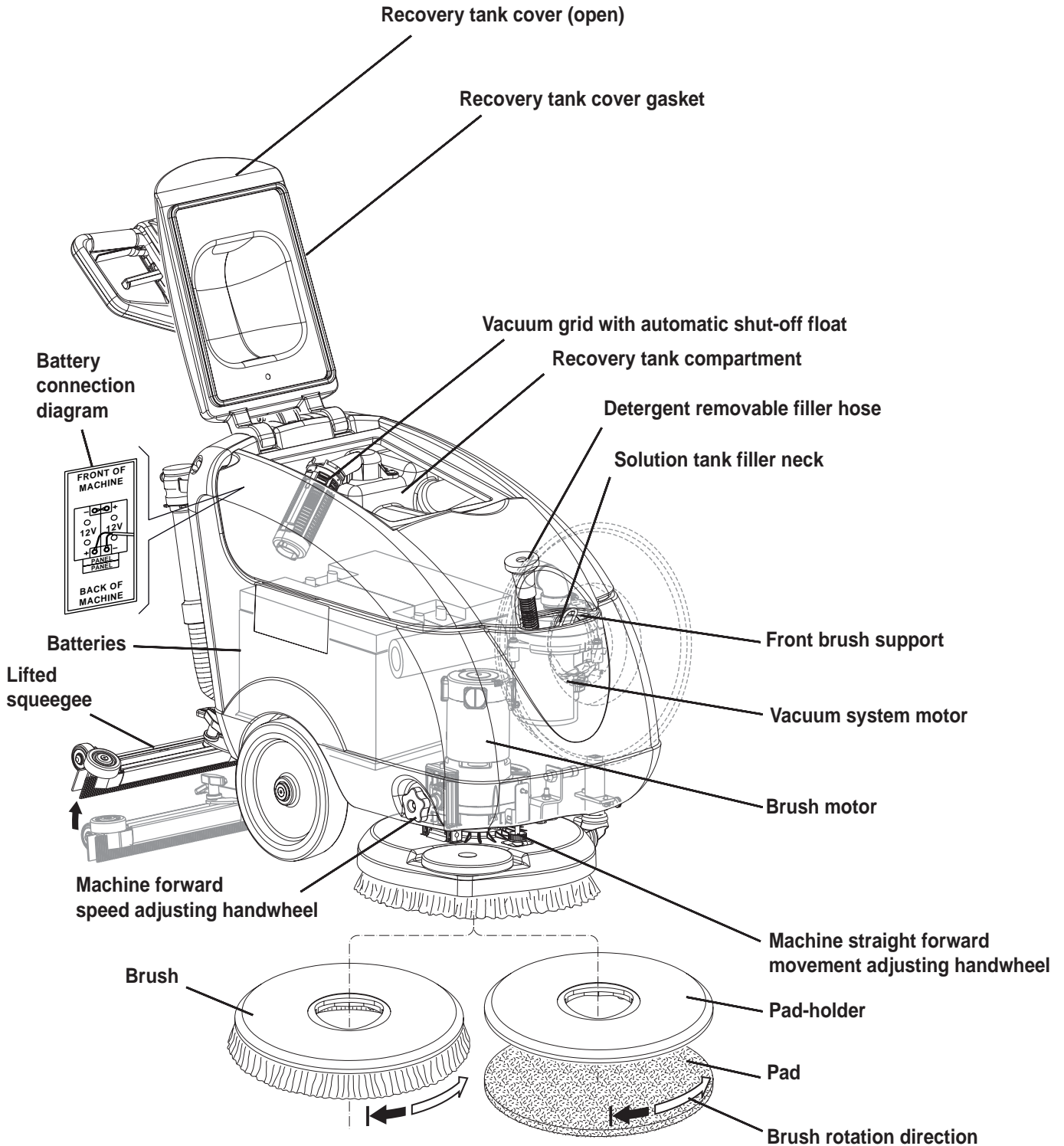

## Handlebar with Control Panel

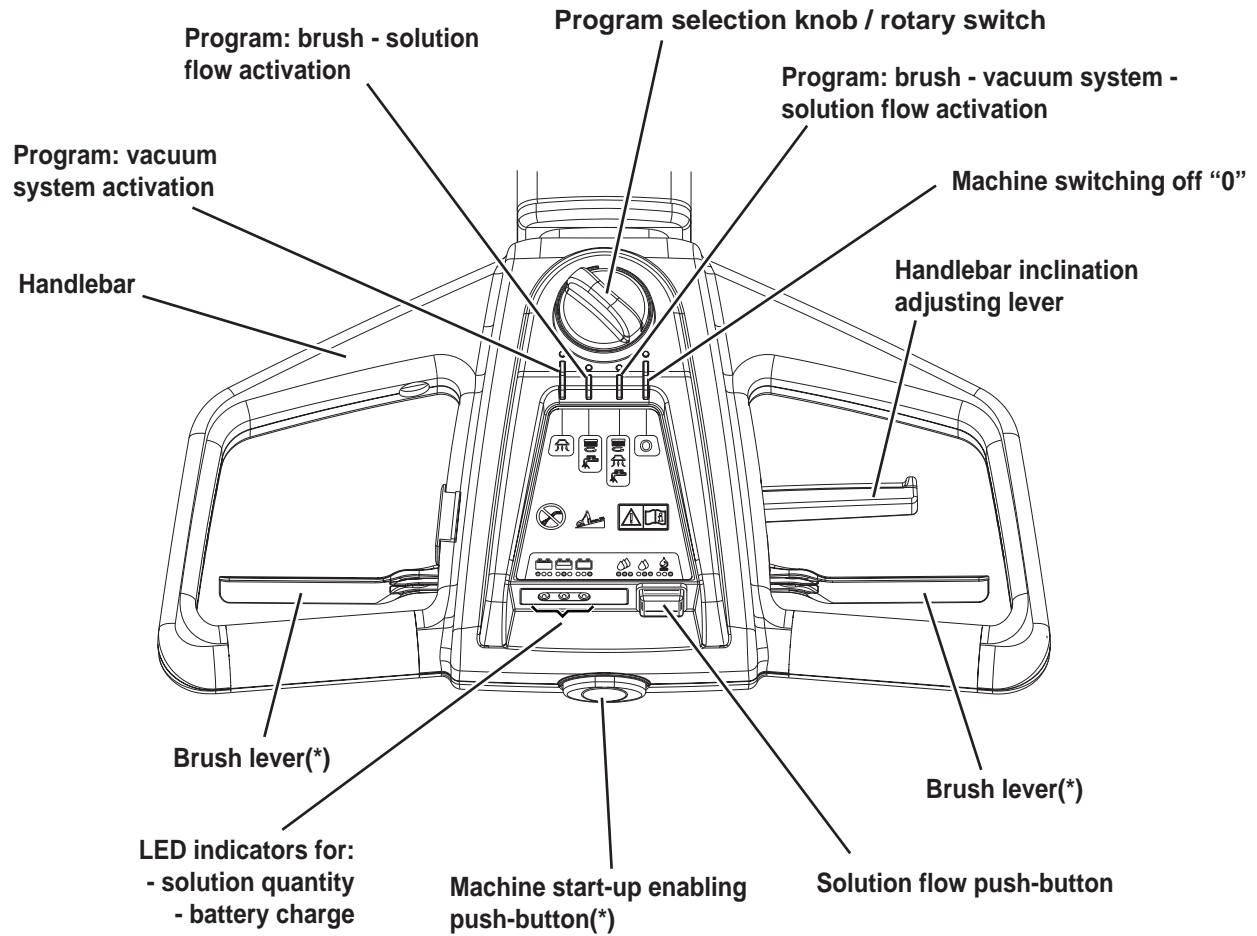

(\*) The brush levers operate only after pushing the machine start-up enabling push-button

## Service and Diagnostic Equipment

Besides a complete set of standard meters, the following instruments are necessary to perform fast checks, maintenance and repairs on Nilfisk-Advance machines:

Besides a complete set of standard meters, the following instruments are necessary to perform fast checks and repairs on Nilfisk-Advance machines:

- Laptop computer charged with the current version of EzParts, Adobe Reader and (if possible) Internet connection
- Digital Volt Meter (DVM)
- Amp clamp with possibility of making DC measurements
- Hydrometer
- Battery charge tester to check 12V batteries
- Static control wrist strap
- Dynamometric wrench set
- A copy of the User Manual and Spare Parts List of the machine to be serviced (provided with the machine or available at [www.advance-us.com](http://www.advance-us.com) or other Nilfisk-Advance websites).

The following equipment is also available at Nilfisk-Advance Centers:

- Vacuum water lift gauge, P/N 56205281

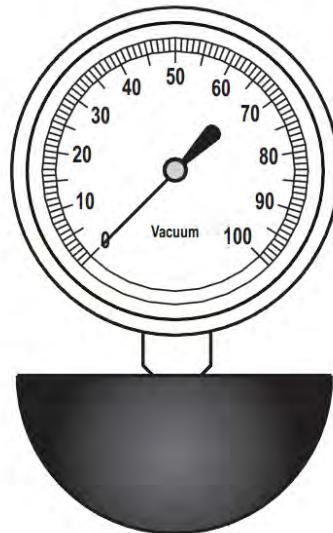

## Technical Data

General	Advance SC400 17 B	Nilfisk SC400 43 B FULL PKG	Nilfisk SC400 43 B
Solution tank capacity	6.0 US gal (23 liters)		
Recovery tank capacity	5.5 US gal (21 liters)		
Machine length	48.4 in (1,230 mm)		
Machine width with squeegee	28.3 in (720 mm)		
Machine width without squeegee	22.4 in (570 mm)		
Min/max machine height with adjustable handlebar	28.5 - 43.9 in (725 - 1,115 mm)		
Minimum turning radius	29.5 in (750 mm)		
Cleaning width	17 in (430 mm)		
Diameter of wheels on fixed axle	9.8 in (250 mm)		
Wheel pressure on the floor	290 psi (2 N/mm <sup>2</sup> )		
Brush/pad diameter	17 in (430 - 432 mm)		
Brush pressure with full tank and lowered squeegee	77 lb (35 kg)		
Min/max solution flow	0.1 / 0.42 gpm (0.4 / 1.6 liters/min)		
Sound pressure level at workstation (ISO 11201, ISO 4871, EN 60335-2-72) (LpA)	65 dB(A) ± 3 dB(A)		
Machine sound pressure level (ISO 3744, ISO 4871, EN 60335-2-72) (LwA)	89 dB(A)		
Vibration level at the operator's arms (ISO 5349-1, EN 60335-2-72)	< 98.4 in/s <sup>2</sup> (< 2.5 m/s <sup>2</sup> )		
Maximum gradient when working	2%		
IP protection class	X4		
Protection class (electric)	III		
Vacuum system motor power	0.4 hp (300 W)		
Vacuum water lift (blocked)	47.2 inH <sub>2</sub> O (1,200 mmH <sub>2</sub> O)		
Brush motor power	0.6 hp (450 W)		
Brush motor speed	155 rpm		
Total absorbed power	29 A (0.75 kW)		
Battery compartment size	13.7x17.7x10.2 in (350x350x260 mm)		
Battery voltage	24V		
Standard batteries (2)	-	12V - 50 Ah C5 (AGM) Spiracell	-
Battery charger	100-240 VAC		
Work autonomy (standard batteries)	1.5 hour		
Weight without batteries and with empty tanks	130 lb (59 kg)		
Gross vehicle weight (GVW)	300 lb (136 kg)		
Shipping weight	179 lb / 81 kg	267 lb / 121 kg	179 lb / 81 kg

## Dimensions

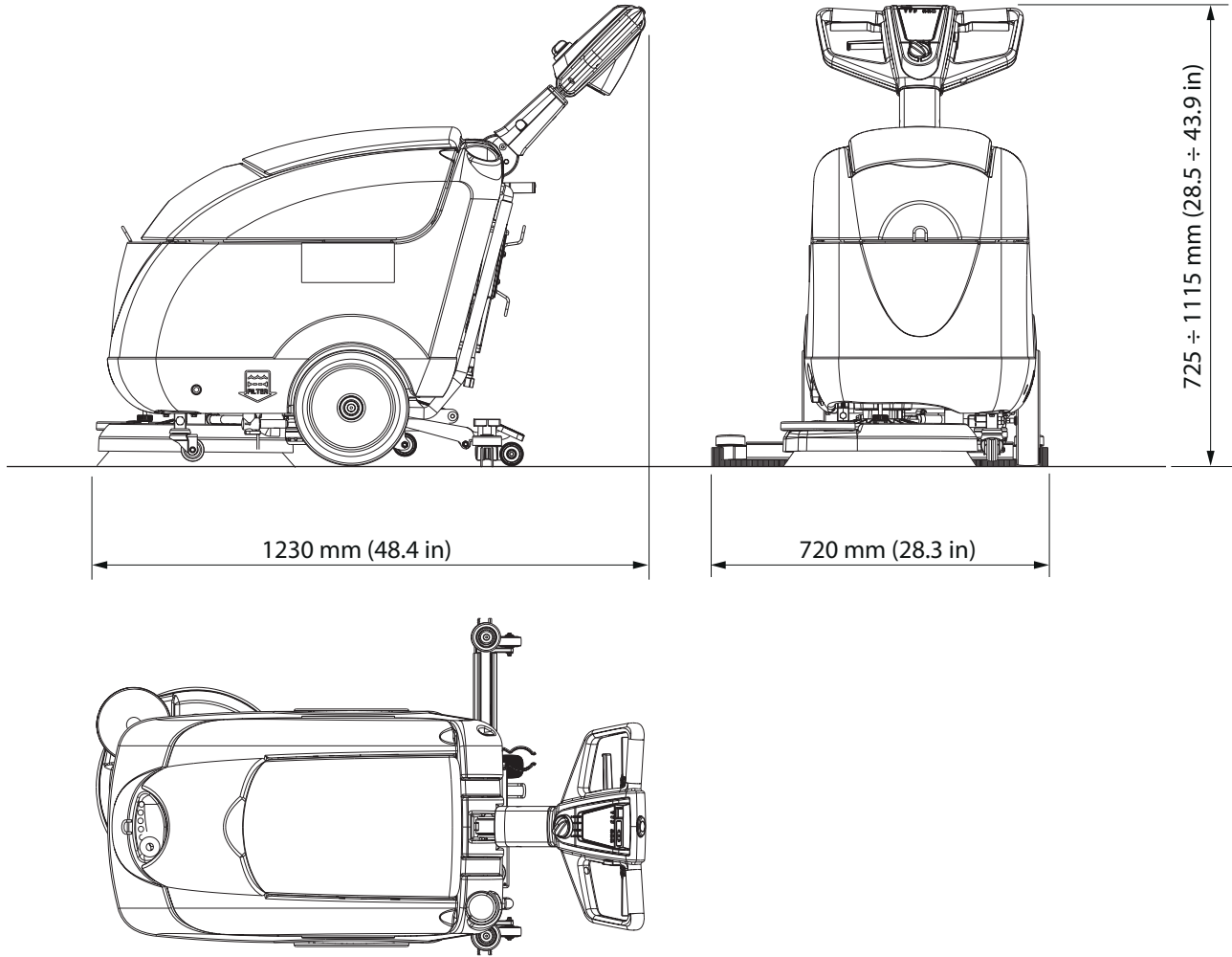

P200074

## Maintenance

The lifespan of the machine and its maximum operating safety are ensured by correct and regular maintenance.



**Warning!** *Read carefully the instructions in the Safety chapter before performing any maintenance procedure.*

The following table provides the scheduled maintenance. The intervals shown may vary according to particular working conditions, which are to be defined by the person in charge of the maintenance.

For instructions on maintenance procedures, see the following paragraphs.

### Scheduled Maintenance Table

Procedure	Daily, after using the machine	Weekly	Every six months	Yearly
Squeegee Cleaning				
Brush Cleaning				
Tank and Vacuum Grid Cleaning				
Squeegee Blade Check and Replacement				
Solution Filter Cleaning				
Battery Charging				
WET battery fluid level check				
Screw and nut tightening check			(1)	
Brush motor carbon brush check and replacement				
Vacuum system motor carbon brush check and replacement				

(1) And after the first 8 working hours.

# Control System

## Functional Description

The function control is performed with the program selection knob/rotary switch (SW1), the machine start-up enabling push button (SW2) (which can be used simultaneously with the brush levers) and the solution flow push-button (SW3).

The switch outputs are read by the function electronic board (EB1) which consequently controls the relevant outputs: electromagnetic switch (K1) for brush motor, relay (K2) for vacuum system motor, while the solenoid valve (EV1) is activated directly from the electronic board.

The control circuits are protected by the fuse (F3) on the function electronic board (EB1).

The LED electronic board (EBLED) has a set of 3 two-color LEDs. The set of 3 LEDs is used to indicate either battery charge level or water flow level depending on the current mode of operation:

LEDs to display the battery charge level		
LEDs to set water flow level		

The LED electronic board (EBLED) is driven by the function electronic board (EB1).

## Diagram of Output Activation according to the Position of the Switches (SW1), (SW2) and (SW3)

Program selection knob /rotary switch (SW1) settings	Machine start-up enabling push button (SW2) settings (with brush levers)	Function electronic board (EB1) + LED electronic board (EBLED)	Brush motor (M1) + solenoid valve (EV1)	Vacuum system motor (M2)
	Pressed/released	Off	Off	Off
	Released	On	Off	On
	Pressed	On	On	On
	Released	On	Off	Off
	Pressed	On	On	Off
	Pressed/released	On	Off	On

Solution flow push-button setting (SW3)	LED display	Symbols	Solenoid valve ON time (EV1)	Solenoid valve OFF time (EV1)
0			-	Always OFF
1			1 sec	5 sec
2			3 sec	3 sec
3			Always ON	-

# Wiring Diagram

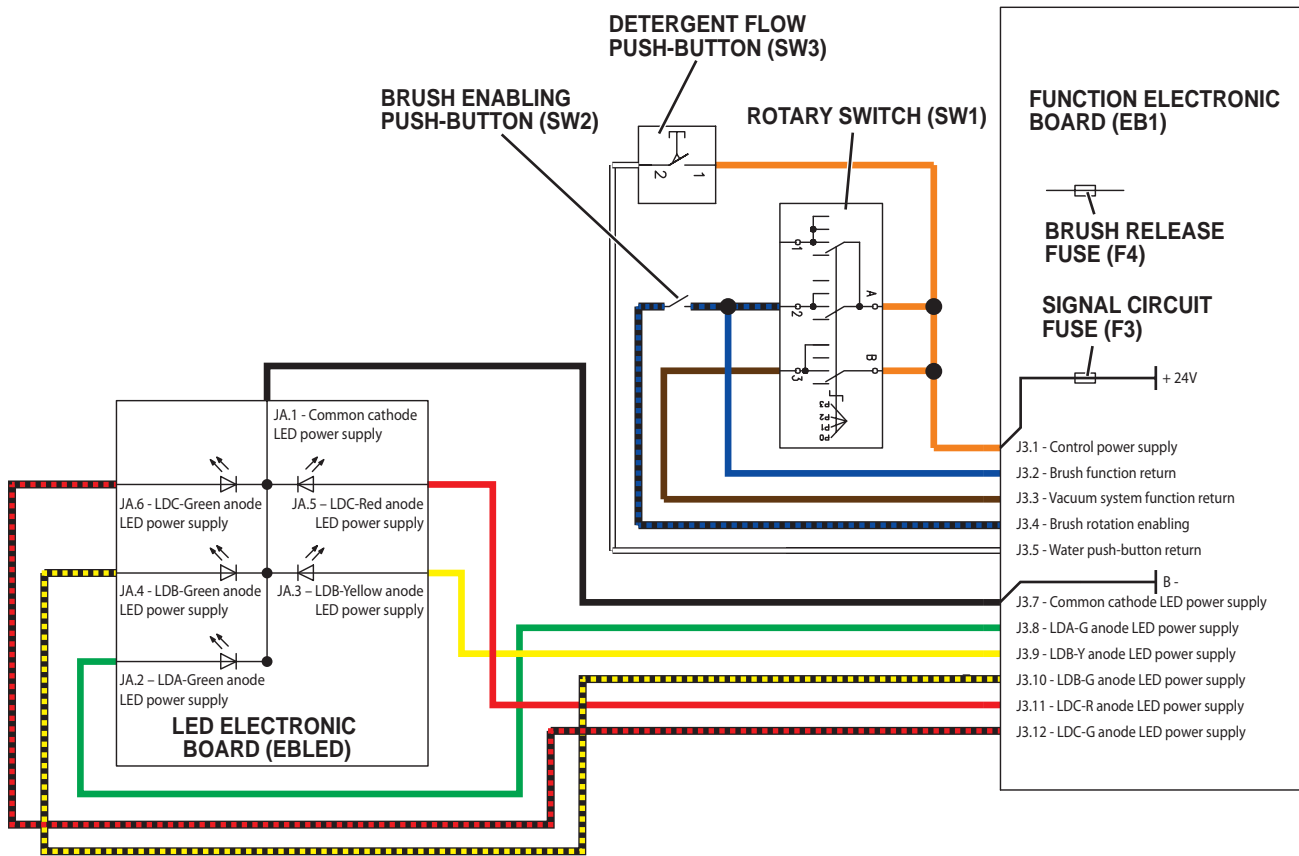

## Component Locations

- Handlebar with control panel
- Program selection knob / rotary switch (SW1)
- LED indicators for:
  - solution quantity
  - battery charge
- Rotary switch (SW1)
- Brush levers
- Machine start-up enabling push button (SW2)
- Solution flow push-button (SW3)
- Function electronic board (EB1)
- LED electronic board (EBLED)
- Low consumption circuit fuse (F3)
- Wiring harness
- Handlebar inclination adjusting lever

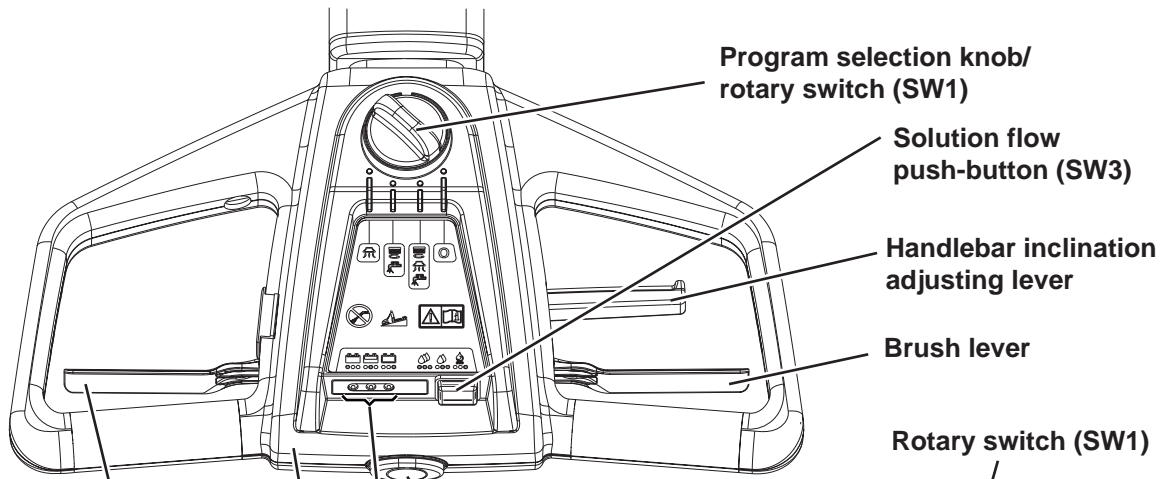

Brush lever

Handlebar with control panel

LED indicators for:  
- solution quantity  
- battery charge

Machine start-up enabling push button (SW2)

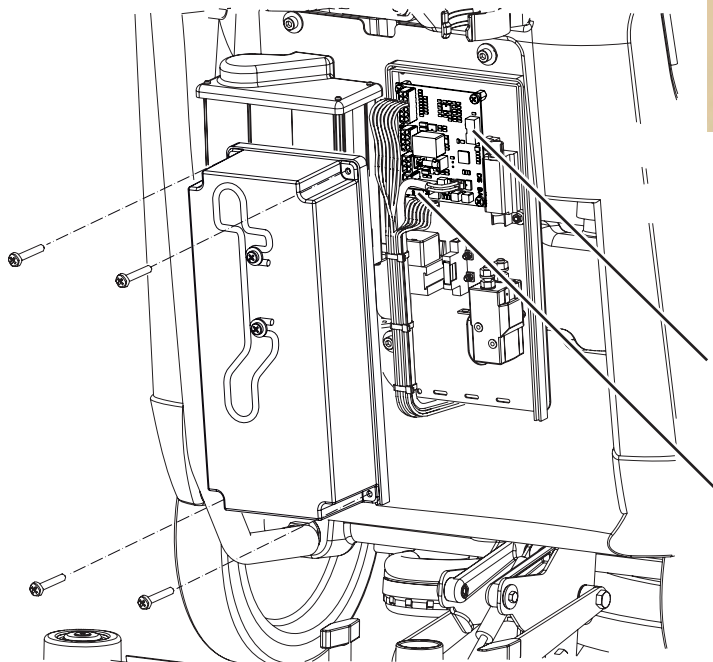
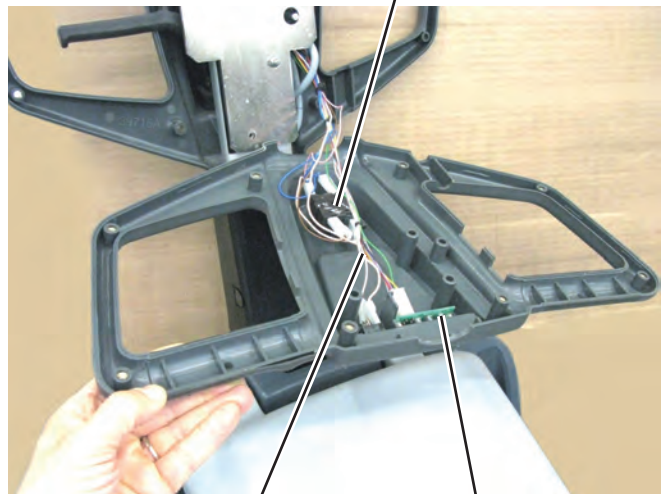

Function electronic board (EB1)

Low consumption circuit fuse (F3)

## Removal and Installation

### Function Electronic Board (EB1) Disassembly/Assembly

#### Disassembly

1. Drive the machine on a level floor. Make sure that the machine cannot move independently.
2. Turn the machine program selection knob to “0”.
3. Disconnect the battery connector (red).
4. Disconnect the battery charger cable from the holder (A).
5. Remove the screws (B) and remove the cover (C).
6. Disconnect the connectors (D) of the function electronic board (E).
7. Remove the screws (F) and remove the function electronic board (E).

#### Assembly

8. Assemble the components in the reverse order of disassembly, and note the following:
  - Set the DIP-switches (G) according to the machine fitting as shown below.

Fitting	DIP-switch	DIP-switch position
WET batteries	DIP 1	WET (ON)
GEL-AGM batteries		GEL (OFF)
Battery charger installed (standard)	DIP 2	CH (OFF)
Battery charger not installed		NO CH (ON)



*Note: The battery charger is installed on the machine as a standard component; the dip-switch must be turned to OFF (CH position)*

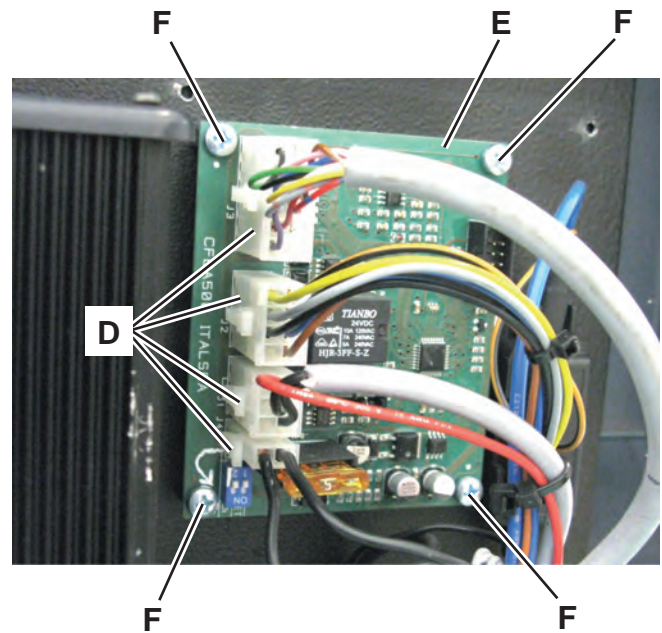
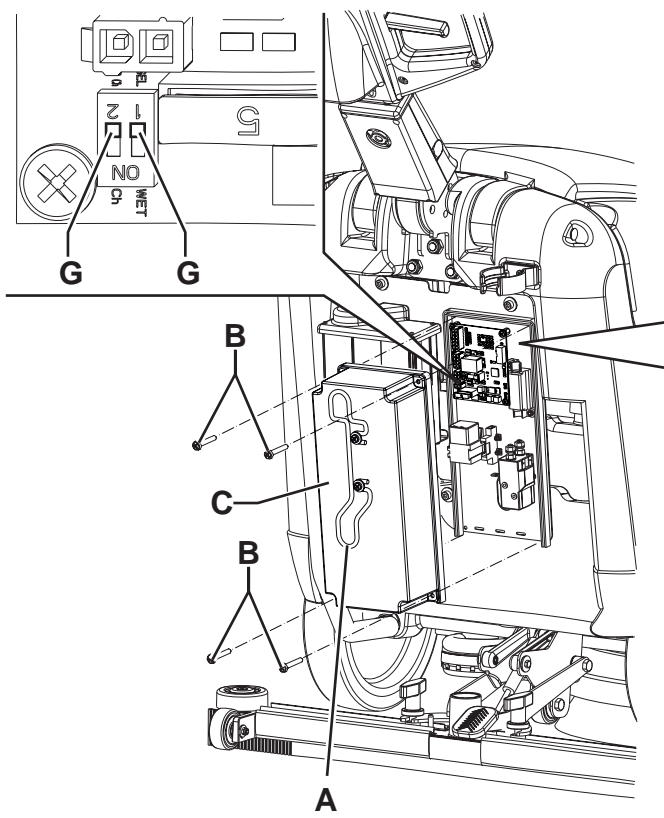

## LED Electronic Board (EBLED) Disassembly/Assembly

### Disassembly

1. Drive the machine on a level floor. Make sure that the machine cannot move independently.
2. Turn the machine program selection knob to “0”.
3. Disconnect the battery connector (red).
4. On the lower side of the handlebar with the control panel, unscrew the screws (A).
5. Lower the upper side (B) of the handlebar with the control panel.
6. Disconnect the connector (C) of the LED electronic board (D). Remove the screws (E) and remove the LED electronic board (D).
7. If necessary, disconnect the connector (F) and remove the solution flow push-button (G) by disengaging the inner tabs (H).

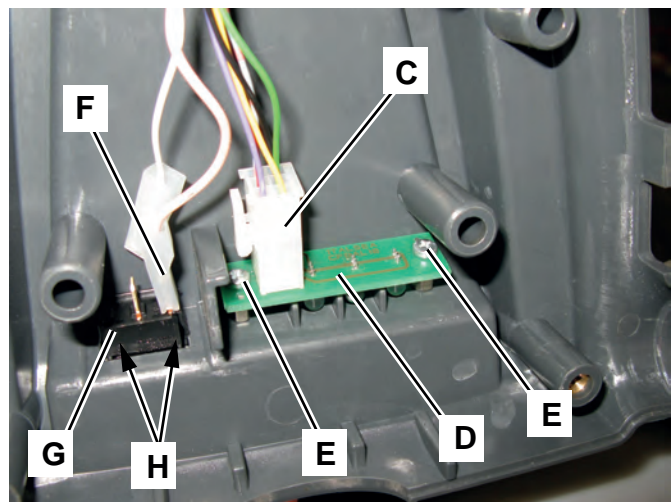
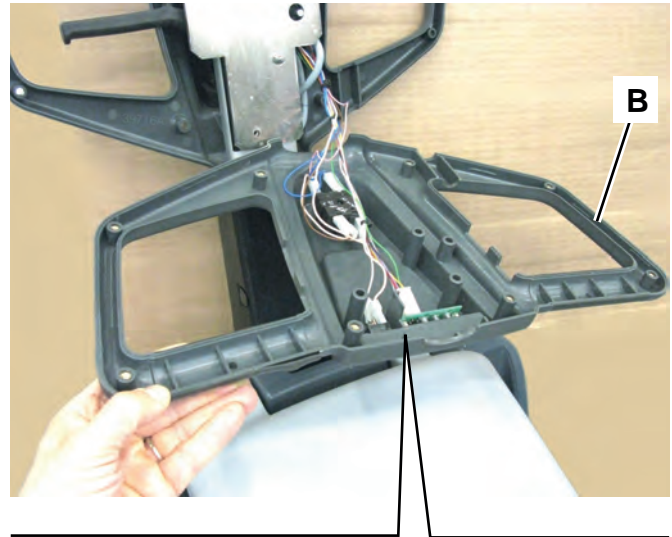
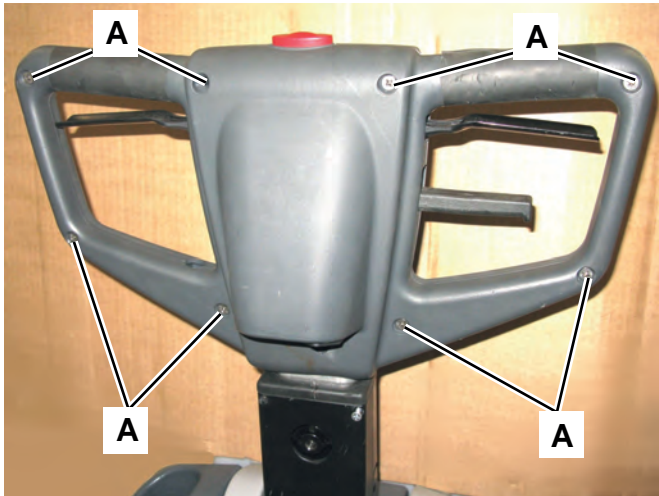

### LED Electronic Board (EBLED) Disassembly/Assembly (Continues)

8. If necessary, remove the selector assembly (N) of the machine program selection knob (I), as shown below:
- Disconnect the connectors (J)
  - On the outer side, turn the knob (I) on the position (K) (vacuum system activation).
  - Loosen the set screw inside the housing (L), then remove the knob (I) from the housing.
  - Remove the screws (M) and, from the inside, remove the selector assembly (N) of the knob (I).

#### Assembly

9. Assemble the components in the reverse order of disassembly.

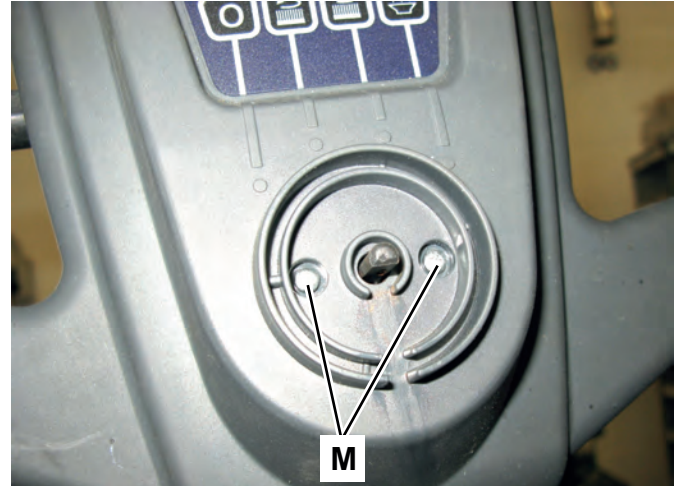
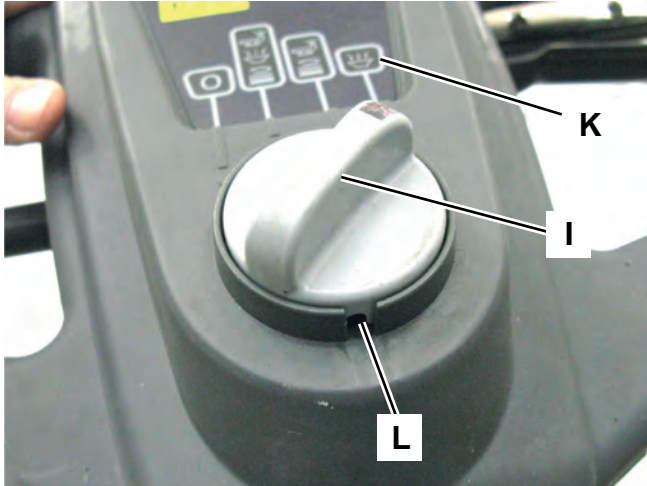
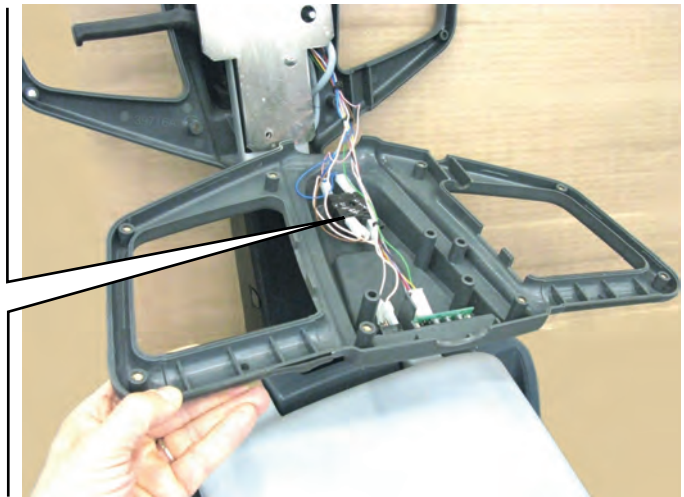
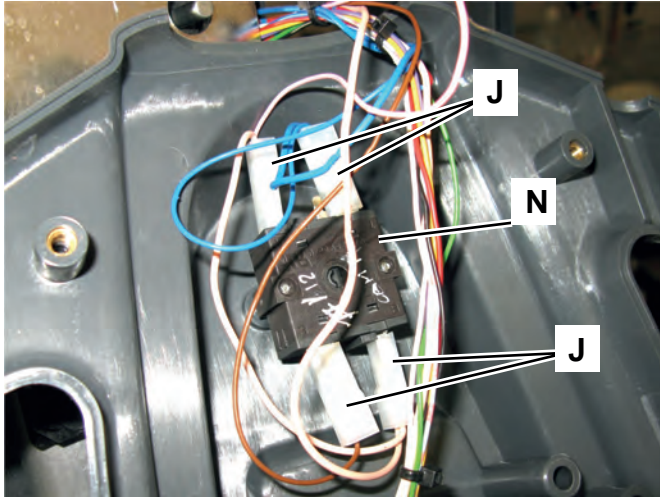

## Machine Start-up Enabling Push-Button Disassembly/Assembly (SW2)

### Disassembly

1. Drive the machine on a level floor. Make sure that the machine cannot move independently.
2. Turn the machine program selection knob to “0”.
3. Disconnect the battery connector (red).
4. On the lower side of the handlebar with the control panel, unscrew the screws (A).
5. Move the upper side (B) of the handlebar with the control panel.
6. Remove the screws (C) and move the lower side (D) of the handlebar from the frame (E).
7. Disconnect the connectors (F) of the brush enabling push-button (G).
8. Remove the screws (H) and remove the switch (G).
9. If necessary, remove from the housing the enabling push-button (I) of the switch (G).
10. If necessary, remove the brush levers (J) from the housing.

### Assembly

11. Assemble the components in the reverse order of disassembly.

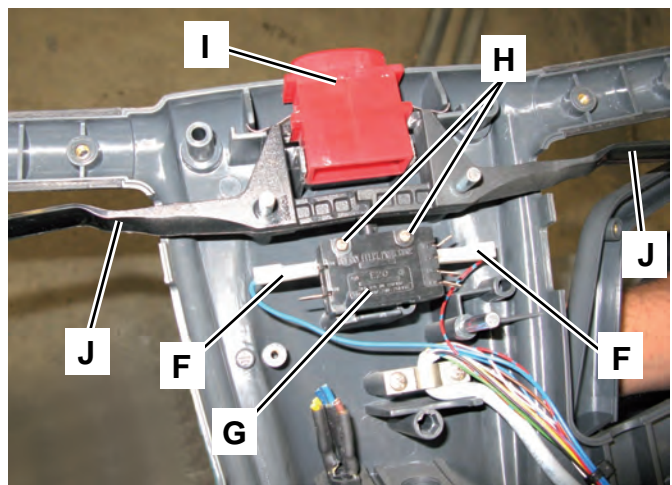
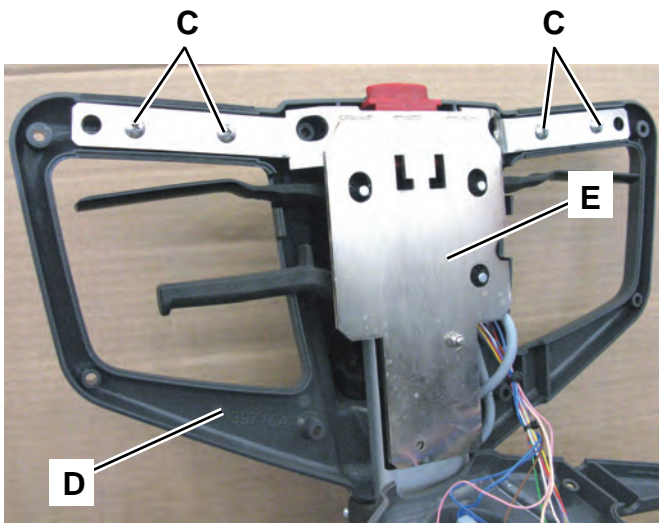
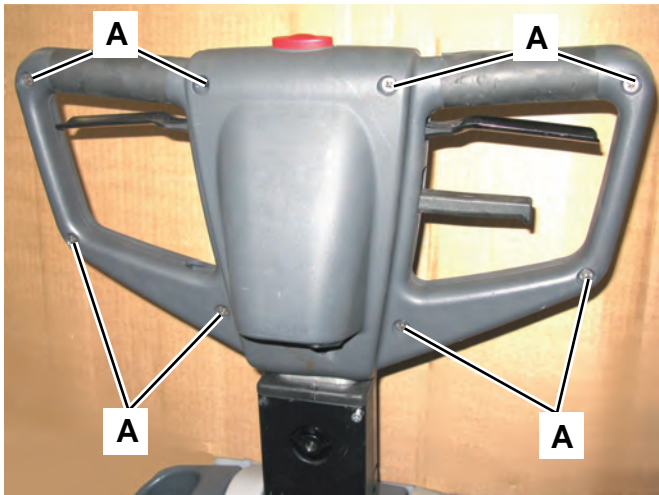

# Specifications

## Function Electronic Board (EB1) Specifications

### FUSES

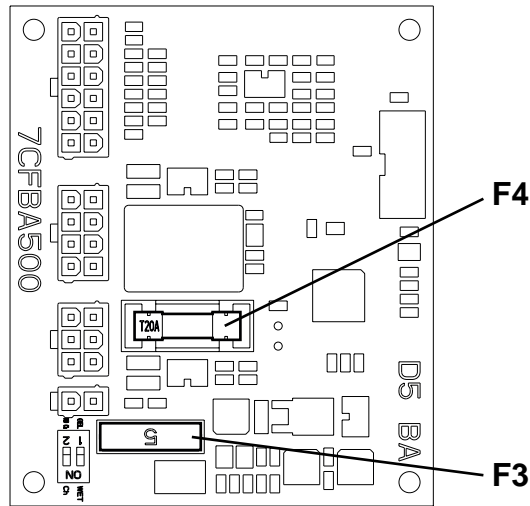

Code	Description	Type	Size
F3	Low consumption circuit fuse	LITTELFUSE ATOFUSE	5A
F4	Brush release circuit fuse	OMEGA CT520320	20A

### DIP-SWITCHES

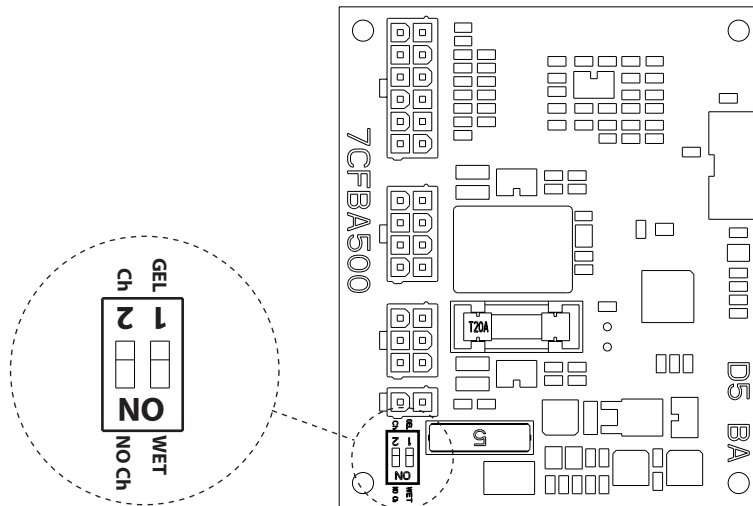

Code	Description
DIP1	WET/GEL selector
DIP2	Battery charger enabling

## Function Electronic Board (EB1) Connectors

**J1: MOLEX MINIFIT type, 6-ways vertical**

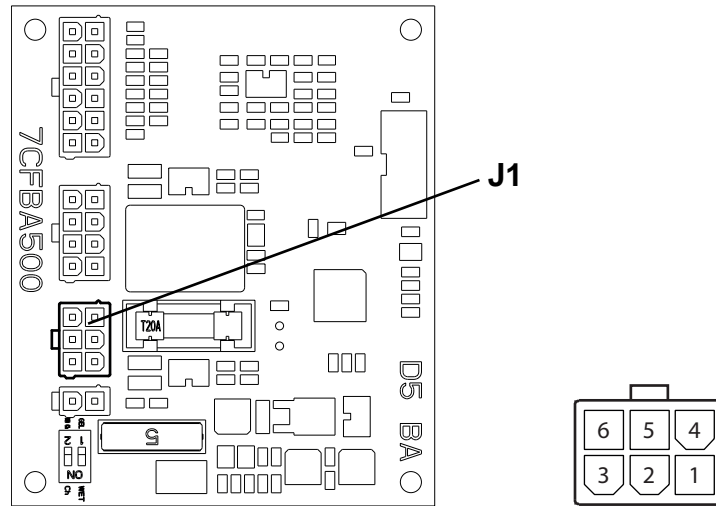

PIN	Description	Electronic board in/out	V ref.	I max.	Connected to
1	Electronic board power supply +	in	24V	5A	BAT
2	Solenoid valve power supply +	out	24V	1A	EV1
3	Solenoid valve power supply -	out	0V	1A	EV1
4	Not used				
5	Not used				
6	Not used				

## Function Electronic Board (EB1) Connectors (Continues)

### J2: MOLEX MINIFIT type, 8-ways vertical

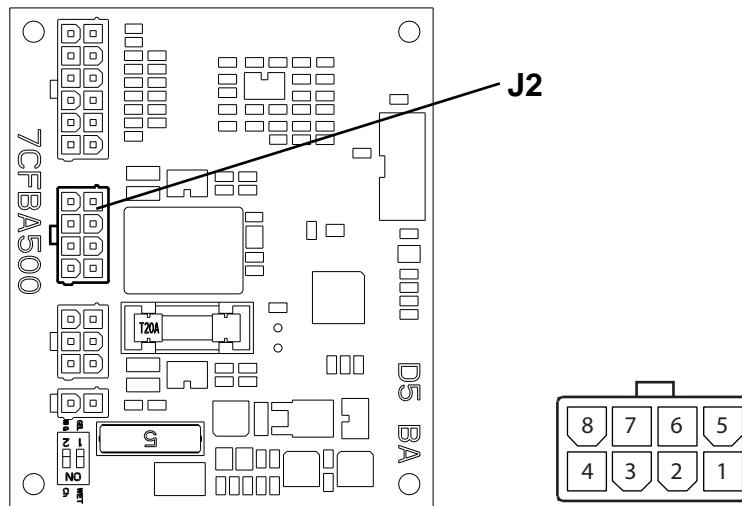

PIN	Description	Electronic board in/out	V ref.	I max.	Connected to
1	Brush fuse voltage drop reading +	in	0V	<1A	F1
2	Brush fuse voltage drop reading -	in	0V	<1A	F1
3	Brush electromagnetic switch power supply -	out	0V	1A	ES1
4	Vacuum system relay power supply -	out	0V	1A	ES2
5	Electromagnetic switch/relay power supply +	out	24V	2A	ES1-ES2
6	Brush motor braking circuit	in	24V	100A imp. 0A cont.	ES1.NC
7	Electronic board power supply -	in	0V	5A	BAT
8	Not used				

### Function Electronic Board (EB1) Connectors (Continues)

#### J3: MOLEX MINIFIT type, 12-ways vertical

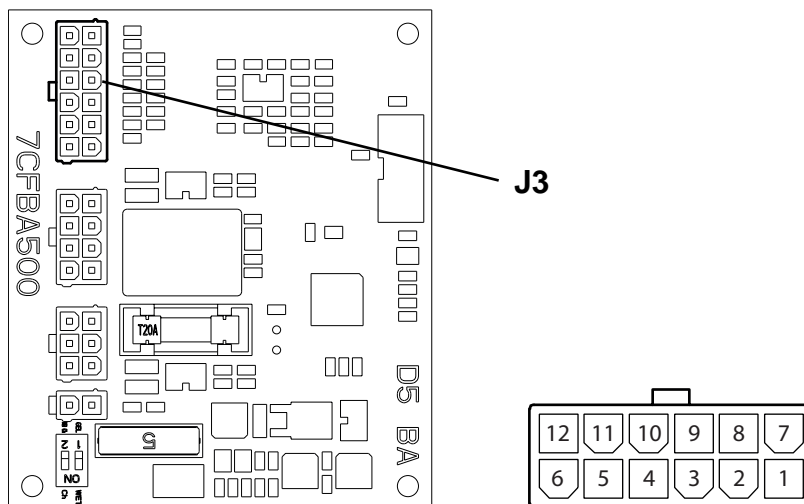

PIN	Description	Electronic board in/out	V ref.	I max.	Connected to
1	Control power supply	out	24V	<1A	SW1 - 2 - 3
2	Brush function return	in	24V	<1A	SW1
3	Vacuum system function return	in	24V	<1A	SW1
4	Brush rotation enabling	in	24V	<1A	SW2
5	Water push-button return	in	24V	<1A	SW3
6	Not used				
7	Common cathode LED power supply	out	0V	<1A	JA.1
8	LDA-G anode LED power supply	out	0.7V	<1A	JA.2
9	LDB-Y anode LED power supply	out	0.7V	<1A	JA.3
10	LDB-G anode LED power supply	out	0.7V	<1A	JA.4
11	LDC-R anode LED power supply	out	0.7V	<1A	JA.5
12	LDC-G anode LED power supply	out	0.7V	<1A	JA.6

### Function Electronic Board (EB1) Connectors (Continues)

**J4: MOLEX MINIFIT type, 2-ways vertical**

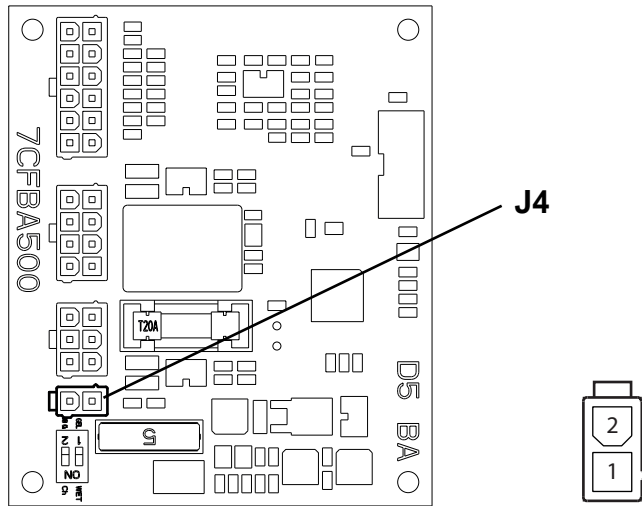

PIN	Description	Electronic board in/out	V ref.	I max.	Connected to
1	Battery charger enabling power supply	out	24V	5A	CH.1
2	Battery charger enabling return	in	24V	5A	CH.2

### LED ELECTRONIC BOARD CONNECTOR (EBLED B side)

**JA: MOLEX MINIFIT type, 6-ways vertical**

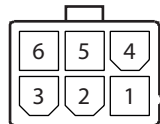

PIN	Description	Electronic board in/out	V ref.	I max.	Connected to
1	Common cathode LED power supply	in	0V	<1A	J3.7
2	LDA-Green anode LED power supply	in	0.7V	<1A	J3.8
3	LDB-Yellow anode LED power supply	in	0.7V	<1A	J3.9
4	LDB-Green anode LED power supply	in	0.7V	<1A	J3.10
5	LDC-Red anode LED power supply	in	0.7V	<1A	J3.11
6	LDC-Green anode LED power supply	in	0.7V	<1A	J3.12

### LED Electronic Board (EBLED) Specifications

Code	Description
LDA	GREEN / RED two-color Ø5mm LED
LDB	GREEN / YELLOW two-color Ø5mm LED
LDC	GREEN / RED two-color Ø5mm LED

## Controls and Functions

- a. Low consumption circuit fuse (F3): directly downstream of J1.1, it protects all the inner and outer circuits supplied by the electronic board.
- b. Battery charger enabling circuit power supply (J4.1): directly downstream of F3.
- c. BATTERY CHARGER enabling (J4.2): if the dip-switch DIP2 is turned to 0 (CH position), the electronic board functions are activated only when the on-board battery charger is NOT connected to the electrical mains; if DIP2 is turned to 1 (NO CH position), the electronic board functions are active whether or not the battery charger is on board.  
**THE BATTERY CHARGER IS INSTALLED ON THE MACHINE AS A STANDARD COMPONENT; the dip-switch MUST BE turned to 0 (CH position).**
- d. BRUSH function: is activated when J3.2 is at 24V with a 1 sec.-delay at switching off.  
 The BRUSH function includes activation of J2.3 (BRUSH ELECTROMAGNETIC SWITCH) and J1.2,3 (SOLENOID VALVE) outputs, which are subjected to the presence of the signal on J3.4 with a 1 sec.-delay to switching on. The output on J1.2,3 (SOLENOID VALVE) is controlled by the WATER FLOW CONTROL function (see step f).  
 The BRUSH function is subjected to the BATTERY PROTECTION function (see step g) and to the BRUSH MOTOR PROTECTION function (see step j).
- e. VACUUM SYSTEM function: is activated when J3.3 is at 24V with a 1 sec.-delay at switching on and a 1 sec.-delay at switching off.  
 The VACUUM SYSTEM function includes the activation of J2.4 (VACUUM SYSTEM RELAY) output.  
 The VACUUM SYSTEM function is subjected to the BATTERY PROTECTION function (see step g).
- f. WATER FLOW CONTROL function: J1.2,3 (SOLENOID VALVE) output, when activated (see step d), is modulated by ON/OFF cycles according to the following table; the current status is shown by the LEDs (see step h):

Solution flow push-button setting (SW3)	LED display	Solenoid valve ON time (EV1)	Solenoid valve OFF time (EV1)
0	○ ○ ○	-	Always OFF
1	○ ○ ●	1 sec	5 sec
2	○ ● ●	3 sec	3 sec
3	● ● ●	Always ON	-

The default setting for the solution flow push-button (SW3) is 1.

The next detergent percentage setting is NOT stored into memory when the machine is turned off.

## Controls and Functions (Continues)

- g. BATTERY PROTECTION function: battery charge status is shown by the 3 LEDs depending on the type of battery (WET/GEL, see step j) according to the following diagram:

Transition threshold (V, tolerance $\pm 0.1$ )		WET	GEL
1	Green (fix) <=> yellow (fix)	22.0	22.2
2	Yellow (fix) => red (flashing 1Hz)	20.4	21.6
3	Safety threshold	19.4	20.6

The transition is filtered with a time constant of 3 sec. as to the supply voltage reading.

When threshold 2 is reached, the J2.3 (BRUSH ELECTROMAGNETIC SWITCH) and J1.2,3 (SOLENOID VALVE) outputs are automatically cut off after a 5 sec.-delay.

In chase threshold 3 is reached, also J2.4 (VACUUM SYSTEM) output is automatically deactivated (without delays) and the BRUSH MOTOR BRAKING function (see step k) is disabled.

Irrespective of the voltage reading, when transition 2 is performed, it is not possible to go back to YELLOW or GREEN condition.

The system reset happens when the machine is turned off by turning the rotary switch (SW1) to 0.

- h. WATER FLOW SETTING function: When the battery charge status is above threshold 1, the 3 LEDs show the charge status only during the first 5 sec. after BRUSH or VACUUM SYSTEM function has been activated, then they switch to the display of water flow setting (see step f). If during the first 5 sec. the push-button SW3 is pressed, the display immediately switches to the water flow setting. When the water flow setting is displayed, each time the push-button SW3 is pressed, the setting of the water flow increases by 1 in sequence (from 3 to 0). When the battery charge status is below threshold 1, the display shows the battery charge status. The LEDs switches from battery charge status to water flow setting display, only when the push-button SW3 is pressed. This display last 5 sec., before switching again. If during the 5 sec. the push-button SW3 is pressed, the setting of the water flow increases by 1 in sequence (from x=3 to x=0). If the push-button SW3 is not pressed for more than 5 sec., the display switches again to the battery charge status.
- i. Battery type selection (WET/GEL): each time the electronic board is switched on, the current condition is shown for 2 sec. by LEDs according to the following diagram:

WET	RED LED flashing
GEL	GREEN LED flashing

After the first 2 sec., the LEDs show the battery charge status or the water flow level (see step h).

WET/GEL setting depends from dip-switch DIP1 position, according to the silk-screen printed “WET” and “GEL” marks beside the dip-switch.

## Controls and Functions (Continues)

- j. BRUSH MOTOR PROTECTION function: through the differential input (J2.1 - J2.2), the voltage drop is read on the BRUSH MOTOR fuse: if the voltage drop exceeds the alarm threshold for more than 30 sec., the J2.3 (BRUSH ELECTROMAGNETIC SWITCH) and J1.2,3 (SOLENOID VALVE) outputs are switched off until their reset by switching off the electronic board.

When the threshold is exceeded (without delays), the GREEN, YELLOW and RED LEDs flash simultaneously (freq. 1Hz).

The alarm threshold is  $40 \pm 2$ mV, which correspond to about  $40 \pm 5$  Ampere in the motor.

If the protection activates (automatic switching off of J2.3 and J1.2,3 outputs), the GREEN, YELLOW and RED LEDs continue to flash until their reset by switching off the machine.

- k. BRUSH REMOVAL SYSTEM: When the BRUSH function is active and the push-button SW2 is NOT PRESSED for at least 3 sec., if the push-button SW2 is pressed and released 3 times in 2 sec., the following cycle is performed:

- 1) Alternating flashing of RED AND GREEN LEDs for 2 sec. to confirm brush remove mode.
- 2) Closing (by a TIANBO HJR-3FF-S-Z relay contact) of J2.6 output on J1.1 positive power supply through F4 fuse, for 2 sec. shunt B+ to both states of motor to cause abrupt stop.
- 3) Activation after 0,2 sec. of J2.3 (BRUSH ELECTROMAGNETIC SWITCH) output for 1 sec..

The BRUSH REMOVAL SYSTEM is subjected to the BATTERY PROTECTION function (see step g).

During this cycle (which lasts 4 sec.) the SW2 push-button is disabled.

# Electrical System

## Functional Description

Basically the electrical system consists of a function electronic board (EB1) which determines the brush motor, vacuum system motor and solenoid valve activation by means of the relevant controls (rotary switch (SW1) and brush activation push-button (SW2)), disabling them when the battery voltage drops below the battery safety threshold value.

The batteries are connected to the system by means of the ANDERSON POWER connector (C1).

The battery charger (CH) is connected to the batteries (BAT) directly on the – and + terminals and it supplies the enabling signal to activate the machine functions only when it is disconnected from the electrical mains with the J4 2-way connector. When the battery charger is connected to the electrical mains, the battery charger inner relay opens the contact and stops the enabling signal on the J4 connector.

For further details, see the descriptions of individual sub-systems.

## Fuses

The brush motor circuit is protected from short-circuits by the 40A fuse (F1). The motor is protected from overloads by means of the electronic protection system described in the Function Electronic Board Specifications chapter.

The vacuum system motor circuit is protected by the 30A fuse (F2).

The solenoid valve (EV1) and the function electronic board (EB1) control circuits are protected by the 5A fuse (F3) on the function electronic board (EB1).

The brush release circuit is protected by the 20A fuse (F4) on the function electronic board (EB1).

(Only for 9087311020 - 9087318020 models). The 125A battery fuse (F0) is assembled directly on the + terminal of the battery and jump connected to the negative terminal of the other. This fuse operates only in case of short circuits on the machine power wiring harness, to prevent fire or battery explosion.

## Wiring Diagram

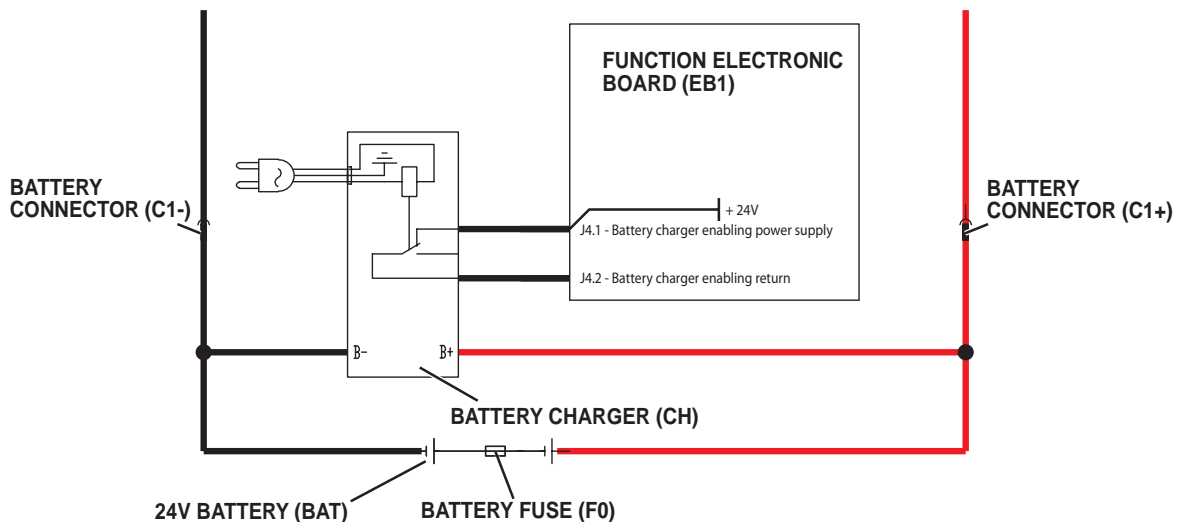

## Component Locations

- Battery charger (CH)
- Batteries (BAT)
- Battery connection connector (C1)
- Battery wiring harness
- Machine wiring harness
- Electrical component box
- Battery fuse (F0) (only for 9087311020 – 9087318020 models)
- Brush motor fuse (F1)
- Vacuum system motor fuse (F2)
- Solenoid valve and electronic board fuse (F3)
- Brush release fuse (F4)

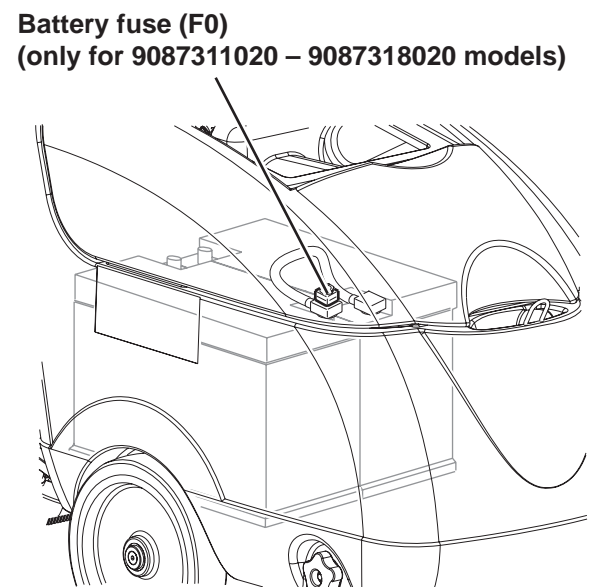
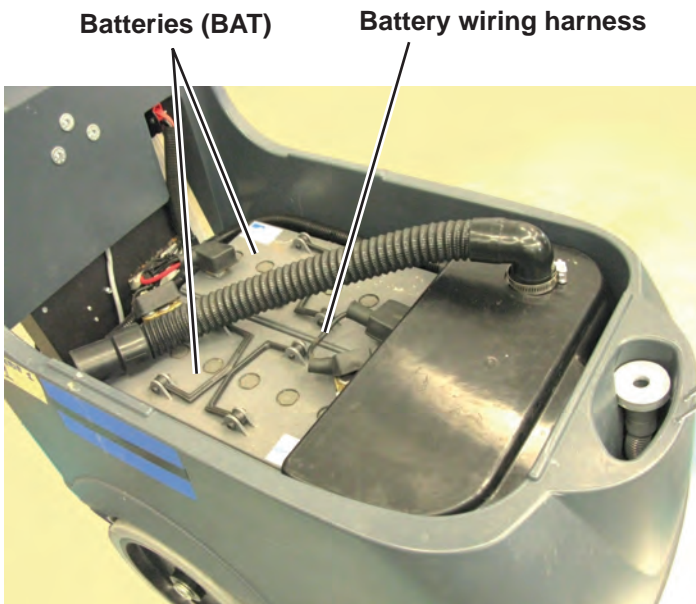
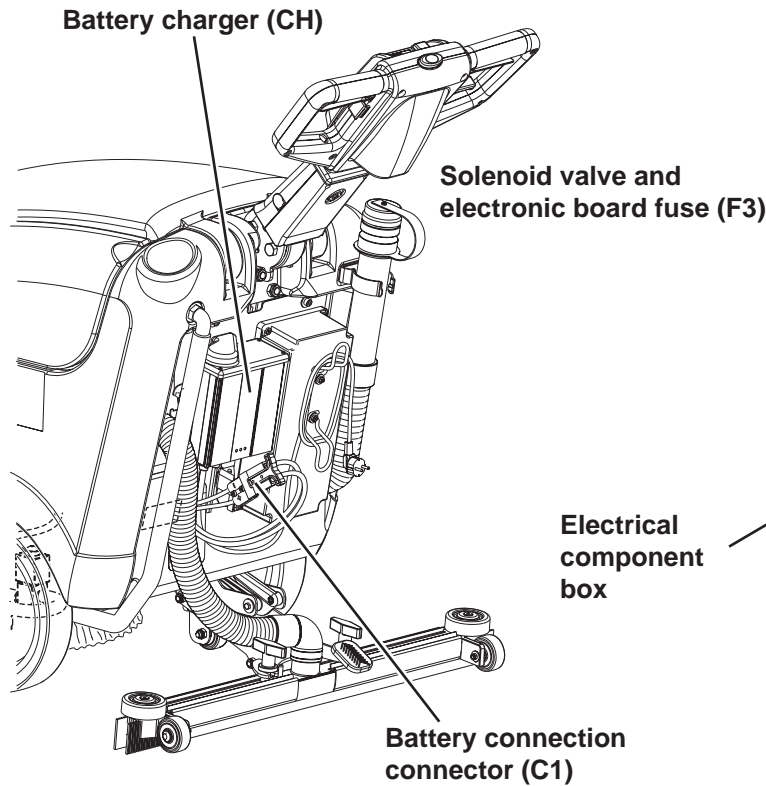

## Maintenance and Adjustments

### Battery Installation And Battery Type Setting (WET or GEL/AGM)

Set the electronic board of the machine and the battery charger according to the type of batteries to be installed (WET or GEL/AGM) as shown below.

#### Machine Setting

1. Disconnect the battery connector (red).
2. Remove the screws (A), then carefully remove the electrical component box cover (B).
3. On the electronic board, turn the microswitch (C) to WET or GEL/AGM, according to the type of batteries to be installed.



**Warning!** Do not move/set the adjacent switch (D).

4. Reinstall the electric component box cover (B) and tighten the screws (A).

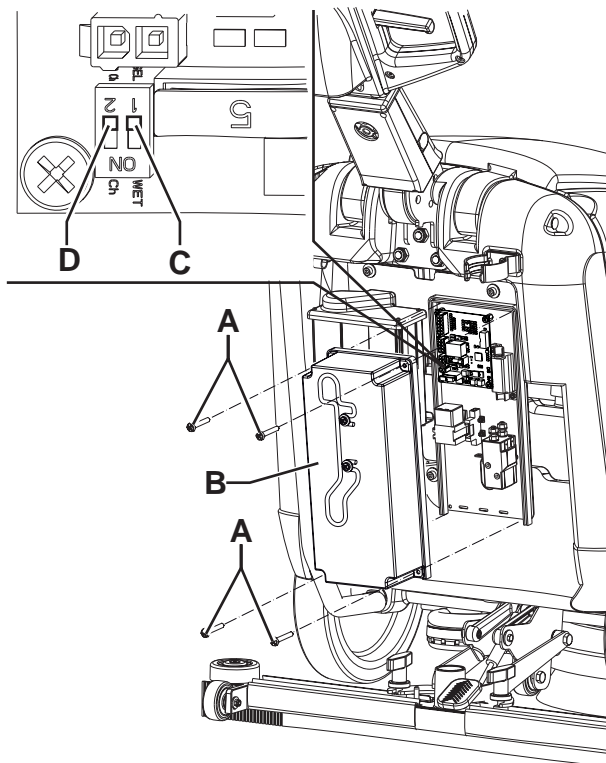

## Battery Installation And Battery Type Setting (WET or GEL/AGM) (Continues)

### Battery charger setting

- To set the battery charger, refer to the relevant Manual supplied with the machine.

### Battery Installation

- Disconnect the vacuum hose (E) from the squeegee (F).
- Disconnect the recovery water drain hose (G) from the bracket (H).
- Open the cover (I).
- Grasp the recovery tank (J) in the area (K) and slightly raise it.
- Disconnect the vacuum hose (L) from the tank, then remove the tank (J) with the hoses (M) and (N).
- Install the batteries on the machine according to the diagram (P).
- Perform steps 6 to 10 in the reverse order.
- Connect the battery connector (red).
- Charge the batteries (see the procedure in Battery Charging paragraph).

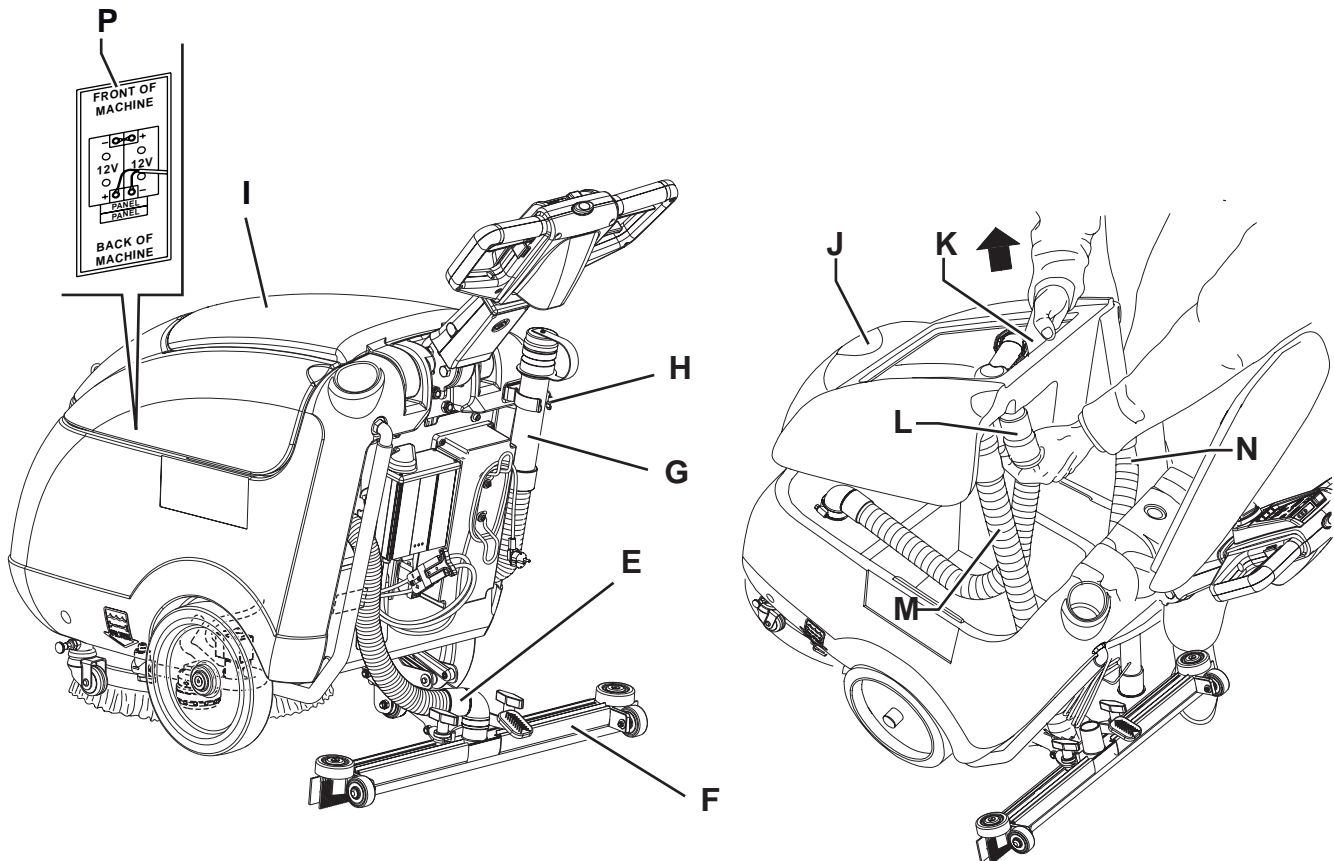

## Battery Charging



**Note:** Charge the batteries when the yellow or red LED turns on, or at the end of each working cycle. Keeping the batteries charged make their life last longer.



**Caution!** When the batteries are discharged, charge them as soon as possible, as that condition makes their life shorter. Check for battery charge at least once a week.



**Caution!** When using lead (WET) batteries, battery charging produces highly explosive hydrogen gas. Charge the batteries in well-ventilated areas and away from naked flames.

**Do not smoke while charging the batteries.**

**Do not reinstall the recovery tank until the battery charging cycle is over.**



**Caution!** Pay careful attention when charging lead batteries (WET) as there may be battery fluid leakages. The battery fluid is corrosive. If it comes in contact with skin or eyes, rinse thoroughly with water and consult a physician.

1. Drive the machine to the appointed recharging area.
2. Turn the machine program selection knob to “0”.
3. For WET batteries only:
  - Tip up the recovery tank.
  - Check the level of electrolyte inside the batteries; if necessary, top up through the caps.
  - Leave all the battery caps open for next charging.
  - If necessary, clean the upper surface of the batteries.
4. Connect the battery charger cable to the electrical mains (the electrical mains voltage and frequency must be compatible with the battery charger values shown on the machine serial number plate).



**Note:** When the battery charger is connected to the electrical mains, all machine functions are automatically cut off.  
The battery charger red or yellow LED turned on, indicates that the batteries are charging.

5. When the battery charger green LED stays on, the battery charging cycle is over.
6. When the battery charging is completed, disconnect the battery charger cable from the electrical mains and wind it round its housing.
7. For WET batteries only:
  - Close all the battery caps.
  - Tip down the recovery tank.
8. Now the machine is ready to be used.



**Note:** For further information about the operation of the battery charger, see the Battery Charger Manual.

## Fuse Check and Replacement

### Fuses in the electric component box

1. Drive the machine on a level floor. Make sure that the machine cannot move independently.
2. Disconnect the battery connector (red).
3. Remove the screws (A), then remove the electrical component box cover (B).
4. Check the following fuses for integrity:
  - (C): F1 (40 A) circuit breaker, brush motor (open cover).
  - (D): F2 (30 A) blade fuse, vacuum system motor.
  - (E): F3 (5 A) blade fuse, solenoid valve and electronic board.
  - (F): F4 (20 A) glass fuse, brush release system.
5. Replace the open fuse, when the component that caused deactivation has fully cooled down.
6. Place the cover (B) and tighten screws.
7. Connect the battery connector (red).

### Battery Fuse (only for 9087311020 – 9087318020 models)

1. Drive the machine on a level floor. Make sure that the machine cannot move independently.
2. Disconnect the battery connector (red).
3. Remove the recovery tank.
4. On the battery cable (G) check/replace the following fuse:
  - (H): F0 (125 A) battery fuse.
5. Assemble the recovery tank.
6. Connect the battery connector (red).

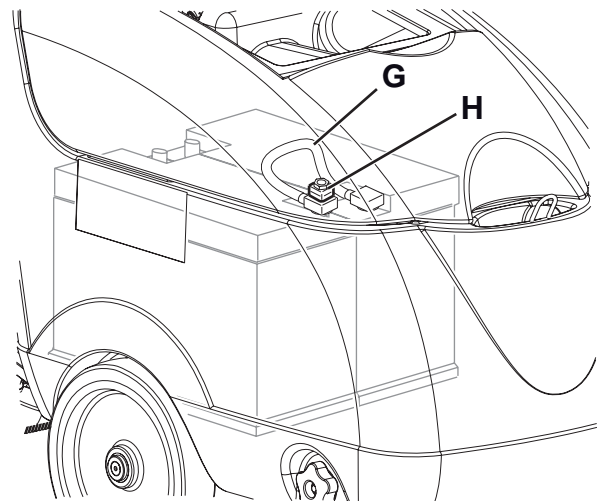
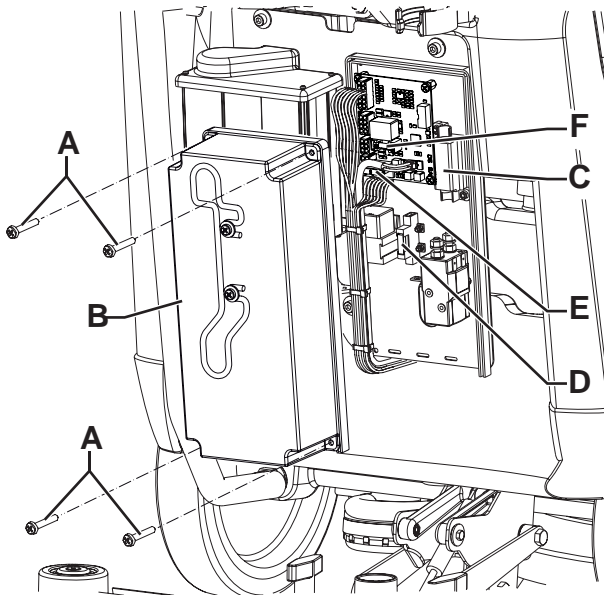

## Troubleshooting

Trouble	Possible Causes	Remedy
The machine is not working	The battery connector (C1) is not connected or broken	Connect or replace it
	The batteries (BAT) are discharged or its connections are not efficient	Charge the batteries or clean/repair the connections
	The batteries (BAT) are broken	Check the battery no-load voltage
	The battery charger (CH) is broken	Replace
	The fuses (F0, F3) are open	Replace
	The wiring harness is cut or pressed or short circuited	Repair
	The rotary switch (SW1) of the program selection knob is not working	Replace
	The function electronic board (EB1) is broken	Replace
	The DIP-switch 2 is turned to NO CH (ON) when the battery charger is installed	Turn the DIP-switch 2 to CH (OFF)

### Machine Wiring Diagram

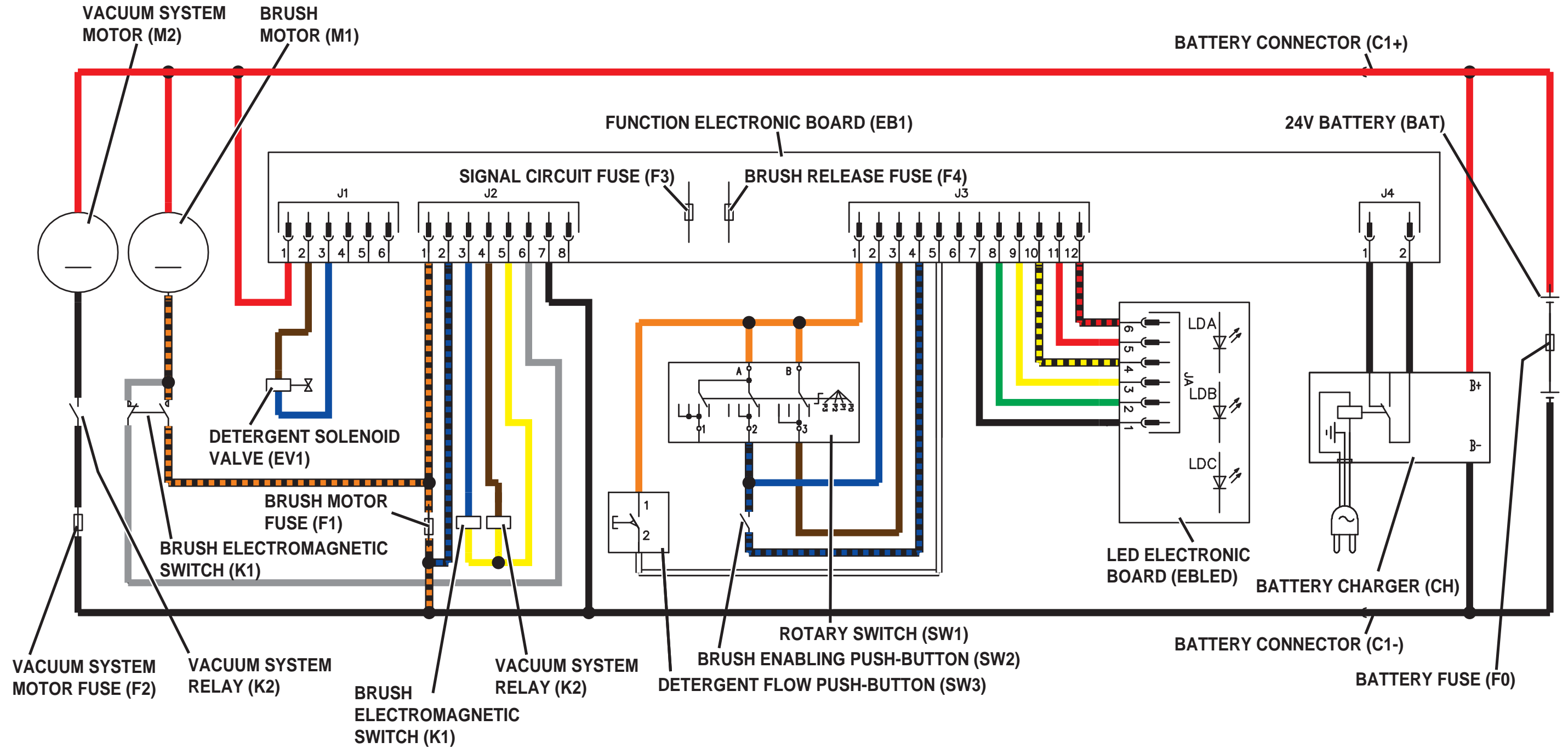

## Specifications

General	Values
Total absorbed power	29 A (0.75 kW)
Battery compartment size	13.7x17.7x10.2 in (350x350x260 mm)
Battery voltage	24 V
Standard batteries (2)	12 V - 50 Ah C5 (AGM) Spiracell
Battery charger	100-240 VAC
Work autonomy (standard batteries)	1.5 hour

# Recovery System

## Functional Description

The water recovery system removes the dirty water from the floor and pipes it to a recovery tank. When the machine is running, the dirty water on the floor is collected by the squeegee blades and collected through the slots in the same, piped through the vacuum hose and into the tank by the airflow created by vacuum motor (M2). The dirty water is piped into the recovery tank, while the airflow continues to the vacuum fan. The vacuum system motor (M2) is supplied by the relay (K2) which is driven by the function electronic board (EB1) when the rotary switch (SW1) is turned to 1 or 3. The circuit is protected by the fuse (F2). The automatic float in the vacuum grid stops vacuum system motor (M2) from collecting any liquids.

When the automatic float closes and shuts down the vacuum system, the vacuum system motor noise will increase and the floor will not be dried. When the recovery tank is full it can be emptied through the drain hose.

## Wiring Diagram

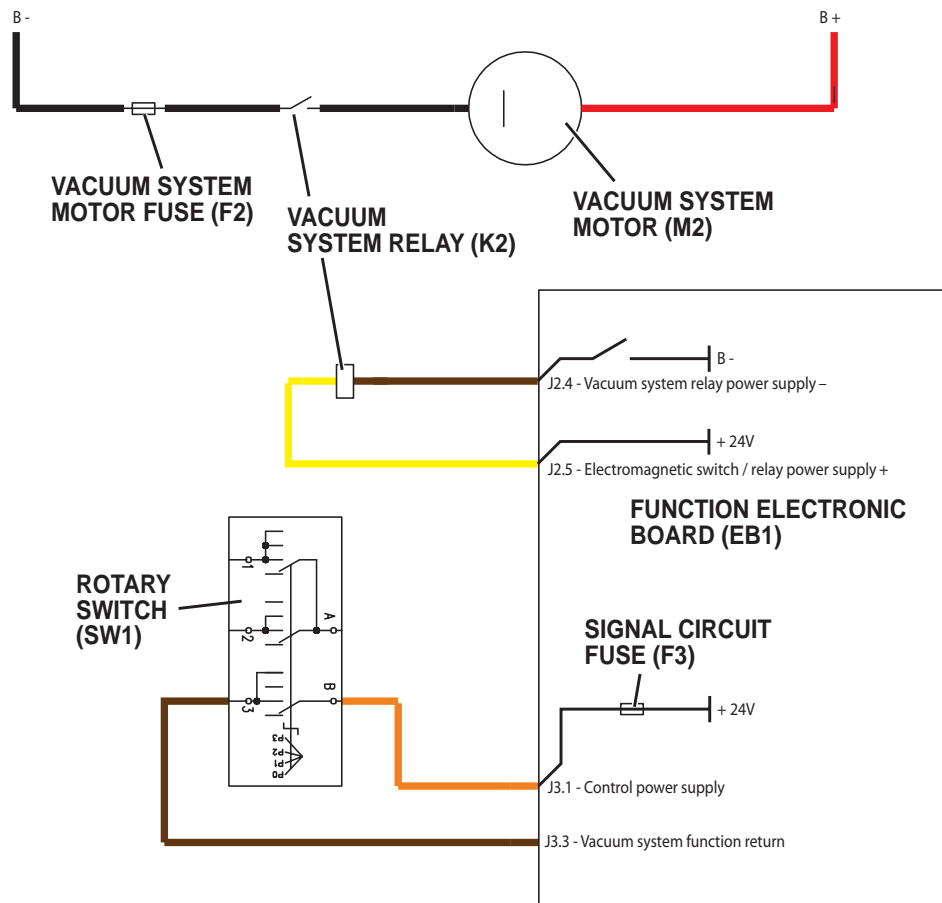

## Component Locations

- Recovery tank
- Vacuum grid with automatic shut-off float
- Recovery tank cover
- Cover gasket
- Recovery water drain hose
- Squeegee vacuum hose
- Vacuum system motor (M2)
- Electrical component box
- Vacuum system motor fuse (F2)
- Vacuum system relay (K2)

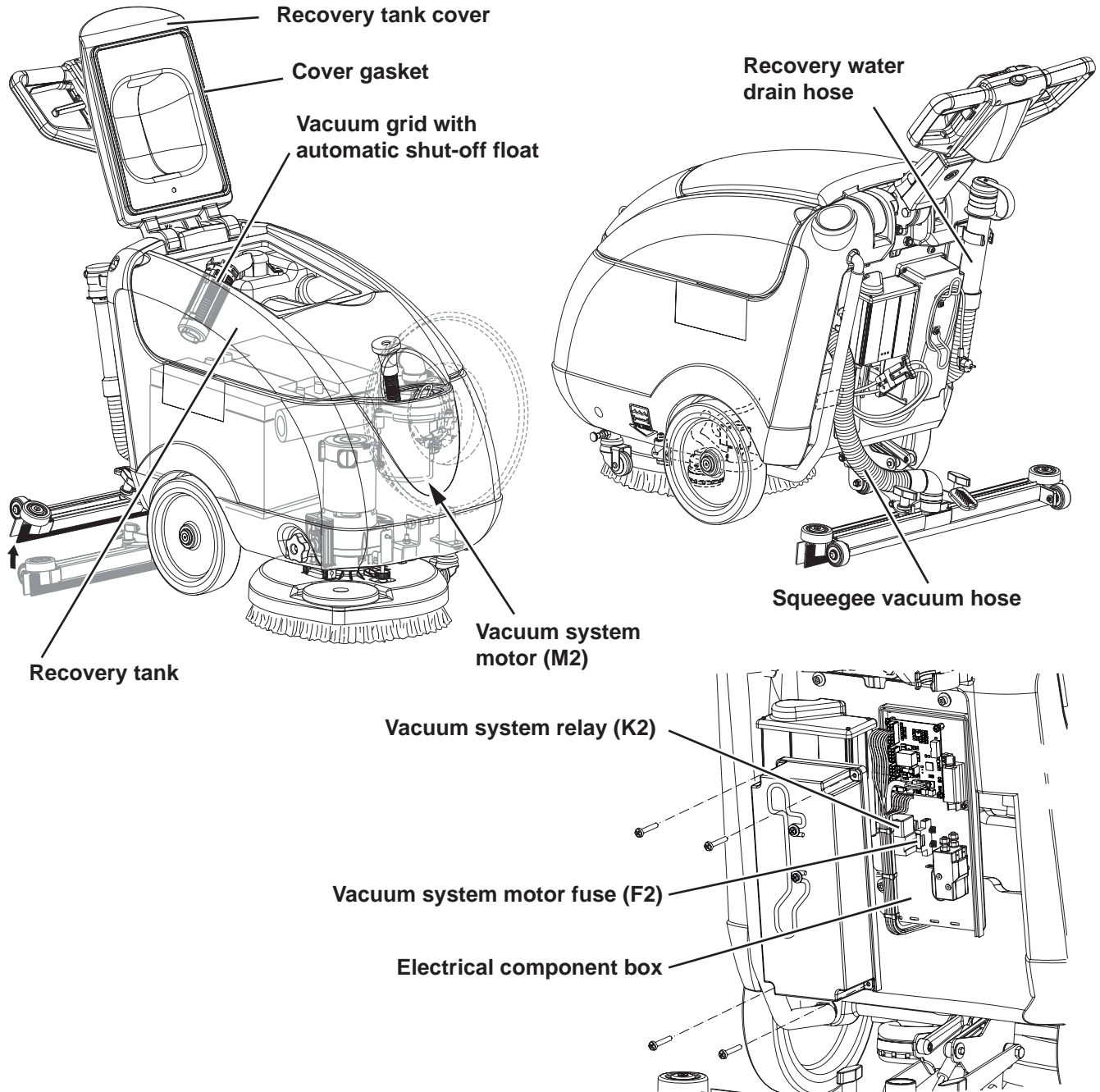

## Maintenance and Adjustments

### Tank and Vacuum Grid Cleaning

1. Drive the machine to the appointed disposal area.
2. Turn the machine program selection knob to “0”.
3. Open the recovery tank cover (A), then clean and wash the cover, the tank (B) and the vacuum grid (C) with clean water.

If necessary, release the fasteners (D) and open the grid (C), remove the float (E), clean all the components and then reinstall them.

If necessary, clean also the solution tank.

Drain the water from the tanks with the relevant drain hoses.

4. Check the recovery tank cover gasket (F) for integrity.

The gasket (F) must be efficient, because it creates vacuum in the tank that is necessary for vacuuming the recovery water.

If necessary replace the gasket (F) by removing it from its housing (G). When assembling the new gasket, install its junction (H) in the central rear area as shown in the figure.

5. The gasket (F) must be in good shape, as it is necessary for the recovery tank stay sealed.
6. Close the recovery tank cover (A).

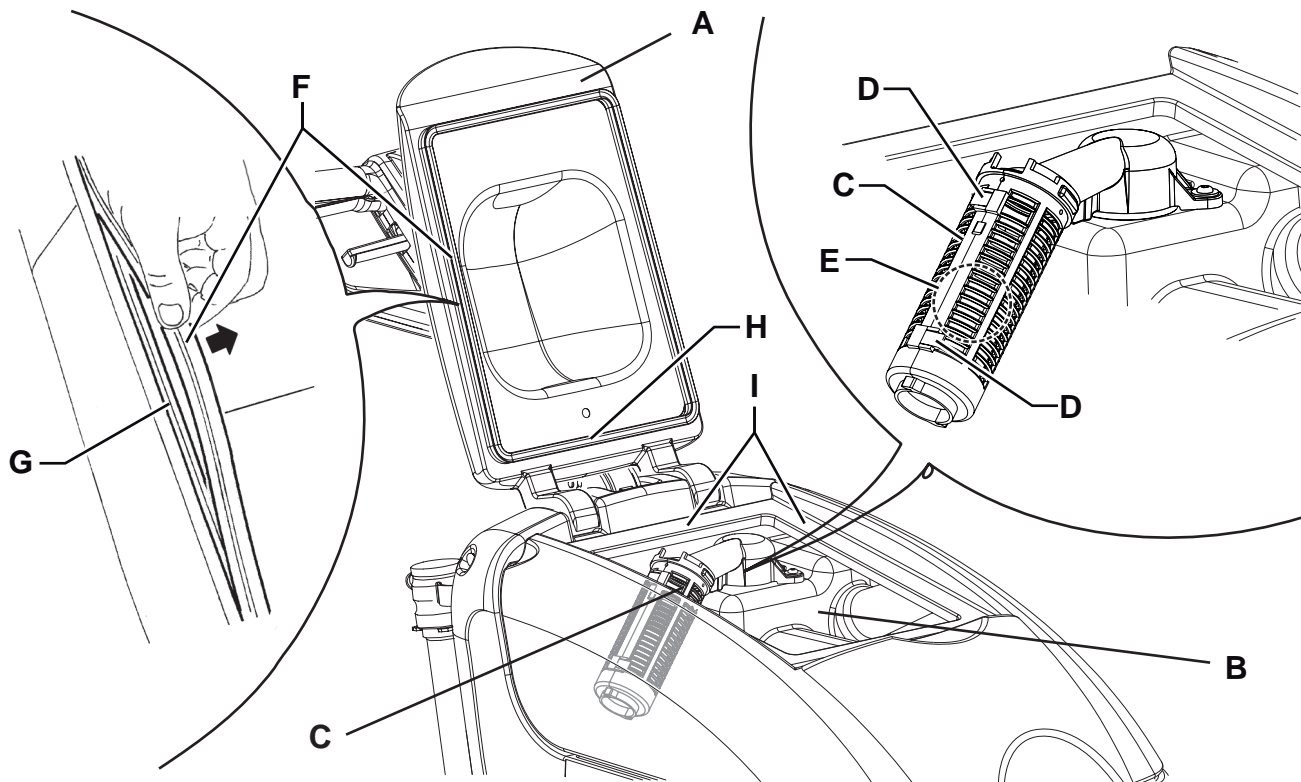

## Troubleshooting

Trouble	Possible Causes	Remedy
The vacuum system motor (M2) does not turn on	The vacuum system motor carbon brushes are worn	Replace
	The rotary switch (SW1) is broken	Replace
	The vacuum system motor is faulty	Check the amperage.
		Check the carbon brushes.
		Replace.
	The fuse (F2) is open	Replace
The relay (K2) is broken	Replace	
The recovery water vacuuming is insufficient or there is no vacuuming	The vacuum grid with automatic shut-off float is activated because the recovery tank is full	Drain the recovery tank
	The vacuum grid is dirty	Clean
	The tank cover is not correctly positioned	Adjust
	The tank cover gasket is not efficient	Clean/replace
	The vacuum system motor filter is dirty	Clean
	The vacuum gaskets are damaged or do not match perfectly	Repair or replace
	The squeegee vacuum hose is broken	Replace
	The recovery tank vacuum hose is broken	Replace

## Removal and Installation

### Vacuum System Motor Amperage Check



**Warning!** This procedure must be performed by qualified personnel only.

1. Check that the squeegee and the vacuum hose are clean and that there is no dirt in their inner parts.
2. Keep the squeegee lifted.
3. Remove the screws (A), then remove the electrical component box cover (B).



**Warning!** Do not touch uncovered electrical components while performing the following steps.

4. Apply the Amp clamp (C) on the electrical cable (D) of the vacuum system motor on the relay output (E).
5. Turn on the vacuum system and check that the vacuum system motor amperage is between 13 and 17 A at 24V.  
Stop the vacuum system.  
Turn the machine program selection knob to “0”.

Remove the Amp clamp (C).

If the amperage is higher, perform the following procedures to detect and correct the abnormal input:

- Check that the vacuum system motor fuse (F2) is properly tightened.
- Check the condition of the vacuum system motor carbon brushes.
- Remove the vacuum system motor (see the procedure in the Vacuum System Motor Disassembly/Assembly paragraph), and check the condition of all its components.

If the above-mentioned procedures do not produce the correct readings for the vacuum system motor amperage, the motor must be replaced (see the procedure in the Vacuum System Motor Disassembly/Assembly paragraph).

### Reassembly

6. Assemble the components in the reverse order of disassembly.

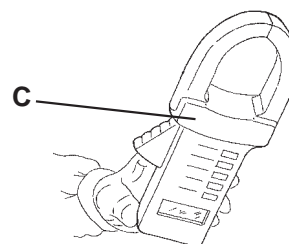
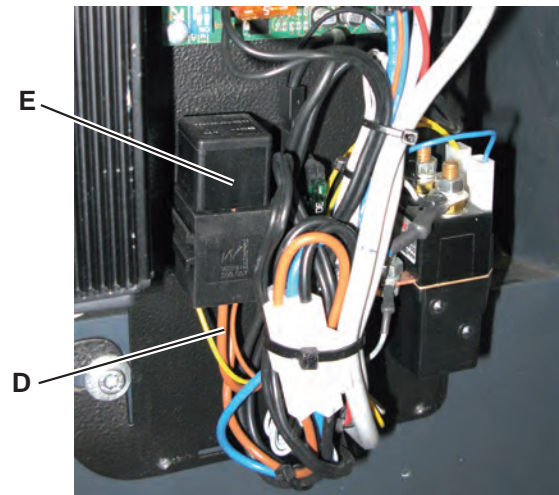
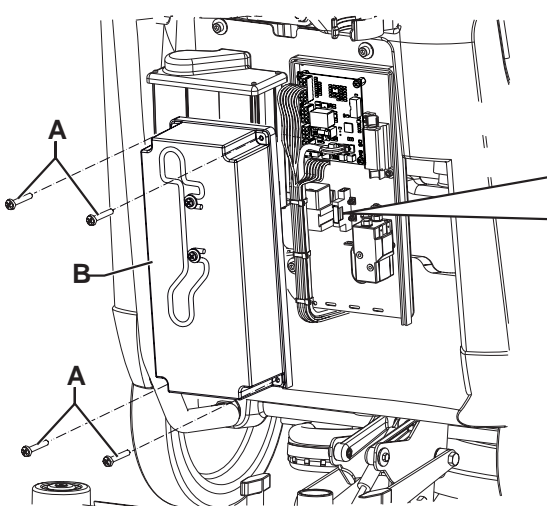

## Vacuum System Motor Carbon Brush Check/Replacement

### Disassembly/Check

1. Remove the vacuum system motor (see the procedure in the Vacuum System Motor Disassembly/Assembly paragraph).
2. At the workbench, remove the vacuum system motor guard (A) by disengaging its inner fasteners (B).
3. With a proper tool, remove the tin soldering spot (C) between both lead-in wires (D).
4. Disconnect the lead-in wires (D).
5. Remove the screws (E) and remove the carbon brushes (F).
6. Check the carbon brushes (F) for wear. The carbon brushes are worn when:
  - The contact with the motor armature is insufficient
  - The contact surface is not integral
  - The stroke is less than 0.12 in (3 mm)
  - The spring is broken

In this cases, replace both motor carbon brushes.

### Assembly

7. Assemble the components in the reverse order of disassembly, and note the following:
  - after connecting the lead-in wires (D) fasten them with a tin soldering spot (C).

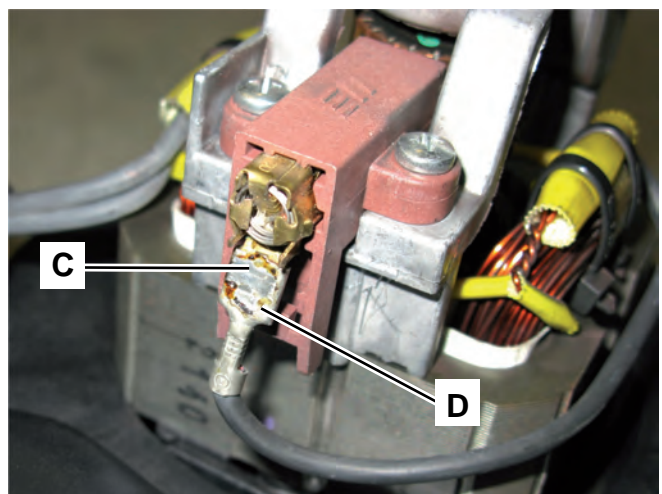
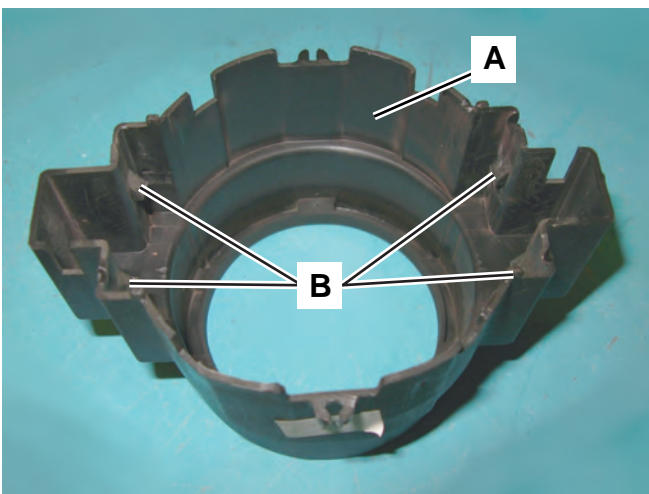
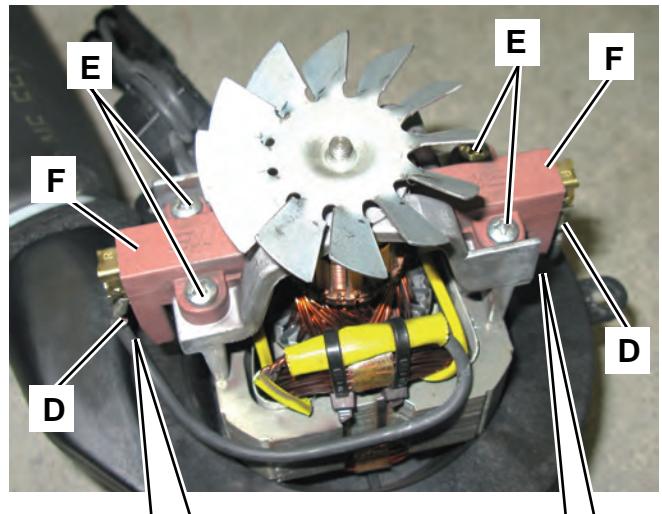
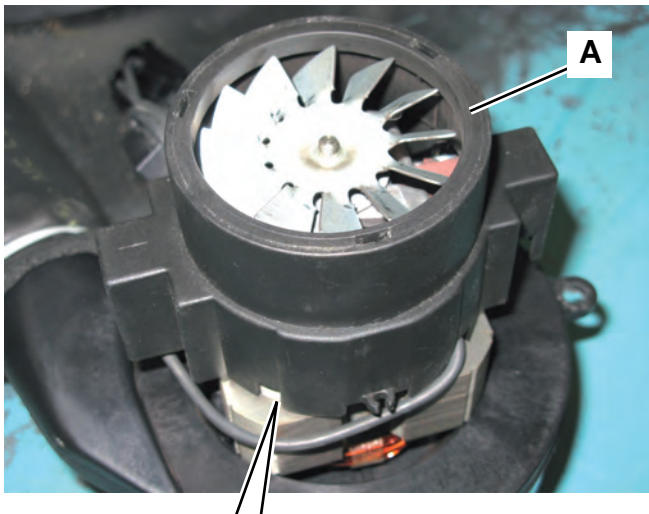

## Vacuum System Motor Disassembly/Assembly

### Disassembly

1. Remove the recovery tank.
2. Loosen the band (A) and disconnect the hose (B) from the vacuum system motor below.
3. Remove the guard (C).
4. Disconnect the connector (D) of the vacuum system motor (E).
5. Remove the screws (F), then lift them from the housing and remove the vacuum system motor (E).
6. If necessary, remove the sound-proof panels (G) and (H) from the motor.

### Assembly

7. Assemble the components in the reverse order of disassembly.

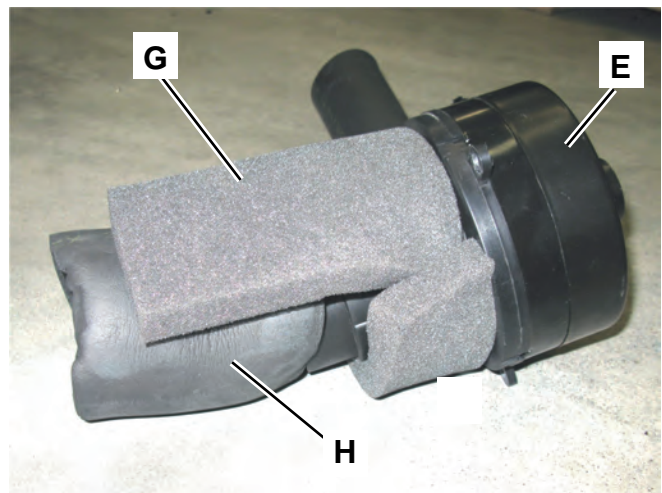
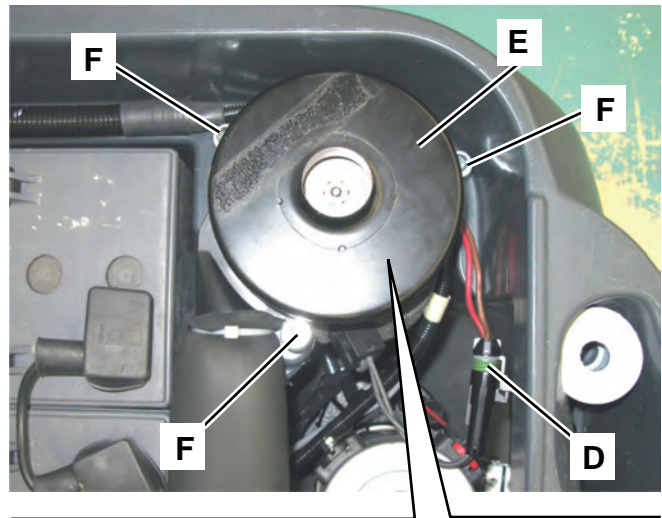
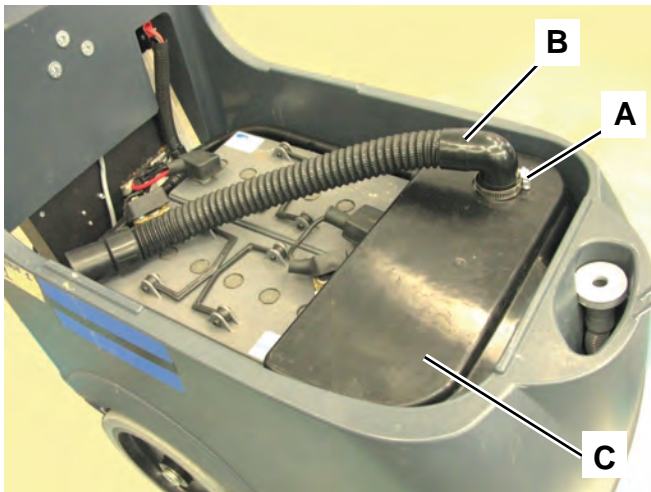

## Specifications

General	Values
Recovery tank capacity	5.5 US gal (21 liters)
Vacuum system motor power	0.4 hp (300 W)
Vacuum water lift (blocked)	47.2 inH <sub>2</sub> O (1,200 mmH <sub>2</sub> O)

# Scrub System, Disc

## Functional Description

The disc brush system can be started by the operator. The disc brush rotates counter-clockwise.

The brush system, when turning, cleans/washes the floor surface and assists machine forward movement. The deck, where brushes suitable for cleaning the particular type of floor are installed, is the main part of the scrub system. The brush deck is fixed and integrated in the machine with a support bracket. The adjusting systems adjusts the forward speed, while the handwheel on the deck adjusts the machine straight-forward drive.

The brush working pressure is functional to the machine designed balance.

The brush motor (M1) is supplied by the electromagnetic switch (K1) which is driven by the function electronic board (EB1) when the rotary switch (SW1) is turned to 1 or 2, and the brush enabling push-button (SW2) is pressed. The circuit is protected by the fuse (F1) and by the electronic protection system described in the Function Electronic Board Specifications chapter.

The system, once activated, uses the solution coming from the solution system, to wash the floor.

In case of brush motor overload, a safety system stops the brushes after about one minute of continuous

overload. The overload is shown by the three battery warning LEDs flashing simultaneously.

The overload is detected by monitoring the current flow sum on the motor. The current is measured by checking the voltage drop through the fuse (F1). If the voltage drop is higher than 40 mV, the 3 battery LEDs flash simultaneously and, if the overload persists, the motor stops after a variable delay, depending on the overload amount.

To start scrubbing again after a brush stop due to overload, cycle the rotary switch (SW1) off and then back on.

To work properly, the brush motor needs the following:

- Rotary switch (SW1) turned to 1 or 2
- Brush enabling push-button (SW2) pressed
- Charged batteries (the red LED must not be flashing).

### BRUSH RELEASE SYSTEM:

In order to release the brush from its hub, the brush motor starts running, then it is stopped quickly. Therefore the brush due to its inertia is disengaged from the hub. The system works better if the brush deck is lifted from the floor during this operation.

## Wiring Diagram

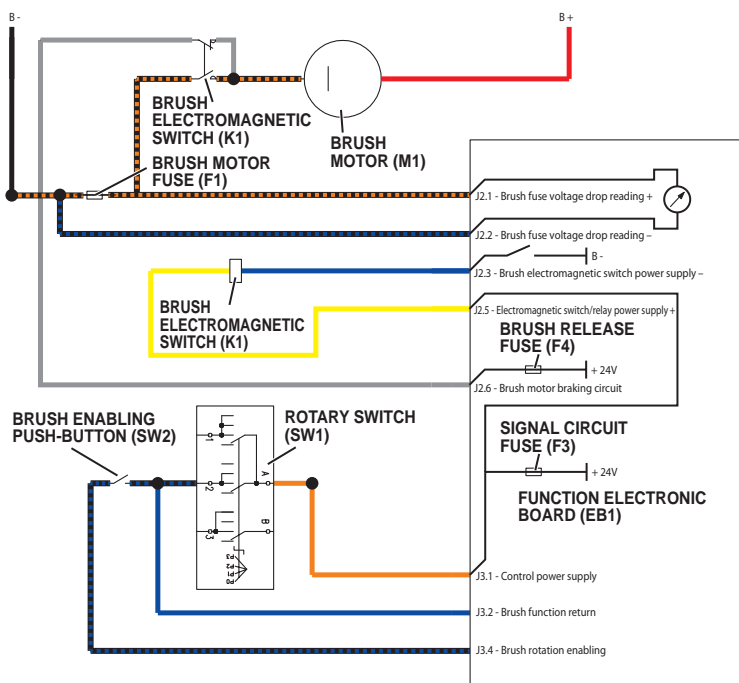

### Component Locations

- Disc brush deck
- Brush motor (M1)
- Drive hub
- Electromagnetic switch (K1)
- Brush motor fuse (F1)
- Brush release fuse (F4)
- Machine forward speed adjusting handwheel
- Machine straight forward movement adjusting handwheel

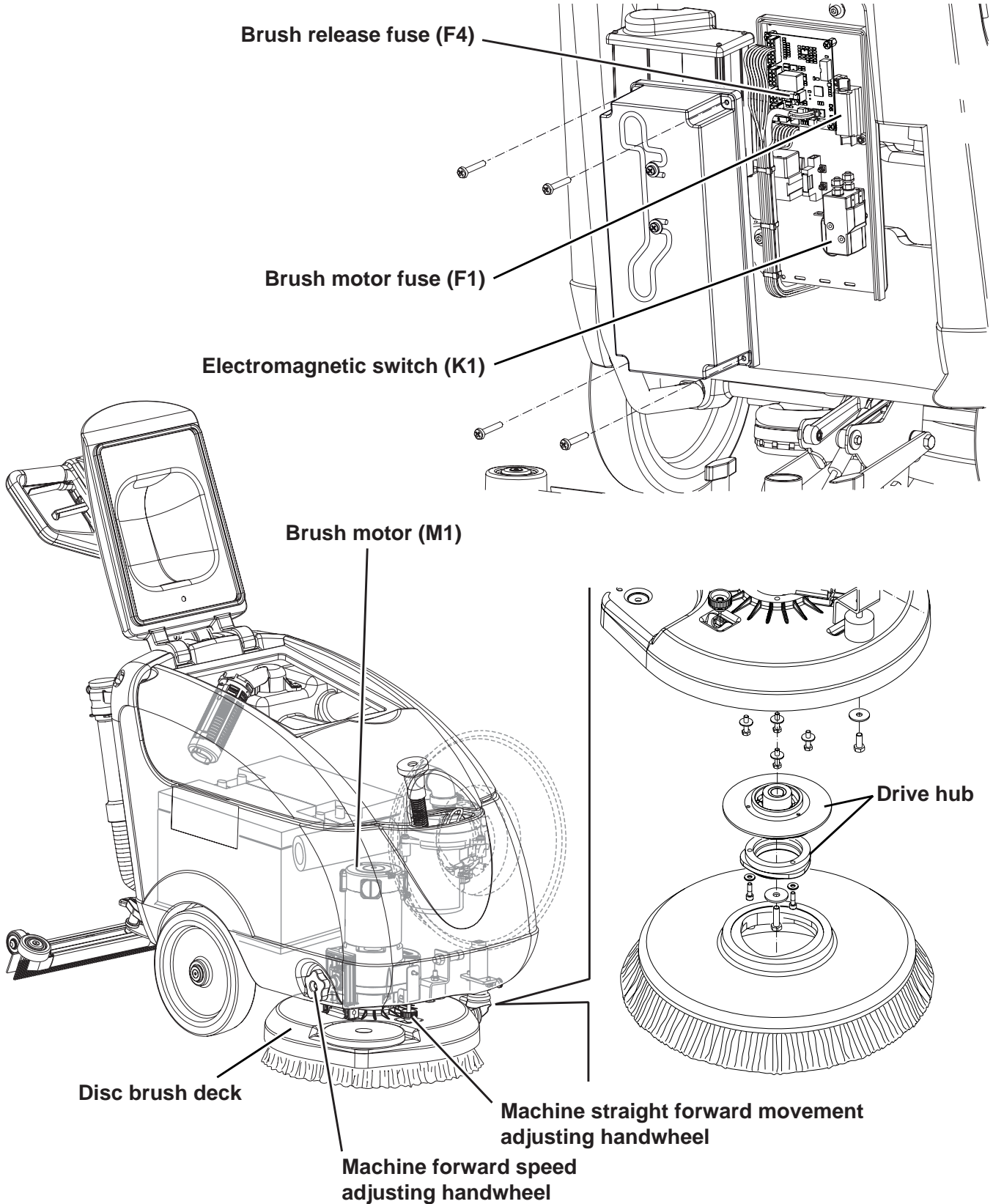

## Maintenance and Adjustments

### Brush Cleaning



**Warning!** It is advisable to wear protective gloves when cleaning the brush because there may be sharp debris.

1. Remove the brush (as shown in the User Manual).
2. Insert the positioning pin (A) and disengage the machine parking device (B).
3. Clean the brush with water and detergent.
4. Check the brush bristles for integrity and wear; if necessary, replace the brush.
5. Install the brush (as shown in the User Manual).

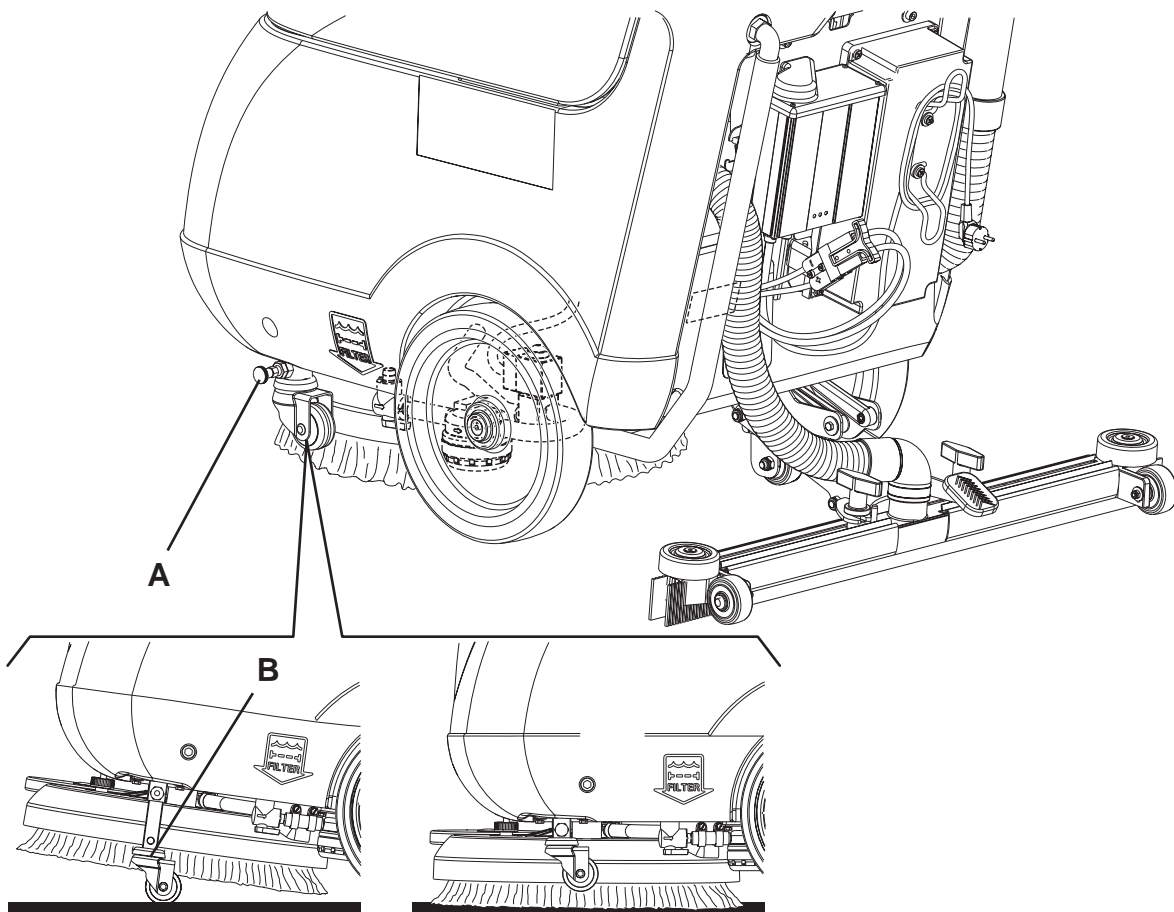

## Machine Forward Movement Adjustment



*Note: The machine speed and forward movement vary according to the type of floor to be cleaned and the choice of using the brush or the pad. If necessary, perform the following procedure.*

1. Adjust the machine speed with the handwheel (A) according to the following procedure:
  - Turn it counter-clockwise to increase the machine speed.
  - Turn it clockwise to decrease the machine speed.
2. If it is difficult to keep the machine moving straight-forwardly because it deviates to the left or to the right, adjust the knob (B) by turning it clockwise or counter-clockwise.
3. With the machine ready to operate, perform hands-on tests of the machine speed; if necessary, perform step 2 again.

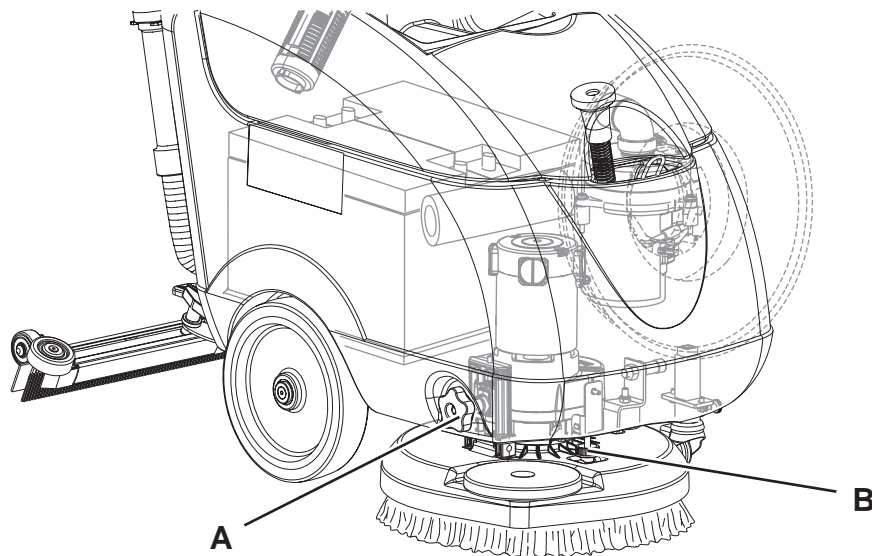

P200060

## Troubleshooting

### Open Circuit

- The fuse (F1) determines an open in the supply circuit of the brush deck motor. This system allows to prevent the circuits from being damaged under overload conditions.
- The open in the fuse can be caused by the following:
- Short circuit in the brush motor wiring harness; fault in the motor.

Trouble	Possible Causes	Remedy
The brush does not clean properly	The brush is excessively worn	Replace
The brush does not turn	Activation of motor overload	Restart the machine as shown in the User Manual
	The motor carbon brushes are worn	Replace
	The motor is faulty	Check the motor amperage/replace
	There are ropes or debris restraining the brush rotation	Remove and clean
	The fuse (F1) is open	Replace
	The motor electromagnetic switch (K1) is damaged	Replace
	The brush motor electromagnetic switch wiring harness is damaged	Repair
	The wiring harness between function electronic board (EB1) and brush motor electromagnetic switch (K1) is damaged	Repair
The brush release system does not work	The levers or the enabling push-button are broken	Replace
	The fuse (F4) is open	Replace.
	The electromagnetic switch (K1) is broken	Replace

## Removal and Installation

### Brush Motor Amperage Check



**Warning!** This procedure must be performed by qualified personnel only.

1. Remove the brush.
2. Remove the screws (A), then remove the electrical component box cover (B).



**Warning!** Do not touch uncovered electrical components while performing the following steps.

3. Apply the Amp clamp (C) on the electrical cable (D) of the brush motor on the electromagnetic switch output (E).
4. Turn on the brush (as shown in the User Manual) and check that the brush motor amperage is between 3 and 4 A at 24 V. Stop the brush rotation. Turn the machine program selection knob to “0”. Remove the Amp clamp (C). If the amperage is higher, perform the following procedures to detect and correct the abnormal

amperage:

- Check that the brush hub is free from foreign materials (ropes, dirt, ...) preventing it from turning.
- Check that the brush motor fuse (F1) is properly tightened.
- Check the condition of the brush motor carbon brushes
- Remove the brush motor (see the procedure in the Brush Motor Disassembly/Assembly paragraph), and check the condition of all its components.

If the above-mentioned procedures do not produce the correct readings for the brush motor amperage, the motor must be replaced (see the procedure in the Brush Motor Disassembly/Assembly paragraph).

### Reassembly

5. Assemble the components in the reverse order of disassembly.

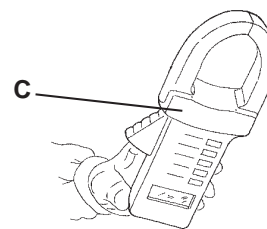
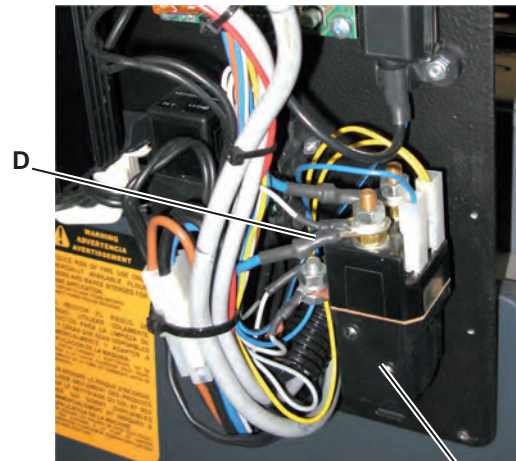
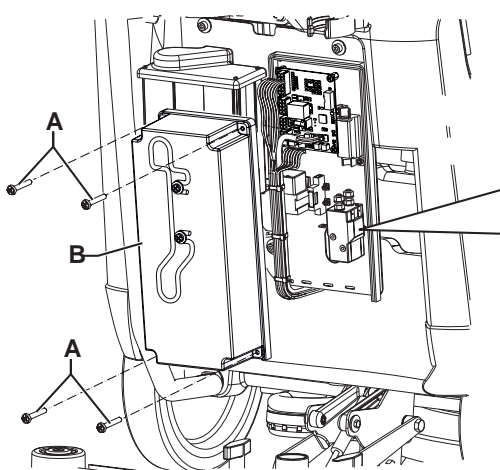

## Brush Motor Carbon Brush Check/Replacement

### Disassembly/Check

1. Remove the recovery tank (as shown in User Manual).
2. Loosen the band (A) and disconnect the hose (B) from the vacuum system motor below.
3. Remove the guard (C).
4. On the brush motor (D), if necessary, remove dirt from the area of the four carbon brush covers (E).
5. Turn and remove the four covers (E) (bayonet joint).
6. Remove the carbon brush nuts (F) with the lead-in wires.
7. Disengage the tabs (G) and remove the carbon brushes (H).
8. Check the carbon brushes (H) for wear. The carbon brushes are worn when:
  - The contact with the motor armature is insufficient
  - The contact surface is not integral
  - The stroke is less than 0.12 in (3 mm)
  - The spring is broken

In this cases, replace all motor carbon brushes.

### Assembly

9. Assemble the components in the reverse order of disassembly.

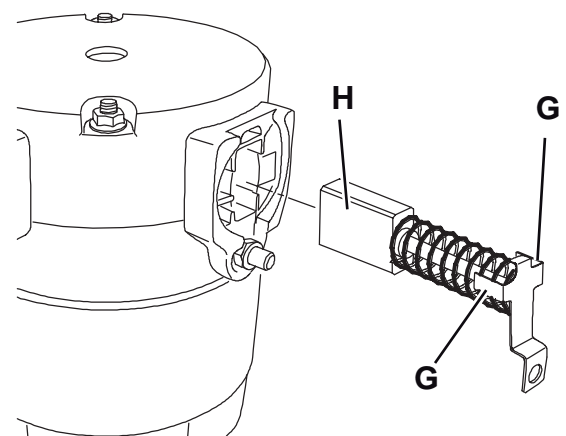
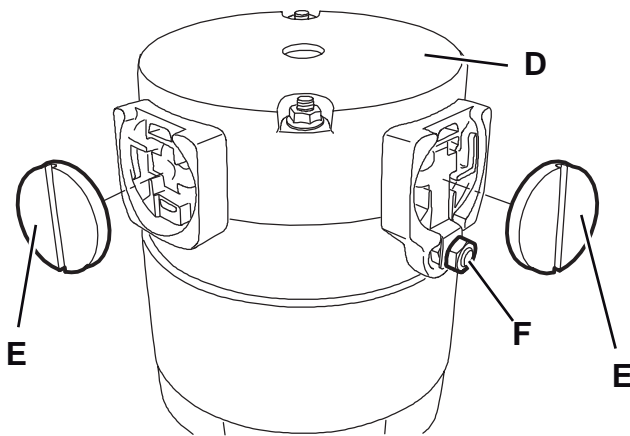
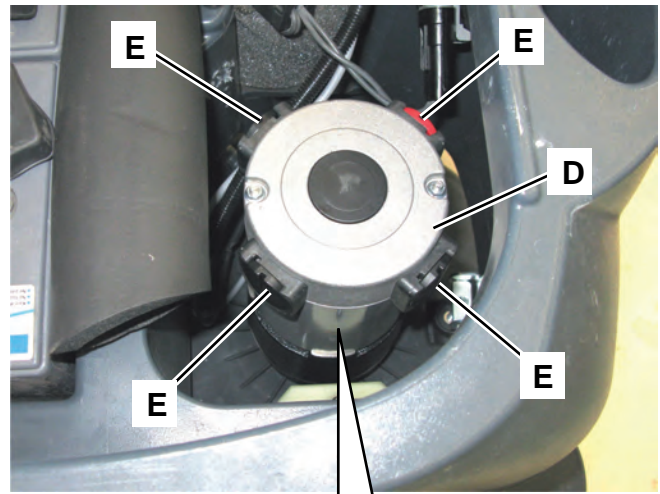
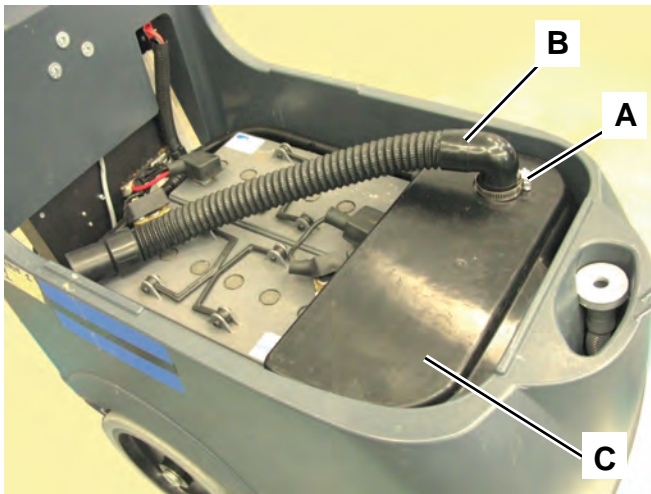

## Brush Deck Disassembly/Assembly



Note: The figure shows the 520 Watt-motor; the 450 Watt-motor is similar.

### Disassembly

1. Remove the recovery tank and the solution tank (as shown in User Manual).
2. Remove the brush (as shown in the User Manual).
3. If possible, place the machine on a hoisting system.  
Make sure that the machine cannot move independently.
4. Turn the machine program selection knob to “0”.
5. Disconnect the battery connector (red).
6. On the machine front left side, remove the screw inside the hole (A).
7. With the wheel (B), fully unscrew the threaded pin (C) from the upper nut screw.
8. Turn the handwheel (D) clockwise until the end of the stroke (brush lowering).
9. Unscrew the nut (E) and remove the screw (F) thus letting the brush deck (G) lowering down.
10. Lift the machine front side (P) and keep it lifted.
11. Loosen the clamp (H) and disconnect the hose (I).

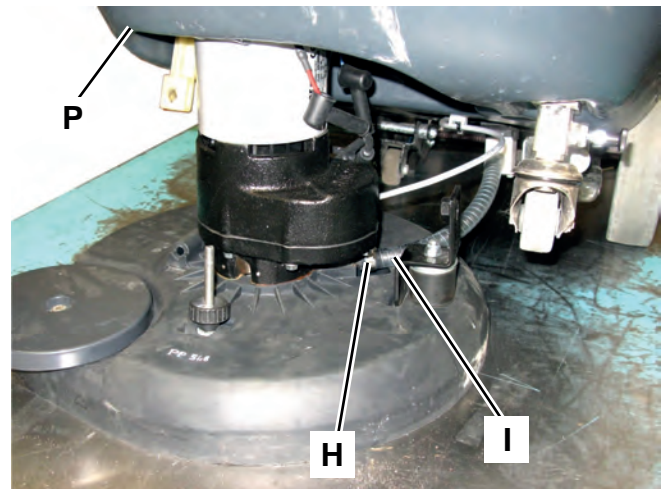
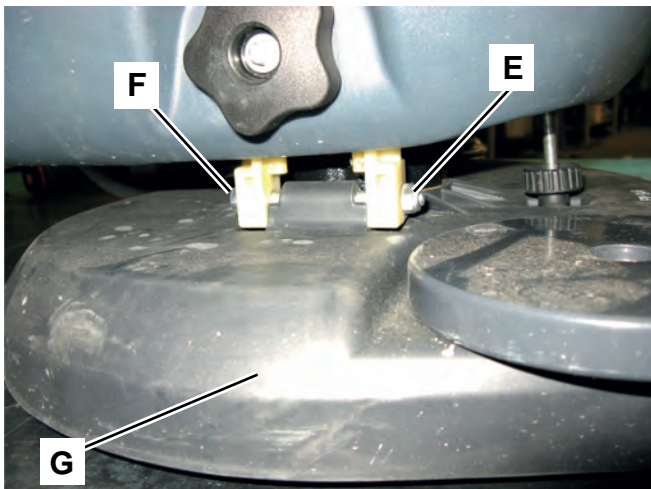
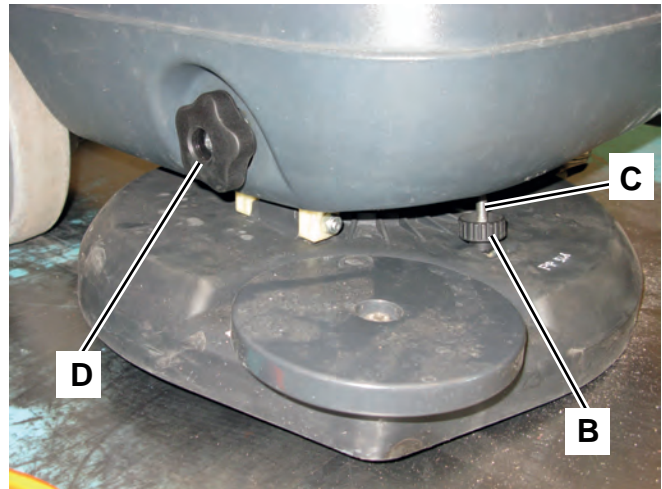
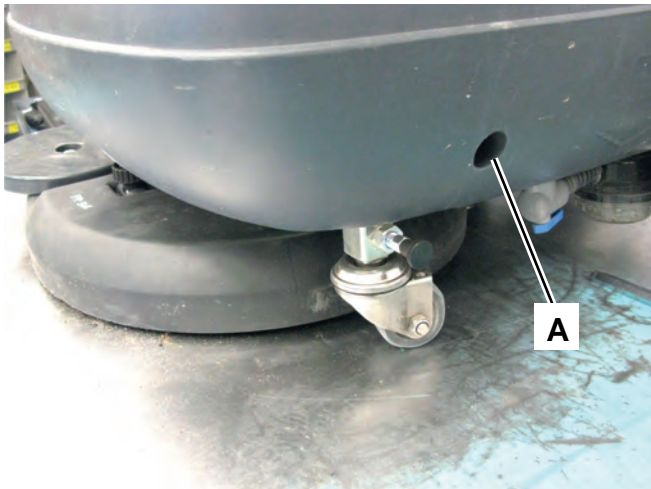

### Brush Deck Disassembly/Assembly (Continues)

13. Remove the brush deck (J) by turning it as shown in the figure, then lay it on a flat surface.
14. Cut the clamp (K).
15. Remove the four protecting caps (L) of the four electrical connections (M) of the brush motor (N).
16. Mark the position of each of the four electrical connections (M) to make subsequent assembly easier.  
Remove the nuts and disconnect the four electrical connections (M) from the motor.
17. Retrieve the brush deck (J).

### Assembly

18. Assemble the components in the reverse order of disassembly.

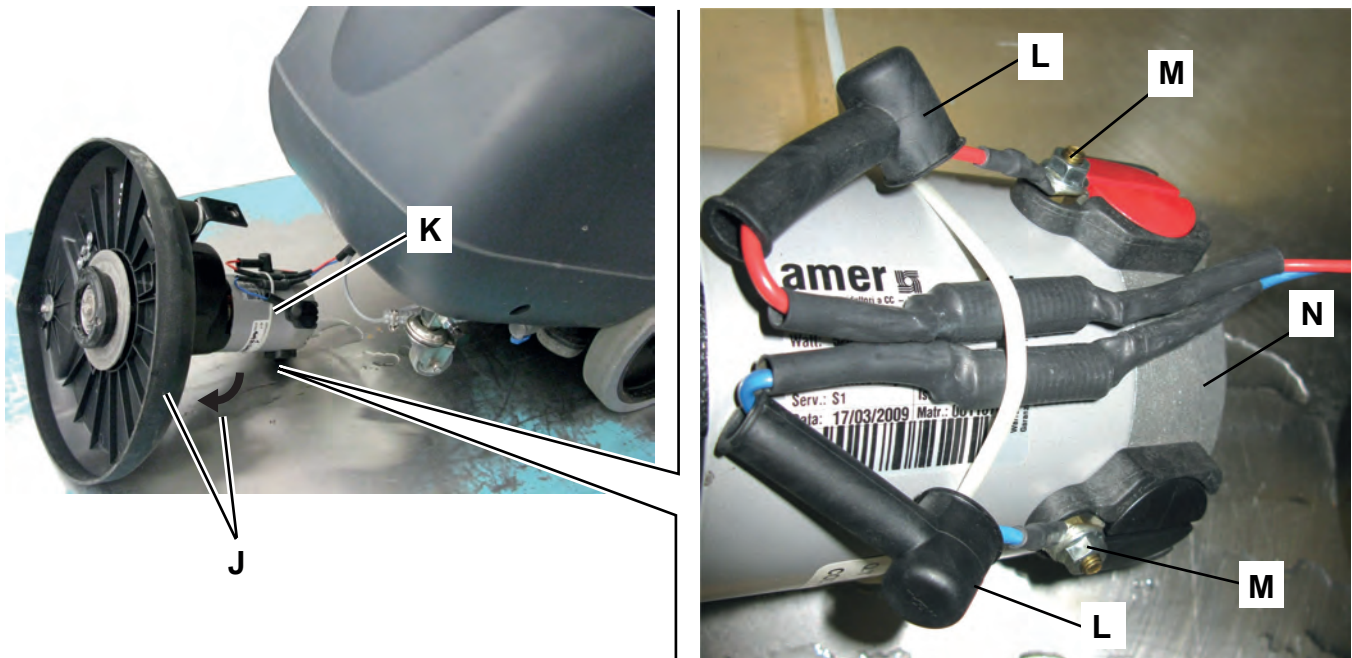

P200064

## Brush Motor Disassembly/Assembly

### Disassembly

1. Remove the brush deck (see the procedure in the Brush Deck Disassembly/Assembly paragraph).
2. On the lower side of the deck, remove the centre screw (A).
3. Remove the flange (B).
4. Remove the spacer (C) and the key (D) from the hub (E).
5. Remove the screws (F) and remove the brush case (G).
6. Retrieve the brush motor (H).

### Assembly

7. Assemble the components in the reverse order of disassembly.

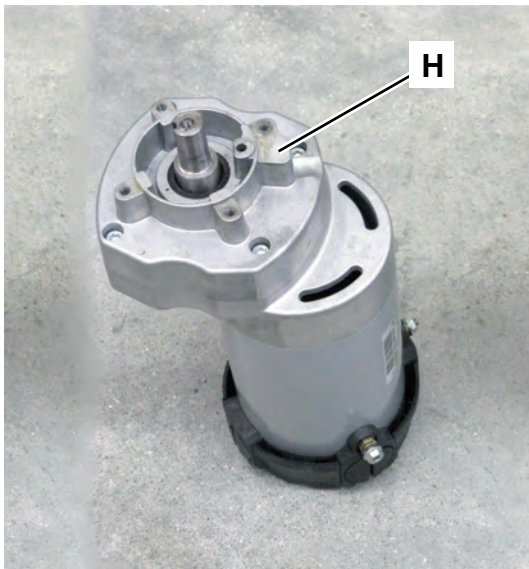
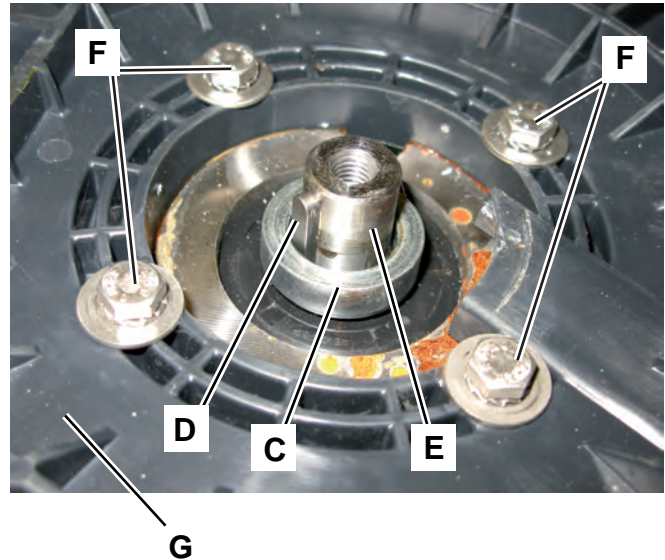
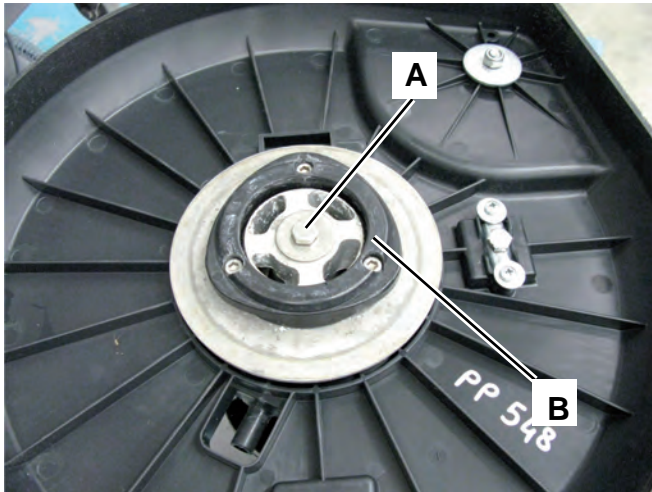

## Brush Deck Adjuster Disassembly/Assembly

### Disassembly

1. Remove the brush deck (see the procedure in the Brush Deck Disassembly/Assembly paragraph).
2. On the front right side of the machine, remove the screw (A) and the handwheel (B).
3. Remove the nut (C) and, from inside the wall, remove the deck adjuster (D).

### Assembly

4. Assemble the components in the reverse order of disassembly.

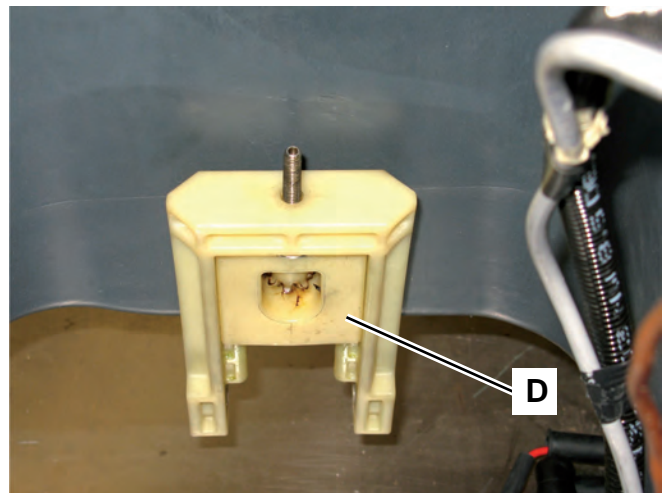
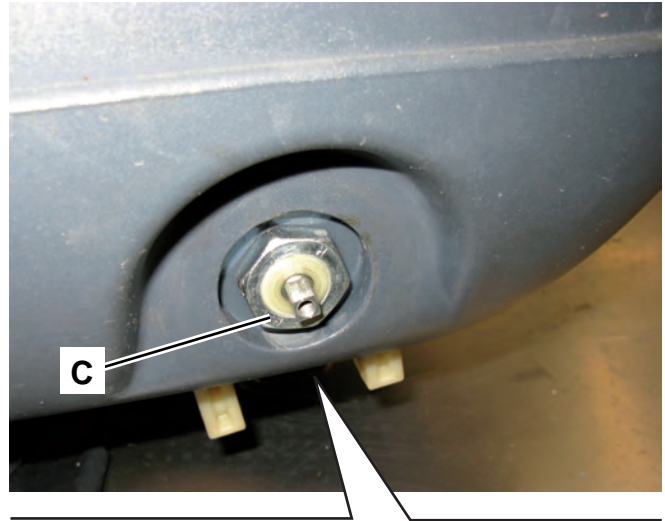
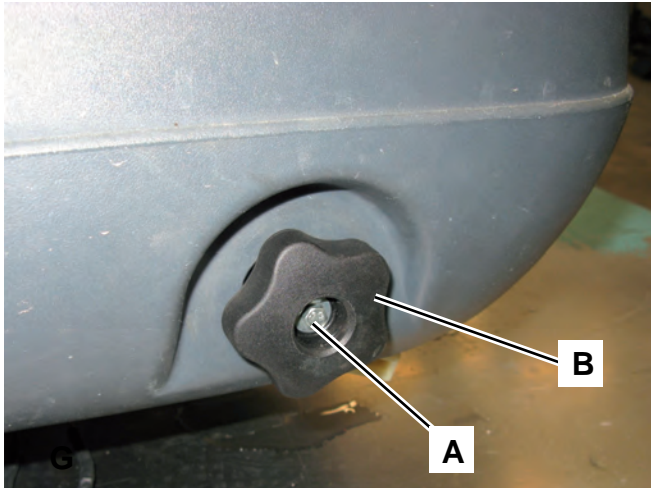

## Specifications

General	Values
Brush/pad diameter	17 in (430 - 432 mm)
Brush pressure with full tank and lowered squeegee	77 lb (35 kg)
Brush motor power	0.6 hp (450 W)
Brush motor speed	155 rpm
Brush motor amps	3 - 4 A, No load

# Solution System

## Functional Description

The solution system supplies the detergent to the brush when cleaning the floor. The solution tank is also the main machine body. There is a manual valve on the left side of the tank to close the water supply whenever maintenance must be performed on the machine.

The detergent quantity is adjusted by the operator with the push-button (SW3). The solution flows from the tank to the tap, through the filter and solenoid valve (EV1) and then to the brush deck.

The solenoid valve (EV1) is supplied by the function electronic board (EB1) when the rotary switch (SW1)

is turned to 1 or 2, the brush activation push-button (SW2) is pressed and the push-button (SW3) setting is different from 0 (3 LEDs off).

The circuit is protected by the fuse (F3) on the function electronic board (EB1).

The solution valve is pulse width modulated to meter the flow rate:

Solution flow push-button setting (SW3)	LED display	Solenoid valve ON time (EV1)	Solenoid valve OFF time (EV1)
0		-	Always OFF
1		1 sec	5 sec
2		3 sec	3 sec
3		Always ON	-

## Wiring Diagram

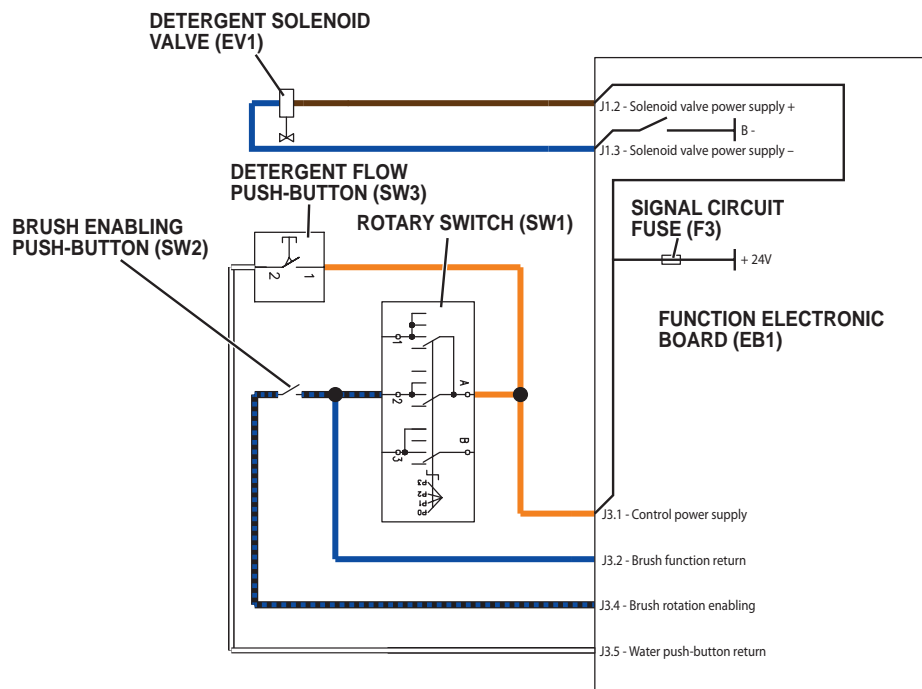

## Component Locations

- Solution tank
- Solution opening/closing valve
- Solution filter
- Solenoid valve (EV1)
- Solution drain and level check hose

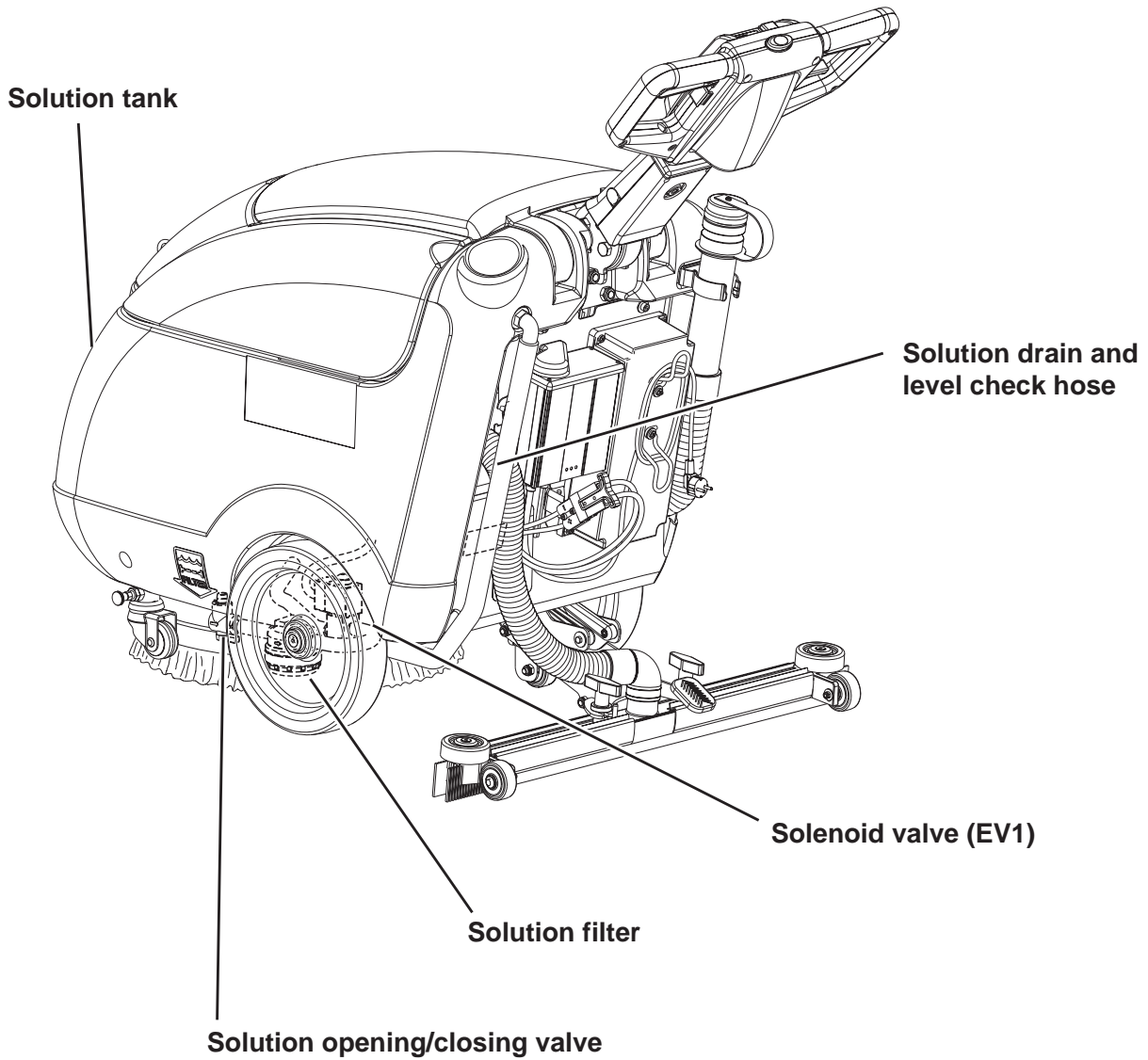

## Maintenance and Adjustments

### Solution Filter Cleaning

1. Drive the machine on a level floor.
2. Turn the machine program selection knob to “0”.
3. Operating under the machine, in front of the left rear wheel, close the solution valve (A).

The valve (A) is closed when it is in the position (B) and it is open when it is in the position (C).

4. Remove the transparent cover (D) and the gasket (E), then remove the filter strainer (F). Clean and install them on the support (G); install the gasket (E) and the filter strainer (F) properly on the cover (D) and on the support (G).
5. Open the valve (A) by turning it to position (C).

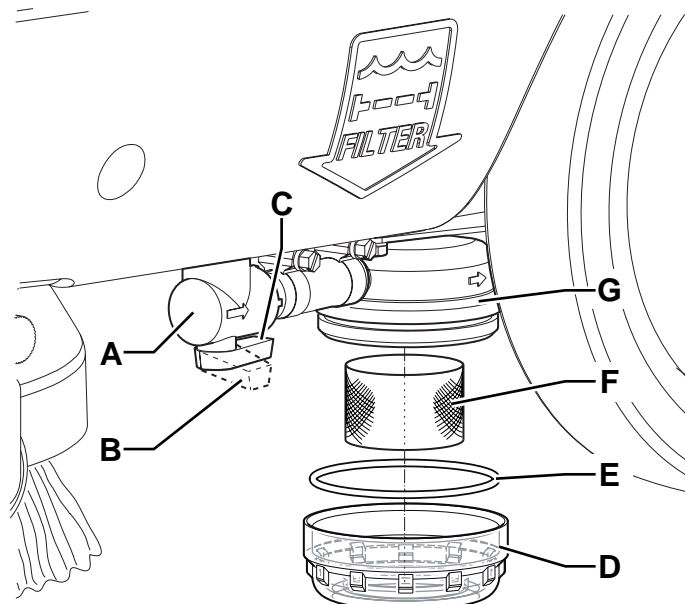

P200068

## Troubleshooting

Trouble	Possible Causes	Remedy
Small amount of solution or no solution reaches the brush	The tank filter (optional) is clogged/dirty	Clean
	The solution filter is clogged/dirty	Clean
	The solenoid valve (EV1) is faulty or the electrical connection is open	Replace the solenoid valve or repair the electrical connection
	There is dust/debris in the tank or in the detergent hoses, obstructing the solution flow	Clean the tank/hoses
	There is an open in the solenoid valve fuse/electronic board (F3)	Replace
The solution reaches the brush also when the machine is off	The solenoid valve (EV1) is dirty/broken	Clean/replace

## Specifications

General	Values
Solution tank capacity	6.0 US gal (23 liters)
Min/max solution flow	0.1 / 0.42 gpm (0.4 / 1.6 liters/min)
Solution valve winding resistance	50 $\Omega$ - 24V

## Squeegee System

---

### Functional Description

The squeegee system cleans the liquid off the floor, which is then collected by the recovery system.

The squeegee is equipped with wheels; the pressure of the blades on the floor depends on a gas spring built in the support, and on the weight of the system.

The squeegee is fastened to the machine by two wing nuts in the squeegee support slots. In case of fixed obstacles, the quick-fit system allows for squeegee to break away from the bracket in order to prevent damage to the squeegee support.

The squeegee support is hinged to the machine which allows the squeegee to turn sideways.

The 2 blades have different hardness and work side:

- Front blade; to be used only on the ruled side forward to convey the water towards the centre of the squeegee.
- Rear blade; to be used only on the smooth side forward to dry and collect water.

Each blade has 2 functional edges that can be used before it needs replacing.

The design and the central duct make it easy for the squeegee to clear the water.

The squeegee system can be lifted and lowered by the pedal.

To lift the squeegee it is also possible to tilt the machine backward until the squeegee is raised.

### Component Locations

- Squeegee
- Squeegee blades
- Squeegee holder
- Blade mounting springs
- Squeegee mounting handwheels
- Squeegee lifting/lowering pedal
- Gas spring

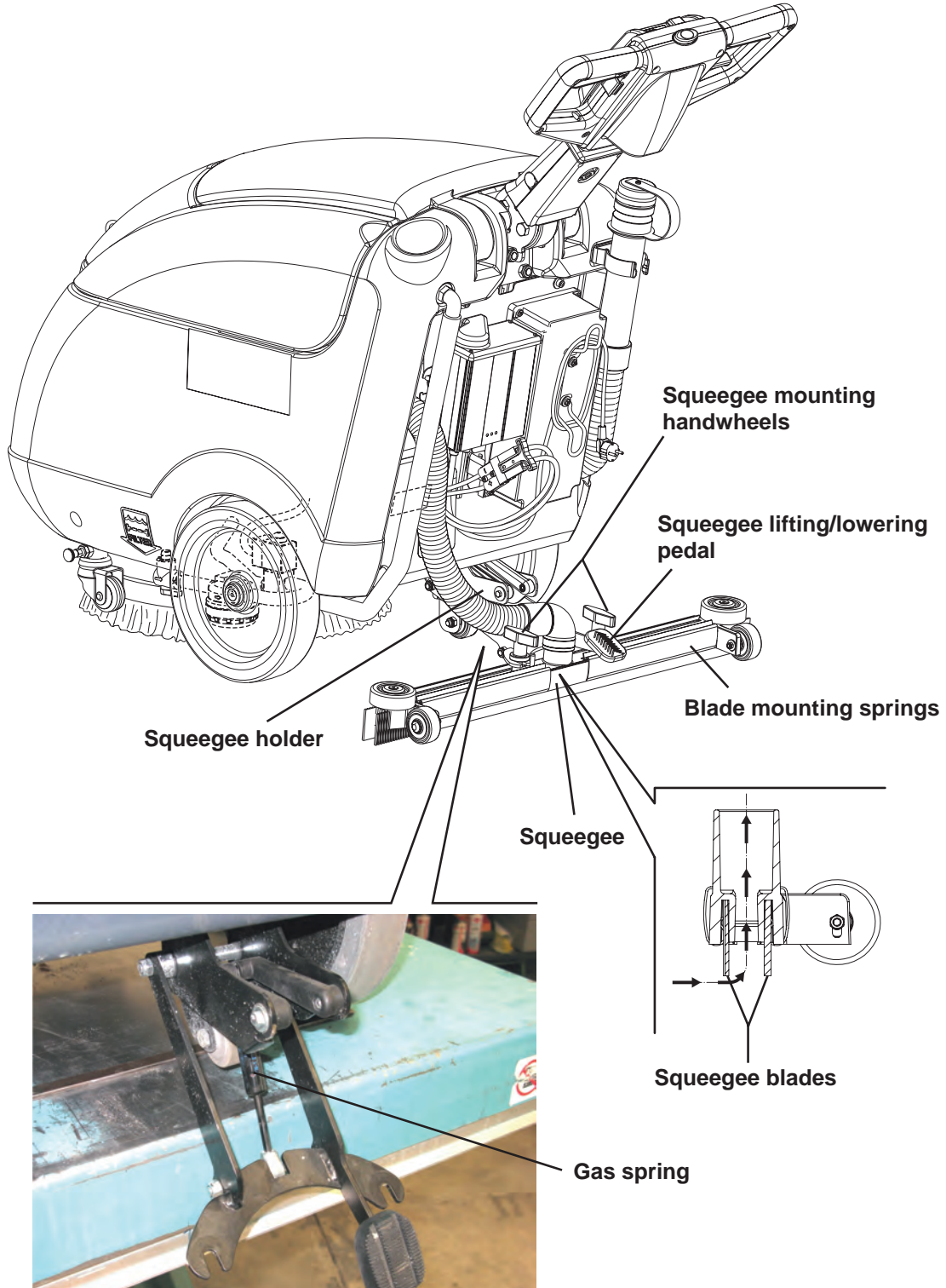

## Maintenance and Adjustments

### Squeegee Cleaning



**Warning!** *It is advisable to wear protective gloves when cleaning the squeegee because there may be sharp debris.*

1. Drive the machine on a level floor. Make sure that the machine cannot move independently.
2. Turn the machine program selection knob to “0”.
3. Lower the squeegee with the pedal.
4. Disconnect the vacuum hose (A) from the squeegee (B).
5. Loosen the handwheels (C) and remove the squeegee (B).
6. Wash and clean the squeegee (B). In particular, clean the compartments (D) and the vacuum hole (E) from dirt and debris.
7. Check the front blade (F) and the rear blade (G) for integrity, cuts and tears; if necessary replace them (see the procedure in the following paragraph).
8. Assemble the components in the reverse order of disassembly.

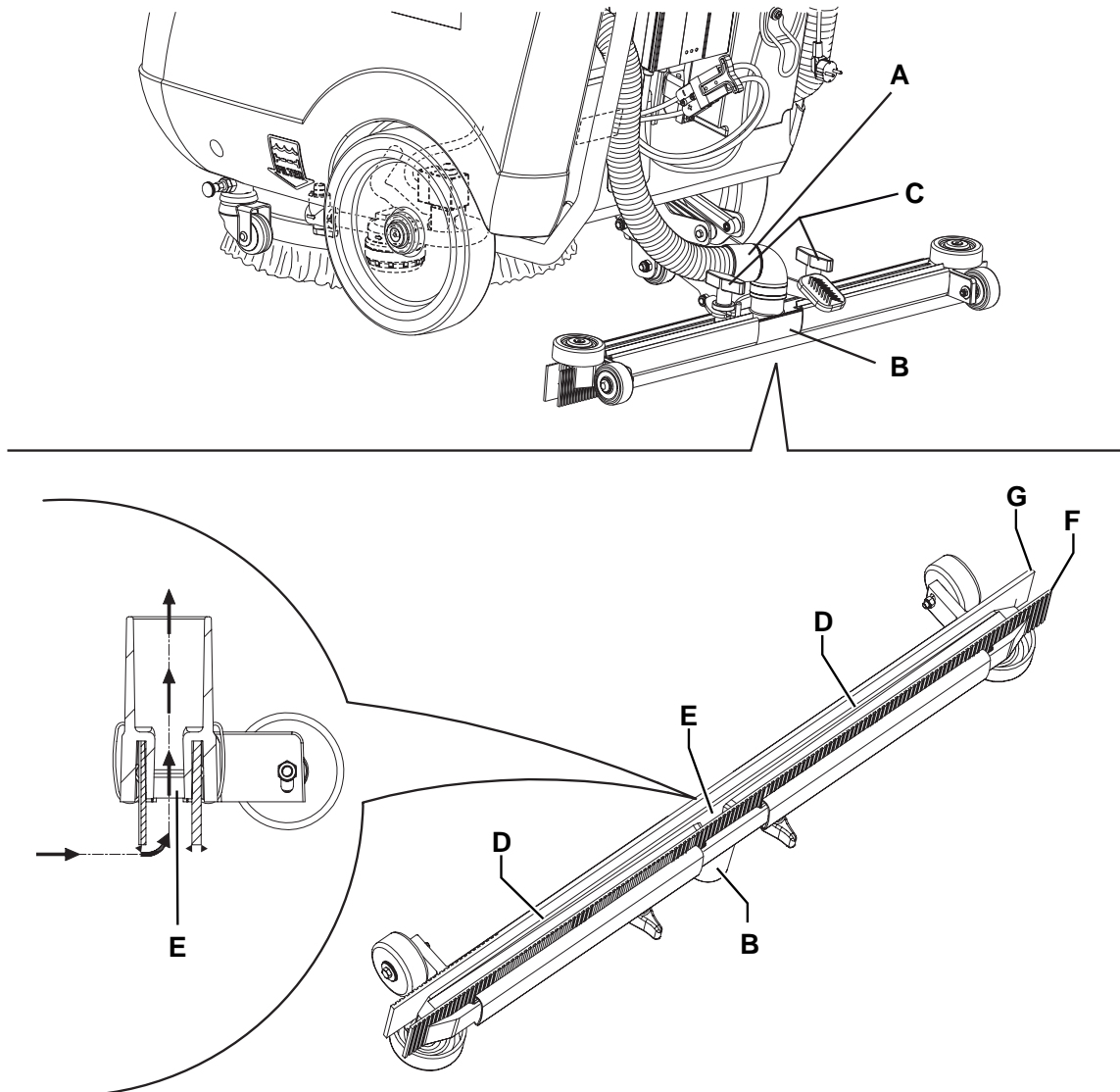

## Squeegee Blade Check and Replacement

1. Disassemble and clean the squeegee (see the procedure in the relevant paragraph).
2. Check that the edge (A) of the front blade and the edge (B) of the rear blade lay down on the same level, along their length; otherwise adjust their height according to the following procedure:
  - Remove the mounting springs (C), then adjust the front neutral color brown color blade (D) and the rear neutral color blade (E).
  - Install the mounting springs (C) on the front and rear blades.
3. Check that the front blade (D) and the rear blade (E) are integral and free from cuts and lacerations; if necessary replace them. Also check the front corner (F) of the rear blade (E) for wear; if it is worn, overturn the blade to replace the worn corner with the other one (G), if it is integral. If the other corner is worn too, replace the blade.



**Caution!** *Mount both front and rear blades with the smooth side (H) toward the internal squeegee side [ruled side (I)].*

4. Assemble the squeegee (see the procedure in the relevant paragraph).

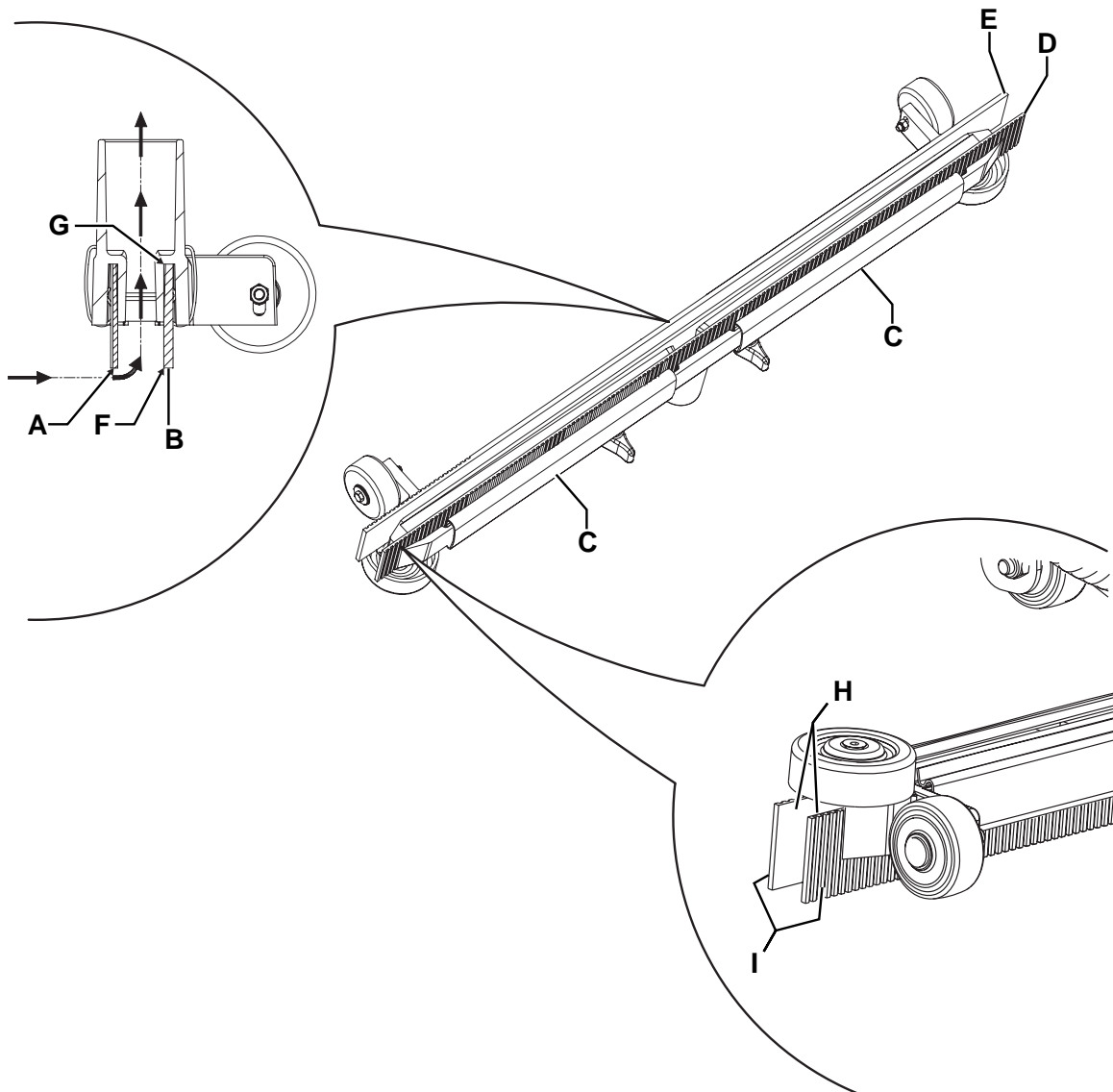

## Troubleshooting

Trouble	Possible Causes	Remedy
The recovery water vacuuming is insufficient or there is no vacuuming	The squeegee or the vacuum hose is clogged or damaged	Clean/repair/replace
	There is debris under the blade	Remove
	The squeegee blade edges are torn or worn	Replace
	The gas spring is not efficient	Replace

## Removal and Installation

### Gas Spring Disassembly/Assembly

#### Disassembly

1. If possible, place the machine on a hoisting system (or on a floor with a suitable step), in order to fully stretch the gas spring (A) of the squeegee support system (B), beyond the support base of the machine (as shown in the figure).

Make sure that the machine cannot move independently.

2. Turn the machine program selection knob to “0”.
3. Remove the squeegee as shown in Squeegee Cleaning paragraph.
4. Lower the squeegee support system (B) by fully stretching the gas spring (A).
5. Unscrew the nut (C) and remove the relevant screw.

Lower the gas spring (A) and the linkage (D).

6. Unscrew and remove the screw with nut (E).
7. Retrieve the gas spring (F).

#### Assembly

8. Assemble the components in the reverse order of disassembly.

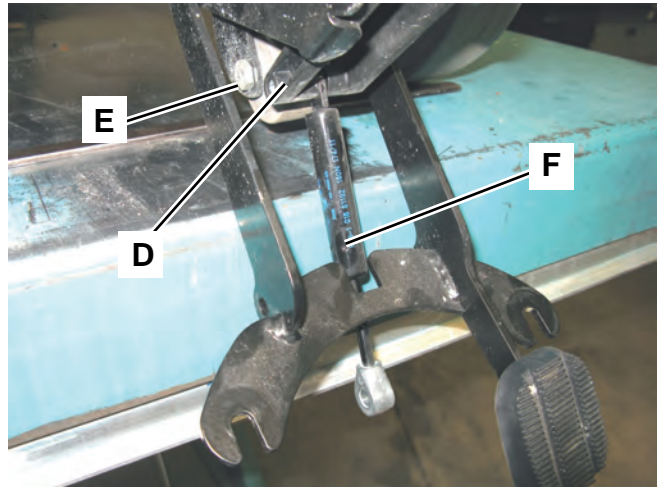
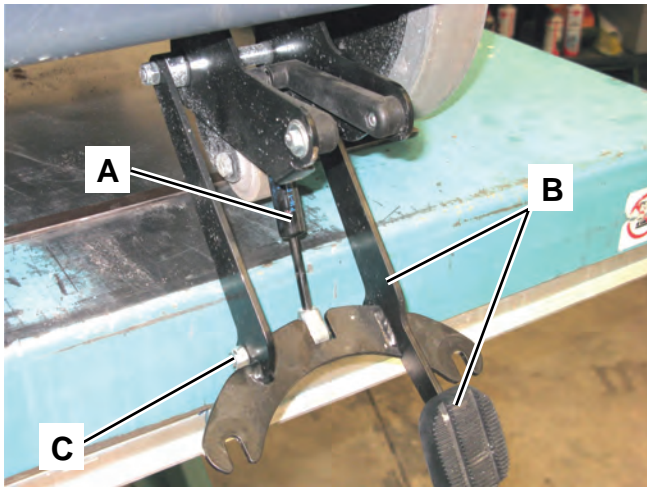

## Specifications

General	Values
Machine width with squeegee	28.3 in (720 mm)
Gas spring pressure	40,5 Lb (180 Nm)

# Wheel System, Non-Traction

## Component Locations

- Central wheels on fixed axle
- Rear support wheel, when the squeegee is lifted
- Parking wheel
- Parking wheel positioning pin

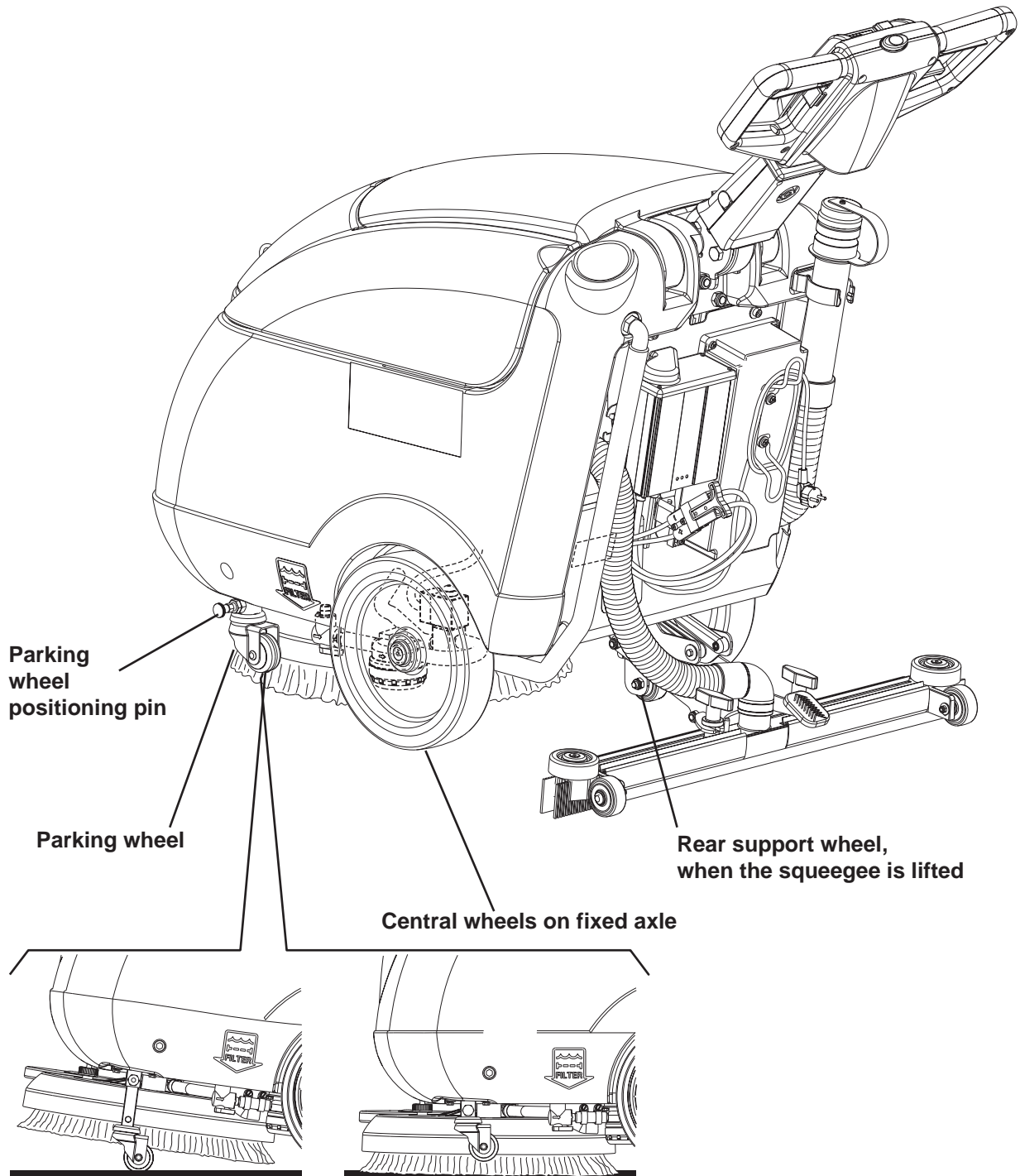

## Specifications

General	Values
Minimum turning radius	29.5 in (750 mm)
Diameter of wheels on fixed axle	9.8 in (250 mm)
Wheel pressure on the floor	290 psi (2 N/mm <sup>2</sup> )