



Electronic Service Manuals

This electronic document is provided as a service to our customers. We do not create the contents of the information contained in this document. Should you have detailed questions pertaining to the information contained in this document, you may contact Michco, or the manufacturer which provided the original information in this electronic deliverable. Michco's only part in this electronic deliverable was the electronic assembly process. By providing this manual on line we are not guaranteeing parts availability.

You may contact Michco through the following methods:

Phone (517) 484-9312 or (800) 331-3339

2011 N. High St. -- Lansing, Michigan -- 48906

Fax: (517) 484-9836

Email: CustServe@Michco.com

Web site: www.Michco.Com

Parts Web site: www.FloorMachineParts.Com

Order Parts on Line at:

www.FloorMachineParts.Com

Directly to Parts & Service:

By Email: **Shop@Michco.com**

By Fax: (517) 702-2041

By Voice: Use numbers above.

Serving the Cleaning Industry Since 1922

Notice: All copyrighted material remains property of original owners, all trademarks are property of respective owners. Manuals are subject to Manufacturer's reproduction limitations. Originals or reproductions were provided by manufacturers through a request. We make no warranty as to the correctness of information provided in this document and you assume all risk. By placing these manuals on line we are not declaring our corporation to be an manufacturer authorized dealer or provider, please check our web site for authorized manufacturers we represent.

SC351



PARTS LIST

Advance model: 9087342020

TABLE OF CONTENTS

ENG	PAGE
GENERAL VIEW	2 - 3
COVER AND TANKS	4 - 5
FRAME SYSTEM	6 - 7
HANDLE SUPPORT SYSTEM	8 - 9
HANDLE BAR SYSTEM	10 - 11
MOTOR AND DECK SYSTEM	12 - 13
BRUSH DECK SYSTEM	14 - 15
ACCESSORIES	16 - 17
ELECTRICAL DIAGRAM	18 - 19
RECOMMENDED SPARE PARTS	20
OPTIONALS AND ACCESSORIES	21

WHEN ORDERING PARTS

- * Use the part numbers from the "Ref. No." columns in this parts list.
- * Specify the model and serial number of the machine.
- * Use the space below to record the model and serial number for future reference.

Model

Serial No.

* = Optional

= Modified item No. or New item No.

[] = Not shown

GENERAL VIEW

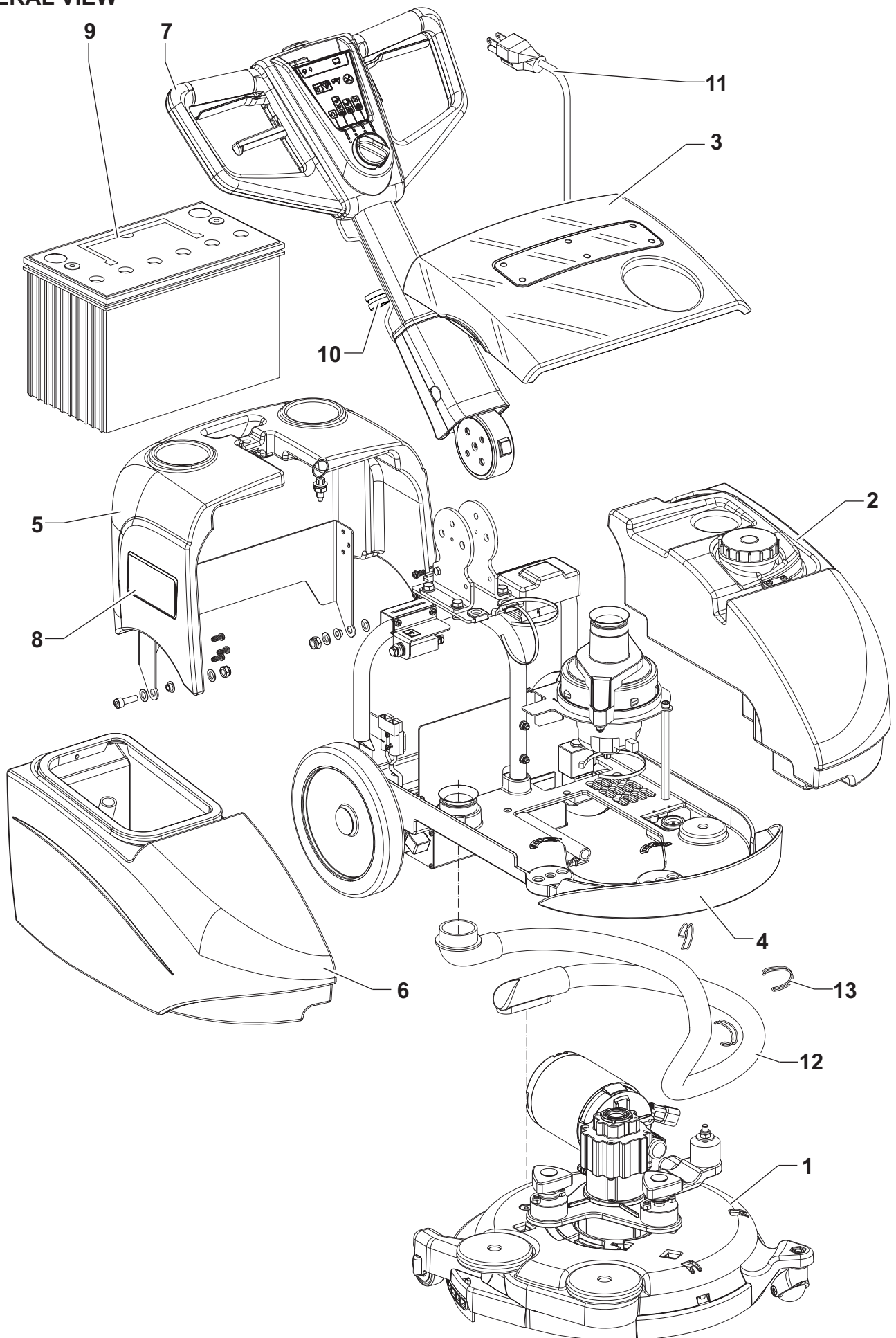

GENERAL VIEW

KIT	ITEM	REF. NO.	QTY	DESCRIPTION
	1	-	1	BRUSH DECK
	2	-	1	SOLUTION TANK
	3	-	1	COVER TANK
	4	-	1	FRAME
	5	-	1	BATTERY COVER
	6	-	1	RECOVERY TANK
	7	-	1	HANDLE
	8	9100000080	1	DECALS ADVANCE SC351 KIT
	9	1464853000	1	BATTERY 12V 84AhC5 AGM
	10	9099301000	1	HARDWARE GENERAL VIEW KIT
	11	9096914000	1	CABLE EXTENSION US
	12	9099706000	1	VACUUM PIPE D.25
	13	9098991000	1	RINGS SPRING KIT

COVER AND TANKS

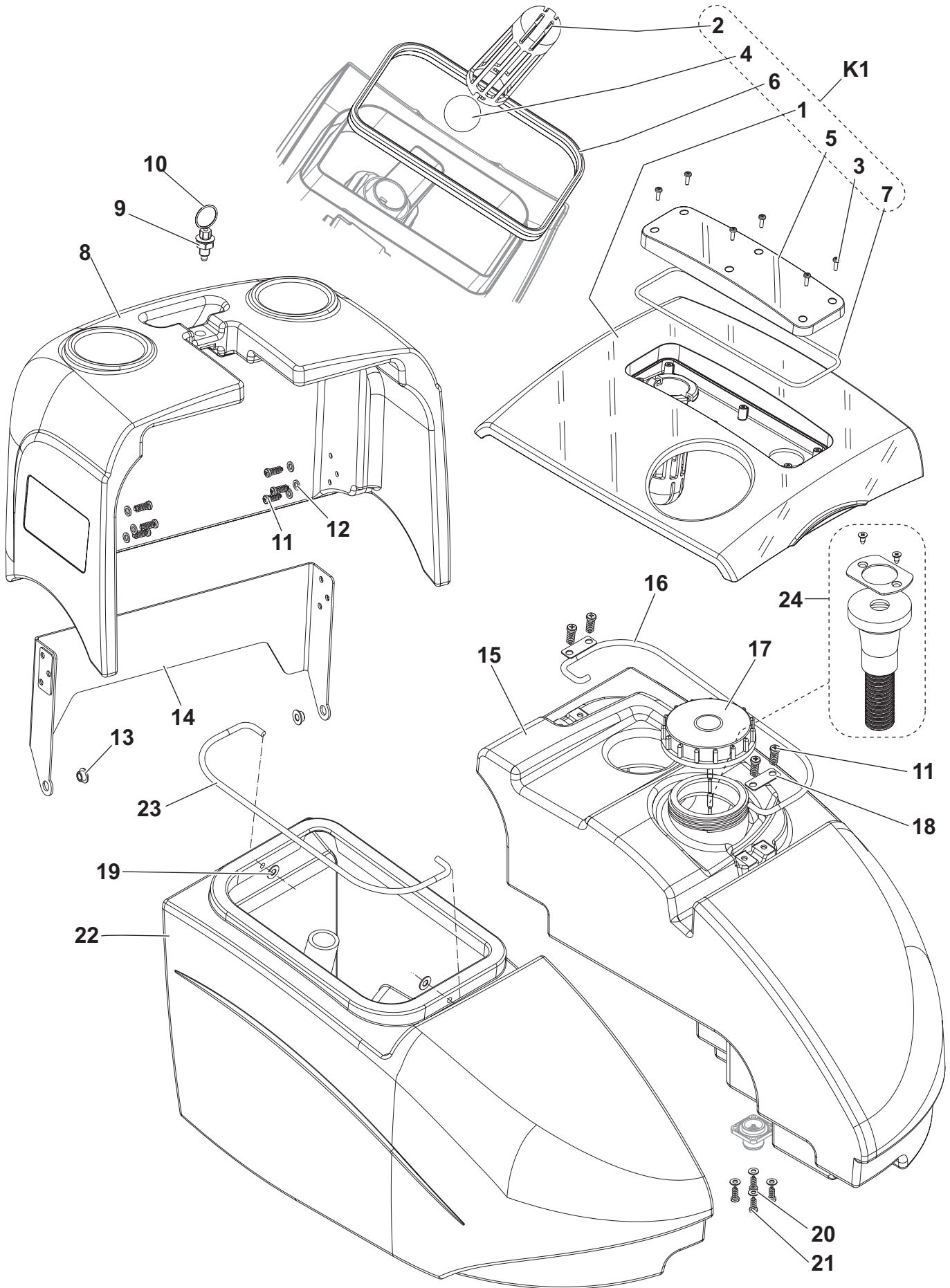

COVER AND TANKS

KIT	ITEM	REF. NO.	QTY	DESCRIPTION
K1	1		1	COVER TANK
K1	2		1	CAGE FLOAT
K1-K2	3		6	SCREW 3.5X10 THD FORMING
K1	4		1	BALL FLOATING
K1	5		1	CAP TANK COVER
K1	6	9099127000	1	GASKET TANK COVER KIT
K1	7		1	GASKET MOUSSE D.4MM
	8	9098318000	1	BATTERY COVER
	9	145 1147 000	1	WASHER 10,2X18,8X0,35
	10	146 2449 000	1	PLUNGER INDEXING
K2	11		10	SCREW CYL HD 5X16 SELF L.
K2	12		6	WASHER
K2	13		2	BUSH
	14	9098309000	1	SUPPORT BATTERY COVER
	15	9098149000	1	TANK SOLUTION RAL 7001
	16	9100000104	1	HANDLE DETERGENT TANK
	17	9099155000	1	CAP THREADED 70X5
	18	9098621000	2	PLATE HANDLE TANK
	19	9098473000	2	COVER PIN
K2	20		4	WASHER M4 UNI6592
K2	21		4	SCREW 3.5X12
	22	9098148000	1	TANK RECOVERY RAL 7001
	23	9100000103	1	HANDLE RECOVERY TANK
	24*	9099011000	1	HOSE FILLING KIT
	K1	9098989000	1	COVER KIT
	[K2]	9098990000	1	HARDWARE COVER AND TANKS KIT

FRAME SYSTEM

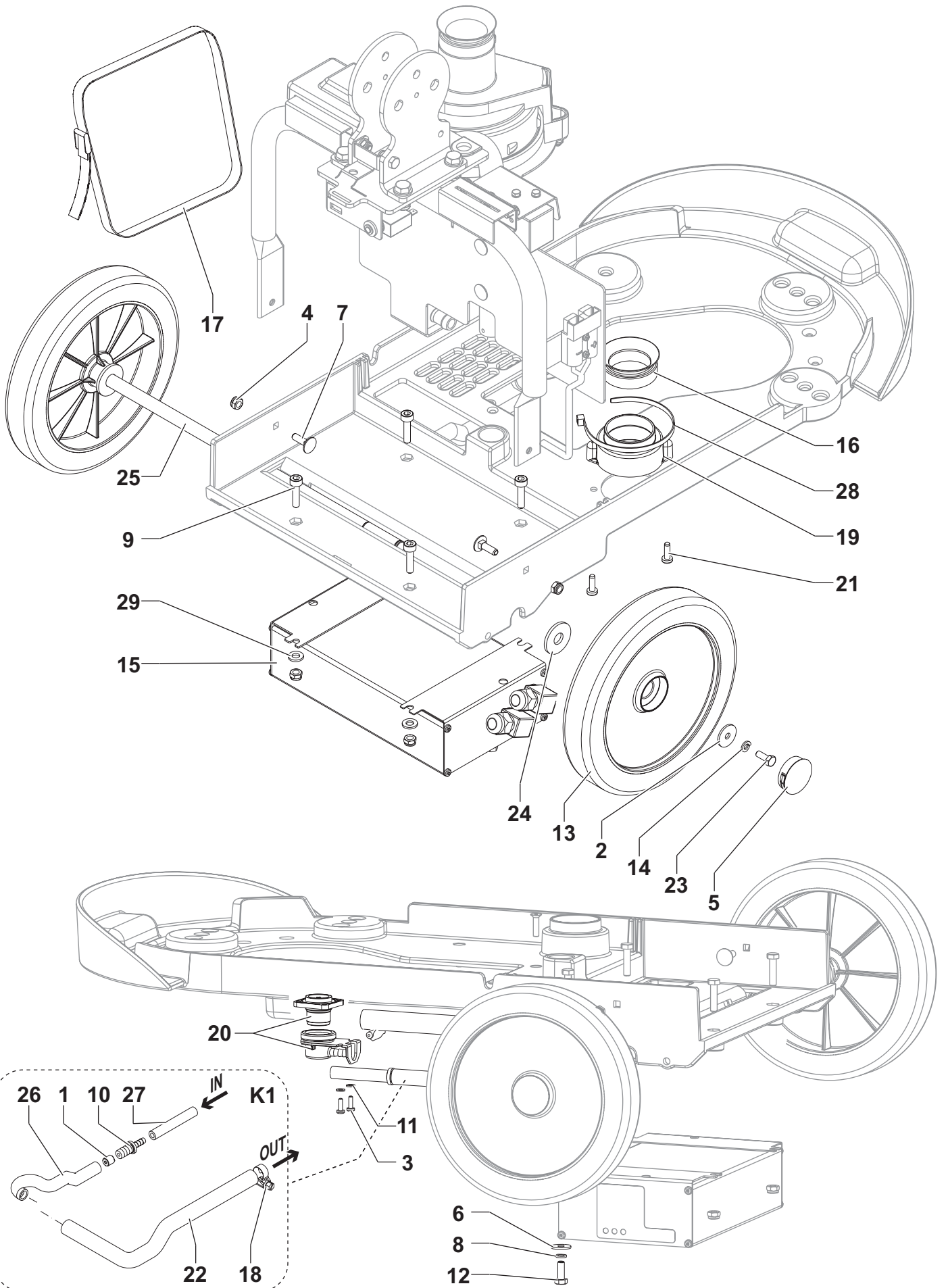

FRAME SYSTEM

KIT	ITEM	REF. NO.	QTY	DESCRIPTION
K1	1		1	REDUCTION WATER
K2	2		2	WASHER FLAT XL 6.6X24.0X2.0
K2	3		2	SCREW, PAN PHIL THD FORM PU 3.9X9.5
K2	4		3	NUT SELF L. M6 UNI7474 SS
K2	5		2	PLUG BLACK CLICK d.38.1
K2	6		2	WASHER 6X18 UNI6592
K2	7		2	SCREW M6X20 UNI5731
K2	8		3	WASHER
K2	9		4	SCREW SOC. HD M5X30
K1	10		1	FITTING
K2	11		2	WASHER, EXT. SHPRF Ø 4 SS
K2	12		2	SCREW
	13	9099732000	2	WHEEL Ø214
K2	14		2	WASHER, SPLIT LOCK d.6
	15	9099794000	1	CHARGER BATTERY 12V 12A (CH)
	16	9098319000	1	GASKET
	17	146 3054 000	1	BELT BATTERY FIXING
K1	18		1	CLAMP
	19	9099719000	1	SUPPORT FOR GASKET
	20	9098697000	1	VALVE WATER COMPLETE
K2	21		2	SCREW THREAD ROLLING 5x16
K1	22		1	HOSE D.12 L=500 MM
K2	23		2	SCREW, HEX THD TO HD M6x16
K2	24		2	WASHER 12.5X34X3 NYLON
	25	9099352000	1	PIN WHEEL
K1	26		1	HOSE D. 12
K1	27		1	PIPE 6X11
K2	28		1	CLAMP 290X4.8
K2	29		4	WASHER FLAT XL 5.5X15.0X1.6 SS
	K1	9098992000	1	PIPES KIT
	[K2]	9100000083	1	HARDWARE FRAME KIT

HANDLE SUPPORT SYSTEM

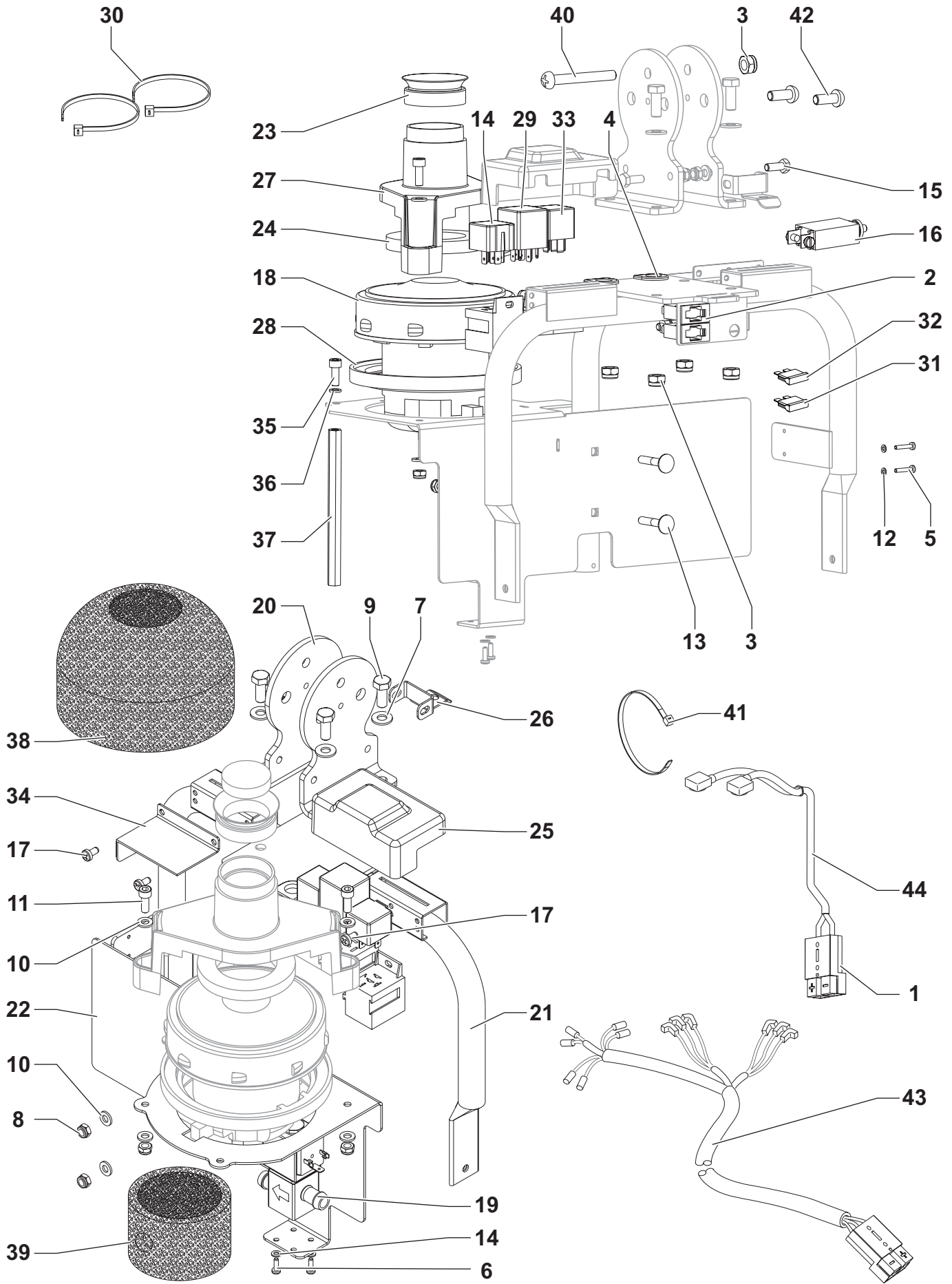

HANDLE SUPPORT SYSTEM

KIT	ITEM	REF. NO.	QTY	DESCRIPTION
	1	9098760000	2	CONNECTOR 50A GREY
	2	9098924000	2	FUSE HOLDER
K1	3		5	NUT SELFLOCKING LOW M8 UN
	4	909 6542 000	2	GROMMET
K1	5		2	SCREW M3X16 UNI7687
K1	6		3	SCREW 3.5X10 THD FORMING
K1	7		4	WASHER M8 UNI6592 SS
K1	8		8	NUT SELF L. M6 UNI7474 SS
K1	9		4	SCREW M8X20 UNI5739 SS
K1	10		8	WASHER M6 UNI6592 SS
K1	11		2	SCREW SOC. HD M6X16
K1	12		2	WASHER, EXT. SHPRF Ø 3 SS
K1	13		2	SCREW, CARRIAGE M6x35
	14	9098441000	1	RELAY 12V (K2)
K1	15		2	SCREW, HEX THD TO HD M6x16 SS
	16	9099802000	1	BREAKER CIRCUIT 35A (F1)
K1	17		4	SCREW M5X10 DIN7500
	18	9098111000	1	MOTOR VACUUM 12V 200W (M2)
	19	9098112000	1	SOLENOID VALVE 12V (EV)
	20	9098185000	2	BRACKET HANDLE
	21	9098267000	1	SUPPORT HANDLE
	22	9098268000	1	SUPPORT VACUUM MOTOR
	23	9098319000	1	GASKET
	24	9098327000	1	GASKET VACUUM MOTOR
	25	9098365000	1	COVER RELAY
	26	9098482000	1	BRACKET PLUNGER BLOCK
	27	9098483000	1	COVER VACUUM MOTOR
	28	9098554000	1	GASKET VACUUM MOTOR
	29	9098375000	1	TIMER CYCLICAL (KT1)
K1	30		2	CLAMP
	31	145 8513 000	1	FUSE BLADE 30A UL (F2)
	32	145 9852 000	1	FUSE 5A (F3)
	33	146 3113 000	1	RELAY 12V (K1)
	34	9099731000	1	CIRCUIT BRAKE SUPPORT
K1	35		2	SCREW M6X12 UNI5931 SS
K1	36		3	WASHER, EXT. SHPRF Ø 6 SS
	37	9098559000	1	SPACER SUPPORT VACUUM MOTOR
	38	9098656000	1	CASING VACUUM MOTOR
	39	9098925000	1	CASING LOWER VACUUM MOTOR
K1	40		1	SCREW, BUTTON SOC M8X55
K1	41		4	CLAMP
K1	42		2	SCREW, BUTTON SOC M 10X25 SS
	43	9099330000	1	HARNESS MACHINE
	44	9098849000	1	HARNESS BATTERY
	[K1]	9100000084	1	HARDWARE HANDLE BAR SUPP. KIT

HANDLE SYSTEM

KIT	ITEM	REF. NO.	QTY	DESCRIPTION
K3	1		3	WASHER
	2	L08603153	1	SWITCH PUMP (SW3)
	3	L08603154	1	CAP PROTECTION
K5	4		2	WASHER 6X18X1.5 UNI6593
K5	5		2	SCREW M3X8 UNI7688
K5	6		1	CLAMP 290X4.8
K5	7		2	WASHER
K5	8		2	CLAMP
K5	9		2	SCREW 3.9X9.5 UNI6955
K5	10		2	INSERT M6X15 UNI9203
	11	146 3073 000	1	BOARD. LED (EB1)
K5	12		2	SCREW M6X16 UNI7687 SS
	13	909 5149 000	1	SUPPORT CABLE
	14	9097283000	1	KNOB CONTROL FUNCTIONS
K5	15		1	SCREW GRUB M3X3 DIN916
K5	16		2	SCREW 2.9X25 UNI6954 THD
K5	17		1	SEAL O-RING
	18	9099331000	1	HARNESS HANDLE BAR
	19	9099332000	1	SWITCH ROTATIVE 4 POSITIONS (SW1)
	20	9100000101	1	COVERS HANDLE GREY KIT
	21	9099733000	1	DECAL CONTROL PANEL
	22	9098616000	1	DECAL BATTERY LED
	23	9098812000	1	CAP FOR HANDLE
	24	9098813000	1	CAP D.18.5/D.40MM BLACK
	25	9098835000	1	TUBE HANDLE
	26	9098836000	1	ROD INDEX
K4	27		2	LEVER SWITCH
K4	28		1	LEVER
K1	29		1	CAP RUBBER
K1	30		1	COVER REAR
K1	31		1	COVER FRONT
K4	32		1	BUTTON INTERLOCK
	33	VF47033	1	RETAINER
	34	VF54041	1	HANDLE PLUG
	35	40263A	1	SWITCH DPDT (SW2)
K4	36		1	SPRING INTERLOCK BUTTON
K2	37		1	SPRING COMPRESSION
K2	38		1	GEAR
K2	39		1	HOUSING GEAR INDEX
K4	40		1	CLAMP CORD
K4	41		4	PIN HANDLE SUPPORT
K2	42		1	GEAR INDEX
K3	43		1	HANDLE SUPPORT
K2	44		2	PLATE, GEAR HOUSING
K4	45		2	SCREW M3X25
K1	46		4	SCREW ST4.2-1.4
K3	47		1	SCREW M5X43
K3	48		1	NUT LOCK M5 SS HEX
K4	49		1	NUT LOCK M4 SS HEX
K2	50		4	NUT LOCK M6 SS HEX
K3	51		1	SCREW M5X40 SS PAN HEAD PHILLIPS
K5	52		2	SCREW M4X8 UNI7688
K4	53		3	SCREW M4X10 SS PAN HEAD PHILLIPS
K3	54		6	SCREW M5X12 TRUSS HEAD PHILLIPS
K2	55		4	SCREW M6X40 SS HEX HEAD
	56	80398A	2	SCREW M5x35 SS HEAD PHILLIPS
	57	VV13609	1	NUT LOCK M6 SS HEX
	58	80407A	4	SCREW M5X25 SS FLAT HEAD PHILLIPS
K1	11271A		1	LOWER COVER KIT
K2	11272A		1	BOX HOUSING GEARS KIT
K3	11273A		1	HANDLE SUPPORT KIT
K4	11274A		1	HANDLE SWITCH LEVER KIT
K5	9098995000		1	HARDWARE HANDLE BAR KIT

MOTOR AND DECK SYSTEM

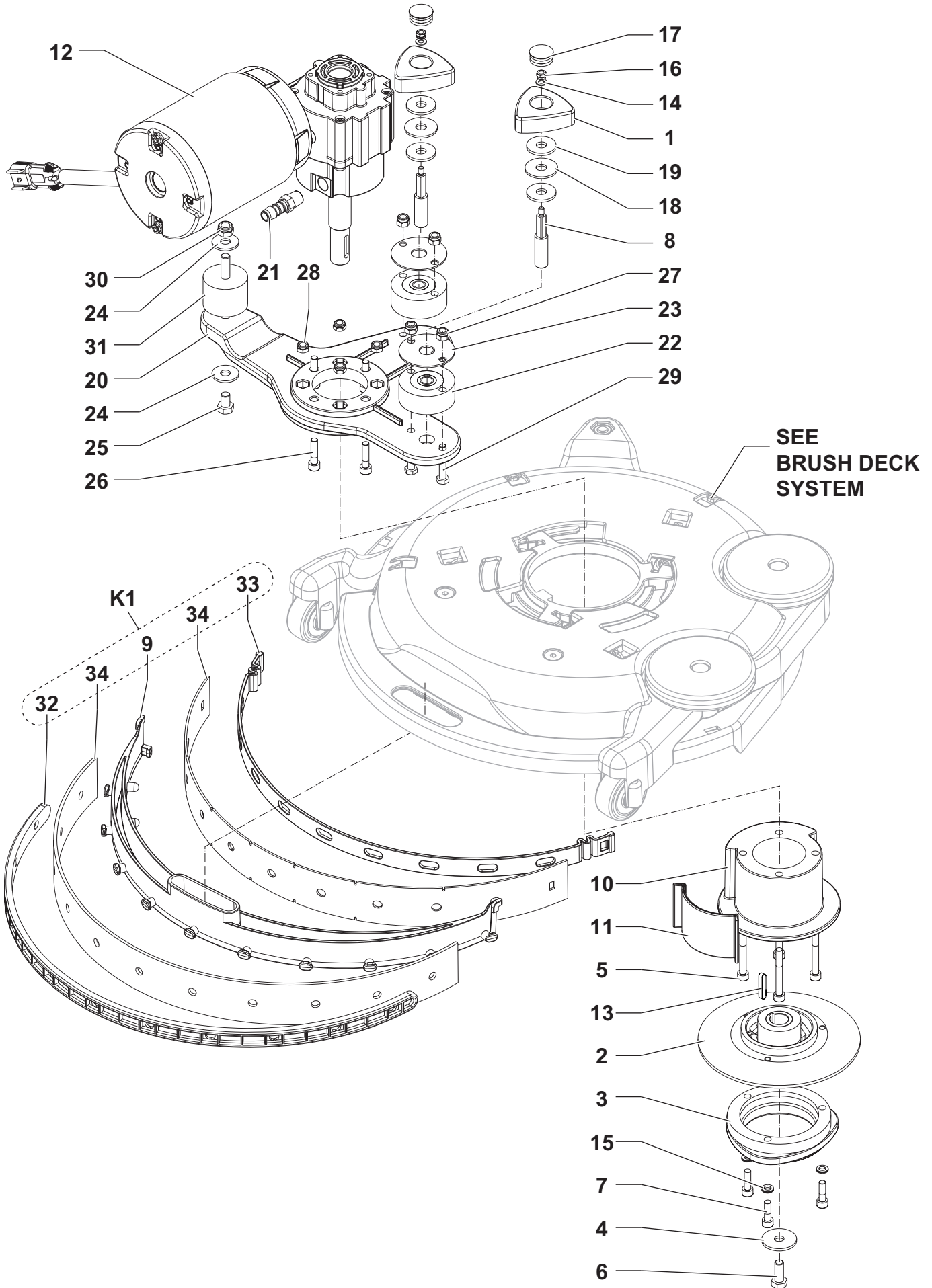

MOTOR AND DECK SYSTEM

KIT	ITEM	REF. NO.	QTY	DESCRIPTION
	1	L08812203	2	KNOB
	2	L08812306	1	HOUB.BRUSH R.GEARMOTOR RIGHT
	3	L08812480	1	HUB, BRUSH
K2	4		1	SCREW, HEX THD TO HD M8x20 SS
K2	5		4	SCREW SOC. HD M6X50
K2	6		1	WASHER FLAT XL 9.0X32.0X2.5 SS
K2	7		3	SCREW SOC. HD M6x20 SS
	8	9098557000	2	PIN, BRUSH PLATE FIXING
K1	9		1	SQUEEGEE
	10	9099717000	1	FLANGE DECK
	11	9099736000	1	SPACER LIMIT
	12	9099181000	1	REDUCTION MOTOR GEAR 12V 260W (M1)
	13	145 8024 000	1	KEY 5X 5X25
K2	14		2	WASHER, FLAT 5.3x10x1 SS
K2	15		3	WASHER NORD LOCK M6
K2	16		2	NUT, HEX NYL LOC THIN M5 SS
	17	L08812426	2	CAP
K2	18		2	WASHER FLAT XL 10X30X2 - RUBBER
K2	19		4	WASHER FLAT 9,5X27X2.5
	20	9099718000	1	SUPPORT DECK
	21	L08601624	1	HOLDER RUBBER 1/4 D.10
	22	L08812213	2	SHOCK ABSORBER
	23	L08812779	2	PLATE, VIBRATION DAMPING
K2	24		2	ROND GREMB 8X24
K2	25		1	SCREW, HEX THD TO HD M8x12
K2	26		4	SCREW SOC. HD M6X25 SS
K2	27		4	NUT, HEX NYL LOC HVY M6
K2	28		4	NUT, HEX NYL LOC THIN M6
K2	29		4	SCREW, HEX THD TO HD M6x35 SS
K2	30		1	NUT, HEX NYL LOC THIN M8 SS
	31	9097184000	1	SHOCK ABSORBER 40x30 M8 TYPE EI - 60 Sh
K1	32	9099707000	1	REAR STRAP ELASTIC
K1	33	9099708000	1	RUBBER BLADE RETAINER
K1	34	9100000077	1	BLADES SQUEEGEE KIT
	K1	9100000085	1	SQUEEGEE KIT
	[K2]	9100000086	1	HARDWARE MOTOR AND DECK KIT

BRUSH DECK SYSTEM

KIT	ITEM	REF. NO.	QTY	DESCRIPTION
	1	L08603665	2	WHEEL D51 SQUEEGEE
K2	2		2	SCREW FLAT SOCKET HEAD M8X20.0
K2	3		2	NUT, HEX THIN M6
K2	4		2	SCREW, CARRIAGE M6x25
K2	5		2	WASHER FLAT XL 6.6X24.0X2.0
K2	6		1	NUT, HEX NYL LOC THIN M10
K2	7		4	THREAD ROLLING SCR 5x16
K2	8		2	PIN D.8
	9	9099163000	1	CASTOR WHEEL \varnothing 42
	10	9099712000	1	COVER BRUSH DECK
	11	9099713000	1	FLANGE CENTRAL
K1	12		2	CLUTCH SUPPORT
K1	13		2	CLUTCH
	14	9100000040	1	COUNTERWEIGHT
	15	9099720000	3	SPRING TRACTION
	16	30048A	2	GUIDE, WHEEL
K2	17		2	WASHER 15
	K1	9100000087	1	CLUTCH KIT
	K2	9100000088	1	HARDWARE BRUSH DECK KIT

ACCESSORIES

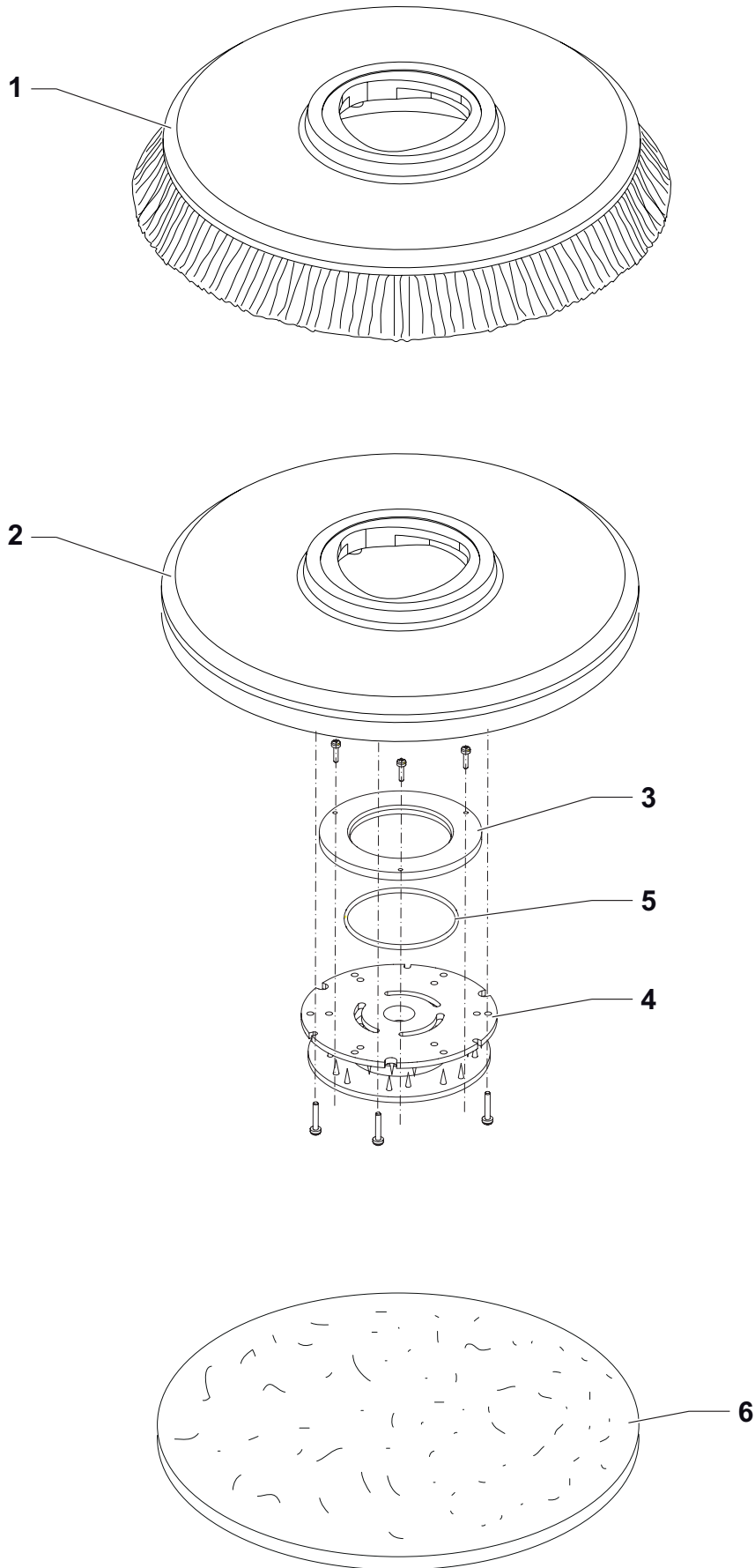

ACCESSORIES

KIT	ITEM	REF. NO.	QTY	DESCRIPTION
	1	9099999000	1	BRUSH D.370MM 14" PROLENE PPL
	1*	9100000001	1	BRUSH D.370MM 14" PROLITE PPL
	1*	9100000000	1	BRUSH D.370MM 14" UNION MIX
	1*	9100000002	1	BRUSH D.370MM 14" MID GRIT 240
	1*	9100000003	1	BRUSH D.370MM 14" MIDLITE GRIT 180
	2*	9099672000	1	PAD HOLDER GRIP 14"
	3	L08603966	1	RING NYLON
	4	L08837030	1	RETAINER PAD
	5	L08603965	1	SEAL O-RING
	6*	10001918	1	PAD 14 355MM BROWN 5 PCS
	6*	10001920	1	PAD 14 355MM RED 5 PCS
	6*	10001921	1	PAD 14 355MM WHITE 5 PCS
	6*	10001919	1	PAD 14 355MM GREEN 5 PCS

WIRING DIAGRAM

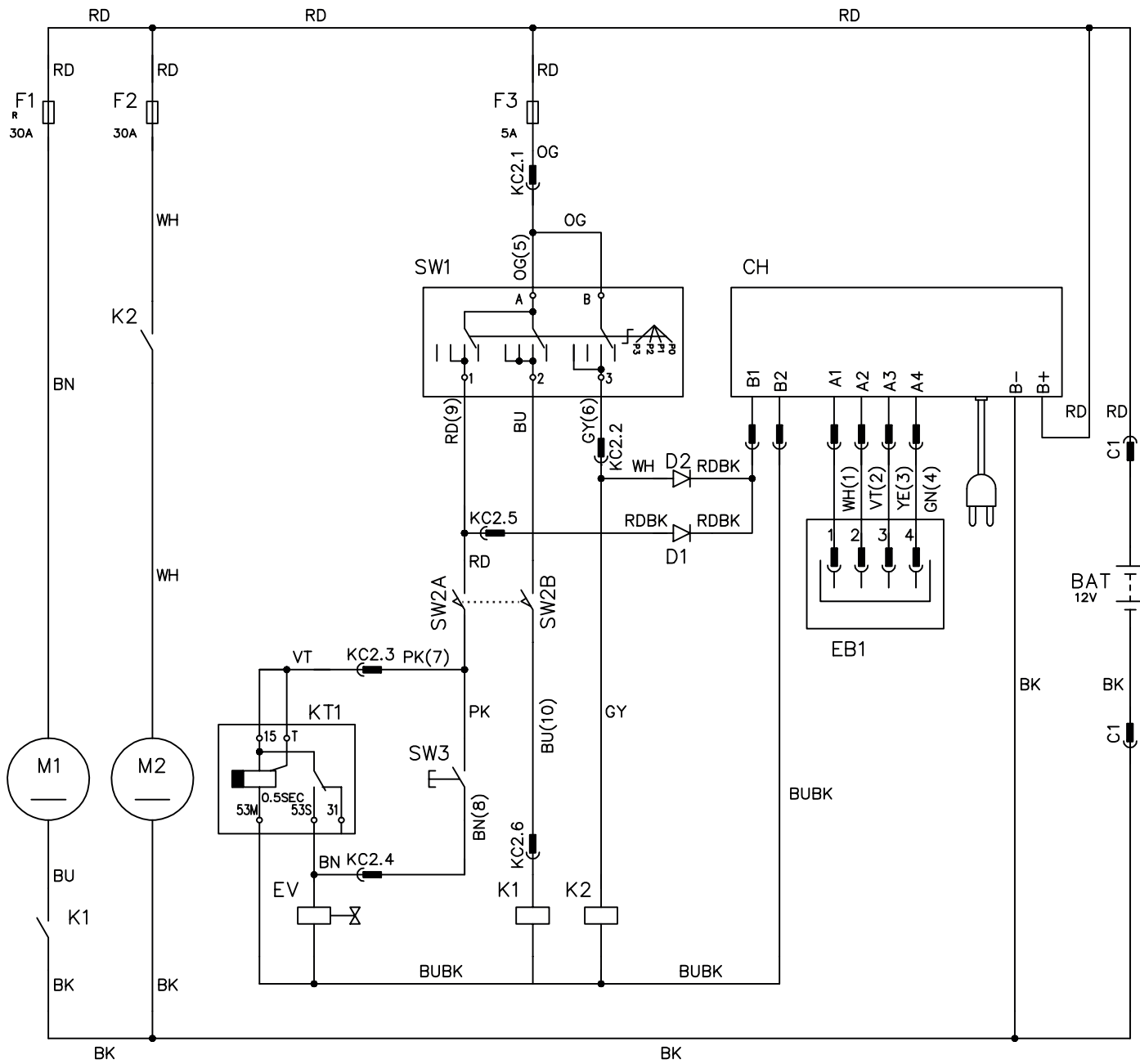

WIRING DIAGRAM

KEY	REF. NO.	DESCRIPTION
BAT	1464853000	BATTERY 12V 84AhC5 AGM
CH	9099794000	BATTERY CHARGER
D1	-	DIODE
D2	-	DIODE
EB1	146 3073 000	BATTERY LEVEL BOARD
EV	9098112000	DETERGENT SOLENOID VALVE
F1	9099802000	BRUSH MOTOR CIRCUIT BREAKER (35 A)
F2	145 8513 000	VACUUM MOTOR FUSE (30 A)
F3	145 9852 000	ROTATIVE SWITCH FUSE (5 A)
K1	146 3113 000	BRUSH MOTOR RELAY
K2	9098441000	VACUUM MOTOR RELAY
KT1	9098375000	SOLENOID VALVE TIMER
M1	9099181000	BRUSH MOTOR
M2	9098111000	VACUUM MOTOR
SW1	9099332000	ROTATIVE SWITCH
SW2	40263A	SWITCH BRUSH MOTOR-SOLENOID VALVE
SW3	L08603153	DETERGENT SWITCH

KEY	COLOUR
BK	BLACK
BU	LIGHT BLUE
BN	BROWN
GN	GREEN
GY	GREY
OG	ORANGE

KEY	COLOUR
PK	PINK
RD	RED
VT	VIOLET
WH	WHITE
YE	YELLOW

RECOMMENDED SPARE PARTS

REF. NO.	QTY	DESCRIPTION
		NORMAL WEAR
910000077	1	BLADES SQUEEGEE KIT
9099999000	1	BRUSH D.370MM 14" PROLENE PPL
		ORDINARY MAINTENANCE
9099707000	1	REAR STRAP ELASTIC
9099708000	1	RUBBER BLADE RETAINER
9099127000	1	GASKET TANK COVER KIT
9098319000	2	GASKET
9098111000	1	MOTOR VACUUM 12V 200W (M2)
9098327000	1	GASKET VACUUM MOTOR
9098655000	1	FILTER VACUUM MOTOR
9099181000	1	REDUCTION MOTOR GEAR 12V 260W (M1)
L08812480	1	HUB.BRUSH
9099706000	1	VACUUM PIPE D.25
L08603665	2	WHEEL D51 SQUEEGEE
9099163000	1	CASTOR WHEEL ø42
910000087	1	CLUTCH KIT
910000085	1	SQUEEGEE KIT
		EXTRA-ORDINARY MAINTENANCE
9099712000	1	COVER BRUSH DECK
30048A	2	GUIDE, WHEEL
9099732000	2	WHEEL Ø214
9099794000	1	CHARGER BATTERY 12V 12A (CH)
9098697000	1	VALVE WATER COMPLETE
9098992000	1	PIPES KIT
9098760000	2	CONNECTOR 50A GREY
9099802000	1	BREAKER CIRCUIT 35A (F1)
9098112000	1	SOLENOID VALVE 12V (EV)
146 3113 000	1	RELAY 12V (K1)
9098441000	1	RELAY 12V (K2)
9098375000	1	TIMER CYCLICAL (KT1)
145 8513 000	1	FUSE BLADE 30A UL (F2)
145 9852 000	1	FUSE 5A (F3)
9099332000	1	SWITCH ROTATIVE 4 POSITIONS (SW1)
40263A	1	SWITCH DPDT (SW2)
L08603153	1	SWITCH PUMP (SW3)

OPTIONALS AND ACCESSORIES

	REF. NO.	QTY	DESCRIPTION
	9099011000	1	HOSE FILLING KIT
	9100000001	1	BRUSH D.370MM 14" PROLITE PPL
	9100000000	1	BRUSH D.370MM 14" UNION MIX
	9100000002	1	BRUSH D.370MM 14" MID GRIT 240
	9100000003	1	BRUSH D.370MM 14" MIDLITE GRIT 180
	9099672000	1	PAD HOLDER GRIP 14"
	10001918	1	PAD 14 355MM BROWN 5 PCS
	10001920	1	PAD 14 355MM RED 5 PCS
	10001921	1	PAD 14 355MM WHITE 5 PCS
	10001919	1	PAD 14 355MM GREEN 5 PCS



Advance

14600 21st Avenue North
Plymouth, MN 55447-3408

www.advance-us.com

Phone: 800-989-2235

Fax: 800-989-6566

©2013 Nilfisk-Advance, Inc.

A Nilfisk-Advance Brand