



Electronic Service Manuals

This electronic document is provided as a service to our customers. We do not create the contents of the information contained in this document. Should you have detailed questions pertaining to the information contained in this document, you may contact Michco, or the manufacturer which provided the original information in this electronic deliverable. Michco's only part in this electronic deliverable was the electronic assembly process. By providing this manual on line we are not guaranteeing parts availability.

You may contact Michco through the following methods:

Phone (517) 484-9312 or (800) 331-3339

2011 N. High St. -- Lansing, Michigan -- 48906

Fax: (517) 484-9836

Email: CustServe@Michco.com

Web site: www.Michco.Com

Parts Web site: www.FloorMachineParts.Com

Order Parts on Line at:

www.FloorMachineParts.Com

Directly to Parts & Service:

By Email: **Shop@Michco.com**

By Fax: (517) 702-2041

By Voice: Use numbers above.

Serving the Cleaning Industry Since 1922

Notice: All copyrighted material remains property of original owners, all trademarks are property of respective owners. Manuals are subject to Manufacturer's reproduction limitations. Originals or reproductions were provided by manufacturers through a request. We make no warranty as to the correctness of information provided in this document and you assume all risk. By placing these manuals on line we are not declaring our corporation to be an manufacturer authorized dealer or provider, please check our web site for authorized manufacturers we represent.

Convertamatic™

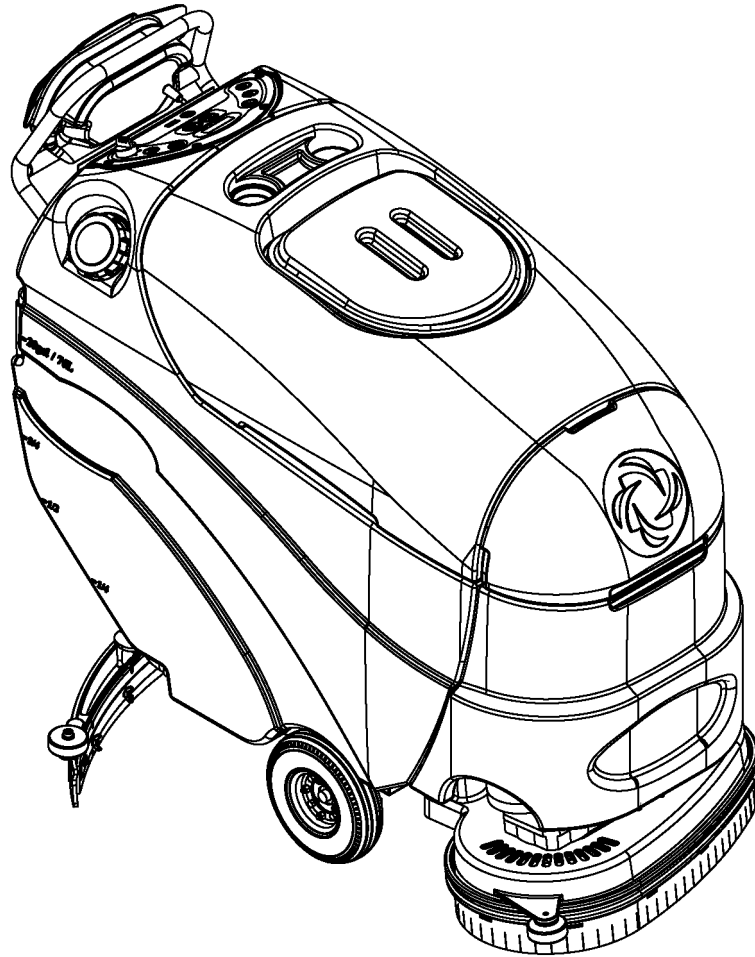

Parts List

Advance Models: 56315000(24D-C), 56315001(26D), 56315002(28D), 56315003(24C-C), 56315004(28D-C), 56315005(28C-C), 56315006(X24D-C), 56315007(X24C-C), 56315008(26D-C), 56315009(X26D-C), 56315010(26C-C), 56315011(X26C-C), 56315012(X28D-C), 56315013(X28C-C), 56315804(32D-C) 56315805(X32D-C)



Advance

DESCRIPTION	PAGE
Chassis System	2-3
Chassis System (squeegee linkage assy before SN1915725).....	4-5
Chassis System (squeegee linkage assy after SN1915724).....	6-7
Decal System.....	8-9
Recovery System.....	10-11
Scrub System-Disk (24", 26", 28")	12-13
Scrub System-Disk (32").....	14-15
Scrub System-Cylindrical.....	16-17
Solution System / Electrical-1	18-19
Solution System / Electrical-2.....	20-21
Chemical Assembly (AXP Models Only).....	22-23
Paddle Assembly	24-25
Squeegee Assembly	26-27
Wiring Diagram (before September 2009).....	28-29
Wiring Diagram (after August 2009)	30-31
Optional Kits & Accessories.....	32
Brush Selector Guide-Disk	33
Brush Selector Guide-Cylindrical.....	34

WHEN ORDERING PARTS

- * Use the part numbers from the "Ref. No." columns in this parts list.
- * Specify the model and serial number of the machine.
- * Use the space below to record the model and serial number for future reference.

Model _____ Serial No. _____

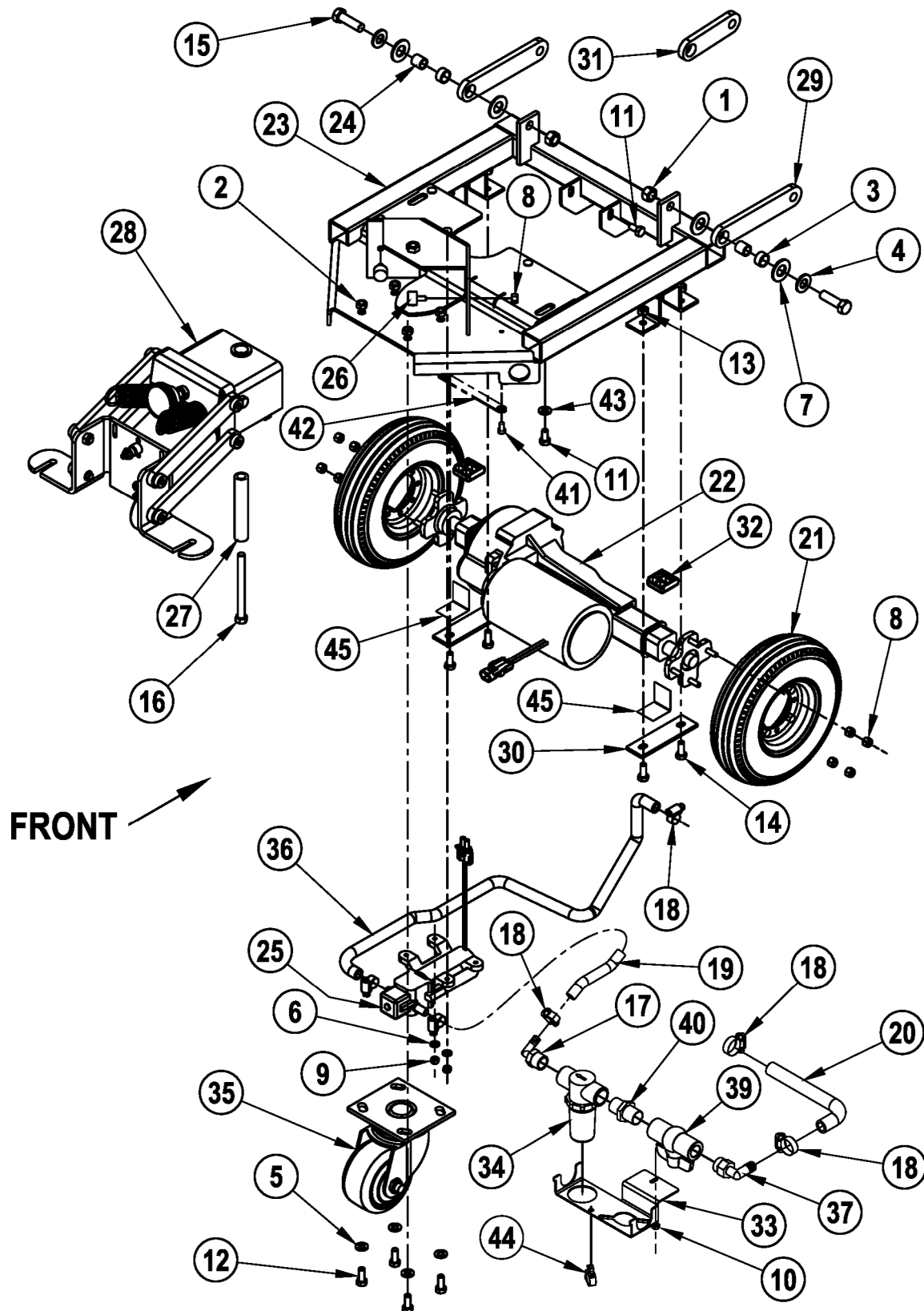

Item	Ref. No.	Qty	Description
1	56003312	2	Nut, Hex Nyl Loc M12-1.75
2	56003389	4	Nut, Hex Nyl Loc M8-1.25
3	56370878	2	Bearing, Sleeve
4	56001879	2	Wsh, Flt SAE 1/2
5	56001939	4	Wsh, Flt SAE 5/16
6	56001954	2	Wsh, Flt SAE #10
7	56002022	4	Wsh, Flt SAE 5/8
8	56002708	10	Nut, Hex Nyl Loc 1/4-20
9	56002768	2	Nut, Hex Nyl Loc 10-24
10	56002832	1	Nut, Hex Nyl Loc-Thin 10-24
11	56003012	3	Scr, Hex Hd SS 5/16-18x.75
12	56003179	4	Scr, Hex Thd To Hd M8-1.25x20mm
13	56003405	4	Nut, Hex Nyl Loc SS M8x1.25
14	56003435	4	Scr, Hex Hd SS 8-1.25x20mm
15	56003637	2	Scr, Hex M12-1.75x40mm
16	56009241	1	Scr, Hex Hd 3/8-16x4.25
17	56900033	1	Barb, 90 Elbow 3/8 X 1/2 NPT
18	56219932	6	Clamp, Hose SAE #6
19	56244991	1	Hose-PVC .38 X 15.00
20	56262180	1	Hose, Spiral .500
21	56315115	2	Wheel, Drive TSBUS2006-941
22	56315062	1	Transaxle, 24V (M1) TSBUS2008-1014
*	56315377	1	Motor
*	56315378	4	Carbon Brush
*	56315379	2	Neoprene Mounting Sleeve
*	56380497	A/R	Transaxle Kit TSBUS2008-1014
*	56380503	A/R	Transaxle Hub Kit TSBUS2008-1018
*	56380161	1	Kit-Coupling
23	56315076	1	Weldment, Chassis TSBUS2005-895
24	56315080	2	Bushing
25	56315108	1	Pump, 24VDC (M8)
26	56315111	2	Cylindrical Mount
27	56315154	1	Bushing, Spacer
28	56315165	1	Assembly, Squeegee Linkage
29	56315179	2	Linkage Arm
30	56315234	2	Plate NOTE 1
	56380499	2	Plate, Transaxle NOTE 2
31	56315239	1	Linkage Arm only used before May 2007
32	56315258	2	Shim
33#	56381476	1	Bracket, Filter Mount NOTE 4
34	56315296	1	Solution Filter
35	56365555	1	Caster Swivel 4.0 x 2.0
36	56391802	1	Hose, Spiral .375
37	56409152	1	Barb, 90 Elbow 1/2 X 1/2npt
39#	56381475	1	Ball Valve NOTE 4
40#	56381474	1	Nipple NOTE 4
41	56009030	1	Scr, Pan Phil Thd Form 10-24 x .38
42	56467544	1	Chain
43	56002220	2	Wsh, Flt STD 5/16
44	56900756	1	Clip, Conduit
45	56380496	2	Shim, Transaxle Angle NOTE 3

* = Not Shown

= Revised or new since last update

NOTE 1: Used on Convertamatic 26D before SN 2059972 and all other models before SN 2062812.

NOTE 2: Used on Convertamatic 26D after SN 2059972 and all other models after SN 2062812.

NOTE 3: Only used on machines between the following serial numbers;

Convertamatic 26D - between SN 2059972 & 2063621.

All models except Convertamatic 26D – between SN 2062812 & 2063621.

#NOTE 4: 56315260(Bracket), 56315607(Ball Valve) & 56412182(Nipple) are no longer used in production and no longer available. If you need to replace any of these items please order Ball Valve Bracket Kit 56381521.

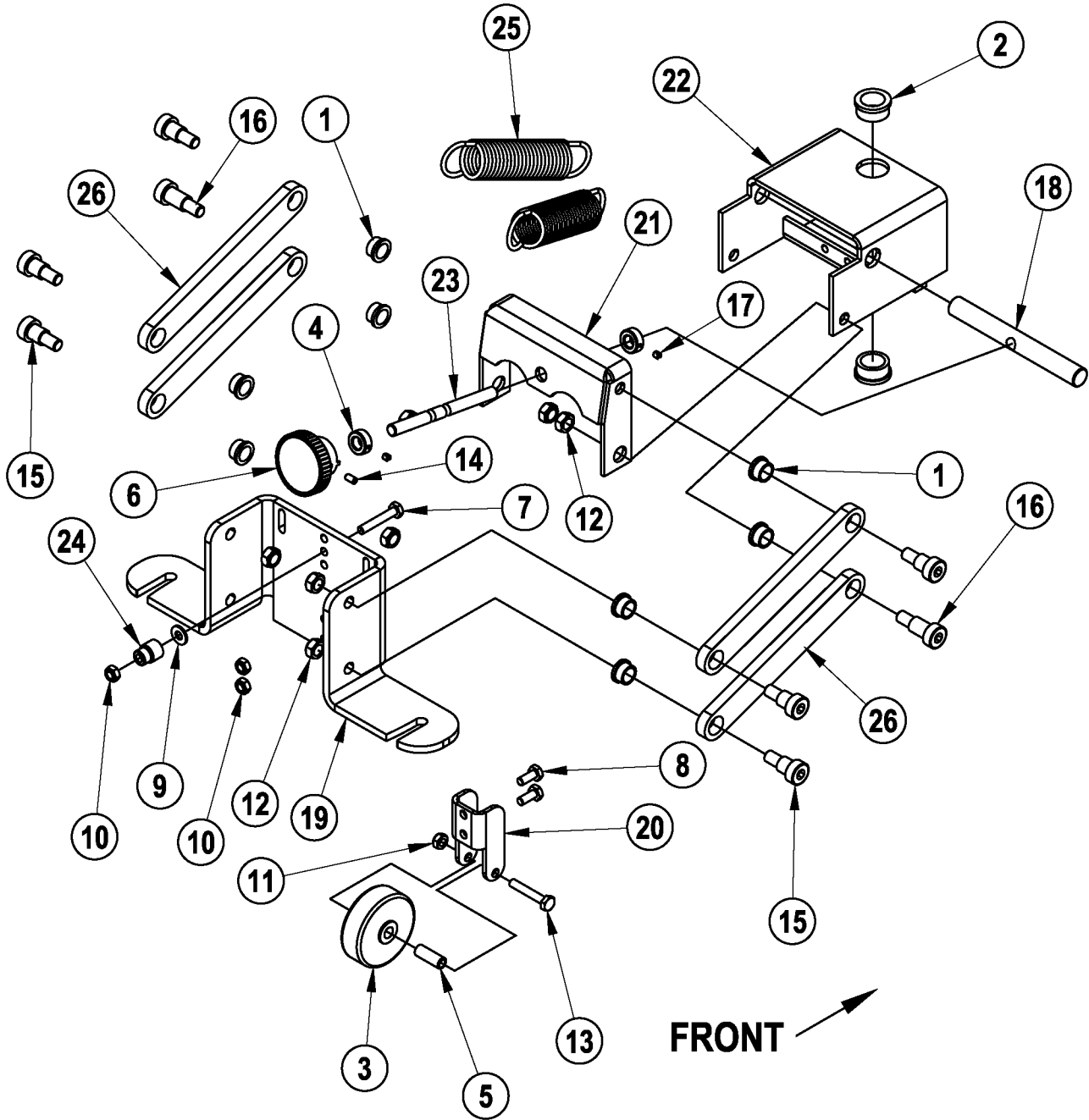

04-11

CHASSIS SYSTEM (squeegee linkage assy before SN1915725)

10-4

Convertamatic™**5**

Item	Ref. No.	Qty	Description
	56315165	1	Squeegee Linkage Assembly
1	56185264	8	Bearing, Flange
2	56250414	2	Bearing, Flange
3	56324350	1	Wheel
4	56331076	2	Collar
5	56471220	1	Bushing
6	56475480	1	Knob
7	56001833	1	Scr, Hex Hd 1/4-20x1.50
8	56001836	2	Scr, Hex Hd 1/4-20x.62
9	56002098	1	Wsh, Flt SAE 1/4
10	56002840	3	Nut, Hex Nyl Loc-Thin 1/4-20
11	56002850	1	Nut, Hex Nyl Loc-Thin SS 1/4-20
12	56002852	8	Nut, Hex Nyl Loc-Thin SS 3/8-16
13	56002880	1	Scr, Hex Loc SS 1/4-20 x 1.75
14	56003123	1	Scr, Soc Set 10-24x.38
15	56003682	6	Scr, Soc Shd .50 X .50 X 3/8-16
16	56003692	2	Scr, Soc Shd .50 X .75 X 3/8-16
17	56009084	2	Scr, Soc Set Loc 10-24x.19
18	56315082	1	Pin
19	56315151	1	Bracket, Squeegee Mount
20	56315153	1	Bracket, Wheel
21	56315180	1	Bracket, Squeegee Level
22	56315196	1	Weldment, Squeegee
23	56315240	1	Rod, Adjustment
24	56315245	1	Bushing, Squeegee Cable
25	56315295	2	Spring, Extension
26	56315338	4	Linkage Arm

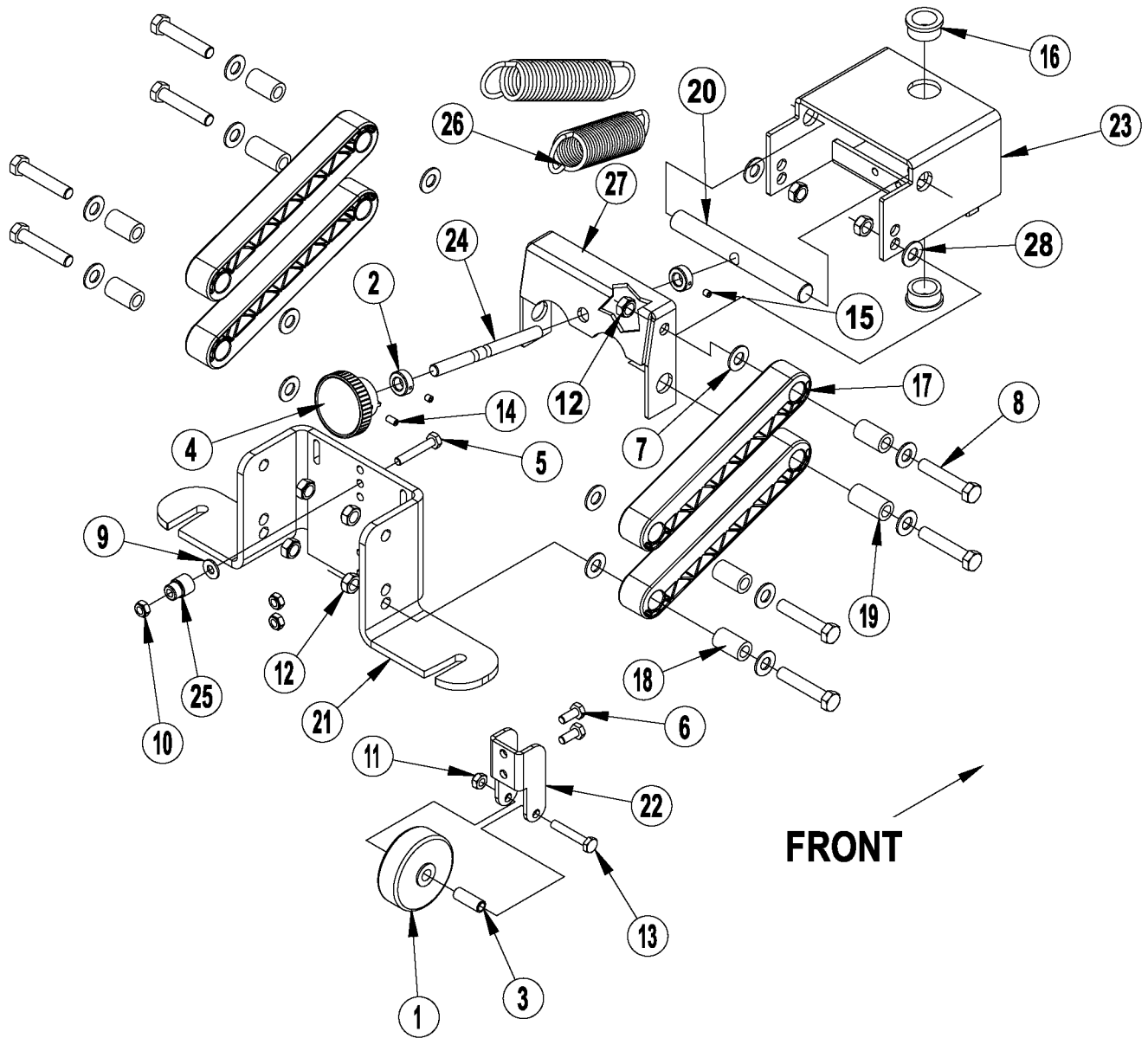

04-11

CHASSIS SYSTEM (squeegee linkage assy after SN1915724)

10-4

Convertamatic™**7**

Item	Ref. No.	Qty	Description
	56315165	1	Squeegee Linkage Assembly
1	56324350	1	Wheel
2	56331076	2	Collar
3	56315580	1	Bushing
4	56475480	1	Knob
5	56001833	1	Scr, Hex 1/4-20 X 1.50
6	56001836	2	Scr, Hex 1/4-20 X .62
7	56002063	14	Wsh, Flt SAE 3/8
8	56002091	8	Scr, Hex 3/8-16 X 2.00
9	56002098	1	Wsh, Flt SAE 1/4
10	56002840	3	Nut, Hex Nyl Loc-Thin 1/4-20
11	56002850	1	Nut, Hex Nyl Loc-Thin SS 1/4-20
12	56002852	8	Nut, Hex Nyl Loc-Thin SS 3/8-16
13	56002880	1	Scr, Hex Loc SS 1/4-20 x 1.75
14	56003123	1	Scr, Soc Set 10-2 4x .38
15	56009084	2	Scr, Soc Set Loc 10-24 X .19
16	56250414	2	Bearing, Flange
17	56315941	4	Linkage Arm, Molded
18	56315067	6	Spacer, Phenolic
19	56315068	2	Spacer, Phenolic
20	56315082	1	Pin
21	56315151	1	Bracket, Squeegee Mount
22	56315153	1	Bracket, Wheel
23	56315196	1	Weldment, Squeegee
24	56315240	1	Rod, Adjustment
25	56315245	1	Bushing, Squeegee Cable
26	56315295	2	Spring, Extension
27	56315713	1	Bracket, Squeegee Level
28	56002940	2	Wsh, Flt SAE SS 5/8

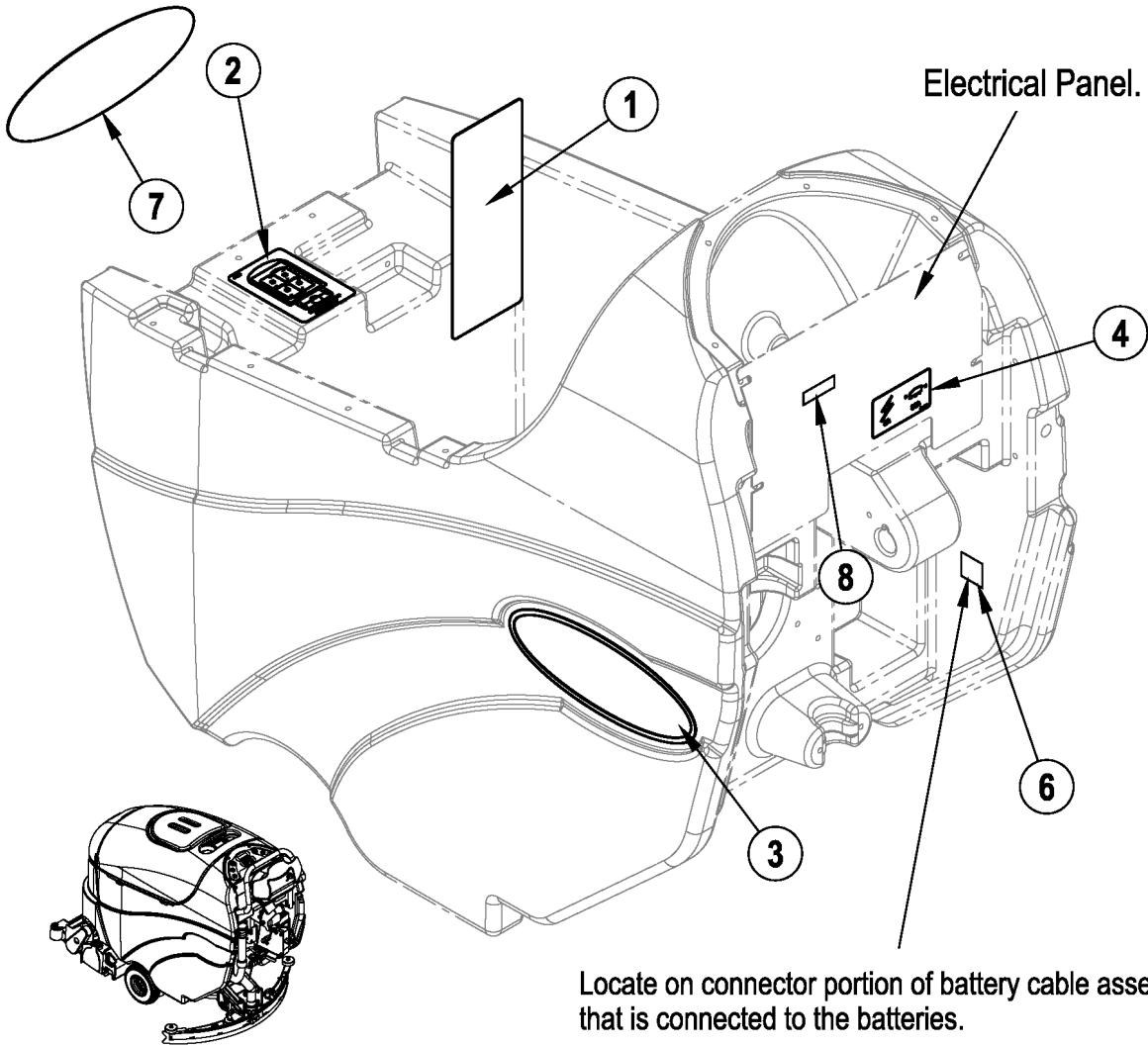

04-11

DECAL SYSTEM

10-9

Convertamatic™

9

Item	Ref. No.	Qty	Description
1	56014601	1	Decal, Caution
2	56016688	1	Decal, Battery Wiring
3	56016689	2	Decal, Convertamatic
	56315706	2	Decal, Convertamatic AXP
4	56016690	1	Decal, Circuit Breaker
6	56054192	1	Decal, Charger
7	56016349	1	Decal, Advance
8	56014450	1	Decal, Patent Number

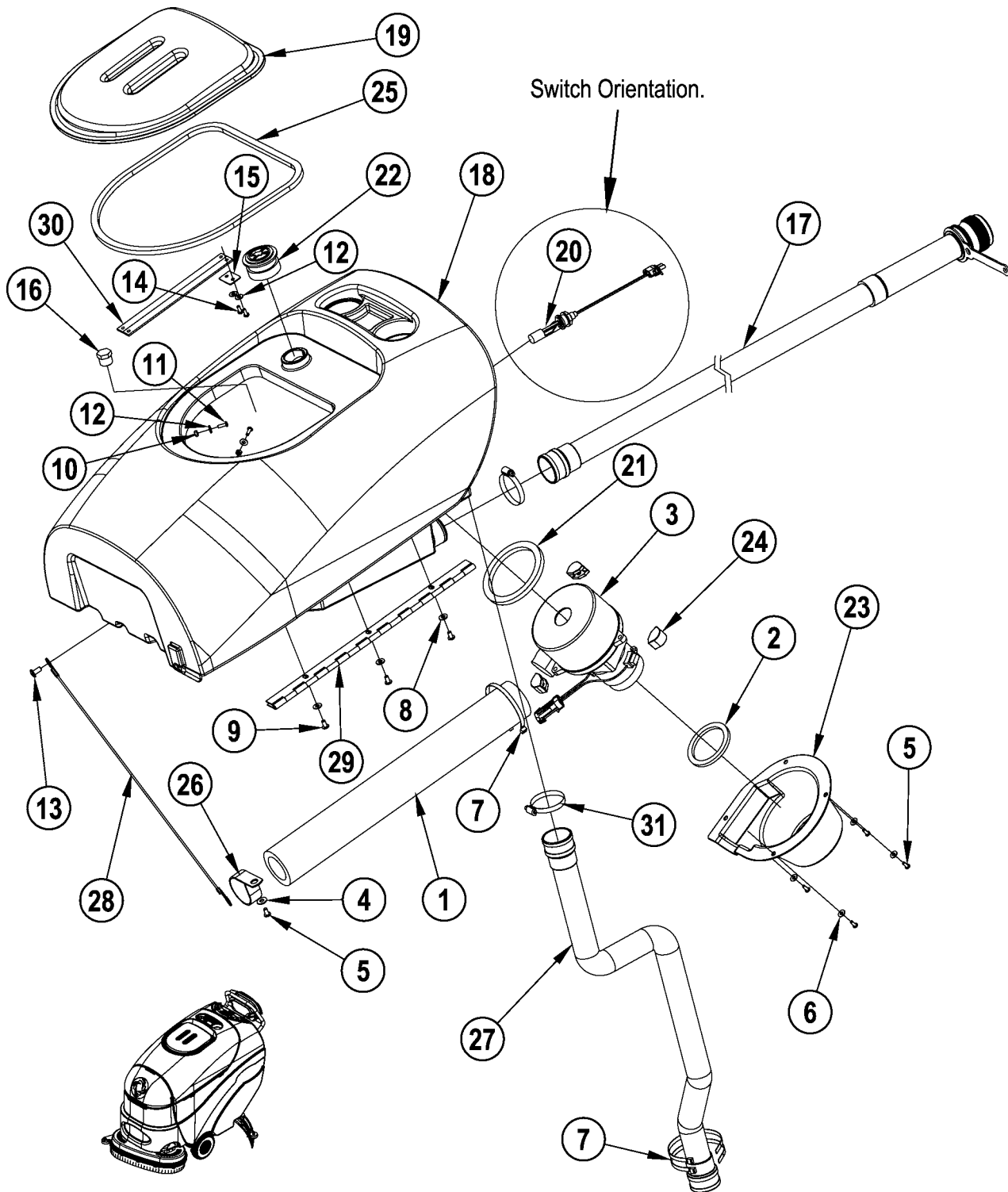

Item	Ref. No.	Qty	Description
1	56315375	1	Foam, Acoustical
2	56412154	1	Gasket, Vacuum Duct
3	56412218	1	Motor, Vac 24vdc (M4) TSBUS2009-1036
*	56397098	1	Carbon Brush set of 2 (for 56412218) NOTE 3
*	56380529	1	Carbon Brush set of 2 (for 56412218) NOTE 3
4	56001906	1	Wsh, Flt STD 1/4
5	56001993	5	Scr, Pan Phil 10-24x.50
6	56002053	4	Wsh, Flt STD #10
7	56477613	3	Tie, Cable
8	56002098	3	Wsh, Flt SAE 1/4
9	56002145	3	Scr, Pan Phil 1/4-20x.50
10	56002849	2	Nut, Hex Nyl Loc-Thin SS 10-24
11	56002896	2	Scr, Pan Phil SS 10-24x.62
12	56002919	4	Wsh, Flt STD SS #10
13	56003003	1	Scr, Pan Phil 5/16-18x.62
14	56009005	2	Scr, Pan Phil SS Type B 10-16 x .75
15	56315346	1	Plate
16	56305464	1	Plug, 3/4 Hex Pipe NOTE 1
17	56601400	1	Drain Hose NOTE 2
**	56601410	1	Drain Hose Extension (for use with 56601400)
*	56601411	1	Drain Hose Cap Kit
*	56601412	1	Drain Hose Kit NOTE 2
18	56315779	1	Tank, Recovery
19	56315176	1	Cover, Recovery Tank
20	56315096	1	Switch, Electromagnetic (S4)
21	56315098	1	Gasket
22	56315099	1	Screen, Fan Inlet
23	56315102	1	Shroud, Vac Motor
24	56315141	3	Mount, Vibration
25	56315220	1	Gasket, Recovery Lid
26	56315257	1	Clamp, P
27	56315268	1	Vac Hose Assy.
28	56315272	1	Cable Assy
29	56315293	1	Hinge
30	56315303	2	Retaining, Strap
31	56440213	2	Clamp, Hose SAE #32

* = Not Shown

** = Optional

NOTE 1: Not used after March 2008.

NOTE 2: Drain Hose 56397142 has been replaced by Drain Hose 56601400 in production. When replacing 56397142 you need to order Drain Hose Kit 56601412.

NOTE 3: If your vacuum motor has a serial tag from Lamb Electric (Ametek) order Carbon Brush Set 56397098.
If your vacuum motor has a serial tag from Nilfisk-Advance order Carbon Brush Set 56380529.

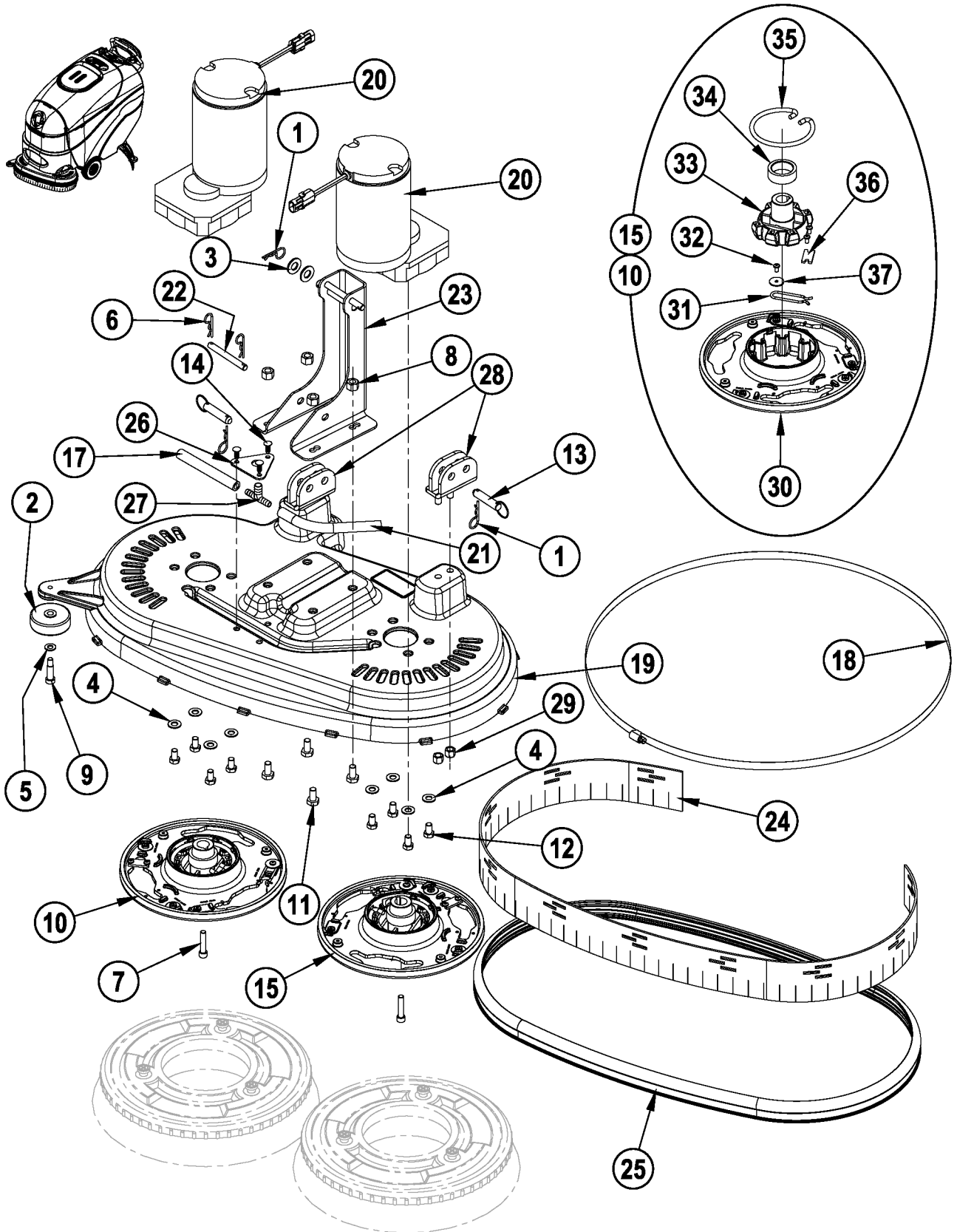

Item	Ref. No.	Qty	Description	Item	Ref. No.	Qty	Description
1	56002959	3	Pin, Cotter Hair NOTE 3	23	56315718	1	Weld't, Deck Actuator (24", 26") NOTE 2
2	56324350	1	Wheel				NOTE 3
3	56001879	2	Wsh, Flt SAE 1/2 NOTE 3	56315719	1	Weld't, Deck Actuator (28") NOTE 2	
4	56002910	8	Wsh, Flt SAE SS 3/8				NOTE 3
5	56002938	1	Wsh, Flt SAE SS 5/16	24	56315275	1	Skirt, Rubber (26")
6	56003120	2	Pin, Cotter Hair .0915 X .375		56315274	1	Skirt, Rubber (24", 28")
7	56002201	2	Scr, Soc Hd 5/16-18 x 1.50 NOTE 5	25	56315754	1	Bumper, Extruded (28") NOTE 4
8	56003438	4	Nut, Hex Nyl Loc SS M10x1.5		56315753	1	Bumper, Extruded (26") NOTE 4
9	56003472	1	Scr, Soc Shd .38 X 1.00 X 5/16-18		56315752	1	Bumper, Extruded (24") NOTE 4
10	56109651	1	Brush Plate Assy (30-37) NOTE 5 / TSBUS2009-1039	26	56315339	1	Bracket
11	56003533	4	Scr, Hex Hd SS M10-1.5x20mm	27	56397300	1	Tee, Barb NOTE 1
12	56003674	8	Scr Hex Loc SS 3/8-24 X .62	28	56315373	2	Weld't, Deck Mount Brkt NOTE 2
13	56003679	2	Pin, Ring .50 X 1.63	29	56002769	4	Nut, Hex Nyl Loc 3/8-16 NOTE 2
14	56003693	3	Rivet, Nylon Tree Push-In (.218)	30	56601118	1	Brush Plate NOTE 5
15	56109652	1	Brush Plate Assy (30-37) NOTE 5 / TSBUS2009-1039	31	56109653	1	Spring Retainer NOTE 5
17	56257534	1	Hose, PVC .375	32	56009247	3	Scr, Pan Phil Plastite 10-14 X .38 NOTE 5
18	56315759	1	Band Clamp (28")	33	56601520	1	Gimbal, Motor NOTE 5
	56315742	1	Band Clamp (24", 26")	34	61658a	1	Collar, Brush Driver NOTE 5
19	56315588	1	Scrub Deck, Disc, Cast, 28 NOTE 2	35	56601056	1	Spring, Brush Holder NOTE 5
	56315587	1	Scrub Deck, Disc, Cast, 26 NOTE 2	36	56366455	1	Plate, Stop NOTE 5
	56315586	1	Scrub Deck, Disc, Cast, 24 NOTE 2	37	56009002	1	Wsh, Flt .266 X .906 X .060 NOTE 5
20	56315056	2	Asm, Motor And Gear Unit, .42hp (M2 / M3)				
*	56315376	4	Carbon Brush				* = Not Shown
*	56397138	4	Brush Spring				
21	56315060	1	Hose, PVC .375				
22	56315161	1	Pin				

NOTE 1: The previous solution hose design which consisted of a Reducer (56418669), Hose Clamps (56219932) and a smaller 3/8" diameter Hose (56456830) to the scrub deck has been replaced in production with a single 1/2" diameter hose (56264318). If ordering Tee 56397300 for a machine with this previous design solution hose you will also need to order Solution Hose 56264318. See **NOTE 1** on **SOLUTION SYSTEM / ELECTRICAL-1**.

NOTE 2: The Deck Casting (item #19) has been redesigned. The old style castings (56315053 - 28", 56315054 - 26" & 56315055 - 24") are no longer available. If you have a machine built prior to this change (**old style deck assembly DOES NOT include item 38**) and need to replace one of these deck castings you need to order one of the kits listed below. These kits include items (8, 11, 14, 19, 23, 38, 39).

Old Deck	Order Kit
56315053 (28")	56315727
56315054 (26")	56315726
56315055 (24")	56315725

NOTE 3: Actuator Weldment Item #23 has been redesigned (in April of 2007) to accommodate a new upper deck linkage arm (see **Solution System / Electrical-1**). The redesigned weldment is backwards compatible to the previous design. The new design does not use item #3 and the quantity of item #1 is reduced to 2.

NOTE 4: Extruded Bumpers PNs 56315318, 56315277 & 56315276 are obsolete. If you need to replace one of these bumpers please order one of the kits listed below.

Old Bumper	Order Kit
56315318 (28")	56315764
56315277 (26")	56315763
56315276 (24")	56315762

NOTE 5: Drive Lugs 56396080 and 56396081 are both obsolete and replaced by 56109625 and 56109626 respectively. The old individual parts are still available for replacement and listed below.

Item	Ref. No.	Qty	Description
38	56396080	1	Lug, Counterclockwise (40-51) NOTE 5
39	56396081	1	Lug, Clockwise (40-51) NOTE 5
40	56003335	2	Scr Hex Loc SS 5/16-18 X .88
41	56003477	6	Scr, Hex Loc SS M8-1x25mm
42	56009107	2	Wsh, Flt SS .378 X 1.000 X .120
43	56314108	2	Hub, Drive
44	56002938	6	Wsh, Flt SAE SS 5/16
45	56003405	3	Nut, Hex Nyl Loc SS M8-1.25
46	56003639	3	Scr, Hex Hd SS M8-1.25 x 25mm
47	56009030	1	Scr, Pan Phil Thd Form 10-24 x .38
48	56009096	1	Wsh, Flt .193 x .875 x .060
49	56407053	2	Thermoid Disk
50	56314030	1	Brush Holder
51	56397081	1	Spring Retainer

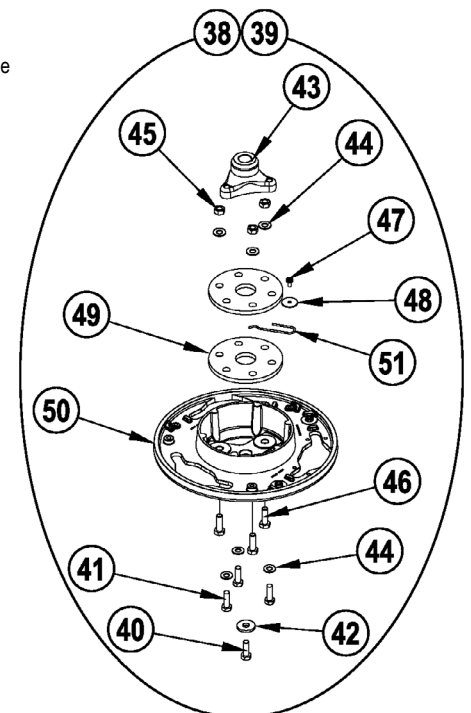

FORM NO. 56042451

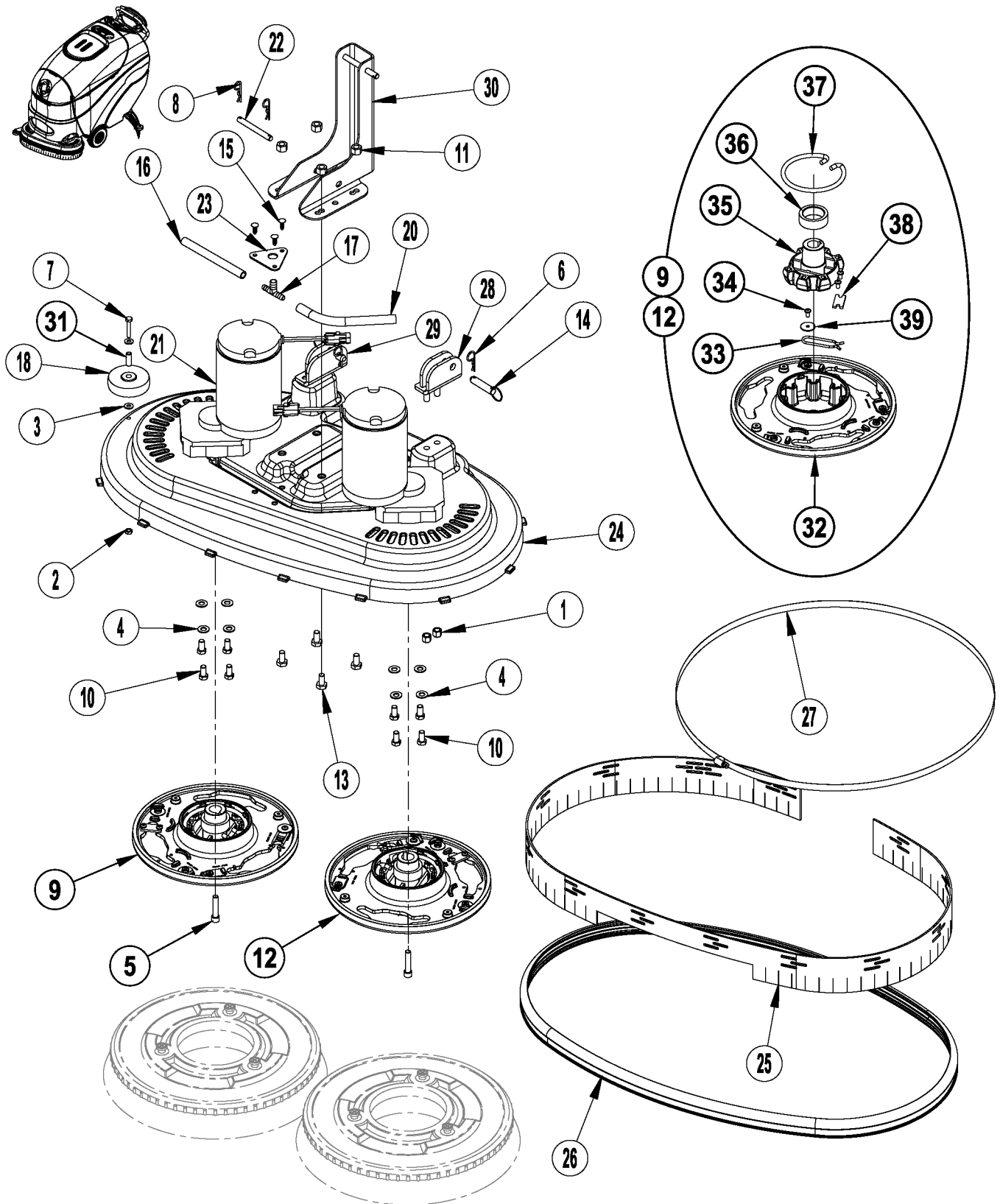

04-11

SCRUB SYSTEM - DISK (32")

09-12

Convertamatic™**15**

Item	Ref. No.	Qty	Description
1	56002769	4	Nut, Hex Nyl Loc 3/8-16
2	56002850	1	Nut, Hex Nyl Loc-Thin SS 1/4-20
3	56002859	2	Wsh, Flt SAE SS 1/4
4	56002910	8	Wsh, Flt SAE SS 3/8
5	56002201	2	Scr, Soc Hd 5/16-18 x 1.50 NOTE 1
6	56002959	2	Pin, Cotter Hair
7	56002880	1	Scr, Hex Loc SS 1/4-20 X 1.75
8	56003120	2	Pin, Cotter Hair .0915 X .375
9	56109651	1	Brush Plate Assy (32-39) NOTE 1 / TSBUS2009-1039
10	56003338	8	Scr, Hex Loc SS 3/8-16 X .75
11	56003438	4	Nut, Hex Nyl Loc SS M10-1.5
12	56109652	1	Brush Plate Assy (32-39) NOTE 1 / TSBUS2009-1039
13	56003533	4	Scr, Hex SS M10-1.5 X 20mm
14	56003679	2	Pin, Ring .50 X 1.63
15	56003693	3	Rivet, Nylon Tree Push-In (.218)
16	56396195	1	Hose, PVC .38id X 6.00
17	56397300	1	Tee, Barb
18	56049261	1	Wheel
20	56397301	1	Hose, PVC .375
21	56315056	2	Asm, Motor And Gear Unit, .42HP (M2 / M3)
*	56315376	4	Carbon Brush
*	56397138	4	Brush Spring
22	56315161	1	Pin
23	56315339	1	Bracket
24	56315859	1	Scrub Deck, Disc, Cast, 32"
25	56315626	1	Skirt, Rubber 32"
26	56315755	1	Extruded Bumper, 32" Deck
27	56315761	1	Band Clamp, Adjustable
28	56315821	1	Deck Mount Brkt Weldt, Lhs
29	56315823	1	Deck Mount Brkt Weldt, Rhs
30	56315826	1	Bracket Weld't
31	56315580	1	Bushing, Stainless
32	56601118	1	Brush Plate NOTE 1
33	56109653	1	Spring Retainer NOTE 1
34	56009247	3	Scr, Pan Phil Plastite 10-14 X .38 NOTE 1
35	56601520	1	Gimbal, Motor NOTE 1
36	61658a	1	Collar, Brush Driver NOTE 1
37	56601056	1	Spring, Brush Holder NOTE 1
38	56366455	1	Plate, Stop NOTE 1
39	56009002	1	Wsh, Flt .266 X .906 X .060 NOTE 1

* = Not Shown

NOTE 1: See NOTE 5 on **SCRUB SYSTEM - DISK (24", 26", 28")**

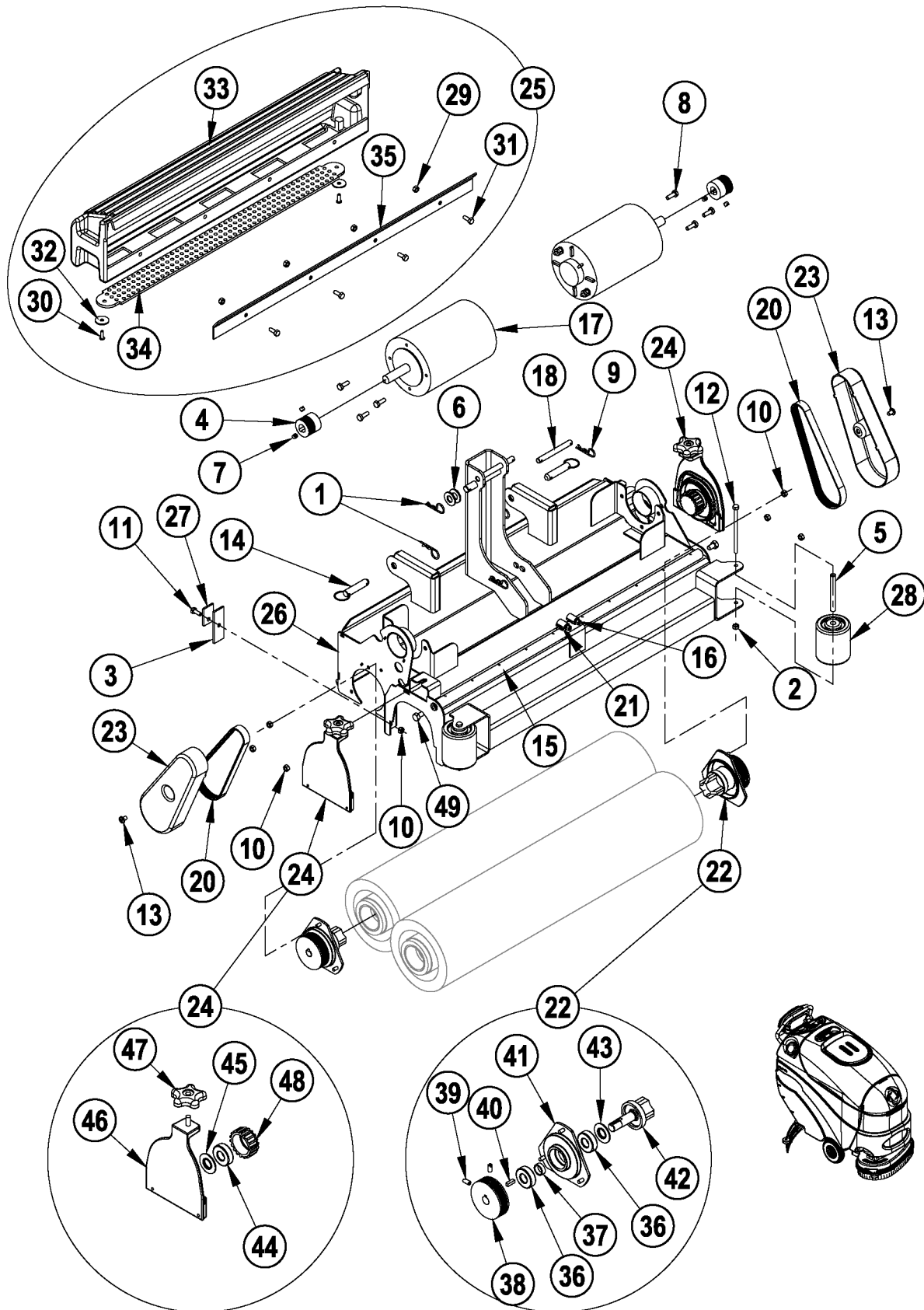

Item	Ref. No.	Qty	Description	Item	Ref. No.	Qty	Description
1	56002959	3	Pin, Cotter Hair NOTE 2	27	56410214	2	Strap
2	56003403	2	Nut, Hex Nyl Loc M6-1.00	28	56412459	2	Wheel
3	56407391	2	Blade	29	56003426	4	Nut, Hex Nyl Loc SS M6-1.00
4	56407433	2	Sheave, Poly-V	30	56002896	2	Scr, Pan Phil SS 10-24 x .62
5	56412176	2	Bushing	31	56003431	4	Scr, Hex Hd SS M6-1.00 x 16mm
6	56001879	6	Wsh, Flt SAE 1/2 NOTE 2	32	56009060	2	Wsh, Flt SS .260 x 1.00 x .074
7	56002086	4	Scr, Soc Set Loc 5/16-18x.25	33	56315460	1	Hopper (28")
8	56002948	6	Scr, Hex Hd Loc 1/4-20x.75		56315454	1	Hopper (26")
9	56003120	2	Pin, Cotter Hair .0915 X .375		56315401	1	Hopper (24")
10	56003426	8	Nut, Hex Nyl Loc SS M6x1.0	34	56315464	1	Hopper Screen (28")
11	56003431	2	Scr, Hex Hd SS M6-1.0x16mm		56315462	1	Hopper Screen (26")
12	56003492	2	Scr, Hex M6-1.0x95mm		56315319	1	Hopper Screen (24")
13	56003603	2	Scr, Pan Phil Thd Form 1/4-20x.38	35	56315467	1	Hopper Bracket (28")
14	56003679	2	Pin, Ring .50 X 1.63		56315466	1	Hopper Bracket (26")
15	56315355	2	Manifold, PVC (28")		56315465	1	Hopper Bracket (24")
	56315354	2	Manifold, PVC (26")	36	56106070	2	Bearing, Ball
	56315353	2	Manifold, PVC (24")	37	56407389	1	Spacer
16	56112771	2	Clamp, Hose SAE #10	38	56407442	1	Sheave, Poly-V
17	56315061	2	Motor, 24 Vdc, .5 Hp, 1800 RPM (M2 / M3) TSBUS2010-1058	39	56002119	2	Scr, Soc Set Loc 1/4-20 x .50
*	56412287	1	Brush / Spring Kit NOTE 3	40	56003237	1	Key, Sq. .19 x .62
*	56380003	1	Brush / Spring Kit NOTE 3	41	56315405	1	Bearing Plate
18	56315161	1	Pin	42	56109527	1	Spindle
19	56315320	2	Harness, Brush	43	56407558	1	Washer, Bearing
20	56315321	2	Belt, Auto Tension	44	56106070	1	Bearing, Ball
21	56262549	1	Tee, Barb NOTE 1	45	56407558	1	Washer, Bearing
22	56315408	2	Drive End Assy (#36-43)	46	56315447	1	Idler Bearing Plate
23	56315445	2	Cover, Belt	47	56396254	1	Knob
24	56315448	2	Idler End Assy (#44-48)	48	56407551	1	Hub
25	56315459	1	Hopper Assembly (28" / #29-35)				
	56315453	1	Hopper Assembly (26" / #29-35)				
	56315403	1	Hopper Assembly (24" / #29-35)				
26	56315470	1	Housing, Weld't (28")				
	56315469	1	Housing, Weld't (26")				
	56315468	1	Housing, Weld't (24")				

* = Not Shown

NOTE 1: The previous solution hose design which consisted of a Reducer (56418669), Hose Clamps (56219932) and a smaller 3/8" diameter Hose (56456830) to the scrub deck has been replaced in production with a single 1/2" diameter hose (56264318). If ordering Tee 56262549 for a machine with this previous design solution hose you will also need to order Solution Hose 56264318. See **NOTE 1** on **SOLUTION SYSTEM / ELECTRICAL-1**.

NOTE 2: Housing Weldment Item #26 has been redesigned (in April of 2007) to accommodate a new upper deck linkage arm (see **Solution System / Electrical-1**). The redesigned weldment is backwards compatible to the previous design. On machines with the new design the quantity of item #1 is reduced to 2 and the quantity of item #6 is reduced to 4.

NOTE 3: If your cylindrical scrub motor has a serial tag from Scott Motors Co. (4BB1344) order Carbon Brush Set 56412287.
If your cylindrical scrub motor has a serial tag from Nilfisk-Advance (ZD22000) order Carbon Brush Set 56380003.

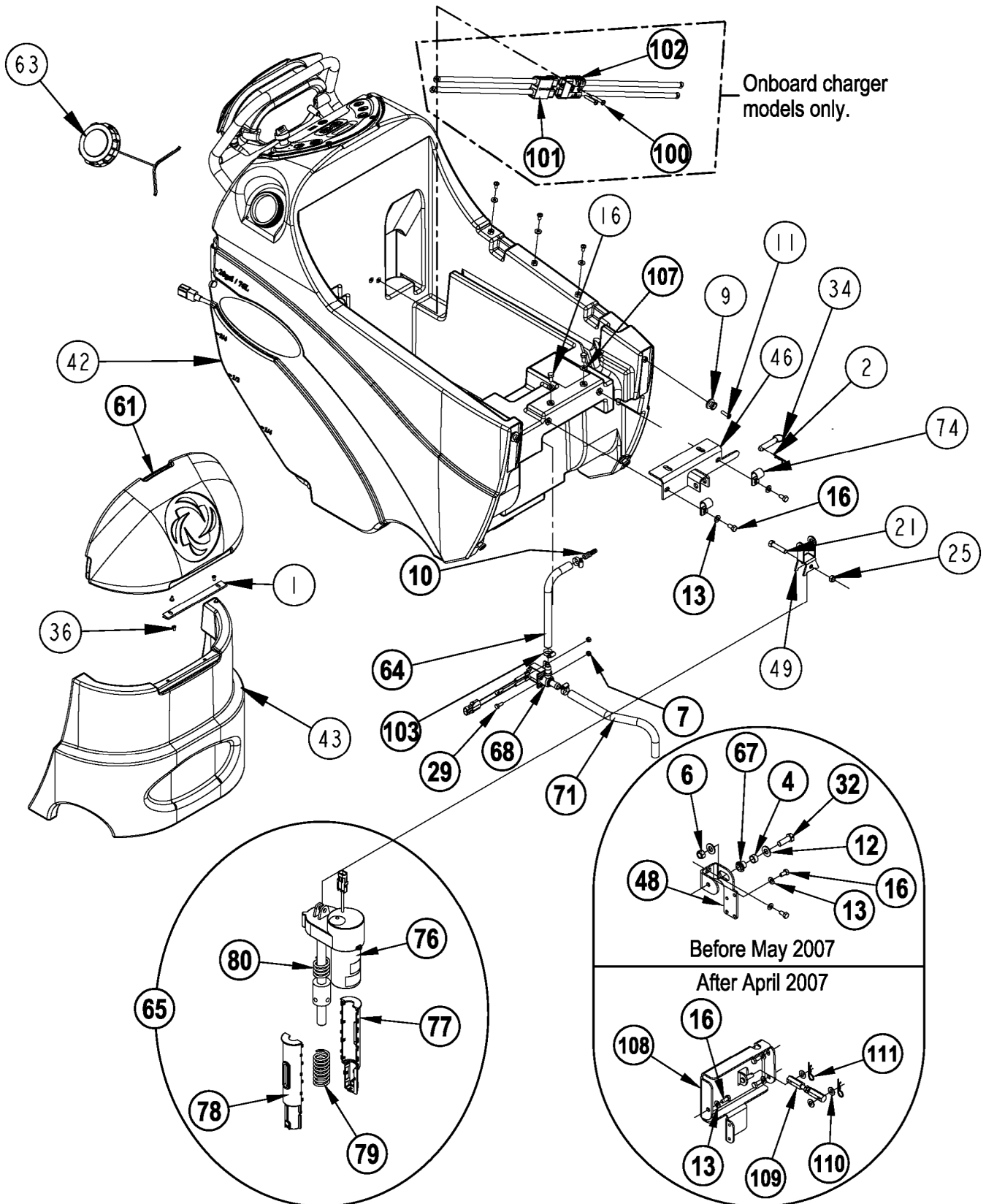

Item	Ref. No.	Qty	Description
1	56315285	1	Hinge
2	56002959	1	Pin, Cotter Hair
4	56370878	1	Bearing, Sleeve only used before May 2007
6	56003312	1	Nut, Hex Nyl Loc M12-1.75 only used before May 2007
7	56003403	2	Nut, Hex Nyl Loc M6-1.00
9	56365777	4	Lug, Brush Driver
10	56418669	1	Reducer, Barb
11	56001832	4	Scr, Flt Phil 1/4-20x1.00
12	56001879	2	Wsh, Flt SAE 1/2
13	56001939	4	Wsh, Flt SAE 5/16 QTY of 5 after April 2007
16	56002667	6	Scr, Hex Hd 5/16-18x.75 QTY of 7 after April 2007
21	56002684	1	Scr, Hex Hd 3/8-16x1.75
25	56002841	1	Nut, Hex Nyl Loc-Thin 3/8-16
29	56003174	2	Scr Hex Thd To Hd M6-1.0x16mm
32	56003637	1	Scr, Hex M12-1.75x40mm only used before May 2007
34	56003679	1	Pin, Ring .50 X 1.63
36	56009139	4	Scr, Pan Phil Loc 10-24x.38
42	56315089	1	Tank, Solution
**	56109561	1	Solution Tank Kit NOTE 3 / TSBUS2008-1017
43	56315104	1	Nose Cone, 24-26 Commercial
46	56315130	1	Weldment, Actuator Mount
48	56315186	1	Bracket, Linkage Pivot only used before May 2007
49	56315191	1	Yoke, Actuator
61	56315284	1	Cover, Chemical Bottle
63	56601599	1	Cap, Raw W/Tether NOTE 2
64	56387302	1	Spiral, Hose X .500
65	56109595	1	Lift Actuator Assembly (76-80) NOTE 4 / TSBUS2009-1040
67	56315380	1	Bushing only used before May 2007
68	56397203	1	Solenoid Valve Assy. (L1)
71	56264318	1	Hose, Spiral .500 NOTE 1
74	56469380	2	Clamp, P
76	56109597	1	Actuator (M5)
*	56109596	1	Plastic Nut
*	56109636	1	Spring Housing Kit
77	56109547	1	Spring Housing Bottom
78	56109546	1	Spring Housing Top
79	56420018	1	Compression Spring
80	56412071	1	Compression Spring
100	56002786	2	Scr, Pan Phil 1/4-20 x 1.50 (onboard charger only)
101	56397188	1	Connector Assy (connected to batteries / onboard charger only)
102	56397187	1	Connector Assy (connected to machine / onboard charger only)
103	56219932	3	Clamp, Hose SAE #6
107	56009122	2	Wsh, Flt .344 x .938 x .125
108	56315839	1	Bracket Weld't only used after April 2007
109	56315836	1	Turnbuckle Assy only used after April 2007
110	56002063	3	Wsh, Flt SAE 3/8 only used after April 2007
111	56003120	2	Pin, Cotter Hair .0915 x .375 only used after April 2007

* = Not Shown

NOTE 1: The previous solution hose design which consisted of a Reducer (56418669), Hose Clamps (56219932) and a smaller 3/8" diameter Hose (56456830) to the scrub deck has been replaced in production with a single 1/2" diameter hose (56264318). If ordering this new hose (56264318) for a machine with the previous design you will also need to order a new Tee (56397300 for disc / 56262549 for cylindrical) for the scrub deck. See **NOTE 1** on **SCRUB SYSTEM – DISK (24", 26", 28")** and **SCRUB SYSTEM – CYLINDRICAL**.

NOTE 2: The previous Solution Tank Caps 56315517 & 56109519 are obsolete. The new Cap 56601599 can be used in place of the originals.

NOTE 3: This solution tank kit is to be ordered if you need to replace a solution tank on a machine before serial number 2059967.

NOTE 4: Actuator 56109595 replaces actuator 56396049 as of September 2009.

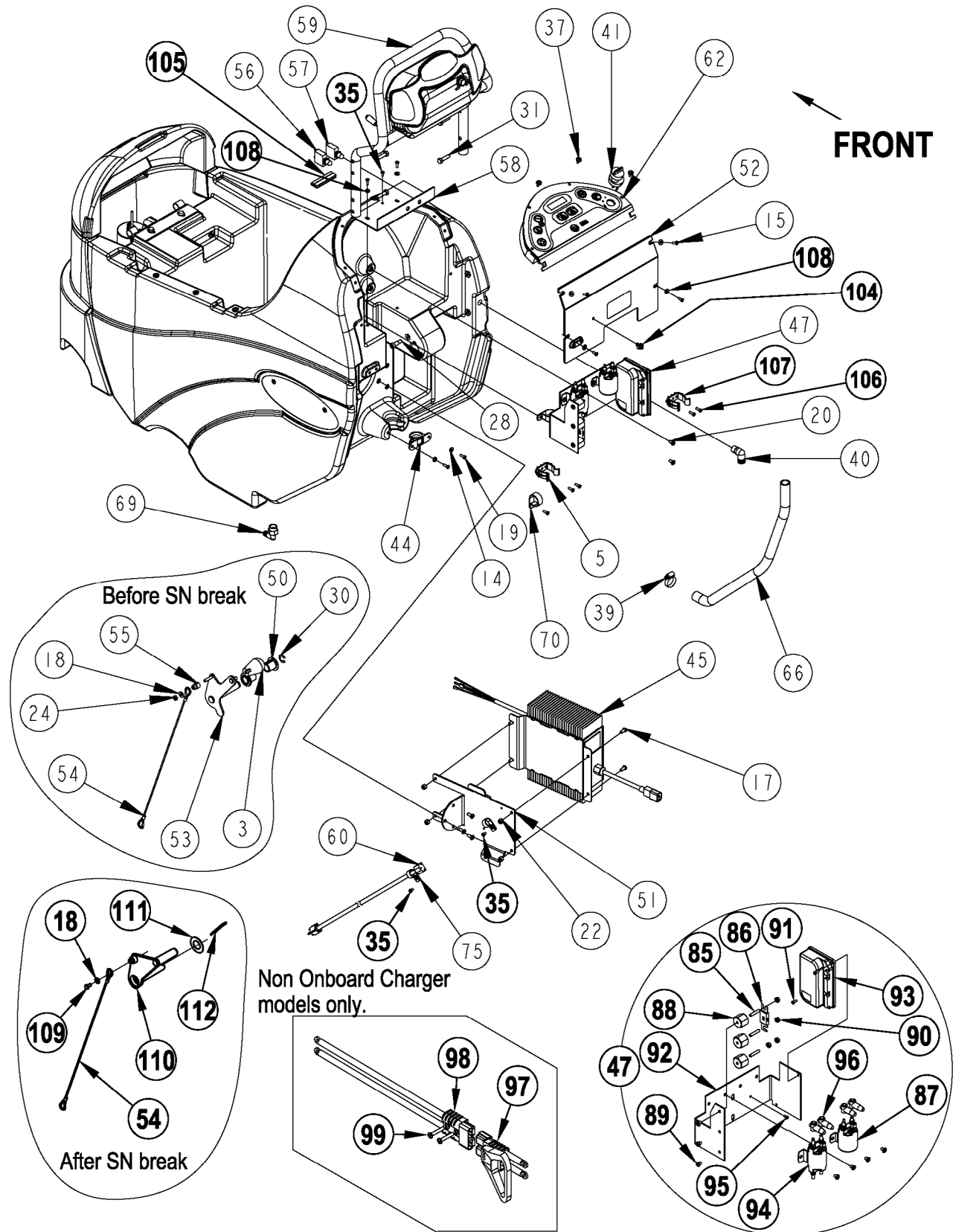

Item	Ref. No.	Qty	Description	Item	Ref. No.	Qty	Description
3	56364527	1	Knob NOTE 4	58	56109553	1	Plate, Circuit Breaker
5	56407361	1	Clamp, Plastic	59	56315266	1	Assembly, Paddle TSBUS2005-898
14	56001954	2	Wsh, Fit SAE #10	60	56315270	1	Charger Cord, Us (Onboard Charger Only)
15	56001993	4	Scr, Pan Phil 10-24x.50	62	56315297	1	Control Panel Assy (A1) NOTE 1
17	56002066	7	Scr, Pan Phil 1/4-20x.62 (Onboard Charger Only)		56315777	1	Control Panel Assy (A1) NOTE 2
18	56002098	4	Wsh, Fit SAE 1/4	66	56396143	1	Hose, PVC
19	56002124	12	Scr, Pan Phil 10-24x.62	69	56409152	1	Barb, 90 Elbow 1/2 X 1/2NPT
20	56002145	5	Scr, Pan Phil 1/4-20x.50	70	56410166	2	Clamp, P
22	56002708	4	Nut, Hex Nyl Loc 1/4-20 (Onboard Charger Only)	75	56486112	2	Clamp, P (Onboard Charger Only)
24	56002840	1	Nut, Hex Nyl Loc-Thin 1/4-20 NOTE 4	85	56009203	3	Stud, 1/4-20
28	56002962	1	Scr, Soc Shd .38 X .62 X 5/16-18 NOTE 4	86	56412089	1	Fuse, 150 Amp (F1)
30	56003266	1	Ring, Ret Ext Type E 0.75 Dia NOTE 4	87	56412179	1	Contactor, 24 Vdc (K2 / Vac Motor)
31	56002094	4	Scr, Hex Hd 5/16-18x1.50	88	56469858	3	Standoff, Insulated
35	56009030	3	Scr, Pan Phil Thd Form 10-24x.38 (Qty of 1 on Non-Onboard Charger models)	89	56002462	7	Scr, Pan Phil 1/4-20x.38
37	56009206	4	Scr, Truss Phil-Blk 10-24x.50	90	56002561	4	Nut, Hex W/ Shprf 1/4-20
39	56244969	1	Clamp, Hose SAE #12	91	56003698	2	Scr, Pan Phil Thd Form 8-32 x .75
40	56264442	1	Barb, 90 Elbow 3/4 X 3/8npt	92	56315182	1	Panel, Electrical
41	56303553	1	Key Switch Assembly	93	56315294	1	Speed Control (A2)
*	56303526	A/R	Set of 2 Replacement Keys	94	56397088	1	Contactor, 24v Spdt (K1 / Brush Motor)
44	56315121	1	Guide, Cable	95	56009030	1	Scr, Pan Phil Thd Form 10-24x.38
45	56315124	1	Charger, On-Board 24V NOTE 3 TSBUS2006-931, TSBUS2008-1008	96	56409538	4	Insulator, Terminal
*	56315747	1	Thermistor Repair Kit for 56315124	97	56315345	1	Connector Assy (connected to batteries) (non onboard charger only)
47	56315162	1	Assy, Electrical Box (85-96) TSBUS2005-897 TSBUS2006-926	98	56397187	1	Connector Assy (connected to machine) (non onboard charger only)
50	56315193	2	Bushing, Flange NOTE 4	99	56002825	2	Scr, Pan Phil 1/4-20 x 1.25 (non onboard charger only)
51	56315206	1	Bracket, Charger (Onboard Charger Only)	104	56315382	1	Clip, Conduit
52	56109502	1	Panel, Electrical Assy	106	56001993	2	Scr, Pan Phil 10-24 x .50
53	56315236	1	Weldment, Squeegee Lift NOTE 4	107	56212236	1	Clamp, Plastic
54	56315243	1	Cable Assy	108	56002053	6	Wsh, Fit STD #10
55	56315245	1	Bushing, Squeegee Cable NOTE 4	109	56001854	1	Scr, Hex 1/4-20 x .50 NOTE 5
56	56315255	1	Circuit Breaker, 5 Amp	110	56315730	1	Lever, Squeegee Lift NOTE 5
57	56315256	1	Circuit Breaker, 30 Amp	111	56009117	1	Wsh, Fit 1.031 x 1.859 x 0.48 NOTE 5
				112	56003223	1	Pin, Cot Hair.148 x Dia .62/1.00 NOTE 5

* = Not Shown

NOTE 1: Order this control panel assy if you have the "Old Pump" voltage reading across the solution pump (**M8**) leads.

NOTE 2: Order this control panel assy if you have the "New Pump" voltage reading across the solution pump (**M8**) leads.

	Voltage
Regular Scrub	
Old Pump	7
New Pump	9.56
Heavy Scrub	
Old Pump	11.3
New Pump	13.7
Extreme Scrub	
Old Pump	17
New Pump	19.24

NOTE 3: Starting with Charger serial # CP240548022382 the charger software can be programmed with a computer and the QuiQ Programmer kit 56315732.

NOTE 4: Used before SN 2059968. Items 50 and 53 are obsolete, to replace order each of the following part numbers 56001854, 56315730, 56009117, 56003223 (qty 1).

NOTE 5: Used after SN 2059967.

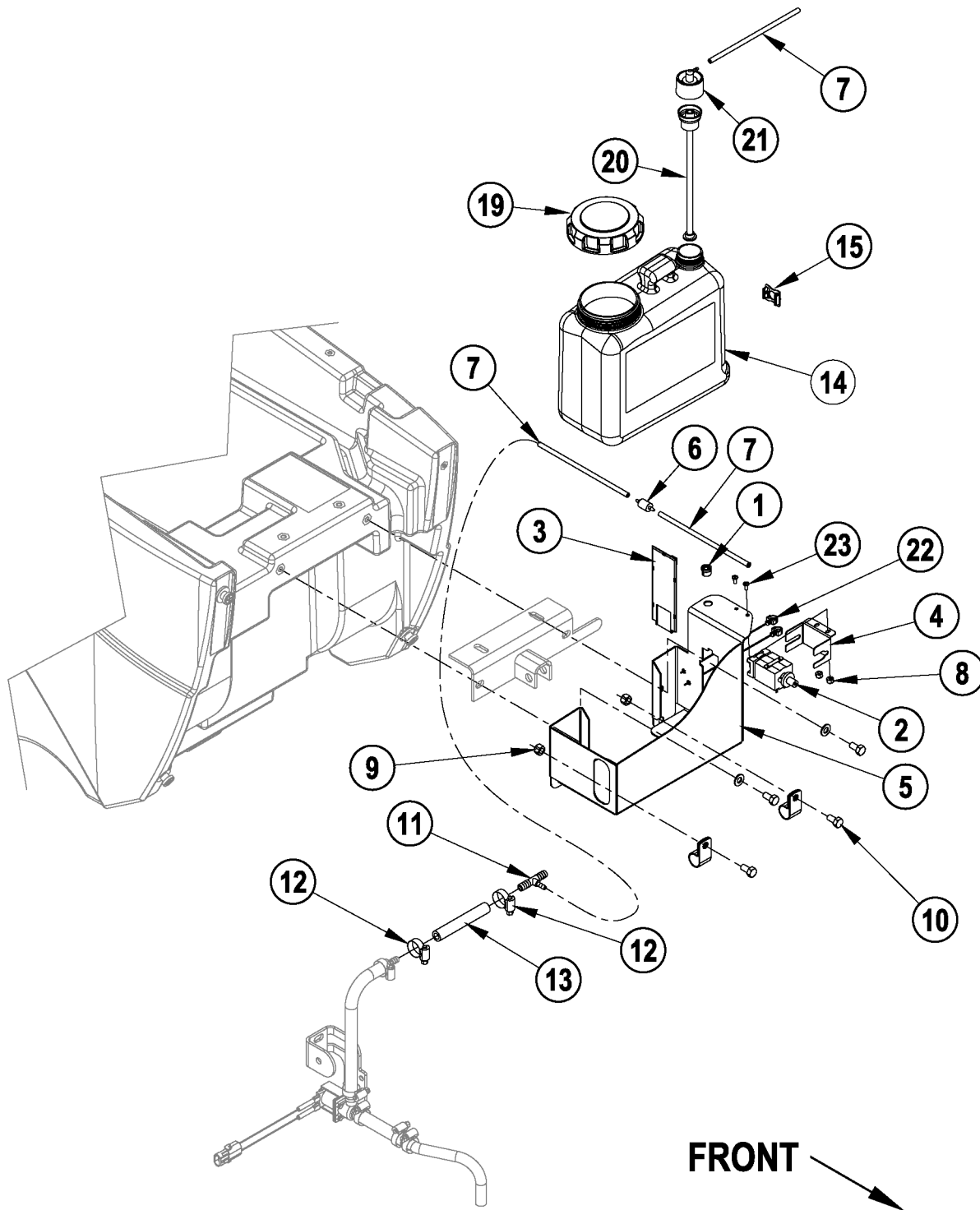

04-11

CHEMICAL ASSEMBLY (AXP MODELS ONLY)

08-4

Convertamatic™**23**

Item	Ref. No.	Qty	Description
	56315501	1	Chemical Tank Assy (1-8 & 22-23)
1	56003699	1	Bushing, 1/4 ID Snub
2	56315241	1	Pump, Chemical
3	56315340	1	Circuit Board Assy
4	56315476	1	Bracket, Chemical Pump
5	56315515	1	Bracket, Tank Mounting
6	56315522	1	Check Valve, 1/8 Barb, 125PSI
7	56315524	3	Hose, Chemical Resistant, 7"
8	56002877	2	Nut, Hex Nyl Loc SS 8-32
9	56002701	2	Nut, Hex Nyl Loc 5/16-18
10	56002035	2	Scr, Hex Hd 5/16-18 x .62
11	56315265	1	Tee, Barb
12	56219932	2	Clamp, Hose SAE #6
13	56412187	1	Hose, .38 Spiral
14	56315502	1	Chemical Bottle As
**	56315503	A/R	Chemical Bottle Assy (14, 19, 20, 21)
15	56315511	1	Indicator Assy
19	56315517	1	Cap
20	56315527	1	Insert, Dry Break
21	56315523	1	Cap, Dry Break, 1/8 Barb, 90°
22	56315382	2	Clip, Conduit
23	56003018	2	Scr, Pan Phil SS 8-32 x .38

** = Optional, Not Included

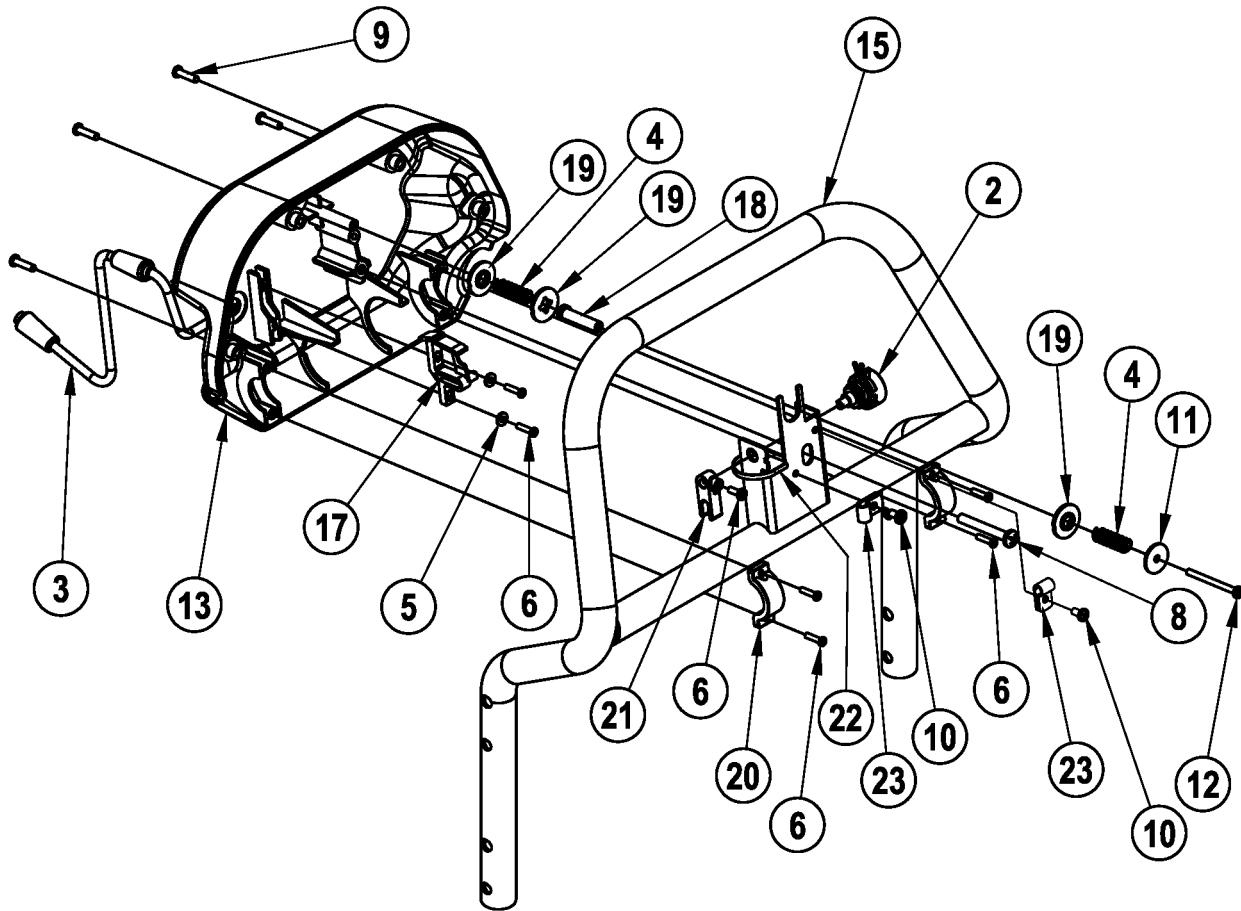

FRONT

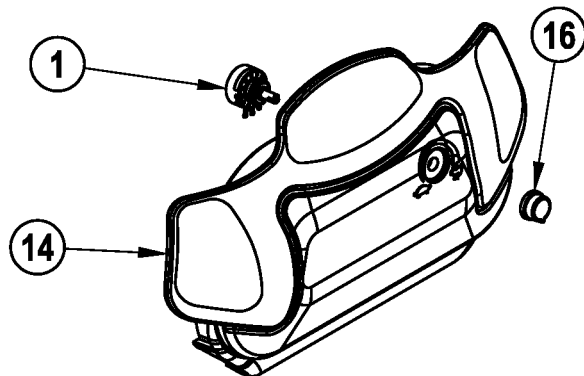

04-11	PADDLE ASSEMBLY		
09-12	Convertamatic™		25

Item	Ref. No.	Qty	Description
	56315266	1	Assembly, Paddle TSBUS2005-898 / TSBUS2006-925
1	56396197	1	Potentiometer, 100k (R2)
2	56397029	1	Potentiometer, 5k (R1)
3	56315231	1	Harness, Handle
4	56325654	2	Spring, Compression
5	56002006	2	Wsh, Flt SAE #6
6	56003197	7	Scr, Pan Phil Plastite 6-18x.62
8	56003527	1	Scr, Pan Phil Plastite 1/4-10x2.00
9	56003545	4	Scr, Pan Phil Plastite 8-10x.75
10	56009030	2	Scr, Pan Phil Thd Form 10-24x.38
11	56009096	1	Wsh, Flt .193 X .875 X .060
12	56009287	1	Scr, Pan Phil Type B 8x2.00
13	56109716	1	Paddle, Back Cover
14	56315230	1	Paddle, Front Cover
15	56315251	1	Weldment, Handle Bar
16	56315280	1	Knob
17	56397015	1	Cam Controller
18	56397109	1	Sleeve
19	56397170	3	Washer, Plastic
20	56397171	2	Clamp
21	56109648	1	Potentiometer Fork
22	56478246	1	Tie, Cable
23	56481890	2	Clamp, P

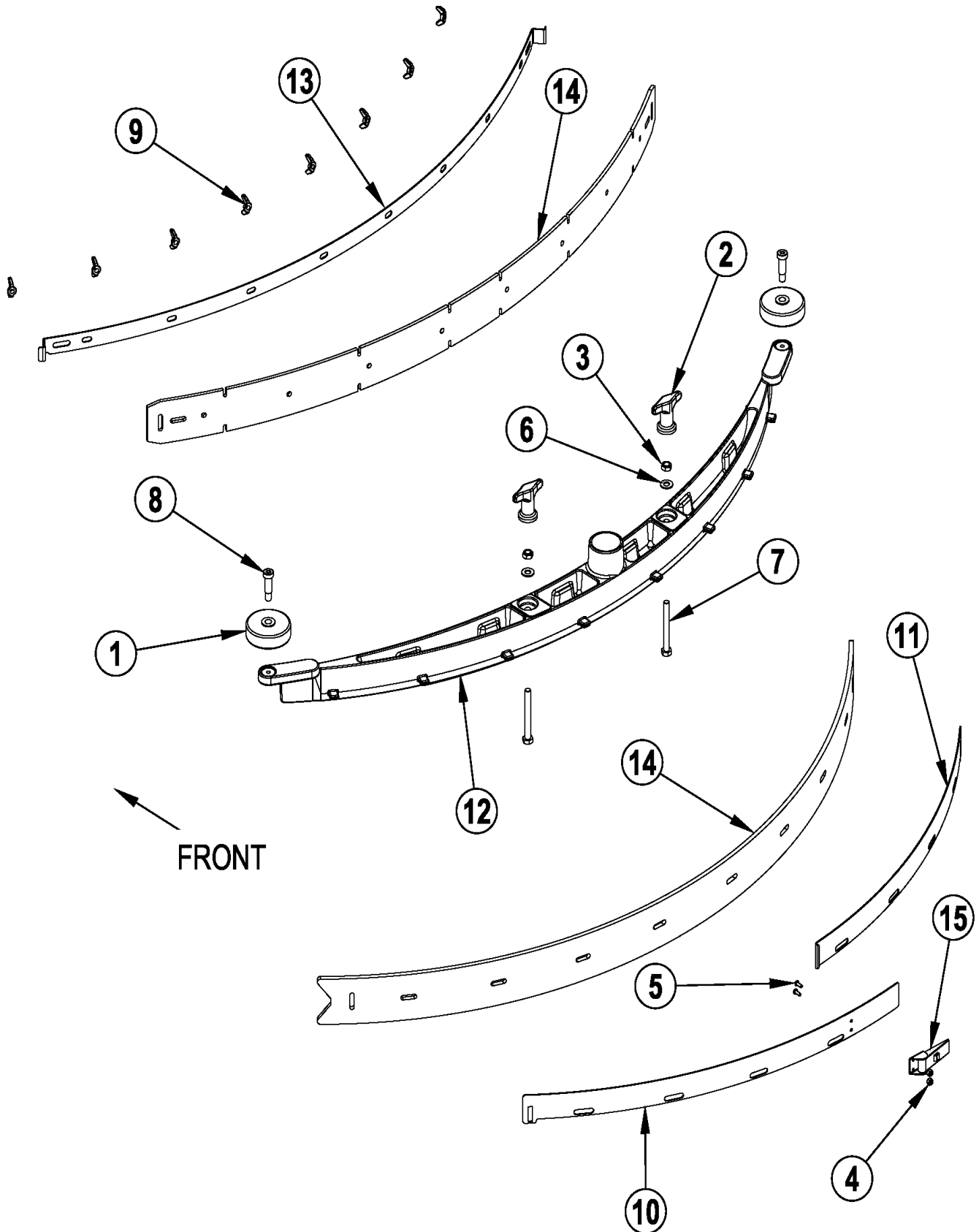

Item	Ref. No.	Qty	Description
	56315291	1	Squeegee Assembly "B" (24") NOTE 2
	56315290	1	Squeegee Assembly "C" (26" & 28") NOTE 2
	56315632	1	Squeegee Assembly "D" (32") NOTE 2
1	56324350	2	Wheel
2	56370711	2	Nut, Thumb
3	56002851	2	Nut, Hex Nyl Loc-Thin SS 5/16-18
4	56002907	2	Nut, Hex Nyl Loc SS 6-32
5	56002909	2	Scr, Pan Phil SS 6-32x.38
6	56002938	2	Wsh, Flt SAE SS 5/16
7	56003736	2	Scr, Hex Thd to Hd SS 5/16-18 x 3.00
8	56003472	2	Scr, Soc Shd .38 X 1.00 X 5/16-18
9	56009111	6	Nut, Wing SS 1/4-20
10	56109660	1	Strap-Left Rear "B" (used on 56315291) NOTE 2 / TSBUS2009-1037
	56109664	1	Strap-Left Rear "C" (used on 56315290) NOTE 2 / TSBUS2009-1037
	56109667	1	Strap-Left Rear "D" (used on 56315632) NOTE 2 / TSBUS2009-1037
11	56109661	1	Strap-Right Rear "B" (used on 56315291) NOTE 2 / TSBUS2009-1037
	56109665	1	Strap-Right Rear "C" (used on 56315290) NOTE 2 / TSBUS2009-1037
	56109668	1	Strap-Right Rear "D" (used on 56315632) NOTE 2 / TSBUS2009-1037
12	56314271	1	Squeegee Tool, Cast "B" (24")
	56314325	1	Squeegee Tool, Cast "C" (26" & 28")
	56314694	1	Squeegee Tool, Cast "D" (32")
13	56314028	1	Strap, Front "B" (24") NOTE 2
	56314322	1	Strap, Front "C" (26" & 28") NOTE 2
	56314696	1	Strap, Front "D" (32") NOTE 2
14	56315347	1	Squeegee Blade kit (24") NOTE 1
	56315348	1	Squeegee Blade kit (26" & 28") NOTE 1
	56315674	1	Squeegee Blade kit (32") NOTE 1
15	56471194	1	Latch Assembly / TSBUS2009-1037
			24" Squeegee Blade Kits
**	56315347	1	Kit, Gum Rubber Squeegee Blade NOTE 1
**	56315351	1	Kit, Linatex Squeegee Blade NOTE 1
**	56315854	1	Kit, Squeegee Blade PU B NOTE 1
			26" & 28" Squeegee Blade Kits
**	56315348	1	Kit, Gum Rubber Squeegee Blade NOTE 1
**	56315352	1	Kit, Linatex Squeegee Blade NOTE 1
**	56315855	1	Kit, Squeegee Blade PU C NOTE 1
			32" Squeegee Blade Kits
**	56315674	1	Kit, Gum Rubber Squeegee Blade NO
**	56314865	1	Kit, Linatex Squeegee Blade NOTE 1
**	56315856	1	Kit, Squeegee Blade PU D NOTE 1

** = Optional, Not Included

NOTE 1: All squeegee blade kits include both front and rear squeegee t

NOTE 2: To replace all squeegee straps as a set

order one of the three following Strap Kits:

56109669-Strap Kit-D (for Squeegee Assy 56315632)

56109666-Strap Kit-C (for Squeegee Assy 56315290)

56109662-Strap Kit-B (for Squeegee Assy 56315291)

These kits include both rear straps, front strap and the latch.

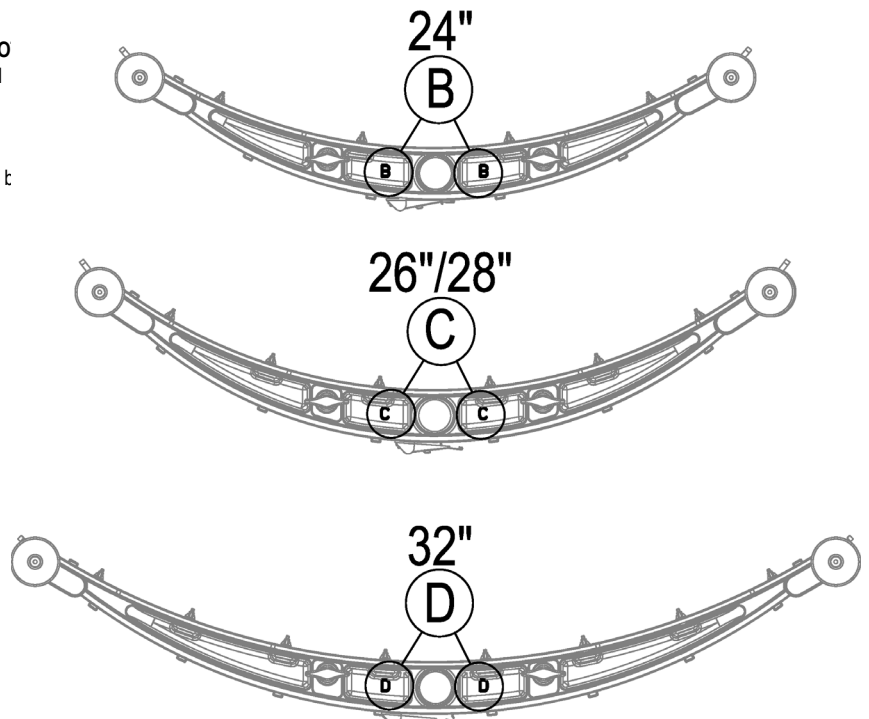

Item	Ref. No.	Qty	Description	Item	Ref. No.	Qty	Description
A1	56315297	1	Control Panel Assy (A1) NOTE 1	M5	56393303	1	Motor, Brush Actuator
	56315777	1	Control Panel Assy (A1) NOTE 2	*	56388520	1	Plastic Nut (for use on 56393303)
A2	56315294	1	Speed Control	M8	56315108	1	Pump, Solution
BT1	NA	4	Battery	M9	56315132	1	Pump, Chemical (Optional)
F1	56412089	1	Fuse, 150 Amp	M10	56315241	1	Pump, Recycle (Optional)
F2	56315255	1	Circuit Breaker, 5 Amp	R1	56397029	1	Potentiometer, 5K Ohm, Throttle
F3	56315256	1	Circuit Breaker, 30 Amp	R2	56396197	1	Potentiometer, 100K Ohm, Speed Limit
K1	56397088	1	Contactora, Brush Motor	S1	NA	1	Part of M7
K2	56412179	1	Contactora, Vac Motor	S2	NA	1	Part of M8
L1	56397203	1	Solenoid, Solution	S3	56303553	1	Switch, Key
L2	56397203	1	Solenoid, Recycle Solution (Optional)	*	56303526	A/R	Set of 2 Replacement Keys
M1	56315062	1	Transaxle, 24v	S4	56315096	1	Switch, Float
*	56315377	1	Motor	S5	56315096	1	Switch, Float (Optional / Recycle Start)
*	56315378	4	Carbon Brush	S6	56315096	1	Switch, Float (Optional / Recycle Stop)
*	56315379	2	Neoprene Mounting Sleeve	*	56315124	1	Charger, Onboard 24V (Onboard Charger Models Only) NOTE 3 TSBUS2006-931, TSBUS2008-1008
M2	56315056	1	Motor, Left Brush (Disk)	*	56315747	1	Thermistor Repair Kit for 56315124
*	56315376	4	Carbon Brush	*	56315340	1	Chemical Ratio Sensor (Chemical Models Only)
*	56397138	4	Brush Spring	*	56109674	1	Harness, Main TSBUS2006-926 / TSBUS2007-955
	56315061	1	Motor, Left Brush (Cylindrical) TSBUS2010-1058	*	56315751	1	Vacuum Harness TSBUS2007-955
*	56412287	1	Brush / Spring Kit	*	56416445	3	Cable Assy 4 AWG (Battery Cables)
M3	56315056	1	Motor, Right Brush (Disk)	*	56372673	8	Boot, Battery Post
*	56315376	4	Carbon Brush	*	56478523	2	Tie, Cable
*	56397138	4	Brush Spring	*	56478246	9	Tie, Cable
	56315061	1	Motor, Left Brush (Cylindrical) TSBUS2010-1058	*	56314119	1	Spacer, Battery
*	56412287	1	Brush / Spring Kit				
M4	56412218	1	Motor, Vac TSBUS2009-1036				
*	56397098	1	Carbon Brush set of 2 (for 56412218) NOTE 4				
*	56380529	1	Carbon Brush set of 2 (for 56412218) NOTE 4				

* = Not Shown

NOTE 1: Order this control panel assy if you have the "Old Pump" voltage reading across the solution pump (M8) leads.

NOTE 2: Order this control panel assy if you have the "New Pump" voltage reading across the solution pump (M8) leads.

	Voltage
Regular Scrub	
Old Pump	7
New Pump	9.56
Heavy Scrub	
Old Pump	11.3
New Pump	13.7
Extreme Scrub	
Old Pump	17
New Pump	19.24

NOTE 3: Starting with Charger serial # CP240548022382 the charger software can be programmed with a computer and the QuiQ Programmer kit 56315732.

NOTE 4: If your vacuum motor has a serial tag from Lamb Electric (Ametek) order Carbon Brush Set 56397098.

If your vacuum motor has a serial tag from Nilfisk-Advance order Carbon Brush Set 56380529.

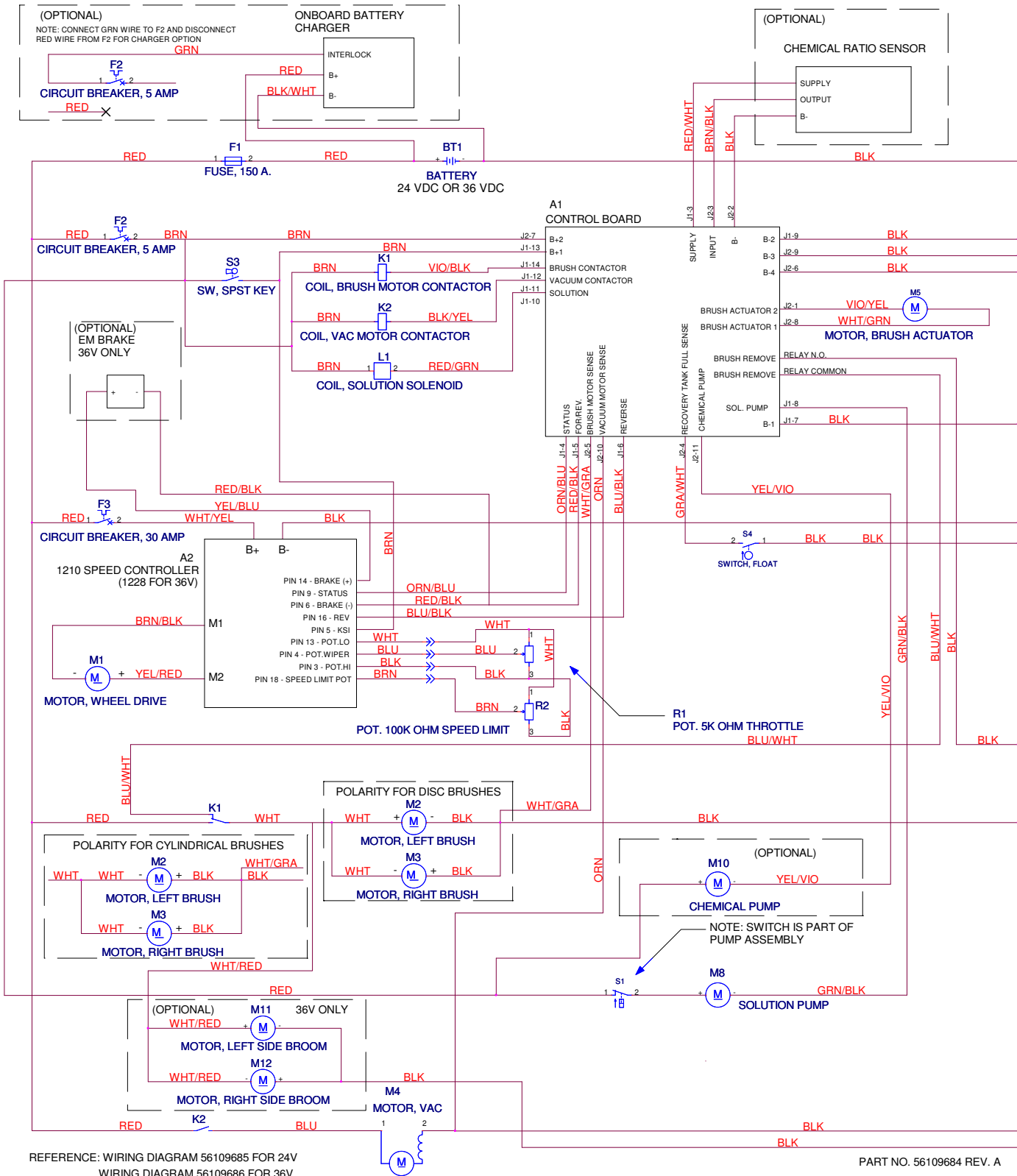

Item	Ref. No.	Qty	Description	Item	Ref. No.	Qty	Description
A1	56315777	1	Control Panel Assy (A1)	*	56315124	1	Charger, Onboard 24V (Onboard Charger Models Only) NOTE 3
A2	56315294	1	Speed Control				TSBUS2006-931, TSBUS2008-1008
BT1	NA	4	Battery				
F1	56412089	1	Fuse, 150 Amp	*	56315747	1	Thermistor Repair Kit for 56315124
F2	56315255	1	Circuit Breaker, 5 Amp	*	56315340	1	Chemical Ratio Sensor (Chemical Models Only)
F3	56315256	1	Circuit Breaker, 30 Amp	*	56109674	1	Harness, Main TSBUS2006-926 / TSBUS2007-955
K1	56397088	1	Contactora, Brush Motor	*	56315751	1	Vacuum Harness TSBUS2007-955
K2	56412179	1	Contactora, Vac Motor	*	56416445	3	Cable Assy 4 AWG (Battery Cables)
L1	56397203	1	Solenoid, Solution	*	56372673	8	Boot, Battery Post
M1	56315062	1	Transaxle, 24v	*	56478523	2	Tie, Cable
*	56315377	1	Motor	*	56478246	9	Tie, Cable
*	56315378	4	Carbon Brush	*	56314119	1	Spacer, Battery
*	56315379	2	Neoprene Mounting Sleeve				
M2	56315056	1	Motor, Left Brush (Disk)	* = Not Shown			
*	56315376	4	Carbon Brush				
*	56397138	4	Brush Spring				
	56315061	1	Motor, Left Brush (Cylindrical) TSBUS2010-1058				
*	56412287	1	Brush / Spring Kit (for 56315061) NOTE 2				
*	56380003	1	Brush / Spring Kit (for 56315061) NOTE 2				
M3	56315056	1	Motor, Right Brush (Disk)				
*	56315376	4	Carbon Brush				
*	56397138	4	Brush Spring				
	56315061	1	Motor, Left Brush (Cylindrical) TSBUS2010-1058				
*	56412287	1	Brush / Spring Kit (for 56315061) NOTE 2				
*	56380003	1	Brush / Spring Kit (for 56315061) NOTE 2				
M4	56412218	1	Motor, Vac TSBUS2009-1036				
*	56397098	1	Carbon Brush set of 2 (for 56412218) NOTE 1				
*	56380529	1	Carbon Brush set of 2 (for 56412218) NOTE 1				
M5	56109597	1	Motor, Brush Actuator				
*	56109596	1	Plastic Nut (for use on 56109597)				
M8	56315108	1	Pump, Solution				
M10	56315241	1	Pump, Chemical (Optional)				
R1	56397029	1	Potentiometer, 5K Ohm, Throttle				
R2	56396197	1	Potentiometer, 100K Ohm, Speed Limit				
S1	NA	1	Part of M8				
S3	56303553	1	Switch, Key				
*	56303526	A/R	Set of 2 Replacement Keys				
S4	56315096	1	Switch, Float				

NOTE 1: If your vacuum motor has a serial tag from Lamb Electric (Ametek) order Carbon Brush Set 56397098.

If your vacuum motor has a serial tag from Nilfisk-Advance order Carbon Brush Set 56380529.

NOTE 2: If your cylindrical scrub motor has a serial tag from Scott Motors Co. (4BB1344) order Carbon Brush Set 56412287.

If your cylindrical scrub motor has a serial tag from Nilfisk-Advance (ZD22000) order Carbon Brush Set 56380003.

OPTIONAL KITS AND ACCESSORIES

04-11

32

Convertamatic™

11-1

Ref. No.	Qty	Description	Ref. No.	Qty	Description
Kits			28" Disk Scrub Brushes		
**	56315312	1 Squeegee Wand Kit	**	56505800	2 Short Trim Pad Holder
**	56315732	1 QuiQ Programmer Kit NOTE 2 TSBUS2007-979	**	56505195	2 Pad Retainer for 56505750
**	56315322	A/R Kit, 24" Disk Deck Assy	**	56505801	2 MagnaGrit
**	56315323	A/R Kit, 26" Disk Deck Assy	**	56505802	2 DynaGrit
**	56315324	A/R Kit, 28" Disk Deck Assy	**	56505803	2 AgLite
**	56315864	A/R Kit, 32" Disk Deck Assy	**	56505804	2 Prolene
**	56315325	A/R Kit, 24" Cyl Deck Assy	**	56505805	2 ProLite
**	56315326	A/R Kit, 26" Cyl Deck Assy	**	56505806	2 Union Mix
**	56315327	A/R Kit, 28" Cyl Deck Assy	**	56505807	2 MidGrit
			**	56505808	2 MidLite Grit
24" Squeegee Kits			32" Disk Scrub Brushes		
**	56315347	1 Kit, Gum Rubber Squeegee Blade NOTE 1	**	56505830	2 Short Trim Pad Holder
**	56315351	1 Kit, Linatex Squeegee Blade NOTE 1	**	56505195	2 Pad Retainer for 56505750
**	56315854	1 Kit, Squeegee Blade PU B NOTE 1	**	56505831	2 MagnaGrit
**	56109662	1 Strap Kit-B	**	56505832	2 DynaGrit
26" & 28" Squeegee Kits			**	56505833	2 AgLite
**	56315348	1 Kit, Gum Rubber Squeegee Blade NOTE 1	**	56505834	2 Prolene
**	56315352	1 Kit, Linatex Squeegee Blade NOTE 1	**	56505835	2 ProLite
**	56315855	1 Kit, Squeegee Blade PU C NOTE 1	**	56505836	2 Union Mix
**	56109666	1 Strap Kit-C	**	56505837	2 MidGrit
			**	56505838	2 MidLite Grit
32" Squeegee Kits			24" Cylindrical Scrub Brushes		
**	56315674	1 Kit, Gum Rubber Squeegee Blade NOTE 1	**	56314389	2 Soft Nylon
**	56314865	1 Kit, Linatex Squeegee Blade NOTE 1	**	56314390	2 Hard Nylon
**	56315856	1 Kit, Squeegee Blade PU D NOTE 1	**	56314391	2 Prolene
**	56109669	1 Strap Kit-D	**	56314392	2 180 Grit
Common Accessories			**	56314393	2 80 Grit
**	56315316	A/R Tote Bag	**	56314394	2 46 Grit
**	56409441	A/R Programmer, 1307 User	26" Cylindrical Scrub Brushes		
**	56409823	A/R Programmer Cable	**	56314383	2 Soft Nylon
**	56397453	6 Indicator, Battery Level (1 per battery)	**	56314384	2 Hard Nylon
**#	56044331	1 Literature Pack	**	56314385	2 Prolene
Optional Batteries			**	56314386	2 180 Grit
**	56206987	4 Battery, 6V 180AH Gel TSBUS2008-984	**	56314387	2 80 Grit
**	56206117	4 Battery, 6V 195AH Wet TSBUS2008-984	**	56314388	2 46 Grit
**	56206079	4 Battery, 6V 235AH Wet TSBUS2008-984	28" Cylindrical Scrub Brushes		
**	56315772	4 Battery, 6V 255AH AGM TSBUS2008-984	**	56412191	2 Soft Nylon
Optional Battery Chargers			**	56412192	2 Hard Nylon
**	56388109	A/R Charger, 24V 25A 110V TSBUS2008-984	**	56412046	2 Prolene
24" Disk Scrub Brushes			**	56412193	2 180 Grit
**	56505750	2 Short Trim Pad Holder	**	56412194	2 80 Grit
**	56505195	2 Pad Retainer for 56505750	**	56412195	2 46 Grit
**	56505751	2 MagnaGrit	* = Not Shown		
**	56505752	2 DynaGrit	** = Optional, Not Included		
**	56505753	2 AgLite	# = Revised or new since last update		
**	56505754	2 Prolene	NOTE 1: All squeegee blade kits include both front and rear squeegee blades.		
**	56505755	2 ProLite	NOTE 2: Starting with Charger serial # CP240548022382 the charger software can be programmed with a computer and the QuiQ Programmer kit 56315732.		
**	56505756	2 Union Mix			
**	56505757	2 MidGrit			
**	56505758	2 MidLite Grit			
26" Disk Scrub Brushes					
**	56505760	2 Short Trim Pad Holder			
**	56505195	2 Pad Retainer for 56505750			
**	56505761	2 MagnaGrit			
**	56505762	2 DynaGrit			
**	56505763	2 AgLite			
**	56505764	2 Prolene			
**	56505765	2 ProLite			
**	56505766	2 Union Mix			
**	56505767	2 MidGrit			
**	56505768	2 MidLite Grit			

We provide brushes and pad holders that will give you the best possible performance between machine and floor. Following are descriptions of the materials and their applications.

Union Mix:	Medium grade natural fibers for polishing finished floors with standard-speed equipment. Recommended for use in place of white pads.
ProLite:	Bristles are made from light-duty polypropylene for general scrubbing when you do not want to scratch or remove finish from the floor. Recommended for use in place of red pads.
Prolene:	Polypropylene material for medium-duty scrubbing on concrete, terrazzo and vinyl floor tile. Recommended for use in place of green or blue pads.
Magna Grit:	For extreme heavy-duty scrubbing or stripping of floors. This brush has extra large diameter silicon carbide grit impregnated synthetic bristles. Recommended for use in place of black pads.
Dyna Grit:	For aggressive, heavy-duty scrubbing or stripping of floors. Recommended for use in place of brown pads.
MidLite Grit:	For general purpose scrubbing of sealed or unsealed concrete, stone, terrazzo, quarry tile and other resilient hard floor surfaces. Recommended for use in place of green or blue pads.
MidGrit:	For general purpose scrubbing when you need a lighter action for sealed or unsealed concrete, stone, terrazzo, quarry tile and other resilient hard floor surfaces. Recommended for use in place of green or blue pads.
AgLite Grit:	For light scrubbing when used wet; buffing or polishing when used dry on urethane coated, sealed concrete or other resilient hard surface floors. Recommended for use in place of red or white pads.
Short Trim	
Pad Holder:	Made with a structural foam block and center ring for correct pad centering. It has a "shower feed" design for getting solution to the floor.

24" BRUSHES

56505750 - Short Trim Pad Holder
 56505195 - Pad Retainer for 56505750
 56505751 - MagnaGrit
 56505752 - DynaGrit
 56505753 - AgLite
 56505754 - Prolene
 56505755 - ProLite
 56505756 - Union Mix
 56505757 - MidGrit
 56505758 - MidLite Grit

26" BRUSHES

56505760 - Short Trim Pad Holder
 56505195 - Pad Retainer for 56505760
 56505761 - MagnaGrit
 56505762 - DynaGrit
 56505763 - AgLite
 56505764 - Prolene
 56505765 - ProLite
 56505766 - Union Mix
 56505767 - MidGrit
 56505768 - MidLite Grit

28" BRUSHES

56505800 - Short Trim Pad Holder
 56505195 - Pad Retainer for 56505800
 56505801 - MagnaGrit
 56505802 - DynaGrit
 56505803 - AgLite
 56505804 - Prolene
 56505805 - ProLite
 56505806 - Union Mix
 56505807 - MidGrit
 56505808 - MidLite Grit

32" BRUSHES

56505830 - Short Trim Pad Holder
 56505195 - Pad Retainer for 56505800
 56505831 - MagnaGrit
 56505832 - DynaGrit
 56505833 - AgLite
 56505834 - Prolene
 56505835 - ProLite
 56505836 - Union Mix
 56505837 - MidGrit
 56505838 - MidLite Grit

DISC BRUSH APPLICATION GUIDE (SUGGESTION ONLY)

Application	46 Grit	80 Grit	180 Grit	240 Grit	500 Grit	Prolene	Prolite	Union Mix
Stripping:								
Concrete	X	X						
Terrazzo	X	X						
Ceramic/Quarry tile		X						
Vinyl tile		X						
General Scrubbing:								
Concrete	X	X	X	X		X		
Terrazzo			X	X	X	X		
Ceramic/Quarry tile			X	X	X	X		
Marble					X		X	
Vinyl tile			X		X	X		
Raised-rubber tile					X		X	
Polishing:								
Raised Disc Tile								X
Marble								X
Vinyl tile								X

We provide brushes and pad holders that will give you the best possible performance between machine and floor. Following are descriptions of the materials and their applications.

- 46 Grit Brush:** Most aggressive grit brush. Used primarily to clean heavy buildup on concrete floors in factories, or for heavy stripping of finish.
- 80 Grit Brush:** Medium aggressive grit brush. Good all-around brush for medium to heavy buildup removal. Can also be used for general stripping operations.
- 180 Grit Brush:** Least aggressive grit brush. Used for daily cleaning of hard-finished floors.
- Polypropylene Brush:** Standard equipment brush. Low cost, yet effective in cleaning many common floor surfaces.
- Stiff Nylon Brush:** Cleaning action similar to polypropylene. More durable and wear-resistant than polypropylene.
- Soft Nylon Brush:** Least aggressive brush available. Used on soft-finish floors where a more aggressive brush would leave scratch marks, or in applications requiring very light cleaning.

24" BRUSHES

56314389 - Soft Nylon
 56314390 - Hard Nylon
 56314391 - Prolene
 56314392 - 180 Grit
 56314393 - 80 Grit
 56314394 - 46 Grit

26" BRUSHES

56314383 - Soft Nylon
 56314384 - Hard Nylon
 56314385 - Prolene
 56314386 - 180 Grit
 56314387 - 80 Grit
 56314388 - 46 Grit

28" BRUSHES

56412191 - Soft Nylon
 56412192 - Hard Nylon
 56412046 - Prolene
 56412193 - 180 Grit
 56412194 - 80 Grit
 56412194 - 46 Grit

CYLINDRICAL BRUSH APPLICATION GUIDE (SUGGESTION ONLY)

Application	46 Grit	80 Grit	180 Grit	Polypropylene	Stiff Nylon	Soft Nylon
Stripping:						
Concrete	X	X				
Terrazzo	X	X				
Ceramic/Quarry tile		X				
Vinyl tile		X				
General Scrubbing:						
Concrete	X	X	X	X	X	
Terrazzo			X	X	X	X
Ceramic/Quarry tile			X	X	X	X
Marble			X		X	X
Vinyl tile			X	X	X	X
Raised-rubber tile			X			X



14600 21st Avenue North
Plymouth, MN 55447-3408
www.advance-us.com
Phone: 800-989-2235
Fax: 800-989-6566
©2011 Nilfisk-Advance, Inc.

A Nilfisk-Advance Brand