



## Electronic Service Manuals

This electronic document is provided as a service to our customers. We do not create the contents of the information contained in this document. Should you have detailed questions pertaining to the information contained in this document, you may contact Michco, or the manufacturer which provided the original information in this electronic deliverable. Michco's only part in this electronic deliverable was the electronic assembly process. By providing this manual on line we are not guaranteeing parts availability.

You may contact Michco through the following methods:

Phone (517) 484-9312 or (800) 331-3339

2011 N. High St. -- Lansing, Michigan -- 48906

Fax: (517) 484-9836

Email: [CustServe@Michco.com](mailto:CustServe@Michco.com)

Web site: [www.Michco.Com](http://www.Michco.Com)

Parts Web site: [www.FloorMachineParts.Com](http://www.FloorMachineParts.Com)

Order Parts on Line at:

**[www.FloorMachineParts.Com](http://www.FloorMachineParts.Com)**

Directly to Parts & Service:

By Email: **[Shop@Michco.com](mailto:Shop@Michco.com)**

By Fax: (517) 702-2041

By Voice: Use numbers above.

**Serving the Cleaning Industry Since 1922**

Notice: All copyrighted material remains property of original owners, all trademarks are property of respective owners. Manuals are subject to Manufacturer's reproduction limitations. Originals or reproductions were provided by manufacturers through a request. We make no warranty as to the correctness of information provided in this document and you assume all risk. By placing these manuals on line we are not declaring our corporation to be an manufacturer authorized dealer or provider, please check our web site for authorized manufacturers we represent.



# 5300

Automatic Scrubber

Model No.:  
300000PAC  
300000  
603053  
606445

Operator and Parts Manual

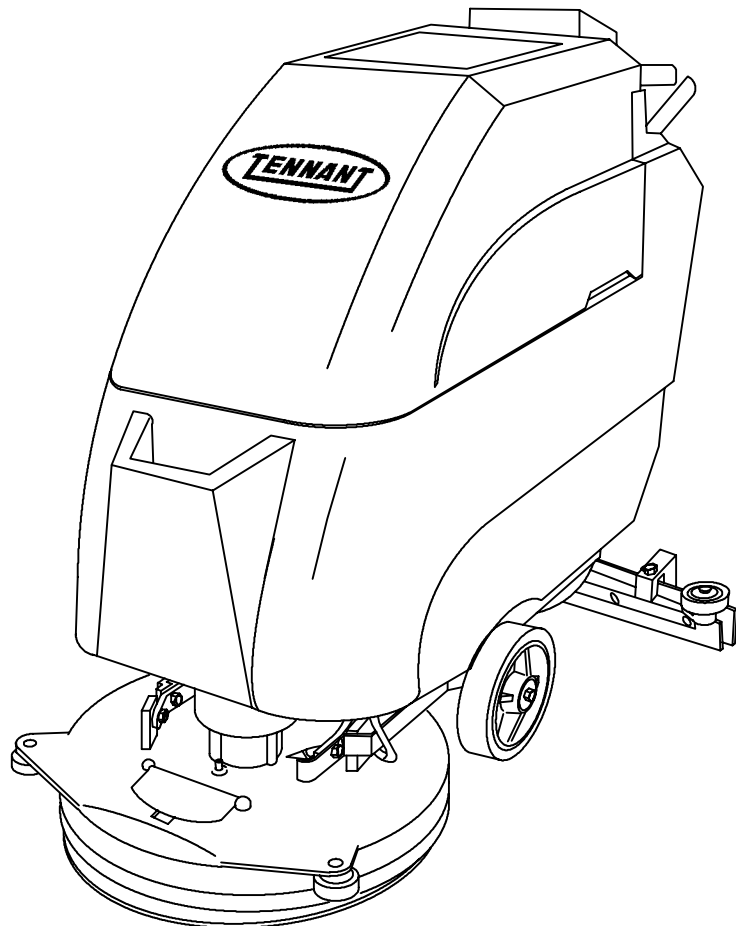

173420  
Rev. 07 (11-04)

# OPERATION

---

This manual is furnished with each new model. It provides necessary operation and maintenance instructions and an illustrated parts list.

**Read this manual completely and understand the machine before operating or servicing it.**

When ordering replacement parts, use the illustrated parts lists section in this manual. Before ordering parts or supplies, be sure to have your machine model number and serial number available. Parts and supplies may be ordered by phone or mail from any authorized parts and service center, distributor or from any of the manufacturer's subsidiaries.

This machine will provide excellent service. However, the best results will be obtained at minimum costs if:

- The machine is operated with reasonable care.
- The machine is maintained regularly - per the machine maintenance instructions provided.
- The machine is maintained with manufacturer supplied or equivalent parts.

---

## MACHINE DATA

---

Please fill out at time of installation for future reference.

Model No.- \_\_\_\_\_

Install. Date - \_\_\_\_\_

Serial No.- \_\_\_\_\_

©1995, 1999, 2000, 2001, 2002, 2004 Tennant Company

Printed in U.S.A

Specifications and parts are subject to change without notice.

**Tennant Company**

PO Box 1452

Minneapolis, MN 55440

Phone: (800) 553-8033 or (763) 513-2850

[www.tennantco.com](http://www.tennantco.com)

**TABLE OF CONTENTS**

<b>SAFETY PRECAUTIONS</b> .....	<b>4</b>	<b>SCRUB HEAD</b> .....	<b>30</b>
<b>SAFETY LABELS</b> .....	<b>5</b>	ADJUSTING THE SCRUB HEAD SKIRT .....	30
<b>MACHINE COMPONENTS</b> .....	<b>6</b>	REPLACING THE SCRUB HEAD SKIRT .....	31
<b>CONTROL PANEL SYMBOLS</b> .....	<b>7</b>	REPLACING THE SCRUB BRUSH .....	31
<b>CONTROLS AND INSTRUMENTS</b> .....	<b>8</b>	<b>SQUEEGEE</b> .....	<b>32</b>
STEERING HANDLES/BRUSH AND		REMOVING THE SQUEEGEE .....	32
SOLUTION ON SWITCH .....	9	INSTALLING THE SQUEEGEE .....	33
BATTERY DISCHARGE INDICATOR .....	9	LEVELING THE SQUEEGEE .....	33
SPEED SWITCH .....	10	ADJUSTING SQUEEGEE DOWN PRESSURE .....	33
BRUSH PRESSURE GAUGE .....	10	ADJUSTING SQUEEGEE BLADE DEFLECTION .....	34
MACHINE POWER SWITCH .....	10	<b>SQUEEGEE BLADES</b> .....	<b>34</b>
SOLUTION SWITCH .....	10	REPLACING OR ROTATING THE FRONT	
ES (EXTENDED SCRUB) PUMP ON LIGHT		SQUEEGEE BLADE .....	34
(OPTION) .....	11	REPLACING OR ROTATING THE REAR	
ES (EXTENDED SCRUB) SWITCH (OPTION) .....	11	SQUEEGEE BLADE .....	35
POWER WAND SWITCH (OPTION) .....	11	<b>MACHINE JACKING</b> .....	<b>35</b>
HOUR METER (OPTION) .....	11	<b>TRANSPORTING MACHINE</b> .....	<b>35</b>
ON-OFF KEY SWITCH (OPTION) .....	11	<b>STORAGE INFORMATION</b> .....	<b>36</b>
CIRCUIT BREAKERS .....	12	FREEZE PROTECTION .....	36
FUSE .....	12	<b>RECOMMENDED STOCK ITEMS</b> .....	<b>36</b>
POWER KILL SWITCH (OPTION) .....	12	<b>MACHINE DIMENSIONS</b> .....	<b>36</b>
SOLUTION FLOW KNOB .....	12	<b>TROUBLESHOOTING</b> .....	<b>37</b>
BRUSH PRESSURE KNOB .....	13	<b>SPECIFICATIONS</b> .....	<b>38</b>
SOLUTION TANK HOSE .....	13	<b>ELECTRICAL DIAGRAMS</b> .....	<b>40</b>
RECOVERY TANK DRAIN HOSE .....	13	<b>PARTS LIST</b> .....	<b>42</b>
SQUEEGEE LEVER .....	13	REPLACEMENT BRUSHES AND	
STOP ARM .....	14	PAD DRIVER GROUP .....	42
SCRUB HEAD PEDALS .....	14	SOLUTION TANK AND VACUUM MOTOR GROUP ..	44
SQUEEGEE DOWN PRESSURE KNOB .....	14	SOLUTION CONTROL GROUP .....	46
SQUEEGEE LEVELING KNOB .....	14	RECOVERY TANK GROUP .....	48
<b>HOW THE MACHINE WORKS</b> .....	<b>15</b>	CONSOLE GROUP .....	50
<b>MACHINE INSTALLATION</b> .....	<b>15</b>	CONSOLE PANEL GROUP .....	52
INSTALLING BATTERIES .....	15	MAIN FRAME GROUP .....	54
<b>PRE-OPERATION CHECKLIST</b> .....	<b>16</b>	SCRUB HEAD LIFT GROUP .....	56
<b>STARTING THE MACHINE</b> .....	<b>16</b>	SCRUB BRUSH DRIVE GROUP .....	58
<b>FILLING THE TANKS</b> .....	<b>16</b>	SCRUB BRUSH DOWN PRESSURE GROUP .....	60
<b>NORMAL SCRUBBING AND ES (EXTENDED SCRUB)</b>		SQUEEGEE LIFT GROUP .....	62
<b>SCRUBBING</b> .....	<b>17</b>	SQUEEGEE GROUP .....	64
<b>DOUBLE SCRUBBING</b> .....	<b>19</b>	BATTERY AND CHARGER GROUP .....	66
<b>STOP SCRUBBING</b> .....	<b>19</b>	BATTERY CABLE GROUP .....	67
<b>DRAINING AND CLEANING THE TANKS</b> .....	<b>19</b>	ELECTRIC MOTOR BREAKDOWN .....	68
<b>STOP THE MACHINE</b> .....	<b>22</b>	<b>OPTIONS</b> .....	<b>69</b>
<b>OPERATION ON INCLINES</b> .....	<b>22</b>	WET PICK-UP TOOL KIT .....	69
<b>POST-OPERATION CHECKLIST</b> .....	<b>22</b>	NON-POWER WAND ASSEMBLY .....	70
<b>CHARGING BATTERIES</b> .....	<b>23</b>	POWER WAND ASSEMBLY .....	71
<b>OPTIONS</b> .....	<b>24</b>	DELUXE POWER WAND ASSEMBLY .....	72
VACUUM WAND .....	24	NON-POWER WAND HOSE ASSEMBLY .....	74
POWER WAND .....	26	POWER WAND HOSE ASSEMBLY .....	75
<b>MACHINE MAINTENANCE</b> .....	<b>28</b>	ACCESSORY CONSOLE GROUP .....	76
DAILY MAINTENANCE .....	28	WAND PUMP PLUMBING GROUP .....	78
MONTHLY MAINTENANCE .....	29	ES (EXTENDED SCRUB) PLUMBING GROUP .....	79
QUARTERLY MAINTENANCE .....	29	SOUND KIT .....	80
BATTERY MAINTENANCE .....	29		

# OPERATION

---

---

## SAFETY PRECAUTIONS

---

This machine is intended for commercial use. It is designed exclusively to scrub hard floors in an indoor environment and is not constructed for any other use. Use only recommended pads, brushes and commercially approved floor cleaners intended for machine application.

All operators must read, understand and practice the following safety precautions.

The following warning alert symbol and the "FOR SAFETY" heading are used throughout this manual as indicated in their description:

 **WARNING:** To warn of hazards or unsafe practices which could result in severe personal injury or death.

**FOR SAFETY:** To identify actions which must be followed for safe operation of equipment.

---

Failure to follow these warnings may result in personal injury, electrical shock, fire or explosion.

 **WARNING:** Fire Or Explosion Hazard:

- **Never Use Flammable Liquids Or Operate Machine in Or Near Flammable Liquids, Vapors Or Combustible Dusts.**

*This machine is not equipped with explosion proof motors. The electric motors will spark upon start up and during operation which could cause a flash fire or explosion if machine is used in an area where flammable vapors/liquids or combustible dusts are present.*

- **Do Not Pick Up Flammable Materials Or Reactive Metals.**
- **Batteries Emit Hydrogen Gas. Keep Sparks And Open Flame Away. Keep Battery Compartment Open When Charging.**

 **WARNING:** Electrical Hazard. Disconnect Battery Cables Before Servicing Machine.

 **WARNING:** Spinning Brush. Keep Hands Away. Turn Off Power Before Working On Machine.

---

The following information signals potentially dangerous conditions to the operator or equipment:

### FOR SAFETY:

1. **Do not operate machine:**
  - With flammable liquids or near flammable vapors as an explosion or flash fire may occur.
  - Unless trained and authorized.
  - Unless operator manual is read and understood.
  - If not in proper operating condition.
2. **Before operating machine:**
  - Make sure all safety devices are in place and operate properly.
3. **When using machine:**
  - Go slow on inclines and slippery surfaces.
  - Wear non-slip shoes.
  - Use care when reversing machine.
  - Reduce speed when turning.
  - Report machine damage or faulty operation immediately.
  - Never allow children to play on or around.
  - Follow mixing and handling instructions on chemical containers.
4. **Before leaving or servicing machine:**
  - Stop on level surface.
  - Turn off machine.
5. **When servicing machine:**
  - Avoid moving parts. Do not wear loose jackets, shirts, or sleeves.
  - Use hoist or jack that will support the weight of the machine.
  - Disconnect battery connections before working on machine.
  - Wear protective gloves and eye protection when handling batteries or battery cables.
  - Avoid contact with battery acid.
  - Do not power spray or hose off machine. Electrical malfunction may occur.
  - Use manufacturer supplied or approved replacement parts.
  - All repairs must be performed by a qualified service person.
  - Do not modify the machine from its original design.

6. When transporting machine:

- Turn machine off.
- Do not lift machine when batteries are installed.
- Get assistance when lifting machine.
- Use a recommended ramp when loading/unloading into/off truck or trailer.
- Use tie-down straps to secure machine to truck or trailer.
- Put scrub head in the lowered position.

**NOTICE TO OWNERS:**

The foam filled tire option must be installed in place of the solid tires when the machine is used consistently on grouted tile floors to prevent tile damage and excessive machine component wear. Foam filled tires should also be used on soft surfaces such as sports floors to reduce wheel marking of surface.

**ATTENTION: Usage of solid tires in the above conditions will void the warranty on drive system components.**

**SAFETY LABELS**

The safety labels appear on the machine in the locations indicated. Replace labels if they are missing or become damaged or illegible.

**WARNING LABEL -**

Located on the recovery tank cover.



**READ MANUAL LABEL -**

Located on control panel.

**FOR SAFETY: Do not operate machine unless operator manual is read and understood.**

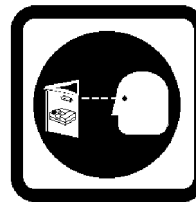

**MOVING PARTS LABEL -**

Located on scrub head

**WARNING: Spinning Brush. Keep Hands Away. Turn Off Power Before Working On Machine.**

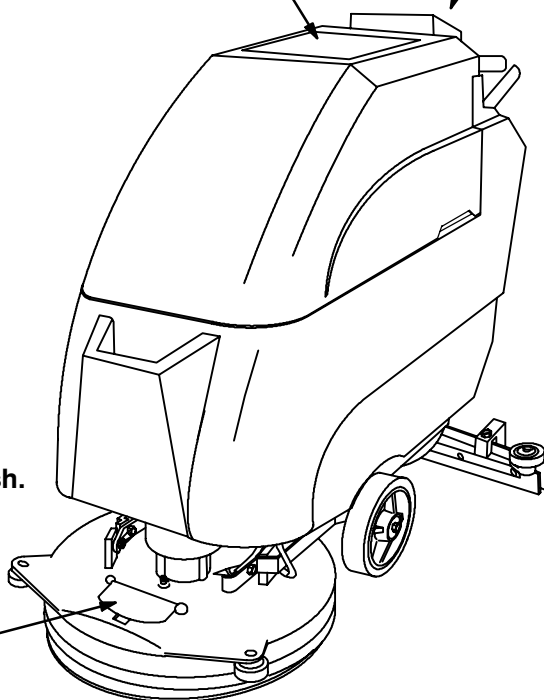

# OPERATION

## MACHINE COMPONENTS

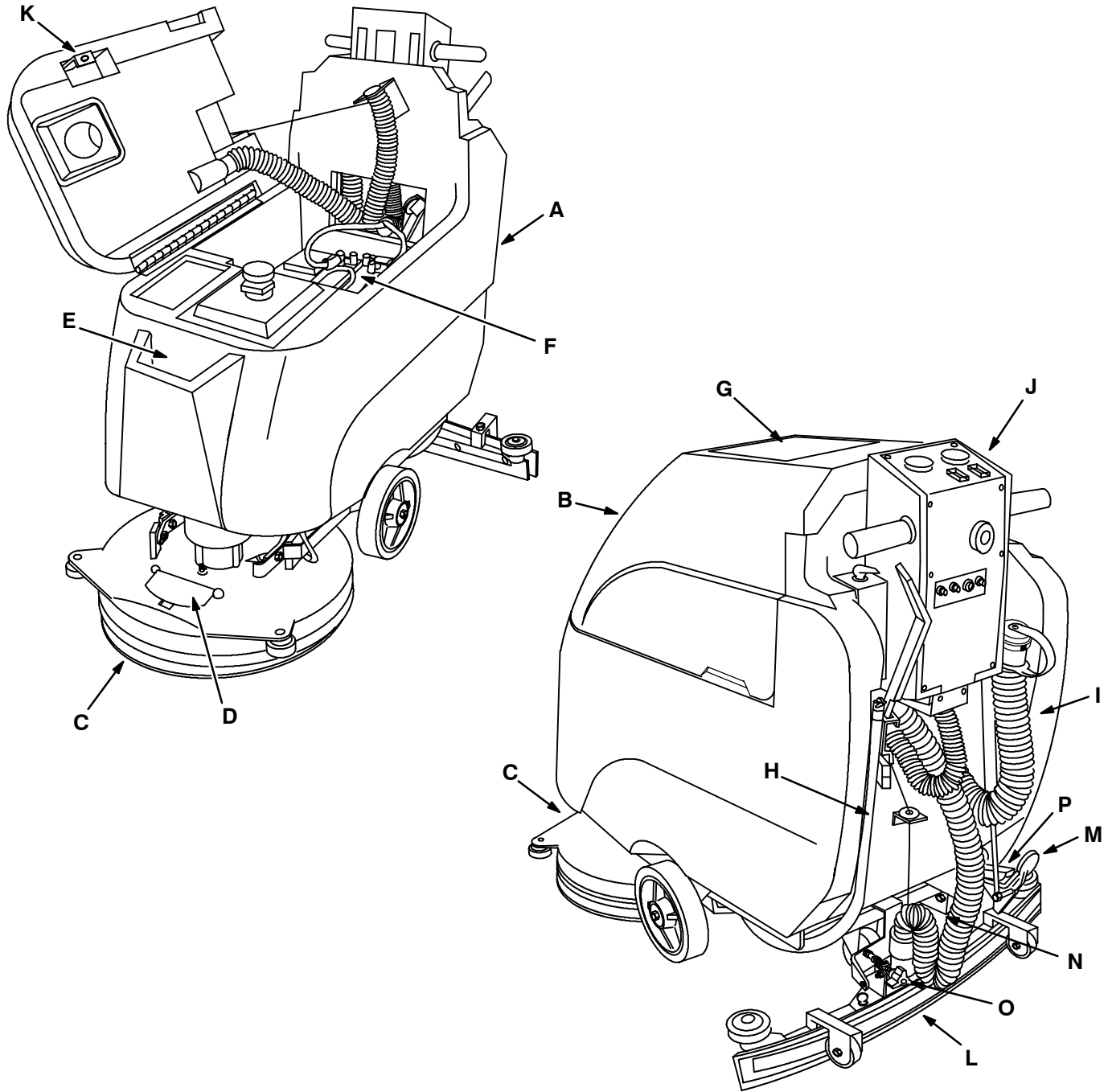

- A. Solution Tank
- B. Recovery Tank
- C. Scrub Head
- D. Scrub Head Access Cover
- E. Solution Tank Fill Opening
- F. Batteries
- G. Recovery Tank Cover
- H. Solution Tank Hose

- I. Recovery Tank Drain Hose
- J. Console Panel
- K. Stop Arm
- L. Squeegee
- M. Scrub Head Lift Pedal
- N. Squeegee Down Pressure Knob
- O. Squeegee Leveling Knob
- P. Scrub Head Release Pedal

---

## CONTROL PANEL SYMBOLS

---

These symbols are used to identify controls and displays on the machine:



Slow



Fast

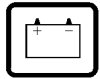

Battery Charge



Light Brush Pressure



Heavy Brush Pressure



Machine Power



Solution Flow



Hourmeter



Extended Scrub (Option)

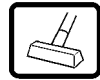

Power Wand or Vacuum Wand



Recovery Tank Full



Key Switch



Propelling Circuit Breaker



Scrub Brush Circuit Breaker



Machine Power Circuit Breaker



Vacuum Fan Circuit Breaker

# OPERATION

## CONTROLS AND INSTRUMENTS

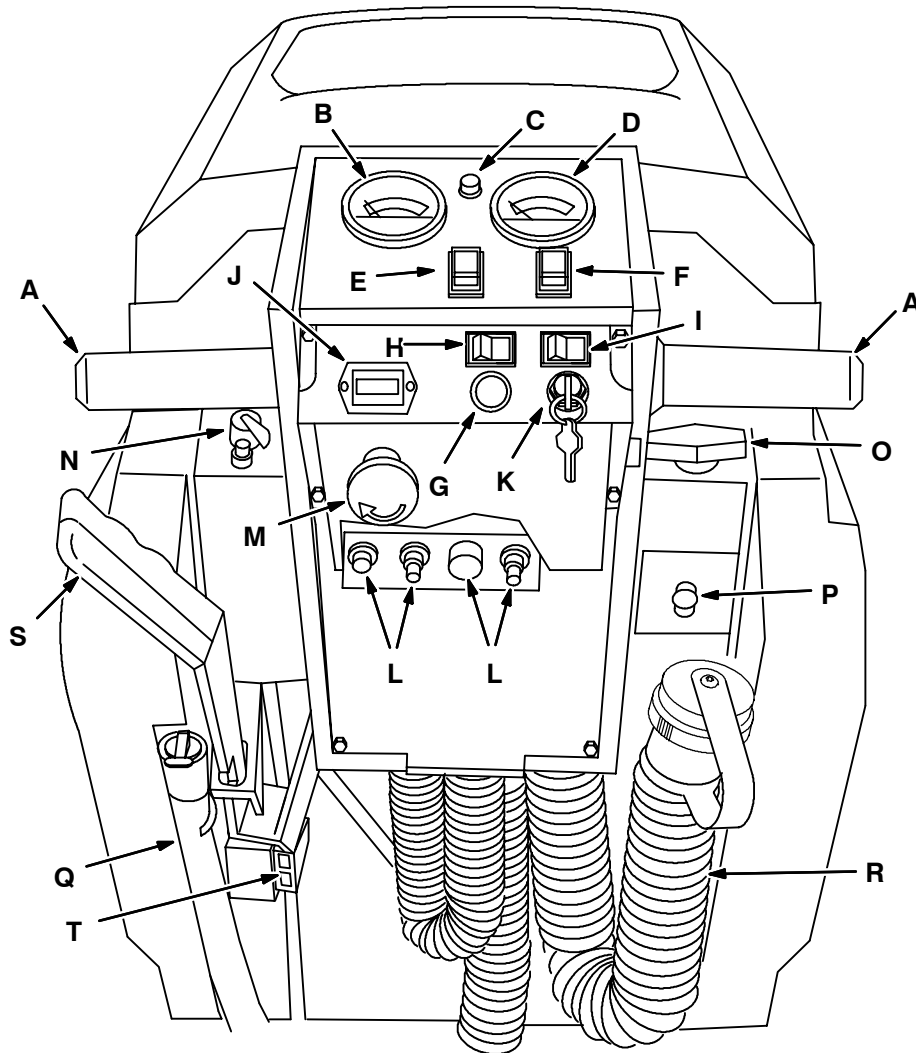

- |   |                                      |
|---|--------------------------------------|
| <b>A. Steering Handles/Brush and Solution On Switch</b> | <b>K. On-off Key Switch (Option)</b> |
| <b>B. Battery Discharge Indicator</b>                   | <b>L. Circuit Breakers</b>           |
| <b>C. Speed Switch</b>                                  | <b>M. Power Kill Switch (Option)</b> |
| <b>D. Brush Pressure Gauge</b>                          | <b>N. Solution Flow Knob</b>         |
| <b>E. Machine Power Switch</b>                          | <b>O. Brush Pressure Knob</b>        |
| <b>F. Solution Switch</b>                               | <b>P. Brush Pressure Indicator</b>   |
| <b>G. Pump On Light (Option)</b>                        | <b>Q. Solution Tank Hose</b>         |
| <b>H. ES (Extended Scrub) Switch (Option)</b>           | <b>R. Recovery Tank Drain Hose</b>   |
| <b>I. Power Wand Switch (Option)</b>                    | <b>S. Squeegee Lever</b>             |
| <b>J. Hourmeter (Option)</b>                            | <b>T. Charger Plug</b>               |

## STEERING HANDLES/BRUSH AND SOLUTION ON SWITCH

The steering handles control the machine direction, and the brush and solution flow is operated by twisting the steering handles.

Forward/Brush and Solution On: Twist the handles forward.

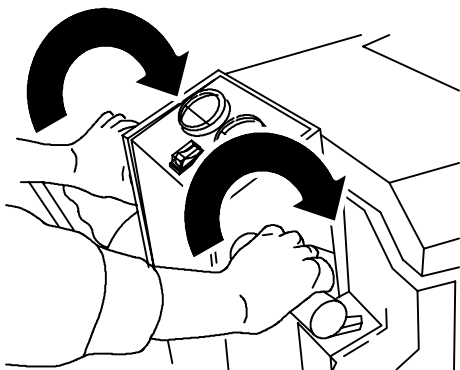

Backward/Brush and Solution On: Twist the handles toward you.

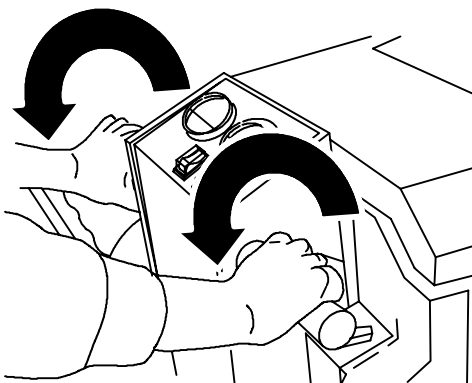

Turning: Push the machine in the direction of the turn with the steering handles. The machine will turn on the swivel casters.

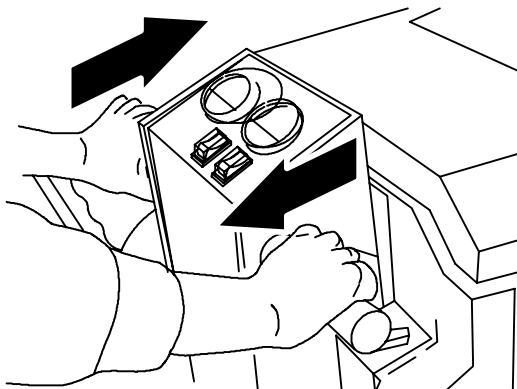

Stopping/Brush and Solution Off: Release the handles.

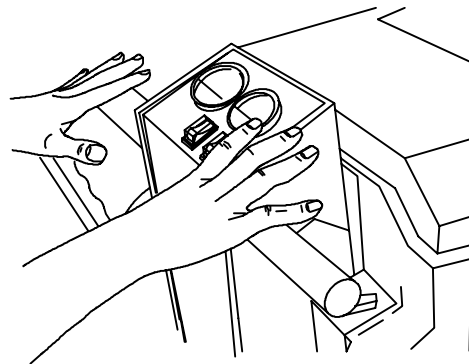

The steering handles and console height is adjustable.

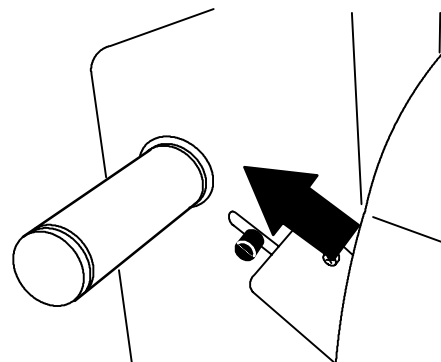

Adjust: Pull up on the height adjustment lever, move the console up or down, then release the lever.

## BATTERY DISCHARGE INDICATOR

The battery discharge indicator shows the charge level of the batteries. The meter's needle should be at the top of the **green** zone when the batteries are fully charged. As the batteries discharge, the needle will move into the bottom **red** zone. Recharge the batteries when the needle remains in the bottom **red** zone.

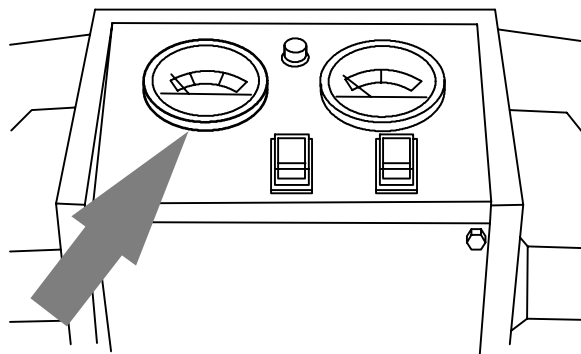

If the needle remains in the top red zone, the batteries have been overcharged.

**NOTE:** The reading on the battery discharge indicator is not accurate when the machine is first powered on. Operate the machine a few minutes before reading the charge level of the batteries.

# OPERATION

---

## SPEED SWITCH

The speed switch allows variable forward speed of the machine.

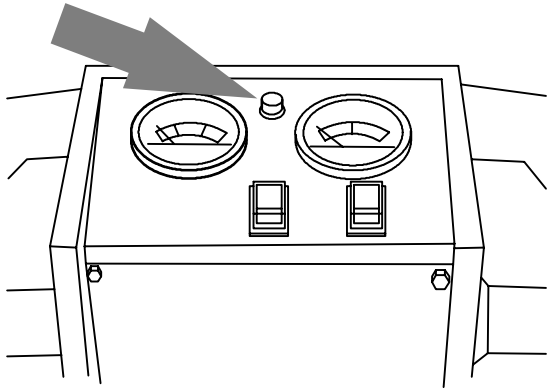

Slow: Turn the switch knob counter-clockwise .

Fast: Turn the switch knob clockwise .

## BRUSH PRESSURE GAUGE

The brush pressure gauge shows how hard the scrub brush motor is working. The brush pressure should be operated in the **green** zone. Operating in the **red** zone indicates excessive brush pressure, and will cause the scrub brush circuit breaker to trip.

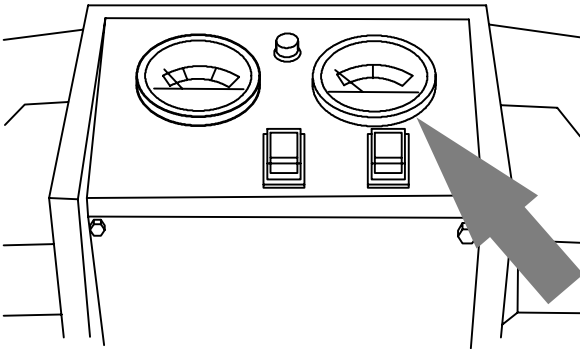

## MACHINE POWER SWITCH

The machine power switch turns on and off the machine power.

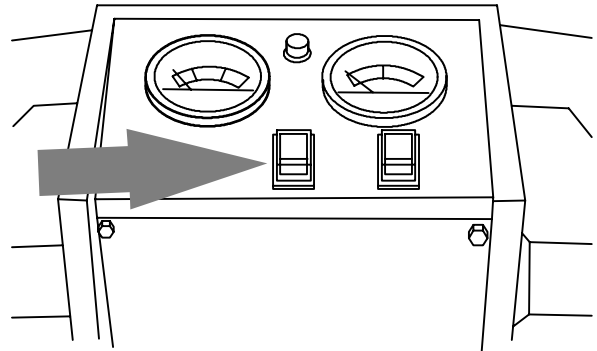

On: Press the top of the machine power switch. The switch will light up.

Off: Press the bottom of the machine power switch.

## SOLUTION SWITCH

The solution switch starts and stops the solution flow.

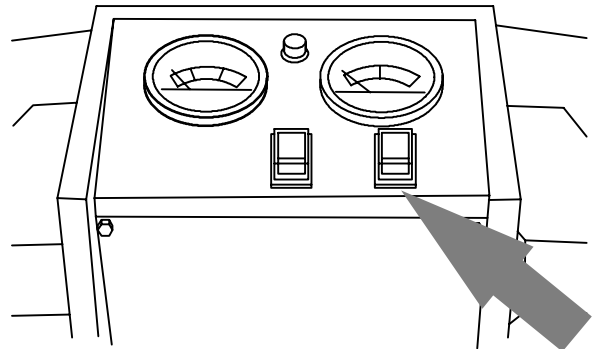

Start: Press the top of the solution switch. The switch will light up.

**NOTE:** Stop the solution flow just before turning a corner. Then start the solution flow once around the corner.

Stop: Press the bottom of the solution switch.

---

## ES (EXTENDED SCRUB) PUMP ON LIGHT (OPTION)

The pump on light will come on when the ES solution pump starts.

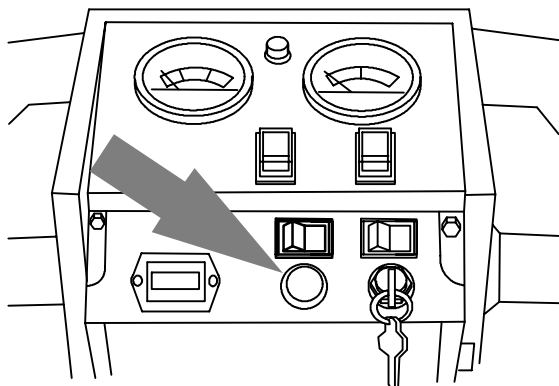

---

## ES (EXTENDED SCRUB) SWITCH (OPTION)

The ES switch turns on and off the solution recycling system.

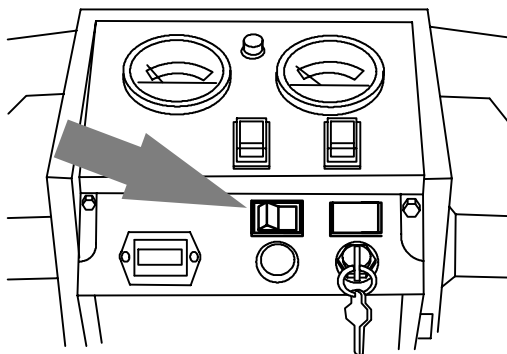

On: Press the right side of the ES switch. The switch will light up.

Off: Press the left side of the ES switch.

---

## POWER WAND SWITCH (OPTION)

The power wand switch turns on and off the power wand solution system.

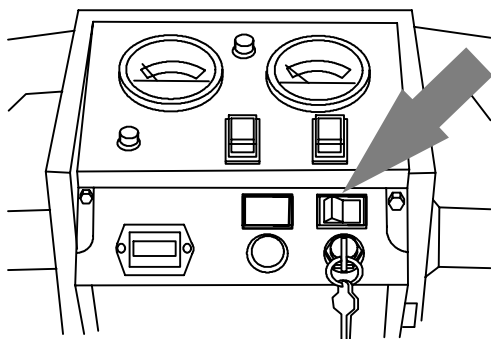

On: Press the right side of the power wand switch. The switch will light up.

Off: Press the left side of the power wand switch.

---

## HOURLY METER (OPTION)

The hour meter  records the number of hours the machine has been powered on. This information is useful when servicing the machine.

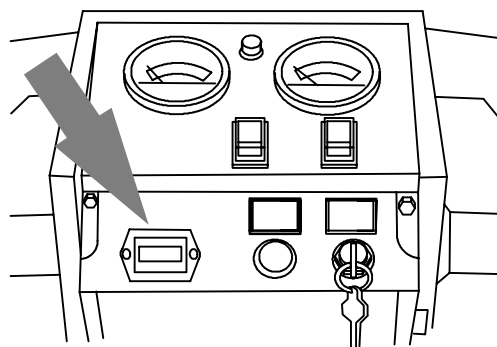

---

## ON-OFF KEY SWITCH (OPTION)

The ON-OFF key switch controls the machine power. The power on light will illuminate when the key is turned on.

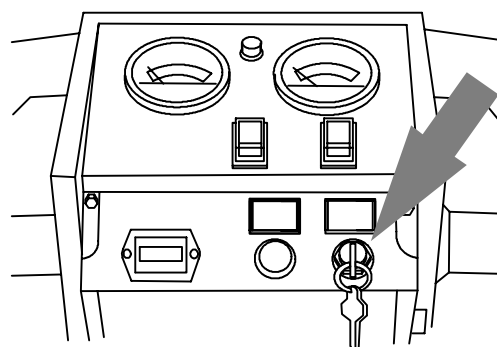

On: Turn the key to the right.

Off: Turn the key to the left.

# OPERATION

## CIRCUIT BREAKERS

The circuit breakers are resettable electrical circuit protection devices. They are designed to stop the flow of current in the event of a circuit overload. Once a circuit breaker is tripped, reset manually by pressing the reset button after the breaker has cooled down.

If the overload that caused the circuit breaker to trip is still there, the circuit breaker will continue to stop current flow until the problem is corrected.

The circuit breakers are located below the operator console.

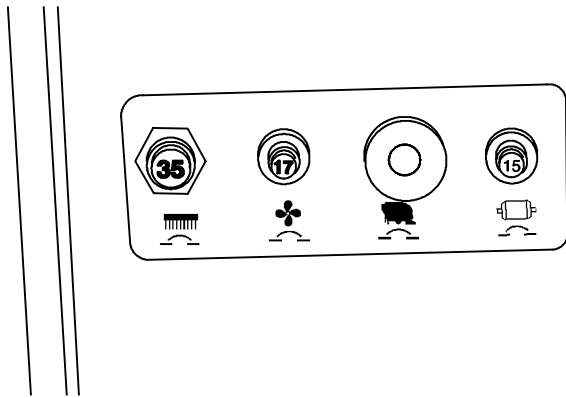

The chart shows the circuit breakers and the electrical components they protect.

Circuit Breaker	Rating	Circuit Protected
	35 A	Scrub brush
	17 A	Vacuum fan
	7 A	Machine power
	15 A	Machine propel

## FUSE

Fuses are a one-time protection device designed to stop the flow of current in the event of a circuit overload. Never substitute higher value fuses than specified.

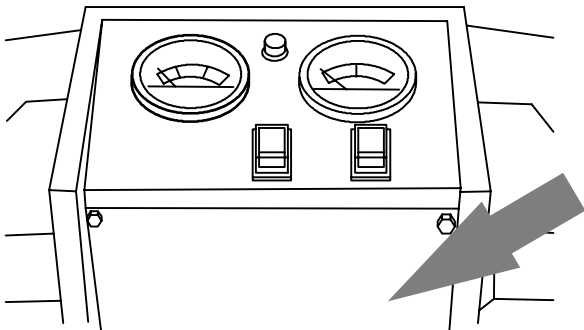

The fuse is located inside the instrument panel.

Fuse	Rating	Circuit Protected
FU-1	1 A	Directional potentiometer

## POWER KILL SWITCH (OPTION)

The power kill switch halts all power to the machine.

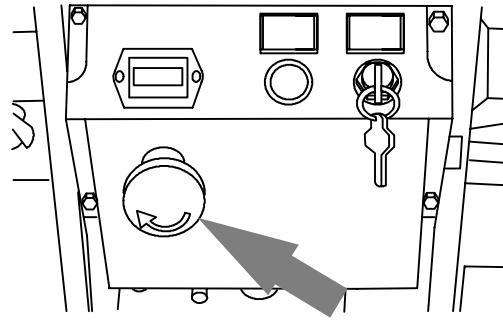

**Halt:** Hit the power kill switch.

**Restart:** Turn off the machine power. Turn the power kill switch to the right to release the switch. Turn on the machine power.

## SOLUTION FLOW KNOB

The solution flow knob controls the amount of solution flow to the floor.

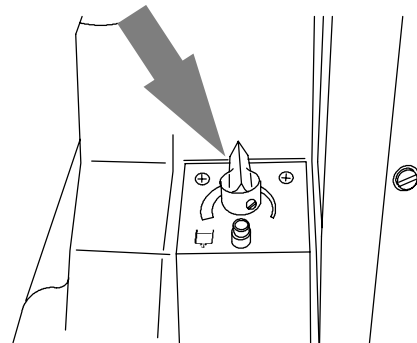

**Increase:** Turn the solution knob counter-clockwise. The more you turn the knob, the more you increase the solution flow to the floor.

**Decrease:** Turn the solution knob clockwise.

**BRUSH PRESSURE KNOB**

The brush pressure knob adjusts the amount of brush pressure to the floor. The indicator below the knob shows if the brush pressure is increasing or decreasing.

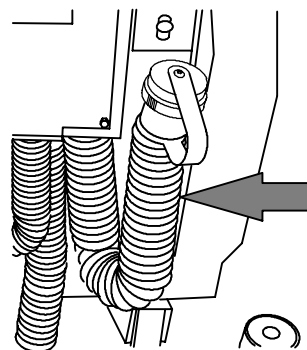
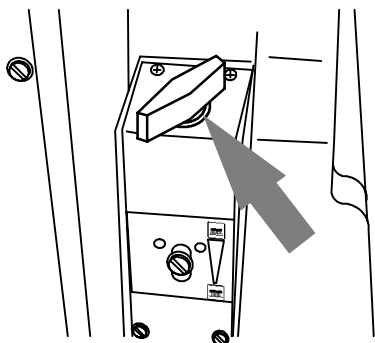

**SOLUTION TANK HOSE**

The hose is used to drain the solution tank. The drain hose plug is removed by flipping up the plug latch and pulling the plug out of the drain hose. The drain hose is plugged by placing the hose plug in the end of the hose and flipping the plug latch down.

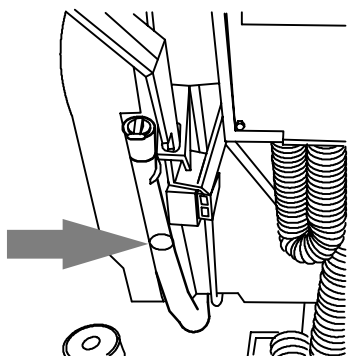

The clear solution tank hose shows the solution level in the solution tank when the hose plug is removed.

**RECOVERY TANK DRAIN HOSE**

The recovery tank drain hose is used to drain the recovery tank. The drain hose cap is removed by turning the cap counter-clockwise to loosen and pulling the cap off of the drain hose. The drain hose is plugged by placing the cap on the end of the hose and turning clockwise to tighten the cap.

**SQUEEGEE LEVER**

The squeegee lever controls the squeegee and the vacuum system.

Lower Squeegee and Start Vacuum: Move the squeegee lever to the left to unlock it, then move the lever all the way forward.

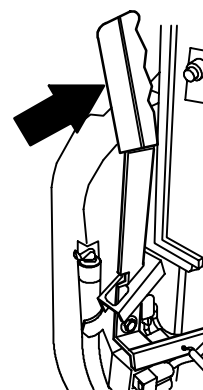

Raise Squeegee and Stop Vacuum: Pull the lever towards you, and move it to the right to lock the lever in the up position.

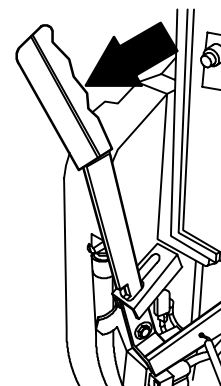

# OPERATION

---

## STOP ARM

The stop arm prevents the recovery tank from pinching fingers when the tank is lowered. Rotate the arm up to lower the recovery tank completely.

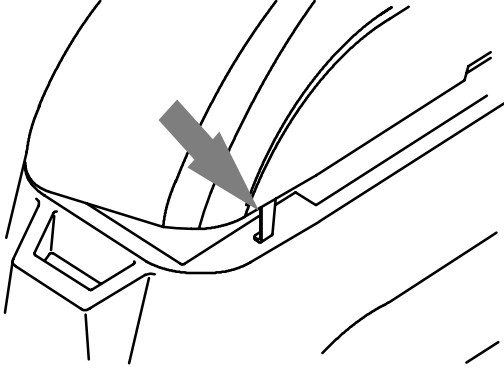

## SCRUB HEAD PEDALS

The scrub head pedals raise and lower the scrub head. The scrub brush starts when the scrub head is lowered and the steering handles are twisted forward or backward.

Lower and Start: Step on the release pedal with your foot.

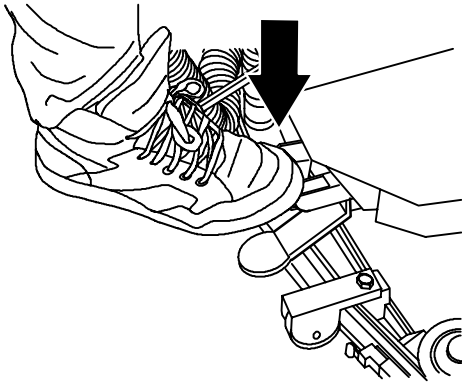

Raise and Stop: Step on the lift pedal with your foot.

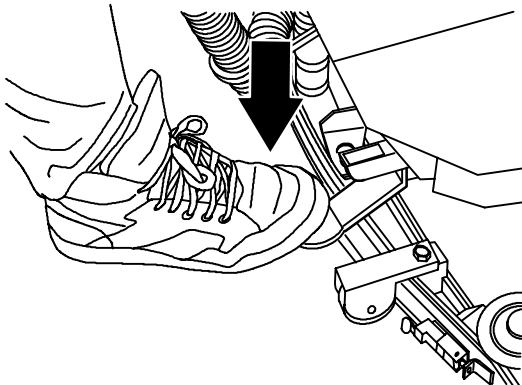

## SQUEEGEE DOWN PRESSURE KNOB

The squeegee down pressure knob adjusts the down pressure the squeegee has against the floor.

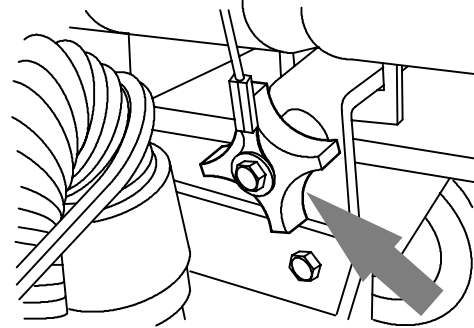

Increase: Turn the squeegee down pressure knob clockwise. Increase down pressure when scrubbing rough floor surfaces.

Decrease: Turn the squeegee down pressure knob counter-clockwise. Decrease down pressure when scrubbing smooth floor surfaces.

## SQUEEGEE LEVELING KNOB

The squeegee leveling knob adjusts the deflection at the ends of the squeegee blade.

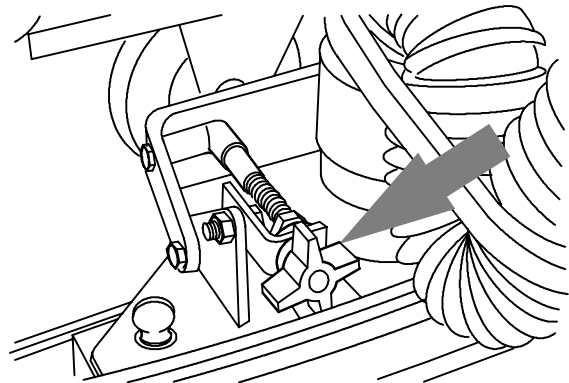

Increase: Turn the squeegee leveling knob counter-clockwise to increase the deflection at the end of the squeegee blades.

Decrease: Turn the squeegee leveling knob clockwise to decrease the deflection at the end of the squeegee blades.

To adjust the squeegee deflection along the entire width of the squeegee see ADJUSTING SQUEEGEE BLADE DEFLECTION in the Maintenance section.

## HOW THE MACHINE WORKS

The scrub components of the machine are a solution tank, a scrub brush, a squeegee, a vacuum fan, and a recovery tank.

Water and detergent from the solution tank flows to the floor through a solution valve to the scrub brush. The brush scrubs the floor. As the machine is moved forward the squeegee wipes the dirty solution off the floor, which is then picked up and drawn into the recovery tank.

The steering handles control the direction of the machine in forward or reverse. By twisting the steering handles forward, the machine propels forward. By twisting the handles towards you the machine propels backward. The speed switch controls the forward speed of the machine.

When using the ES (Extended Scrub) option, the dirty solution in the recovery tank is filtered and returned to the solution tank to be reused.

## MACHINE INSTALLATION

### INSTALLING BATTERIES

**⚠ WARNING: Fire Or Explosion Hazard. Batteries Emit Hydrogen Gas. Keep Sparks And Open Flame Away. Keep Battery Hood Open When Charging.**

**FOR SAFETY: When servicing machine, wear protective gloves and eye protection when handling batteries and battery cables. Avoid contact with battery acid.**

#### Battery Specifications:

Two 12 volt, deep cycle, 130 Amp hour batteries standard. Two 12 volt, deep cycle, 215 Amp hour batteries optional. Maximum battery dimensions are 178 mm (7 in) W x 381 mm (15 in) L x 372 mm (14.63 in) H.

1. Hinge open recovery tank to access battery compartment.

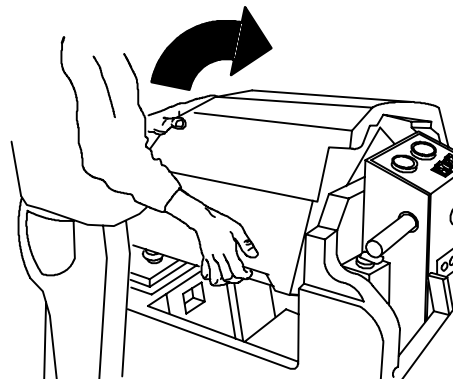

2. Carefully install batteries into battery compartment tray with battery posts positioned as shown. Secure batteries with battery spacers.

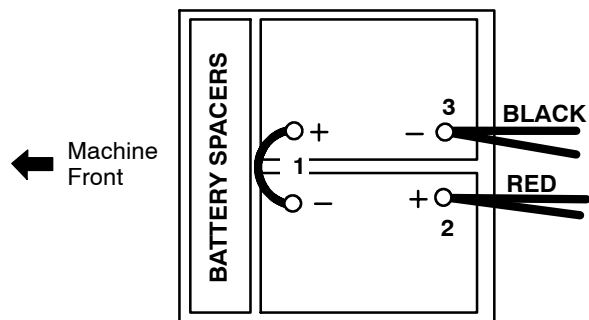

**ATTENTION: Do not drop the batteries into the compartment, battery and machine housing damage may result.**

3. Before connecting the battery cables, make sure the terminals and posts are clean. Use a post cleaner and wire brush if necessary.

**NOTE: Apply a light coating of non-metallic grease or protective spray on the cable connections to prevent battery corrosion.**

4. Connect cables to battery posts in numerical order as labeled, RED TO POSITIVE & BLACK TO NEGATIVE, use battery post covers and rubber boots supplied.
5. Check battery discharge indicator. Machine must be in full operation for accurate reading (See MACHINE OPERATION). Charge batteries if necessary.

# OPERATION

## PRE-OPERATION CHECKLIST

Check over this list of items before operating the machine:

- Check under the machine for leaks.

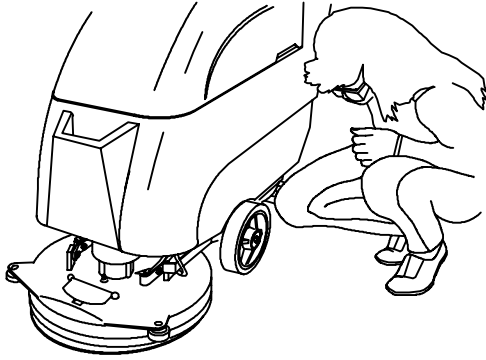

- Check and make sure the scrub head skirt touches the floor all the way around the scrub head.

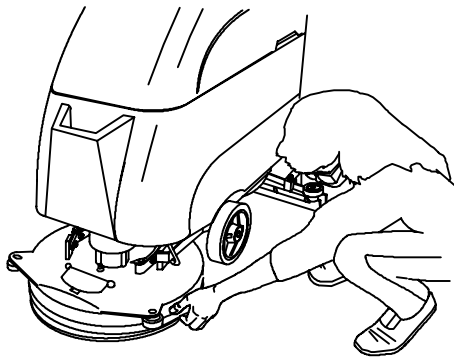

- Check the squeegee for proper deflection. Check the squeegee blade for wear, rounded edges, nicks, or cuts.

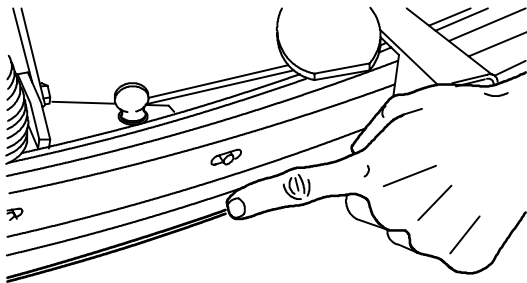

## STARTING THE MACHINE

Turn the machine power on.

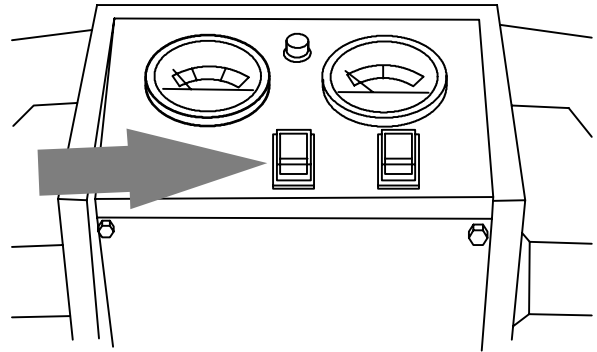

## FILLING THE TANKS

1. Start the machine.
2. Drive the machine to the filling site.

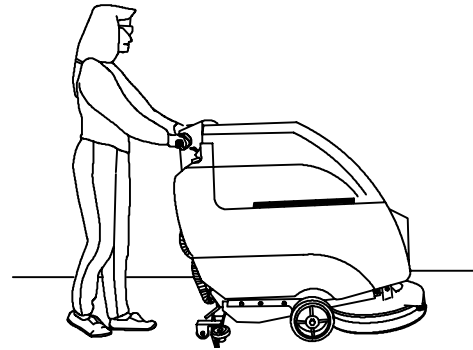

**FOR SAFETY: Before leaving or servicing machine, stop on level surface and turn off machine.**

3. Turn the machine power off.

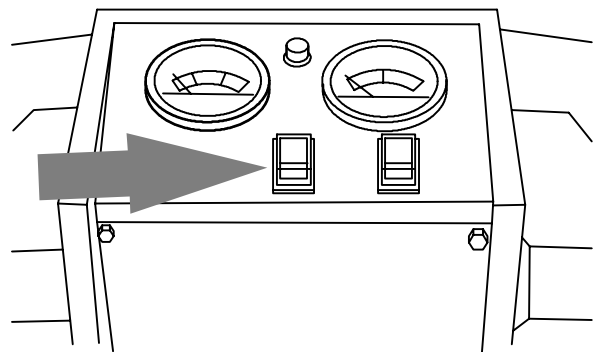

**FOR SAFETY: Before leaving or servicing machine, stop on level surface and turn off machine.**

- Remove the fill-port cover at the front of the machine and fill solution tank to the opening screen with clean water, 60°C (140°F) maximum. Add cleaning chemical. See proper dilution ratio instructions on bottle. Solution tank capacity is 45L (12 gal.).

**NOTE:** The water must **not** be hotter than 60°C (140°F) or tank damage may occur.

**NOTE:** If filling with a bucket be certain that bucket is clean. This will prevent possible solution line clogs.

**FOR SAFETY: When using machine, follow mixing and handling instructions on chemical containers.**

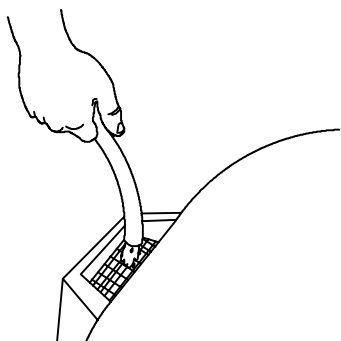

**ATTENTION: Use only recommended detergents. Machine damage due to improper detergent usage will void the manufacturer's warranty. Contact your Tennant Sales Representative for detergent recommendations.**

**NOTE:** Floor conditions, water condition, amount of soil, type of soil, brush action all play an important role in determining the type and concentration of detergent used. For specific recommendations, contact your TENNANT representative.

**⚠ WARNING: Fire Or Explosion Hazard. Never Use Flammable Liquids.**

- ES Mode Option: Open the recovery tank cover and fill the recovery tank with no more than 23L (6 gal) of water.

**NOTE:** When using the ES Option, make sure to activate the ES Option ON/OFF switch.

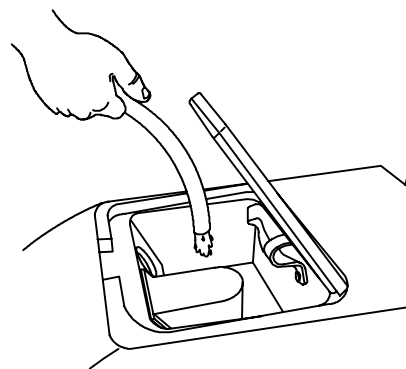

## NORMAL SCRUBBING AND ES (EXTENDED SCRUB) SCRUBBING

- Pick up oversized debris before scrubbing. Pick up pieces of wire, string, twine, etc., which could become wrapped around the scrub brush.



- Plan the scrubbing in advance. Try to arrange long runs with minimum stopping and starting. Do an entire floor or section at one time.
- Try to scrub as straight a path as possible. Avoid bumping into posts or scraping the sides of the machine. When scrubbing dead end aisles, start at the closed end of the aisle and scrub your way out. Overlap the scrub paths by a few centimeters (inches).
- When you see poor scrubbing performance, stop scrubbing and refer to *TROUBLESHOOTING*.

# OPERATION

1. Start the machine.
2. Drive the machine to the area to be scrubbed .

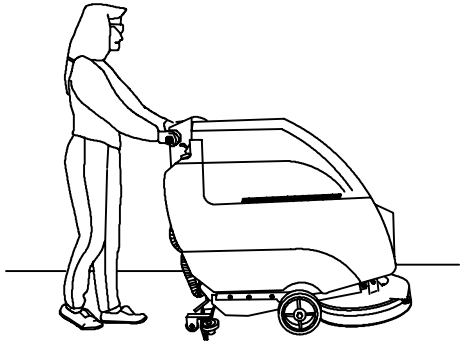

3. ES SCRUBBING: Press the right side of the ES switch to activate the ES system. The switch will light up.

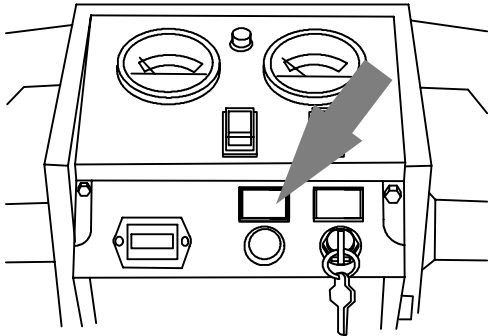

4. Lower the squeegee to the floor with the squeegee lever.

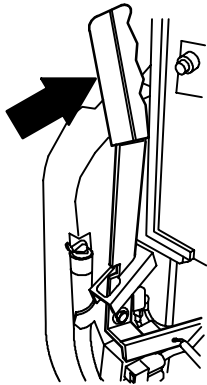

5. Start the solution flow with the solution switch.

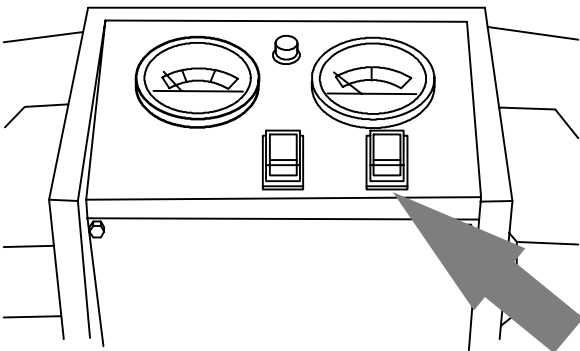

6. Lower the scrub brush with the scrub head release pedal.

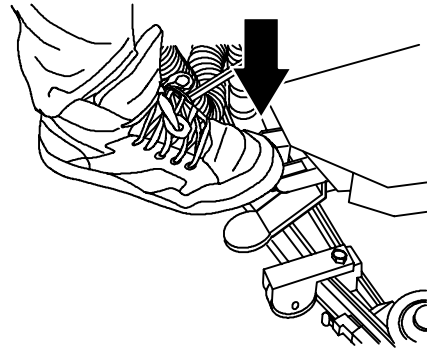

7. Drive the machine forward and scrub as required.

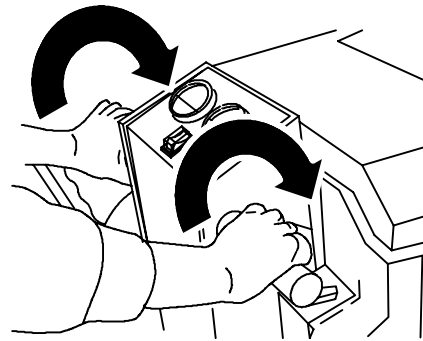

**⚠ WARNING: Fire Or Explosion Hazard. Do Not Pick Up Flammable Materials Or Reactive Metals.**

8. Adjust the solution flow to the floor as needed.

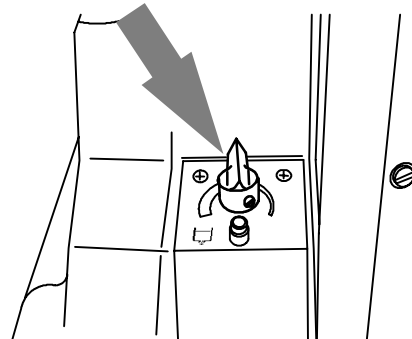

9. Adjust brush pressure for cleaning application.

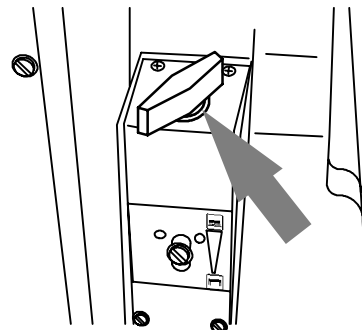

## DOUBLE SCRUBBING

Double scrubbing is a method for removing heavy floor accumulations. This is done by making two passes over the area to be cleaned with the machine.

First, make a pass over the area scrubbing with the squeegee up. This dispenses solution over the area allowing the solution to soak on the floor. Let the solution remain on the floor for 3 to 5 minutes. Then make a second pass scrubbing with the squeegee down.

**FOR SAFETY: When using machine, go slow on inclines and slippery surfaces.**

## STOP SCRUBBING

1. Release the steering handles.

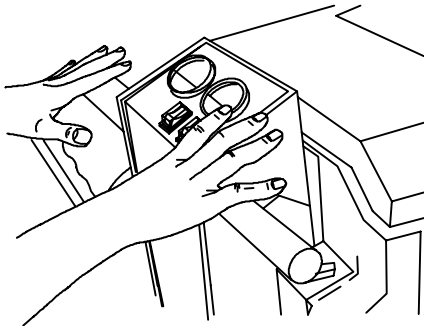

2. Raise the scrub brush with the scrub head lift pedal.

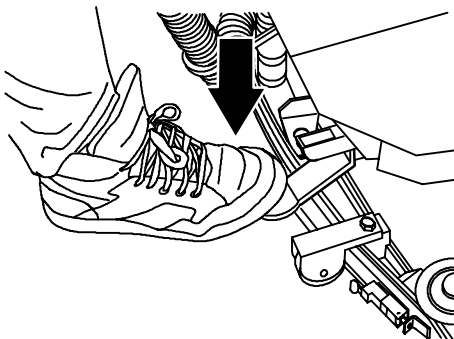

3. Turn the solution switch off. Propel the machine forward to pick up any solution left on the floor.

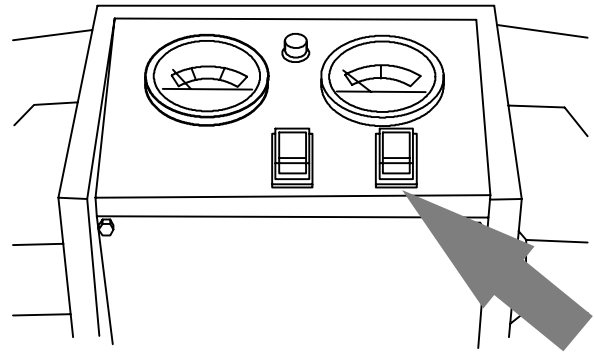

4. Raise the squeegee with the squeegee lever.

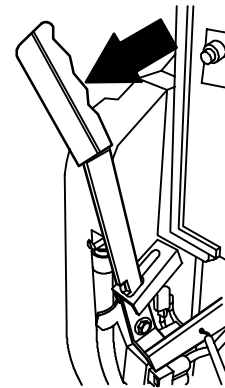

## DRAINING AND CLEANING THE TANKS

The recovery tank must be drained and cleaned out after every use.

The solution tank should be cleaned out periodically to remove any corrosion. When using the ES option, the solution tank must be drained and cleaned out after every use.

1. Stop scrubbing.
2. Drive the machine next to a floor drain or sink.

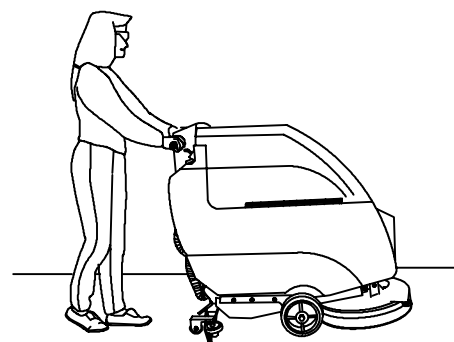

# OPERATION

3. Turn the machine power off.

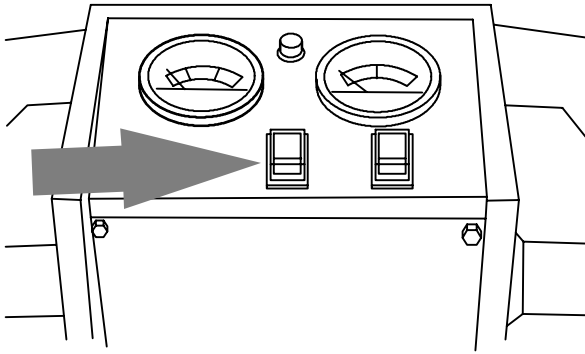

**FOR SAFETY: Before leaving or servicing machine, stop on level surface and turn off machine.**

4. Remove the recovery tank drain hose from the mounting clip.

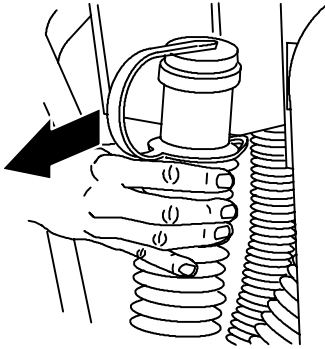

5. Remove the drain hose cap while holding the hose up, then slowly lower the drain hose to the floor drain or sink.

**NOTE: If using a bucket to drain machine, do not use same bucket for filling solution tank. This will prevent possible solution line clogs.**

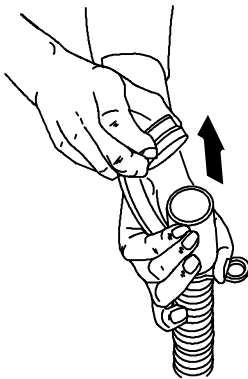

6. Open the recovery tank cover.

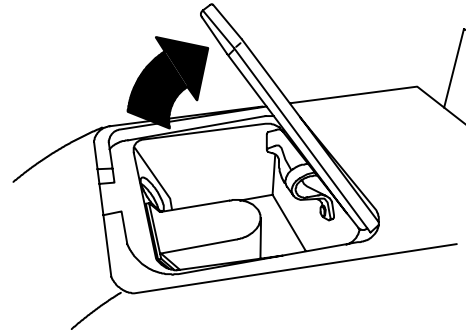

7. Flush out the inside of the recovery tank with clean water.

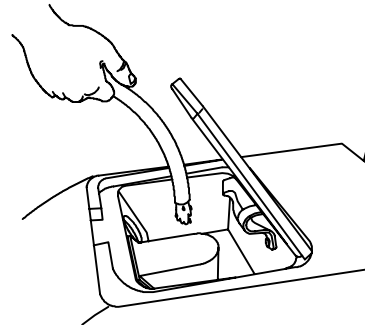

**NOTE: The water must *not* be hotter than 60°C (140°F) or tank damage may occur. Do not use steam to clean the tank.**

8. Rinse the float screen. Remove and clean the screen if it is still dirty. Put the screen back in the tank.

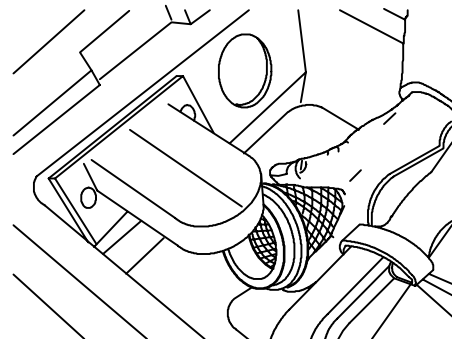

9. ES option: Rinse the ES filter. Remove and clean the filter if it is still dirty. Put the filter back in the tank.

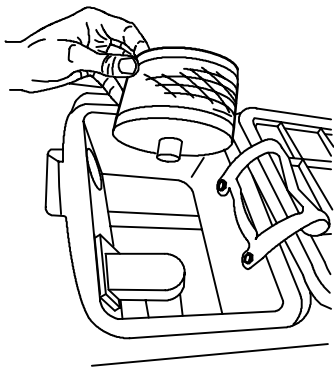

10. When the tank has completely drained, replace the drain hose cap on the recovery tank drain hose.

**NOTE:** If using a bucket to drain machine, do not use same bucket for filling solution tank. This will prevent possible solution line clogs.

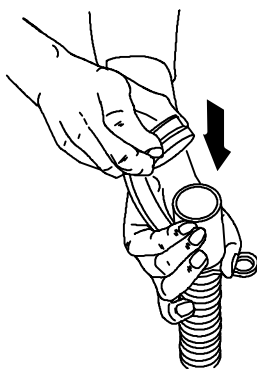

11. Place the recovery tank drain hose back onto the mounting clip on the machine.

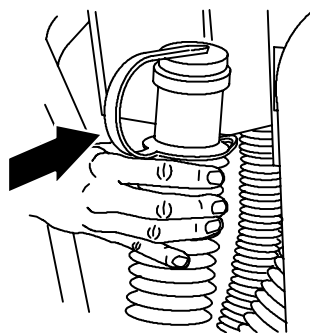

12. ES option: Remove the solution tank drain hose from the mounting clip.

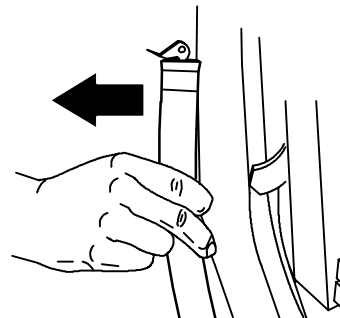

13. ES option: Remove the drain hose plug while holding the hose up, then slowly lower the drain hose to the floor drain.

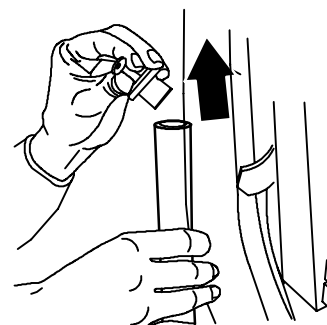

14. ES option: Lift the recovery tank to reach the solution tank. Lift the solution tank cover and flush out the solution tank with clean water. Rinse the filter at the bottom of the solution tank.

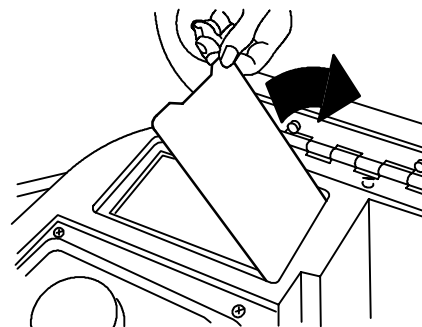

**NOTE:** The water must **not** be hotter than 60°C (140°F) or tank damage may occur. **Do not** use steam to clean the tank.

**NOTE:** If using a bucket to drain machine, do not use same bucket for filling solution tank. This will prevent possible solution line clogs.

# OPERATION

- ES mode: When the solution tank has completely drained, replace the drain hose plug in the solution tank drain hose.

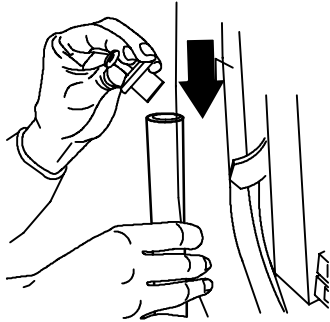

- ES mode: Place the solution tank drain hose back into the mounting clip.

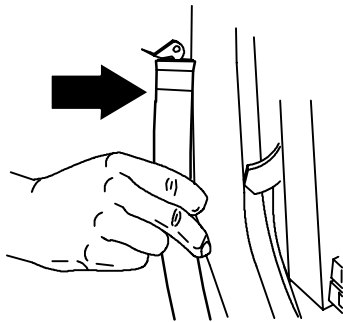

- Close the solution tank cover, and lower the recovery tank. Rotate the stop arm out of the way to allow the recovery tank to close completely.

## STOP THE MACHINE

- Stop scrubbing.
- Turn the machine power off.

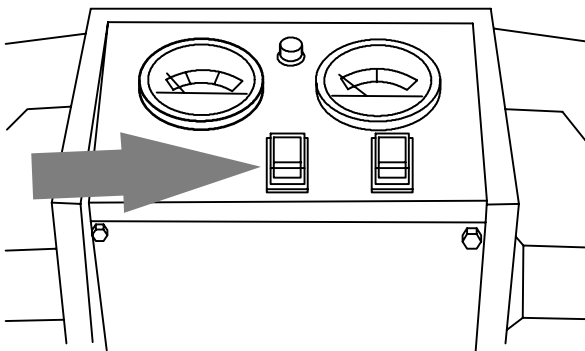

**FOR SAFETY: Before leaving or servicing machine, stop on level surface and turn off machine.**

## OPERATING ON INCLINES

Drive the machine slowly on inclines.

**FOR SAFETY: When using machine, go slow on inclines and slippery surfaces.**

The maximum rated climb and descent incline with empty tanks is 8°, with full tanks is 6°.

## POST-OPERATION CHECKLIST

Check over this list of items after you have finished scrubbing with the machine with the machine powered on:

- Check the battery charge level.

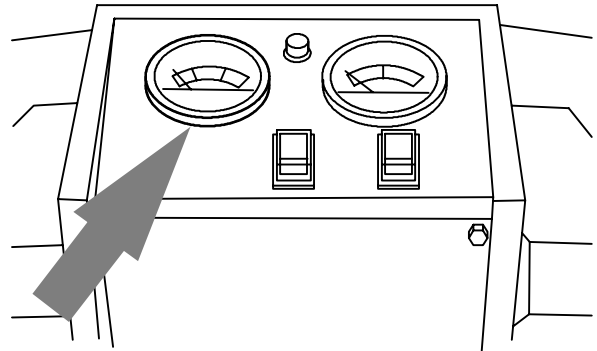

**NOTE: The reading on the battery discharge indicator is not accurate when the machine is first powered on. Operate the machine a few minutes before reading the charge level of the batteries.**

Check over this list of items with machine powered off:

- Check for wire, string, or twine wrapped around the scrub brush.
- Check the squeegee for wear or damage.

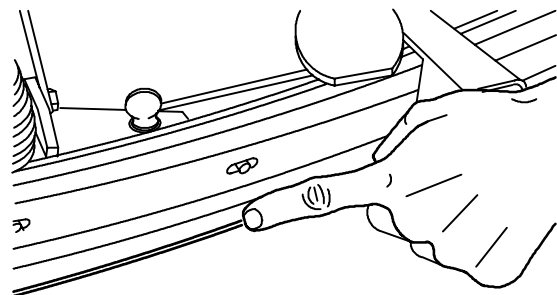

- Drain and clean the recovery tank.

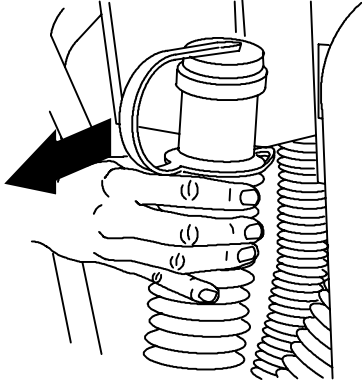

- ES machines: Drain and clean the solution tank.
- Check the vacuum hoses for obstructions.
- Check for any machine leaks.

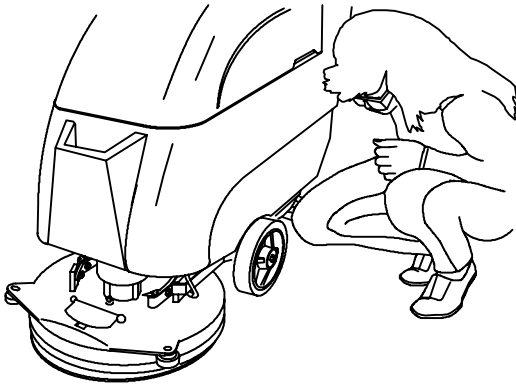

- Check the service records to determine service requirements.

## CHARGING BATTERIES

**ATTENTION:** To prolong the life of the batteries and to provide optimum machine performance, **ONLY** recharge the batteries after a total of 30 minutes of use or more. Do not leave batteries discharged for lengthy periods.

The following charging instructions are intended for battery chargers supplied with the machine. Only use a battery charger with the following specifications to prevent battery damage.

### CHARGER SPECIFICATIONS:

- CHARGER TYPE: FOR LEAD ACID BATTERIES
- OUTPUT VOLTAGE - 24 VOLTS
- OUTPUT CURRENT - 12 AMPS for 130 AH Batteries
- OUTPUT CURRENT - 20 AMPS for 215 AH Batteries
- AUTOMATIC SHUTOFF CIRCUIT
- FOR DEEP CYCLE BATTERY CHARGING

1. Transport machine to a well ventilated area for charging.

**⚠ WARNING: Fire Or Explosion Hazard. Batteries Emit Hydrogen Gas. Keep Sparks And Open Flame Away. Keep Battery Compartment Open When Charging.**

2. Before charging the batteries, check the electrolyte level in each battery cell.

**FOR SAFETY: When servicing machine, wear protective gloves and eye protection when handling batteries or battery cables. Avoid contact with battery acid.**

The electrolyte level (A) should slightly cover the battery plates (B). Add distilled water as needed. **DO NOT OVERFILL**, the fluid may expand and overflow while charging. Replace cell caps before charging.

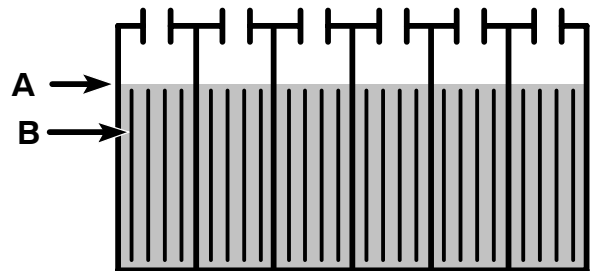

3. Connect the charger's AC power supply cord to a properly grounded receptacle.

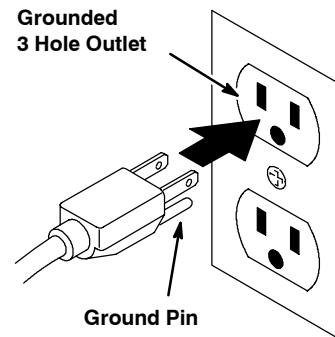

4. With charger's power supply cord unplugged, connect battery charger to machine.

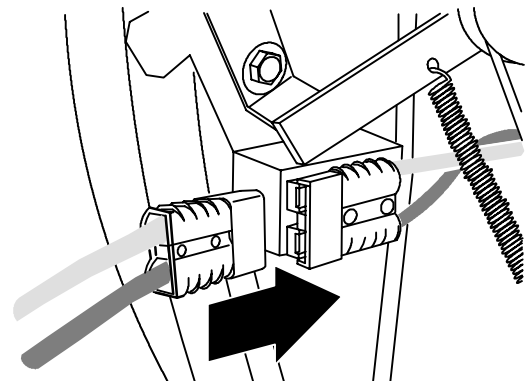

# OPERATION

5. The charger will automatically begin charging and shut off when fully charged.
6. Rest the recovery tank on the support stand to promote ventilation during charging.

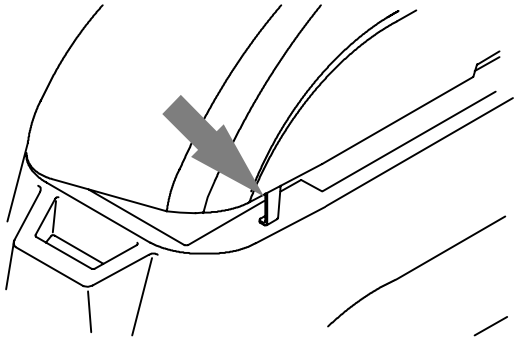

**ATTENTION: Do not disconnect the charger's DC cord from the machine's receptacle when the charger is operating. Arcing may result. If the charger must be interrupted during charging, disconnect the AC power supply cord first.**

**⚠ WARNING: Fire Or Explosion Hazard. Batteries Emit Hydrogen Gas. Keep Sparks And Open Flame Away. Keep Battery Compartment Open When Charging.**

7. After charging, check the electrolyte level (A) again. The level should be approximately 1 cm from the bottom of the fill-port (B). Add distilled water if needed. **DO NOT OVERFILL.**

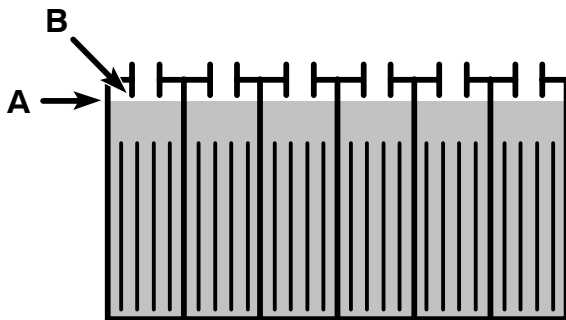

# OPTIONS

## VACUUM WAND

The vacuum wand uses the machine's vacuum system. The vacuum hose allows pick-up of spills that are out of reach of the machine.

1. Turn the machine power off.

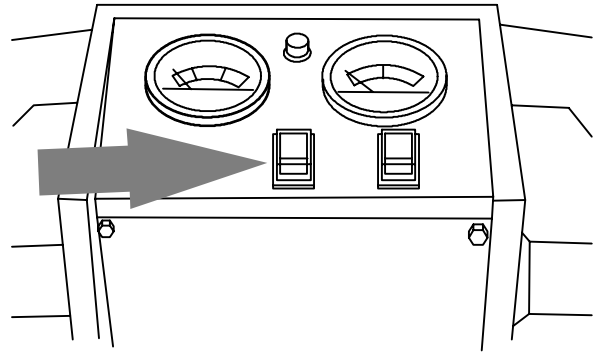

**FOR SAFETY: Before leaving or servicing machine, stop on level surface and turn off machine.**

2. Remove the squeegee suction hose from the top of the squeegee.

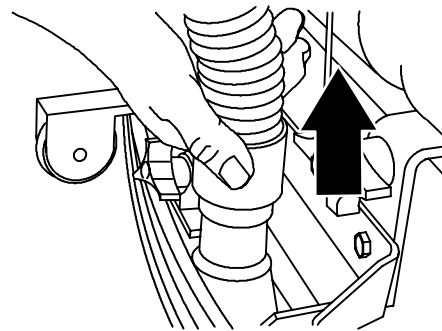

3. Put together the wand and the wand hose.
4. Connect the vacuum wand hose and the squeegee suction hose with the adapter.

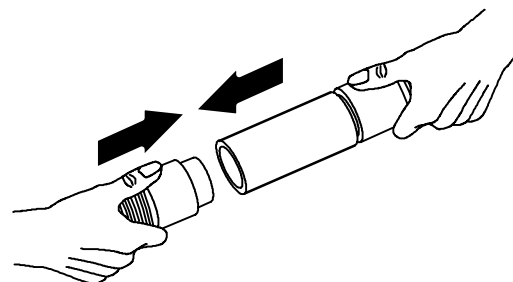

5. Turn the machine power on.

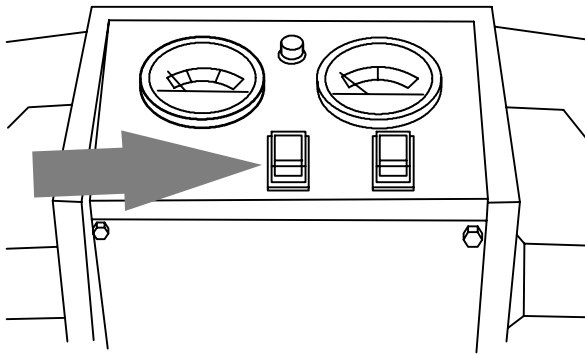

9. Turn the machine power off.

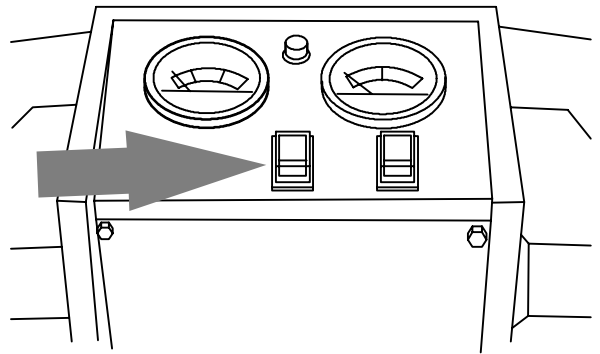

6. Lower the squeegee with the squeegee lever to turn the vacuum system on.

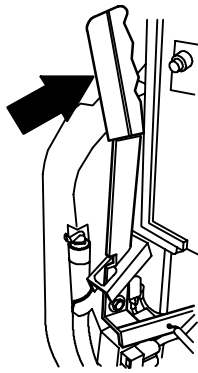

10. Remove the vacuum hose from the squeegee suction hose.

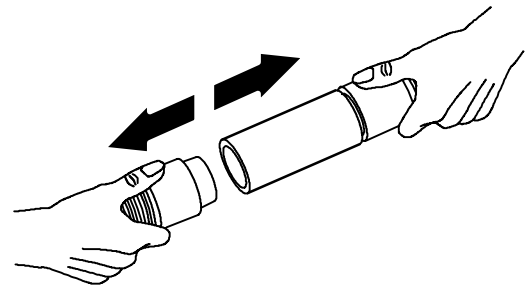

7. Vacuum the floor.



11. Reconnect the squeegee suction hose to the top of the squeegee.

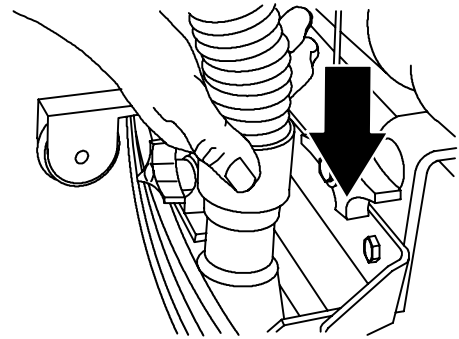

8. When finished, raise the squeegee to shut off the vacuum.

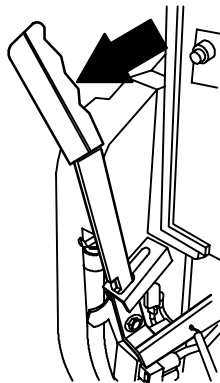

# OPERATION

## POWER WAND

The power wand uses the machine's vacuum and solution systems. The power wand allows scrubbing of floors that are out of reach of the machine.

1. Turn the machine power off.

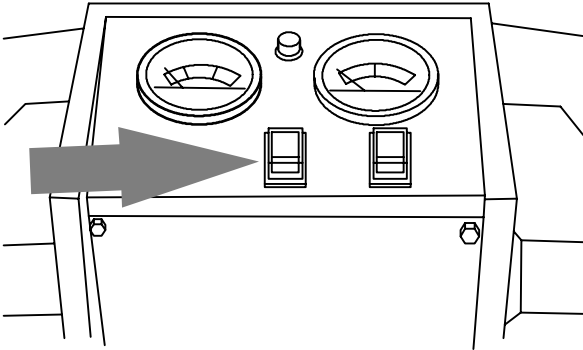

**FOR SAFETY: Before leaving or servicing machine, stop on level surface and turn off machine.**

2. Remove the squeegee suction hose from the top of the squeegee.

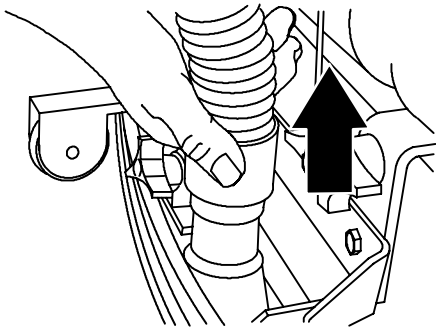

3. Connect the vacuum wand hose and the squeegee suction hose with the adapter.

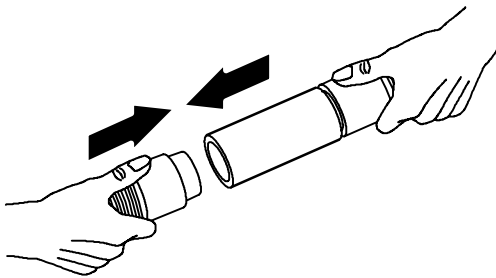

4. Attach the end of solution hose to the quick-disconnect. Push the connector in until it stops. Pull on the hose to make sure it is connected.

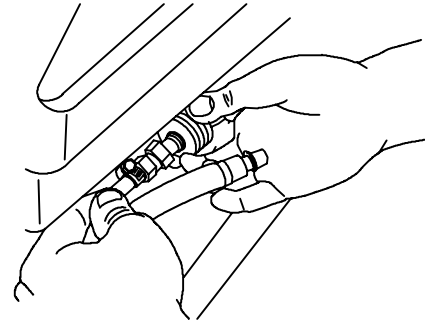

5. Attach the other ends of the solution and vacuum hoses to the power wand.

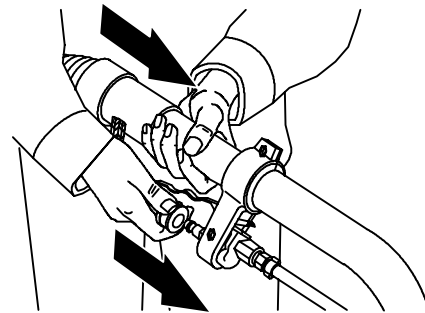

6. Turn the machine power on.

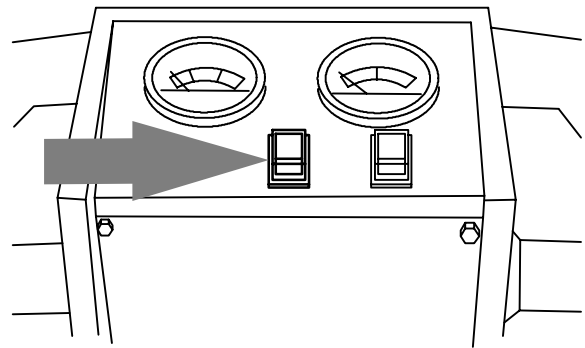

7. Lower the squeegee with the squeegee lever to turn the vacuum system on.

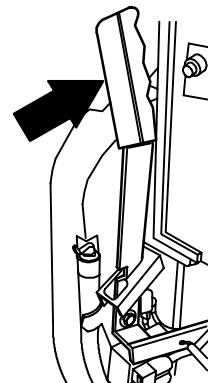

8. Switch the power wand switch on.

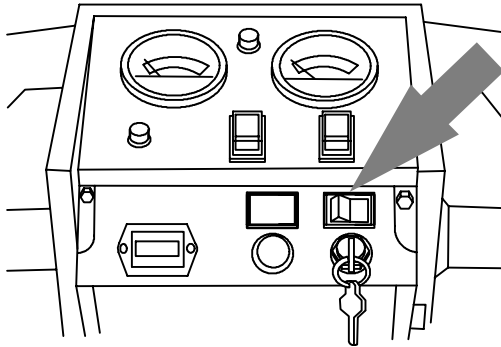

9. Squeeze the solution lever on the power wand to spray solution on the floor. Scrub the floor with the brush side of the cleaning tool.

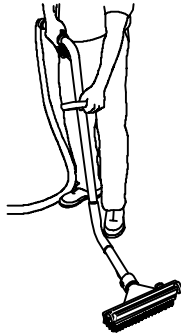

10. Vacuum up the solution by turning over the cleaning tool so the squeegee side is down.

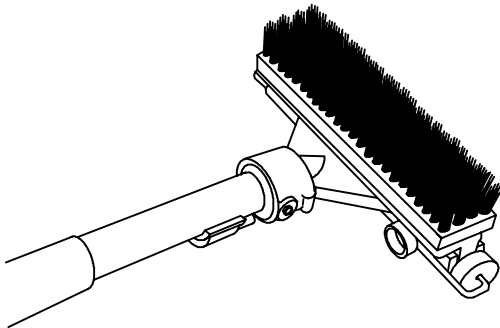

If the cleaning tool is hard to push, or is not picking up the solution very well, adjust the roller wheels on the tool by turning the black adjustment knob.

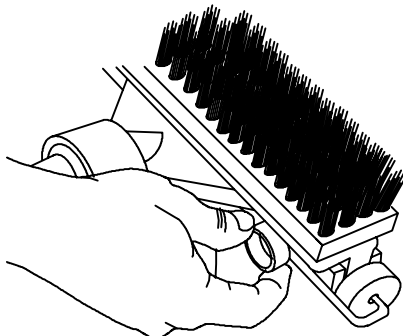

**NOTE:** The wheels are properly adjusted when the squeegee blades deflect slightly while the tool is pushed back and forth.

11. When finished, switch the power wand off.

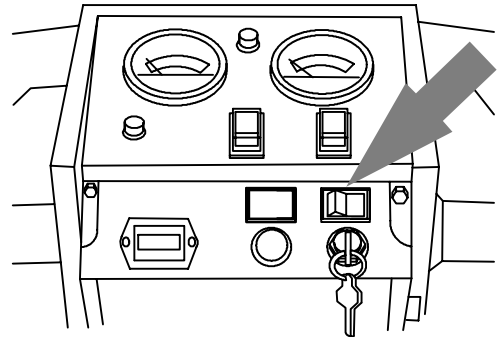

12. When finished, raise the squeegee to shut off the vacuum.

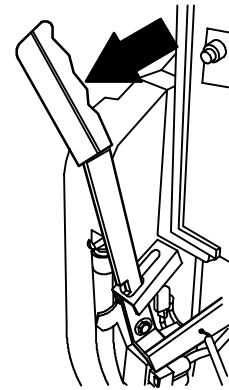

13. Disconnect the solution hose from the machine.

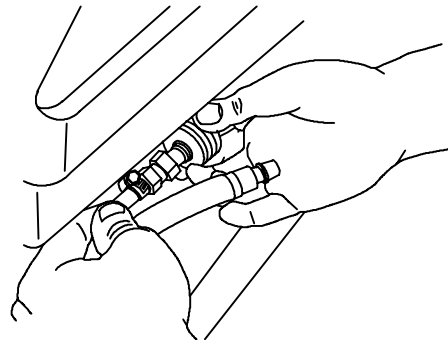

14. Remove the vacuum hose from the squeegee suction hose.

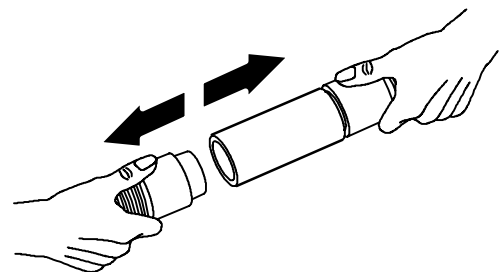

# OPERATION

---

15. Disconnect the other ends of the solution and vacuum hoses from the power wand.

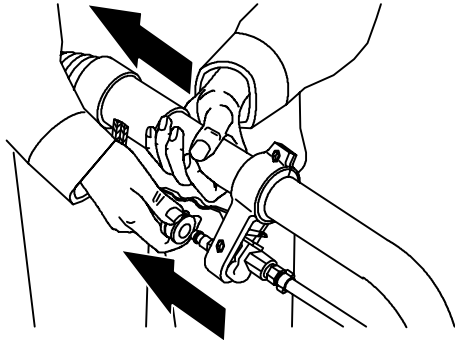

16. Turn the machine power off.

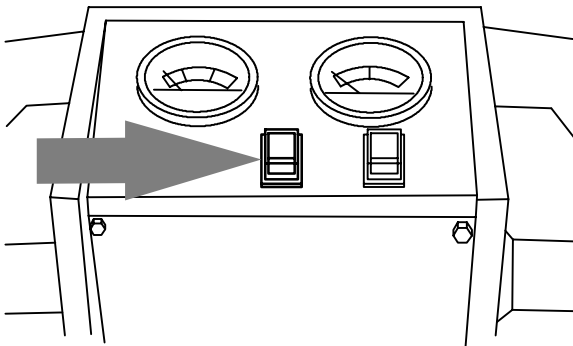

17. Reconnect the squeegee suction hose to the squeegee.

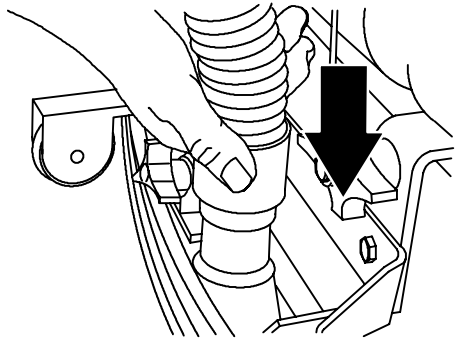

---

## MACHINE MAINTENANCE

---

To keep the machine in good working condition, simply follow the daily, monthly and quarterly maintenance procedures.

**⚠ WARNING: Electrical Hazard. Disconnect Battery Cables Before Servicing Machine.**

---

### DAILY MAINTENANCE (After Every Use)

1. Drain and rinse tanks thoroughly.
2. Remove and rinse off the float shut-off screen located in recovery tank.

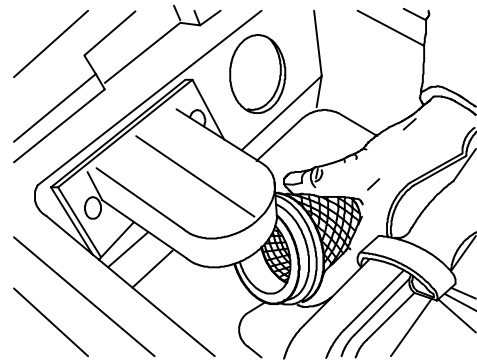

3. If equipped with ES option, remove ES filter from recovery tank and clean.

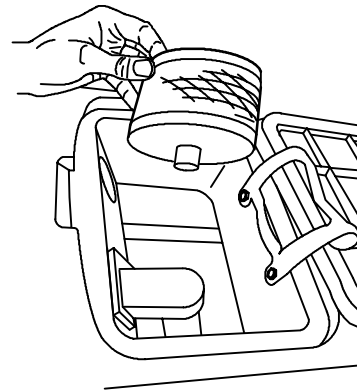

4. Remove and clean pads or brushes. Never use soiled pads when cleaning. Replace pads when they become loaded with residue. Replace brush if needed (See REPLACING THE SCRUB BRUSH).

5. Check scrub head skirt for wear. Adjust or replace as needed (See ADJUSTING THE SCRUB HEAD SKIRT or REPLACING THE SCRUB HEAD SKIRT).

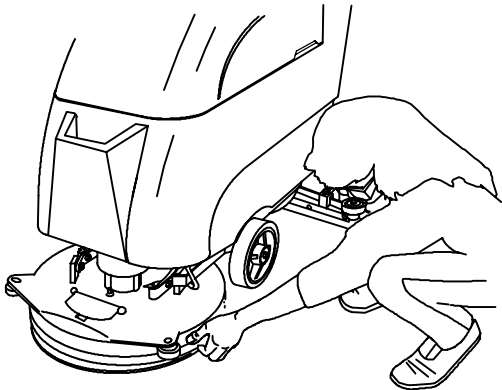

6. Raise squeegee and wipe it down with a dry cloth. Store squeegee in the up position to prevent squeegee damage.
7. Clean the machine with an all purpose cleaner and damp cloth.

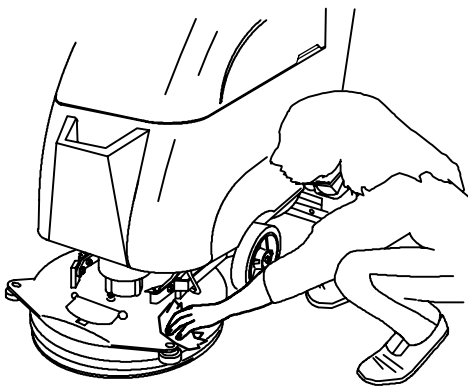

**ATTENTION:** When cleaning machine, do not power spray or hose off machine. Electrical malfunction may occur.

8. Recharge the batteries after a total of 30 minutes of use or more (See CHARGING BATTERIES).

---

## MONTHLY MAINTENANCE (Every 80 Hours of Use)

1. Check water level in battery cells (See BATTERY MAINTENANCE).
2. Clean the batteries and terminals to prevent corrosion (See BATTERY MAINTENANCE).
3. Check for loose battery cable connections.
4. Lubricate caster grease fitting with a water resistant grease.

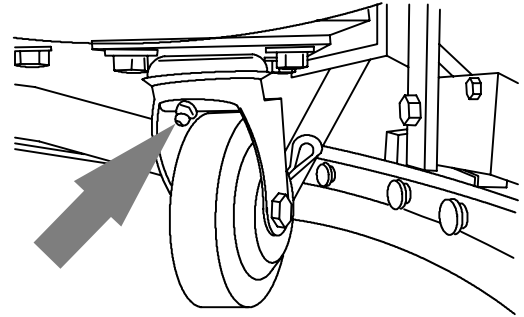

5. Lubricate all pivot points and rollers with silicone spray then coat with a water resistant grease to maintain smooth operation.
6. Check the machine for loose nuts and bolts.
7. Check the machine for leaks.

---

## QUARTERLY MAINTENANCE (Every 250 Hours of Use)

Check the drive transaxle motor, the vacuum motor and the brush motor for carbon brush wear. Replace carbon brushes when worn to a length of 10 mm or less.

**Contact an Authorized Service Center for machine repairs.**

**⚠ WARNING: Electrical Hazard. Disconnect Battery Cables Before Servicing Machine.**

---

## BATTERY MAINTENANCE

**⚠ WARNING: Fire Or Explosion Hazard. Batteries Emit Hydrogen Gas. Keep Sparks And Open Flame Away. Keep Battery Compartment Open When Charging.**

**FOR SAFETY: When servicing machine, wear protective gloves and eye protection when handling batteries and battery cables. Avoid contact with battery acid.**

1. Check the specific gravity using a hydrometer to determine the charge level and the condition of the batteries. If one or more of the battery cells read lower than the other battery cells (0.050 or more), the cell is damaged, shorted, or is about to fail. Check the hydrometer readings against the following chart to determine the remaining battery charge level.

# OPERATION

**NOTE:** Do not take readings immediately after adding distilled water. If the water and acid are not thoroughly mixed, the readings may not be accurate.



SPECIFIC GRAVITY at 27°C (80°F)	BATTERY CHARGE
1.265	100% CHARGED
1.223	75% CHARGED
1.185	50% CHARGED
1.148	25% CHARGED
1.110	DISCHARGED

**NOTE:** If the readings are taken when the battery electrolyte is any temperature other than 27°C (80°F), the reading must be temperature corrected. Add or subtract to the specific gravity reading 0.004, 4 points, for each 6°C (43°F) above or below 27°C (80°F).

- Always follow proper charging instructions (See CHARGING BATTERIES).
- Check the electrolyte level (A) in each battery cell **after charging batteries**. The level should be approximately 1 cm from the bottom of the fill-port (B). Add distilled water if needed. **DO NOT OVERFILL.**

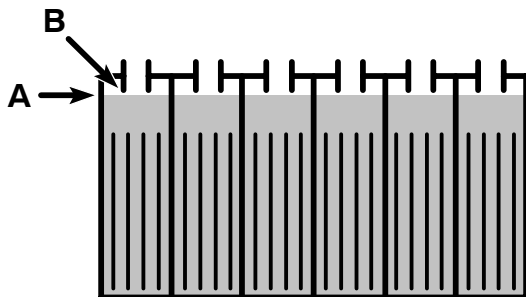

- Keep the battery tops clean to prevent battery corrosion.  
To clean batteries:

**FOR SAFETY:** When servicing machine, wear protective gloves and eye protection when handling batteries and battery cables. Avoid contact with battery acid.

- Mix a strong solution of baking soda and water.



FIG. 6

- Brush the solution sparingly over the battery tops and cable connectors.

**NOTE:** Do not allow baking soda solution to enter battery cells.

- Use a wire brush to clean the battery terminals and cable connectors.
  - After cleaning, apply a coating of clear battery post protectant to the terminals and cable connectors.
- Check for loose or worn cables. Replace if worn.

## SCRUB HEAD

The scrub head encloses the scrub brush and a solution dispensing system. The scrub head skirt controls over-spray from the scrub brush. Make sure the scrub head skirt touches the floor all the way around when the scrub head is lowered.

Check the skirt for damage or wear daily.

## ADJUSTING THE SCRUB HEAD SKIRT

- Turn the machine power off.

**FOR SAFETY:** Before leaving or servicing machine, stop on level surface and turn off machine.

- Lower the scrub head.
- Check to see if the scrub head skirt touches the floor all the way around the scrub head.

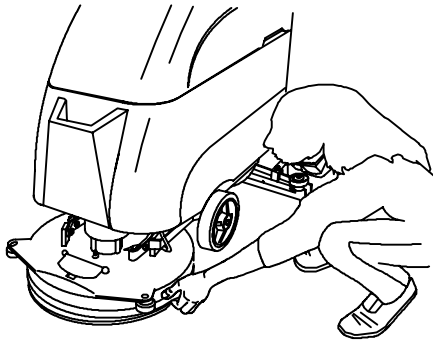

4. If the skirt needs to be adjusted, loosen the skirt band clamp and move the skirt up or down to touch the floor.

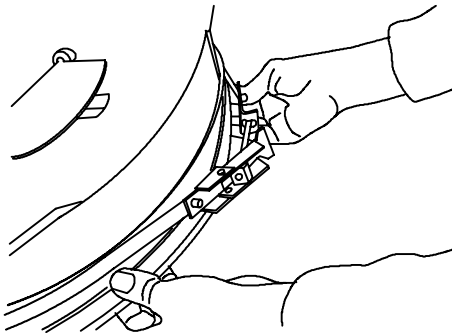

**NOTE:** Replace the scrub head skirt when it is damaged or no longer is able to touch the floor.

5. Tighten the skirt band clamp.
6. Raise the scrub head.

## REPLACING THE SCRUB HEAD SKIRT

1. Turn the machine power off.

**FOR SAFETY: Before leaving or servicing machine, stop on level surface and turn off machine.**

2. Raise the scrub head.
3. Loosen the skirt band clamp.

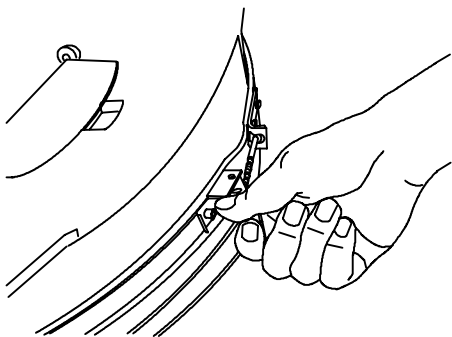

4. Pull the old skirt and band off the scrub head.

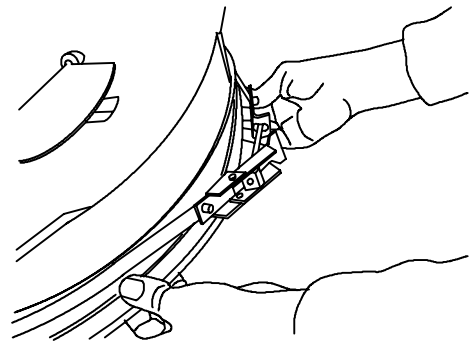

5. Put the new skirt on the scrub head. **Make sure** the holes in the skirt are facing the rear of the machine.
6. Place the skirt band over the new skirt and tighten the skirt band clamp.
7. Adjust the skirt as stated in *ADJUSTING THE SCRUB HEAD SKIRT*.

## REPLACING THE SCRUB BRUSH

The scrub brush should be replaced if large amounts of bristles are missing, or if the remaining bristles' length is less than 10 mm (0.38 in).

1. Turn the machine power off.

**FOR SAFETY: Before leaving or servicing machine, stop on level surface and turn off machine.**

2. Raise the scrub head with the scrub head lever.
3. Open the access cover on the front of the scrub head.
4. Turn the brush until you can see the brush drive pin.

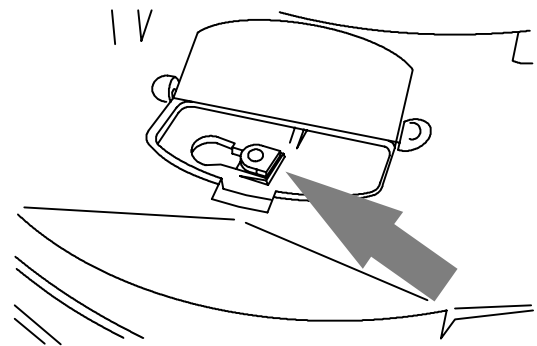

## OPERATION

---

5. Press down on the brush lock pin.

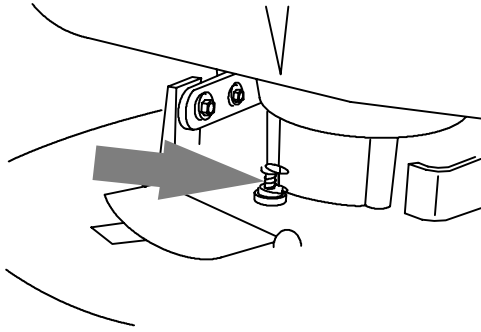

6. Turn the brush clockwise. The brush will drop off the brush drive hub.

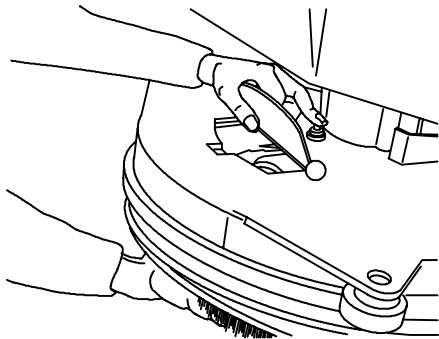

7. Pull the brush out from under the scrub head.  
8. Place the scrub brush on the floor in front of the scrub head. Make sure one of the brush drive pins is facing front. Push the brush under the scrub head.

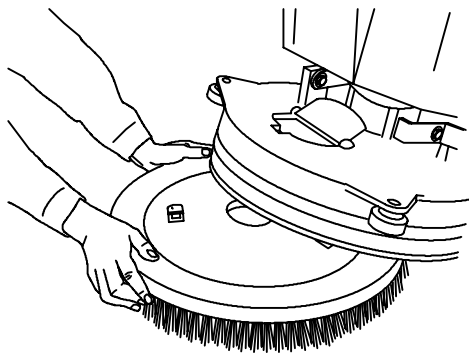

9. Make sure one of the drive pin slots can be seen through the access opening.

10. Line up the brush drive pin on the brush, with the drive pin slot on the drive plate.

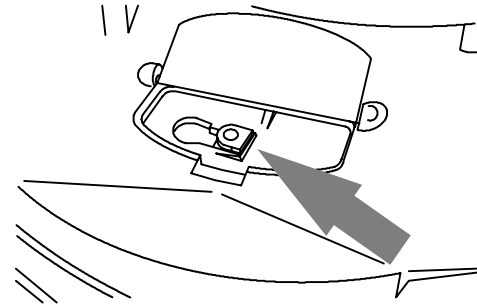

11. Lift the scrub brush from underneath onto the brush drive hub. Turn the brush counter-clockwise to engage the drive pins into the drive slots.  
12. Check the brush to make sure it is securely mounted on the brush drive hub.  
13. Close the scrub head access cover.

---

## SQUEEGEE

---

The squeegee channels water into the vacuum fan suction. The front blade channels the water, and the rear blade wipes the floor.

Check the squeegee blades for damage and wear daily. Rotate or replace either of the squeegee blades if the leading edge is torn or worn half-way through the thickness of the blade.

The squeegee can be adjusted for leveling and deflection. The deflection of the squeegee blades should be checked daily, or when scrubbing a different type of floor. The leveling of the squeegee should be checked every 100 hours of machine operation.

The squeegee can be removed from the squeegee pivot so the squeegee will not be damaged during transport of the machine.

---

## REMOVING THE SQUEEGEE

1. Turn the machine power off.

**FOR SAFETY: Before leaving or servicing machine, stop on level surface and turn off machine.**

2. Raise the squeegee.

- Remove the squeegee suction hose from the squeegee.

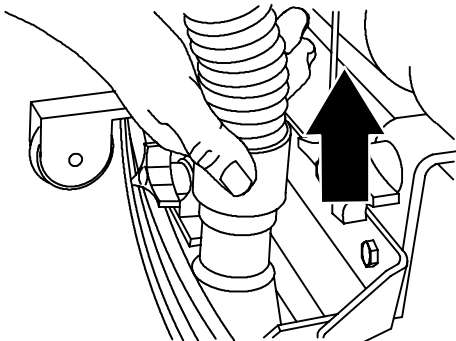

- Loosen the two mounting thumbscrews.

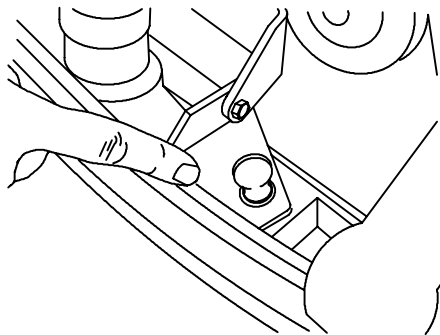

- Pull the squeegee off the machine.

## INSTALLING THE SQUEEGEE

- Make sure the squeegee is raised.
- Place the squeegee under the squeegee pivot.
- Line up the mounting studs on the squeegee, with the mounting slots on the squeegee pivot.
- Mount the squeegee to the squeegee pivot with the mounting thumbscrews.
- Replace the squeegee suction hose on the squeegee.

## LEVELING THE SQUEEGEE

Leveling of the squeegee assures even contact the length of the squeegee blade with the surface being scrubbed. Make sure this adjustment is done on an even, level floor.

- Turn the machine power on.
- Lower the squeegee.
- Drive the machine forward, then turn the machine power off.

- Look at the deflection of the squeegee blade, over the full length of the squeegee blade.

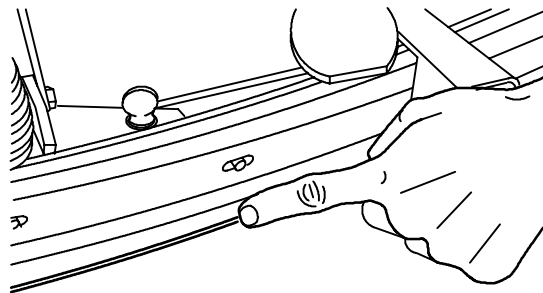

- If the deflection is not the same over the full length of the blade, turn the squeegee leveling knob counter-clockwise to decrease the deflection at the ends of the squeegee blade. Turn the squeegee leveling knob clockwise to increase the deflection at the ends of the squeegee blade.

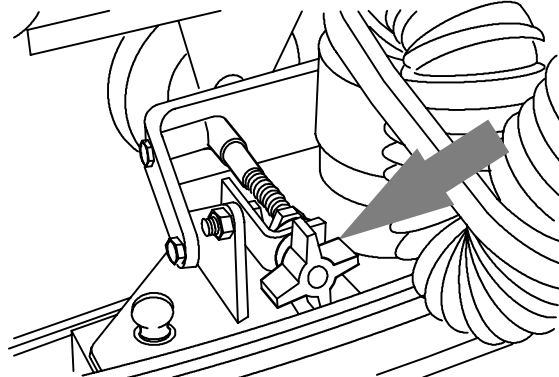

- Push the machine forward again to check the squeegee blade deflection.
- Readjust the squeegee blade deflection if necessary.

## ADJUSTING SQUEEGEE DOWN PRESSURE

Adjusting the squeegee down pressure allows for wiping different types of floor surfaces. Decrease down pressure for vinyl tile floor surfaces and increase down pressure when scrubbing rough and grouted tile floor surfaces.

**NOTE:** The use of maximum squeegee down pressure on smooth surfaces may cause drive wheel traction problems.

**NOTE:** Adjusting the down pressure will not affect the deflection of the blades. To adjust squeegee deflection, see **ADJUSTING SQUEEGEE DEFLECTION**.

## OPERATION

1. Turn machine power off.
2. To adjust the amount of down pressure, turn the squeegee down pressure knob counter-clockwise to decrease, and clockwise to increase.

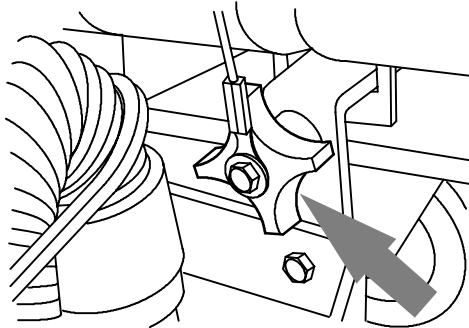

6. Push the machine forward again to check the squeegee blade deflection.
7. Readjust the squeegee blade deflection if necessary.

### ADJUSTING SQUEEGEE BLADE DEFLECTION

Deflection is the amount of curl the squeegee blade has when the machine moves forward with the squeegee lowered to the floor. The best deflection is when the squeegee wipes the floor just dry with a minimum amount of deflection.

1. Turn the machine power on.
2. Lower the squeegee.
3. Drive the machine forward, and look at the deflection of the squeegee blade. The correct amount of deflection is 12 mm (0.50 in.) for scrubbing smooth floors and 15 mm (0.62 in.) for rough floors.

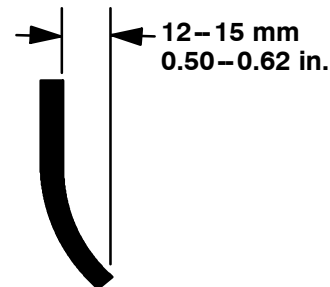

4. Turn the machine power off.
5. To adjust the blade deflection, loosen the nut that secures the squeegee support wheel. Once loosened, the wheel can be adjusted within the slot on the wheel mounting bracket. Raise wheel to increase deflection or lower to decrease.

### SQUEEGEE BLADES

The squeegee has two squeegee blades. The front blade has two wiping edges. To use both of them, rotate the blade end-for-end.

The rear blade has four wiping edges. To use them all, start with one wiping edge. To use the next wiping edge, rotate the blade end-for-end. To use the next wiping edge, rotate the top edges down, bottom edges up. To use the last edge, rotate the blade end-for-end.

Replace any worn or damaged squeegee blades.

### REPLACING OR ROTATING THE FRONT SQUEEGEE BLADE

1. Turn the machine power off.

**FOR SAFETY: Before leaving or servicing machine, stop on level surface and turn off machine.**

2. Make sure the squeegee is raised off the floor.
3. Remove the six thumbscrews holding the retainer and squeegee blade to the squeegee frame.

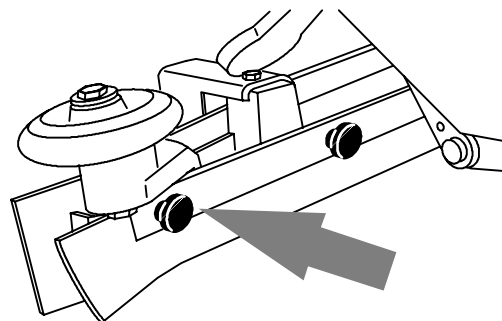

4. Pull the squeegee blade off the squeegee frame.
5. Rotate the squeegee blade end for end to allow a new edge to face the front of the machine.
6. Line up the squeegee blade and the retainer to the squeegee frame
7. Secure the blade and retainer to the squeegee frame with the six thumbscrews.

---

## REPLACING OR ROTATING THE REAR SQUEEGEE BLADE

1. Turn the machine power off.

**FOR SAFETY: Before leaving or servicing machine, stop on level surface and turn off machine.**

2. Make sure the squeegee is raised off the floor.
3. Loosen the retainer clamp and remove the retainer from the squeegee frame.

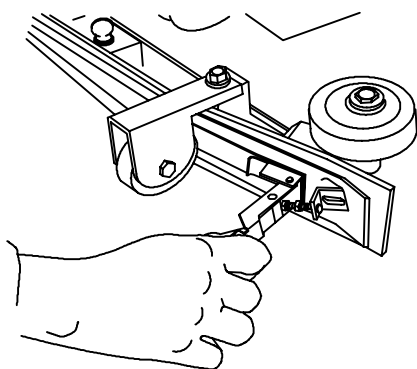

4. Remove the squeegee blade and backup strip from the squeegee frame.
5. Replace or rotate the squeegee blade to allow a new edge to face the front of the machine.
6. Place the squeegee blade and backup strip on the squeegee frame
7. Secure the squeegee blade and backup strip with the retainer. Tighten the retainer clamp.
8. Adjust the squeegee blade leveling and deflection as stated in *LEVELING THE SQUEEGEE* and *ADJUSTING SQUEEGEE BLADE DEFLECTION*.

---

## MACHINE JACKING

Check that both the solution tank and recovery tanks are empty before attempting to jack up the machine.

You can jack up the machine for servicing anywhere under the solution tank. Use a piece of wood to distribute the machine weight load.

Always jack machine on a flat level surface and block machine tires before jacking up machine.

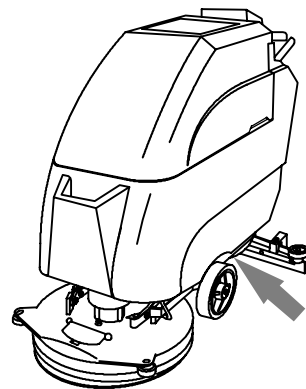

**FOR SAFETY: When servicing machine, block machine tires before jacking machine up. Jack machine up at designated locations only. Block machine up with jack stands. Use hoist or jack of adequate capacity to lift machine.**

---

## TRANSPORTING MACHINE

When transporting machine by use of trailer or truck, be certain to follow tie-down procedures below:

**FOR SAFETY: When using machine, go slow on inclines and slippery surfaces.**

1. Raise squeegee and scrub head.
2. Load machine using a recommended loading ramp.
3. Position front of machine up against front of trailer or truck. Once machine is positioned, lower scrub head and squeegee.
4. Place a block behind each drive wheel to prevent machine from rolling.
5. Secure machine using tie-down brackets located at rear of machine frame, if equipped. It may be necessary to install tie-down brackets to the floor of your trailer or truck.
6. Place tie-down straps over top of machine to prevent it from tipping.

**NOTE: Do not use control grips to secure machine for transporting.**

**FOR SAFETY: When transporting machine, use a recommended ramp when loading/unloading into/off truck or trailer, use tie-down straps to secure machine to truck or trailer.**

# OPERATION

## STORAGE INFORMATION

The following steps should be taken when storing the machine for extended periods of time.

1. Drain and clean the solution and recovery tanks.
2. Park the machine in a cool, dry area.
3. Remove the batteries, or charge them after every three months.

## FREEZE PROTECTION

1. Be sure the solution tank and recovery tank are empty.
2. Pour 3.8 L of pre-mixed automotive-type windshield washer solution into the solution tank.
3. Turn the machine power on.
4. Start the solution flow.
5. The washer solution does not need to be drained from the solution tank.

## MACHINE DIMENSIONS

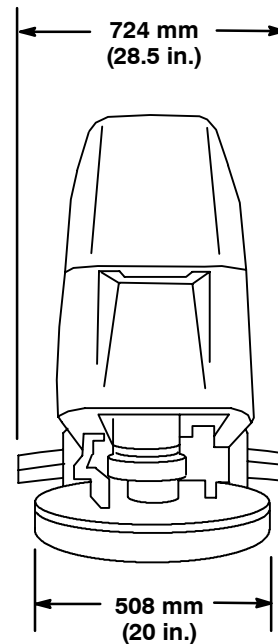
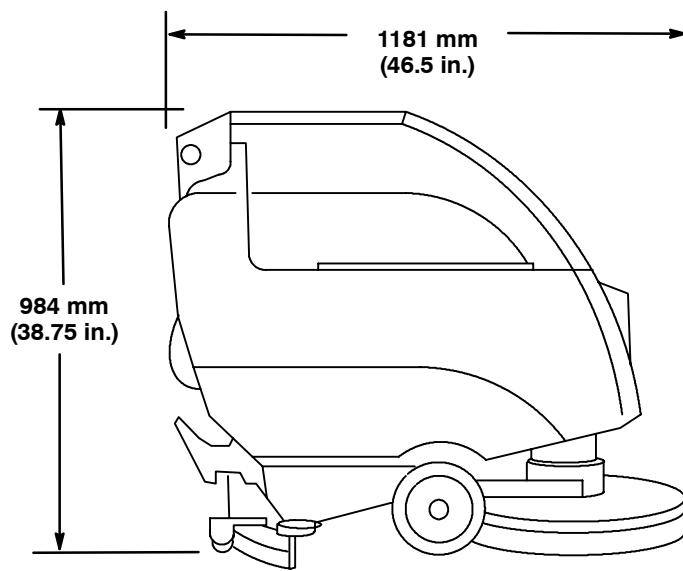

## RECOMMENDED STOCK ITEMS

Refer to the Parts List Manual for recommended stock items. Stock Items are clearly identified with a bullet preceding the parts description. See example below:

Ref.	Part No.	Description	Qty.
1	701103	ASM., STANDPIPE	1
2	180618	•FLOAT, SHUTOFF	1
3	230197	NIPPLE	1
4	101714	•GASKET	1
5	210240	NUT, FLANGED	1

**TROUBLESHOOTING**

<b>PROBLEM</b>	<b>CAUSE</b>	<b>SOLUTION</b>
Trailing water – poor or no water pickup.	Worn squeegee blades.	Rotate or replace squeegee blades.
	Squeegee out of adjustment.	Adjust squeegee.
	Vacuum hose clogged.	Flush vacuum hoses.
	Recovery tank full.	Drain recovery tank.
	Vacuum fan will not turn on.	Drain recovery tank.
		Reset vacuum fan circuit breaker.
	Debris caught on squeegee.	Remove debris.
	Foam filling recovery tank.	Empty recovery tank; use less or change detergent
	Vacuum hose to squeegee or recovery tank disconnected or damaged.	Reconnect or replace vacuum hose.
	Recovery tank float screen clogged.	Clean screen.
Recovery tank cover not closed completely.	Close cover.	
Little or no solution flow to the floor.	Solution tank empty.	Fill solution tank.
	Solution switch off.	Turn switch on.
	Solution control cable broken or out of adjustment.	Replace and/or adjust cable.
	Solution flow knob turn off.	Turn solution flow knob on.
	Solution supply lines plugged.	Flush solution supply lines.
	Solution solenoid clogged or stuck.	Clean or replace.
	ES (Extended Scrub) mode: ES switch off.	Turn ES switch on.
Poor scrubbing performance.	Debris caught on scrub brushes.	Remove debris.
	Improper detergent, brush, or pad used.	Check with TENNANT representative for advice.
	Worn scrub brush or pad.	Replace scrub brush or pad.
	Scrub brush motor circuit breaker tripped.	Reset circuit breaker.
		Adjust scrub brush down pressure, check with TENNANT representative for advice.
	Low battery charge.	Charge batteries.
	Low scrub brush down pressure.	Adjust scrub brush down pressure, check with TENNANT representative for advice.

# OPERATION

---

## SPECIFICATIONS

### GENERAL MACHINE DIMENSIONS/CAPACITIES

Item	Dimension/capacity
Length	1181 mm (46.5 in)
Width (less squeegee)	546 mm (21.5 in)
Height	984 mm (38.75 in)
Scrub brush diameter	508 mm (20 in)
Squeegee width	724 mm (28.5 in)
Scrubbing path width	508 mm (20 in)
Solution tank capacity	45 L (12 gal)
Recovery tank capacity	49 L (13 gal)
Net weight, less batteries	104 kg (225 lb)

### GENERAL MACHINE PERFORMANCE

Item	Measure
Aisle turnaround width	1525 mm (60 in)
Turning radius	735 mm (29 in)
Maximum trailer loading clearance angle	5°

### POWER TYPE

Type	Quantity	Volts	Ah Rating	Weight
Batteries	2	12	130 @ 20 hr rate	30 kg (66 lb) each
Batteries	2	12	215 @ 20 hr rate	55 kg (122 lb) each

Type	Use	VDC	Kw (hp)
Electric Motors	Scrub brush	24	0.56 (0.75)
	Vacuum fan	24	0.56 (0.75)
	Drive	24	0.15 (0.20)

Type	VDC	amp	Hz	Phase	VAC
Chargers	24	20	60	1	115

### TIRES

Location	Type	Size
Front (2)	Wheels Solid, non-marking	8 x 2 in
Rear (1)	Casters Solid, non-marking	4 x 1.38 in



# ELECTRICAL DIAGRAMS

## WIRING DIAGRAM

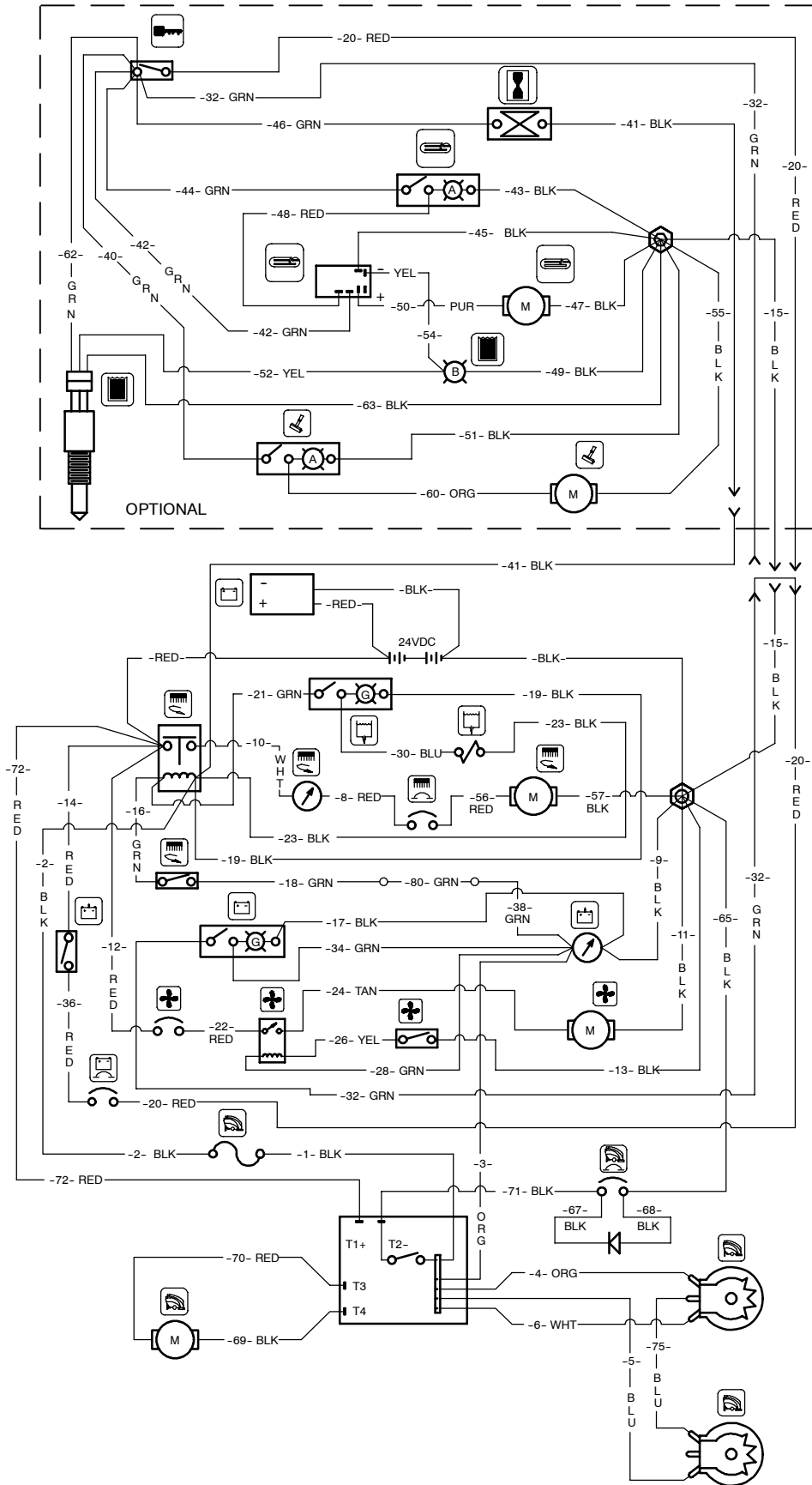

LADDER DIAGRAM

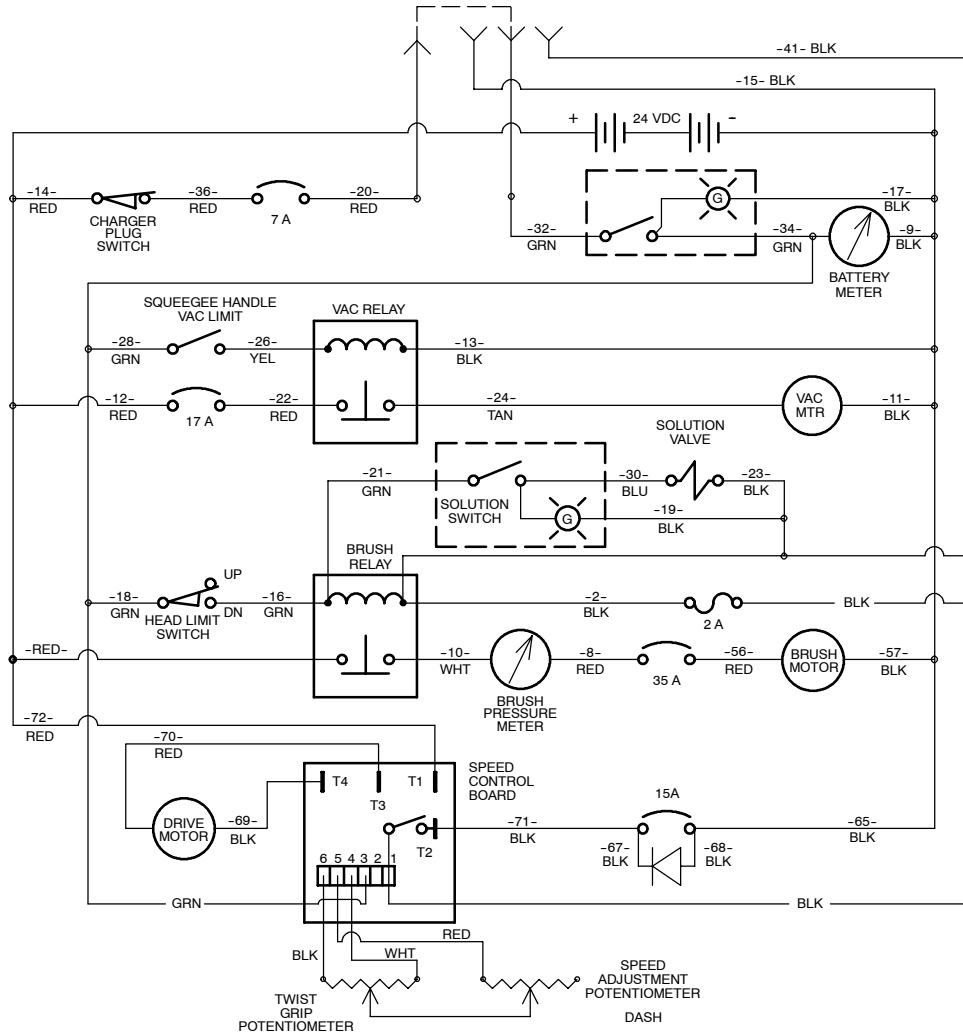
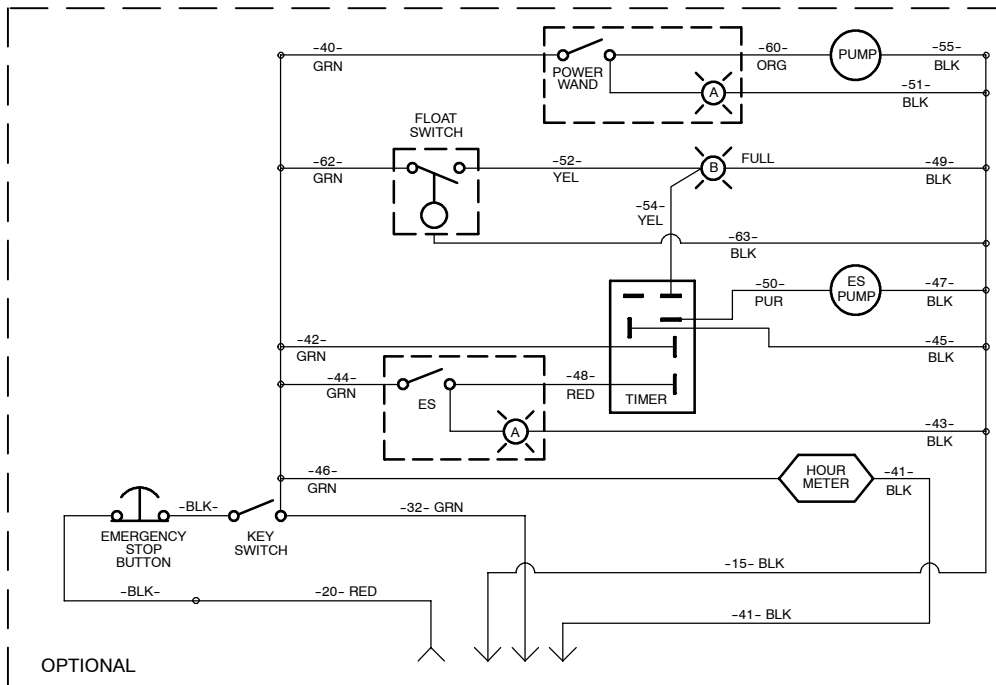

REPLACEMENT BRUSHES AND PAD DRIVER GROUP

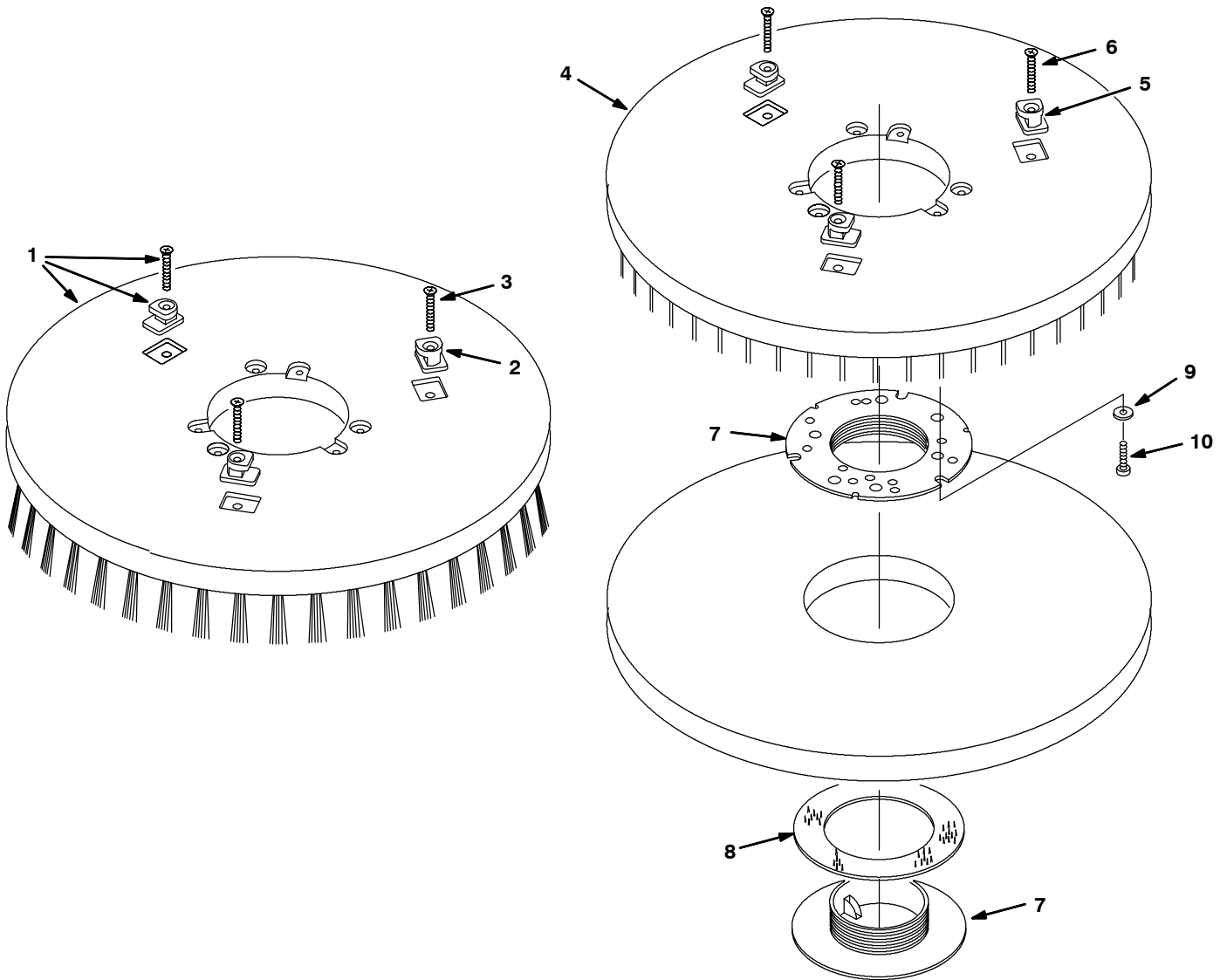

## REPLACEMENT BRUSHES AND PAD DRIVER GROUP

REF	PART #	DESCRIPTION	QTY.
▽ 1	222301	BRUSH ASM, 20" NYLON	1
▲ 2	630214	●STUD, 20" BRUSH/PAD DRIVER	3
▲ 3	66016	SCREW, FLT, M6X1.0X40, 4.8	3
▽ 1	222300	BRUSH ASM, 20" POLYPROPYLENE	1
▲ 2	630214	●STUD, 20" BRUSH/PAD DRIVER	3
▲ 3	66016	SCREW, FLT, M6X1.0X40, 4.8	3
▽ 1	222302	BRUSH ASM, 20" ABRASIVE GRIT	1
▲ 2	630214	●STUD, 20" BRUSH/PAD DRIVER	3
▲ 3	66016	SCREW, FLT, M6X1.0X40, 4.8	3

REF	PART #	DESCRIPTION	QTY.
▽ 4	222303	●PAD DRIVER ASM, 20" PLAS BACK	1
▲ 5	630214	●STUD, 20" BRUSH/PAD DRIVER	3
▲ 6	66016	SCREW, FLT, M6X1.0X40, 4.8	3
▲ 7	32506	●PAD, HOLDER	1
▲ 8	32505	WASHER, 3.60B 5.65D .06 BRUSH PAD	1
▲ 9	41579	WASHER, FLAT, #08 SS	3
▲ 10	04403	SCREW, PAN, M4X0.7X25, SS, NL	3

▽ ASSEMBLY

▲ INCLUDED IN ASSEMBLY

● RECOMMENDED STOCK ITEMS

SOLUTION TANK AND VACUUM MOTOR GROUP

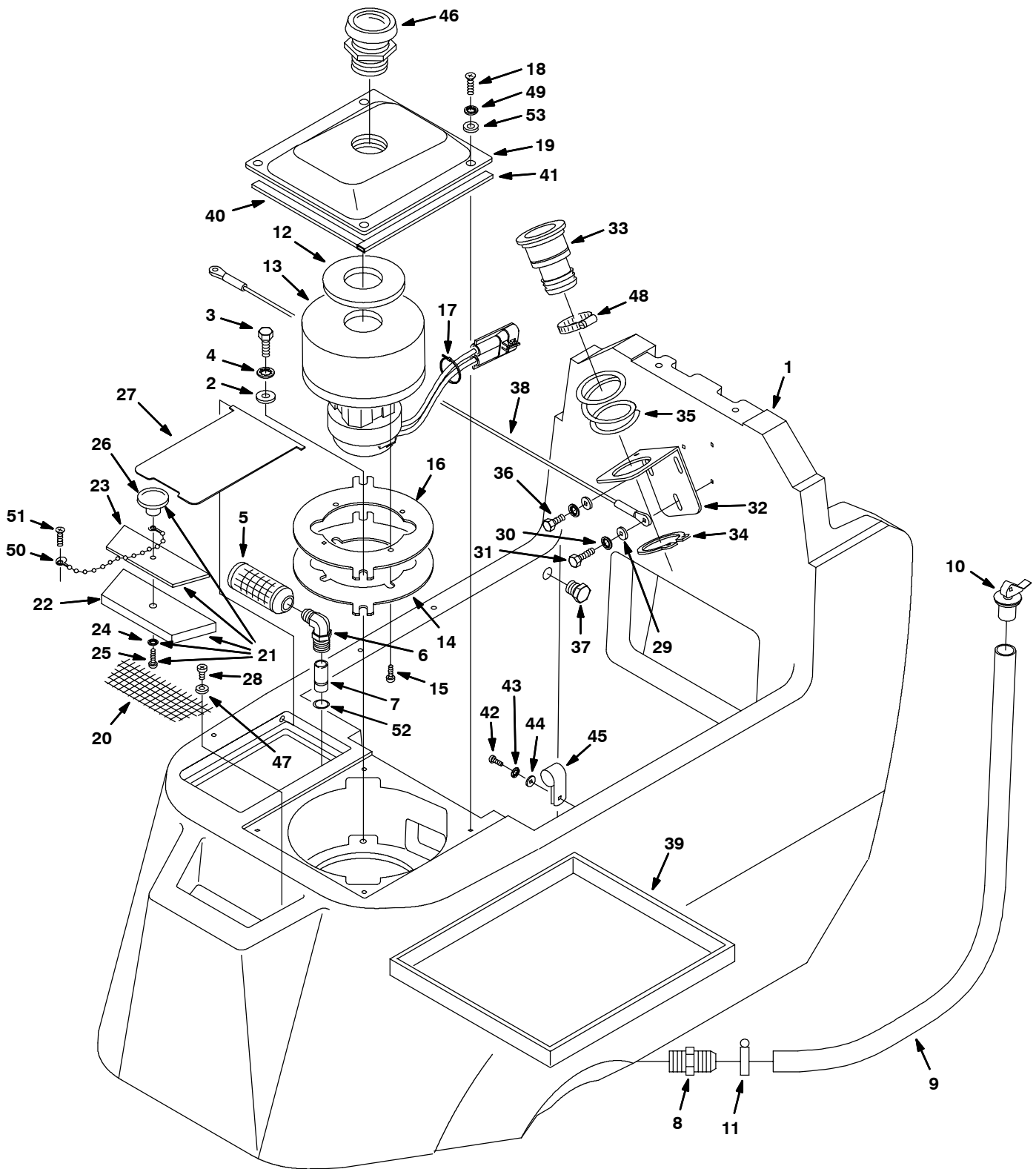

## SOLUTION TANK AND VACUUM MOTOR GROUP

REF	PART #	DESCRIPTION	QTY.
1	602695	TANK, SOLUTION, DK. GRAY	1
	602698	TANK, SOLUTION, TEAL	1
2	32491	WASHER, FLAT, 0.31 STD	2
3	16931	SCREW, HEX, M8X1.25X20, 8.8	2
4	200370019	WASHER, M8.4 LOCK	2
5	630024	●FILTER, SCREEN	1
6	630371	FITTING, E90 BM08/BM10	1
7	601105	SPACER, .50X.62X1.62	1
8	612146000	FITTING, 3/4M X 3/4H STRT	1
9	630018	HOSE, 3/4ID X 33"	1
10	630019	●PLUG, EXPANSION, 3/4"ID	1
11	630369	CLAMP, HOSE .50-1.1"	1
12	102557	●GASKET, VAC MOTOR SEAL	1
13	607003	●MOTOR, VAC 5.7 2-STAGE 24V	1
	190163	●BRUSH, CARBON 2/PK	1
14	630013	GASKET, VAC MOTOR BRACKET	1
15	140340	SCREW, #10X5/8	4
16	630014	BRACKET, VAC MOTOR 20"	1
17	130040	WIRE TIE, 6"X.12	1
18	608322	SCREW, M6X1.0X16	4
19	630015	COVER, VAC MOTOR 20"	1
20	630006	FILTER SCREEN	1
▽ 21	630602	KIT, FILL COVER ASM	1
▲ 22	630338	COVER, SOLUTION FILL	1
▲ 23	630341	STIFFENER, SOL FILL COVER	1
▲ 24	07514	WASHER, LOCK, INT, #10, SS	1
▲ 25	578201000	SCREW, 10-32X.5	1
▲ 26	578301	KNOB, FILL-COVER	1

REF	PART #	DESCRIPTION	QTY.
27	630007	DOOR, SOL TANK ACCESS	1
28	140872	SCREW, #6X3/8	2
29	579210	WASHER, M6.4X18X1.5 FLAT	3
30	578244000	WASHER, M6.4X10 LCK SS	3
31	200031441	SCREW, HEX, M6X1.0X25	1
32	630012	BRACKET, VAC TRANS MOUNT	1
33	630011	TUBE, VAC TRANS, FLANGE & BARB	1
34	630016	RING, RETAINING 1.82" DIA EXT	1
35	630267	SPRING, COMP 2.12X2.00	1
36	200031436	SCREW, M6X1.0X16	2
37	630146	FITTING, 3/8M PLUG	1
38	630021	CABLE ASM, TANK SUPPORT	1
39	601991	TRAY, BATTERY	1
40	630380	GASKET, 191MM VAC MTR COVER	2
41	630381	GASKET, 223MM VAC MTR	2
42	200070340	SCREW, M4X.7X8	2
43	02938	WASHER, LOCK, INT, 08, SS	2
44	200301014	WASHER, M4.3X10.1X1 FLAT	2
45	630343	CLAMP, CABLE 7/8ID	2
46	630017	FILTER, SCREEN, VAC FAN	1
47	140032	WASHER, #6 FLAT	2
48	140308	CLAMP, HOSE 1-5/16 TO 2-1/4	1
49	578244000	WASHER, M6.4X10 LCK SS	4
50	621443	CHAIN, BALL, #10X157L, SS	1
51	140826	SCREW, #6X3/4	1
52	630508	O-RING, 9.2 ID X 12.7 OD	1
53	19066	WASHER, FLAT, #10	4

▽ ASSEMBLY

▲ INCLUDED IN ASSEMBLY

● RECOMMENDED STOCK ITEMS

SOLUTION CONTROL GROUP

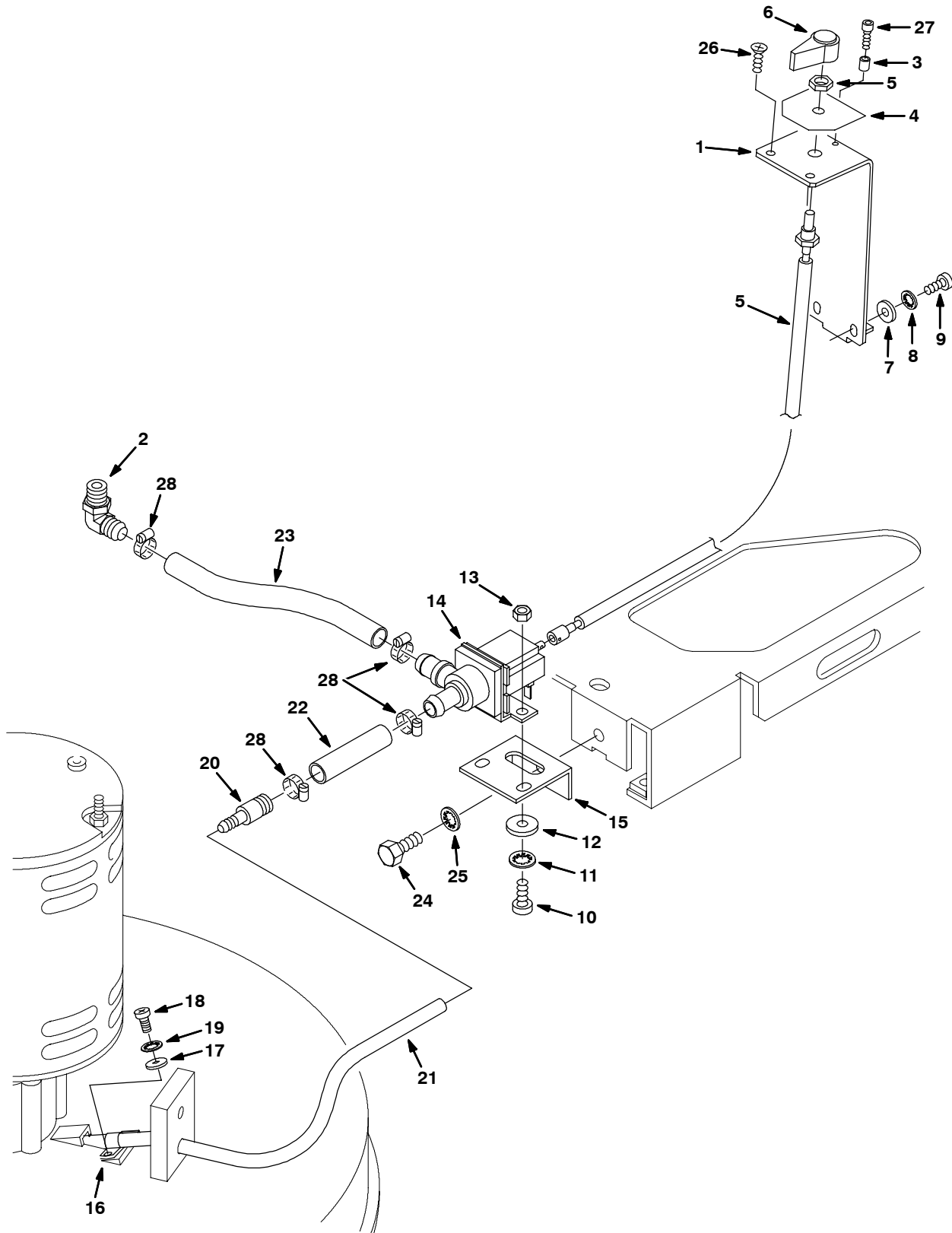

## SOLUTION CONTROL GROUP

REF	PART #	DESCRIPTION	QTY.
1	630057	BRACKET, SOL. ADJ. KNOB	1
2	1013505	FITTING, PLSTC, E90, PM08/BM08, NYL	1
3	630452	SPACER, 4.3MM, 8.0MM NYLON	1
4	630233	DECAL, FLOW CONTROL	1
5	630117	CABLE, CONT. WATER FLOW	1
6	630116	KNOB, ADJ, VALVE	1
7	200315016	WASHER, FLAT, 5.3MM, 15.0, 1.6	2
8	07514	WASHER, LOCK, INT, #10, SS	2
9	575569000	SCREW, M5X16	2
10	608322	SCREW, M6X1.0X16 TRSPHL	2
11	578244000	WASHER, M6.4X10 LCK SS	2
12	19066	WASHER, FLAT, #10	2
13	579029	NUT-HX STD M6X1.0	2
14	630022	●VALVE, SOLENOID, 24VDC	1
	614265	●KIT, VALVE, WATER, REBUILD	1

## ● RECOMMENDED STOCK ITEMS

REF	PART #	DESCRIPTION	QTY.
15	630059	BRACKET, VALVE	1
16	140328	CLAMP, 3/8" NYLON	1
17	200301014	WASHER, FLAT 4.3MM, 10.1, 1.0	1
18	579259	SCREW, M4X12MM	1
19	02938	WASHER, LOCK, INT, 08, SS	1
20	630164	FITTING, STR, BM08/BM04	1
21	630366	HOSE, .25IDX.345M	1
22	613509	TUBING, 1/2IDX3/4OD VINYL 611259 FT 0.16	0.132 FT.
23	613519	TUBING, 1/2IDX3/4OD VNYL 611259 FT 0.710	0.693 FT.
24	16931	SCREW, HEX, M8X1.25X20, 8.8	1
25	200370019	WASHER LOC INT M8	1
26	069764140	SCREW, M5X16MM	2
27	200001343	SCREW, M4X12MM	1
28	54333	CLAMP, HOSE, WORMDRIVE, 0.31-0.88D, .31W	4

RECOVERY TANK GROUP

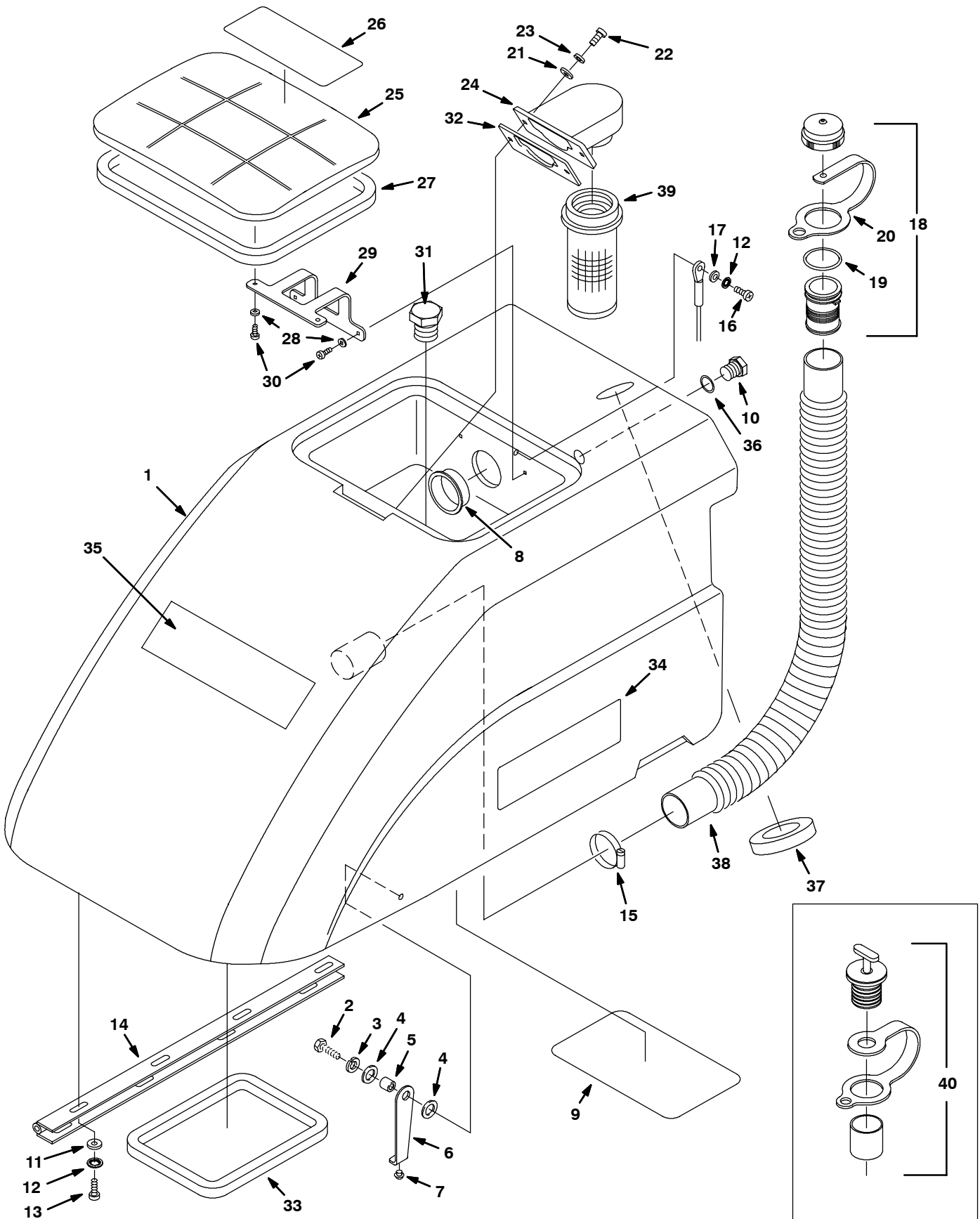

## RECOVERY TANK GROUP

REF	PART #	DESCRIPTION	QTY.
1	610932	TANK, RECOVERY, DK. GRAY	1
	610933	KIT, RECOVERY TANK, GRAY (FOR MACHINES MANUFACTURED BEFORE 11-00)	1
1	610935	TANK, RECOVERY, TEAL	1
	610936	KIT, RECOVERY TANK, TEAL (FOR MACHINES MANUFACTURED BEFORE 11-00)	1
2	200031486	SCREW, M8X1.25X16T	1
3	140015	WASHER, 5/16 SPLITLOCK	1
4	140027	WASHER, 5/16 FLAT	2
5	611418	BUSHING, .31X.44X.14	1
6	606527	SUPPORT, RECOVERY TANK	1
7	1014544	BUMPER, RBR	1
8	610979	PLUG	1
9	630231	DECAL, WIRING W/OPTIONS	1
10	630139	FITTING, PIPE, PLUG, BSP06 HEX	1
11	19066	WASHER, FLAT, #10	8
12	578244000	WASHER, M6.4X10 LCK SS	9
13	608322	SCREW, M6X1.0X16 TRSPHL	8
14	630048	HINGE, 17.9"	1
15	140308	CLAMP, HOSE	1
16	200031436	SCREW, M6X1.0X16	1
17	19066	WASHER, FLAT, #10	1
▽ 18	1008639	●CAP, DRAIN ASSY	1
▲ 19	1008637	●O-RING, 1.48"ID, 1.76"OD	1
▲ 20	1019563	●STRAP, DRAIN CAP	1

▽ ASSEMBLY

▲ INCLUDED IN ASSEMBLY

● RECOMMENDED STOCK ITEMS

REF	PART #	DESCRIPTION	QTY.
21	059650283	WASHER, M6.4X18X1.6 FLAT	2
22	600385	SCREW, M6X1.0X20	2
23	578244000	WASHER, M6.4X10 LCK SS	2
24	630053	MOUNT, FLOAT-CAGE	1
▽ 25	613716	ASM, LID & LABEL	1
▲ 26	613287	LABEL, WARNING DC WB BRN/SCR/EXT 6X2.25	1
▲ 27	630367	●GASKET, REC. TANK COVER	1
28	1009168	WASHER, FLAT, 0.17B 0.75D .04 SS	4
29	630056	STRAP, TANK COVER RET.	1
30	140872	SCREW, #6X3/8	4
31	630147	FITTING, PLUG, PM12	1
32	630255	●GASKET, FLOAT, MOUNT	1
33	630368	●GASKET, 650MM	1
34	630227	DECAL, 5300T	2
	608139	DECAL, 5300	2
35	630229	DECAL, TENNANT	1
36	630134	O-RING, 16MM OD X 3.5MM	1
37	630010	●GASKET, 70OD,43ID,12.7THK	1
38	630068	HOSE, DRAIN, 1.5DX32.0L, BLK EPDM	1
39	630052	●FLOAT, SHUT-OFF (2) BALL	1
40	N/A	CAP, DRAIN ASSEMBLY - REPLACED BY ASSEM. ITEM #18	1

CONSOLE GROUP

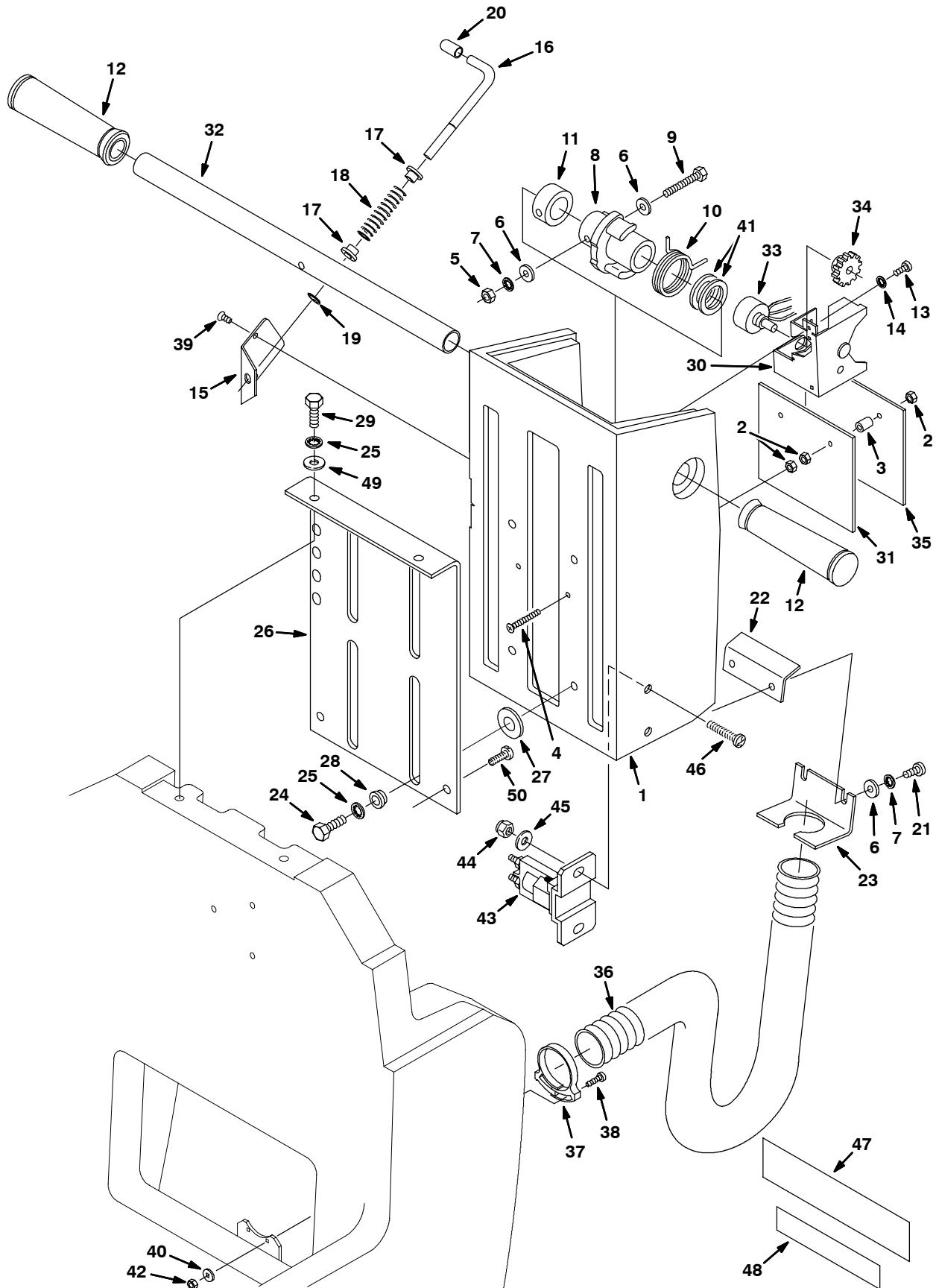

## CONSOLE GROUP

REF	PART #	DESCRIPTION	QTY.
▽	610923	KIT, CONSOLE, TEAL (FOR MACHINES MANUFACTURED BEFORE 11-00)	1
	610920	KIT, CONSOLE, DK. GRAY (FOR MACHINES MANUFACTURED BEFORE 11-00)	1
▲ 1	610922	CONSOLE, TEAL	1
	610919	CONSOLE, DK. GRAY	1
▲ 2	02850	NUT, HEX, LOCK, M4X0.7, NL	6
▲ 3	610943	SPACER, .217ID, .315OD, .375L	2
▲ 4	611895	SCREW, M4X40MM	2
5	579029	NUT, M6X1.0	1
6	579210	WASHER, FLAT, 6.4MM	4
7	578244000	WASHER, M6.4X10 LCK SS	3
8	630109	GEAR & HUB ASSY, 22.4ID, 20"SCR	1
9	630431	SCREW, M6X40MM	1
10	630088	SPRING, CENTERING	1
11	630217	COLLAR, .88ID 1.38OD .63LG	1
12	222648	GRIP, HANDLE, ROUND	2
13	200070340	SCREW, M4X8MM	2
14	02938	WASHER, LOCK, INT, 08, SS	2
15	630087	PLATE, RETAINER - LATCH	1
16	630081	LEVER, LATCH, CONSOLE ADJUST	1
17	630083	BUSHING, LATCH	2
18	630082	SPRING, COMP .42" 1.75 .035	1
19	630084	RING, RETAINING, EXT	1
20	630094	GRIP, LEVER-CONSOLE ADJUST	1
21	608322	SCREW, M6X1.0X16 TRSPHL	2
22	630086	PLATE, STRAIN RELIEF	1
23	630108	BRACKET, MTG, CONDUIT	1
24	200031486	SCREW, M8X16MM	4
25	200370019	WASHER LOC INT M8	6

● RECOMMENDED STOCK ITEMS

REF	PART #	DESCRIPTION	QTY.
26	582078	PLATE, CONSOLE SLIDE	1
27	20536-2	WASHER, FLAT, 0.47B 1.19D .03, NYL	4
28	630095	BEARING, FLNG .38" .50" .25"LG	4
29	16931	SCREW, HEX, M8X1.25X20, 8.8	2
30	630079	BRACKET, MTG, LIMIT SWITCH	1
31	630128	PLATE, PMC, HEAT SINK	1
32	630093	HANDLEBAR, .88OD 15.5LG	1
33	603372	●ASSEMBLY, POT. W/DECAL	1
34	630099	GEAR, 28T, 24P	1
35	630104	SPEED CONTROL, PMC BOARD, 55 AMP	1
36	630113	CONDUIT, CONVOLUTED	1
37	140322	CLAMP, VAC HOSE	1
38	578403000	SCREW, M3X20MM	2
39	630114	SCREW, M4X8MM	2
40	200301012	WASHER, FLAT, 3.2MM	2
41	069760582	WASHER, NYLON, 23 ID, 34 OD	2
42	579211	NUT, M3	2
43	603008	●CONTACTOR, 24VDC, 100A	1
44	140552	NUT, 10-24 NYLOCK	2
45	19324	WASHER, FLAT, #10 SAE	2
46	15858.12	SCREW, 10-24X3/4	2
47	601085000	DECAL, PMC CONNECTION	1
48	611440	DECAL, FUSE SPEC	1
49	140027	WASHER, FLAT 5/16	2
50	630306	SCREW, M8X16MM	2

CONSOLE PANEL GROUP

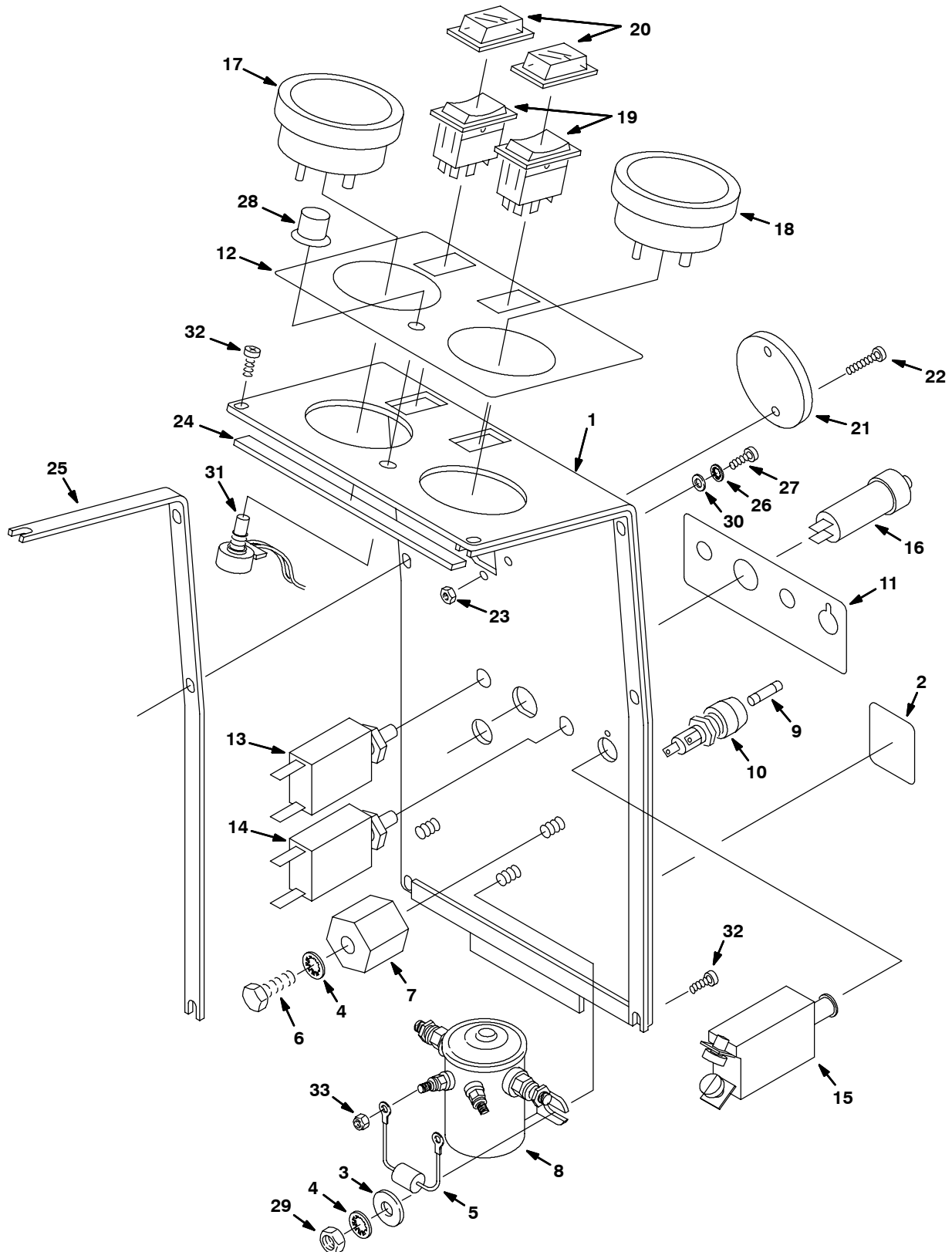

## CONSOLE PANEL GROUP

REF	PART #	DESCRIPTION	QTY.
1	602477	PLATE, SWITCH	1
2	606105	LABEL, HZRD, DO NOT SPRAY	1
3	140000	WASHER, FLAT 1/4"	2
4	578244000	WASHER, M6.4X10 LCK SS	3
5	606404	●ASM, DIODE W/RING TERMINALS	1
6	069762115	SCREW, 1/4-20X1/2	1
7	76062	INSULATOR, PANEL & SWITCHBOARD	1
8	605905AM	●SOLENOID, 24V	1
9	601091	●FUSE, 2AMP 3AG FAST BLOW	1
10	578418	HOLDER, FUSE	1
11	630241	DECAL, CIRCUIT BREAKERS	1
12	630243	DECAL, GAUGE/SWITCH PANEL	1
13	605197AM	●CIRCUITBREAKER, 15.0A, ETA	1
14	605201AM	●CIRCUITBREAKER, 17.0A 120VAC	1
15	602951AM	●CIRCUITBREAKER, 35.0A	1
16	630102AM	●CIRCUITBREAKER, 7.0A	1
17	630090AM	●GAUGE, BRUSH PRESSURE	1

● RECOMMENDED STOCK ITEMS

N/S = NOT SHOWN

REF	PART #	DESCRIPTION	QTY.
18	630091AM	●METER, BATTERY, 24VDC	1
19	630419	●SWITCH, ROCKER, SPST, 24VDC, GREEN	2
20	578720	●SPLASH GUARD, ROCKER SWITCH	2
21	607002	PLATE, COVER	1
22	200070340	SCREW, PAN HD, M4X8, ZP	2
23	02850	NUT, HEX, LOCK, M4X0.7, NL	2
24	630453	●GASKET, CONSOLE 143MM	2
25	630119	●GASKET, CONSOLE 3.1X8.0X420	2
26	02938	WASHER, LOCK, INT, 08, SS	4
27	200070340	SCREW, PAN HD, M4X8, ZP	4
28	630265	KNOB, SPEED LIMIT	1
29	14501	NUT, 1/4-20	2
30	200301014	WASHER, FLAT, 4.3,10.0, 1.0	4
31	630133AM	●RESISTOR, 0-20K, SPEED CONTROL	1
32	1009324	SCREW, PAN, #10-16X0.50, PHL, TY-17 BLK	4
33	575380	NUT, #10-32	2
N/S	607789	HARNESS, MAIN W/WATERPROOF	1

MAIN FRAME GROUP

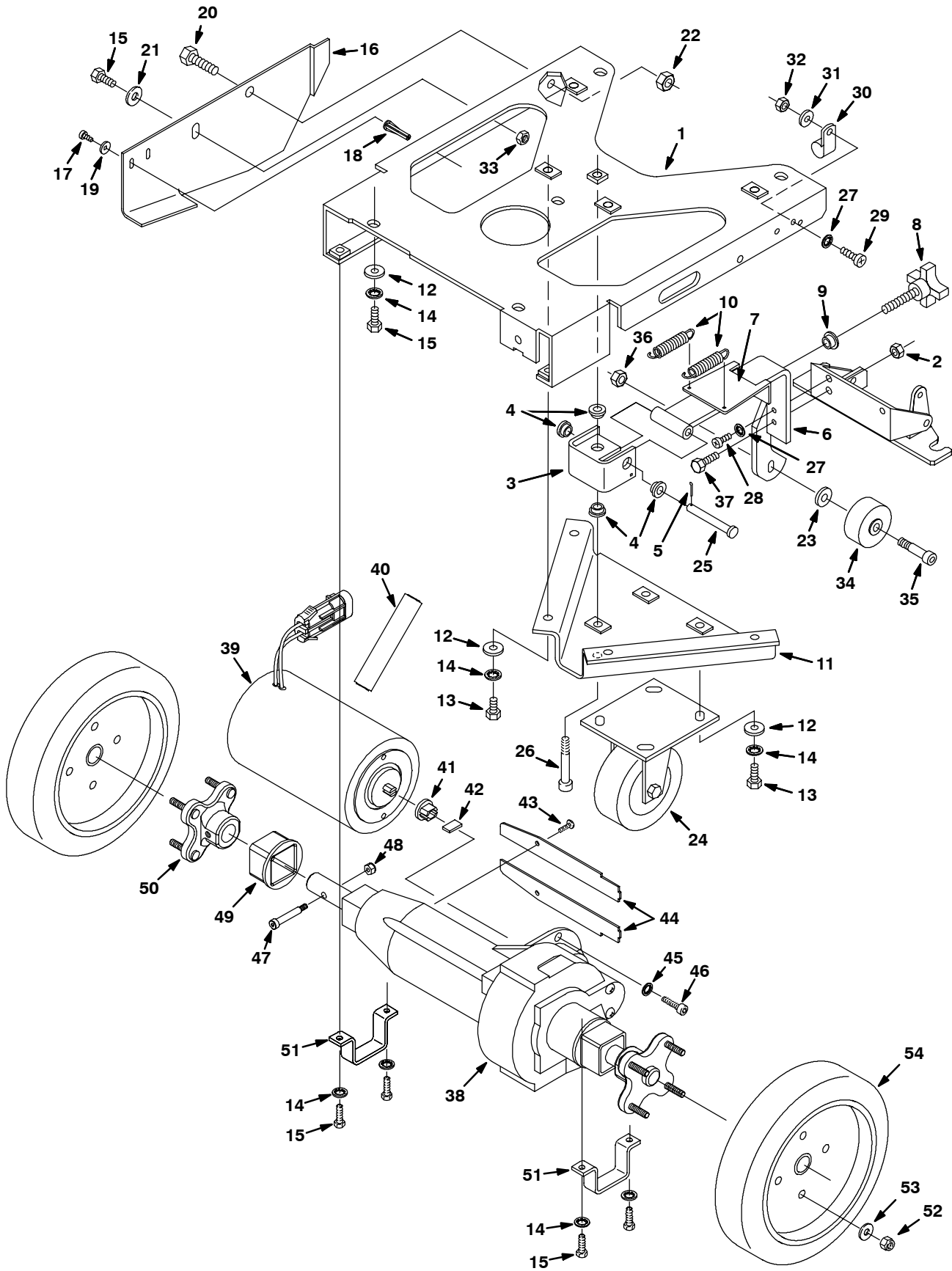

## MAIN FRAME GROUP

REF	PART #	DESCRIPTION	QTY.
1	630131	FRAME, 20"	1
2	08709	NUT, HEX, LOCK, M8X1.25, NL	1
3	630045	BRACKET, LIFT, SQUEEGEE	1
4	630095	BEARING, FLANGE	4
5	39005	PIN, COTTER, .094X0.75	1
6	630044	ARM, PIVOT, SQUEEGEE	1
7	630043	BRACKET, SPRING SLIDE	1
8	630046	KNOB, .38-24X2" LG STUD	1
9	630292	BEARING, KNOB, SQ. ARM	1
10	630042	SPRING, EXT.	2
11	630003	FRAME, MTG, CASTER	1
12	32491	WASHER, FLAT, 0.31 STD	13
13	200031486	SCREW, M8X1.25X16	8
14	200370019	WASHER, LOC INT M8	17
15	16931	SCREW, HEX, M8X1.25X20, 8.8	10
16	630307	BRACKET, SAFETY & LIMIT	1
17	590137	SCREW, #6-32X.38"	2
18	578329000	SCREW, ANCHOR	2
19	140032	WASHER, FLAT, #6	2
20	09291	SCREW, HEX, M10X1.5X20, SS	1
21	200303019	WASHER, M8 FLAT	1
22	41430	NUT, HEX, LOCK, M10X1.5, NL	1
23	200651019	WASHER, FLAT 8.4MM	1
24	1010388	●CASTER, SWIVEL, 4.0D 1.38W 5.28H	1
25	630047	PIN, CLEVIS .38 X 2.75	1
26	630345	BOLT, SHLDR .375 X 2.00	1
27	578244000	WASHER, M6.4X10 LCK SS	2
28	363503	SCREW, PAN, M6X1.0X12, SS	1
29	200031436	SCREW, HEX, M6X1.0X16	1
30	630428	CLAMP, CABLE	1
31	579210	WASHER, M6.4X18X1.5	1
32	579029	NUT, HEX STD, M6	1
33	08709	NUT, HEX, LOCK, M8X1.25, NL	1

REF	PART #	DESCRIPTION	QTY.
34	630477	WHEEL, SQUEEGEE SUPPORT	1
35	630478	SCREW, 3/8"X1.0	1
36	601108000	NUT, HEX LOCK, .31"-18	1
37	16931	SCREW, HEX, M8X1.25X20, 8.8	1
▽	1013312	●TRANSAXLE, 24V MOTOR 116 RPM	1
▲ 38	612873	TRANSAXLE, REPLMT, BODY ONLY	1
▲▽ 39	614165	●MOTOR, ELE, 24VDC TRANSAXLE REPLMNT	1
▲▲ 40	614166	●KIT, BRUSH CARBON QTY (4)	1
▲▲ 41	612874	COUPLING, TRANSAXLE REPLMT	-2
▲▲ 42	612875	KEY, SPECIAL, TRANSAXLE REPLMT	-2
▲▲ 43	577031000	SCREW, #8X1/2 PANPHL ZN	2
▲▲ 44	N/A	COVER, SHAFT	2
▲▲ 45	32982	WASHER, LOCK. INT. 0.25	2
▲▲ 46	<b>33951</b>	SCREW, SOC, <b>M6 x 20</b>	2
▲ 47	31249	BOLT, SHLD, .25D X 1.25, #10-24	2
▲ 48	140552	NUT, HEX, LOCK, #10-24, NL, SS	2
▲ 49	612880	SLEEVE, TRANSAXLE REPLMT	2
▲ 50	612879	HUB, WHEEL, TRANSAXLE REPLMT	2
51	630127	BRACKET, TRANSAXLE MT.	2
52	41169	NUT, HEX, LOCK, .25-20, NL, SS	8
53	140000	WASHER, FLAT	8
54	613026	●WHEEL, 8.0D 2.00W	2
	630215	●WHEEL, AIR FILLED	2
	600352	●WHEEL, FOAM FILLED	2
	606754	●KIT, WHEELS, NEOPRENE SOLID	1
	604357	●KIT, WHEELS, AIR FILLED	1
	604259	●KIT, WHEELS, FOAM FILLED	1
▽ N/S	613094	HARNESS, DRIVE WIRE	1
▲	607394	DIODE, .25 PIGGYBACK TERM.	1

▽ ASSEMBLY

▲ INCLUDED IN ASSEMBLY

● RECOMMENDED STOCK ITEMS

N/S = NOT SHOWN

SCRUB HEAD LIFT GROUP

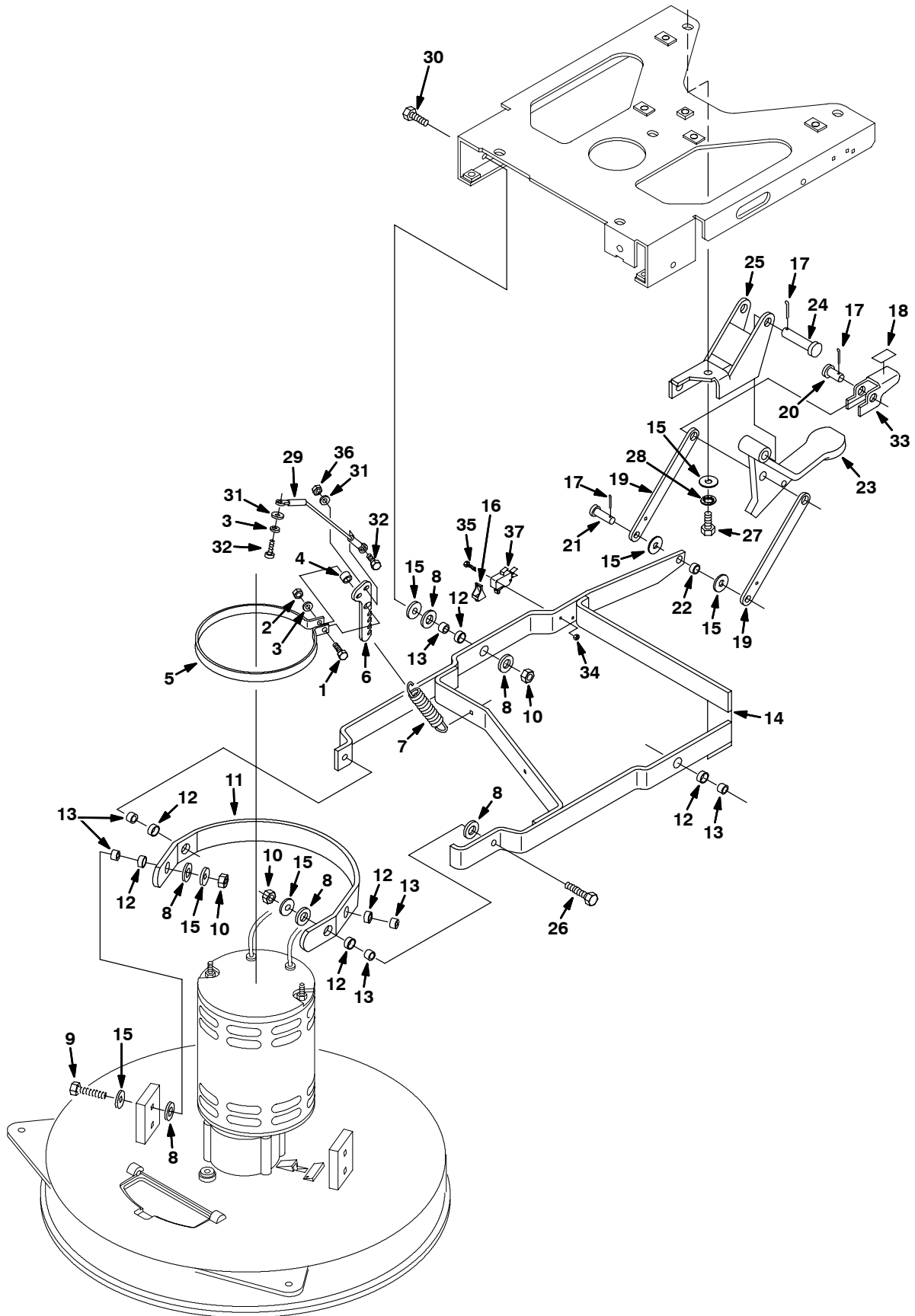

## SCRUB HEAD LIFT GROUP

REF	PART #	DESCRIPTION	QTY.
1	200031444	SCREW, M6X1.0X30	1
2	579029	NUT, M6X1.0	1
3	578244000	WASHER, M6.4X10 LCK SS	2
4	140154	SPACER, .25X.38X.31	1
5	630050	BAND, MOTOR SPRING MOUNT	1
6	630377	BRACKET, SCRUB HEAD LEVEL	1
7	630208	SPRING, MOTOR CNTR TORQUE	1
8	20536-2	WASHER, FLAT, 0.47B 1.19D .03, NYL	12
9	200031496	SCREW, M8X1.25X35	2
10	08709	NUT, HEX, LOCK, M8X1.25, NL	6
11	630177	BRACKET, MOTOR PIVOT	1
12	630188	BEARING .50"IDX.25LG JOURNAL	6
13	630189	SLEEVE, BRG 12.7ODX8.7ID 08	6
14	630176	HEAD LIFT, TRANSAXLE	1
15	32491	WASHER, FLAT, 0.31 STD	11
16	600372	BOOT, SWITCH	1
17	578421	PIN, COTTER 1/8X1"	3
18	600721	PAD, NON SLIP SURFACING	1
19	630182	ARM, LINK, HEADLIFT	2

REF	PART #	DESCRIPTION	QTY.
20	600720	PIN, CLEVIS 1/2DIAX1-19/64	1
21	630258	PIN, CLEVIS 3/8DIAX1"	1
22	630259	BEARING, 9.5ID, 12.7OD, 6.4LG	1
23	630181	PEDAL, FOOT, HEADLIFT	1
24	630448	PIN, CLEVIS 1/2DIAX2-1/4	1
25	630206	BRACKET, HEADLIFT ASM	1
26	200031494	SCREW, M8X1.25X30	2
27	16931	SCREW, HEX, M8X1.25X20, 8.8	1
28	200370019	WASHER, M8.4 LOCK	1
29	630384	CABLE, HEAD LIFT	1
30	09010	SCREW, HEX, M8X1.25X25, SS	2
31	19066	WASHER, FLAT, #10	2
32	200031436	SCREW, M6X1.0X16	2
33	600719	LATCH, HEAD RELEASE	1
34	579211	NUT, M3 HEXLOCK	2
35	579213	SCREW, M3X.5X20	2
36	08708	NUT, HEX, LOCK, M6X1.0, NL	1
37	611006	●KIT, SWITCH REPLACEMENT	1

## ● RECOMMENDED STOCK ITEMS

SCRUB BRUSH DRIVE GROUP

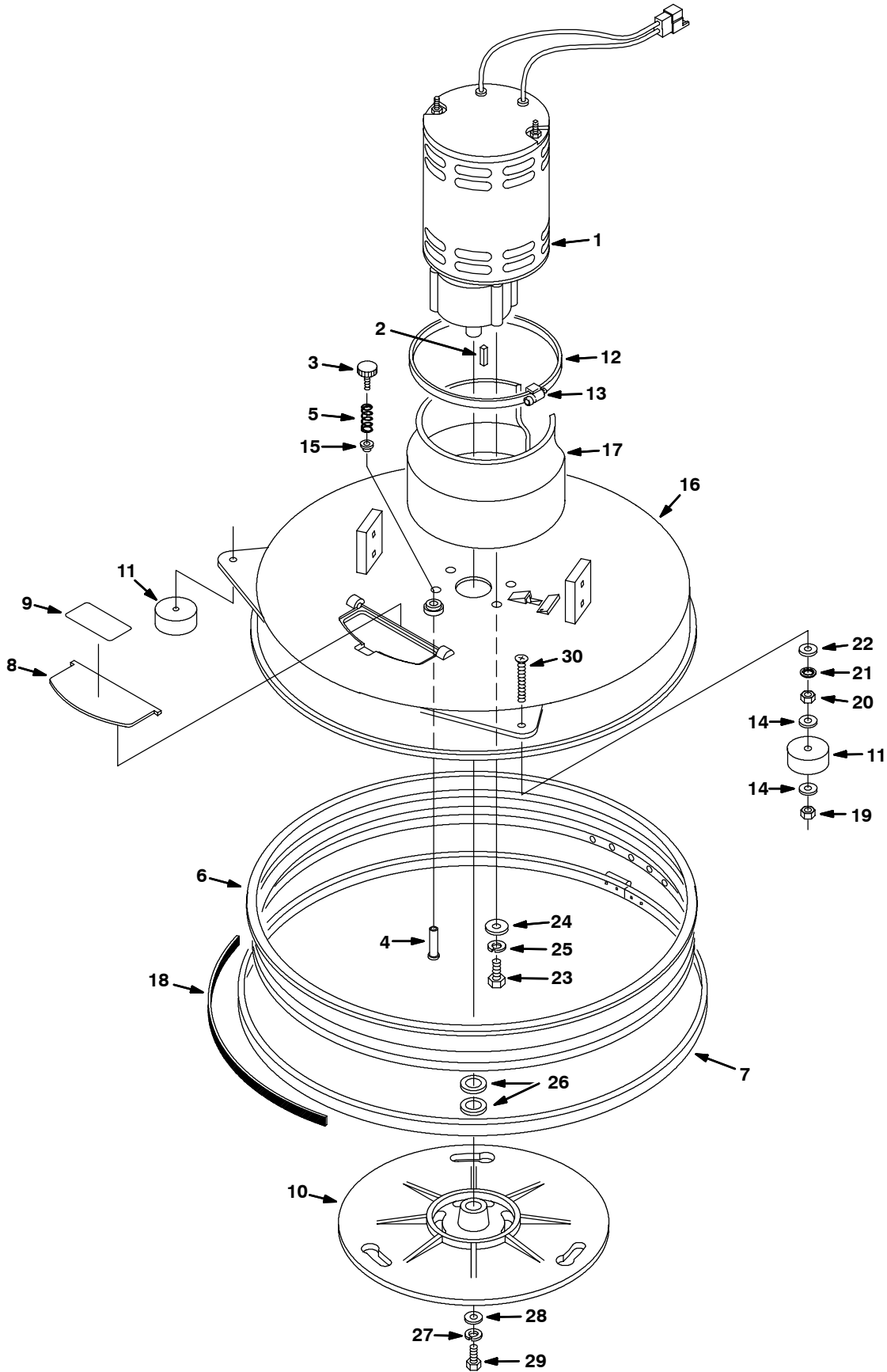

## SCRUB BRUSH DRIVE GROUP

REF	PART #	DESCRIPTION	QTY.
▽ 1	605054	●MOTOR, ELEC, 24VDC .75HP 270RPM (FOR BREAKDOWN SEE PAGE 68)	1
▲ 2	630454	KEY, SQUARE .25X1.12 LG	1
3	603012	KNOB, HUB LOCK	1
4	630308	PIN, HEAD STOP	1
5	630310	SPRING, HEAD STOP	1
6	613958	●SKIRT, SCRUBBER HEAD 20" (STD)	1
	630506	●SKIRT, SCRBR HEAD, HEAVY DUTY (OPT)	1
7	630049	STRAP ASSY, SKIRT (STD)	1
▽ 7	069767094	KIT, REPLMT. BAND, 68.5" (OPT)	1
▲	602044000AM	FASTENER, ADJUSTING	1
▽ 8	630603	KIT, BRUSH DOOR W/DECAL	1
▲ 9	578769	DECAL, MOVING PARTS	1
10	630039	HUB, DRIVE, BRUSH, 20", MACHND	1
11	579184	●WHEEL, 2.2D 0.88W .31B, RBR	2
12	606883	BAND, SS	1
13	602044000AM	FASTENER, ADJUSTING	1

REF	PART #	DESCRIPTION	QTY.
14	630446	WASHER, NYLON, .31"	4
15	605825	SCREW, HEAD STOP PIN	1
16	630026	HEAD, SCRUBBER 20"	1
17	611691	SHROUD, WATER DEFLECTOR	1
18	630613	SKID STRIP	1
19	08709	NUT, HEX, LOCK, M8X1.25, NL	2
20	200101017	NUT, M8X1.25 HEX JAM	2
21	200370019	WASHER, LOCK, INT., .08.4ID	2
22	32491	WASHER, FLAT, 0.31 STD	2
23	059650308	SCREW, 3/8-16X1.00	4
24	32492	WASHER, FLAT, 0.38 STD	4
25	140017	WASHER, SPLIT LOCK 3/8"	4
26	069760023	WASHER, FLT, .77"X1.26X.03	2
27	140015	WASHER, SPLIT LOCK 5/16"	1
28	069764631	WASHER, FLT, M8.4X25.4X4.8	1
29	140219	SCREW, 5/16-18X1	1
30	630430	SCREW, M8X1.25X50MM	2

▽ ASSEMBLY

▲ INCLUDED IN ASSEMBLY

● RECOMMENDED STOCK ITEMS

SCRUB BRUSH DOWN PRESSURE GROUP

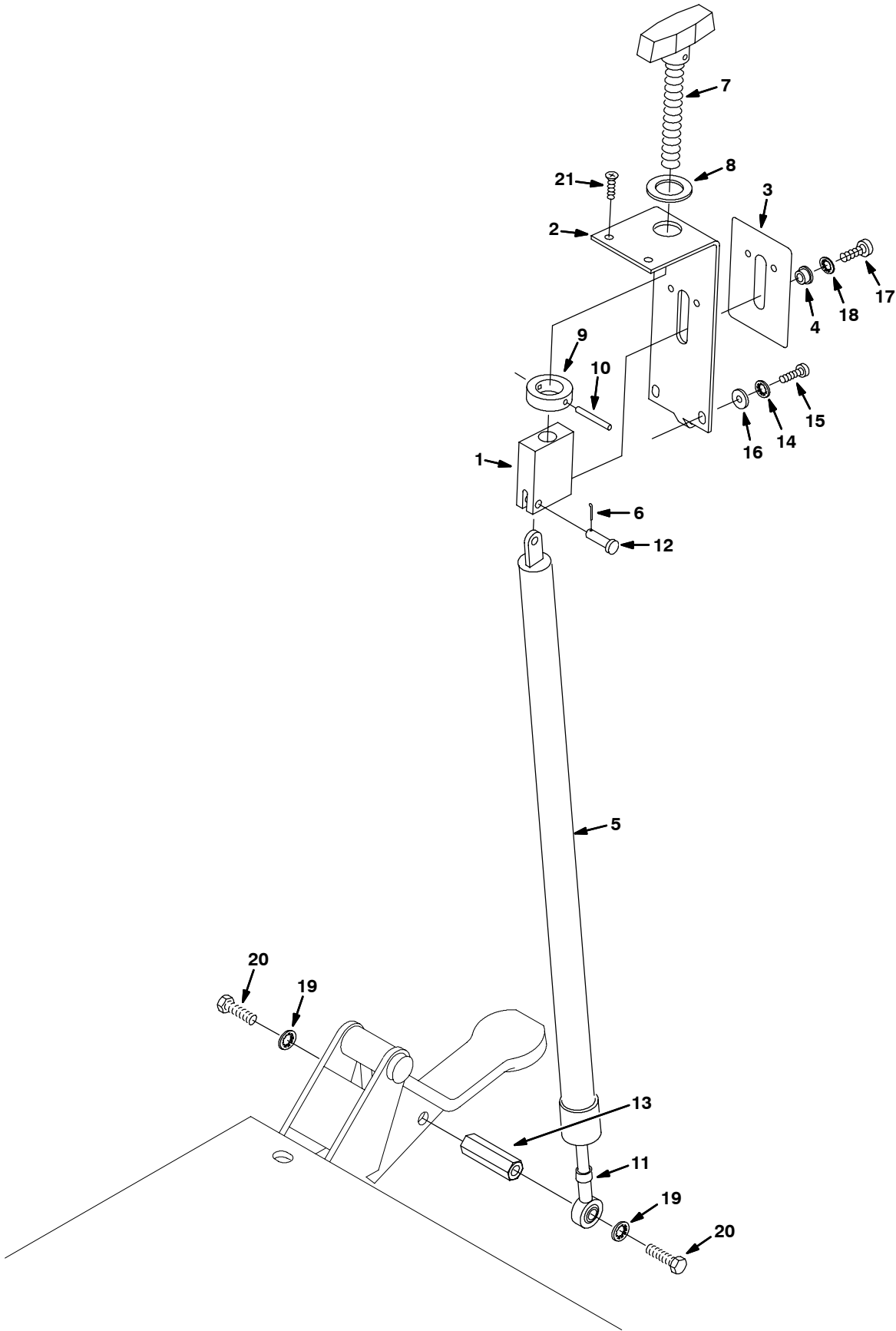

## SCRUB BRUSH DOWN PRESSURE GROUP

REF	PART #	DESCRIPTION	QTY.
1	630354	COUPLER, DOWN-PRESSURE SHOCK	1
2	630197	BRACKET, DOWN PRESS.	1
3	630234	DECAL, DOWN PRESSURE	1
4	630482	BEARING, FLANGE	1
5	612060	●SHOCK, DOWN PRESSURE DBL SEAL (VERS. 3)	1
6	39005	PIN, COTTER, .094X0.75	1
7	630195	KNOB, TEE, .50-13, 2-1/8"LG	1
8	630358	WASHER, NYLON .75" 1.0" .03TK	1
9	630355	COLLAR, 19.0ID 31.8OD 9.5W	1
10	630382	PIN, SPRING, .16" X 1.25"	1

REF	PART #	DESCRIPTION	QTY.
11	612776	ROD-END, SHORT	1
12	630357	PIN, CLEVIS	1
13	611378	SPACER, SHOCK	1
14	07514	WASHER, LOCK, INT, #10, SS	2
15	575569000	SCREW, PAN HD, PHIL, M5X16	2
16	200315016	WASHER, FLAT, 5.3MM, 15.0, 1.6	2
17	363503	SCREW, PAN, M6X1.0X12, SS	1
18	578244000	WASHER, M6.4X10 LCK SS	1
19	200370019	WASHER, M8.4 LCK, ZN	2
20	09010	SCREW, HEX, M8X1.25X25, SS	2
21	069764140	SCREW, M5X0.8X16 FLTPHL	2

● RECOMMENDED STOCK ITEMS

SQUEEGEE LIFT GROUP

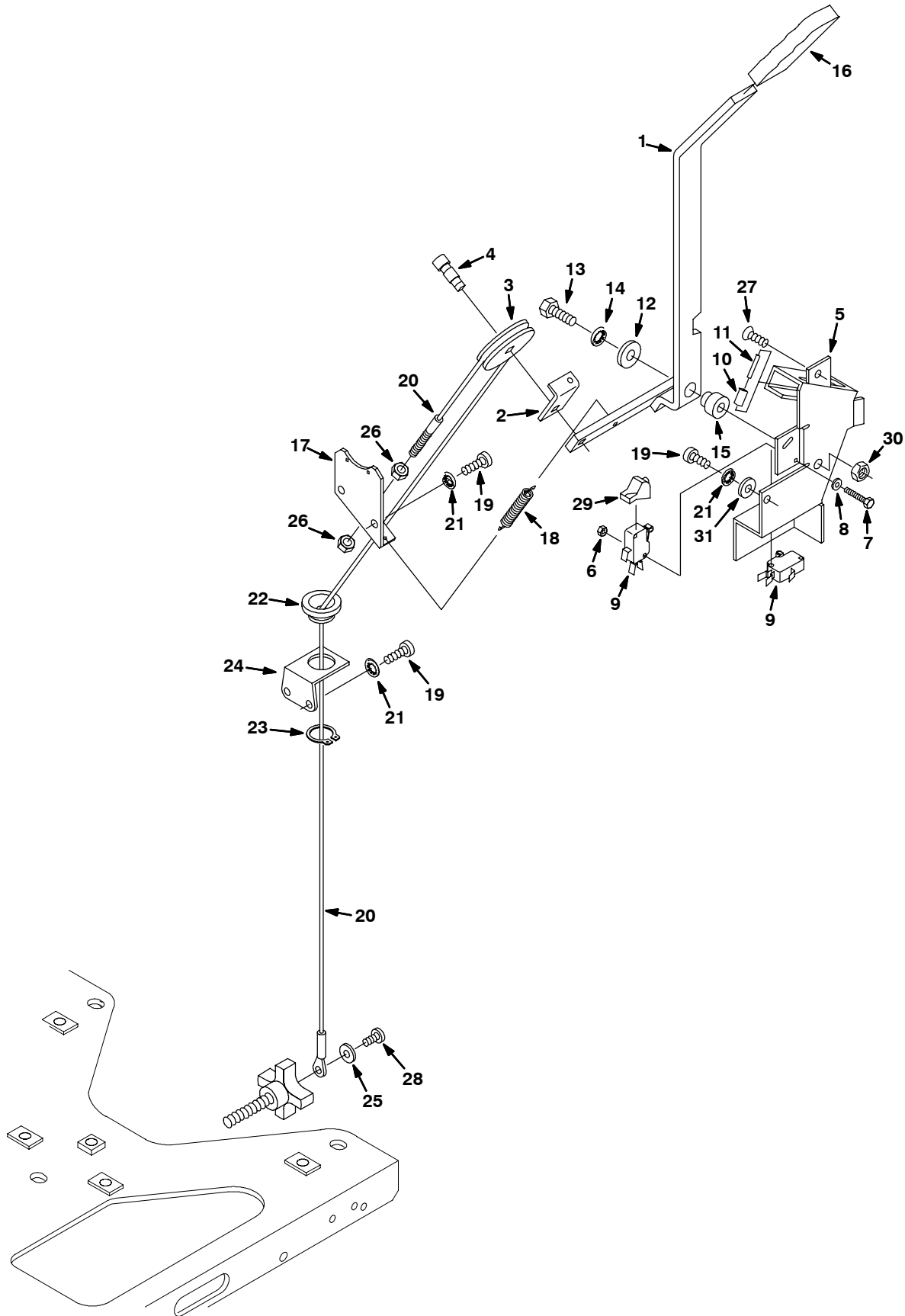

## SQUEEGEE LIFT GROUP

REF	PART #	DESCRIPTION	QTY.
1	630151	ARM, LIFT, SQUEEGEE	1
2	630427	BRACKET, SQUEEGEE SHEAVE	1
3	630426	PULLEY, CABLE 2"X3/16"	1
4	630470	SCREW, 5/16X3/8X1.00	1
5	630150	BRACKET, ARM, SQGE LIFT	1
6	579211	NUT, HEX LOCK, M3	4
7	579213	SCREW, M3X20MM	4
8	601127000	WASHER, FLT 3.7MM	4
9	611006	●KIT, SWITCH REPLACEMENT	2
10	630207	BUSHING, SQUEEGEE LIFT BRACKET	1
11	630262	PIN, ROLL .09D X .75LG	1
12	32490	WASHER, FLAT, 0.25 STD	1
13	200031496	SCREW, M8X1.25X35	1
14	200370019	WASHER LCK INT M8	1
15	630160	BUSHING, ARM, PIVOT	1

## ● RECOMMENDED STOCK ITEMS

REF	PART #	DESCRIPTION	QTY.
16	630209	GRIP, SQGE LIFT	1
17	630155	BRACKET, CABLE, SQGE	1
18	630158	SPRING, EXT .36 3.00 .45	1
19	608322	SCREW, M6X1.0X16	5
20	1015636	CABLE, SQUEEGEE LIFT	1
21	578244000	WASHER, M6.4X10 LCK SS	5
22	1009363	BUSHING, CABLE	1
23	621236000	RING, RETAINING .810 DIA	1
24	630157	BRACKET, CABLE GUIDE	1
25	140000	WASHER, FLAT 1/4"	1
26	32520	NUT, HEX, JAM, .25-20	2
27	069762098	SCREW, M6X16MM,	1
28	573268	SCREW, .25 20 X .75", SS	1
29	600372	BOOT, LIMIT SWITCH	2
30	07786	NUT, HEX, STD, M8X1.25, SS	1
31	19066	WASHER, FLAT, #10	1

SQUEEGEE GROUP

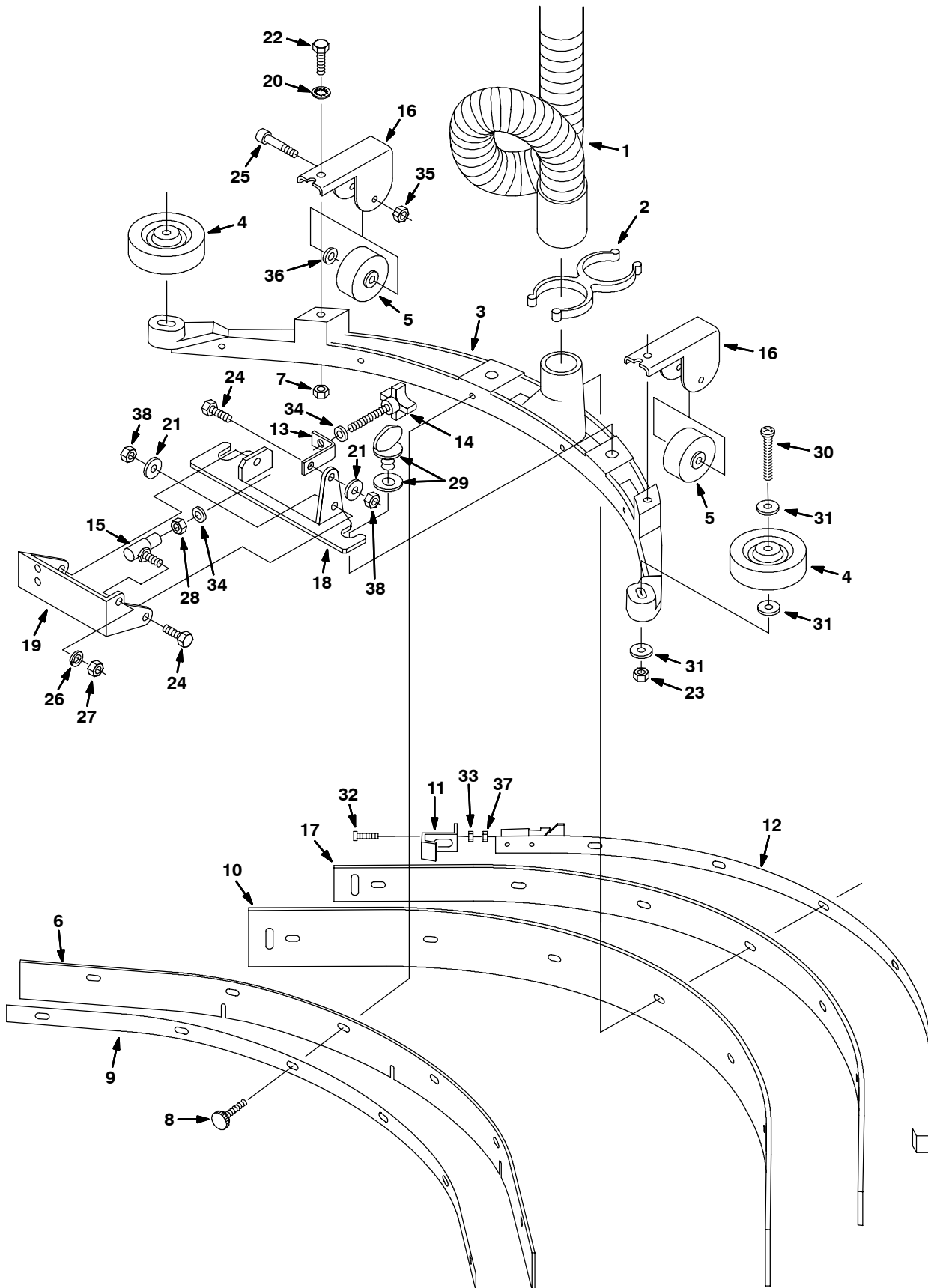

## SQUEEGEE GROUP

REF	PART #	DESCRIPTION	QTY.	
▽	630806	ASSY, SQUEEGEE	1	
1	630339	●HOSE ASSY, SQUEEGEE	1	
2	1014079	CLIP, HOSE, GRIPPER	1	
▲	3	630311	SQUEEGEE, CURVED	1
▲	4	1014918	●WHEEL, RBR, 3"X1" W/BUSHING	2
▲	5	579184	●WHEEL, 2.2D 0.88W .31B, RBR	2
▲	6	630291	●BLADE, FRONT SEMI GUM RBR	1
		600207	●BLADE, FRONT, URETHANE	1
		630288	●BLADE, FRONT, LINATEX	1
▲	7	07786	NUT, HEX, STD, M8X1.25, SS	2
▲	8	603012	KNOB, FRONT SQUEEGEE BLADE ASM	6
▲	9	630313	BAND, SQUEEGEE, FRONT	1
▲	10	630344	●BLADE, REAR, GUM RUBBER	1
		603511	●BLADE, REAR, URETHANE	1
		610150	●BLADE, REAR, LINATEX	1
▲	11	610850	CLIP, SQUEEGEE BAND	1
▲	12	630350	SQUEEGEE, BAND ASSY, CURVED	1
	13	630279	BRACKET, PIVOT, TIP ADJUST	1
	14	630281	KNOB, TIP ADJUST, SQGE	1
	15	140119	JOINT, BALL, LIFT ROD	1
▲	16	630314	BRACKET, SQGE BACKUP WHEEL	2
▲	17	630340	BLADE, SQGE, REAR, NEOPRENE	1

REF	PART #	DESCRIPTION	QTY.	
	18	630277	BRACKET, SQUEEGEE ATTACH.	1
	19	630278	BRACKET, TIP ADJUST	1
▲	20	200370019	WASHER LCK INT M8	2
	21	200303019	WASHER, FLAT, 8.4MM	3
▲	22	200031494	SCREW, M8X30MM	2
▲	23	08709	NUT, HEX, LOCK, M8X1.25, NL	2
	24	16931	SCREW, HEX, M8X1.25X20, 8.8	3
▲	25	630480	SCREW, SHLD., .31DX1.25, .25-20	2
	26	140015	WASHER, LOCK, 5/16"	1
	27	140508	NUT, 5/16-24 HEX ZN	1
	28	630388	NUT, HEX LOCK, 5/16-24	1
▲	29	630393	●SCREW, THUMB & WASHER ASM	2
▲	30	630424	SCREW, M8X70MM	2
▲	31	630303	WASHER, FLT 8.4 25.4 2.0	6
▲	32	630389	SCREW, M5X.8X45MM	1
▲	33	09739	NUT, HEX, LOCK, M5X0.8, NL, SS	1
	34	630446	WASHER, NYLON, .31"	2
▲	35	41169	NUT, HEX, LOCK, .25-20, NL, SS	2
▲	36	200651019	WASHER, M8.4X17X1.6 FLAT	2
▲	37	140297	NUT, M5X.8	1
	38	08709	NUT, HEX, LOCK, M8X1.25, NL	3

▽ ASSEMBLY

▲ INCLUDED IN ASSEMBLY

● RECOMMENDED STOCK ITEMS

BATTERY AND CHARGER GROUP

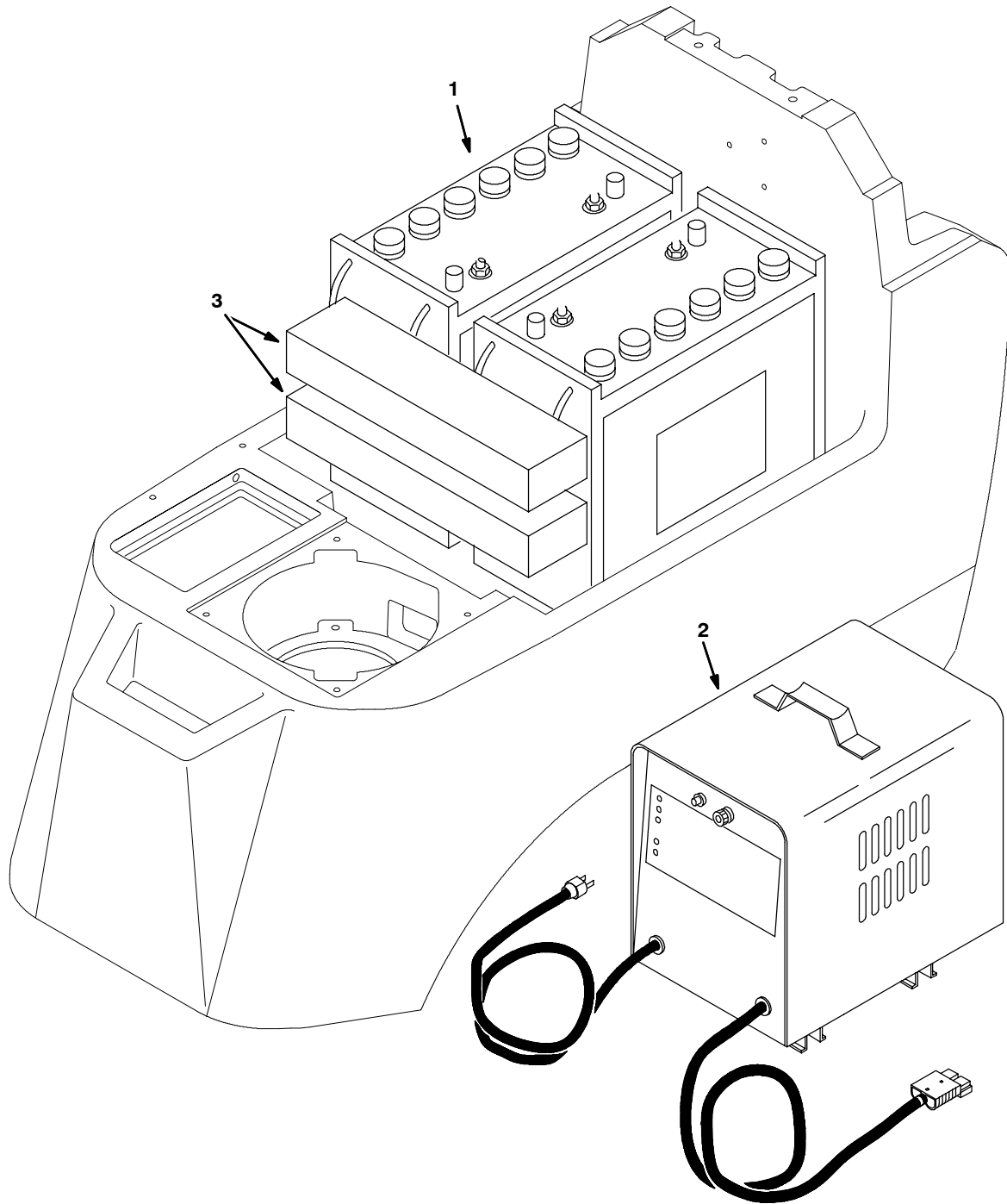

REF	PART #	DESCRIPTION	QTY.
1	130869	●BATTERY, 12V 130AH (WET)	2
	600394	BATTERY, 12V 215AH (WET)	2

● RECOMMENDED STOCK ITEMS

REF	PART #	DESCRIPTION	QTY.
2	603553	●CHARGER 24DC/12A 120V DUAL-MODE (FOR 130AH BATTERIES)	1
	603235	CHARGER 24DC/20A/120AC RED-PLUG (FOR 215AH BATTERIES)	1
3	630375	STOP, BATTERY INSERT	3

BATTERY CABLE GROUP

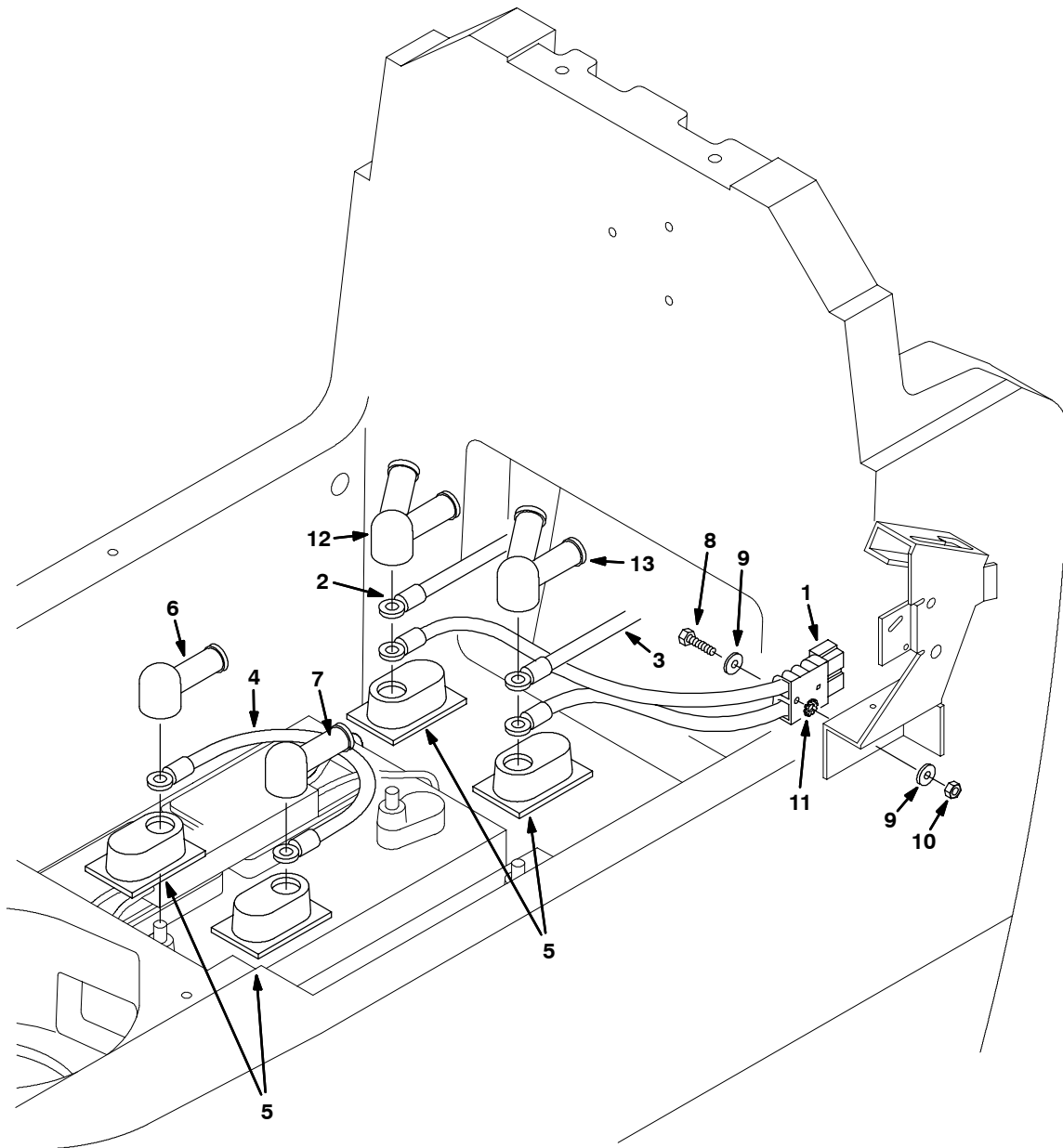

REF	PART #	DESCRIPTION	QTY.
1	630118	CABLE, BATTERY, W/CHARGE PLUG, RED	1
2	630110	CABLE, BATTERY, 4GA, RED	1
3	630111	CABLE, BATTERY, 4GA, BLK	1
4	603061	CABLE, BATTERY 6GA, RED	1
5	45962	CAP, PLSTC, .04 1.38X2.30 0.5L	4
6	611221	BOOT, CABLE, BATTERY TERMINAL, BLACK	1
7	611222	BOOT, CABLE, BATTERY TERMINAL, RED	1

REF	PART #	DESCRIPTION	QTY.
8	200051274	SCREW, M3X30MM	2
9	601127000	WASHER, FLAT, 3.7 8.0, .5	4
10	579211	NUT, HEX, LOCK, M3	2
11	140019	WASHER, EXT. LOCK #6	2
12	606011	BOOT, INSULATING CABLE, RED	1
13	606010	BOOT, INSULATING CABLE, BLACK	1

# PARTS LIST

## ELECTRIC MOTOR BREAKDOWN

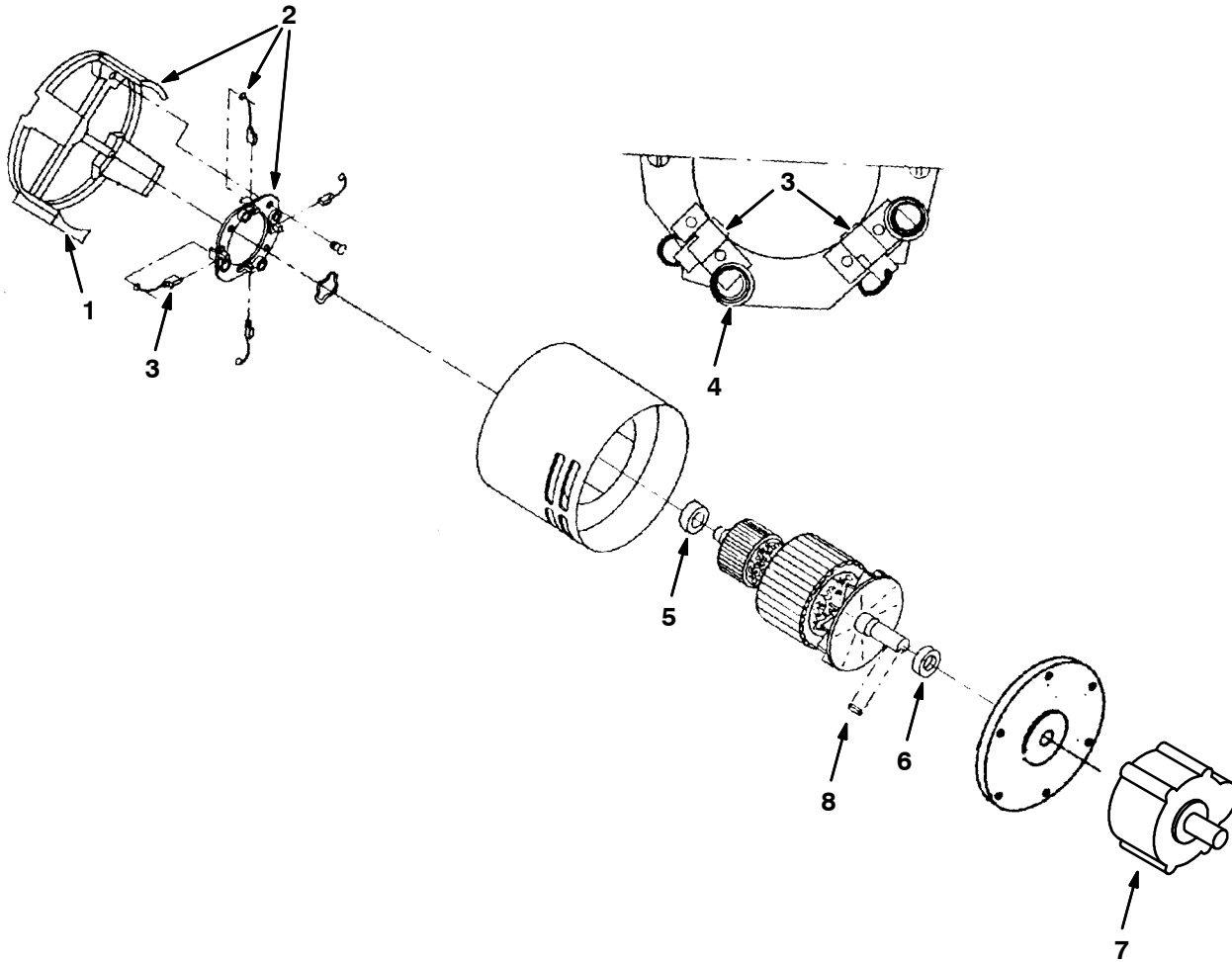

REF	PART #	DESCRIPTION	QTY.
∇	605054	MOTOR, .75HP 270RPM 24VDC	1
▲ 1	630612	STRAIN RELIEF	2
▲∇ 2	630608	COMMUTATOR BRACKET ASSY (INCLUDING BRUSH BOARD ASSY)	1
▲▲ 3	190970	BRUSH ASSEMBLY	4
▲▲ 4	602131000	BRUSH SPRING	4

REF	PART #	DESCRIPTION	QTY.
▲ 5	602088000	BEARING	1
▲ 6	630607	BEARING	1
▲ 7	374005	GEARBOX ASSEMBLY	1
▲ 8	630454	KEY, 1/4X1/4X1-1/8	1

∇ ASSEMBLY

▲ INCLUDED IN ASSEMBLY

WET PICK-UP TOOL KIT

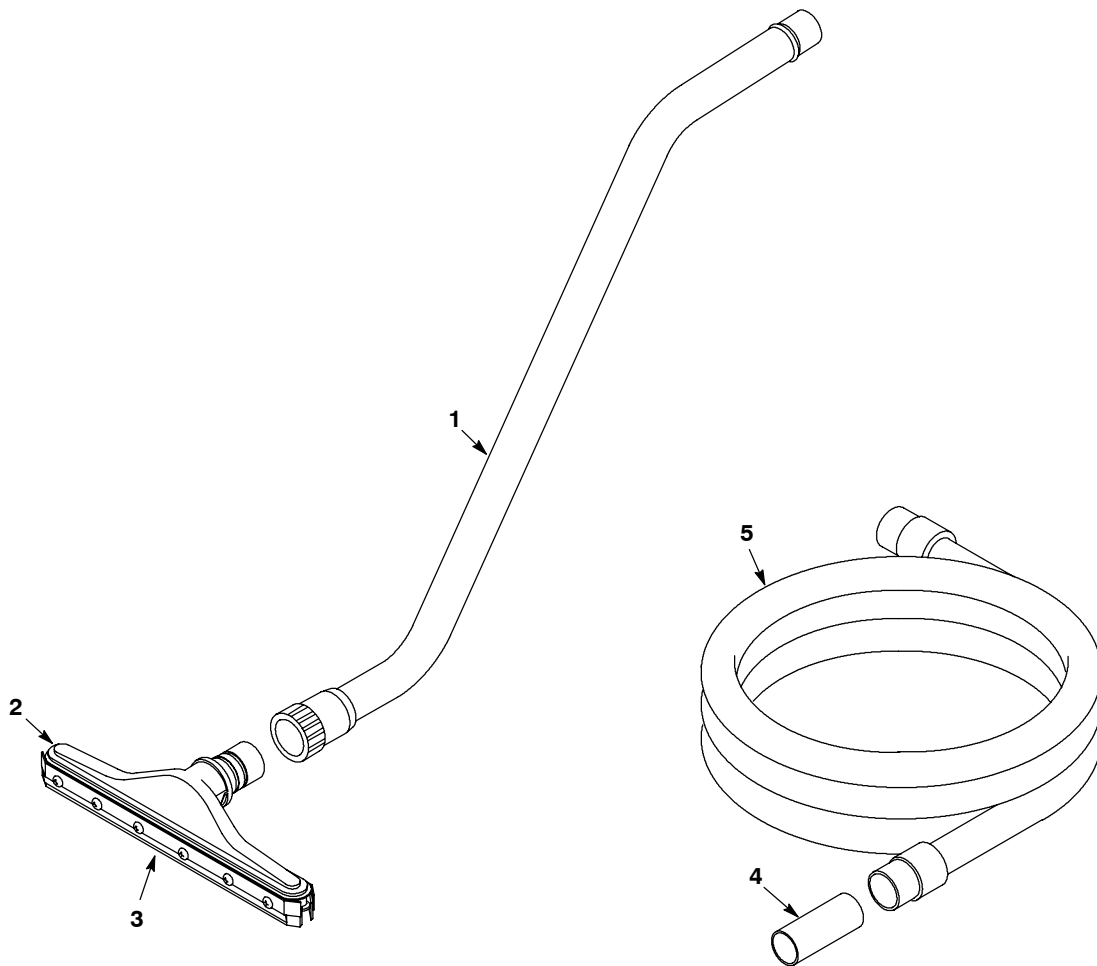

REF	PART #	DESCRIPTION	QTY.
▽	190928	●KIT, WET PICK-UP TOOL	1
▲▽ 1	6108.1	WAND, TWO BEND ALUMINUM	1
▲	605257	RING, LOCK BRASS	1
▲	600828	NUT, WAND COUPLING	1
▲▽ 2	13840	●TOOL, SQUEEGEE PUSH/PULL 355MM (14 IN.)	1
▲ 3	605137	●BLADES, REPLACEMENT (SET/4)	1

REF	PART #	DESCRIPTION	QTY.
▲ 4	160451	●CONNECTOR, 1-1/2 VAC HOSE	1
▲ 5	160481	●HOSE, VAC 1-1/2X3M (10 FT.)	1

▽ ASSEMBLY

▲ INCLUDED IN ASSEMBLY

● RECOMMENDED STOCK ITEMS

NON-POWER WAND ASSEMBLY

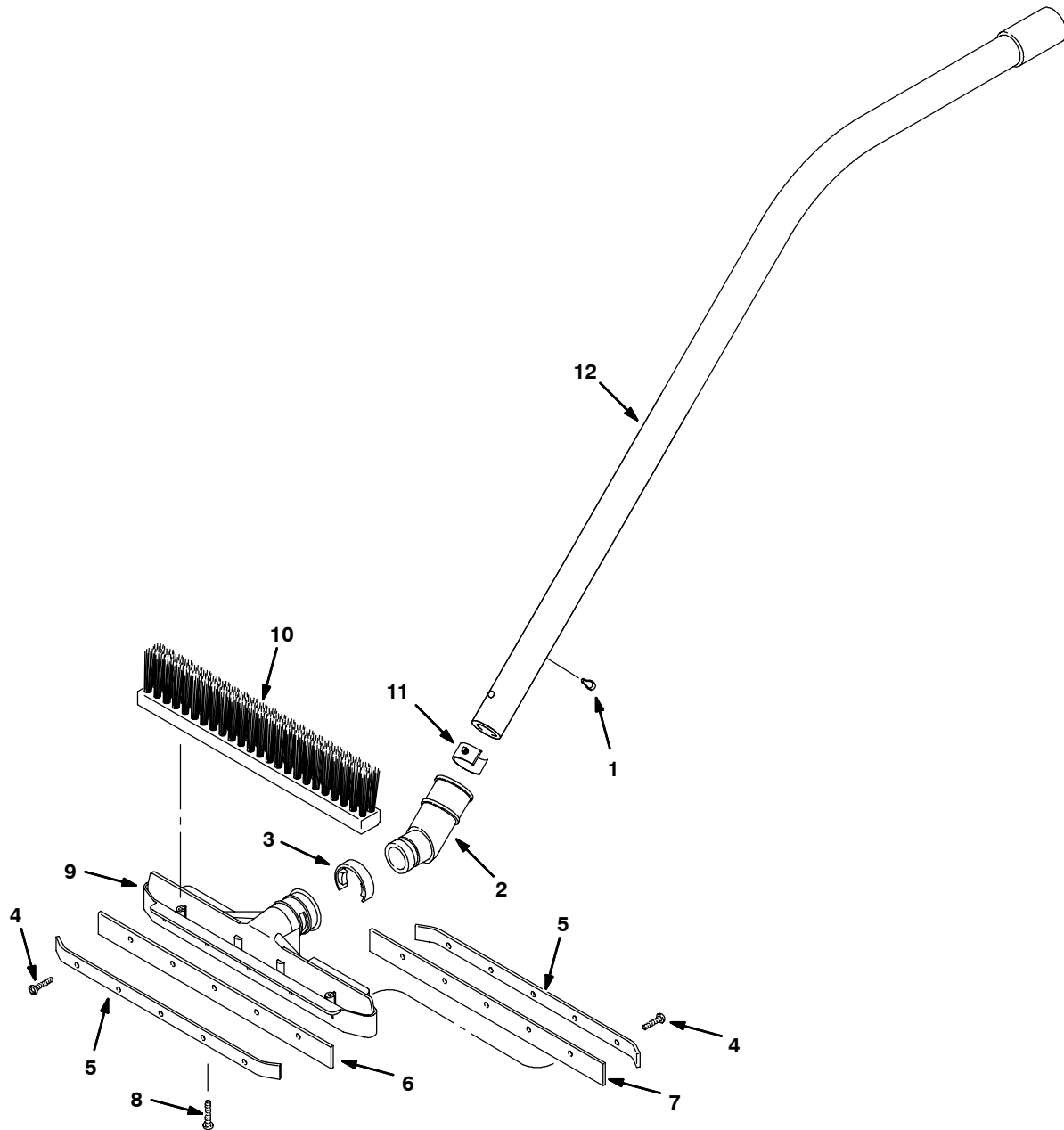

REF	PART #	DESCRIPTION	QTY.
∇	630732	●WAND ASM., NON-POWER	1
▲ 1	630269	BUMPER, MUSHROOM	2
▲ 2	579113	SWIVEL, WAND ATTACHMENT	1
▲ 3	579132	RING, ATTACHMENT	1
▲ 4	579135	SCREW, SELF TD UNITED	10
▲ 5	579103	RETAINER, WAND BLADE	2

REF	PART #	DESCRIPTION	QTY.
▲ 6	579239	●BLADE, SQUEEGEE, FRONT	1
▲ 7	579230	●BLADE, SQUEEGEE, REAR	1
▲ 8	579147	SCREW, #6X1-1/2 SELF TAP	2
▲ 9	579101	HEAD, WAND	1
▲ 10	579102	●BRUSH, WAND (TWO ROW)	1
▲ 11	579187	CLIP, SPRING	1
▲ 12	579109	WAND, SINGLE BEND	1

∇ ASSEMBLY

▲ INCLUDED IN ASSEMBLY

● RECOMMENDED STOCK ITEMS

POWER WAND ASSEMBLY

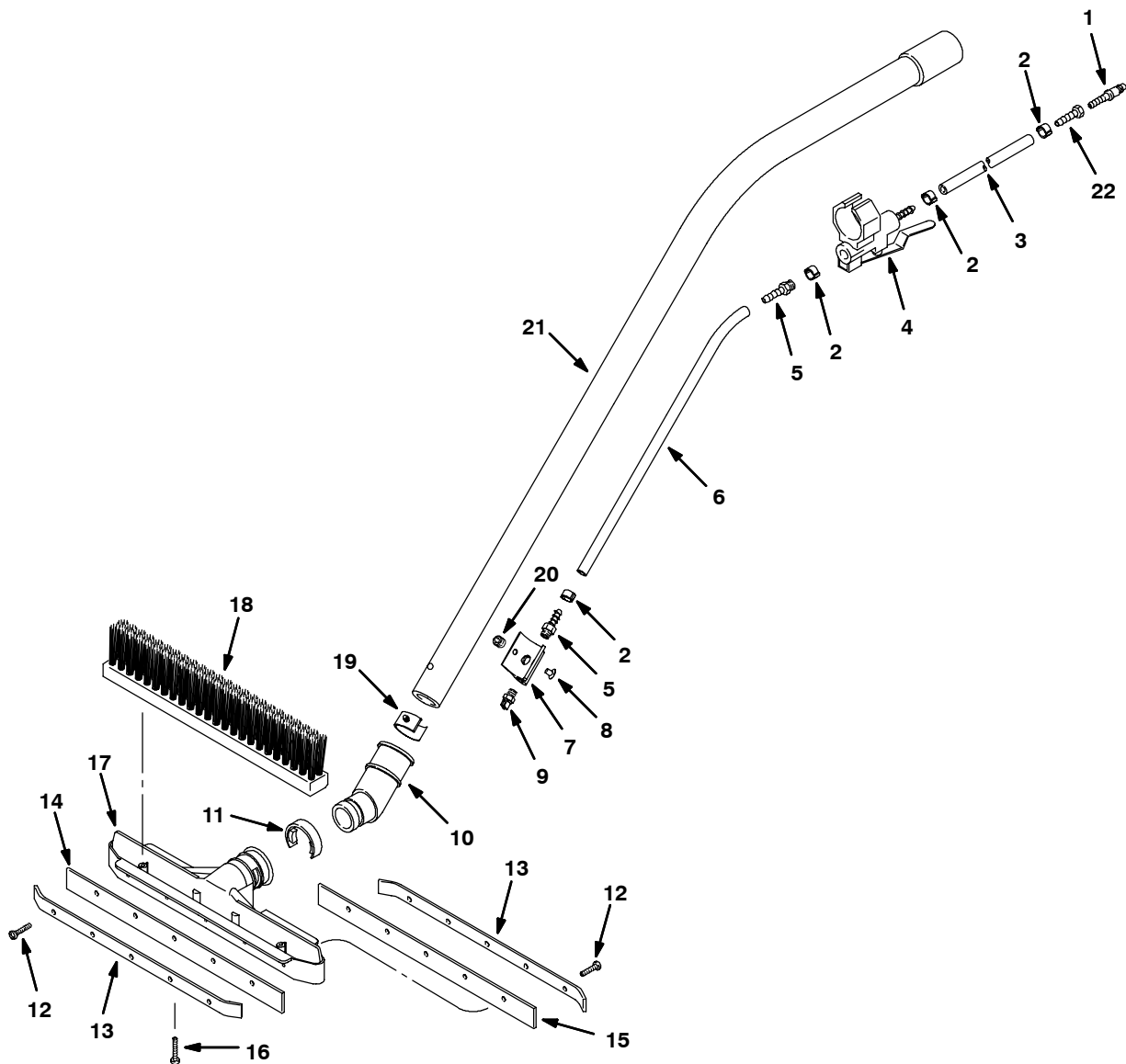

REF	PART #	DESCRIPTION	QTY.
▽	579908	●WAND ASM., POWER	1
▲ 1	578091000	FITTING, 1/4M QD CPLR	1
▲ 2	578160000	CLAMP, HOSE, 11-13MM	4
▲ 3	613536	●HOSE, 1/4ID X .400M	1
▲ 4	579107	●VALVE, WATER CONT.	1
▲ 5	150525	FITTING, 1/8M X 1/4H BARB	2
▲ 6	613537	●HOSE, 1/4ID X 1.083M	1
▲ 7	579112	FITTING, SPRAY NOZZLE ADAPTER	1
▲ 8	579198	RIVET, POP	2
▲ 9	579137	●FITTING, TIP, 9508 1/8V JET	1
▲ 10	579113	SWIVEL, WAND ATTACHMENT	1

REF	PART #	DESCRIPTION	QTY.
▲ 11	579132	RING, ATTACHMENT	1
▲ 12	579135	SCREW, SELF TD UNITED	10
▲ 13	579103	RETAINER, WAND BLADE	2
▲ 14	579239	●BLADE, SQUEEGEE, FRONT	1
▲ 15	579230	●BLADE, SQUEEGEE, REAR	1
▲ 16	579147	SCREW, #6X1-1/2 SELF TAP	2
▲ 17	579101	HEAD, WAND	1
▲ 18	579102	●BRUSH, WAND (TWO ROW)	1
▲ 19	579187	CLIP, SPRING	1
▲ 20	150208	FITTING, 1/8M PLUG	1
▲ 21	579109	WAND, SINGLE BEND	1
▲ 22	150510	FITTING, 1/4F X 1/4H BARB	1

▽ ASSEMBLY

▲ INCLUDED IN ASSEMBLY

● RECOMMENDED STOCK ITEMS

DELUXE POWER WAND ASSEMBLY

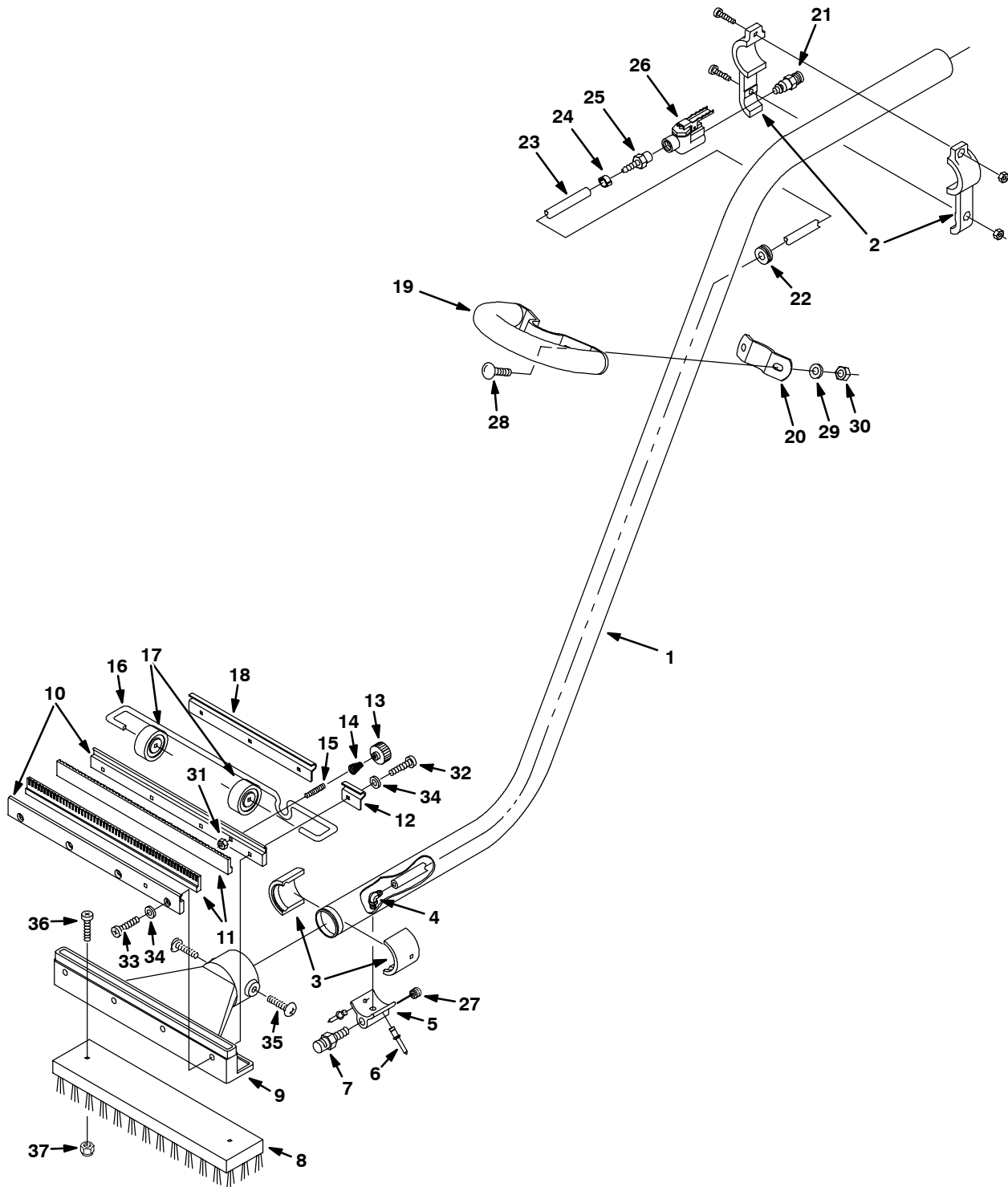

**DELUXE POWER WAND ASSEMBLY**

REF	PART #	DESCRIPTION	QTY.
▽	578905000	●WAND ASM., DELUXE, POWER	1
▲ 1	578060000	WAND, DOUBLE BEND	1
▲ 2	578077000	BRACKET, VALVE MOUNTING	1
▲ 3	578061000	ADAPTER, HEAD/WAND	2
▲ 4	578214000	FITTING, 1/8MX1/4H ELBOW 90	1
▲ 5	579112	FITTING, SPRAY NOZZLE ADAPTER	1
▲ 6	579198	RIVET, POP	2
▲ 7	578066000	●FITTING TIP 75, 1/8K JET	1
▲ 8	578073000	●BRUSH, DECK, POLYPRO BLOCK	1
▲ 9	578063000	HEAD, WAND	1
▲ 10	578078000	RETAINER, SQUEEGEE WAND	2
▲ 11	578074000	●BLADE, SQUEEGEE WAND	2
▲ 12	578124000	BRACKET, AXLE	1
▲ 13	578439	NUT, M6X1.0 THUMB	1
▲ 14	613732	SPRING, COMP, CONICAL	1
▲ 15	578143000	SCREW, M6X1.0X40 SET	1
▲ 16	578126000	AXLE, WAND	1
▲ 17	578125000	●WHEEL, GUIDE, WAND	2
▲ 18	578123000	BRACKET, AXLE	1

REF	PART #	DESCRIPTION	QTY.
▲ 19	578155000	WELDMENT, HANDLE	1
▲ 20	578154000	BRACKET, HANDLE	1
▲ 21	578091000	●FITTING, 1/4M QD CPLR	1
▲ 22	578164000	GROMMET	1
▲ 23	578821000	●HOSE, 1/4ID X 1.220M	1
▲ 24	578161000	CLAMP, HOSE 8-11MM	1
▲ 25	578094000	FITTING, 1/4H X 1/4NPT BARB	1
▲ 26	578064000	●VALVE, WATER CONTROL	1
▲ 27	150208	FITTING, 1/8M PLUG	1
▲ 28	20399	BOLT, 1/4-20X0.75 CARRIAGE	2
▲ 29	200304017	WASHER, M6.4 FLAT	2
▲ 30	41169	NUT, 1/4-20 HXLCK	2
▲ 31	07785	NUT, M06X1.0 HEX	1
▲ 32	578144000	SCREW, M5X0.8X16 PANPHL	4
▲ 33	578141000	SCREW, M5X0.8X10 PANPHL	4
▲ 34	140018	WASHER, #10 LOCK	8
▲ 35	140885	SCREW, 1/4-20X1/2 TRSPHL	2
▲ 36	578566	SCREW, M4X30 FLTPHL	2
▲ 37	140288	NUT, M4X0.7 NYLCK	2

▽ ASSEMBLY

▲ INCLUDED IN ASSEMBLY

● RECOMMENDED STOCK ITEMS

**NON-POWER WAND HOSE ASSEMBLY**

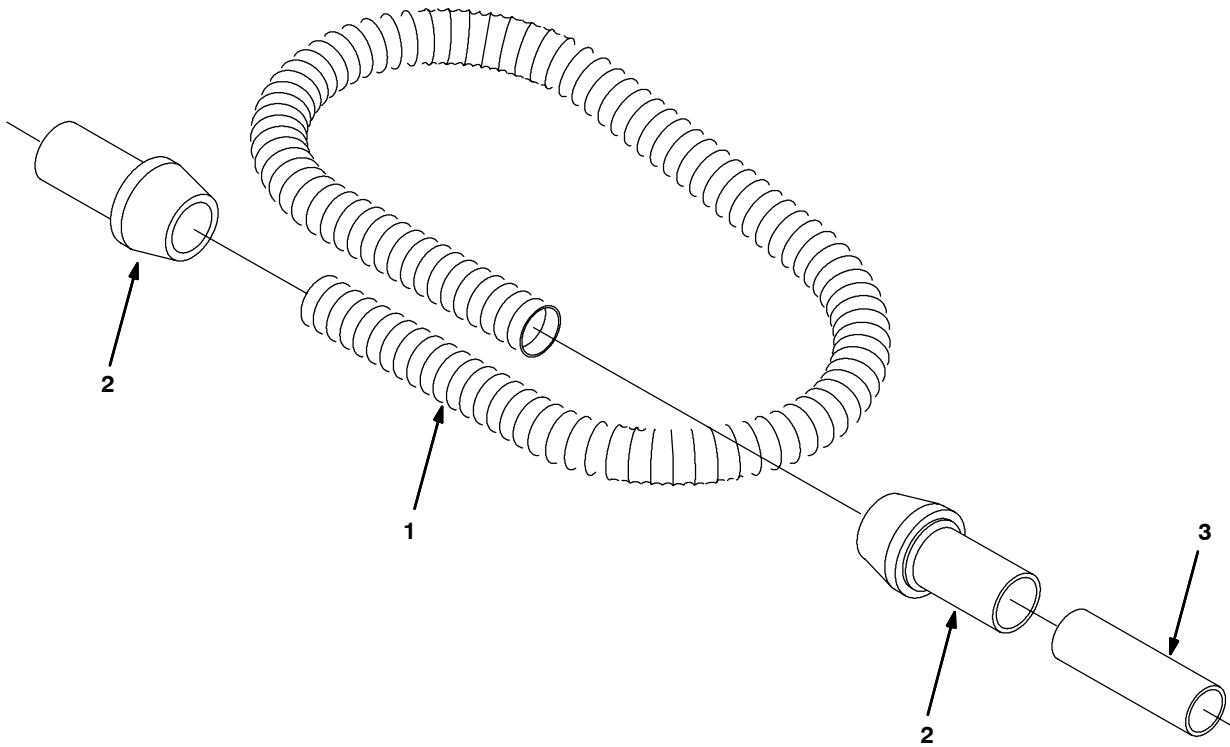

REF	PART #	DESCRIPTION	QTY.
▽	630739	●HOSE ASM., NON-POWER WAND	1
▲ 1	578276000	●HOSE, VACUUM, 1.5DX10'L GRAY	1

REF	PART #	DESCRIPTION	QTY.
▲ 2	630449	●CUFF, HOSE, 1.50 SOFT	2
▲ 3	231031	TUBE, 1.50DX5.0L	1

▽ ASSEMBLY

▲ INCLUDED IN ASSEMBLY

● RECOMMENDED STOCK ITEMS

POWER WAND HOSE ASSEMBLY

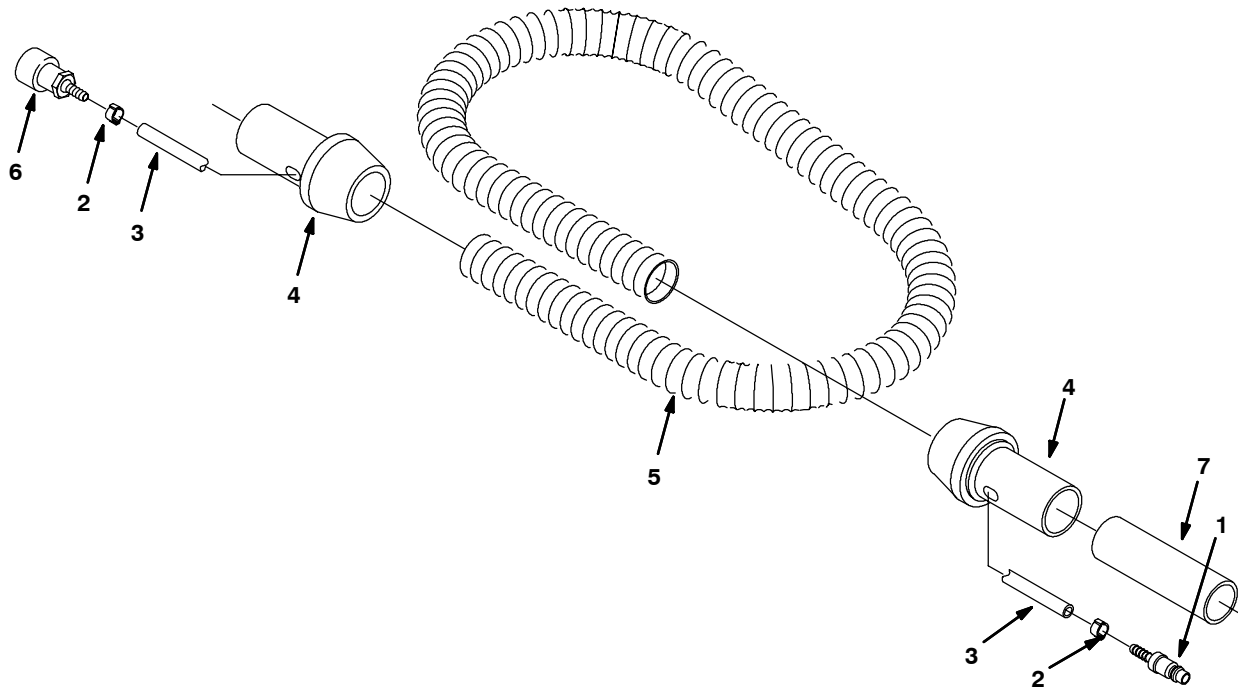

REF	PART #	DESCRIPTION	QTY.
▽	578903000	●HOSE ASM., POWER WAND	1
▲ 1	578318000	●FITTING, STL, QDC, PM06/BM04	1
▲ 2	140325	CLAMP, HOSE, EAR, 0.50D	2
▲ 3	578820000	●HOSE, .25ID, .44OD, (578227000) 4.0M LG	1

REF	PART #	DESCRIPTION	QTY.
▲ 4	578072000	●CUFF, SWIVEL, 1-1/2 BLACK	2
▲ 5	578276000	●HOSE, VACUUM, 1.5DX10'L GRAY	1
▲ 6	578071000	●CONNECTOR, BRS, QDC, PF04/BM04	1
▲ 7	231031	TUBE, 1.50DX5.0L	1

▽ ASSEMBLY

▲ INCLUDED IN ASSEMBLY

● RECOMMENDED STOCK ITEMS



ACCESSORY CONSOLE GROUP

REF	PART #	DESCRIPTION	QTY.
	607486	●KIT, KEY SWITCH/ HOUR METER	1
	607487	●KIT, ES/KEY SWITCH/ HOUR METER	1
	607488	●KIT, ES/KEY SWITCH/ HOUR METER/WAND PUMP	1
	607489	●KIT, WAND PUMP	1
	607490	●KIT, KEY SWITCH/HOUR METER/WAND PUMP	1
	607491	●KIT, KEY SWITCH/ HOUR METER/AUTO STOP BUTTON	1
	607492	●KIT, ES/KEY SWITCH/ HOUR METER/AUTO STOP BUTTON	1
	607493	●KIT, ES/WAND PUMP/ KEY SWITCH/HOUR METER/AUTO STOP BUTTON	1
	607494	●KIT, WAND PUMP/ KEY SWITCH/HOUR METER/AUTO STOP BUTTON	1
1	630140	CONSOLE, 20" SCRUBBER	1
2	630331	WIRE ASSY, KEY SWITCH	1
3	200070354	SCREW, M4X0.7X30 PANPHL	2
4	140287	SCREW, M4X0.7X16 PANPHL	2
5	02938	WASHER, LOCK, INT, 08, SS	4
6	578852	RIVET, SNAP, 5.0MM DIA.	1
7	1010555	●METER, HOUR, 18-60VDC	1
8	630142	●LIGHT, PILOT, 24V, BLUE	1
9	630145	●TIMER, 24VDC, RANGE: 30SEC	1
10	630419	●SWITCH, RCKR, SPST, 24VDC, GREEN	2

● RECOMMENDED STOCK ITEMS

REF	PART #	DESCRIPTION	QTY.
11	607475	●SWITCH, KEYLOCK 12-AMP	1
12	607821	●KEY, REPLACEMENT, STEEL	1
13	630237	DECAL, ES/KEY/HR/LIGHT/WP	1
	630236	DECAL, ES/KEY/HR MTR/LIGHT	1
	630238	DECAL, WAND PUMP	1
	630239	DECAL, KEY/HR/W. PUMP	1
	630235	DECAL, KEY/HOUR METER	1
14	630334	SCREW, #6X1-3/8 SELF TAP	1
15	606499	HARNESS, WIRE ES OPTION	1
16	630342	HARNESS, WIRE ES	1
17	606502	HARNESS, ACCESSORY	1
18	630097	●SWITCH, CONTACT	1
19	630100	●BUTTON, SWITCH, EMERG. STOP	1
20	630266	WIRE ASSY	1
21	578720	●SPLASH GUARD, ROCKER SWITCH	2
22	601271	SCREW, M4X0.7X25 STUD	2
23	02938	WASHER, LOCK, INT, 08, SS	2
24	140026	WASHER, #6 FLAT	1
25	200102014	NUT, M4 X .7 HEX	2
26	630442	●SEAL, O-RING, 540MM LG.	1
27	140018	WASHER, #10 LOCK	1
28	1021166	SPACER, HOUR METER, HOBBS	1

WAND PUMP PLUMBING GROUP

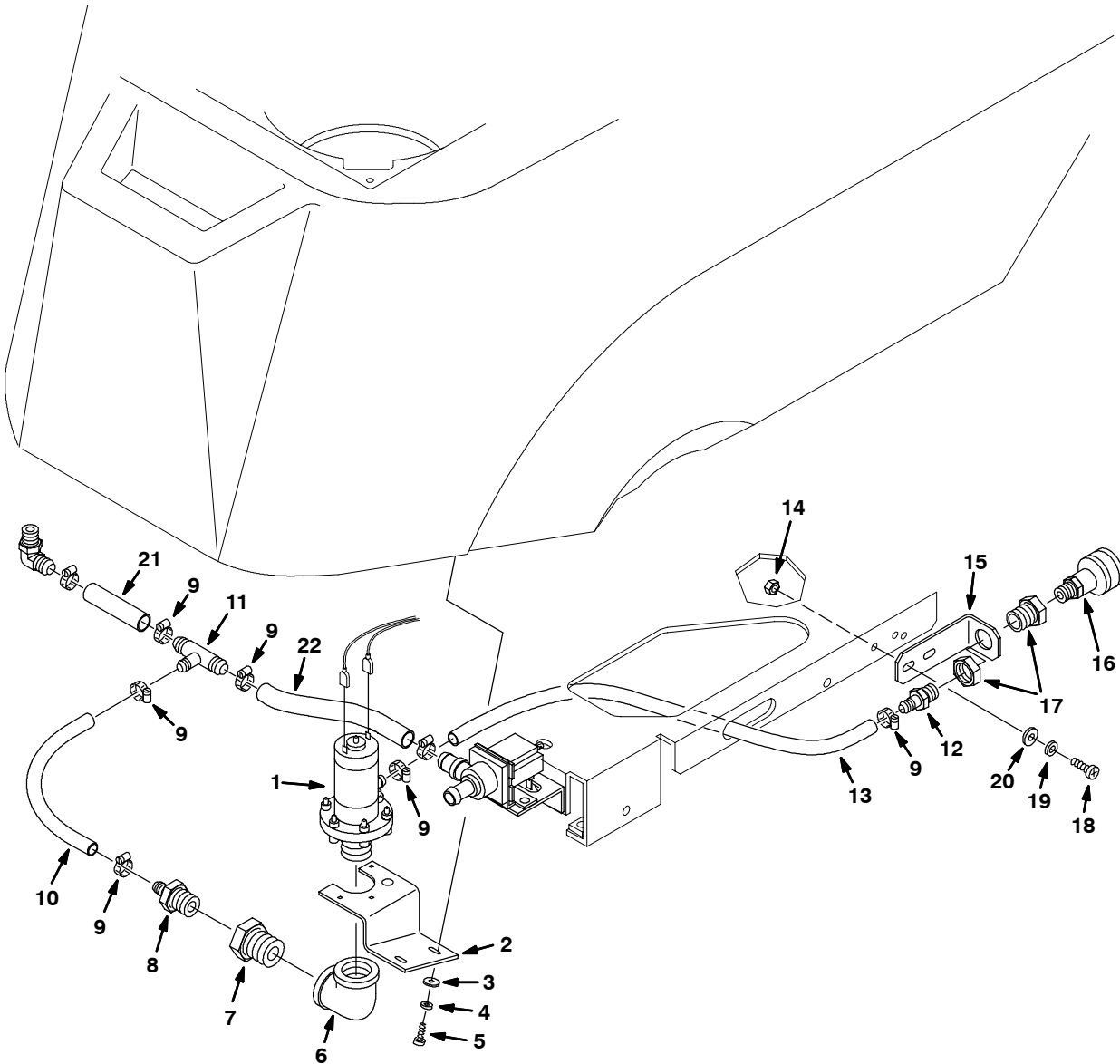

REF	PART #	DESCRIPTION	QTY.
1	630136	●PUMP, SOLUTION, 24VDC	1
2	630335	BRACKET, MTG, PUMP	1
3	200315016	WASHER, M5.3 FLAT	2
4	140018	WASHER, #10 LOCK	2
5	200070384	SCREW, M5X0.8X14 PANPHL	2
6	630251	FITTING, E90 PF12/PF12	1
7	630252	FITTING, 3/4MX3/8F BUSHING	1
8	150538	FITTING, 3/8MX3/8H BARB	1
9	54333	CLAMP, HOSE 5/16-7/8	6
10	630417	●HOSE, 3/8IDX.541 FT.	1
11	630372	FITTING, TEE, BM08/BM06/BM08	1

● RECOMMENDED STOCK ITEMS

REF	PART #	DESCRIPTION	QTY.
12	150516	FITTING, STR, 04PM/06BM	1
13	630418	●HOSE, 27.5" OF 376720	2,300 FT.
14	579029	NUT, M6X1.0	2
15	630256	BRACKET, MTG. QUICK CON.	1
16	608292	●FITTING, QUICK DISC FEMALE 3/8X1/4 NPT	1
17	150300	FITTING, STR PF04/PF04	1
18	608322	SCREW, M6X1.0X16 TRSPHL	2
19	578244000	WASHER, M6.4 LOCK	2
20	579210	WASHER, M6.4 FLAT	2
21	613511	●HOSE, 1/2IDX3/4OD VINYL 611259 FT. 0.212	0.212 FT.
22	613518	●HOSE, 1/2IDX3/4OD VINYL 611259 FT. 0.670	0.670 FT.

ES (EXTENDED SCRUB) PLUMBING GROUP

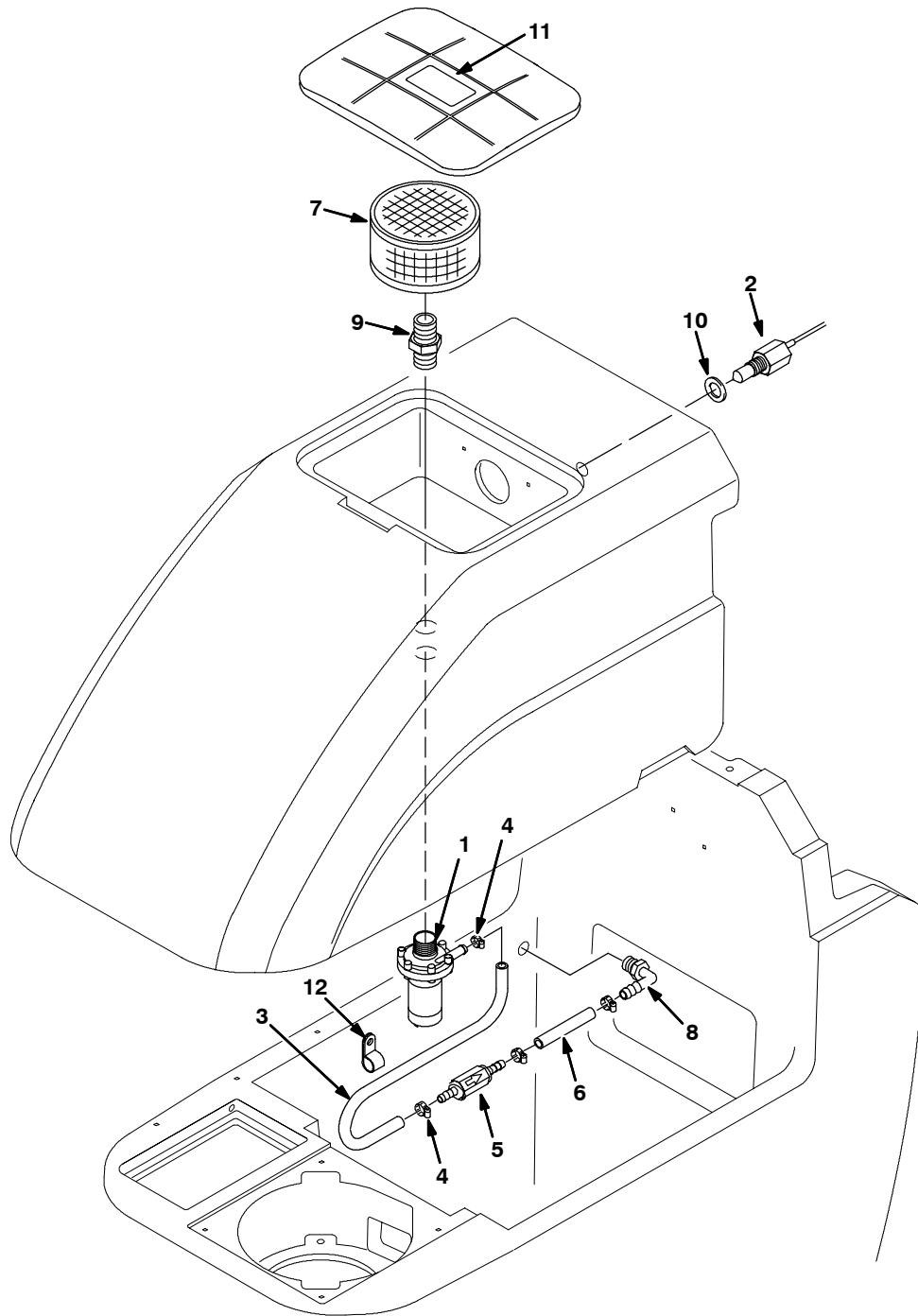

REF	PART #	DESCRIPTION	QTY.
1	630136	●PUMP, SOLENOID, 24VDC	1
2	630137	●SENSOR, WATER LEVEL	1
3	606325	●HOSE, 3/8IDX5/8OD 376720 BULK HOSE	2.000 FT.
4	54333	CLAMP, HOSE 5/16-7/8	4
5	210044	●VALVE, CHECK, 06BM/06BM	1
6	630438	●HOSE, 3/8IDX5/8OD 376720 BULK HOSE	0.470 FT.

REF	PART #	DESCRIPTION	QTY.
7	630138	●FILTER, SCREEN, 100-MESH	1
8	150412	FITTING, E90 PM06/BM06	1
9	630385	FITTING, STR PM12/PM12	1
10	630479	WASHER, M17 FLAT NYLON	1
11	630440	DECAL, DO NOT REMOVE FILTER	1
12	140314	CLAMP, INSULATED 3/4ID	1

● RECOMMENDED STOCK ITEMS

SOUND KIT

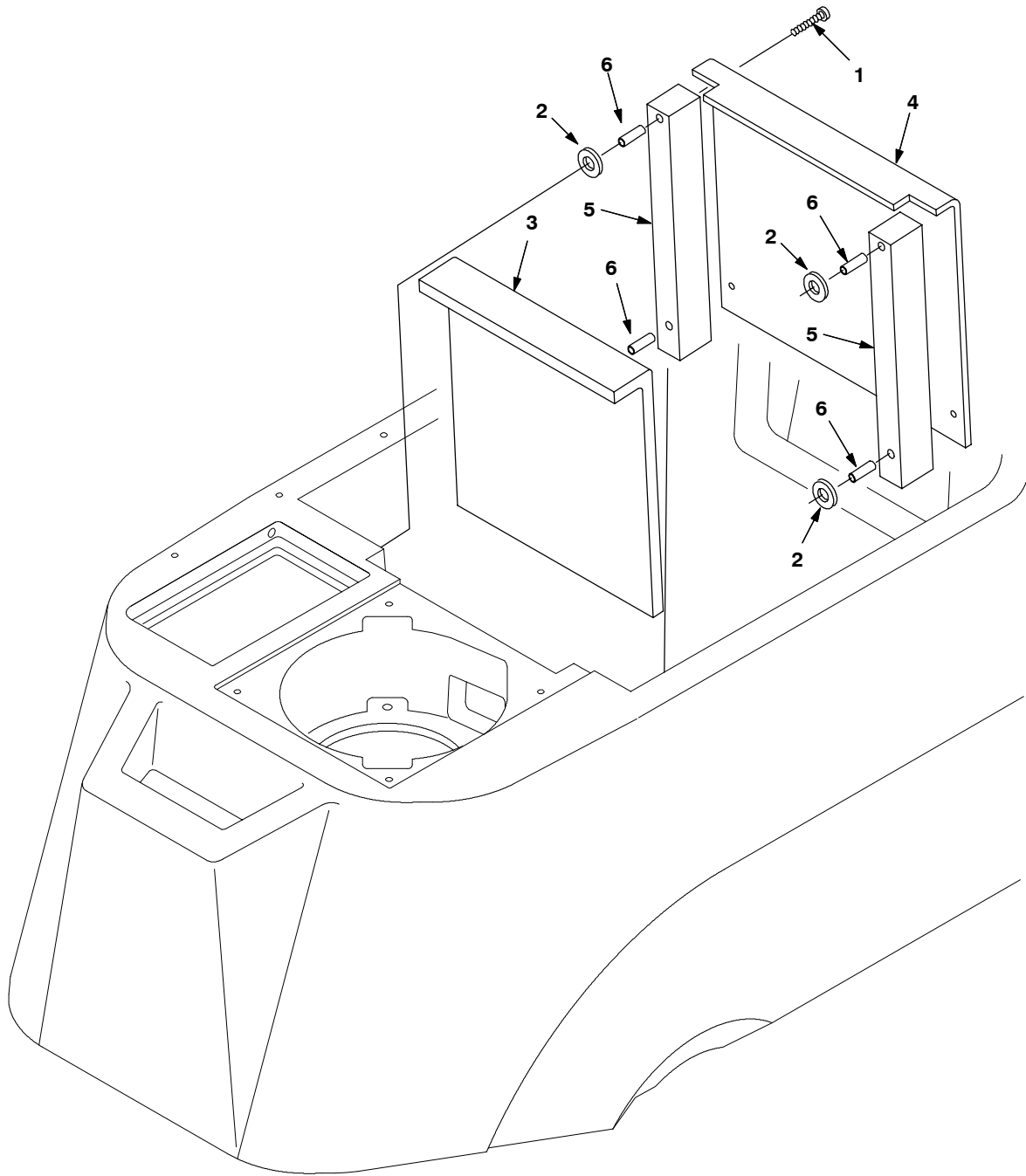

REF	PART #	DESCRIPTION	QTY.
▽	630735	●KIT, SOUND LOW DB	1
▲ 1	600393	SCREW, M5X0.8X40 FLTHD	4
▲ 2	200315016	WASHER, M5.3 FLAT	4
▲ 3	630441	●SOUND COVER, FOAM	1

REF	PART #	DESCRIPTION	QTY.
▲ 4	630395	PLATE, COVER, SOUND	1
▲ 5	630397	●INSULATION, COVER, SIDE	2
▲ 6	630398	SLEEVE, .315D .217B .98L	4

▽ ASSEMBLY

▲ INCLUDED IN ASSEMBLY

● RECOMMENDED STOCK ITEMS