



Electronic Service Manuals

This electronic document is provided as a service to our customers. We do not create the contents of the information contained in this document. Should you have detailed questions pertaining to the information contained in this document, you may contact Michco, or the manufacturer which provided the original information in this electronic deliverable. Michco's only part in this electronic deliverable was the electronic assembly process.

You may contact Michco through the following methods:
Phone (517) 484-9312 or (800) 331-3339 MI, OH, IN only
2011 N. High St. -- Lansing, Michigan -- 48906
Fax: (517) 484-9836
Email: CustServ@Michco.com
Web site: www.Michco.Com
Parts Web site: www.FloorMachineParts.Com

Order Parts on Line at:
www.FloorMachineParts.Com

Directly to Parts & Service:
By Email: **Shop@Michco.com**
By Fax: (517) 702-2041
By Voice: Use numbers above.

Serving the Cleaning Industry Since 1922

Notice: All copyrighted material remains property of original owners, all trademarks are property of respective owners. Manuals are subject to Manufacturer's reproduction limitations. Originals or reproductions were provided by manufacturers through a request. We make no warranty as to the correctness of information provided in this document and you assume all risk.

GENIUS 14

GENIUS 18

INTRODUCTION

OPERATING & MAINTENANCE INSTRUCTIONS

READ THIS BOOK

This operator's book has important information for the use and safe operation of this machine. Read this book carefully before starting the machine. Keep this book and tell all operators to read the book. If you do not follow the instructions, you can cause an injury or damage equipment, furniture or buildings.

For new books write to:

Pacific
2259 S. Sheridan
Muskegon, MI 49442-6252

Carefully inspect all components to ensure that there is no concealed freight damage. If such damage is discovered, file a "CONCEALED DAMAGE REPORT" immediately with the delivering carrier.

The contents of this manual are based on the latest product information available at the time of publication. Pacific reserves the right to make changes or improvements to its machines without notice.

FOR YOUR CONVENIENCE, RECORD THE FOLLOWING INFORMATION:

MODEL _____

SERIAL NUMBER _____

PART NUMBER _____

DATE PURCHASED _____

IMPORTANT SAFETY INSTRUCTIONS

READ AND UNDERSTAND ALL WARNINGS AND INSTRUCTIONS BEFORE USING THIS APPLIANCE!

WARNING! To reduce the risk of fire, electric shock, or injury:

1. Do not leave appliance when plugged in. Unplug from outlet when not in use and before servicing.
2. Do not use outdoors or on wet surfaces.
3. Do not allow to be used as a toy. Close attention is necessary when used by or near children.
4. Use only as described in this manual. Use only manufacturer's attachments.
5. Do not use with damaged cord or plug. If appliance should not work as it should, has been dropped or damaged, left outdoors, or dropped into water, return it to service center.
6. Do not pull or carry by cord, use cord as handle, close a door on cord or pull cord around sharp edges or corners. Do not run appliance over cord. Keep cord away from heated surfaces.
7. Do not unplug by pulling on cord. To unplug, grasp the plug, not the cord
8. Do not handle plug or appliance with wet hands.
9. Do not put any objects into opening. Do not use with any opening blocked: keep free of dust, lint, hair and anything that may reduce airflow.
10. Keep hair, loose clothing, fingers and all parts of the body away from openings and moving parts.
11. Turn off all controls before unplugging.
12. Use extra care when cleaning on stairs.
13. Do not use to pick up flammable or combustible liquids such as gasoline or use in areas where they may be present.
14. Connect to a properly grounded outlet only.
15. Do not pick up anything that is burning or smoking, such as cigarettes, matches or hot ashes.
16. Do not use without dust bag and/or filters in place.

Grounding Instructions

This machine must be grounded. If it should malfunction or break down, grounding provides a path of least resistance for electric current to reduce the risk of electric shock. This machine is equipped with a cord having an equipment-grounding conductor and grounding plug. The plug must be inserted into an appropriate outlet that is properly installed and grounded in accordance with all local codes and ordinances.

WARNING - Improper connection of the equipment-grounding conductor can result in a risk of electric shock. Check with a qualified electrician or service person if you are in doubt as to whether the outlet is properly grounded. Do not modify the plug provided with the machine - if it will not fit the outlet, have a proper outlet installed by a qualified electrician.

This machine is for use on a nominal 120-volt circuit, and has a grounded plug that looks like the plug illustrated in figure A. A temporary adapter that looks like the adapter illustrated in figures B and C may be used to connect this plug to a 2-pole receptacle as shown in figure B if a properly grounded outlet is not available. The temporary adapter should be used only until a properly grounded outlet (figure A) can be installed by a qualified electrician. The green colored rigid ear, lug, or the like extending from the adapter must be connected to a permanent ground such as a properly grounded outlet box cover. Whenever the adapter is used, it must be held in place by a metal screw.

NOTE: In Canada, the use of a temporary adapter is not permitted by the Canadian Electrical Code

EXTENSION CORDS

Use only three-wire 16/3 or larger gauge approved extension cords that have three-prong grounding type plugs and three-pole receptacles that accept the appliance's plug. Replace or repair any damaged cords or plugs.

When servicing, refer to authorized person only. Use only identical replacement parts.

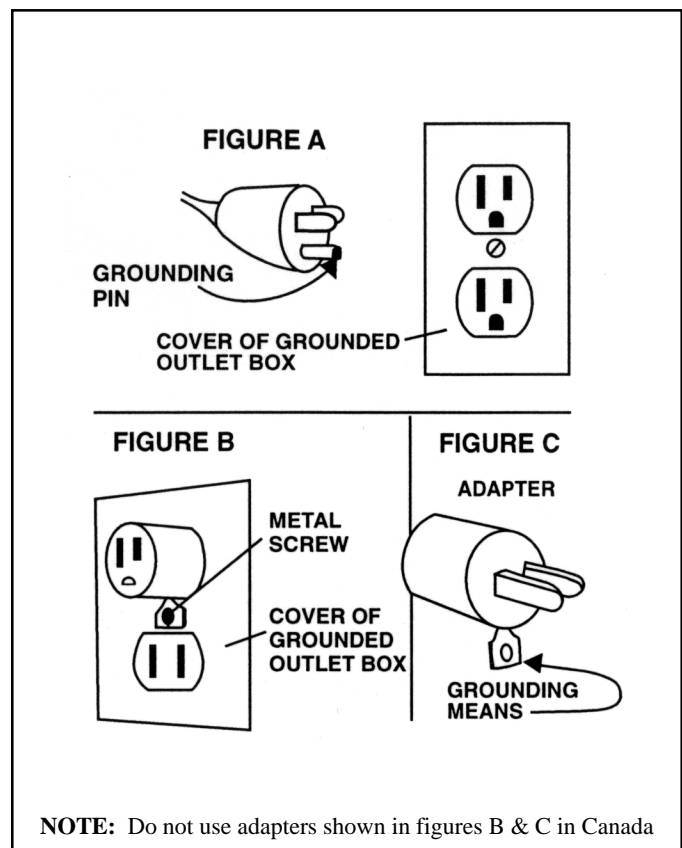

OPERATING PROCEDURES

WARNING! For the safe operation of this machine follow the instructions given in this booklet and the training given by your supervisor. Failure to do so can result in personal injury and/or damage to machine and property!

DO NOT OPERATE MACHINE IN AN EXPLOSIVE ENVIRONMENT!

WARNING! NEVER USE THIS MACHINE TO PICK UP VOLATILE OR EXPLOSIVE MATERIALS.

WARNING! DO NOT PICK UP WET MATERIAL WITH THIS MACHINE.

The model shown in this manual is intended for commercial use and for vacuuming dry material only.

ASSEMBLY

To prepare the machine for operation, make sure it is of correct voltage and properly assembled. If in doubt, ask your supervisor.

1. Place the brush head on a flat surface and latch the swivel neck into the upright and locked position.
2. Turn the knob (Drawing 1, Item 57) located on tank assembly counterclockwise to the right. Insert the tank assembly over the projection ears on the lower unit while keeping the tank in the vertical position. Return the knob to the locked position by turning it clockwise.
3. Attach the flexible hose to the vacuum tank. The long rigid portion of the flexible hose should be inserted into the lower portion of the vacuum tank assembly.

OPERATION AS AN UPRIGHT VACUUM

1. **Properly install the filter bag in the vacuum:** Depress the two white buttons on the back of the vacuum housing door (Drawing 1, Item 8), then swing it up and open. Place the bag into the opening with the notched portion next to the handle tube.
2. **Plug the machine's power cable into a properly grounded outlet** (see Safety Instructions).
3. **Adjust the brush height** to suit the thickness of the carpet. The adjustment ranges from positions 1 through 4: Position 1 for very low pile carpet and Position 4 for very high pile carpet. Adjust the height adjustment knob (Drawing 2, Item 39) to the lowest number position that results in the green light being on and the red light off (reference the "Electronic Power Brush Monitor" section).
4. **Depress the foot pedal to lower the handle to the operating position.**
5. **Turn ON the switch**-the vacuum and brush motors will start. Begin your DRY pick up vacuuming.

OPERATION with ACCESSORIES

1. Properly install the filter bag in the vacuum.
2. Plug the machine's power cable into a properly grounded outlet.
3. Remove the rigid portion of the flexible hose from the lower portion of the vacuum. The brush motor will automatically stop when the hose is removed.
4. Attach the crevice or dusting tool to the wand, turn the vacuum ON and begin.
5. Upon completion, reinsert the rigid portion of the hose into its' retaining hole.

MAINTENANCE

ALWAYS turn the machine power switch OFF and unplug the machine before performing any service. Severe personal injury could result if electrical power is not disconnected.

AFTER EACH USE:

1. **Inspect the vacuum filter bag.** If the bag is full or damaged install a new one.
2. **Check the cord and plug** for nicks, cuts or damage. Report these to your supervisor for correction. Wrap the electrical cord on the hook provided.
3. **Store the vacuum in a clean dry area.**

FULL BAG INDICATOR

Your machine is equipped with a device that senses when airflow inside the vacuum chamber is restricted. The red light located next to the on/off switch will come on when this condition exists. Restricted airflow can be caused by the following conditions:

- A. If vacuum filter bag is full; install a new bag.**
- B. If the bag is not full, there is an obstruction in the system.** Remove the vacuum hose and hold it up to the light; clean out any debris. Next, check the inlet to the power brush housing and clear it of any debris.

ELECTRONIC POWER BRUSH MONITOR

The machine is equipped with a control system that alerts the operator via indicator lights if a problem occurs within the power brush housing. The lighting conditions and what they mean are:

- A. Green Light Illuminated & Red Light Off** - The brush assembly is working properly.
- B. Both Red & Green Lights Illuminated** - Lower the brush, the drive belt may be broken, or change the brush strip.
- C. Red Light Illuminated & Green Light Off** - The brush roller is obstructed and cannot rotate. Turn the power switch off and unplug the machine. Remove any string, debris or other obstruction so that the brush turns freely.

VACUUM INLET FILTER

This machine has a vacuum inlet filter (Drawing 1, Item 69) that will require periodic cleaning or replacement. The filter is located below the paper bag cage in the housing.

To clean: Remove the filter and shake or vacuum it. If the filter is worn or uncleanable, replace.

HEPA FILTER

The hepa filter (Drawing 1, Item 49) will also require periodic cleaning or replacement.

To clean: Unlatch the cover (Drawing 1, Item 50) to access the hepa filter, remove the filter and shake or vacuum it. If the filter is worn or uncleanable, replace.

BRUSH STRIP REPLACEMENT

This machine has a removable brush strip. Replace it if it becomes worn to the point where it no longer contacts the carpet. **To replace:** First remove the three (3) screws that hold the access plate on the bottom of the brush housing. Once the brush roller is exposed, remove the R.H. Support. The brush strip can now slide off - remove and replace with a new one. Be sure the strip is pushed all the way in. Reassemble.

VACUUM MOTOR MAINTENANCE

Have the vacuum motor inspected annually by a Factory Authorized Service Technician. If the carbon brushes are worn, they should be replaced. This service will prolong the life of the vacuum motor.

The replacement of belts and other repairs to the machine should be performed by a Factory Authorized Service Technician.

NOTES

TANK & VACUUM ASSEMBLY

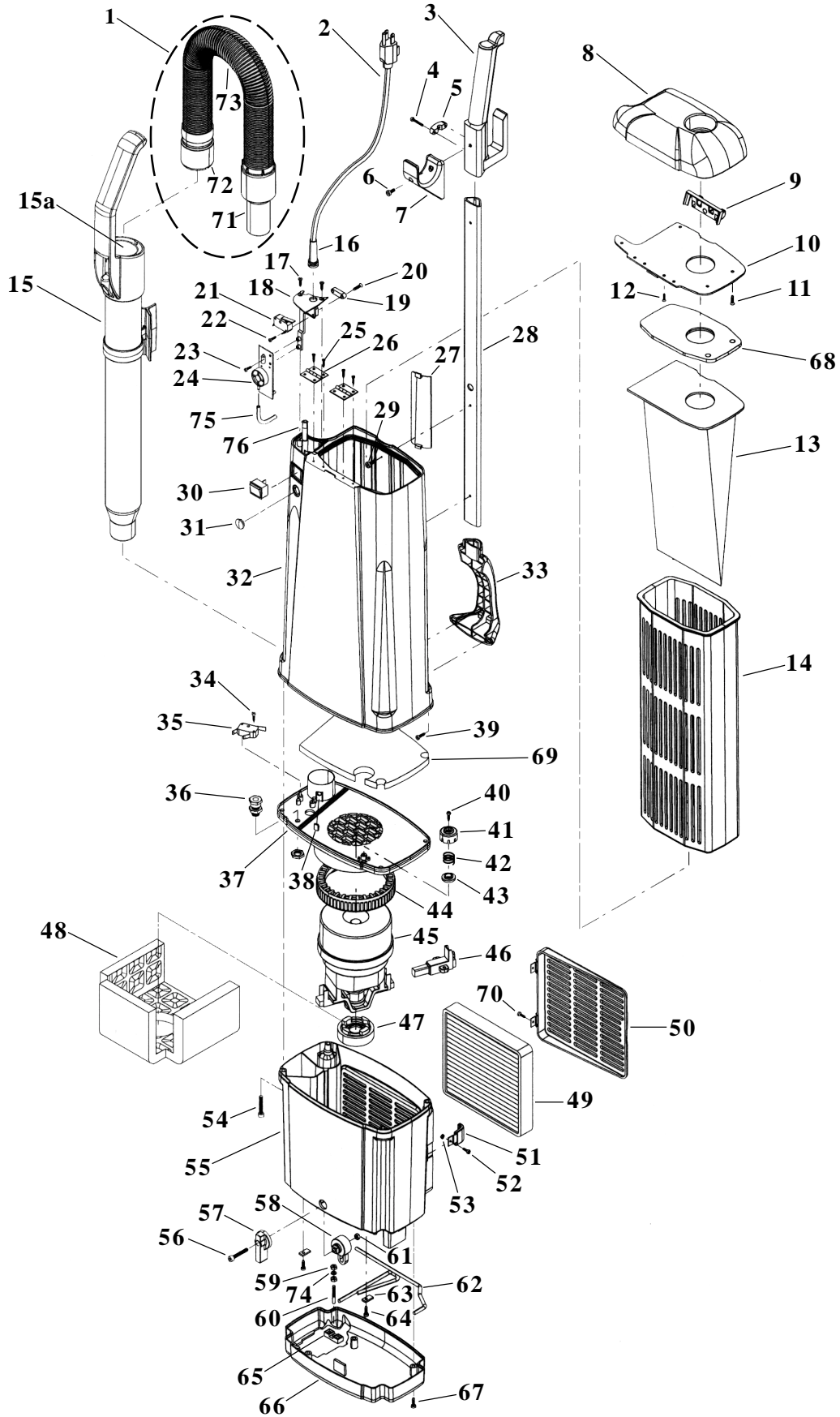

PARTS LIST - TANK & VACUUM ASSEMBLY

ITEM	PART NO.	DESCRIPTION	QTY.	ITEM	PART NO.	DESCRIPTION	QTY.
1	644120	Hose Assembly	1	41	642302	Safety Valve Cover	1
2	908099	Electric Cable	1	42	648301	Safety Valve Cover Spring	1
3	643920	Handle Grip	1	43	649401	Safety Valve	1
4	964152	Screw M3x20	2	44	643403	Vacuum Motor Gasket	1
5		Cable Clamp	1	45	625201	Vacuum Motor 115V	-
6	964153	Screw M4x12	1		645208	Vacuum Motor, 115V	1
7	648520	Suction Hose Support	1	46	620904	Carbon Brush for 625201 VacMtr	2
8	642320	Top Cover	1		640910	CarbonBrush-645208 VacMtr (Brown Holder)	2
9	648320	Closing Cover Spring	1				
10	646620	Closing Cover Plate	1	47	643401	Rubber Gasket	1
11	964154	Self-Threading Screw 3, 5x16	4	48	644820	Sound Insulation	1
12	964155	Self-Threading Screw 2, 9x13	4	49	643320	HEPA Filter	1
13	640620	Paper Bag, 10 Pack	1		643307	Foam Filter	1
14	642420	Paper Bag Cage	1	50	642323	Filter Cover	1
15	649820	Rigid Wand (no Inner Tube)	1	51	642020	Filter Retaining Clamp	1
15a	649021	Tube, Rigid Wand Inner	1	52	964162	Screw M3x10	1
16	647501	Cable Retainer	1	53	920630	Nut M3	3
17	964156	Self-Threading Screw 3, 5x13	2	54	964141	Screw M5x30	4
18	646621	Support Plate	1	55	644220	Motor Housing	1
19	642001	Cable Holder	1	56	964141	Screw M5x30	1
20	964155	Self-Threading Screw 2, 9x13	2	57	645103	Locking Catch/Knob	1
21	911252	Microswitch	1	58	645102	Locking Catch	1
22	964158	Self-Threading Screw 2, 9x16	1	59	920631	Nut M4	3
23	964159	Self-Threading Screw 2, 9x9, 5	2	60	646720	Static Ground Pin	1
24	911253	Paper Bag Control Card	1	61	924065	Self-Locking Nut M5	1
25	964155	Self-Threading Screw 2, 9x13	4	62	647420	Locking-Rod	1
26	644520	Cover Hinge	2	63	647202	Latch	2
27	642321	Cover	1	64	964163	Self-Threading Screw 3, 5x13	2
28	649020	Handle Tube	1	65	643601	Connection Protection	1
29	964137	Screw M4x10	2	66	642322	Vacuum Motor Cover	1
30	911193	Switch	1	67	964021	Self-Threading Screw 3, 5x16	4
31	645120	Lens	1	68	643420	Gasket	1
32	641320	Upright Central Body/Housing	1	69	643321	Vacuum Inlet Filter	1
33	643921	Lifting Handle	1	70	964164	Screw M3x8	2
34	964158	Self-Threading Screw 2, 9x16	1	71	648120	Black Rotating Sleeve	1
35	911252	Microswitch	1	72	649320	Flexible Hose Union	1
36	647220	Cable Retainer	1	73	644121	Flexible Hose	1
37	644020	Vacuum Motor Holder	1	74	980639	Washer	1
38	911254	Micro Switch	1	75	644122	Connection Hose Pressure Reg.	1
39	964021	Self-Threading Screw 3, 5x16	2	76	647021	Post, Rubber	1
40	964138	Self-Threading Screw 3, 9x13	1				

BRUSH HEAD ASSEMBLY

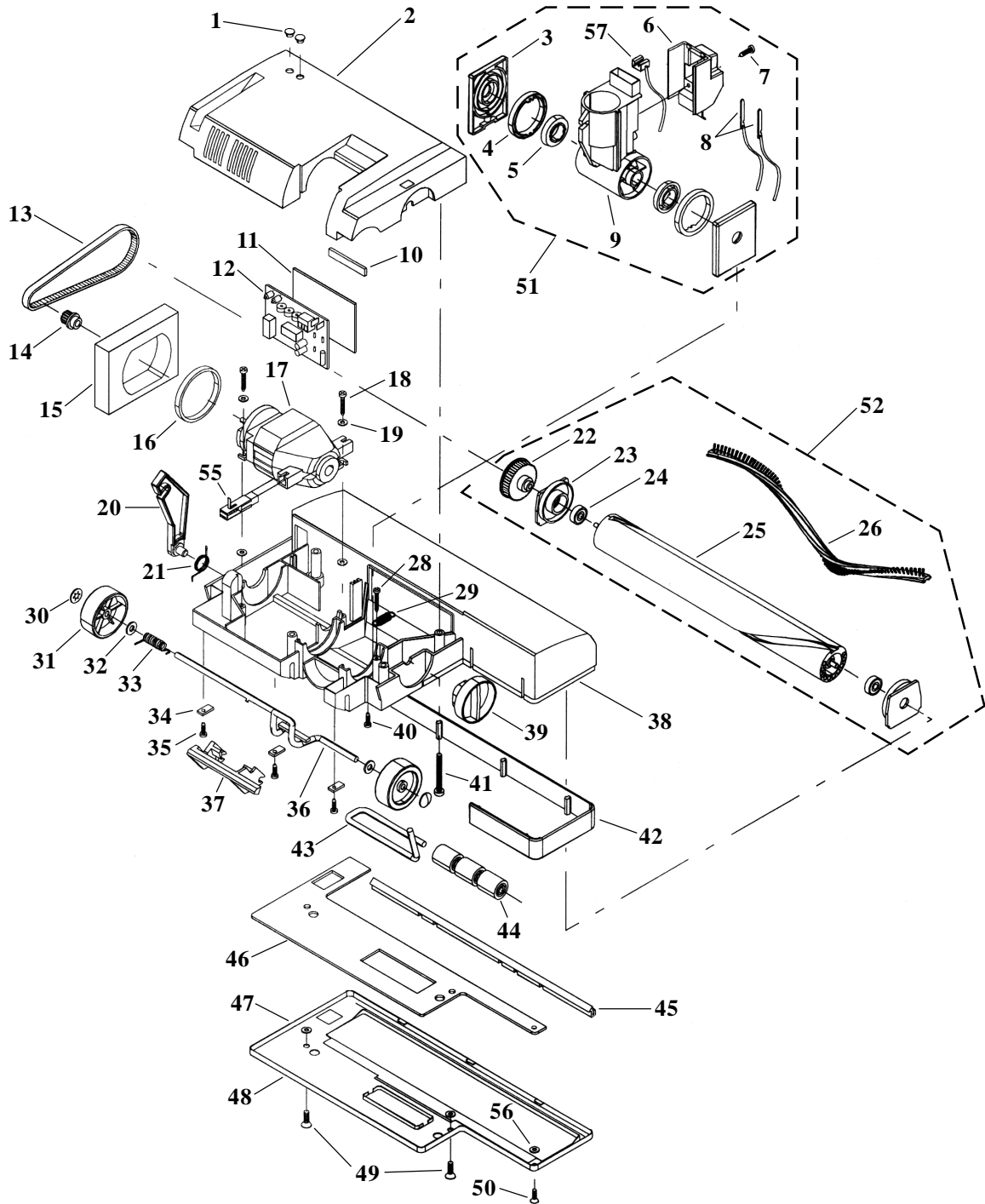

PARTS LIST - BRUSH HEAD ASSEMBLY

ITEM	PART NO.	DESCRIPTION	QTY.
1	645121	Lens	2
2	642303	Base Cover	1
3	648502	Swivel Neck Support Wiring	2
4	641120	Bushing	2
5	641121	Bushing	2
6	642305	Joint Cover	1
7	964136	Self-Threading Screw 3, 9x16	2
8	911255	Wire on Swivel Neck	1
9	644901	Swivel Neck	1
10	647620	Felt Seal	2
11	911256	Electronic Card Protection	1
12	641302	Electronic Card 115V F350E	1
13	903017	Belt	1
14	646902	Pulley	1
15	643322	Filter	1
16	643421	Gasket	1
17	645201	Brush Motor, 115V - 14"	1
	645202	Brush Motor, 115V - 18"	1
18	964157	Self-Threading Screw 3, 9x19	2
19	980640	Washer D4	4
20	645105	Support Lever	1
21	648304	Spring	1
22	646901	Brush Pulley	1
23	648503	Brush Support	2
24	902034	Bearing	2
25	642401	Brush Core w/shaft - 14"	1
	642404	Brush Core w/shaft - 18"	1
26	640920	Brush Strip - 14"	1
	640921	Brush Strip - 18"	1
28	964160	Self-Threading Screw 3, 5x25	1

ITEM	PART NO.	DESCRIPTION	QTY.
29	648305	Spring	1
30	647201	Retainer	2
31	649701	Wheel	2
32	980641	Washer D6	2
33	648302	Wheels Axle Spring	1
34	647202	Latch	3
35	964138	Self-Threading Screw 3, 9x13	3
36	647701	Wheels Axle	1
37	647020	Foot Pedal	1
38	644201	Chassis/Housing, Brush - 14"	1
	644202	Chassis/Housing, Brush - 18"	1
39	645001	Brush Height Adjustment Knob	1
40	964138	Self-Threading Screw 3, 9x13	2
41	964139	Screw M5x45	4
42	641201	Bumper - 14"	1
	641202	Bumper - 18"	1
43	640502	Wheels Axle	1
44	647502	Brush Adjustment Wheels	3
45	643408	Gasket	1
46	643409	Gasket	1
47	980636	Washer	2
48	647901	Shoe, Pick-Up - 14"	1
	647902	Shoe, Pick-Up - 18"	
49	964150	Screw M5x12	2
50	964149	Screw M4x10	1
51	644920	Complete Joint W/Support	1
52	640904	Complete Brush, 14"	1
55	640922	Carbon Brush	2
56	980637	Washer	1
57	648321	Enclosing Cover Spring	1

ACCESSORIES

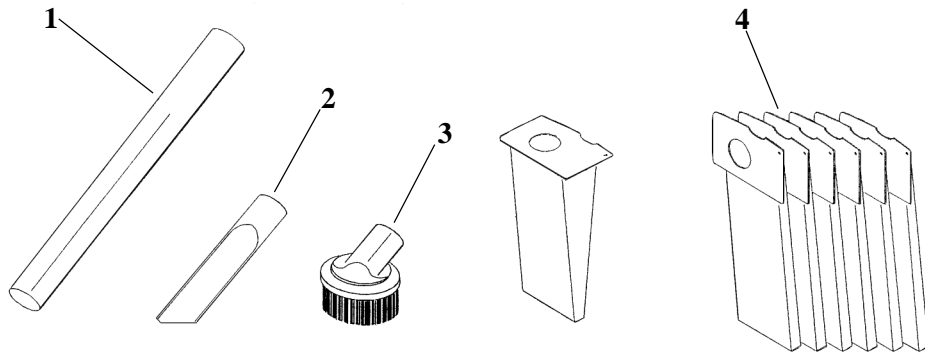

ITEM	PART NO.	DESCRIPTION	QTY.
1	649001	Tube-Extension	1
2	648801	Crevice Tool	1
3	648802	Dusting Brush	1
4	640620	10 Pack Paper Bags	1

WIRING DIAGRAM

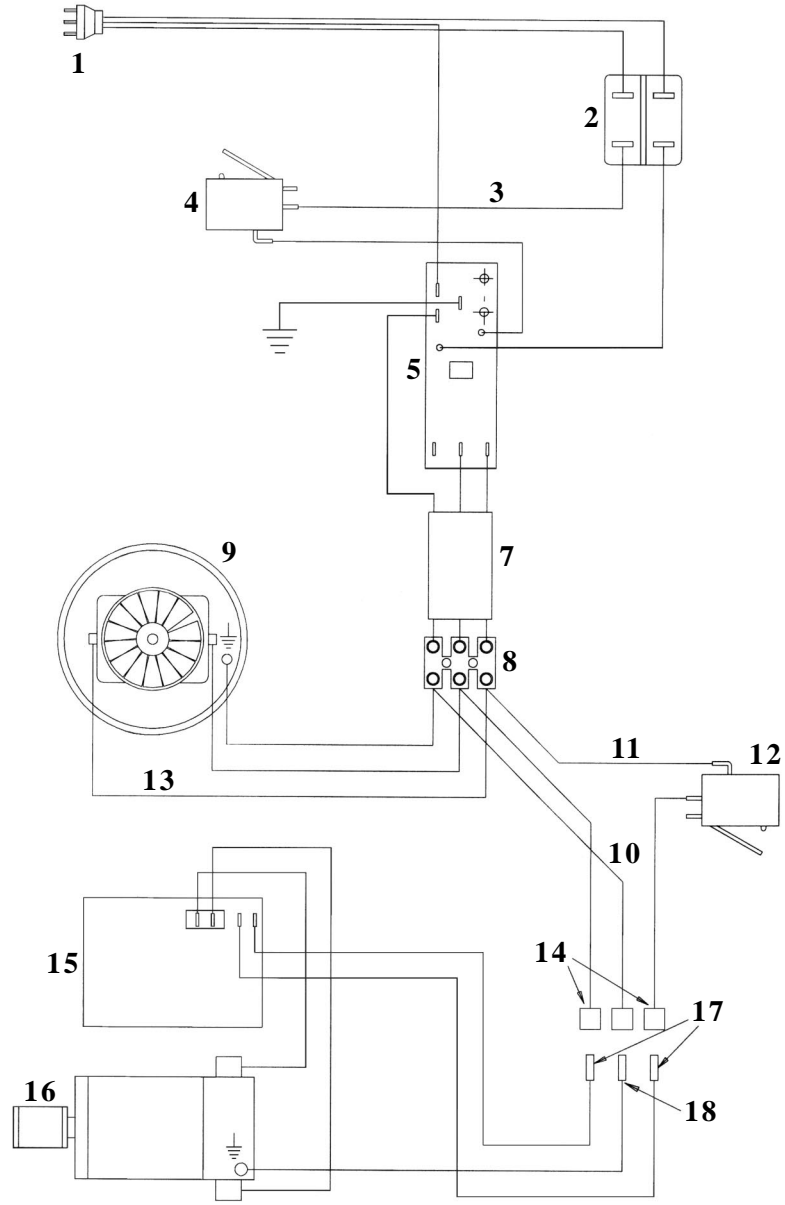

ITEM	PART NO.	DESCRIPTION	QTY.
1	908099	Electric Cable	1
2	911193	Switch	1
3	911257	Lead Assembly	1
4	911252	Microswitch	1
5	911253	Control Card	1
7	911258	Electric Cable Assembly	1
8	911259	Terminal board Mannut	1
9	625201	Vacuum Motor 115V	1
10	911260	Grounding Lead	2
11	911201	Elec.Lead Asm.-Microswitch	1

ITEM	PART NO.	DESCRIPTION	QTY.
12	911252	Microswitch	1
13	911264	Elec.Lead Asm.-Vacuum Motor	2
14	911262	Contact Plug	1
15	641302	Electronic Card 115V - 14"	1
	641303	Electronic Card 115V - 18"	1
16	645201	Brush Motor 115V - 14"	1
	645202	Brush Motor 115V - 18"	1
17	911255	Wire on Swivel Neck	1
18	648321	Enclosing Cover Spring	1
19	911263	Antistatic Cable	1

WARRANTY POLICY PACIFIC LIMITED WARRANTY

The **Pacific** Genius 14 and Genius 18 have been manufactured, tested and inspected in accordance with specific engineering requirements and is **WARRANTED** to be free from defects in workmanship and materials as follows:

Three (3) years parts, one (1) year labor - Vacuum Motor and Brush Motor.

One (1) year parts & labor - All other components unless excluded below.

This warranty extends to the original user/purchaser and only when used, operated and maintained in accordance with **Pacific** Operating and Maintenance instructions.

This warranty does not apply to the following wear parts and accessories of the machine including:

Part Number	Part Name
908099	Cord Assembly
644121	Flexible Hose
640920	Brush Strip-14"
640921	Brush Strip-18"
903017	Belt
643321	Filter
643320	Hepa Filter
640620	Paper Bag Filters
641201	Bumper-14"
641202	Bumper-18"
640910	Carbon Brush, Vac Motor
640922	Carbon Brush, Brush Motor

Nor does it apply to damage or failure caused by improper use, abuse or neglect. Warranty credit or replacement of return parts including motors, pumps, etc., is subject to incoming inspection of those items.

To secure repair under this warranty, the following procedure should be taken:

- The inoperative machine or warranted parts must be delivered to the authorized dealer with shipping and delivery charges prepaid. If unable to locate the Dealer, you may contact **Pacific** at the address listed herein for the location of the nearest **Pacific** repair center or agent or for other instructions pertaining to your warranty difficulty.
- Upon compliance with the above warranty procedure, all warranted repairs would be completed at no additional charge or cost to the user.
- Only **Pacific** or its authorized dealers and agents may make no charge warranty repairs on this product. All others do so at their own risk.

This warranty limits **Pacific's** liability to the repair of the product and/or warranted parts replacement and does not include incidental or consequential damages arising from the use of a **Pacific** machine whether defective or not.

This warranty is in lieu of all other expressed or implied warranties and is extended to the original purchaser/user.

PACIFIC

2259 Sheridan
Muskegon, Michigan 49442
Ph: (800) 968-1332 Fax: (231) 773-1642

www.nextwaveofclean.com