



Electronic Service Manuals

This electronic document is provided as a service to our customers. We do not create the contents of the information contained in this document. Should you have detailed questions pertaining to the information contained in this document, you may contact Michco, or the manufacturer which provided the original information in this electronic deliverable. Michco's only part in this electronic deliverable was the electronic assembly process. By providing this manual on line we are not guaranteeing parts availability.

You may contact Michco through the following methods:

Phone (517) 484-9312 or (800) 331-3339

2011 N. High St. -- Lansing, Michigan -- 48906

Fax: (517) 484-9836

Email: CustServe@Michco.com

Web site: www.Michco.Com

Parts Web site: www.FloorMachineParts.Com

Order Parts on Line at:

www.FloorMachineParts.Com

Directly to Parts & Service:

By Email: **Shop@Michco.com**

By Fax: (517) 702-2041

By Voice: Use numbers above.

Serving the Cleaning Industry Since 1922

Notice: All copyrighted material remains property of original owners, all trademarks are property of respective owners. Manuals are subject to Manufacturer's reproduction limitations. Originals or reproductions were provided by manufacturers through a request. We make no warranty as to the correctness of information provided in this document and you assume all risk. By placing these manuals on line we are not declaring our corporation to be an manufacturer authorized dealer or provider, please check our web site for authorized manufacturers we represent.

The WIZ

INTRODUCTION

OPERATING & MAINTENANCE INSTRUCTIONS

READ THIS BOOK

This operator's book has important information for the use and safe operation of this machine. Read this book carefully before starting the machine. Keep this book and tell all operators to read the book. If you do not follow the instructions, you can cause an injury or damage equipment, furniture or buildings.

For new books write to:

Pacific
2259 S. Sheridan
Muskegon, MI 49442-6252

Carefully inspect all components to ensure that there is no concealed freight damage. If such damage is discovered, file a "CONCEALED DAMAGE REPORT" immediately with the delivering carrier.

The contents of this manual are based on the latest product information available at the time of publication. Pacific reserves the right to make changes or improvements to its machines without notice.

FOR YOUR CONVENIENCE, RECORD THE FOLLOWING INFORMATION:

MODEL _____

SERIAL NUMBER _____

PART NUMBER _____

DATE PURCHASED _____

IMPORTANT SAFETY INSTRUCTIONS

When using an electrical appliance, basic precautions should always be followed, including the following:

READ ALL INSTRUCTIONS BEFORE USING THIS MACHINE

WARNING: to reduce risk of fire, electric shock, or injury:

1. Do not leave appliance when plugged in. Unplug from outlet when not in use and before servicing.
2. Do not use outdoors or on wet surfaces.
3. Do not allow to be used as a toy. Close attention is necessary when used by or near children.
4. Use only as described in this manual. Use only manufacturer's attachments.
5. Do not use with damaged cord or plug. If appliance should not work as it should, has been dropped or damaged, left outdoors, or dropped into water, return it to service center.
6. Do not pull or carry by cord, use cord as handle, close a door on cord or pull cord around sharp edges or corners. Do not run appliance over cord. Keep cord away from heated surfaces.
7. Do not unplug by pulling on cord. To unplug, grasp the plug, not the cord
8. Do not handle plug or appliance with wet hands.
9. Do not put any objects into opening. Do not use with any opening blocked: keep free of dust, lint, hair and anything that may reduce airflow.
10. Keep hair, loose clothing, fingers and all parts of the body away from openings and moving parts.
11. Turn off all controls before unplugging.
12. Use extra care when vacuuming on stairs.
13. Do not use to pick up flammable or combustible liquids such as gasoline or use in areas where they may be present.
14. Connect to a properly grounded outlet only.
15. Do not pick up anything that is burning or smoking, such as cigarettes, matches or hot ashes.
16. Do not use without dust bag and/or filters in place.
17. Do not use this vacuum for pick-up of wet debris; this vacuum is for dry pick-up only.

Grounding Instructions

This machine must be grounded. If it should malfunction or break down, grounding provides a path of least resistance for electric current to reduce the risk of electric shock. This machine is equipped with a cord having an equipment-grounding conductor and grounding plug. The plug must be inserted into an appropriate outlet that is properly installed and grounded in accordance with all local codes and ordinances.

WARNING - Improper connection of the equipment-grounding conductor can result in a risk of electric shock. Check with a qualified electrician or service person if you are in doubt as to whether the outlet is properly grounded. Do not modify the plug provided with the machine - if it will not fit the outlet, have a proper outlet installed by a qualified electrician.

This machine is for use on a nominal 120-volt circuit, and has a grounded plug that looks like the plug illustrated in figure A. A temporary adapter that looks like the adapter illustrated in figures B and C may be used to connect this plug to a 2-pole receptacle as shown in figure B if a properly grounded outlet is not available. The temporary adapter should be used only until a properly grounded outlet (figure A) can be installed by a qualified electrician. The green colored rigid ear, lug, or the like extending from the adapter must be connected to a permanent ground such as a properly grounded outlet box cover. Whenever the adapter is used, it must be held in place by a metal screw.

NOTE: In Canada, the use of a temporary adapter is not permitted by the Canadian Electrical Code

EXTENSION CORDS

Use only three-wire 16/3 or larger gauge approved extension cords that have three-prong grounding type plugs and three-pole receptacles that accept the appliance's plug. Replace or repair any damaged cords or plugs.

When servicing, refer to authorized person only. Use only identical replacement parts.

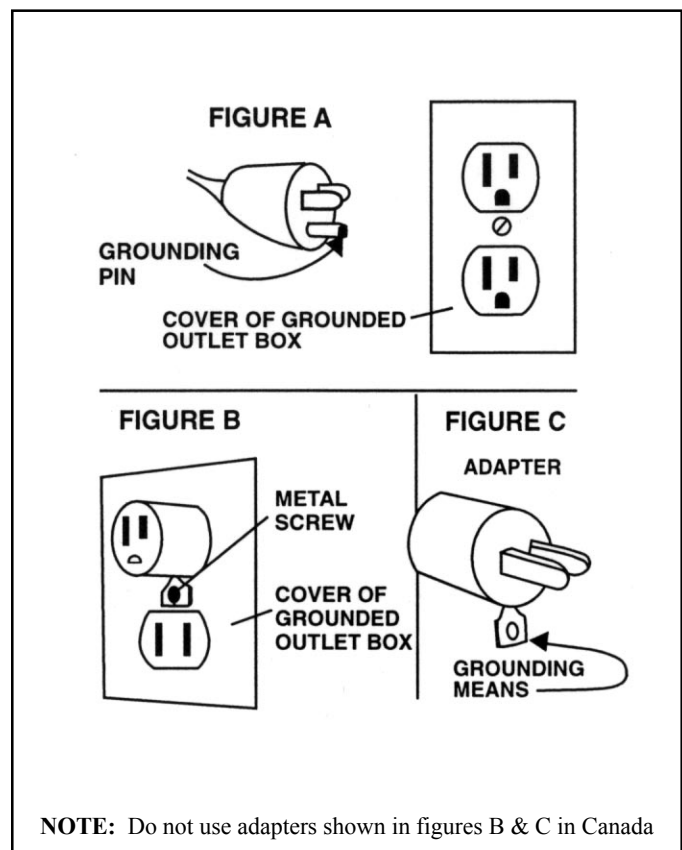

ASSEMBLY AND OPERATION

Unpack your vacuum from its carton and inspect the machine, hose assembly and tools for any damage. If there is damage to any component, file a claim with the carrier immediately.

Assembly

This machine requires little assembly before operation. However, the following steps must be taken to ensure proper operation.

1. Install a **filter bag** into the tank. To do this, release the hook located on each side of the machine's tank and motor assembly. Lift the cover off and set it aside. Install the filter bag by pushing its opening over the vacuum hose adapter. Be sure the filter bag follows the perimeter of the tank; the center area must remain clear for replacement of the cover with motor assembly. Replace the cover and fasten both hooks.
2. Insert the **vacuum hose assembly** securely into the adapter. Then attach the wand and selected tool. The wand and tools attach by simply pushing them together.

Operation

The Model shown in this manual is intended for commercial use and is to be used for **only dry pick-up applications**.

1. Before use, be sure a **filter bag** has been properly installed in the machine (reference assembly instructions).
2. Attach the **hose assembly, wand and selected tools**.
3. Plug the **power cord** into a 115-volt, 60 cycle, grounded outlet.
4. Turn the **power switch** on; the vacuum motor will start. The switch is located on the handle.
5. The **vacuum suction** is adjustable through an opening located on the bent wand section of the hose assembly. For maximum pick-up the opening must be closed, for reduced suction expose the opening.

Tools

Four tools are provided with the vacuum: the combination floor assembly, upholstery tool, crevice tool and dusting brush. Each is used by inserting them directly into the free end of the vacuum hose/wand.

The **combination floor assembly tool** can be utilized either with or without bristles. The levers located on top of the tool actuate the bristles.

Servicing

Warning: Always unplug your vacuum before performing any service. Severe personal injury could result if the electrical power is not disconnected.

1. **Vacuum Filter Bag:** When full, remove the paper filter bag and install a new one. If the optional cloth filter bag is being used, it must be emptied when full and checked for any rips or holes. Replace if necessary.
2. **Power Cord:** Check the cord for cuts or nicks. If damaged, have the cord replaced at a factory authorized service center.
3. **Casters:** Remove any strings or debris that may restrict the free movement of the casters. Wipe the treads clean.
4. **Tools:** Inspect the tools to ensure there is no obstruction of airflow. Remove any debris if found.
5. **Motor Filter Bag:** This vacuum has a cloth filter bag that protects the motor assembly. This filter will require periodic cleaning; remove any dust and debris by vacuuming with a different vacuum cleaner.
6. **Vacuum Motor Maintenance:** Have the vacuum motor inspected annually by a factory authorized service technician. If the carbon brushes are worn, they should be replaced. This service will prolong the life of the vacuum motor.

The Wiz

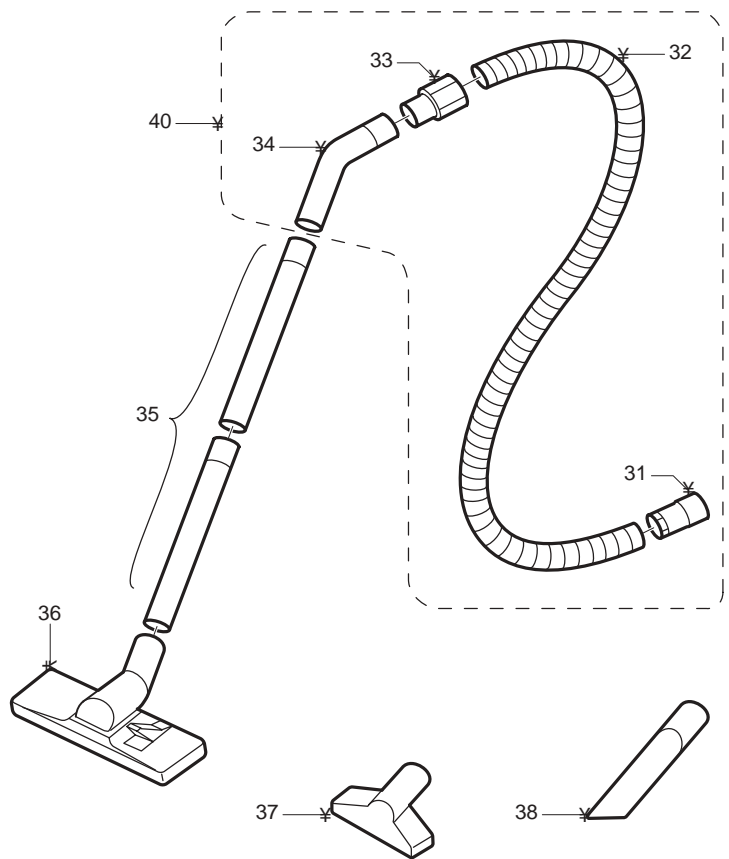
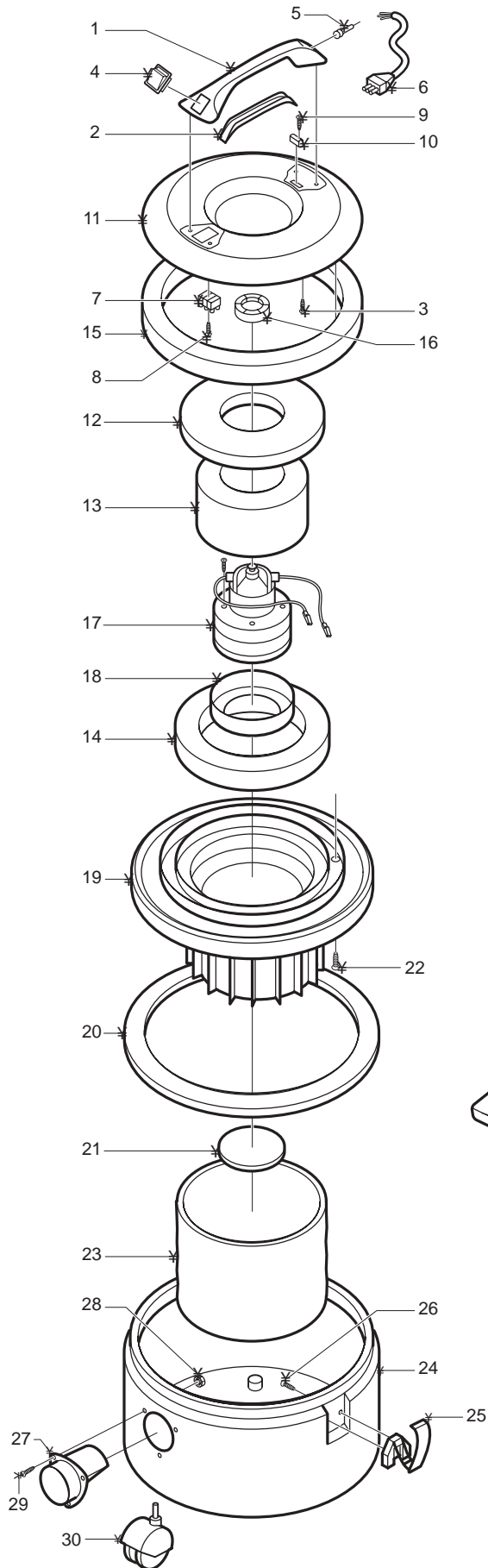

Not Shown:

41. Included: Part Number 600643, Paper Bag Filters-Pkg. of 10

The WIZ

ITEM #	PART #	DESCRIPTION	QTY
Machine			
1	603940	Handle	1
2	602341	Cover-Handle	1
3	964142	Screw	4
4	608010	Switch	1
5	607540	Cable Retainer	1
6	908081	Cord Assembly	1
7	911203	Terminal Board	1
8	964021	Screw	1
9	964021	Screw	2
10	607541	Retainer	1
11	601541	Motor Cap	1
12	604840	Insulation-Sound	1
13	604841	Insulation-Sound	1
14	604842	Insulation-Sound	1
15	604843	Insulation-Sound	1
16	603440	Gasket-Motor Exhaust	1
17	605240	Vacuum Motor 115V	1
18	603410	Vac. Motor Gasket	1
19	602342	Cover-Tank	1
*20	603443	Gasket-Cover	1
21	604844	Insulation-Sound	1
22	964143	Screw	6
23	600642	Filter Bag-Motor	1
24	608641	ABS Tank	1
25	604540	Hook	2
26	964144	Screw	4
27	600241	Adaptor-Vac.Hose	1
28	924065	Self-Locking Nut	2
29	964145	Screw	2
30	609740	Caster	4
Hose Assembly & Tools			
31	600209	Adapter-Hose to Tank	1
32	604140	Hose-Vacuum	1
33	600243	Adapter-Hose to Wand	1
34	609041	Tube-Bent Wand Top	1
35	609812	Tube-Straight Wand	2
36	608840	Combination Floor Tool Asm.	1
37	608818	Upholstery Tool	1
38	608815	Crevice Tool	1
39	608814	Dusting Brush	1
40	604141	Vacuum Hose Assembly	1
41	600643	Paper Bag Filters-Pkg.of 10	1

*Indicates part number change since last revision.

WARRANTY POLICY PACIFIC LIMITED WARRANTY

The **Pacific** WIZ Vacuum has been manufactured, tested and inspected in accordance with specific engineering requirements and is WARRANTED to be free from defects in workmanship and materials as follows:

One (1) year parts & labor - All components unless excluded below.

This warranty extends to the original user/purchaser and only when used, operated and maintained in accordance with **Pacific** Operating and Maintenance instructions.

This warranty does not apply to the following wear parts and accessories of the machine including:

Part Number	Part Name
908081	Cord Assembly
604140	Hose - Vacuum
604141	Vacuum Hose Asm
600642	Filter Bag, Motor
600643	Paper Bag Filters
608840	Floor Tool Asm.
608818	Upholstery Tool
608815	Crevice Tool
608814	Dusting Brush

Nor does it apply to damage or failure caused by improper use, abuse or neglect. Warranty credit or replacement of return parts including motors, pumps, etc., is subject to incoming inspection of those items.

To secure repair under this warranty, the following procedure should be taken:

- The inoperative machine or warranted parts must be delivered to the authorized dealer with shipping and delivery charges prepaid. If unable to locate the Dealer, you may contact **Pacific** at the address listed herein for the location of the nearest **Pacific** repair center or agent or for other instructions pertaining to your warranty difficulty.
- Upon compliance with the above warranty procedure, all warranted repairs would be completed at no additional charge or cost to the user.
- Only **Pacific** or its authorized dealers and agents may make no charge warranty repairs on this product. All others do so at their own risk.

This warranty limits **Pacific's** liability to the repair of the product and/or warranted parts replacement and does not include incidental or consequential damages arising from the use of a **Pacific** machine whether defective or not.

This warranty is in lieu of all other expressed or implied warranties and is extended to the original purchaser/user.

PACIFIC

2259 Sheridan
Muskegon, Michigan 49442
Ph: (800) 968-1332 Fax: (231) 773-1642

www.nextwaveofclean.com