



Electronic Service Manuals

This electronic document is provided as a service to our customers. We do not create the contents of the information contained in this document. Should you have detailed questions pertaining to the information contained in this document, you may contact Michco, or the manufacturer which provided the original information in this electronic deliverable. Michco's only part in this electronic deliverable was the electronic assembly process.

You may contact Michco through the following methods:
Phone (517) 484-9312 or (800) 331-3339 MI, OH, IN only
2011 N. High St. -- Lansing, Michigan -- 48906
Fax: (517) 484-9836
Email: CustServ@Michco.com
Web site: www.Michco.Com
Parts Web site: www.FloorMachineParts.Com

Order Parts on Line at:
www.FloorMachineParts.Com

Directly to Parts & Service:
By Email: **Shop@Michco.com**
By Fax: (517) 702-2041
By Voice: Use numbers above.

Serving the Cleaning Industry Since 1922

Notice: All copyrighted material remains property of original owners, all trademarks are property of respective owners. Manuals are subject to Manufacturer's reproduction limitations. Originals or reproductions were provided by manufacturers through a request. We make no warranty as to the correctness of information provided in this document and you assume all risk.

MINI-EDGER POLISHER/SCRUBBER

INTRODUCTION

OPERATING & MAINTENANCE INSTRUCTIONS

READ THIS BOOK

This operator's book has important information for the use and safe operation of this machine. Read this book carefully before starting the machine. Keep this book and tell all operators to read the book. If you do not follow the instructions, you can cause an injury or damage equipment, furniture or buildings.

For new books write to:

Pacific
2259 S. Sheridan
Muskegon, MI 49442-6252

Carefully inspect all components to ensure that there is no concealed freight damage. If such damage is discovered, file a "CONCEALED DAMAGE REPORT" immediately with the delivering carrier.

The contents of this manual are based on the latest product information available at the time of publication. Pacific Steamex reserves the right to make changes or improvements to its machines without notice.

**FOR YOUR CONVENIENCE, RECORD THE
MACHINE MODEL AND SERIAL NUMBER:**

MODEL _____

SERIAL NUMBER _____

PART NUMBER _____

DATE PURCHASED _____

IMPORTANT SAFETY INSTRUCTIONS

To assure the safe operation of this machine, you must read and understand all warnings and instructions in this book. If you do not understand, ask your supervisor.

READ ALL INSTRUCTIONS BEFORE USING THIS MACHINE!

WARNING! To reduce the risk of fire, electric shock, or injury:

1. You must be trained to operate this machine. This machine is to be operated for its intended use only.
2. Do not operate this machine unless it is completely assembled.
3. Do not connect this machine to improper voltage. Always use a 3-wire grounded electrical supply. See the Grounding Instructions below.
4. To prevent electrical shock, always disconnect the electrical plug of the machine from the electrical outlet before performing an repairs, maintenance or cleanup and when leaving the machine unattended.
5. Keep the machine surface dry. Do not subject to rain. Store the machine in a dry building area. Clean the machine with a dry cloth only.
6. Machines can cause an explosion when near flammable materials and vapors. Do not use or store this machine with or near fuels, grain dust, solvents, thinners, or other flammable materials. Do not use flammables to clean this machine.
7. Maintenance and repairs on this machine must be done by a qualified or authorized person.
8. If the machine is not working as it should, has been dropped, damaged, left outdoors, or dropped into water, return it to a service center.
9. Avoid damage to the machine's electrical cord. Always lift the machine over the cord. Do not run the machine over the cord.
10. Make sure all labels, decals, warnings, cautions and instructions are fastened to the machine.

Grounding Instructions

This machine must be grounded. If it should malfunction or break down, grounding provides a path of least resistance for electric current to reduce the risk of electric shock. This machine is equipped with a cord having an equipment-grounding conductor and grounding plug. The plug must be inserted into an appropriate outlet that is properly installed and grounded in accordance with all local codes and ordinances.

WARNING - Improper connection of the equipment-grounding conductor can result in a risk of electric shock. Check with a qualified electrician or service person if you are in doubt as to whether the outlet is properly grounded. Do not modify the plug provided with the machine - if it will not fit the outlet, have a proper outlet installed by a qualified electrician.

This machine is for use on a nominal 120-volt circuit, and has a grounded plug that looks like the plug illustrated in figure A. A temporary adapter that looks like the adapter illustrated in figures B and C may be used to connect this plug to a 2-pole receptacle as shown in figure B if a properly grounded outlet is not available. The temporary adapter should be used only until a properly grounded outlet (figure A) can be installed by a qualified electrician. The green colored rigid ear, lug, or the like extending from the adapter must be connected to a permanent ground such as a properly grounded outlet box cover. Whenever the adapter is used, it must be held in place by a metal screw.

NOTE: In Canada, the use of a temporary adapter is not permitted by the Canadian Electrical Code

EXTENSION CORDS

Use only three-wire 16/3 or larger gauge approved extension cords that have three-prong grounding type plugs and three-pole receptacles that accept the appliance's plug. Replace or repair any damaged cords or plugs.

When servicing, refer to authorized person only. Use only identical replacement parts.

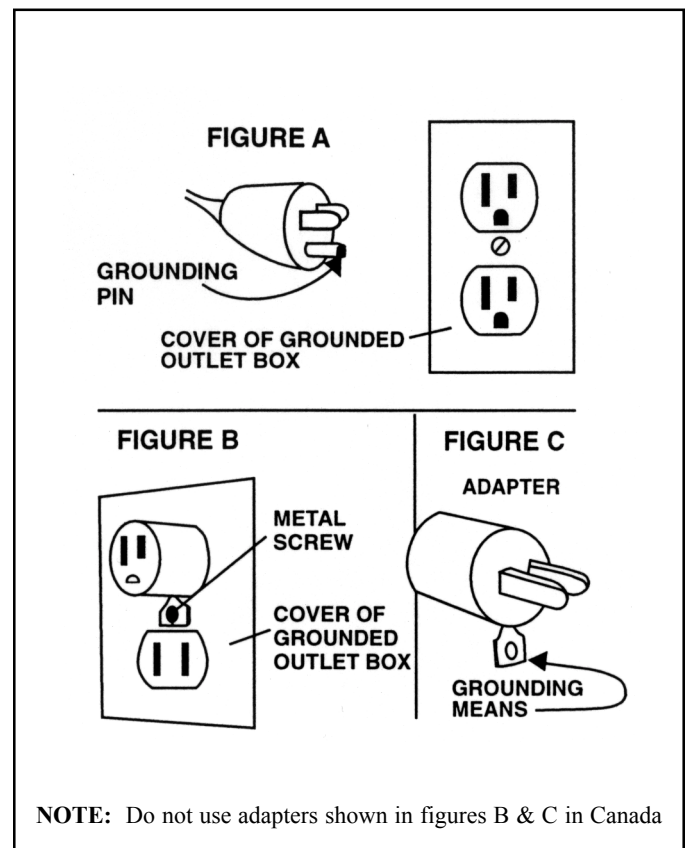

OPERATING PROCEDURES

WARNING! For the safe operation of this machine follow the instructions given in this booklet and the training given by your supervisor. Failure to do so can result in personal injury and/or damage to machine and property!

DO NOT OPERATE MACHINE IN AN EXPLOSIVE ENVIRONMENT!

The model shown in this manual is intended for commercial use.

PREPARATION

To prepare the machine for operation, make sure it is of correct voltage and properly assembled.

Your new floor machine operates in the normal side to side motion of a conventional single disc machine. Be prepared before starting by removing all obstructions or other obstacles in the area to be cleaned. Check the proper application recommendations and procedures found on the label of your cleaning or finish container. **IF IN DOUBT, CALL YOUR SUPERVISOR.**

WARNING! NEVER USE THIS MACHINE WITH FLAMMABLE OR EXPLOSIVE MATERIAL!

For Scrubbing or Polishing: Select the correct floor pad or brush (your supplier can help you). If in doubt, ask your supervisor. **DO NOT USE BLACK PADS** with this unit due to possible motor overloading.

NEVER OPERATE THE MACHINE WITHOUT THE FLOOR PAD OR BRUSH INSTALLED!

To properly attach the brush, **UNPLUG THE FLOOR MACHINE**, lay the machine on its side and remove the screw in the bottom of the drive adaptor. Position the brush or pad on the drive adaptor. Assemble the attachment screw and tighten.

OPERATION

Plug the machine's power cable into a properly grounded outlet (see Safety Instructions). Next, adjust the handle height to a comfortable position.

Start the machine by depressing the trigger switch in the handle.

The machine will glide sideways over the floor by a slight raising and lowering of the handle. Raise the handle slightly to go left, or lower the handle slightly to go right. **Releasing the switch lever stops the machine.**

MAINTENANCE

AFTER EACH USE: Store the machine in a clean dry area. Wipe the entire machine and cord down with a clean cloth. **CHECK** the cord and plug for nicks, cuts or damage. Report these to your supervisor for correction. Remove the pad or brush and clean thoroughly.

NOTE: To prevent brush damage and reduce wobble problems, do not store the unit with the machine weight on the brush. Either remove the brush or support the unit on a hook while in the storage position.

WARNING! Always disconnect the machine's electrical plug from the electrical outlet before performing any service, maintenance, pad changing or inspection of the machine.

MOTOR: The motor is lubricated for life under normal use. No oiling or greasing is necessary.

If you have any questions regarding the maintenance of your floor machine, **ASK YOUR SUPERVISOR.**

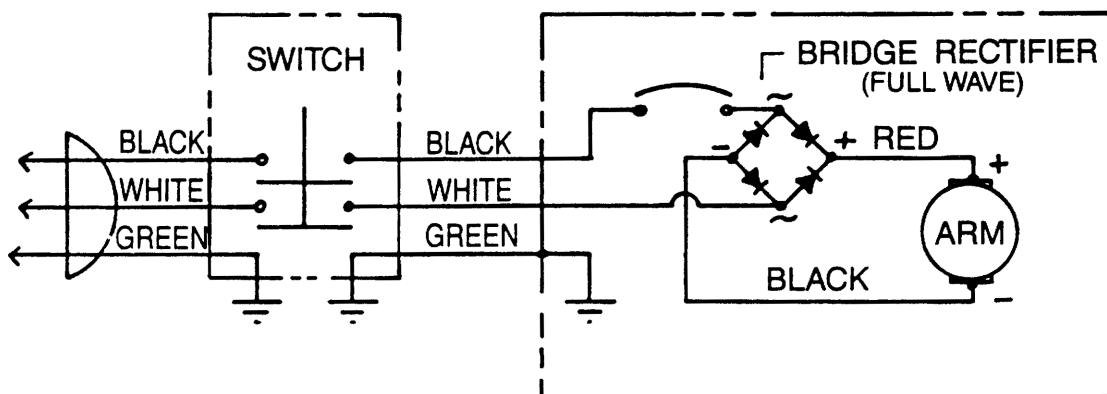

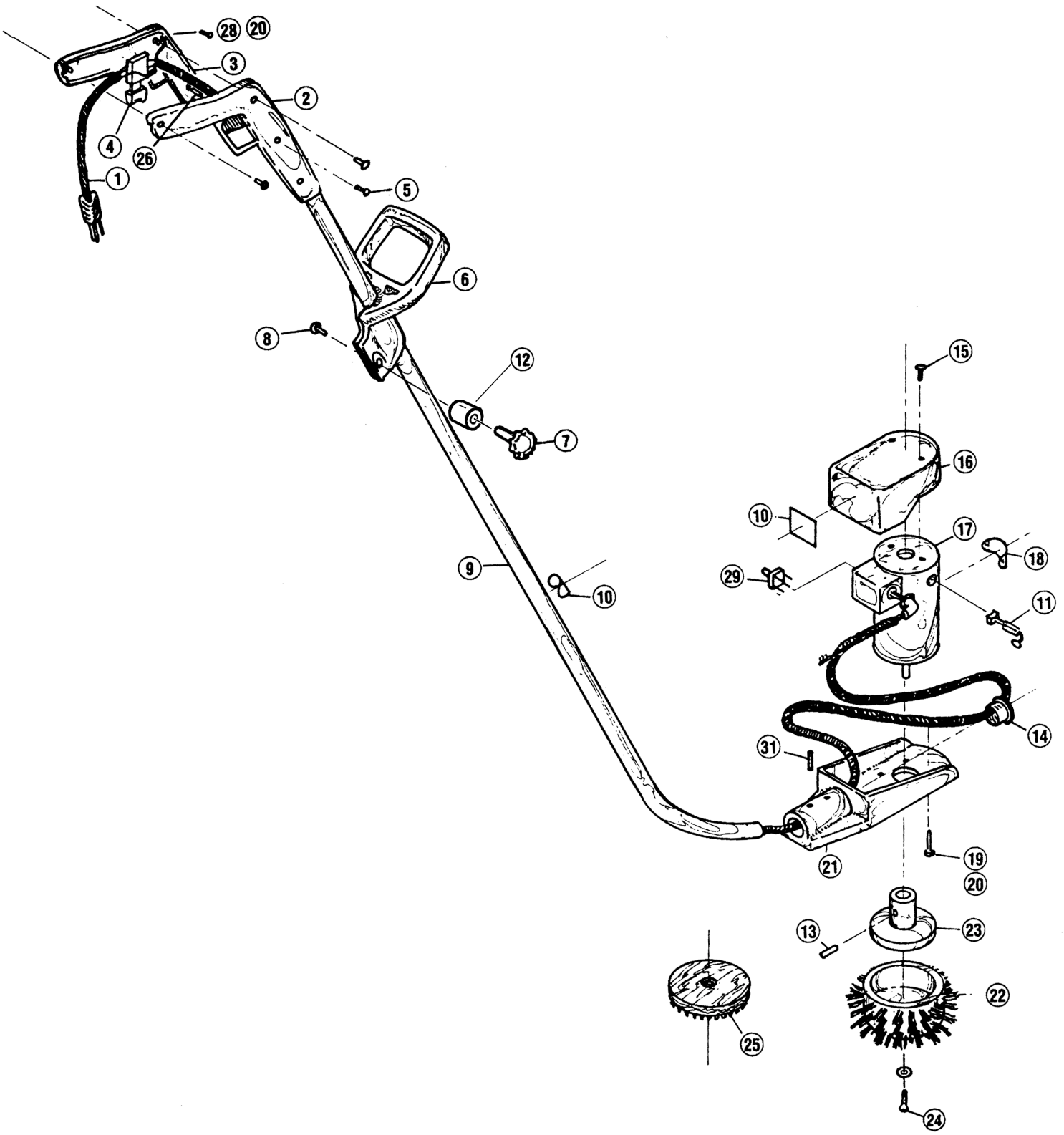

MINI-EDGER PARTS LIST

ITEM	PART NUMBER	DESCRIPTION	QTY
1	908048	Power Cord	1
2	513950	Handle-Right	1
3	513951	Handle-Left	1
4	911064	Switch-Trigger	1
5	962145	Screw	4
6	513971	Handle, Adjusting	1
7	515050	Knob, Fluted	1
8	962037	Bolt, 5/16-18x1-3/4 Carriage	1
9	519051	Handle Tube	1
10	515150	Label, Warning	2
11	510951	Brush, Motor (1/4" Square-Leeson Mtrs)	2
	510961	Brush, Motor (5/16" Square-Met Mtrs)	
12	518203	Spacer, Knob	1
13	962005	Screw, 1/4-20x3/8 Allen Set	1
14	511150	Bushing, Snap	1
15	962029	Screw, 10-24x1/2 PHP	2
16	512355	Cover, Motor	1
17	515257	Motor-Drive, 1/8 HP-DC, 115V	1
	515258	Motor-Drive, 1/8 HP-DC, 230V	1
18	225194	Label-Pacific Steamex	1
19	962019	Screw, 10-32x5/8 PHP	6
20	980015	Washer, #10 Ext Tooth Lock	6
21	511359	Base, Motor	1
22	510950	Brush, Scrub	1
23	510252	Adaptor, Motor	1
24	962040	Screw, 5/16-24x1-1/4 Flat Hd.	1
	980037	Washer, 5/16 Ext Tooth	1
25	512760	Disc, Pad Drive	1
	518561	Support, Pad Holder	1
26	518250	Spacer, Handle	2
28	962015	Screw, 10-32x3/8 PHP	2
29	911066	Rectifier, Motor (for 115 or 230 Volt Motors)	1
31	962042	Screw, 1/4-20x1/2 Allen Set	2

AVAILABLE ACCESSORY PADS	
973001	6-1/2" Brown Stripping Pads, Case of 10
973002	6-1/2" Red Spray Buff Pads, Case of 10
973003	6-1/2" White Polish Pads, Case of 10

NOTES

NOTES

**WARRANTY POLICY
MINI-EDGER
POLISHER/SCRUBBER**

The **Pacific** Mini-Edger has been manufactured, tested and inspected in accordance with specific engineering requirements and is **WARRANTED** to be free from defects in workmanship and materials as follows:

One (1) year parts & labor – All components unless excluded below.

This warranty extends to the original user/purchaser and only when used, operated and maintained in accordance with **Pacific** Operating and Maintenance instructions.

This warranty does not apply to the following wear parts and accessories of the machine including:

Part Number	Part Name
908048	Power Cord
510950	Brush, Scrub
512760	Disc, Pad Drive

Nor does it apply to damage or failure caused by improper use, abuse or neglect. Warranty credit or replacement of return parts including motors, etc., is subject to incoming inspection of those items.

To secure repair under this warranty, the following procedure should be taken:

- The inoperative machine or warranted parts must be delivered to the authorized dealer with shipping and delivery charges prepaid. If unable to locate the Dealer, you may contact **Pacific** at the address listed herein for the location of the nearest **Pacific** repair center or agent or for other instructions pertaining to your warranty difficulty.
- Upon compliance with the above warranty procedure, all warranted repairs would be completed at no additional charge or cost to the user.
- Only **Pacific** or its authorized dealers and agents may make no charge warranty repairs on this product. All others do so at their own risk.

This warranty limits **Pacific** liability to the repair of the product and/or warranted parts replacement and does not include incidental or consequential damages arising from the use of a **Pacific** machine whether defective or not.

This warranty is in lieu of all other expressed or implied warranties and is extended to the original purchaser/user.

PACIFIC

2259 Sheridan

Muskegon, Michigan 49442

Ph: (800) 968-1332 Fax: (231) 773-1642