



Electronic Service Manuals

This electronic document is provided as a service to our customers. We do not create the contents of the information contained in this document. Should you have detailed questions pertaining to the information contained in this document, you may contact Michco, or the manufacturer which provided the original information in this electronic deliverable. Michco's only part in this electronic deliverable was the electronic assembly process.

You may contact Michco through the following methods:
Phone (517) 484-9312 or (800) 331-3339 MI, OH, IN only
2011 N. High St. -- Lansing, Michigan -- 48906
Fax: (517) 484-9836
Email: CustServ@Michco.com
Web site: www.Michco.Com
Parts Web site: www.FloorMachineParts.Com

Order Parts on Line at:
www.FloorMachineParts.Com

Directly to Parts & Service:
By Email: **Shop@Michco.com**
By Fax: (517) 702-2041
By Voice: Use numbers above.

Serving the Cleaning Industry Since 1922

Notice: All copyrighted material remains property of original owners, all trademarks are property of respective owners. Manuals are subject to Manufacturer's reproduction limitations. Originals or reproductions were provided by manufacturers through a request. We make no warranty as to the correctness of information provided in this document and you assume all risk.

SILVER BULLET

CENTERFIRE

24" & 27"

INTRODUCTION

OPERATING & MAINTENANCE INSTRUCTIONS

READ THIS BOOK

This operator's book has important information for the use and safe operation of this machine. **Read and understand the Engine Operator's Manual and this manual before starting the machine.** Keep this book and tell all operators to read the book. **If you do not follow the instructions, you can cause an injury or damage equipment, furniture or buildings.**

For new books write to
Pacific Steamex, Inc.
2259 S. Sheridan
Muskegon, MI 49442-6252

Carefully inspect all components to ensure that there is no concealed freight damage. If such damage is discovered, file a "CONCEALED

DAMAGE REPORT" immediately with the delivering carrier.

The contents of this manual are based on the latest product information available at the time of publication. Pacific Steamex reserves the right to make changes or improvements to its machines without notice

FOR YOUR CONVENIENCE, RECORD THE MACHINE AND ENGINES MODEL AND SERIAL NUMBERS HERE:

MACHINE MODEL _____
MACHINE SERIAL NUMBER _____
ENGINE MODEL _____
ENGINE SERIAL NUMBER _____

TABLE OF CONTENTS

IMPORTANT SAFETY INSTRUCTIONS.....	3
OPERATING PROCEDURES.....	4
A. Check the Engine Oil	
B. Properly Fill and Check LP Tank and Lines for Leaks	
C. Connecting the High Pressure Hose to the LP Tank	
D. Prepare the Floor	
E. Installing Pads	
F. Center Fire Punch Solution Mix	5
G. Starting the Onan Engine	
H. Center Fire Operations	
I. Buffing Operations	
J. Stopping the Engine	
K. Transporting the Machine	6
L. Storing the Machine	
MAINTENANCE.....	6
A. Machine Maintenance	7
B. Changing the Drive Belt	
C. Changing the Angle of Attack & the Head Pressure	
D. Center Fire Maintenance: Machine Will Not Feed Punch	8
E. Center Fire Feed System Leaks	
TROUBLE SHOOTING GUIDE.....	9
A. No Charge to Battery	
B. Battery Continuously Charges at a High Rate	
C. Starter will Not Engage with Key in Start Position	
D. Starter Engages when Key is in OFF Position	
E. Amber Ignition Light Does Not Come On	10
F. Green Oil Pressure Light Does Not Come On or Goes Off while Engine is Trying to Start	
G. Green Oil Pressure Light Goes Off and Engine Dies	
H. Green Oil Pressure Light Goes Off and Engine Continues to Run	11
I. New Engine will Crank, but will Not Cold Start	
J. New Engine will Not Crank	
K. New Engine Cranks and Starts, But Does Not Run Well	
L. New Engine Cranks, Starts and Runs Good for up to One Hour then Loses Power	12
M. New Engine Consumes Oil at a Rate Greater than ½ Ounce per Hour	
ILLUSTRATION GUIDE.....	13
PAD DRIVER ASSEMBLY	14
RAIL & HUB ASSEMBLY	15
HANDLE & THROTTLE ASSEMBLY	16
WHEEL ASSEMBLY	
TANK ASSEMBLY	17
BRACKET ASSEMBLY	
HANDLE BRACKET & HP HOSE ASSEMBLY	18
REGULATOR ASSEMBLY	
IGNITION ASSEMBLY	19
BATTERY ASSEMBLY	
FRAME ASSEMBLY	20
ENGINE ASSEMBLY	
CENTER FIRE BOTTLE ASSEMBLY	21
CENTER FIRE SHAFT ASSEMBLY	
CENTER FIRE SWITCH ASSEMBLY	22
WIRING, CENTER FIRE	
OPTIONAL CENTRIFUGAL CLUTCH ASSEMBLY	23
WIRING DIAGRAM	
WARRANTY POLICY.....	24

IMPORTANT SAFETY INSTRUCTIONS

READ AND UNDERSTAND ALL INSTRUCTIONS AND WARNINGS BEFORE OPERATING THIS MACHINE!

WARNINGS:

1. **DO NOT STORE OR USE GASOLINE OR OTHER FLAMMABLE VAPORS AND LIQUIDS IN THE VICINITY OF THIS MACHINE.**
2. **NO SMOKING, NO SPARKS, NO FLAMES NEAR UNIT OR LP TANK.**
3. **OPERATE ONLY IN WELL VENTILATED AREAS. BUILDINGS MUST BE PROVIDED WITH :**
 - A) **A CONTINUOUS MECHANICAL VENTILATION THAT REMOVES THE PRODUCTS OF COMBUSTION TO THE OUTDOORS OF NOT LESS THAN 300 CFM FOR EACH 10,000 BTUH OR FRACTION THEREOF; OR**
 - B) **NATURAL VENTILATION OF NOT LESS THAN 300 CFM FOR EACH 10,000 BTUH INPUT OR FRACTION THEREOF, BASED ON A MAXIMUM OF ONE-QUARTER AIR EXCHANGE PER HOUR FOR THE NET BUILDING VOLUME.**
4. **IF YOU SMELL LP GAS, STOP THE UNIT AND CHECK FOR LEAKS. ALSO OPEN WINDOWS, DON'T TOUCH ELECTRICAL SWITCHES, EXTINGUISH ANY OPEN FLAMES. CALL YOUR GAS SUPPLIER IF NO LEAKS ARE FOUND.**
5. **DO NOT ADJUST THE FUEL SYSTEM WITHOUT THE PROPER ANALYSIS EQUIPMENT.**
6. **NEVER TURN THE UNIT ON ITS SIDE.**
7. **KEEP HANDS AND FEET CLEAR OF ALL MOVING PARTS.**
8. **TURN THE GAS OFF AT THE TANK, THEN TURN IGNITION TO OFF POSITION TO KILL THE ENGINE.**
9. **REMOVE THE LP TANK AND STORE IT IN AN APPROVED AREA WHEN NOT IN USE. A "NO SMOKING" SIGN SHOULD BE PERMANENTLY DISPLAYED AT THE STORAGE AREA.**
10. **KEEP ALL OBJECTS CLEAR OF THE EXHAUST SYSTEM DURING AND AFTER OPERATION. IT WILL BE VERY HOT AND TAKE SEVERAL MINUTES TO COOL!**
11. **DO NOT LEAVE THIS MACHINE UNATTENDED WHILE THE ENGINE IS RUNNING.**
12. **WHEN THE LP TANK IS ATTACHED TO THE MACHINE AND NOT RUNNING, THE OPERATOR SHOULD NOT LEAVE THE MACHINE UNATTENDED EXCEPT FOR SHORT PERIODS OF TIME SUCH AS REST STOPS, WASHROOM OR MEAL STOPS.**
13. **THE OPERATOR MUST COMPLETELY UNDERSTAND ALL INSTRUCTIONS, WARNINGS AND OPERATING PROCEDURES BEFORE USING THIS MACHINE.**
14. **THIS MACHINE MUST BE MAINTAINED IN ACCORDANCE WITH THIS MANUALS RECOMMENDED MAINTENANCE INSTRUCTIONS AND THE ENGINE MANUFACTURERS RECOMMENDED MAINTENANCE PROCEDURES. FAILURE TO DO SO MAY CAUSE DAMAGE TO THE MACHINE, EQUIPMENT, FURNITURE, BUILDINGS OR PERSONAL INJURY!**

OPERATING PROCEDURES

WARNING! Follow the instructions given in this booklet, the Engines Owners Manual and the training given by your supervisor for the safe operation of this machine. Failure to do so can result in personal injury and/or damage to the machine or property.

DO NOT OPERATE THIS MACHINE IN AN EXPLOSIVE ENVIRONMENT!

The Silver Bullet Center Fire System is designed to be a complete daily maintenance system when used with the Center Fire Punch Buffing Compound. It does not take the place of scrubbing and finishing. It is intended for commercial use

A. CHECK THE ENGINE OIL BEFORE EVERY OPERATION!

Make sure the machine is level when checking the oil. Always take 2 readings of the dip stick before adding oil. If the oil level is below the full mark, add just enough oil to the engine to bring the oil level up to the full mark. **Never over fill.** Follow the guidelines in your Engine Owners Manual. Check for foreign material on the dipstick.

B. PROPERLY FILL AND CHECK YOUR LP TANK AND ALL LP FUEL LINES FOR LEAKS!

1. Every tank we sell has been pressure and leak tested. However, **every time a tank is filled and/or connected to the machine it should be soap tested.** All LP lines must be pressurized and every inch of line and connections must be sprayed. If you find a leak, make the proper repairs before operating the machine. **NOTE:** The connection and disconnection of the LP tank must be done in a well ventilated area with NO source of ignition within 10 feet (3 meters) from the point of connection.

2. **Never over fill the LP tank.** Your buffer's LP tank is designed to hold just 20 pounds of propane. Make sure to weigh the tank as it is being filled. The gross weight of a full tank should not exceed 48 pounds. If while operating the machine you notice frost forming on the LP lines or the regulator, your tank has been over filled. If you continue to operate the machine in this condition damage will occur. The excess propane in the tank must be removed before

normal operations resume. The bleeding of a propane tank should be done in a safe location outside the building. In some cases the regulator must defrost before restarting the engine.

C. CONNECTING THE HIGH PRESSURE HOSE TO THE LP TANK: Make sure the couplers are in line and screwed together hand tight (see page 18). If this is not done properly, fuel will not pass through to the regulator.

D. PREPARE THE FLOOR BY: dusting, wet cleaning any large spills and wet cleaning any spills that run under shelves

E. INSTALL A FRESH PAD BEFORE EVERY JOB; if not new, at least clean

For Center Fire operations the cleaning pad does not have to be a coarse pad. In most cases, an open type polish pad will work well **REMEMBER TO BE KIND TO THE FLOOR FINISH, USE THE LEAST AGGRESSIVE PAD THAT WILL DO THE JOB.** However, don't be afraid to use an aggressive pad when floor conditions so dictate. In most cleaning applications ETC pads deliver superior results when used with the Center Fire System. The following pads are recommended: Superspeed Rubberized, Gorilla Lite, Jaguar, Aqua Plus, Gorilla and the 3/4" light blue, ultra high speed cleaning pad.

During operation, remove and wash the cleaning pad at least every time you fill the Center Fire Bottle; more often if needed.

Never run the cleaning pad dry on the floor! Run it damp! If you run it dry, you will be polishing with a dirty pad.

To install a fresh pad, set the machine down in the rear. Unscrew and remove the yellow pad-centering ring. See page 14, the "Pad Driver Assembly". Remove the old pad and center the new pad onto the pad driver. Reinstall the yellow pad-centering ring. Never "flip" a pad. Keep the same side down throughout the life of the pad. Even after a pad is cleaned, you can tell the down side by the centering ring indentation. This practice will increase the pad life and help maintain a properly functioning pad driver. **NEVER TILT A MACHINE ON ITS SIDE!**

OPERATING PROCEDURES

F. CENTER FIRE PUNCH SOLUTION MIX

USE ONLY CENTER FIRE PUNCH THROUGH THE MACHINE (Part Number 271196, case of four gallons). Read and follow the instructions on the Center Fire Punch container. A mixture of one (1) part Punch and six (6) parts cold water is recommended; a richer solution may cause excessive loading of the polish pad. The solution may be mixed in the bottle on the machine; however don't spill water or Punch down the outside of the solution tank. If this happens, clean it up.

F. STARTING THE ONAN ENGINE.

1. Make sure you have completed items A, B, C, D, E and F (if applicable) above. Also make sure the fuel is on at the tank. Set the machine down in the rear.
2. Pull the throttle back to the rear (see page 16)
3. Turn the ignition switch key clockwise (one notch) to the ON position. The Amber ignition light will come on (see page 19).
4. Turn the ignition switch key clockwise again one notch to the START position and crank the engine.
5. When the engine starts, release the key. The green oil pressure light on the right side of the display panel will glow. This glow indicates proper oil pressure. **If the engine loses oil pressure this green light will not glow and the engine will shut itself down. If this happens you must correct the problem before the engine will restart.**

H. CENTER FIRE OPERATIONS

1. Set the throttle for medium rpm.
2. Press the thumb switch to apply the punch solution to the floor. When the punch solution reaches the floor, move the machine forward at a slow walking pace. Apply the punch solution at regular intervals: about every 4th step. Remember to depress the thumb switch and hold it in for about 2 seconds every cycle. As the operator, you are in control of the machine and the feed. Too much punch solution and the wheels will track. Too little punch solution and the floor will not be cleaned. Track marks can be buffed out on the polishing pass. But again,

track marks indicate that too much punch solution is being used

3. Stay about 3" away from the edges while you are applying the punch solution and cleaning the floor. One bottle of punch solution should clean up to 20,000 square feet (when applied as stated in step 2). But remember that consumption will vary according to your floors' condition.

4. When the cleaning process is complete, **STOP THE ENGINE** (see SECTION J), move the machine to the cleaning station and remove the cleaning pad. Wash the pad immediately with hot water under high pressure. Hang the pad to drip dry.

5. **Install a CLEAN and DRY polishing pad onto the machine before buffing.** A pad softer and finer than the cleaning pad is best for most applications. Then move back onto the floor area.

I. BUFFING OPERATIONS

1. Start the Onan Engine as detailed in G
2. Keep hands, fingers and feet clear of all moving parts while the machine is in operation.
3. Lower the buffing deck to the floor and set the throttle to the desired buffing speed. **Always keep the machine moving while the pad is touching the floor.** Buff the entire floor. Remember, this time stay as close to the edges as possible.

If the pad overloads and begins to leave swirl marks, stop buffing and clean the pad. **Only a clean, dry polishing pad should be used for this operation.** If pad overloading continues to be a problem try using a weaker punch solution and/or a more open weave polishing pad.

J. STOPPING THE ENGINE.

1. Pull the throttle back and low idle the engine.
2. Turn the propane tank valve clockwise to a closed position.
3. After engine dies, turn the ignition switch to the OFF position. In an emergency the engine can be stopped electrically by only turning the ignition switch OFF. However, never make it common practice to kill the engine this way!

OPERATING PROCEDURES

K. TRANSPORTING THE MACHINE.

1. The tank should be securely fastened.
2. The tank valve must be closed.
3. The transport area should be well ventilated.

L. STORING THE MACHINE.

1. The engine should be stopped properly and

the tank valve closed.

2. Remove the LP tank from the machine and store the tank in an approved area.

3. Store your machine in a safe area: away from enclosed high heat, away from sparks or flames, away from traffic lanes of heavy equipment.

REFER TO SAFETY INSTRUCTIONS!

MAINTENANCE

A. MACHINE MAINTENANCE

1. Change the oil and filter according to the Onan Engine Owners Manual. Change the oil at the first 10 hours of operation. Thereafter, oil should be changed at 30-hour intervals. Use Mobil 1 (15-50). Always do a wet filter change. Reference Section M under Trouble Shooting for more detail on oil changes.

2. Grease the wheels every 50 hours of operation.

3. Keep the cooling air filter (on top of the engine) clean at all times. Wet clean it at the end of every use. Never operate the machine unless the filter is clean and properly installed.

4. The spark arrester screen must be inspected and or cleaned daily. This screen is a fire safety item and must be maintained regularly in order to keep the engine from over heating.

5. Each week wet clean the carburetor foam pre-filter with soap and water. Blot dry with paper towels and reinstall. Do not treat this filter with oil. Never operate the unit unless the paper element and the pre-filter are properly installed. Install a new paper element every 200 hours of operation. Make sure the PCV tube is properly positioned in the filter plate and that the

filter plate is in position on top of the filter. The filter cowing must seat inside the filter tray. If this is not done, the cowing when secured by the wing nut will depress the PCV tube and cause engine failure.

6. Each week check the water level in the battery. Fill as needed. Keep the battery terminals clean.

7. Clean the entire unit after each use.

8. When cleaning the unit, check for possible loose nuts and bolts.

9. Check the bearing hub shaft and bearings weekly. If the shaft shows any looseness, the bearings and possibly the shaft must be replaced.

10. Check the pad driver weekly for rigidity and wear. Replace the harpoon face as needed.

11. Check the spark arrester screen in the muffler exhaust port for debris on a daily basis. Any accumulation is an indication of premature catalyst deterioration. Unless debris is removed, over heating will occur.

Remember that being safe is a full-time, every day job. Follow all information posted on the machine and the LP tank.

MAINTENANCE

12. Soap test for LP leaks at least every time you install a fresh LP tank. To do this test properly, the LP lines must be pressurized and every inch of line and connections must be sprayed. If you find a leak, make the proper repairs before operating the machine. Also see Item B under Operating Procedures.

Never allow anyone to operate this machine that has not read or cannot understand the given instructions.

B. CHANGING THE DRIVE BELT.

1. The engine should be off and the machine level with the floor.
2. Remove the front cover (7/16-inch wrench).
3. Loosen only (do not remove) the 4 hub plate mounting bolts (3/4-inch wrench). These are the front 2 bolts located on the right and left sides of the main frames above the hood. The third bolt on either side mount the push bar and should not be loosened.
4. Turn the 2 tension rods counter clockwise equal turns until you can push the bearing hub plate to the rear (3/4-inch socket).
5. Remove the old belt and install the new one.
6. Tension the new belt by reversing step #4. The belt should be just tight enough to not slip or squeal. Care must be taken not to over tension the belt. Over tension will cause premature bearing wear.
7. Retighten the 4 bearing hub plate mounting bolts.
8. Replace the front cover.

C. CHANGING THE ANGLE OF ATTACK (PAD TO FLOOR) & THE HEAD PRESSURE.

If the machine has been dropped or you notice a distinct increase in the torque during operation, this adjustment may be needed. For this operation, you will need: a 3/4-inch wrench, a new pad installed on the machine, a framing level, a wood block and shims, and a level floor area on which to set the machine. The end results of this operation should be a machine with framework that sets slightly low in both the

rear and on the right side. The right frame should be 1/8-inch lower than the left frame at the wheel bracket point. You may measure the distance from the top of the axle plate to the top of the main frame to establish this difference.

The 1/8-inch variance from the left to the right is critical for level buffing and ease of operation. If the difference is increased (more than 1/8-inch), torque relief will increase but level buffing will decrease; you will shine harder on the right side of the machine than the left. If the difference is decreased (less than 1/8-inch), torque relief will decrease and level buffing will increase. The machine will be harder to operate. When you get it right, the machine will deliver good level buffing with a minimum of operating effort.

1. Install a new pad onto the machine.
2. Place the machine onto a level floor area.
3. Remove the LP tank.
4. Place the wood block and shims under the tails of the right and left main frames of the machine; enough to slightly raise the wheels from the floor.
5. Loosen the right and left axle brackets, two bolts each.
6. Level the left main frame with the framing level. You will need to remove the wood shims as this is done. Tap the wheel up or down as needed to maintain floor contact. The frame should be slightly low in the rear (about 1/4 inch below level at the tail).
7. When this measure is achieved, tap the left wheel to the floor and tighten the mounting bolts.
8. Now measure the distance between the top of the left wheel bracket and the top of the left main frame.
9. Subtract 1/8-inch from the measurement in step #8. Set the right wheel bracket to this new measurement.
10. Tighten all wheel bracket mounting bolts and remove the wood block and shims.

MAINTENANCE

C. CHANGING THE ANGLE OF ATTACK & THE HEAD PRESSURE CONTINUED.

If the unit seems to over torque after a test run, you may correct this problem by simply raising both wheel brackets equal amounts. This adjustment changes the angle of attack pad to floor and should be made in small 1/8-inch increments. Always keep the right frame 1/8-inch lower than the left at the wheel bracket point

If you desire to increase the head pressure of your unit, simply move the right and left axle brackets to the rear equal amounts. Make this move in 1/2 inch increments. Test run the unit after each adjustment until you reach the desired head pressure. If you find that you have increased the head pressure and increased the torque, the torque may be decreased by raising both the right and left wheels equal amounts. The wheel system on this unit is designed for the professional. There are enough adjustments to make the machine buff any way you want. The ability to control the head pressure and angle of attack are advantageous to level buffing, ease of operation, and superior pad life

D. CENTER FIRE MAINTENANCE: THE MACHINE WILL NOT FEED PUNCH TO THE FLOOR.

Do not attempt to adjust the feed valve! Any adjustments will destroy the valve and seat.

1. **Check for line blockage.** Disconnect the feed tube from the solution bottle. Remove the bottle from the holder and empty the contents. Clear all obstruction from the bottle and the feed lines. If no obstruction is found continue the test

2. **Check the thumb switch and electrical leads.** Near the feed valve disconnect both electrical leads at the spade connectors. These will be tested with a test light. Start the machine and keep the pad off the floor to perform the following tests. Now insert the test light leads into each of the lead wires to be tested. If the

test light glows, the thumb switch is good and stop the engine. Continue with step 3. If the light does NOT glow, then there is a problem with the thumb switch or its' leads. Remove the box end caps and check for continuity between the leads with the thumb switch depressed. If the light still does not glow, the thumb switch must be replaced.

3. **Check the feed valve.** Reconnect the tested leads to the feed valve leads. Start the machine and keep the pad off the floor. Depress the thumb switch - the feed valve should click. If there is no click, replace the feed valve. If there is a click, continue the testing.

4. **Check for feed valve obstruction.** Disconnect the out flow line from the feed valve. Depress the thumb switch and blow through the feed line and into the valve. You should be able to blow through the valve with no restriction. If you can, then the lines below the feed valve must be clogged. If you can not blow through the feed valve it is either clogged or someone has used unauthorized chemical through the machine. If you can clear the obstruction the feed valve should be acceptable for use, however, if the wrong chemical was used the valve must be replaced.

E. IF THE CENTER FIRE FEED SYSTEM LEAKS.

1. **A small leak** indicates that there is an air leak somewhere in the feed line. The solution will drain from the line only below the air leak. Check for air leaks and repair or replace as needed.

2. **A large leak** that would empty the solution bottle if left unattended indicates that the feed valve is the problem. The feed valve may be wedged open by an obstruction. Back blow through the valve to remove any obstruction. If this does not work, disassemble the valve for a complete cleaning. Retest the feed system. If it still leaks or does not feed, replace the feed valve.

TROUBLE SHOOTING GUIDE

A. NO CHARGE TO BATTERY

1. Insert the "+" lead of multimeter to B+ lead of rectifier-regulator, with the negative lead to ground. Check the voltage, it should be battery voltage level or less. Start the engine and run at low idle. Measure the voltage from B+ (at terminal on rectifier-regulator) to ground using a DC voltmeter.

The voltage should be above the battery voltage. As the engine speed increases, the voltage should increase to a maximum of 14.7 volts.

If there is **no increase** in the voltage, the rectifier should be replaced after completing steps 2, 3a and 3b.

2. Remove the connector from the rectifier-regulator. With the engine running at 3100 RPM, measure the AC voltage using an AC voltmeter.

If the voltage is **28 volts or more**, the stator is OK. The rectifier-regulator is faulty and must be replaced.

If voltage is **less than 28 volts**, the stator is probably faulty and should be cleaned and rechecked or replaced. Test the stator further using an ohmmeter (test 3).

3. With the engine stopped, measure the resistance across the stator leads using an ohmmeter.

If the resistance is **0 ohms**, the stator is shorted. Replace the stator. If the resistance is **infinity ohms**, stator is open, replace stator.

4. With the engine stopped, measure the resistance from each stator lead to the ground using an ohmmeter.

If the resistance is infinity ohms (no continuity), the stator is OK. If the resistance (or continuity) is measured, the stator or leads are shorted to ground. Repair the leads or replace the stator as needed.

B. BATTERY CONTINUOUSLY CHARGES AT A HIGH RATE

1. With the engine running at 3100 RPM, measure the voltage from B+ lead to ground using a DC voltmeter.

If the voltage is **14.7 volts or less**, the charging system is OK, but the battery is unable to hold a charge. Service the battery or replace as necessary. If the voltage is **more than 14.7 volts**, the rectifier-regulator is faulty and should be replaced.

C. STARTER WILL NOT ENGAGE WITH KEY IN START POSITION

1. Make sure the battery terminals and leads are clean and secure at all ends.

Retest the starter after completing these checks,

2. Make sure the battery is charged.

Retest the starter after charging the battery. If starter will not engage, go to test 3.

3. Disconnect A5-C2 (SB#5) from solenoid. Attach test light, one probe at SB#5 and one probe to ground. Turn the ignition switch to the ON position.

The light should NOT come on. If light comes ON, replace the key switch. If the light does not come on, go to test 4.

4. With the test light in the same position, turn the ignition switch to the start position.

The test light should come ON. If the light is on, then the starter is probably faulty. If the light does NOT come ON, check the continuity through A5-C2. If continuity is good, replace key switch. If there is no continuity, A5-C2 must be replaced or repaired.

**Note. Onan starters are built to last! Concentrate on finding the problem elsewhere!*

D. STARTER ENGAGES WHEN KEY IS IN OFF POSITION

QUICK, REMOVE GROUND LEAD FROM BATTERY

1. Remove A5-C2 from solenoid. Replace the ground lead to the battery. Connect test light to A5-C2, turn key ON.

If test light comes ON, replace ignition switch.

If starter cranks, replace solenoid.

TROUBLE SHOOTING GUIDE

E. AMBER IGNITION LIGHT DOES NOT COME ON

1. Unplug ground (#0) wire from light and check continuity from #0 to engine ground.

If NO continuity, check wire for break Repair as needed.

2. Check the continuity across the light leads

If NO continuity, replace light. If there is continuity, check ignition switch.

3. Turn ignition switch to ON position. with test light check ACC terminal of ignition switch.

If test light comes on, replace amber light. If test light does not come on, replace ignition switch

F. GREEN OIL PRESSURE LIGHT DOES NOT COME ON OR COMES ON AND GOES OFF WHILE ENGINE IS TRYING TO START.

1. STOP cranking Your engine is protecting itself from being started with little or no oil pressure Check the engine oil level and fill to proper level **Always check the oil level before you hit the ignition!**

2. On occasion, a new engine will shut itself down because of a false sensing from the oil pressure gauge. After ensuring the engine is producing proper oil pressure, complete a bypass start and run Normally, after a one hour break, the problem never again presents itself.

3. If this problem is encountered after the machine has been in service, try testing or replacing the oil pressure sending unit. If this does not correct the problem, it's time for the Onan Warranty Center

If the oil and filter have just been changed, you may experience a hard to start situation We suggest that new oil filters be presoaked and filled with oil before installation.

4. Just to be sure, check the fuse/diode wiring. Remove A5-C2 from the solenoid. With the ignition switch in the START position, use a voltmeter to check volts from the positive side of the ignition coil. If NO volts are read, unplug green light and check fuse/diode for continuity

or resistance. This loop should be closed.

If no volts are read, check that the fuse/diode are plugged in. If continuity or resistance test shows the loop open, check light, fuse and diode and A5-B5 individually.

Note. Diodes are a one way electrical path taking about 2.2 volts to turn on The positive lead of meter must be attached to fuse end of A5-B5 and negative lead to positive post of coil The meter will scale but should read 0.4 volts with a resistance of 800K ohms.

G. GREEN OIL PRESSURE LIGHT GOES OFF AND ENGINE DIES.

1. The engine is protecting itself from being run with little or no oil pressure.

Check the engine oil level and fill to proper level

2. Occasionally the sending unit will become faulty and send a false shut down If your oil level is good and the unit continues to run for a while and then shuts itself down, test the oil sending unit

3. Remove the cowling on the coil side of the engine. With the ignition switch in the ON position, using a multi-meter, check the volts on the oil pressure sending unit. The reading should be equal to the battery voltage.

If this voltage reading is not equal, there is a problem with the wiring. Make the needed repairs

4. If the volts on the sending unit are equal to the battery volts, turn the ignition switch to the OFF position Remove and tape together the two sending unit wire leads Make sure the ends have good contact. Start the engine and test for continuity between the two sending unit posts. If there is NO continuity, SHUT DOWN UNIT IMMEDIATELY!

If there is NO continuity, replace the sending unit. If there is continuity, the sending unit is OK

** If replacing the sending unit does not correct the shut down problem, contact the Onan Warranty Center.*

TROUBLE SHOOTING GUIDE

H. GREEN OIL PRESSURE LIGHT GOES OFF AND ENGINE CONTINUES TO RUN.

1. Complete the test in G.
2. This situation can happen if the green light just burns out or the fuse/diode becomes unplugged while the engine is running and producing oil pressure.

Note If the engine is stopped, it will not restart as long as any of these problems exist.

ENGINE TROUBLE SHOOTING

For an engine to start and run the general requirements are: good compression, good spark at the right time, and fuel in the combustion chamber at the proper flow rate mixed with the proper amount of air. Deviation from standard on any one item or combination may cause a no start, low power, intermittent dying and or unclean running problem. For an engine to start and run with proper power, cooling, fuel efficiency, exhaust emissions and longevity, all systems must be peeking. The ONLY way to achieve this performance level in a working unit is through good solid maintenance and preventive maintenance. Addressing a no start situation may be as simple as a lack of fuel or a loose wire. There again, a no start situation may be as complicated as a total systems failure. A machine that is well maintained will always be easier to fix than one that is not. A visual inspection of the machine will often direct the professional trouble shooter right to the problem.

I. NEW ENGINE (LESS THAN 100 HOURS) WILL CRANK, BUT WILL NOT COLD START.

1. Check and maintain the proper engine oil level.
2. Make sure the LP tank has fuel.
3. Make sure the female coupler on the high pressure fuel hose is properly connected to the male coupler on the tank. It should be hand tight.
4. Make sure the tank valve is open (counter clockwise).
5. If engine still will not start, check to make sure fuel is going to the regulator. Start again with the following steps but DO NOT turn the ignition key on.

- a. Connect high pressure hose to tank and turn on the tank valve.
- b. Turn tank valve off and disconnect the high pressure hose from the tank.
- c. Compress the safety valve stem in the female coupler on the high pressure hose.
- d. If you hear the hose decompress, this means fuel is going to the regulator.
- e. If you do not hear the hose decompress, this means that there is a lack of fuel. Check for an empty tank or a stuck tank valve.

This is not fail safe. It can only indicate whether or not some fuel is available for the regulator. There are many LP tanks in the field that will start and run engines from Honda, Kohler and Briggs, but that will not run and or start an Onan engine. Odd but true. The tank failure problem lies at the base of the tank on/off unit. Connected to the base of the valve unit, inside the tank, there is a spring loaded safety valve. The purpose of this safety valve is to prevent unrestricted fuel escape in case of a high pressure hose rupture. Over a period of time the spring may lose some compression strength allowing the valve to close at a much lower threshold. Even when the valve is closed there is a small amount of fuel allowed to pass through the system. Not enough to run the Onan but just enough to fool you into thinking you have available fuel.

If you have completed these tests and the engine will not start, switch to a different LP tank

J. NEW ENGINE WILL NOT CRANK

Check the following.

1. Battery
2. Ignition
3. Wiring loop
4. Shut down systems check, etc.

K. NEW ENGINE CRANKS AND STARTS, BUT DOES NOT RUN WELL (LOW POWER).

Check the following:

1. Muffler-high heat
2. Spark plug and ignition
3. Tank
4. Adjustments to carburetor
5. Valve settings
6. PCV system

TROUBLE SHOOTING GUIDE

L. NEW ENGINE CRANKS, STARTS AND RUNS GOOD FOR UP TO ONE HOUR-THEN LOSES POWER.

Check the following:

1. Muffler-high heat
2. PCV system
3. Oil level

M. NEW ENGINE CONSUMES OIL AT A RATE GREATER THAN ½ OUNCE PER HOUR.

Check the following

1. PCV system
2. Filters
3. Oil brand-change to Mobil One.

The Onan engine is equipped with an oil drain hose with a twist valve located at the back of the engine. This system works if the oil is hot when drained. The oil filter is located high on the right side of the engine. There is a drain shield around the filter to aid in removing and installing a wet filter. **Remember the first oil and filter change should be done at 10 hours of operation and thereafter at 30 hour intervals.** The oil dipstick and filler tube are located just to the rear of the oil filter. The dipstick may be difficult to remove. The gentle use of pliers may be needed to unscrew the cap. **Check the oil daily before operation.** If the oil level is low, add just enough oil to bring the volume up to the fill mark. Never over fill the crank case. Mobil 1 (15-50) engine oil is recommended, but is not a requirement for Onan warranty.

NOTES

CENTER FIRE 24 & 27

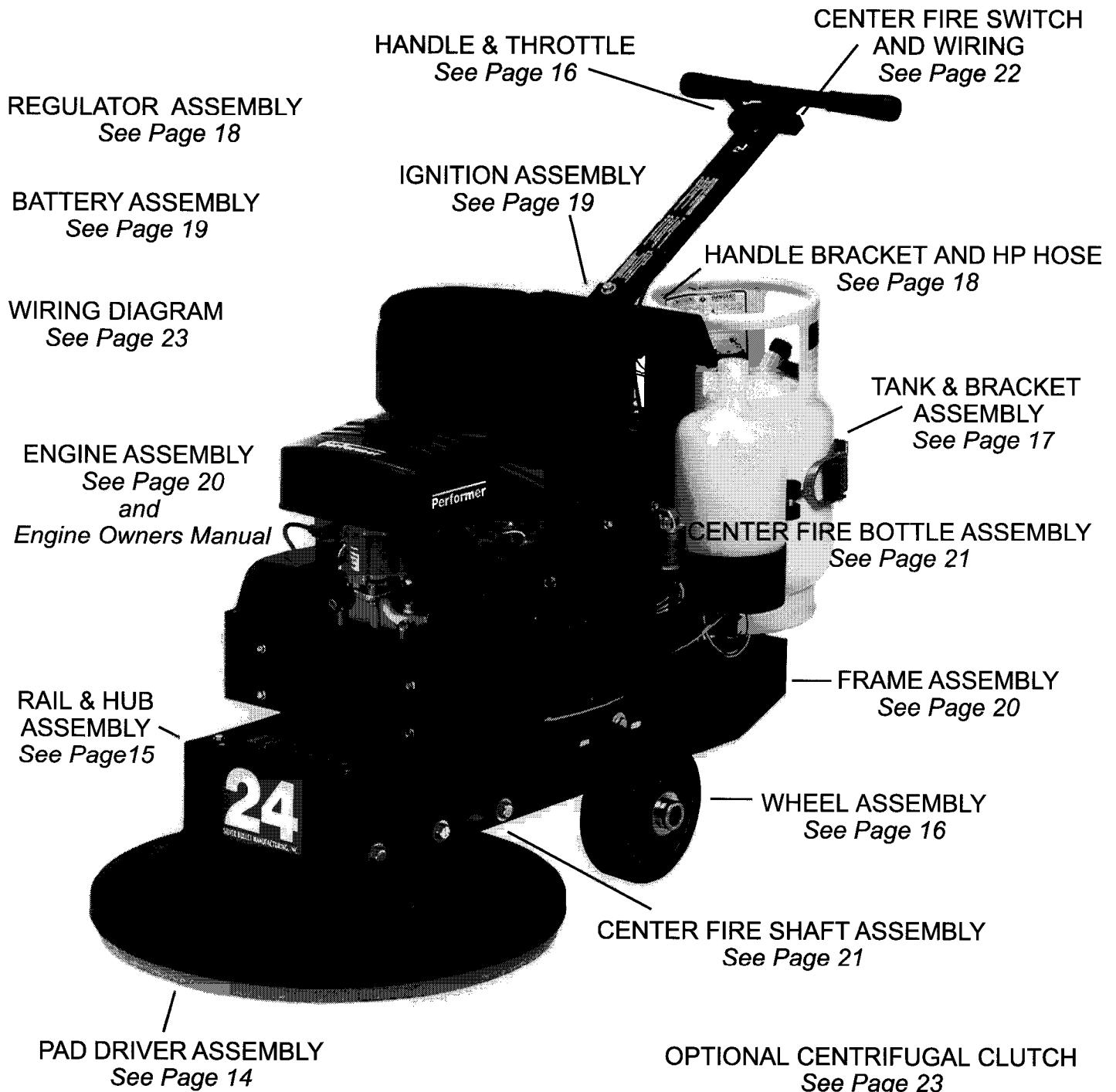

MACHINE DESCRIPTION:

24" Center Fire with 20 HP Onan Engine
27" CenterFire with 20 HP Onan Engine

PART NUMBER:

275440
275450

PAD DRIVER ASSEMBLY

Six (6) Sets:

Screw, 1/4-20x3/4 HH
#W189D

Washer, 1/4 Lock
#980002

Washer, 1/4 Fender
#W311D

Note: Belting is shown flipped.

Pad Driver
24"- #271197
27"- #271198

Three (3) Sets:

Screw, 10-24x1-1/2 RHP
#W384D

Spacer
#271081

Washer, #10 Flat
#W401D

Washer, #10 Spring Lock
#980022

Nut, 10-24 Hex
#W106D

Burnishing Pads
Case of Five
24"- #271159
27"- #271160

Not Shown:

Hood
24"- #271086
27"- #271085

Hood Mounting Sets (4):
Screw, 5/16-18x1/2 HHCS
#962129
Washer, 5/16 Lock
#980006

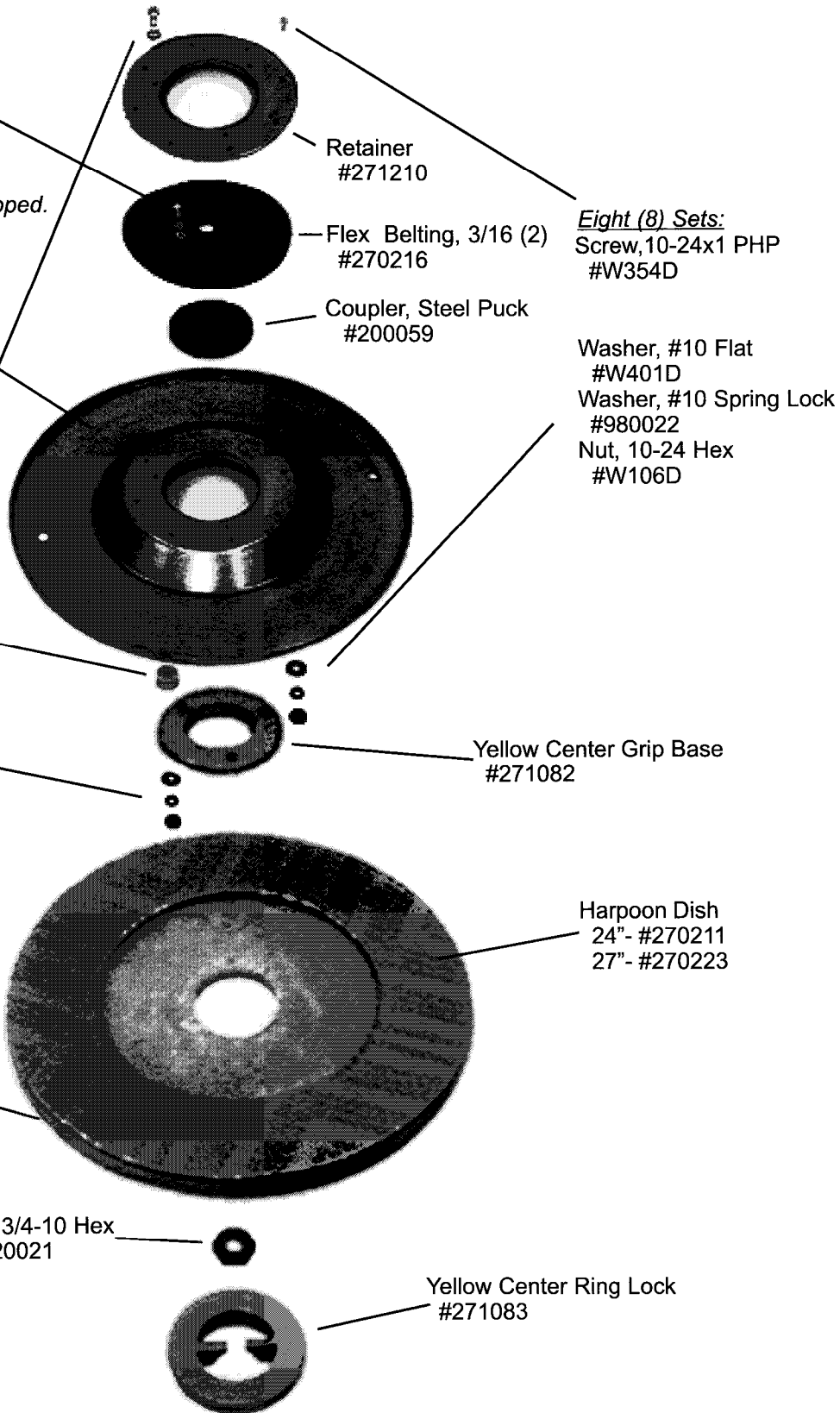

Eight (8) Sets:

Screw, 10-24x1 PHP
#W354D

Washer, #10 Flat
#W401D

Washer, #10 Spring Lock
#980022

Nut, 10-24 Hex
#W106D

Harpoon Dish
24"- #270211
27"- #270223

Yellow Center Grip Base
#271082

Yellow Center Ring Lock
#271083

RAIL & HUB ASSEMBLY

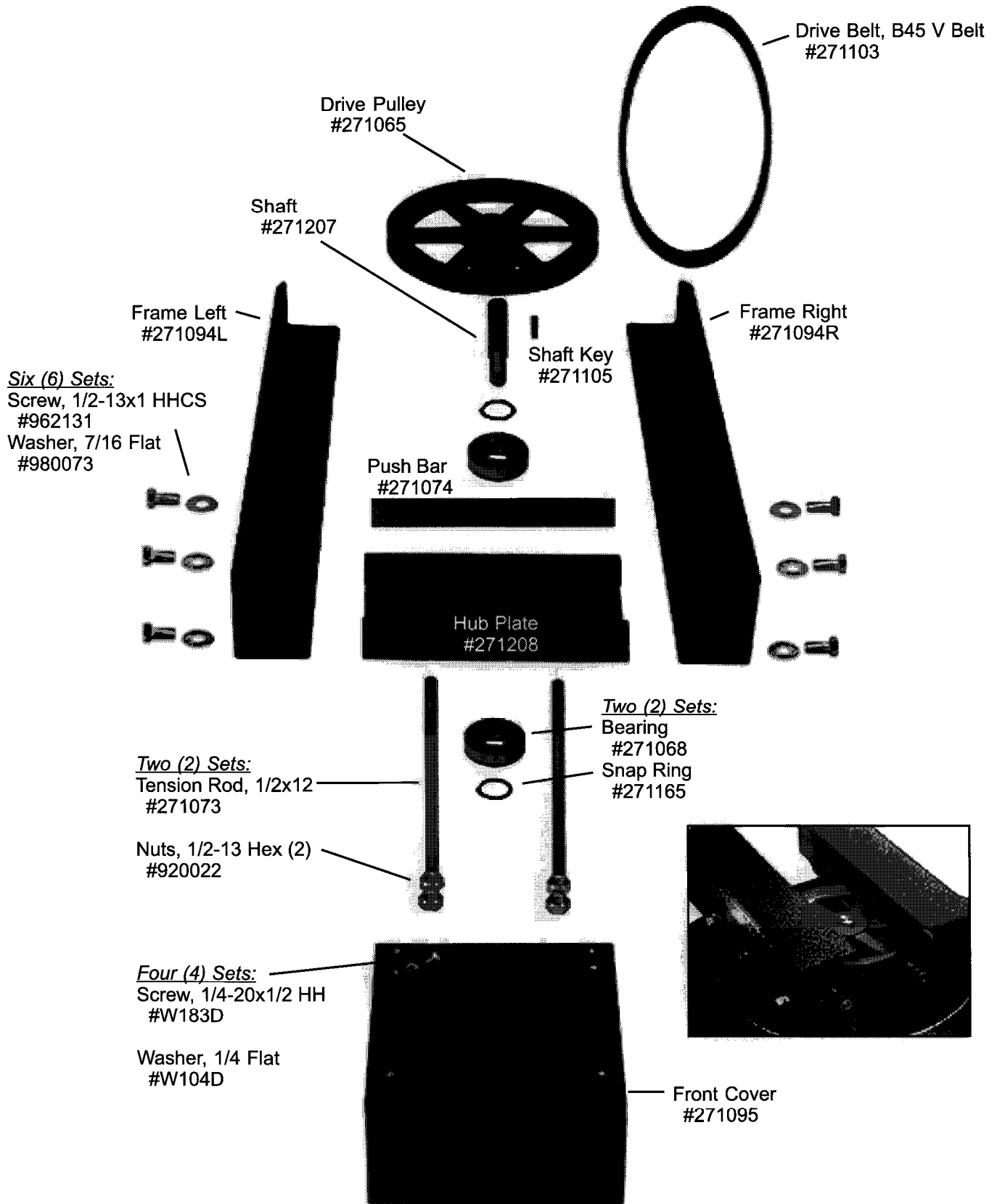

HANDLE & THROTTLE ASSEMBLY

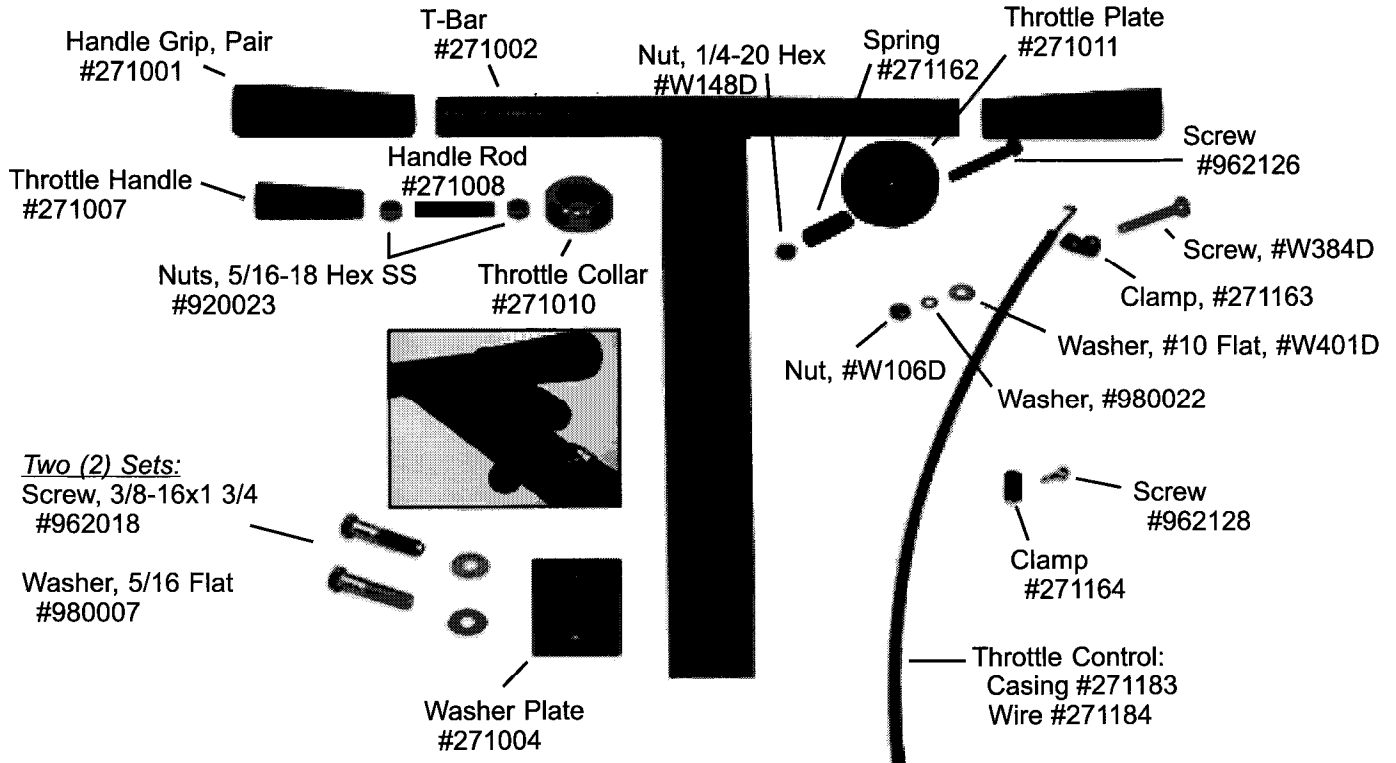

WHEEL ASSEMBLY

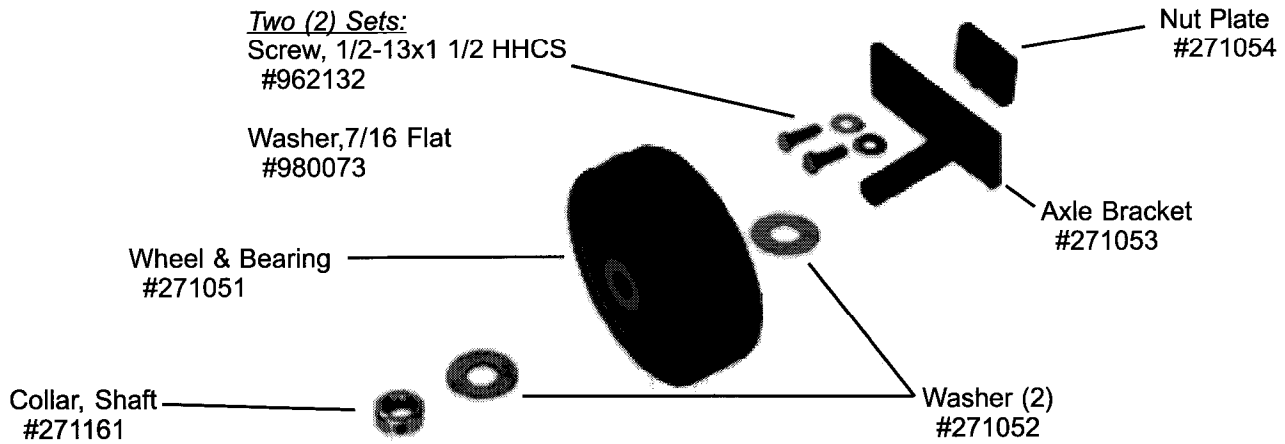

TANK ASSEMBLY

Male Coupler
#271047
(included with tank)

Tank Safety Valve
Part of Tank #271045

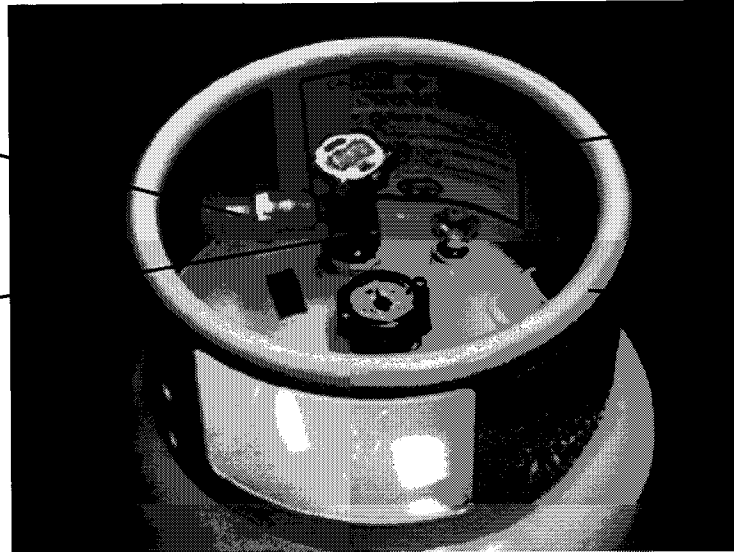

Warning Decal
(not shown)
#271178

LP Tank, 20#
Fittings Included
#271045

BRACKET ASSEMBLY

Tank Bracket
#271030

Bracket Barrel Nut
#271034

Bracket Clasp
#271033

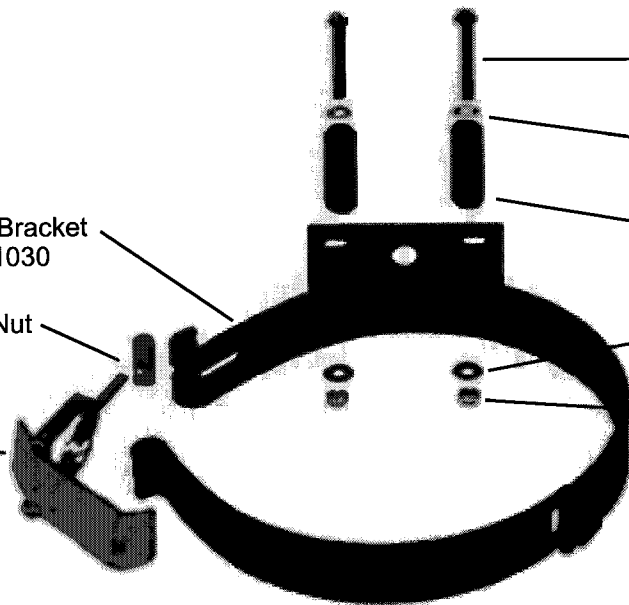

Two (2) Sets:
Bolt, 3/8-16x2 1/4 HH
#962130

Washer, 5/16 Flat
#980007

Bracket Extender Tubes
#271032

Washer, 5/16 Flat
#980007

Nut, 3/8-16 Hex
#920002

Bracket Assembly Complete
#271030

HANDLE BRACKET & HP HOSE ASSEMBLY

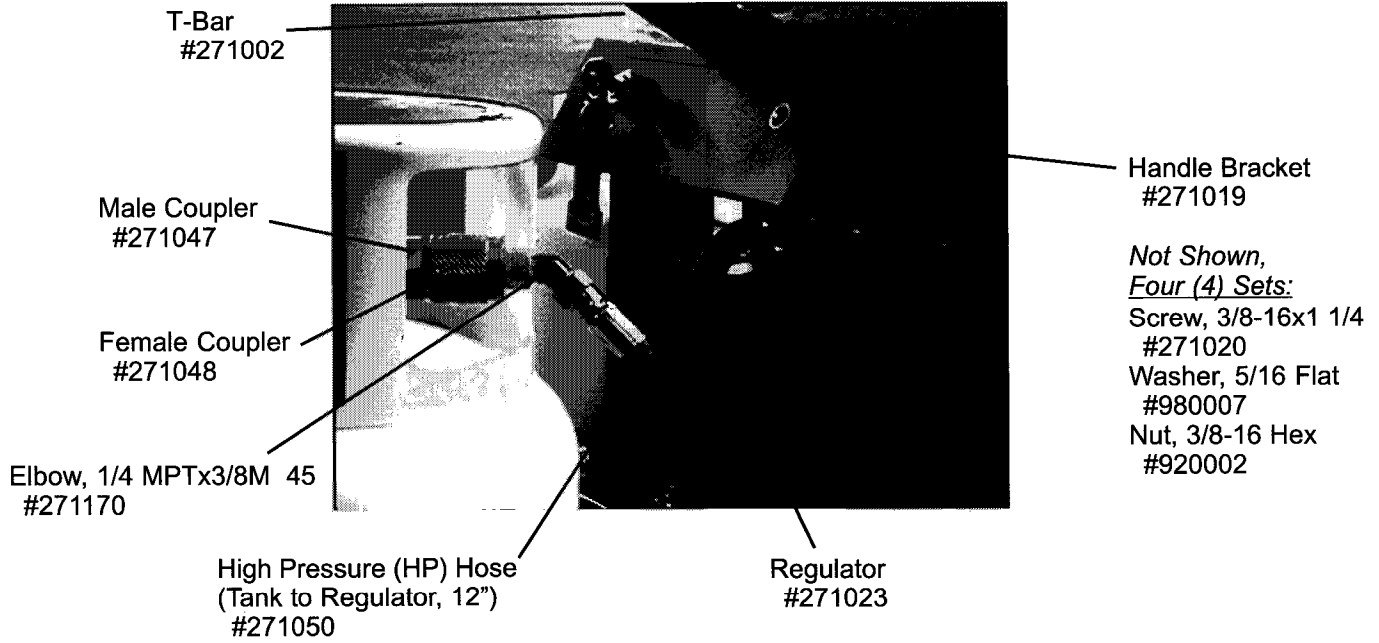

REGULATOR ASSEMBLY

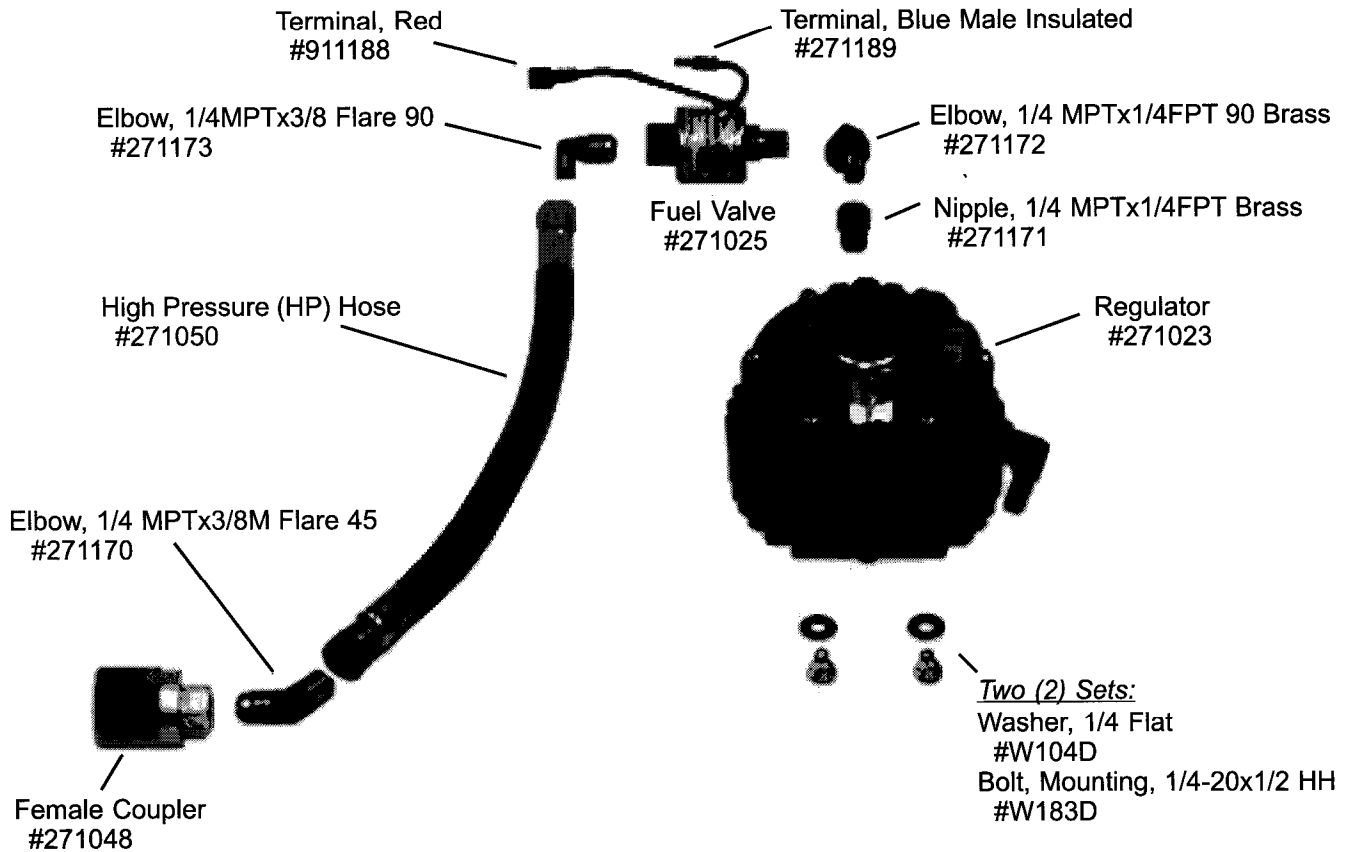

IGNITION ASSEMBLY

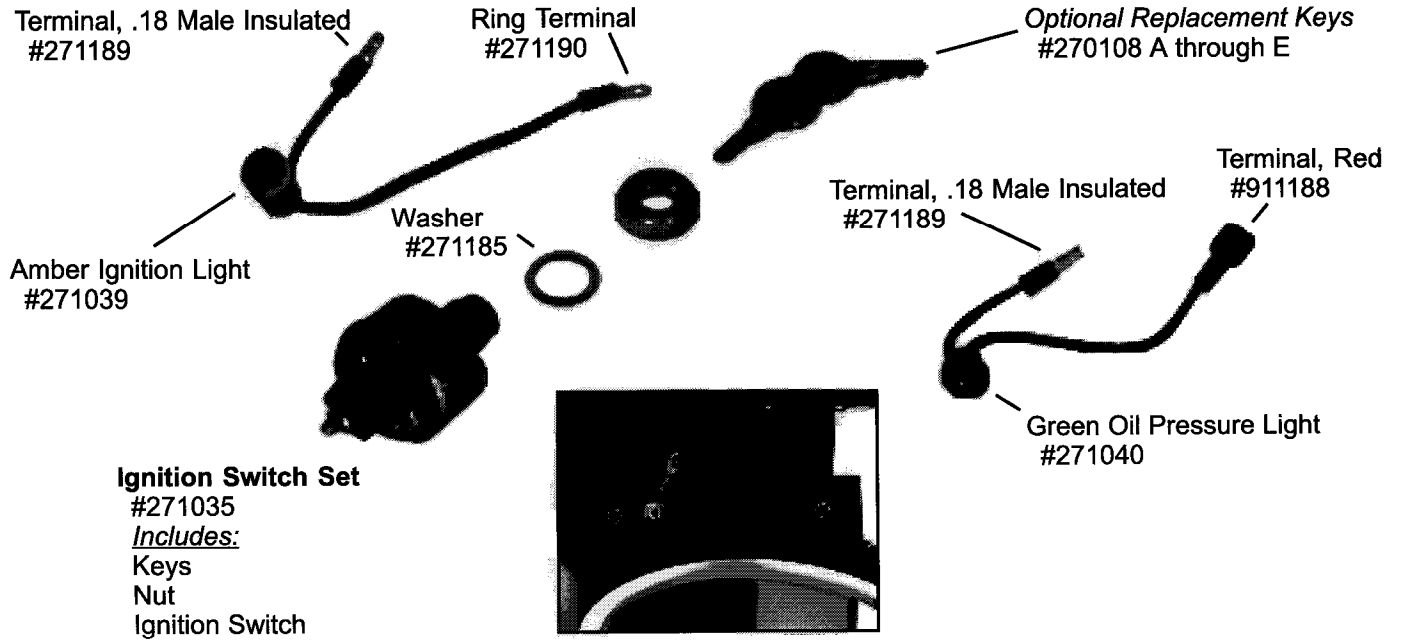

BATTERY ASSEMBLY

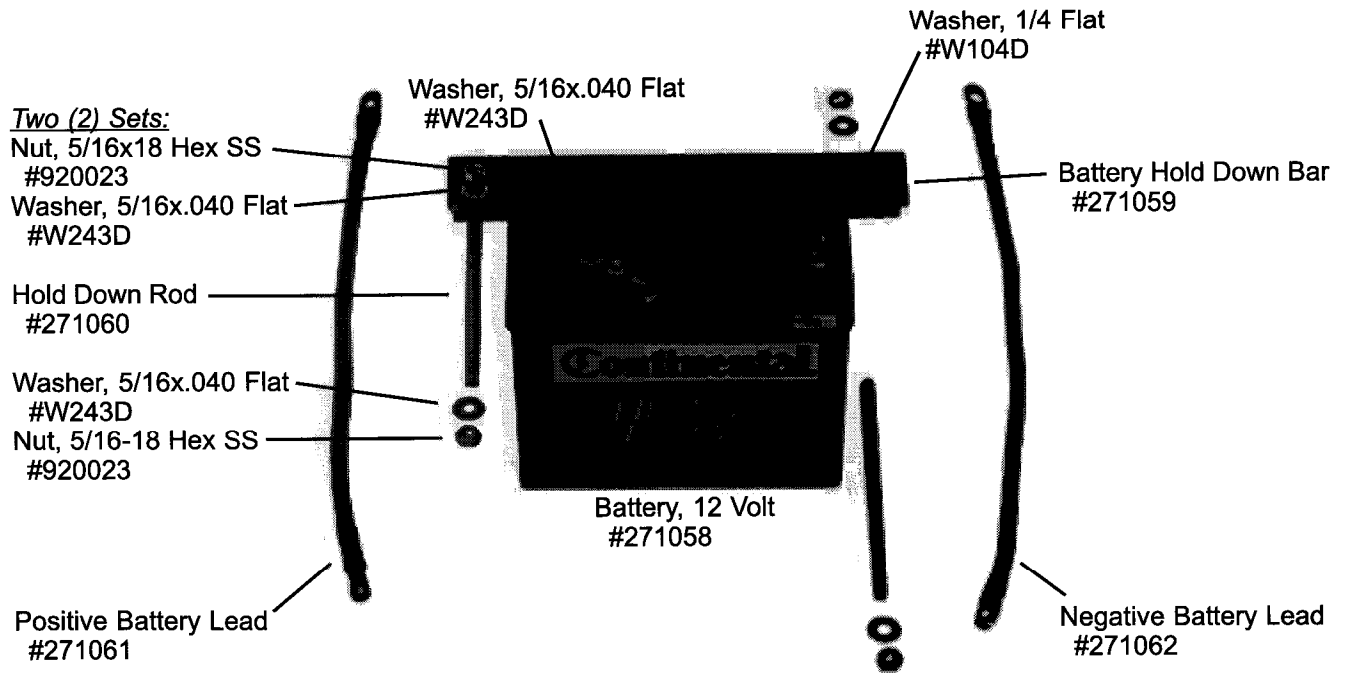

WIRING DIAGRAM - SEE PAGE 23

FRAME ASSEMBLY

Engine Mounting Bolts:

Left Frame
#271094L

Right Frame (Not Shown)
#271094R

Engine Mounting Bolts:

Left Side, Rear Set
Above Frame
Screw, 5/16-18x2HH
#W206D1
Washer, 1/4 Flat
#980004
(Ground Ring and Negative Battery Cable)
Washer, 5/16 Flat
#980007
Below Frame
Washer, 5/16 Flat
#980007
Washer, 1/4 Flat
#980004
Washer, 5/16 Lock
#980006
Nut, 5/16-18 Hex
#920003

Left Side, Front Set :
Above Frame
Screw, 5/16-18x1 1/2 HH
#962049
Below Frame
Washer, 1/4 Flat
#980004
Washer, 5/16 Lock
#980006
Nut, 5/16-18 Hex
#920003

Note: This set also located on Right Frame in both the front & rear

Hour Meter Clasp

Hour Meter
#271099
Meter Leads
1. Positive lead with female terminal 271191 from engine.
2. #271101 negative lead to ground.

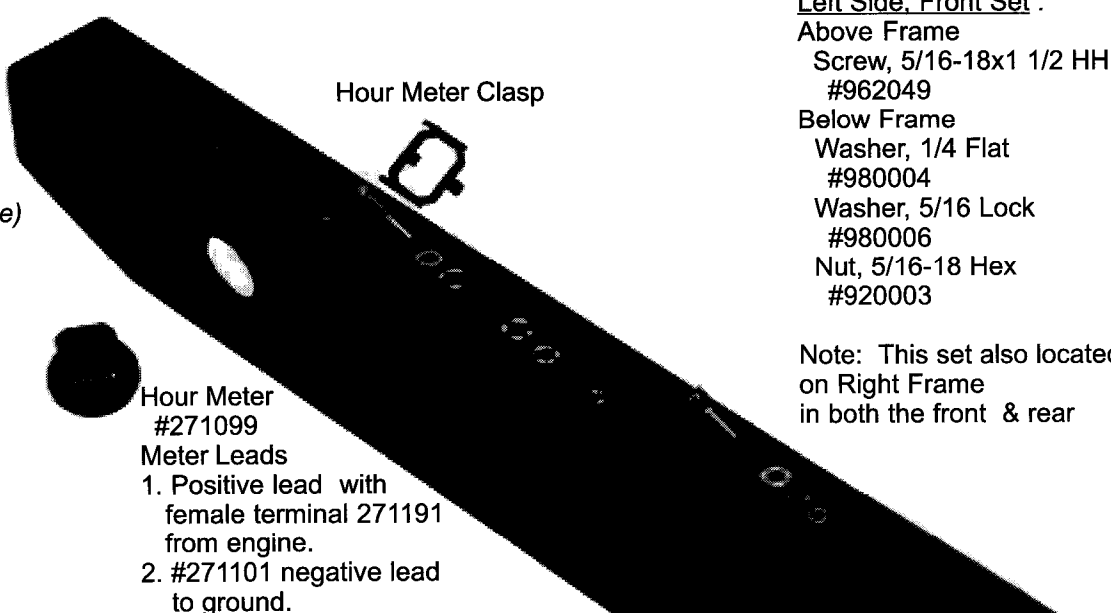

ENGINE

Machine Serial Plate

Oil Filler Tube

Oil Sending Unit (Under Cowling)

Oil Filter #271144

Engine ID Plate

Voltage Regulator

Ring Terminal #271192

Cooling Air Filter #271139

Carburetor Filters Cover
Foam Pre-Filter - #271141
Paper Intake Filter - #271140

Ignition Coil

Carburetor

Muffler Guard

Spark Arrester Screen

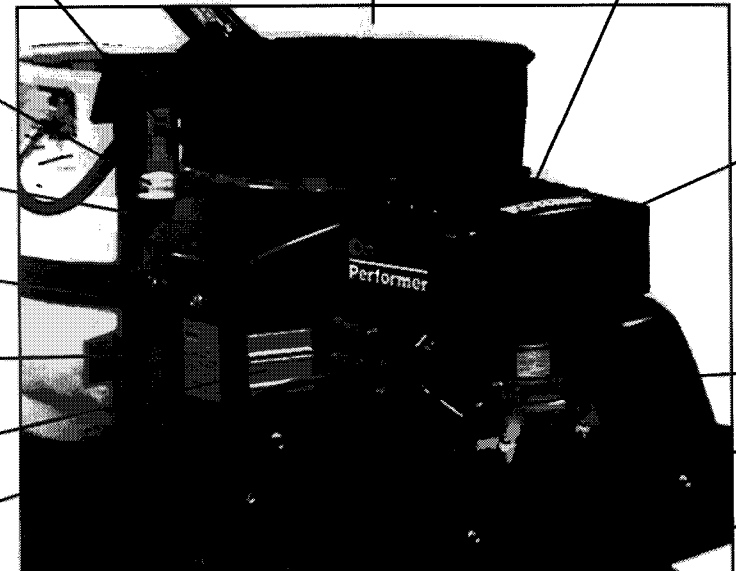

Engine, Onan 20HP, P248V
#272901
Engine w/Regulator
ready to install, #271138
Spark Plug Wire Kit
#271143

Engine Sheave
#271104
Key
#271105

CENTER FIRE BOTTLE ASSEMBLY

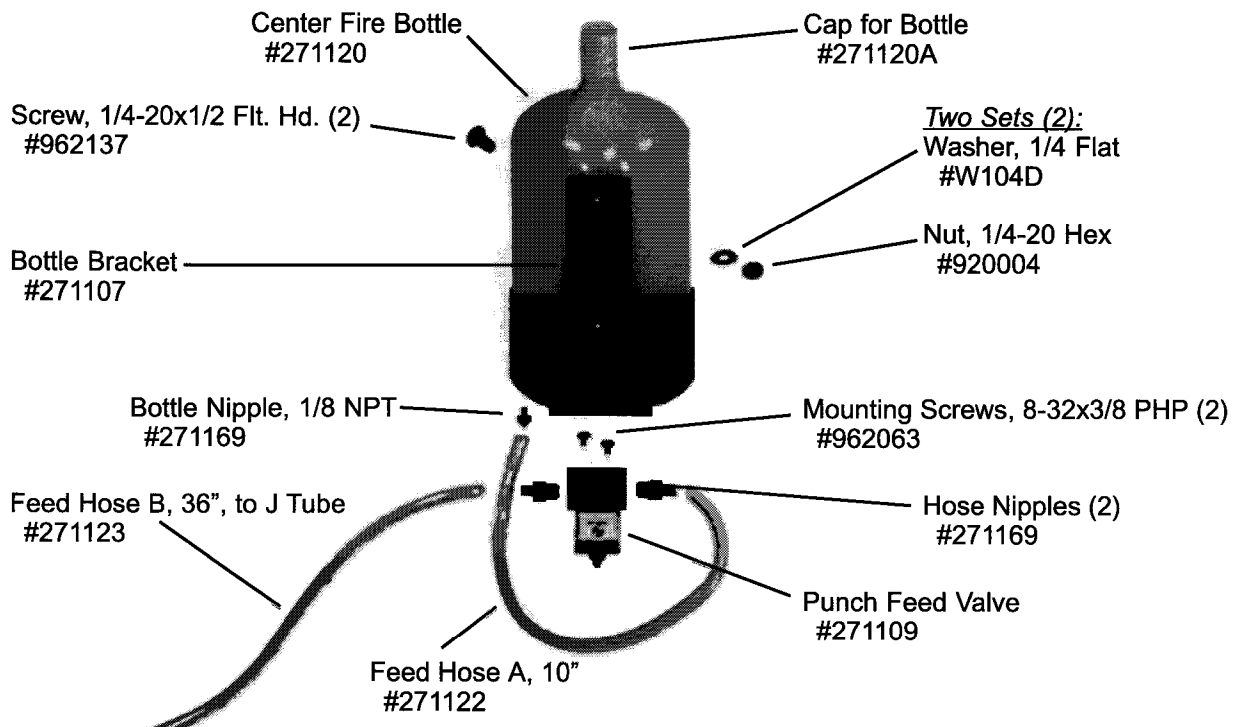

CENTER FIRE SHAFT ASSEMBLY

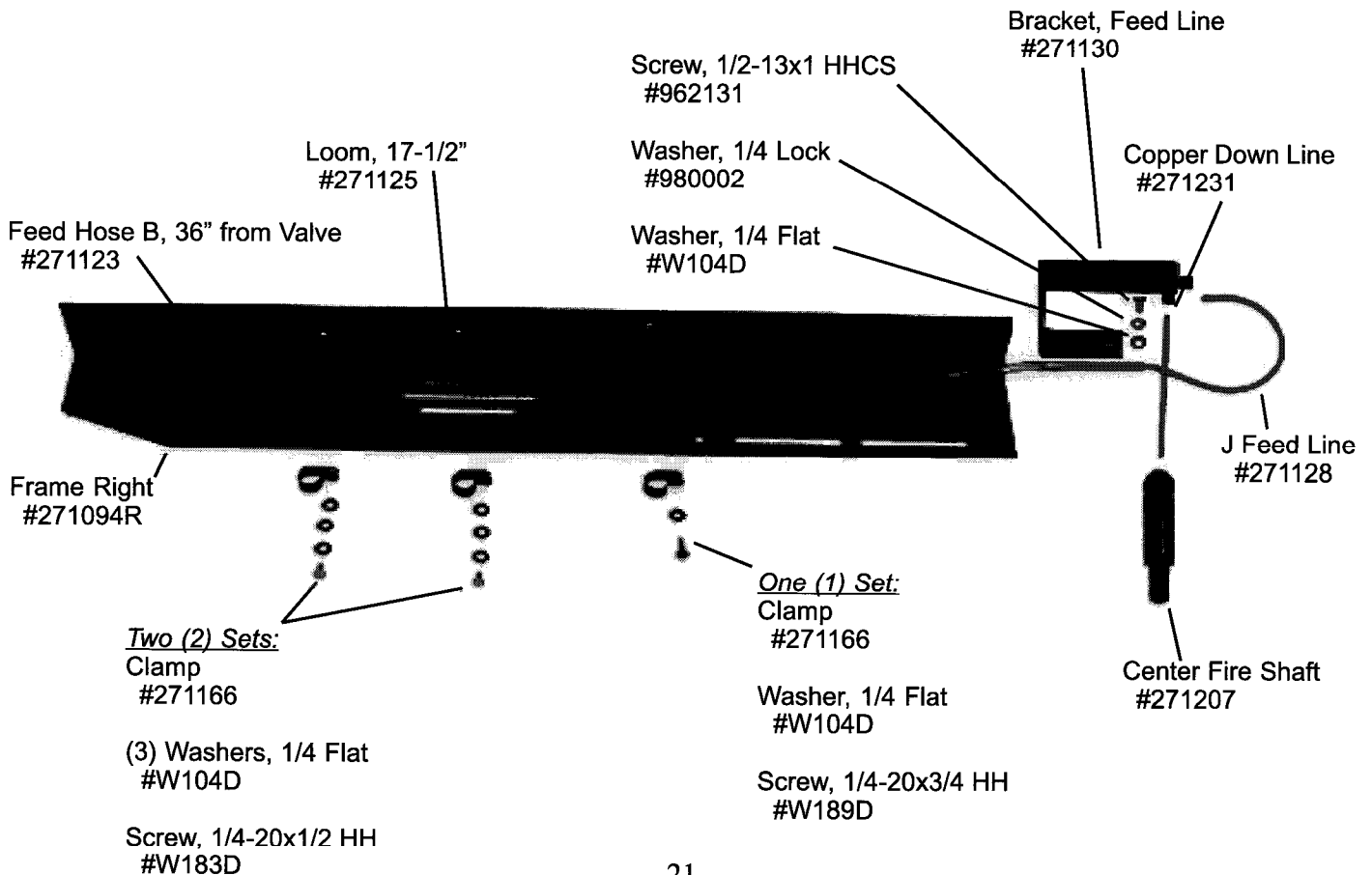

CENTER FIRE SWITCH ASSEMBLY

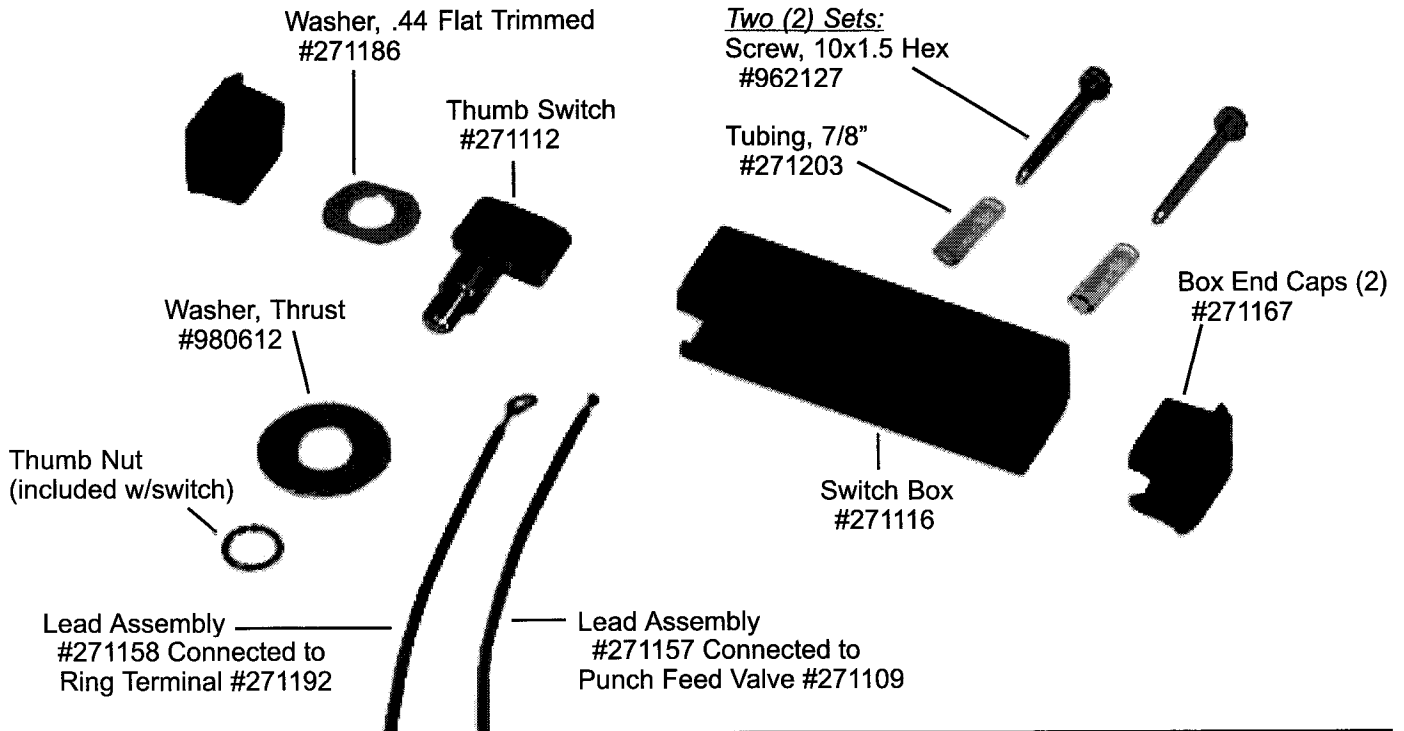

WIRING

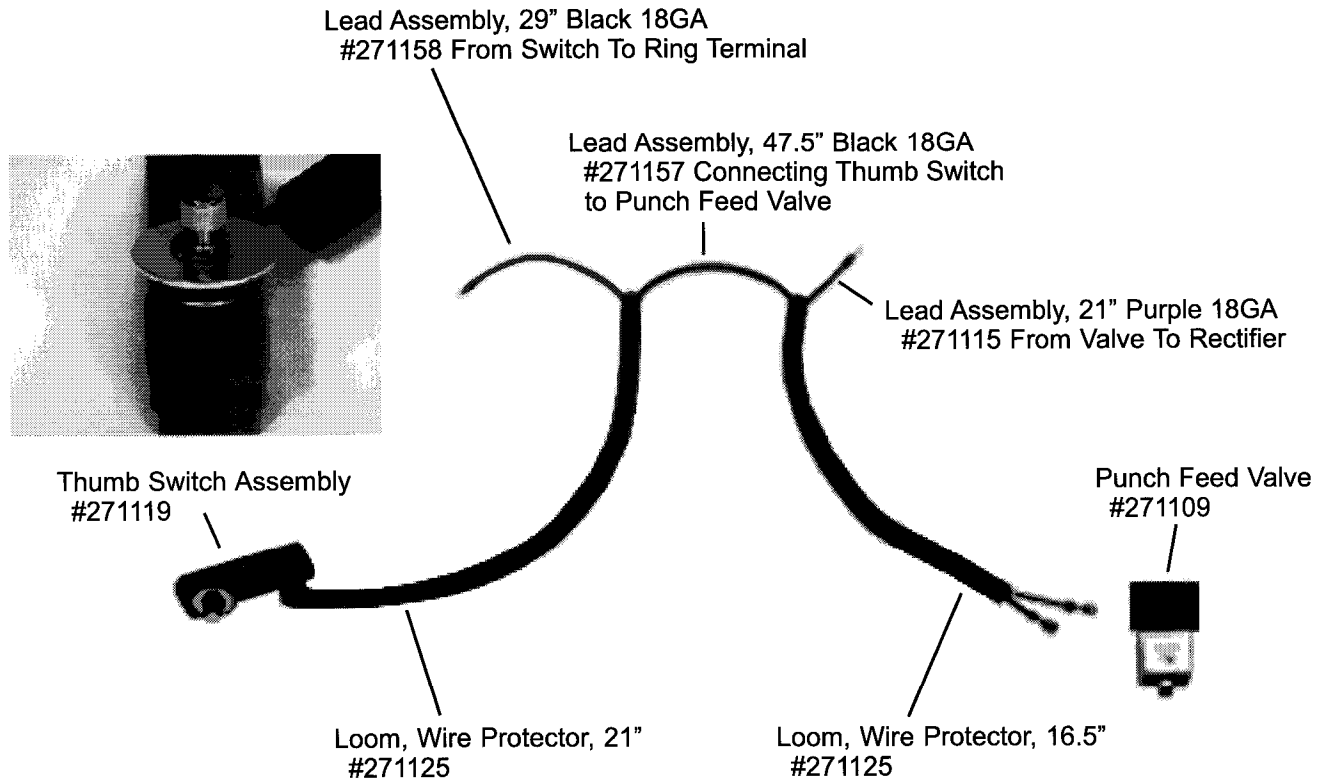

WIRING DIAGRAM

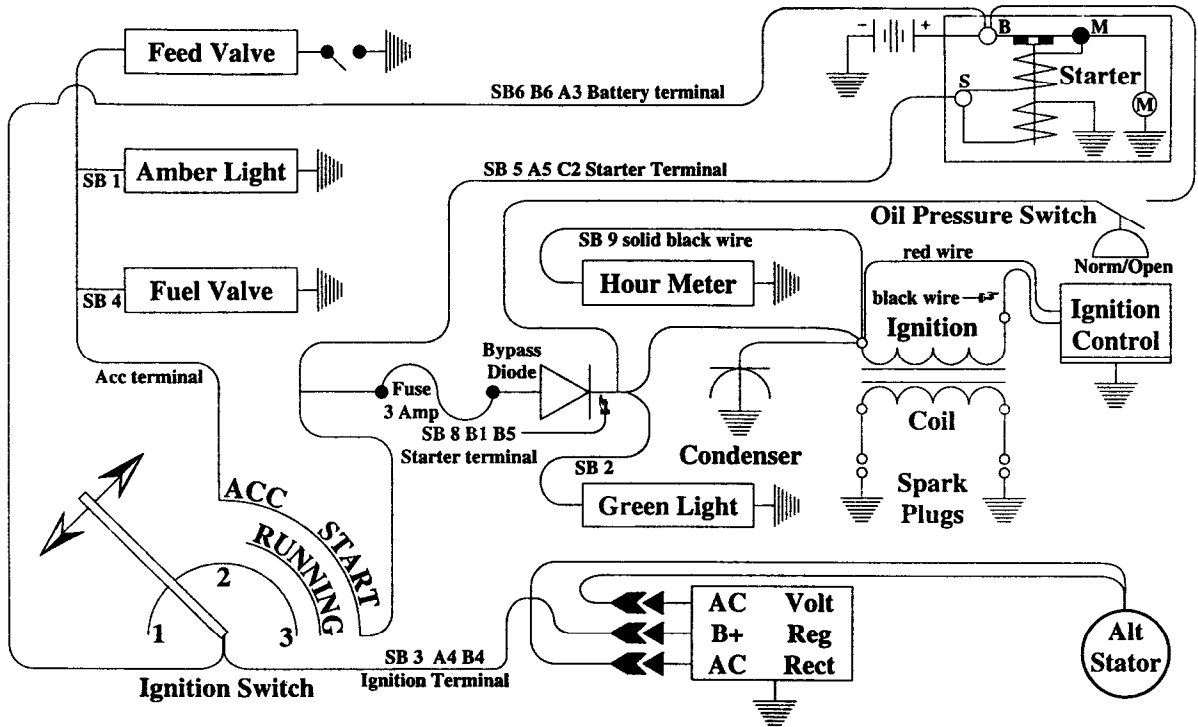

Base Wiring Loop
#271041
Green Light Lead
#271044 (SB2)
Regulator Ignition ACC Lead
#271043 (SB4)

Fused Lead
#271042 (SB8)
Fuse-Buss
#271200

WARRANTY POLICY

PACIFIC STEAMEX INC. LIMITED WARRANTY

The **Pacific Steamex Inc.** Silver Bullet CenterFire has been manufactured, tested and inspected in accordance with specific engineering requirements and is **WARRANTED** to be free from defects in workmanship and materials for periods as follows from the date of purchase

Three (3) years - Onan Engine limited Warranty, Two (2) years on emissions related components, for Engine Warranty Repair refer to the nearest Onan Warranty Service Center.

One (1) year - all other components unless excluded below

This warranty extends to the original user/purchaser and only when used, operated and maintained in accordance with **Pacific Steamex Inc** Operating and Maintenance instructions

This warranty does not apply to the following wear parts and accessories of the machine including

<u>Part Number</u>	<u>Part Name</u>
271159	24" Burnishing Pads
271160	27" Burnishing Pads
271083	Center Ring Lock
270211	24" Harpoon Dish
270223	27" Harpoon Dish
271103	Drive Belt, B-45 V Belt

Warranty credit or replacement of return parts is subject to incoming inspection of those items

To secure repair under this warranty, the following procedure should be taken

- 1 The inoperative machine or warranted parts must be delivered to the authorized dealer with shipping and delivery charges prepaid. If unable to locate the Dealer, you may contact **Pacific Steamex Inc** at the address listed herein for the location of the nearest **Pacific Steamex Inc** repair center or agent or for other instructions pertaining to your warranty difficulty.
- 2 For Engine Warranty repair deliver the machine to the nearest Onan Warranty Service Center. An extended two (2) year warranty is available from Onan within the first twelve months of purchase.
- 3 Upon compliance with the above warranty procedure, all warranted repairs will be completed at no additional charge or cost to the user.
- 4 Only **Pacific Steamex Inc.** or its authorized dealers and agents may make no charge warranty repairs on this product. All others do so at their own risk.

This warranty limits **Pacific Steamex Inc** liability to the repair of the product and/or warranted parts replacement and does not include incidental or consequential damages arising from the use of a **Pacific Steamex Inc** machine whether defective or not.

This warranty is in lieu of all other expressed or implied warranties and is extended to the original purchaser/user.



PACIFIC STEAMEX, INC.
2259 S. SHERIDAN
MUSKEGON, MICHIGAN 49442-6252
1-800-968-1332
FAX 1-800-863-9536