



Electronic Service Manuals

This electronic document is provided as a service to our customers. We do not create the contents of the information contained in this document. Should you have detailed questions pertaining to the information contained in this document, you may contact Michco, or the manufacturer which provided the original information in this electronic deliverable. Michco's only part in this electronic deliverable was the electronic assembly process. By providing this manual on line we are not guaranteeing parts availability.

You may contact Michco through the following methods:

Phone (517) 484-9312 or (800) 331-3339

2011 N. High St. -- Lansing, Michigan -- 48906

Fax: (517) 484-9836

Email: CustServe@Michco.com

Web site: www.Michco.Com

Parts Web site: www.FloorMachineParts.Com

Order Parts on Line at:

www.FloorMachineParts.Com

Directly to Parts & Service:

By Email: **Shop@Michco.com**

By Fax: (517) 702-2041

By Voice: Use numbers above.

Serving the Cleaning Industry Since 1922

Notice: All copyrighted material remains property of original owners, all trademarks are property of respective owners. Manuals are subject to Manufacturer's reproduction limitations. Originals or reproductions were provided by manufacturers through a request. We make no warranty as to the correctness of information provided in this document and you assume all risk. By placing these manuals on line we are not declaring our corporation to be an manufacturer authorized dealer or provider, please check our web site for authorized manufacturers we represent.

Three Speed Air Mover



The contents of this manual are based on the latest product information available at the time of publication. We reserve the right to make changes or improvements to the machine without notice.

This equipment is intended for commercial use only.

Carefully inspect all components to ensure that there is no concealed freight damage. If such damage is discovered, file a "CONCEALED DAMAGE REPORT" immediately with the delivering carrier.

FOR YOUR CONVENIENCE, RECORD THE FOLLOWING IMPORTANT INFORMATION:

SERIAL NUMBER

DATE PURCHASED

READ AND UNDERSTAND ALL WARNINGS AND INSTRUCTIONS BEFORE USING THIS MACHINE!



WARNING! To reduce the risk of fire, electric shock, or injury:

- 1) Read the manual carefully and completely before attempting to operate the unit. This manual has important information for the use and safe operation of the machine. Following the recommendations outlined in this manual will assure years of satisfactory service from your unit.
- 2) Improper connection of the equipment grounding conductor can result in a risk of fire, electrical shock or personal injury. Always use a three-wire electrical system connected to the electrical ground. For maximum protection against electrical shock, use a circuit that is protected by a ground fault circuit interrupter. Check with a qualified electrician or service person if you are in doubt as to whether your outlet is properly grounded. Do not use a unit with a damaged cord or plug.
- 3) Machines can cause an explosion when near flammable materials and vapors. Do not use or store this machine with or near fuels, grain dust, solvents, thinners, or other flammable materials. Do not use flammables to clean this machine.
- 4) Do not immerse or use this unit in standing water. Such use may cause electrical shock. To avoid electrical shock, do not expose the unit to rain – store it indoors only. Do not expose the unit to freezing temperatures.
- 5) Do not move or carry the unit when it is turned on. Do not pull or carry by the cord, use cord as a handle, close a door on the cord or pull cord around sharp edges or corners. Keep cord away from heated surfaces. Do not unplug cord by pulling on it. To unplug, grasp plug, not the cord. Do not handle plug or air mover with wet hands.
- 6) Do not put any objects into openings. Do not use with any opening blocked; keep free of dust, lint, hair and anything that may reduce air flow. Keep hair, loose clothing, fingers and all parts of the body away from openings and moving parts.
- 7) Turn off all controls before unplugging.
- 8) Operate unit on a level and stable surface to prevent it from falling and possible cause of injury or damage.
- 9) Do not drop or throw the unit. Treatment of this type can cause damage to the components and create hazardous conditions.

OPERATION:

Plug your air mover into a standard grounded outlet with the correct voltage and amperage. If you are unsure about the outlet, contact your supervisor. Turn on the switch and check that the unit operates properly before letting it run.

MAINTENANCE:

- Inspect the electrical cord and wiring for damage or discoloration
- Inspect for loose fasteners
- Clean screens on the side and front of the unit
- Listen for abnormal sounds
- Keep unit clean

PERIODIC MAINTENANCE:

Use compressed air or a vacuum to remove lint and other debris from the motor, screen and blower wheel. Do not use a pressure washer to clean the unit.

GROUNDING INSTRUCTIONS:

This machine must be grounded. If it should malfunction or break down, grounding provides a path of least resistance for electric current to reduce the risk of electric shock. This machine is equipped with a cord having an equipment-grounding conductor and grounding plug. The plug must be inserted into an appropriate outlet that is properly installed and grounded in accordance with all local codes and ordinances.



WARNING! - Improper connection of the equipment-grounding conductor can result in a risk of electric shock. Check with a qualified electrician or service person if you are in doubt as to whether the outlet is properly grounded. Do not modify the plug provided with the machine - if it will not fit the outlet; have a proper outlet installed by a qualified electrician.

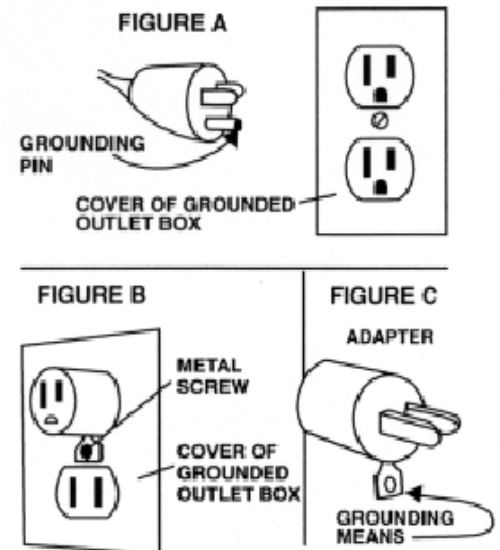

This machine is for use on a nominal 120-volt circuit, and has a grounded plug that looks like the plug illustrated in figure A. A temporary adapter that looks like the adapter illustrated in figures B and C may be used to connect this plug to a 2-pole receptacle as shown in figure B if a properly grounded outlet is not available. The temporary adapter should be used only until a properly grounded outlet (figure A) can be installed by a qualified electrician. The green colored rigid ear, lug, or the like extending from the adapter must be connected to a permanent ground such as a properly grounded outlet box cover. Whenever the adapter is used, it must be held in place by a metal screw. This machine is designed to operate on a standard 15 amp, 115 Volt, 60 Hz, AC circuit. Voltages below 105 volts AC or above 125 volts AC could cause serious damage to the motor.

NOTE: In Canada, the use of a temporary adapter is not permitted by the Canadian Electrical Code

EXTENSION CORDS:

Use only three-wire 16/3 or larger gauge approved extension cords that have three-prong grounding type plugs and three-pole receptacles that accept the appliance's plug. Replace or repair any damaged cords or plugs.



WARNING! - For the safe operation of this machine follow the instructions given in this booklet and the training given by your supervisor. Failure to do so can result in personal injury and/or damage to machine and property!

DO NOT OPERATE MACHINE IN AN EXPLOSIVE ENVIRONMENT!

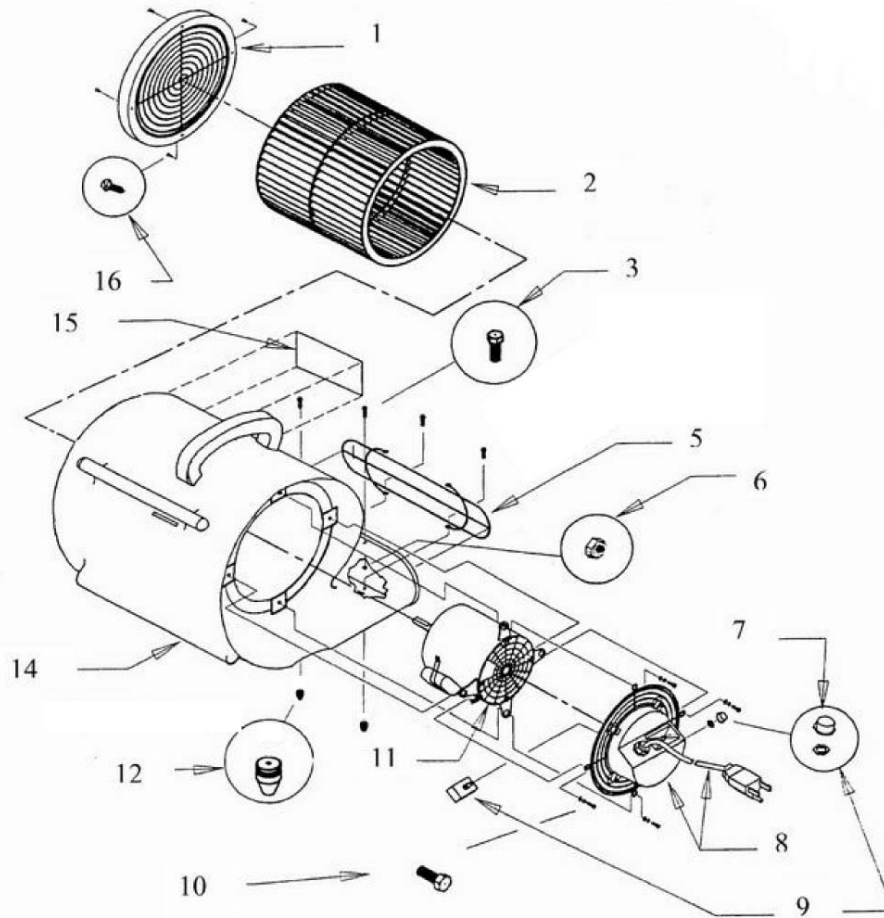

Item	Part #	Description	Qty Req.	Item	Part #	Description	Qty Req.
1	233601	Guard, Fan Side	1	10	962068	Bolt - Flange 1/4-20x5/8	4
2	233090	Blower Wheel	1	11	235202	Motor-1/2 HP	1
3	930014	Rivet		12	233801	Grommet-Rubber	2
5	233602	Front Guard	1	14	234240	Housing - Blower	1
7	235045	Knob	1	15		Label	1
8	233603	Guard, Black Cord	1	16	962200	Screw - 8-15x5/8	4
9	238002	Switch - 4-Position	1				

WARRANTY:

1-year warranty on complete unit. When servicing, use an authorized person only. Use only identical replacement parts. To prevent electrical shock: Always remove the electrical plug from the electrical outlet before performing any repairs, maintenance or cleanup.