



Electronic Service Manuals

This electronic document is provided as a service to our customers. We do not create the contents of the information contained in this document. Should you have detailed questions pertaining to the information contained in this document, you may contact Michco, or the manufacturer which provided the original information in this electronic deliverable. Michco's only part in this electronic deliverable was the electronic assembly process. By providing this manual on line we are not guaranteeing parts availability.

You may contact Michco through the following methods:

Phone (517) 484-9312 or (800) 331-3339

2011 N. High St. -- Lansing, Michigan -- 48906

Fax: (517) 484-9836

Email: CustServe@Michco.com

Web site: www.Michco.Com

Parts Web site: www.FloorMachineParts.Com

Order Parts on Line at:

www.FloorMachineParts.Com

Directly to Parts & Service:

By Email: **Shop@Michco.com**

By Fax: (517) 702-2041

By Voice: Use numbers above.

Serving the Cleaning Industry Since 1922

Notice: All copyrighted material remains property of original owners, all trademarks are property of respective owners. Manuals are subject to Manufacturer's reproduction limitations. Originals or reproductions were provided by manufacturers through a request. We make no warranty as to the correctness of information provided in this document and you assume all risk. By placing these manuals on line we are not declaring our corporation to be an manufacturer authorized dealer or provider, please check our web site for authorized manufacturers we represent.

Proteus 26 & 26BA

Parts List

PACIFIC

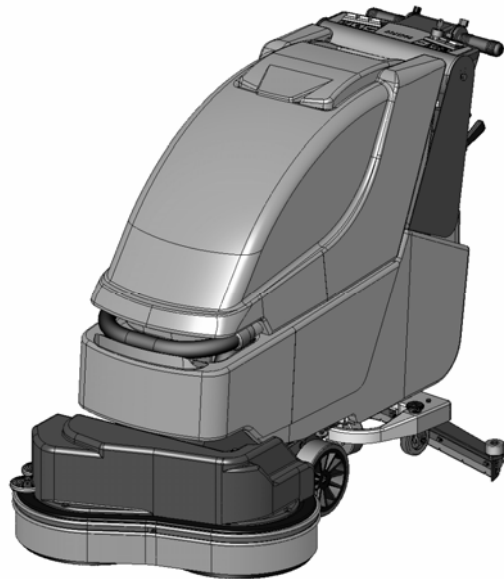

The contents of this manual are based on the latest product information available at the time of publication. Pacific reserves the right to make changes or improvements to its machines without notice.

Carefully inspect all components to ensure that there is no concealed freight damage. If such damage is discovered, file a "CONCEALED DAMAGE REPORT" immediately with the delivering carrier.

FOR YOUR CONVENIENCE, RECORD THE FOLLOWING IMPORTANT INFORMATION:

For new manuals write to:

Pacific
2259 S. Sheridan
Muskegon, MI 49442-6252

SERIAL NUMBER

DATE PURCHASED

or download the most recent version of the manuals from our website:

www.pacificfloorcare.com

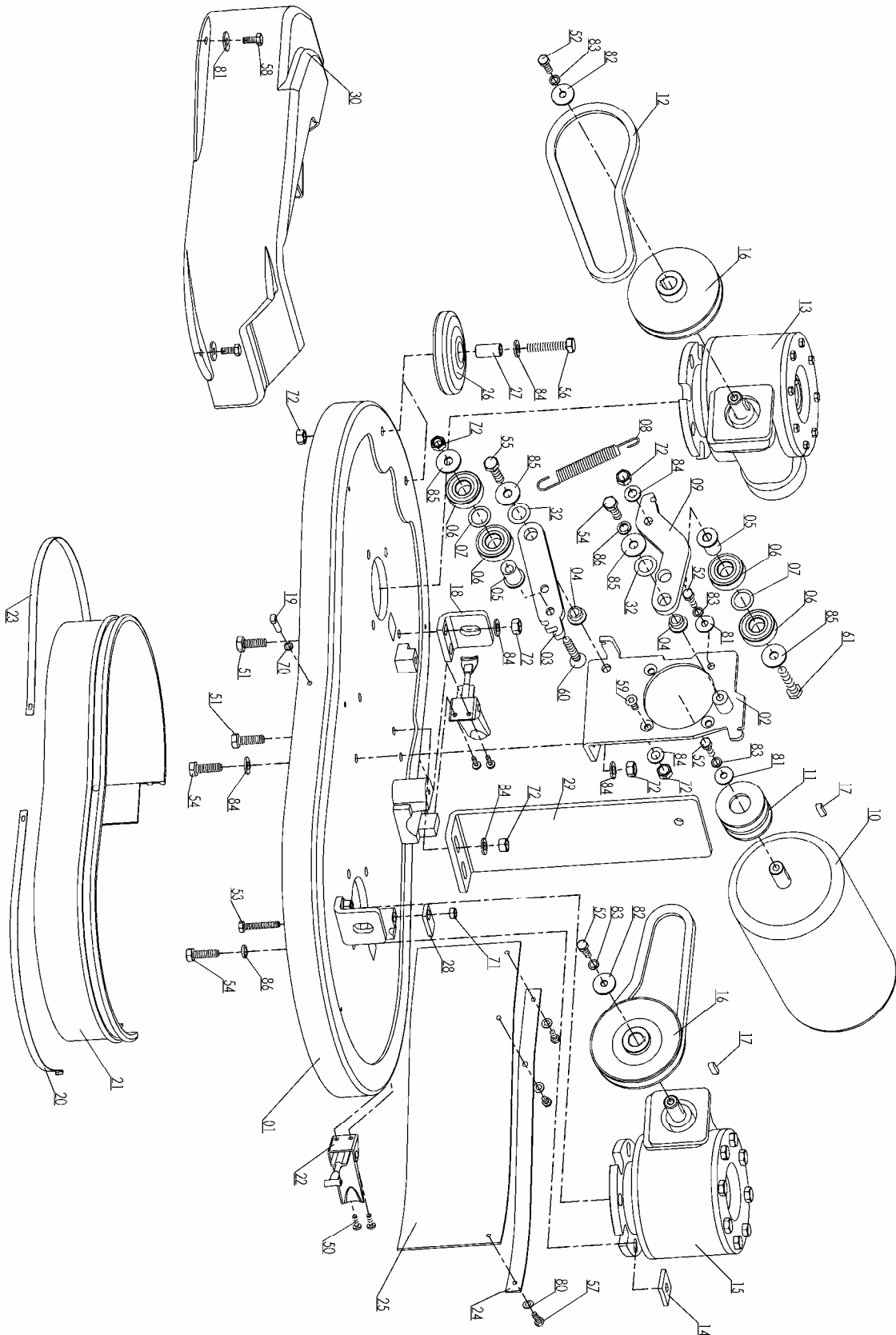



PACIFIC

BRUSH HEAD ASSEMBLY for PROTEUS 26		
Item	Part number	Description
1	861312	BRUSH BASE
2	40701310	MOTOR SUPPORT
3	40701320	TENSIONER
4	69106020	BUSHING
5	69106150	BUSHING
6	902032	BEARING
7	71222002	SHIM
8	69220540	SPRING
9	40701330	TENSIONER
10	865206	BRUSH MOTOR
11	69410280	PULLEY
12	903029	V-BELT
13	68600010	REDUCTION GEAR ASSEMBLY
14	40301170	PLATE
15	68600020	REDUCTION GEAR INVERTED
16	69410270	PULLEY
17	885030	KEY
18	868522	SUPPORT
19	40301120	SPECIAL SCREW
20	860704	BLADE
21	67607040	SPLASH GUARD
22	74400002	HOOK ASSEMBLY
23	40701190	BLADE
24	40701200	BLADE
25	863601	SPLASH GUARD
26	67020030	WHEEL
27	69102110	BUSHING
28	40228500	BLADE
29	868523	SUPPORT
30	862305	BASE COVER
32	71222001	SHIM
50	70910412	SCREW
51	70910806	SCREW
52	964116	SCREW
53	964095	SCREW
54	964090	SCREW
55	964085	SCREW
56	964103	SCREW
57	964133	SCREW
58	70940604	SCREW
59	70980602	SCREW
60	70980812	SCREW
61	964106	SCREW
70	924057	NUT
71	924026	LOCK NUT
72	924033	LOCK NUT
80	980066	WASHER
81	980040	WASHER
82	980065	WASHER
83	71106009	LOCK WASHER
84	980039	WASHER
85	980044	WASHER
86	980069	LOCK WASHER



BRUSH HEAD ASSEMBLY for PROTEUS 26BA		
Item	Part number	Description
1	861312	BRUSH BASE
2	40701310	MOTOR SUPPORT
3	40701320	BELT TENSIONER ARM
4	69106020	BUSHING
5	69106150	BUSHING
6	902032	BEARING
7	71222002	SHIM
8	69220540	SPRING
9	40701330	BELT TENSIONER ARM
10	865206	BRUSH MOTOR
11	69410280	PULLEY
12	903029	V-BELT
13	68600010	REDUCTION GEAR ASSEMBLY
14	40301170	PLATE
15	68600020	REDUCTION GEAR ASSEMBLY
16	69410270	PULLEY
17	885030	KEY
18	868522	SUPPORT
19	40301120	SPECIAL SCREW
20	860704	CLAMP BLADE
21	67607040	SPLASH GUARD
22	74400002	HOOK ASSEMBLY
23	40701190	CLAMP BLADE
24	40701200	CLAMP BLADE
25	863601	SPLASH GUARD
26	67020030	WHEEL
27	69102110	BUSHING
28	40228500	CLAMP
29	868523	SUPPORT
30	862305	BASE COVER
32	71222001	SHIM
33	868514	GEAR BOX ANGLED SHIM
50	70910412	SCREW
51	70910806	SCREW
52	964116	SCREW
53	964095	SCREW
54	964090	SCREW
55	964085	SCREW
56	964103	SCREW
57	964133	SCREW
58	70940604	SCREW
59	70980602	SCREW
60	70980812	SCREW
61	964106	SCREW
70	924057	NUT
71	924026	LOCK NUT
72	924033	LOCK NUT
80	980066	WASHER
81	980040	WASHER
82	980065	WASHER
83	71106009	LOCK WASHER
84	980039	WASHER
85	980044	WASHER
86	980069	LOCK WASHER



PACIFIC

BRUSH CONTROL ASSEMBLY		
Item	Part number	Description
1	865111	LEVER
2	964170	SCREW
3	964171	SCREW
4	70944801	SCREW
5	867501	BUSHING
6	868524	SUPPORT
7	869232	TIE ROD
8	860305	ROCKER ARM
9	74620001	PIN
10	867404	TIE ROD
11	74610001	CONNECTOR FORK
12	74610004	CONNECTOR FORK
13	74100007	KNOB
14	865112	LEVER
15	888336	SPRING
16	980039	WASHER
17	861103	BUSHING
18	924067	NUT
19	964196	SCREW
20	70910620	SCREW
21	964106	SCREW
22	74620007	SCREW
23	74610005	CONNECTOR FORK
24	74620006	PIN
25	868525	SUPPORT
26	868526	SUPPORT
27	866705	CLEVIS PIN
28	863303	CONNECTOR FORK
49	925610	ROLL PIN
50	71010809	NUT
51	924033	LOCK NUT
52	980069	LOCK WASHER
53	964197	SCREW
54	980040	WASHER
55	920646	LOCK NUT
56	980663	WASHER
57	980070	WASHER
58	964107	SCREW
59	70980809	SCREW
60	980050	LOCK WASHER
63	980650	RETAINING RING
83	861104	WASHER
84	861105	BUSHING
85	867705	SHAFT
86	860306	ROCKER ARM
87	861106	BUSHING
88	925611	COTTER PIN

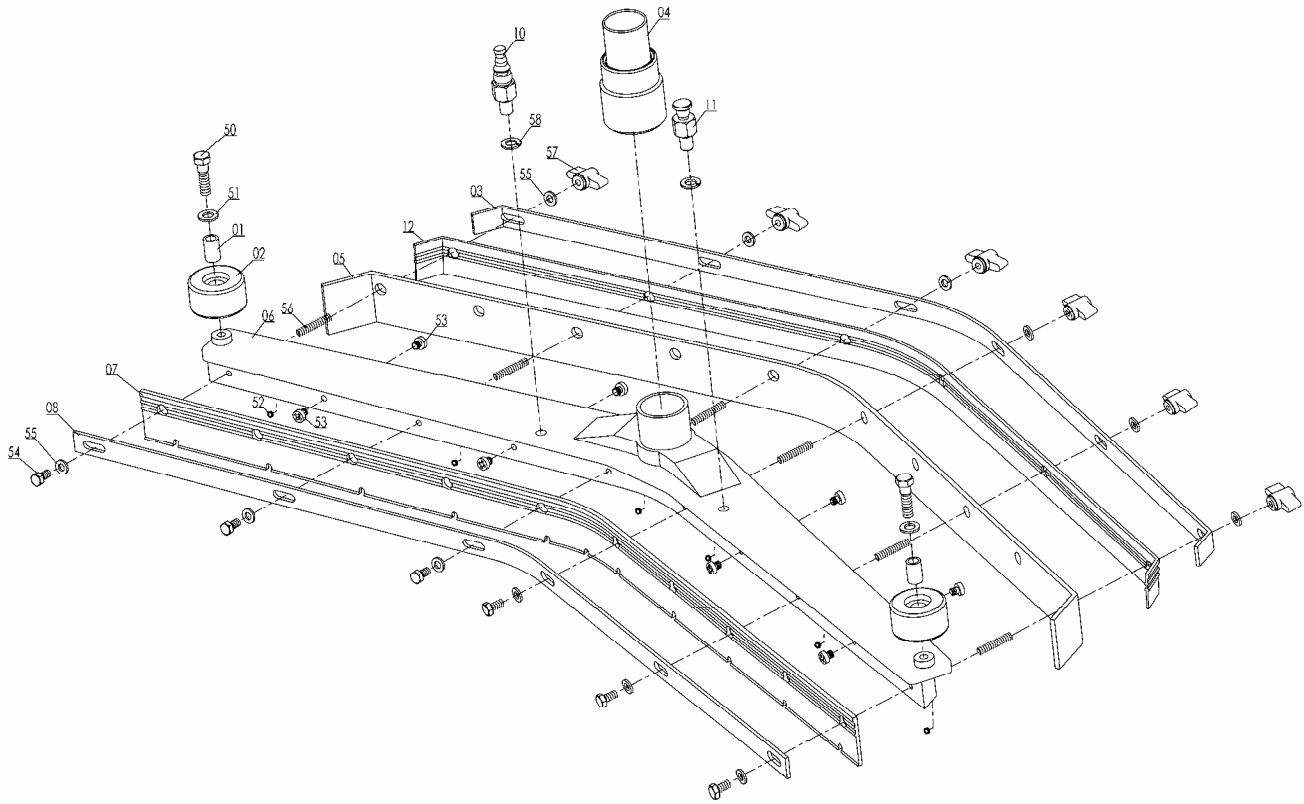

SQUEEGEE ASSEMBLY		
Item	Part number	Description
1	881145	BUSHING
2	889742	WHEEL
3	867201	CLAMP BLADE
4	67512690	VACUUM HOSE
5	860705	CENTRAL RUBBER BLADE
6	861313	SQUEEGEE BODY
7	860706	FRONT RUBBER BLADE
8	867202	CLAMP BLADE
10	867012	POST
11	867013	POST
12	860707	REAR RUBBER BLADE
50	964085	SCREW
51	980039	WASHER
52	924050	NUT
53	964174	SCREW
54	964175	SCREW
55	980651	WASHER
56	964176	SCREW
57	74008011	WING NUT
58	980652	LOCK WASHER
59	71108007	WASHER
	868528	Complete squeegee asm. 34.5" includes all parts noted except item 4



Squeegee Assembly (30 Inch Optional)

Drawing 5

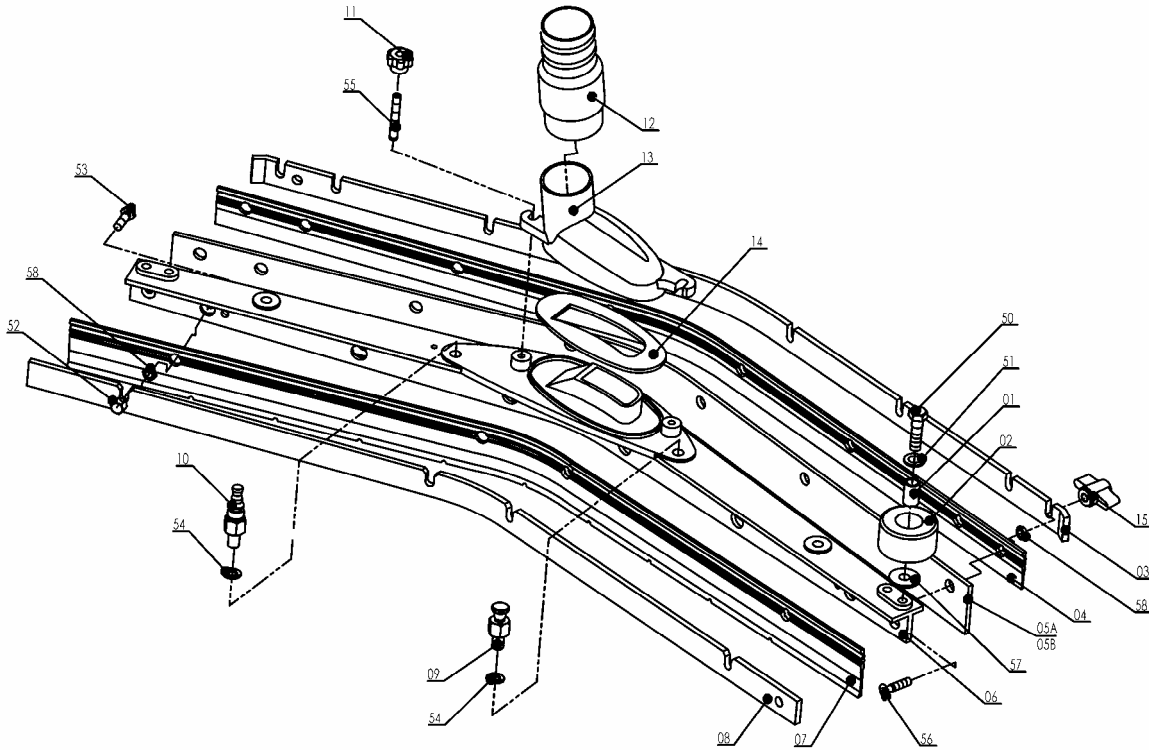

SQUEEGEE ASSEMBLY (30" OPTIONAL)		
Item	Part number	Description
1	881145	BUSHING
2	889742	BUMPER WHEEL
3	68813020	CLAMP BLADE
4	880750	REAR RUBBER BLADE
5A	880751	CENTRAL RUBBER BLADE
5B	880752	CENTRAL RUBBER BLADE (40 DR)
6	69623010	SQUEEGEE BODY
7	880753	FRONT RUBBER BLADE
8	68813010	CLAMP BLADE
9	42311030	POST
10	42311010	POST
11	74006010	KNOB
12	67512620	VACUUM HOSE
13	880240	VACCUUM PORT
14	67406100	GASKET
15	74006011	WING NUT
50	964085	BOLT
51	980039	WASHER
52	924050	NUT
53	964109	BOLT
54	924061	LOCK WASHER
55	925606	SCREW
56	964110	SCREW
57	980044	WASHER
58	924054	NUT

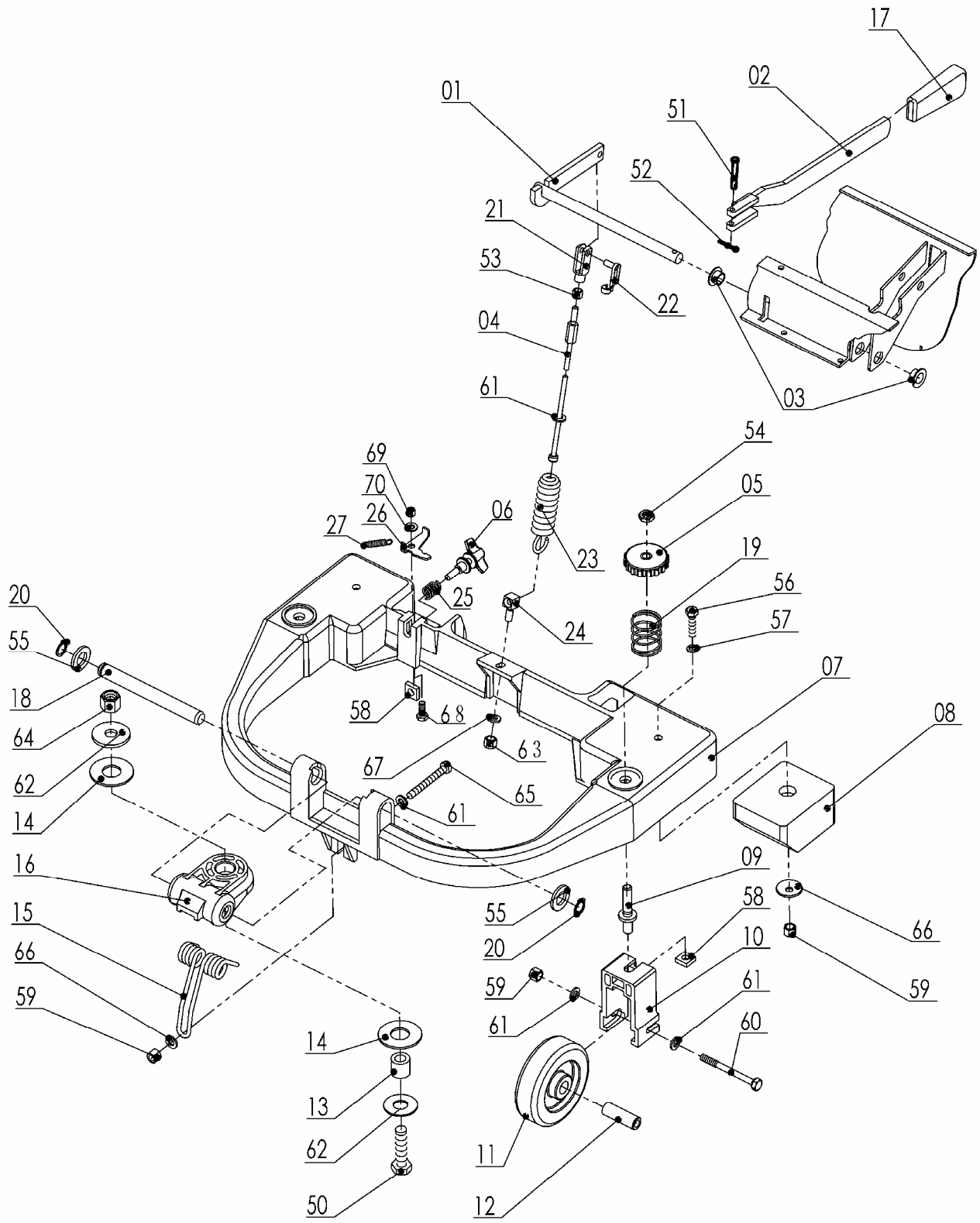



PACIFIC

SQUEEGEE CONTROL ASSEMBLY		
Item	Part number	Description
1	42312050	LEVER
2	42312070	LEVER
3	69122010	BUSHING
4	74803062	CABLE
5	40212010	HAND WHEEL
6	880551	ADJUSTER
7	42312040	ARM
8	42312080	BALLAST
9	42312060	PIN
10	42312030	SUPPORT
11	869707	WHEEL
12	69122020	BUSHING
13	69122040	BUSHING
14	41312080	SPECIAL WASHER
15	69230020	SPRING
16	42312010	COUPLING
17	74100005	KNOB
18	42312020	PIN
19	69210330	SPRING
20	70220003	RETAINING RING
21	74610007	CONNECTOR FORK
22	74620008	CLIP
23	69220190	SPRING
24	42312100	COUPLING
25	69210660	SPRING
26	42312140	COUPLER
27	69220560	SPRING
50	70911009	BOLT
51	866706	CLEVIS PIN
52	925612	COTTER PIN
53	924060	NUT
54	71010809	NUT
55	980046	WASHER
56	70910621	BOLT
57	71106009	LOCK WASHER
58	71010810	NUT
59	924026	LOCK NUT
60	70910627	BOLT
61	980042	WASHER
62	980064	WASHER
63	924050	LOCK NUT
64	924055	LOCK NUT
65	70910621	BOLT
66	980065	WASHER
67	980040	WASHER
68	964186	BOLT
69	920644	LOCK NUT
70	980660	WASHER



Frame & Tank Assembly

Drawing 7

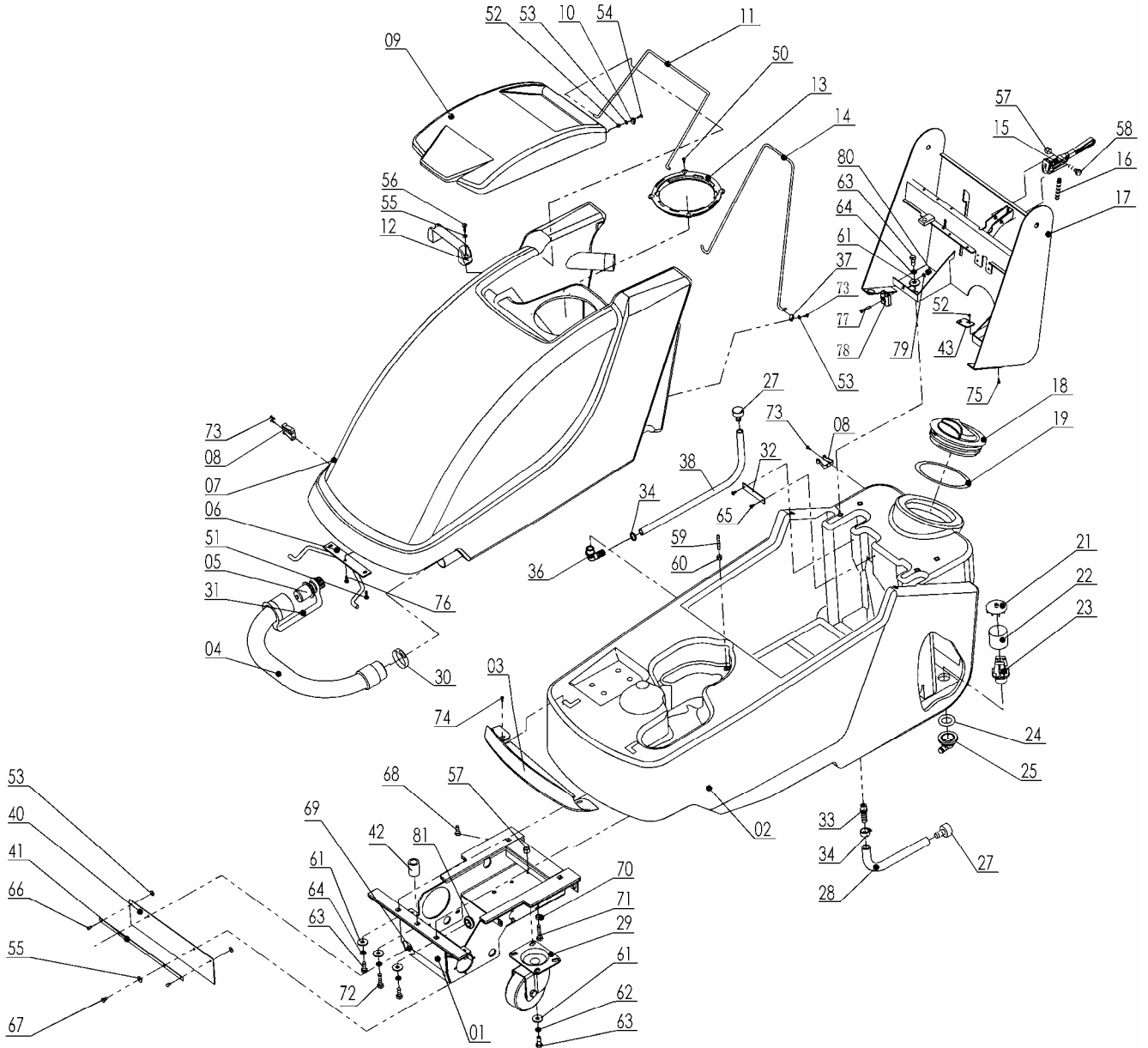



PACIFIC

FRAME & TANK ASSEMBLY		
Item	Part number	Description
1	863205	FRAME
2	69723030	SOLUTION TANK
3	862304	COVER
4	67512580	DRAIN HOSE
5	886842	PLUG
6	42336080	HINGE
7	69723020	RECOVERY TANK
8	882440	HOOK
9	862303	COVER
10	72902008	CABLE FASTENER
11	42346010	HINGE
12	883930	HANDLE
13	42036030	FILTER SUPPORT
14	42336030	PROP
15	885143	LEVER
16	888344	SPRING
17	863204	FRAME
18	886844	COVER
19	883444	GASKET
21	882331	COVER
22	883331	FILTER
23	883332	BASE
24	70800003	O-RING
25	74520025	RING NUT
27	886852	CAP
28	67521670	PIPE
29	869708	CASTOR
30	S611A	HOSE CLAMP
31	42341010	STRAP
32	42336090	GUIDE
33	74540002	CONNECTOR
34	S453P	HOSE CLAMP
36	74520004	ELBOW PIPE FITTING
37	862104	CABLE FASTENER
38	67523260	HOSE
40	42346090	SPLASH GUARD
41	42346100	BLADE
42	861107	BUSHING
43	868527	SUPPORT
50	964188	SCREW
51	964189	SCREW
52	924029	LOCK NUT
53	71104002	WASHER
54	70950401	SCREW
55	980066	WASHER
56	70944807	SCREW
57	924033	LOCK NUT
58	964103	SCREW
59	925606	SCREW
60	924048	NUT
61	980039	WASHER
62	980053	WASHER
63	70930808	SCREW
64	980069	LOCK NUT
65	70944203	SCREW
66	71400004	RIVET
67	964084	SCREW
68	964187	SCREW
69	71050503	NUT
70	924069	NUT
71	964170	SCREW
72	964178	SCREW
73	70973902	SCREW
74	964196	SCREW
75	964179	SCREW
76	964190	SCREW
77	964191	SCREW
78	911418	CONNECTOR
79	980662	WASHER
80	920645	NUT
81	883841	FAIRLEAD

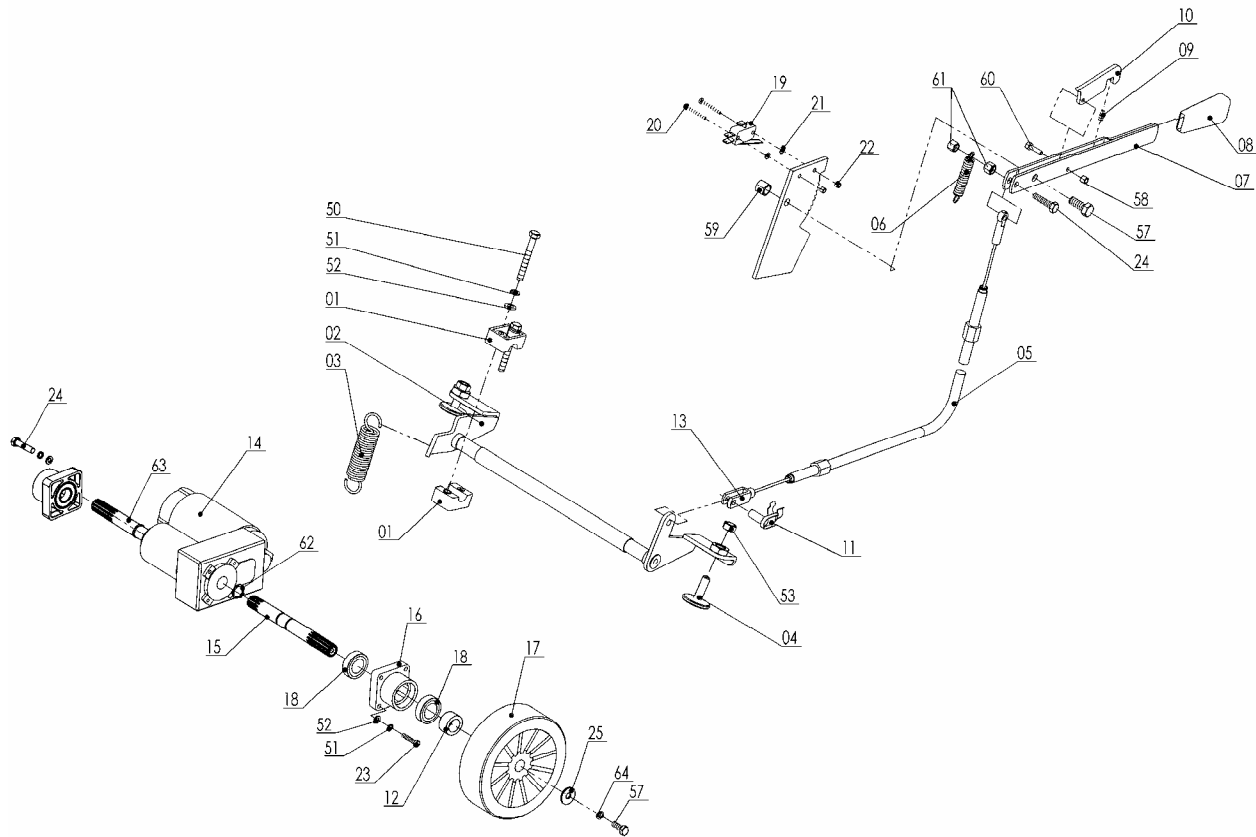

BRAKE and TRACTION ASM for PROTEUS 26

Item	Part number	Description	Item	Part number	Description
1	882043	PIVOT BLOCK	19	72105009	SNAP ACTION SWITCH
2	42318010	SHAFT ASSEMBLY	20	70940304	SCREW
3	69220160	SPRING	21	980054	WASHER
4	41318090	PAD	22	924043	LOCK NUT
5	74803051	BRAKE CABLE	23	964083	SCREW
6	888336	SPRING	24	964197	SCREW
7	40318100	LEVER	25	980660	WASHER
8	74100005	KNOB	50	964079	SCREW
9	69210540	SPRING	51	71106009	LOCK WASHER
10	40318110	LEVER	52	980042	WASHER
11	74620005	PIN	53	71010809	NUT
12	69022020	BUSHING	57	964086	SCREW
13	74610004	CONNECTOR FORK	58	924029	LOCK NUT
14	865205	GEAR MOTOR	59	924033	LOCK NUT
15	867706	AXLE SHAFT - LEFT	60	70910407	SCREW
16	42317010	BEARING SEAT	61	924050	LOCK NUT
17	67030570	WHEEL	62	70220016	RETAINING RING
18	70512002	BEARING	63	867708	AXLE SHAFT - RIGHT

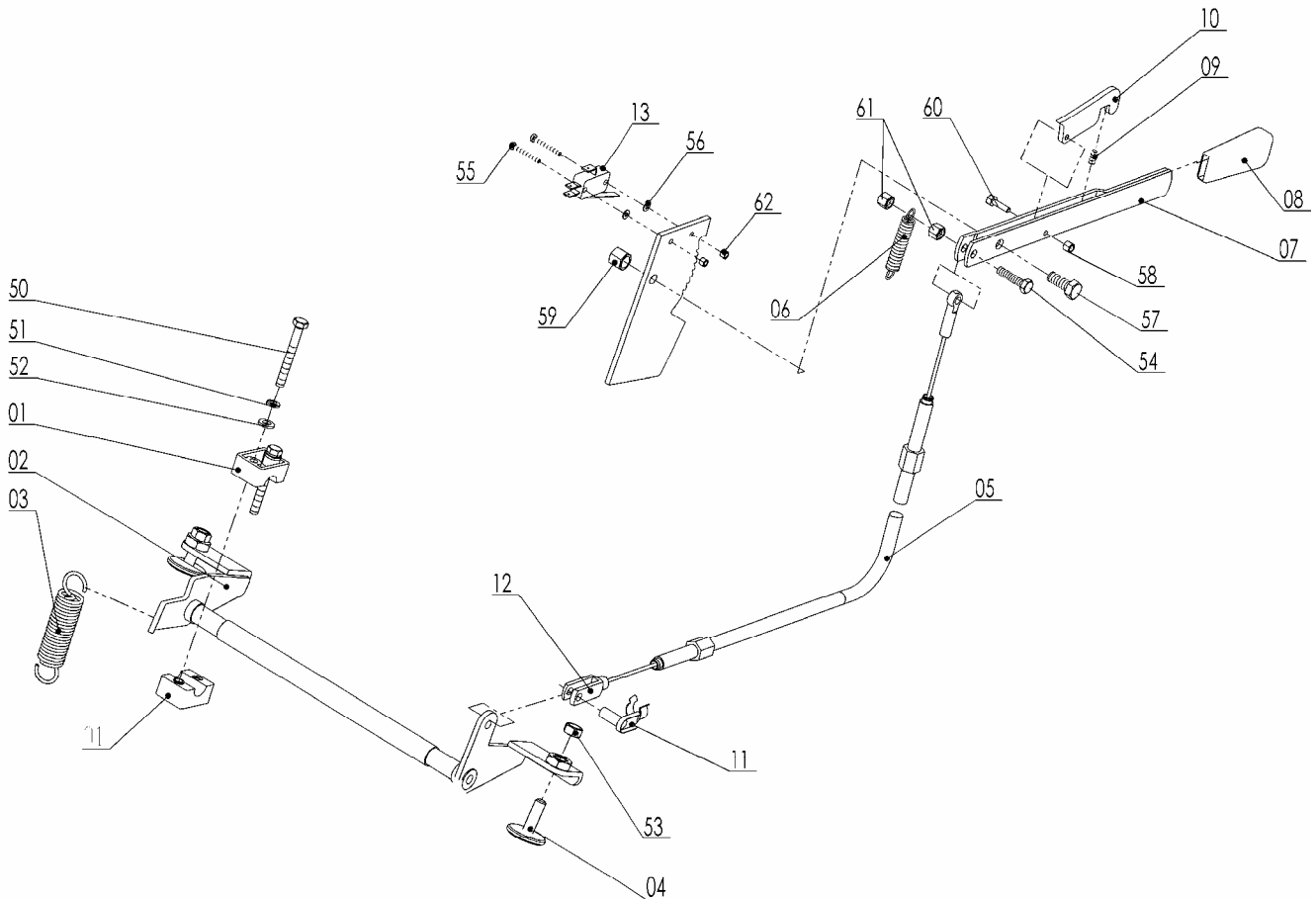

BRAKE ASSEMBLY for PROTEUS 26BA						
Item	Part number	Description	Item	Part number	Description	
1	882043	PIVOT BLOCK	50	964079	SCREW	
2	42318010	SHAFT ASSEMBLY	51	71106009	LOCK WASHER	
3	69220160	SPRING	52	980042	WASHER	
4	41318090	PAD	53	71010809	NUT	
5	74803051	BRAKE CABLE	54	964083	SCREW	
6	888336	SPRING	55	70940304	SCREW	
7	40318100	LEVER	56	980054	WASHER	
8	74100005	KNOB	57	964086	SCREW	
9	69210540	SPRING	58	924029	LOCK NUT	
10	40318110	LEVER	59	924033	LOCK NUT	
11	74620005	PIN	60	70910407	SCREW	
12	74610004	CONNECTOR FORK	61	924050	LOCK NUT	
13	72105009	SNAP ACTION SWITCH	62	924043	LOCK NUT	

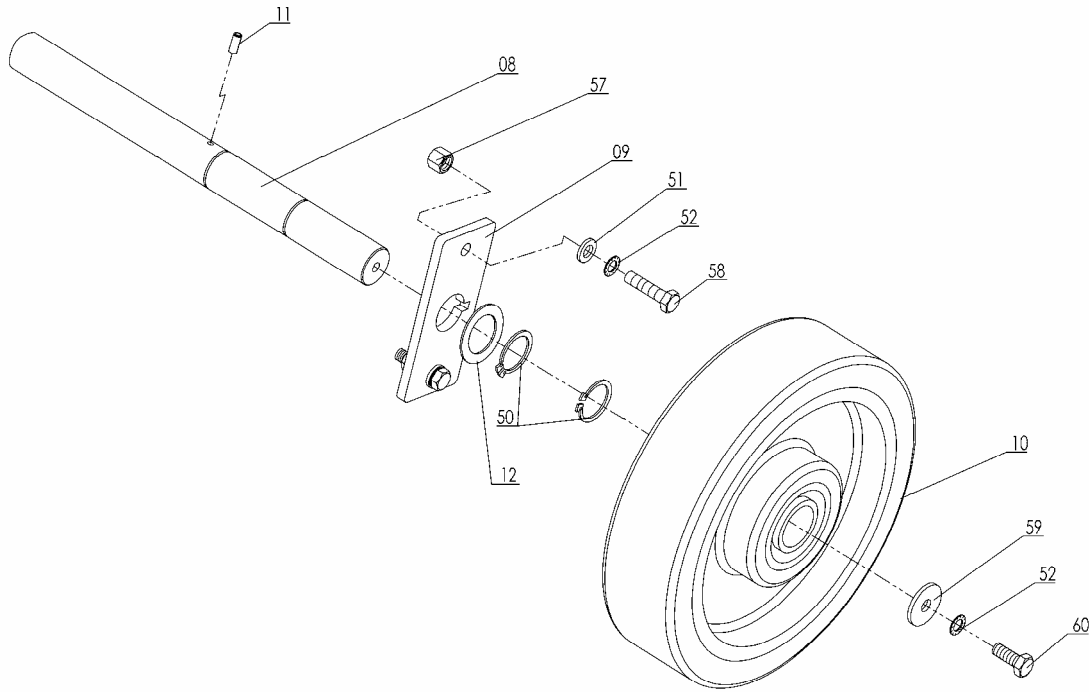

AXLE ASSEMBLY for PROTEUS 26BA		
Item	Part number	Description
8	42317020	AXLE
9	42317030	SUPPORT
10	67010300	WHEEL
11	71404001	SPRING PIN
12		WHEEL SPACER (1.0mm Optional)
12		WHEEL SPACER (1.5mm Optional)
50	70220016	RETAINING RING
51	980042	WASHER
52	980045	LOCK WASHER
57	924026	LOCK NUT
58	964116	SCREW
59	980065	WASHER
60	964107	SCREW

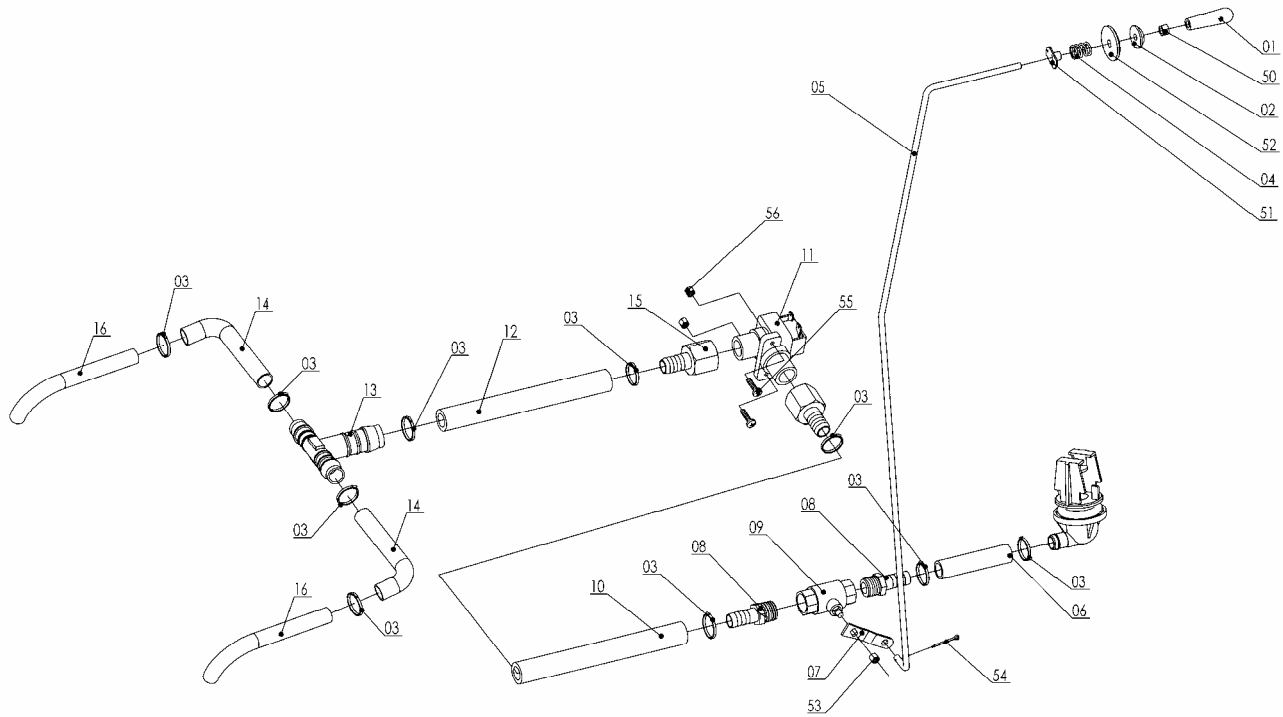

WATER CONTROL ASSEMBLY

Item	Part number	Description	Item	Part number	Description
1	885044	KNOB	13	863305	TEE FITTING
2	980621	SPECIAL WASHER	14	864111	TUBING
3	882051	HOSE CLAMP	15	863306	FITTING
4	888345	SPRING	16	40701170	PIPE
5	42337010	ROD	50	924046	NUT
6	67523060	TUBING	51	924047	NUT
7	865140	LEVER	52	980061	WASHER
8	863308	FITTING	53	71010603	NUT
9	869405	VALVE	54	925609	SPLIT PIN
10	864109	TUBING	55	70910401	SCREW
11	911312	SOLENOID VALVE	56	924029	LOCK NUT
12	864110	TUBING			

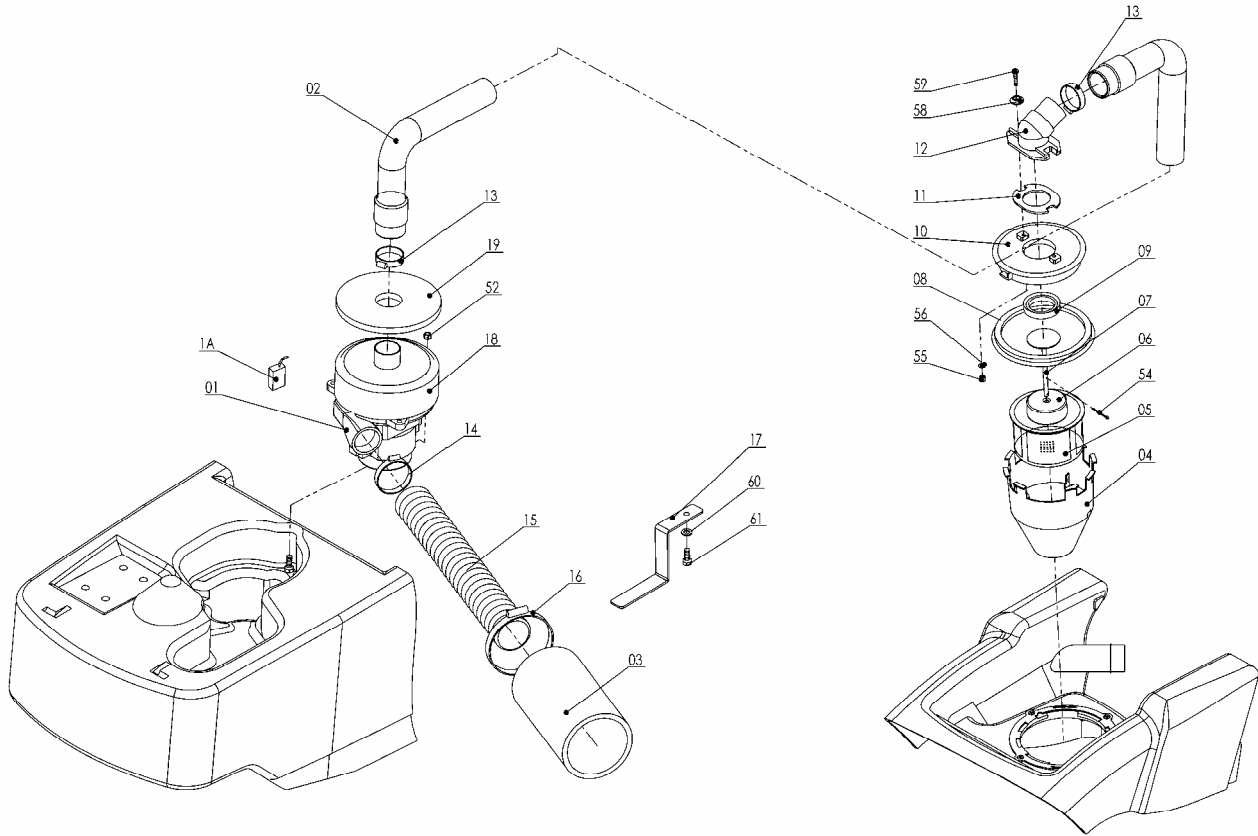

VACUUM ASSEMBLY					
Item	Part number	Description	Item	Part number	Description
1	68120460	VACUUM MOTOR	14	74220059	HOSE CLAMP
1A	880951	CARBON BRUSH	15	67512050	PIPE
2	67512630	VACUUM HOSE	16	882030	HOSE CLAMP
3	67101390	SOUND DEADENING HOSE	17	42341020	BRACE
4	888551	SPLASH GUARD	18	67101090	SOUND DEADENING GASKET
5	883343	FILTER	19	67101080	SOUND DEADENING GASKET
6	883344	FLOAT	52	924050	LOCK NUT
7	887440	LEVER	54	925603	SPLIT PIN
8	883441	GASKET	55	924045	LOCK NUT
9	883442	GASKET	56	71104002	WASHER
10	886841	COVER	58	980621	CUSTOM WASHER
11	883446	GASKET	59	964105	SCREW
12	882442	INLET	60	980039	WASHER
13	S611A	HOSE CLAMP	61	70910803	BOLT

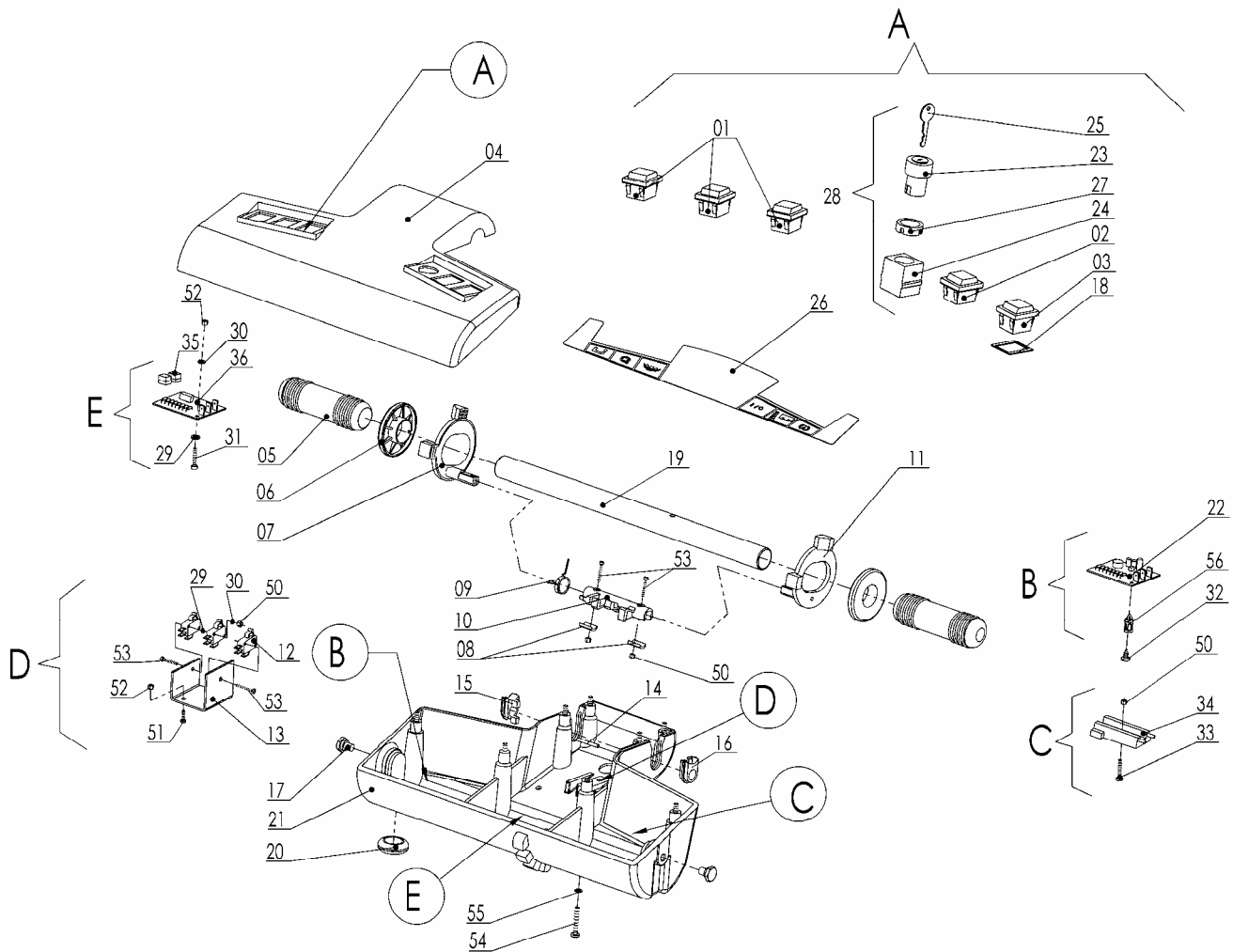

HANDLE ASSEMBLY for PROTEUS 26					
Item	Part number	Description	Item	Part number	Description
1	72102009	ROCKER SWITCH	23	911390	LOCK
2	72300117	SIGNAL CONTROL BATTERY	24	911310	SOCKET
3	72300205	PARKING BRAKE INDICATOR	25	865003	KEY
4	862306	HANDLE BAR	26	865116	LABEL
5	885042	KNOB	27	72199018	BEZEL
6	980623	SPECIAL WASHER	28	911311	SWITCH KIT
7	885141	LEVER	29	980663	WASHER
8	882140	CLIP RETAINING	30	70940305	WASHER
9	888343	SPRING	31	964193	SCREW
10	41328010	SHAFT	32	964192	SCREW
11	885142	LEVER	33	964194	SCREW
12	911170	SNAP ACTION SWITCH	34	72600006	BRAKE RESISTOR
13	888548	BRACKET	35	68420510	RELAY
14	71404005	SPRING PIN	36	67900028	CHOPPER CARD
15	887240	RETAINER RH	50	924043	LOCK NUT
16	887241	RETAINER LH	51	70910407	BOLT
17	42326010	CUSTOM SCREW	52	924031	LOCK NUT
18	883440	GASKET	53	964101	SCREW
19	886040	PIPE	54	964195	SCREW
20	883841	GROMMET	55	980041	LOCK WASHER
21	861311	HANDLE BAR BODY	56	868531	LOCKING CIRCUIT BOARD SUPPORT
22	911417	BATTERY CHECK CARD			

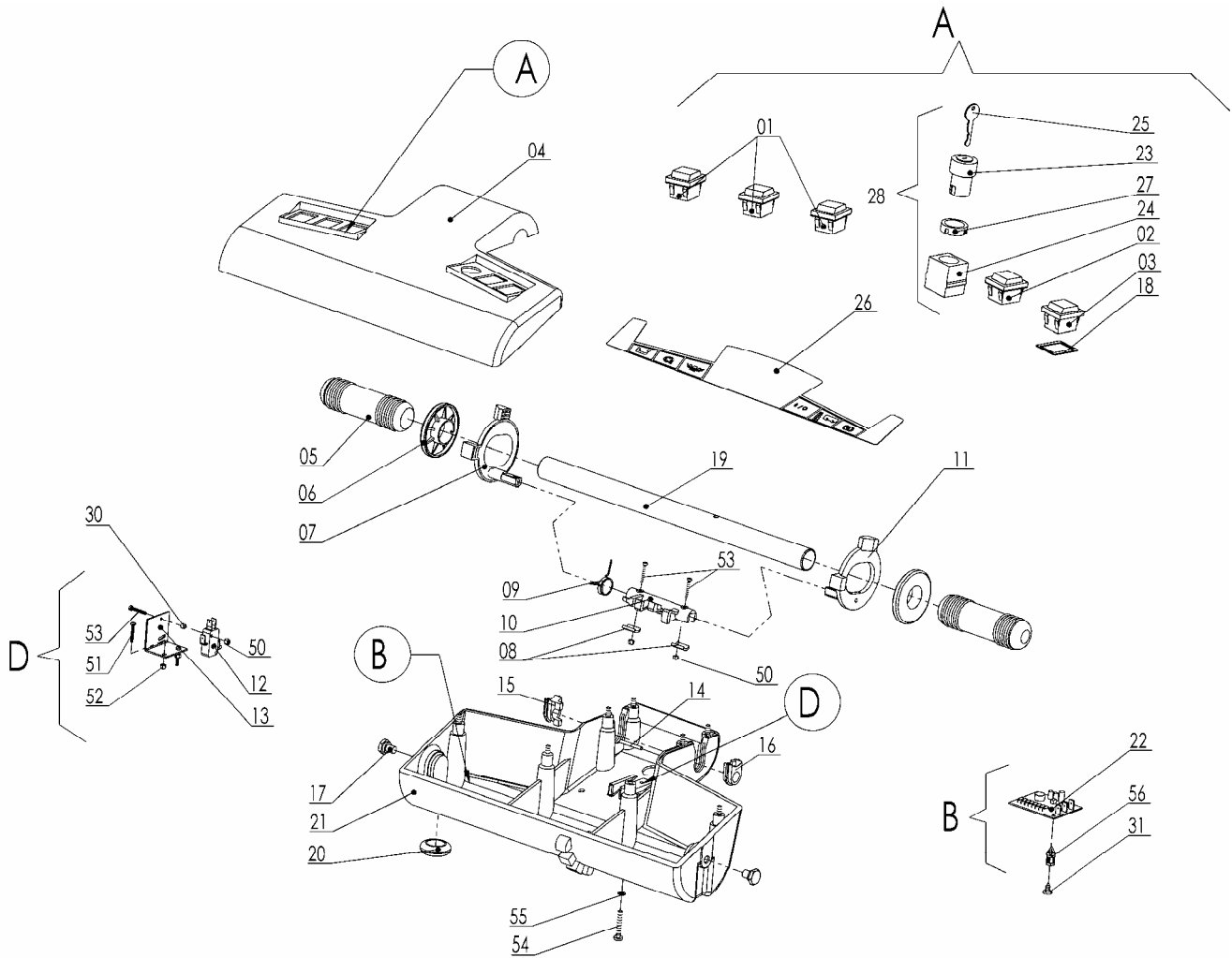

HANDLE ASSEMBLY for PROTEUS 26BA					
Item	Part number	Description	Item	Part number	Description
1	72102009	ROCKER SWITCH	20	883841	GROMMET
2	72300117	SIGNAL CONTROL BATTERY	21	861311	HANDLE BAR BODY
3	72300205	PARKING BRAKE INDICATOR	22	911417	BATTERY CHECK CARD
4	862306	HANDLE BAR	23	911309	LOCK
5	885042	KNOB	24	911310	SOCKET
6	980623	SPECIAL WASHER	25	865003	KEY
7	885141	LEVER	26	865116	LABEL
8	882140	CLIP RETAINING	27	72199018	BEZEL
9	888343	SPRING	28	911311	SWITCH KIT
10	41328010	SHAFT	29	980663	WASHER
11	885142	LEVER	30	881550	BUSHING
12	911170	SNAP ACTION SWITCH	31	964192	SCREW
13	888548	BRACKET	50	924043	LOCK NUT
14	71404005	SPRING PIN	51	70910407	BOLT
15	887240	RETAINER RH	52	924031	LOCK NUT
16	887241	RETAINER LH	53	964101	SCREW
17	42326010	CUSTOM SCREW	54	964123	SCREW
18	883440	GASKET	55	980041	LOCK WASHER
19	886040	PIPE	56	868531	LOCKING CIRCUIT BOARD SUPPORT

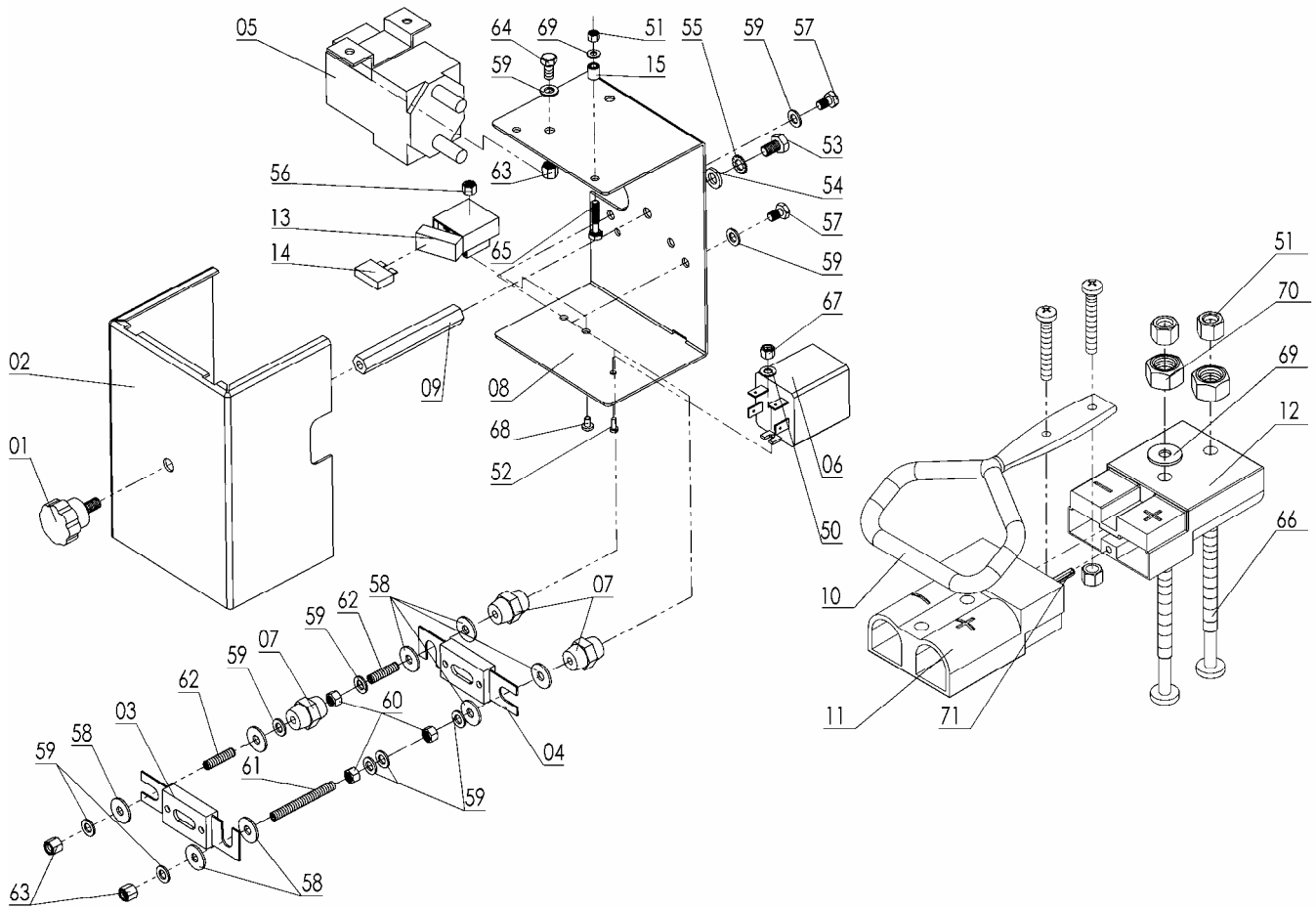

ELECTRICAL ASSEMBLY					
Item	Part number	Description	Item	Part number	Description
1	74006003	KNOB	54	980042	WASHER
2	42351020	COVER	55	980045	LOCK WASHER
3	72408001	FUSE	56	924066	NUT
4	72403502	FUSE	57	964082	SCREW
5	68420110	CONTACTOR	58	980659	WASHER
6	887550	RELAY	59	980066	WASHER
7	884750	INSULATOR	60	924060	NUT
8	861314	COVER	61	964184	SCREW
9	42351030	STUD BOLT	62	70960502	SCREW
10	72700015	CONNECTOR HANDLE	63	924045	LOCK NUT
11	72700011	CONNECTOR MALE	64	964133	SCREW
12	72700012	CONNECTOR FEMALE	65	964177	SCREW
13	864004	FUSE HOLDER	66	70940301	SCREW
14	72400301	FUSE	67	920646	NUT
15	868211	SPACER	68	964185	SCREW
50	980662	WASHER	69	980663	WASHER
51	924031	LOCK NUT	70	924063	NUT
52	964198	SCREW	71	925613	PIN
53	964088	SCREW			

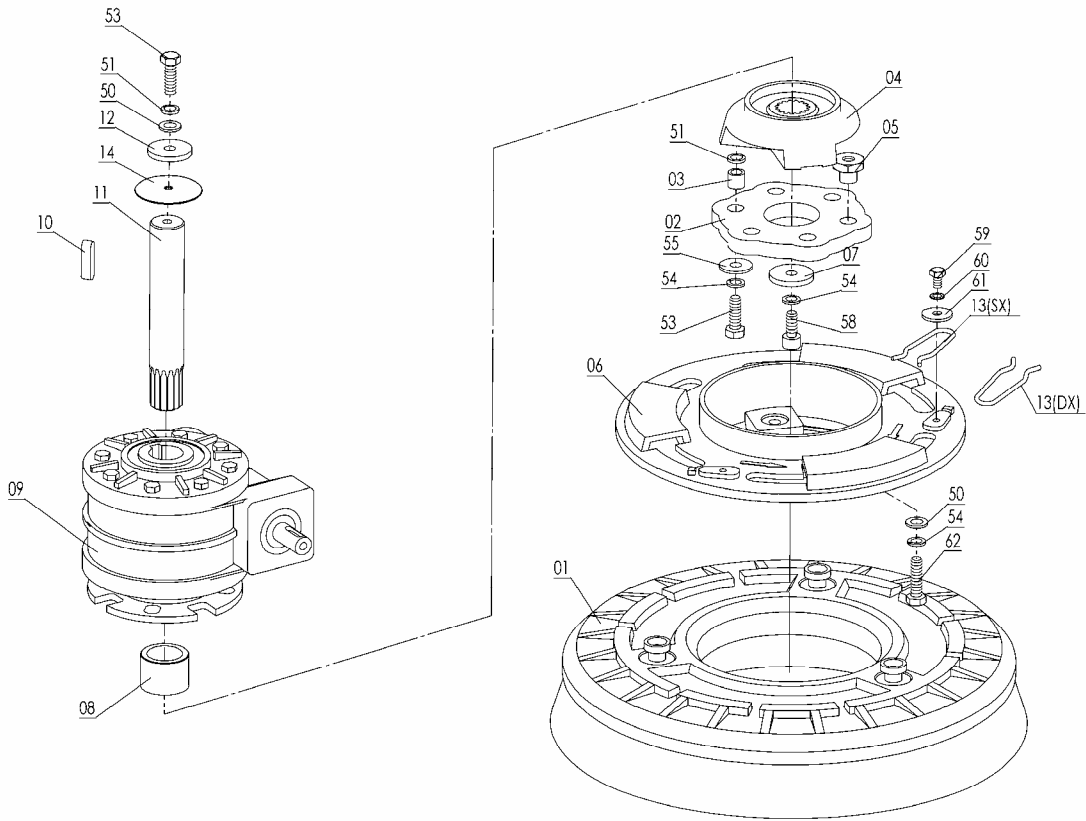

BRUSH ASSEMBLY					
Item	Part number	Description	Item	Part number	Description
1	885970	PAD DRIVER	11	40701160	SHAFT
(1)	880970	BRUSH (Optional)	12	40301160	CAP
2	40301070	FLEXIBLE COUPLING PROTEUS 26	13	69230010	SPRING
2	862415	FLEXIBLE COUPLING PROTEUS 26BA	50	980053	WASHER
3	69009040	SPACER	51	71108009	WAVE WASHER
4	41201040	FLANGE PROTEUS 26	53	964090	SCREW
(4)	863309	FLANGE PROTEUS 26BA	54	980069	LOCK WASHER
5	69109040	BUSHING	55	980044	WASHER
6	41201050	BRUSH PLATE	58	70930801	SCREW
7	40205080	CUSTOM WASHER	59	70910602	SCREW
8	69006060	SPACER	60	980045	LOCK WASHER
9	68600010	REDUCTION GEAR ASSEMBLY	61	980065	WASHER
10	70408071	KEY	62	964170	SCREW



PACIFIC

WIRING DIAGRAM for PROTEUS 26		
Item	Part Number	Description
1-1	911366	WIRE BLACK
1-2	911367	WIRE BLACK
1-3	911368	WIRE BLACK
1-4	911369	WIRE BLACK
1-5	911370	WIRE BLACK
1-6	911371	WIRE BLACK
1-7	911372	WIRE BLACK
2-1	911373	WIRE RED
2-2	911374	WIRE RED
2-3	911375	WIRE RED
2-4	911376	WIRE RED
3-1	911377	WIRE BLUE
3-2	911378	WIRE BLUE
3-3	911379	WIRE BLUE
3-4	911380	WIRE BLUE
3-5	911381	WIRE BLUE
4-1	911382	WIRE BROWN
4-2	911383	WIRE BROWN
5	911384	2 WIRES BLUE-BROWN WITH BLACK JACKET
6	911385	WIRE RED
7-1	911386	2 WIRES BLUE-BROWN WITH WHITE JACKET
7-2	911387	2 WIRES BLUE-BROWN WITH WHITE JACKET
8	911388	WIRE YELLOW
9	911323	WIRE GREEN
10-11	911390	WIRE BLACK-RED
12	911392	WIRE BLACK
13	911393	WIRE RED
14	911314	CONNECTOR, BATTERY TERMINALS AND BLACK-RED WIRES
15	911416	CONNECTOR WITH BLACK-RED WIRES
16	911326	CABLE BRIDGE WITH BATTERY TERMINALS
17	68000892	CABLE DISPLAY BATTERY SIGNAL
18-1	911394	WIRE BLUE
18-2	911395	WIRE BLUE
A	72102009	GREEN SWITCH SOLENOID VALVE
B	72102009	GREEN SWITCH VACUUM MOTOR
C	72102009	GREEN SWITCH BRUSH MOTOR
D	911311	CONTACT KEY
E	72300117	SIGNAL CONTROL BATTERIES
F1	72400301	FUSE 3A
F2	72403502	FUSE 35A VACUUM MOTOR
F3	72408001	FUSE 80A BRUSH MOTOR
F4	72403001	FUSE 30A SPEED CONTROL CARD
G	911396	CONNECTOR
H	67900028	SPEED CONTROL CARD 24V
I	911397	TRIMMER ADJUSTMENT LOW SPEED
J	911398	CONNECTOR
K1	72500008	DIODE 1N4007
K2	911399	DIODE 1N5408
L	911400	TRIMMER ADJUSTMENT ACCELERATION
M1	865206	BRUSH MOTOR
M2	68120460	VACUUM MOTOR
M3	865205	TRAVERSE MOTOR
M1-1	911170	SNAP ACTION SWITCH FIRST SPEED
M1-2	911170	SNAP ACTION SWITCH SECOND SPEED
M1-3	911170	SNAP ACTION SWITCH BACKWARD SPEED
N	68420510	RELAY 24V 20A BACKWARD
O	68420510	RELAY 24V 20A FORWARD
P	887550	RELAY 24V 30A VACUUM MOTOR
Q	68420120	REMOTE SWITCH 24V 30A BRUSH MOTOR
R	72600006	BRAKING RESISTANCES 50W
S	72903002	INSULATOR M5x25FF
T	911312	SOLENOID VALVE
U	72300205	SIGNAL LAMP PARKING
V	911308	BATTERY CHECK CARD
C1	911401	CAPACITOR 470n 250v
D1	72500008	DIODE 1N4007
R1	911402	RESISTOR 220Ω
Z	72105009	SNAP ACTION SWITCH BRAKE

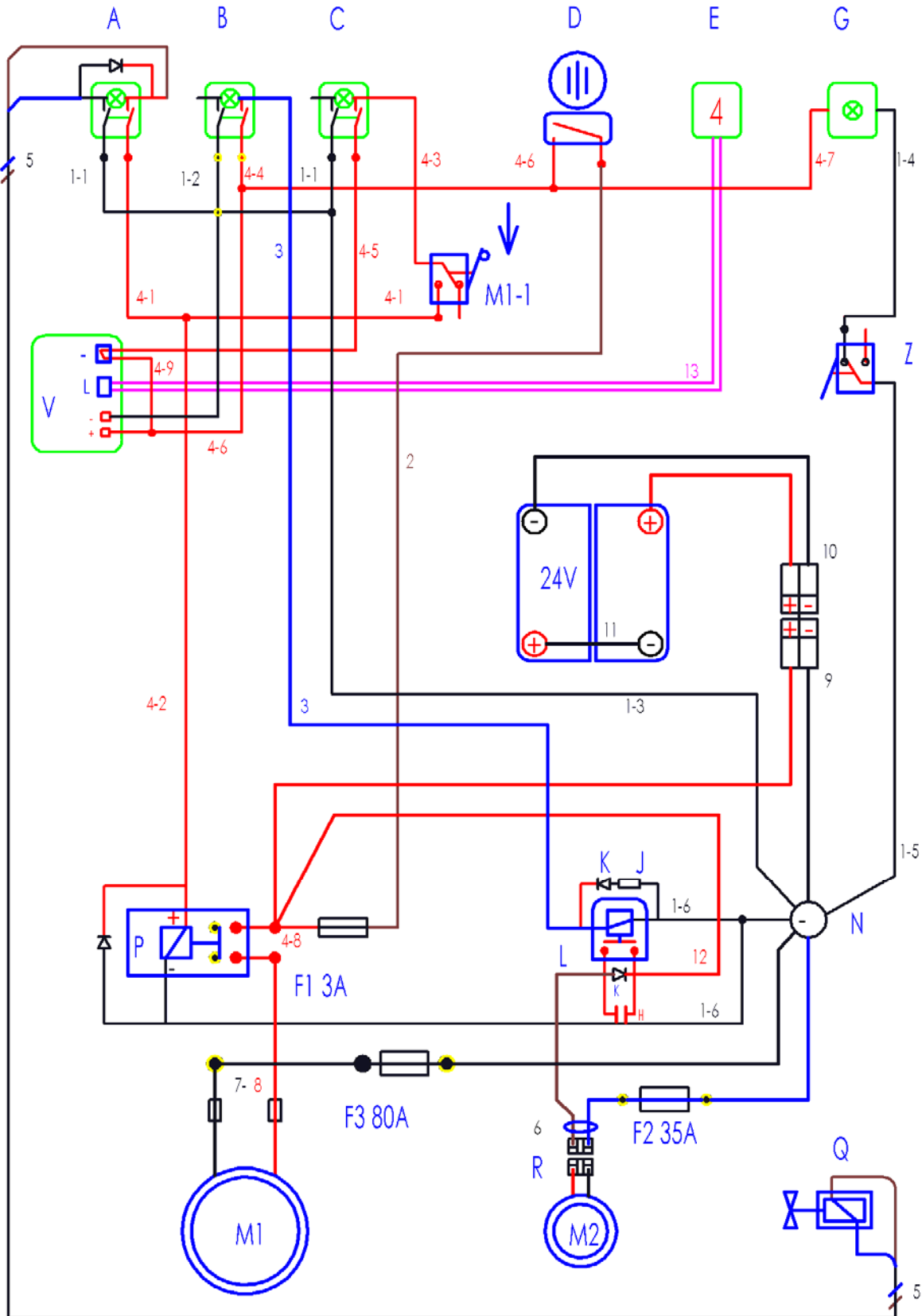



PROTEUS 26BA WIRING DIAGRAM

Item	Part number	Description
1-1	911368	WIRE BLACK
1-2	911404	WIRE BLACK
1-3	911366	WIRE BLACK
1-4	911405	WIRE BLACK
1-5	911371	WIRE BLACK
1-6	911369	WIRE BLACK
2	911406	WIRE BROWN
3	911377	WIRE BLUE
4-1	911407	WIRE RED
4-2	911408	WIRE RED
4-3	911409	WIRE RED
4-4	911410	WIRE RED
4-5	911411	WIRE RED
4-6	911412	WIRE RED
4-7	911413	WIRE RED
4-8	911414	WIRE RED
4-9	911373	WIRE RED
5	911384	2 WIRES BLUE-BROWN WITH BLACK JACKET
6	911386	2 WIRES BLUE-BROWN WITH WHITE JACKET
7-8	68023010	WIRE RED-BLACK
9	911314	CONNECTOR WITH BLACK-RED WIRES
10	68024001	CONNECTOR, BATTERY TERMINALS AND BLACK-RED WIRES
11	68000154	CABLE BRIDGE WITH BATTERY TERMINALS
12	911415	WIRE RED
13	68000892	CABLE DISPLAY BATTERY SIGNAL
A	72102009	GREEN SWITCH SOLENOID VALVE
B	72102009	GREEN SWITCH VACUUM MOTOR
C	72102009	GREEN SWITCH BRUSH MOTOR
D	911311	CONTACT KEY
E	72300117	SIGNAL CONTROL BATTERIES
F1	72400301	FUSE 3A
F2	72403502	FUSE 35A VACUUM MOTOR
F3	72408001□	FUSE 80A BRUSH MOTOR
G	72300205	SIGNAL LAMP PARKING
H	911401	CAPACITOR 470n 250v
J	911402	RESISTOR 220Ω
K	72500008	DIODE 1N4007
L	887550	RELAY 24V 30A VACUUM MOTOR
M1	865206	BRUSH MOTOR
M2	68120460	VACUUM MOTOR
M1-1	911170	SNAP ACTION FIRST SPEED
N	72903002	INSULATOR M5×25FF
P	68420120	REMOTE SWITCH 24V 30A BRUSH MOTOR
Q	911312	SOLENOID VALVE
R	72700007	DOUBLE CONNECTOR 30A VACUUM MOTOR
V	911308	BATTERY CHECK CARD
Z	72105009	SNAP ACTION SWITCH BRAKE



WARRANTY POLICY PACIFIC LIMITED WARRANTY

The **Pacific** Proteus 26 and 26BA have been manufactured, tested and inspected in accordance with specific engineering requirements. This machine is **WARRANTED** to be free from defects in workmanship and materials for periods as follows from the date of purchase.

Ten (10) Years Parts, One (1) Year Labor – Polyethylene Components
Five (5) Years Parts, One (1) Year Labor – Main Frame
Two (2) Years Parts, One (1) Year Labor – Brush Drive Motors
One (1) Year Parts & Labor – All other components unless excluded below

Travel time for warranty repair is authorized for a period of ninety (90) days following the date of sale to the end user, with a maximum of three (3) hours per claim.

This warranty extends to the original user/purchaser and only when used, operated and maintained in accordance with **Pacific** Operating and Maintenance instructions.

This warranty does not apply to certain wear parts and accessories of the machine such as electrical cords, carbon motor brushes, floor brushes, belts, hoses, tools, squeegee blades, etc., nor does it apply to damage or failure caused by improper use, abuse or neglect. Warranty credit of return parts including motors, pumps, etc., is subject to incoming inspection of those items.

To secure repair under this warranty, the following procedure should be taken:

1. After the expiration of the ninety (90) day travel time warranty period, the customer is responsible for warranty travel payment for the inoperative machine or warranted parts must be delivered to the authorized dealer with shipping and delivery charges prepaid. If unable to locate the Dealer, you may contact **Pacific** at the address listed herein for the location of the nearest **Pacific** repair center or agent or for other instructions pertaining to your warranty difficulty.
2. Upon compliance with the above warranty procedure, all warranted repairs will be completed at no additional charge or cost to the user.
3. Only **Pacific** or its authorized dealers and agents may make no charge warranty repairs on this product. All others do so at their own risk.

This warranty limits **Pacific** liability to the repair of the product and/or warranted parts replacement and does not include incidental or consequential damages arising from the use of a **Pacific** machine whether defective or not.

BATTERY WARRANTY

In addition to the terms above, any original equipment **Pacific** battery which becomes unserviceable under normal use within a period of ninety (90) days from the date of sale to the original user will be repaired or replaced with one of equal specification at our option, F.O.B. any authorized **Pacific** sales or service branch, with no charge to user, except transportation costs. After the expiration of the above ninety (90) day period, any battery which fails under normal use will be adjusted to the original user with a new battery of equal specification on a twelve (12) month pro rata basis from the date of purchase. Adjustments will be determined using the then current list price, plus transportation costs. Warranty is rendered null and void if battery is not kept filled to the proper level with **DISTILLED WATER**.

This warranty is in lieu of all other expressed or implied warranties and is extended to the original purchaser/user.