



Electronic Service Manuals

This electronic document is provided as a service to our customers. We do not create the contents of the information contained in this document. Should you have detailed questions pertaining to the information contained in this document, you may contact Michco, or the manufacturer which provided the original information in this electronic deliverable. Michco's only part in this electronic deliverable was the electronic assembly process. By providing this manual on line we are not guaranteeing parts availability.

You may contact Michco through the following methods:

Phone (517) 484-9312 or (800) 331-3339

2011 N. High St. -- Lansing, Michigan -- 48906

Fax: (517) 484-9836

Email: CustServe@Michco.com

Web site: www.Michco.Com

Parts Web site: www.FloorMachineParts.Com

Order Parts on Line at:

www.FloorMachineParts.Com

Directly to Parts & Service:

By Email: **Shop@Michco.com**

By Fax: (517) 702-2041

By Voice: Use numbers above.

Serving the Cleaning Industry Since 1922

Notice: All copyrighted material remains property of original owners, all trademarks are property of respective owners. Manuals are subject to Manufacturer's reproduction limitations. Originals or reproductions were provided by manufacturers through a request. We make no warranty as to the correctness of information provided in this document and you assume all risk. By placing these manuals on line we are not declaring our corporation to be an manufacturer authorized dealer or provider, please check our web site for authorized manufacturers we represent.



NOBLES POWER BRUSH

PART NO. 20650
STARTING SERIAL NO. 373116

This Nobles Power Brush has been tested and preadjusted at the factory. Additional adjustments may be made as follows:

Spray Pattern

If a streak is left on carpet, spray nozzles may be adjusted by loosening clamps (Item No. 7) and rotating PVC Tube (Item No. 5) slightly until all spray patterns overlap approximately 1/4".

If nozzles clog they can be cleaned by removing both end caps (Item No. 16) and flushing pipe out with clean water. If debris becomes lodged in spray nozzles they may be removed and blow cleaned or washed.

Brush Pressure

When brush bristles become worn to approximately 5/16" both bearing blocks can be rotated 180° so numeral "one" is toward the frame surface and away from the carpet surface. This doubles the life of the brush.

When replacing old brush be sure bearing blocks show numeral "one" toward carpet surface.

NEW

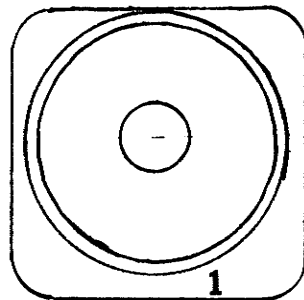

USED

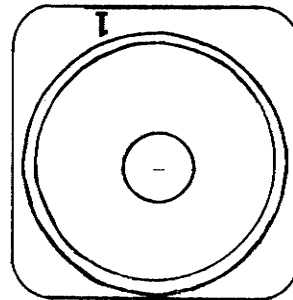

CARPET SURFACE

The two black rubber blocks that hold the brush bearings are originally positioned with the numeral "one" toward the cleaning surface. When brush becomes worn, both blocks should be rotated as shown. This will lower brush. When replacing brush (K20844) make sure both blocks are in their original position.

NOBLES POWER BRUSH PART NO. 20650

Item No.	Part No.	Description	Item No.	Part No.	Description
1	K20860	Handle Grip	15	K20873	Bushing
2	K21885	Screw # 10-24 x 1-3/4	16	K20874	Handle Tube
4	K20863	Handle	17	K20875	Bushing
5	K20864	Handle	18	K20876	Lead
6	K19420	Lockwasher	19	K20877	Wire
7	K20865	Cable Ass'y	20	K20878	Screw
8	K23119	Switch Box Asm.	21	K20879	Switch
9	K20867	Bushing	22	K20880	Pin
10	K19280	Screw	23	A20816	Decal
11	K20869	Receptacle	24	K23120	Rectifier
12	K21886	Axle	25	K20882	Lever, Kick
13	K19476	E-Ring	26	K20883	Dowel Pin
14	K20872	Screw 6-32 x 1/2	27	K20884	Cam Washer
			28	K19468	Nut
			29	K20885	Bolt
			30	K20886	Clamp
			31	K20887	Roller
			32	K20888	Solution Hose
			33	K19109	Spacer
			34	K20890	Tube
			35	K21887	Wirenut
			36	K20892	Clamp Hose
			37	K20893	Hose Barb
			38	K15296	Quick Coupling
			39	K20894	Bracket
			40	K20895	Screw
			41	K20896	Slip Adapter
			42	K20897	Hose Barb
			43	K20898	Plug F.M. (Replacement)
			44	K20899	Plug, Male (Replacement)
			45	B22888	28 ft. Cord
			46	B20901	50 ft. Cord to Wall Outlet (Replacement)
			47	K19420	Washer
			48	K21888	Washer
			49	K21889	Wirenut
			50	K21900	Lock Ring
			51	K21901	Clamp
			52	K20895	Screw
			53	K22342	Circuit Breaker
			54	K22542	Connector
			55	K22543	Insulator Paper
			56	K20872	Screw No. 6-32 x 1/2
			57	K19275	No. 6 Washer, Lock
			58	K23121	Lead Asm. White
			59	K22593	Lead Asm. Black
			60	K22592	Lead Asm. Black
			61	K22674	Bushing
			62	K23264	Terminal

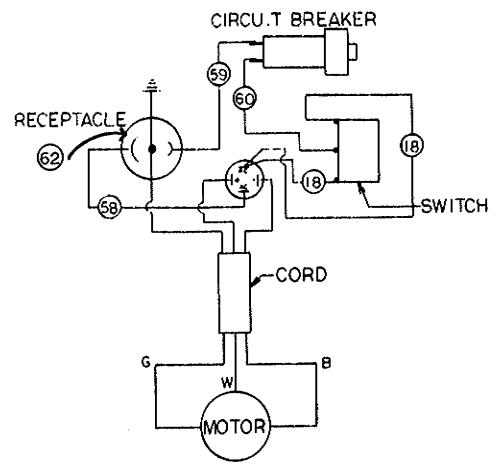
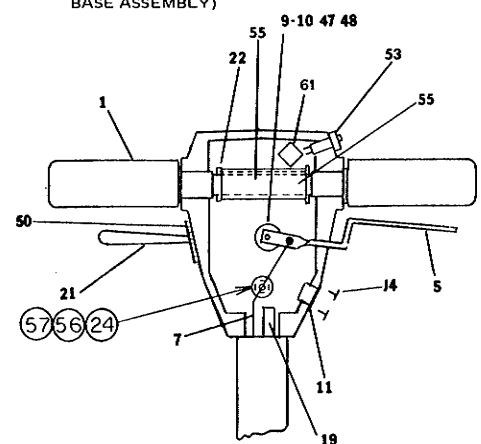
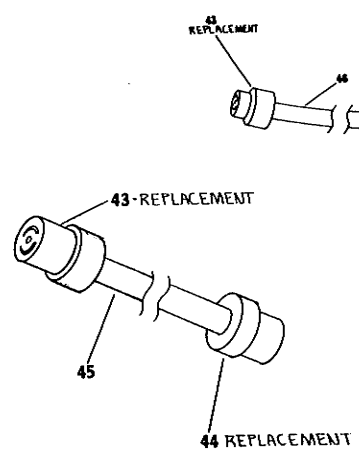
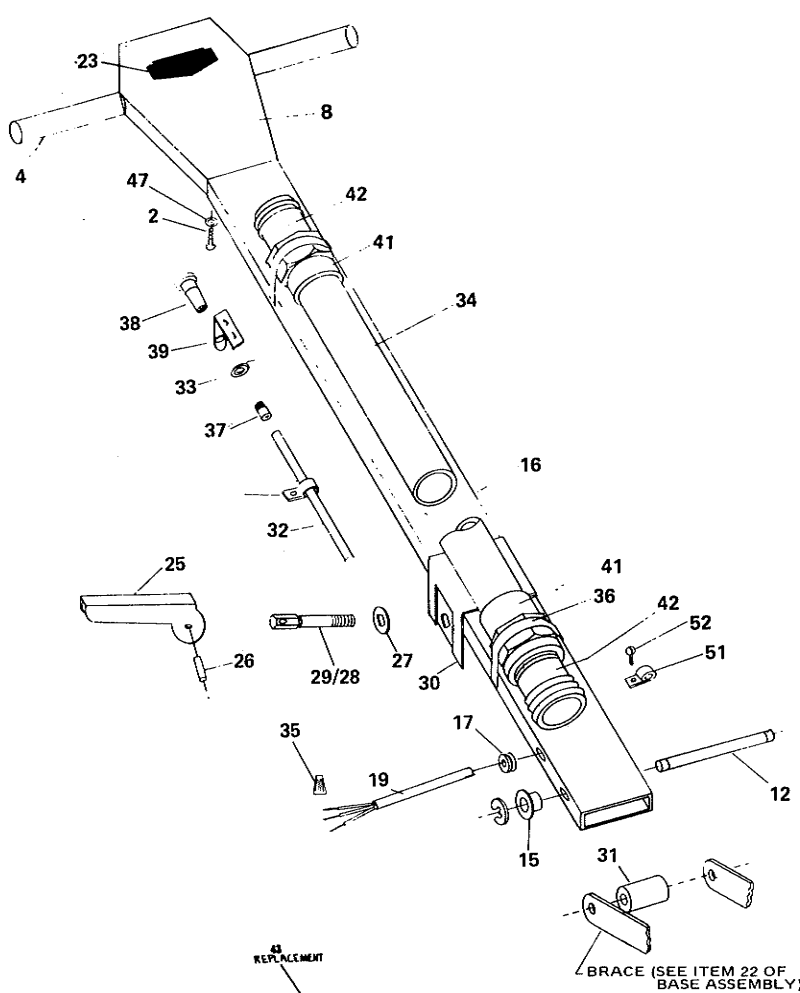

**NOBLES POWER BRUSH
PART NO. 20650**

Item No.	Part No.	Description
5	K20822	Spray Tube
6	K20823	Spray Nozzle
7	K20824	Clamp
16	K20833	End Cap
17	K20834	Hose Barb
23	K20840	Valve Ass'y
24	K20841	Bracket
38	K20852	Hose
52	K19276	Inter. Washer 1/4
53	K19280	Screw # 10-24x1/2
54	K19286	Screw 1/4-20x1/2 Hex
57	K19109	Spacer
58	K20893	1/4 Pipe Connector
60	K19277	Washer # 10

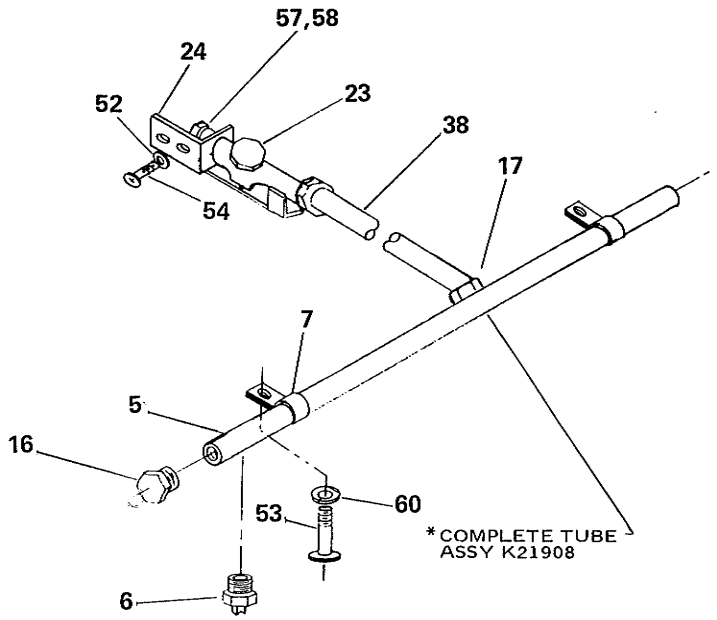

Item No.	Part No.	Description
1	K20818	Frame Main
2	K20819	Brush Plate
3	K20820	Gasket
4	K22546	Motor Mount
8	K21327	Belt
10	K21902	Bar, Weight
11	K20828	Cover
12	K20829	Wheel
13	K20830	Axle
14	K20831	Bracket Handle
15	K23123	Motor
18	K21903	Screw
19	K20836	Washer
20	K23615	Brush Shield
21	K23614	Motor Cover
22	K20839	Brace
25	B6742	Decal
26	K23124	Flange Bearing
27	K23125	Door Tight
28	K20843	Screw 8-32 x 3/8
29	K20844	Brush Core

Item No.	Part No.	Description
30	K20845	Screw 8-32 x 5/8
31	K19025	Hose
32	K19264	Hose Clamp
33	K19019	Screw
34	K20849	Bearing Block
35	K20850	Bearing
36	K20851	Brush Shaft
37	A20817	Name Plate
39	K19513	E-Ring
40	K20853	Spring Washer
41	K20854	Shoe

Item No.	Part No.	Description
42	K19767	Washer
43	K20856	Brace
47	K21904	Screw 1/4-20x2-1/4
51	K21906	#8-32 Inter. Washer
56	K21328	Pulley, Flanged
59	K19259	Clamp-Stick on
61	K19383	Nut, Keps # 10-24

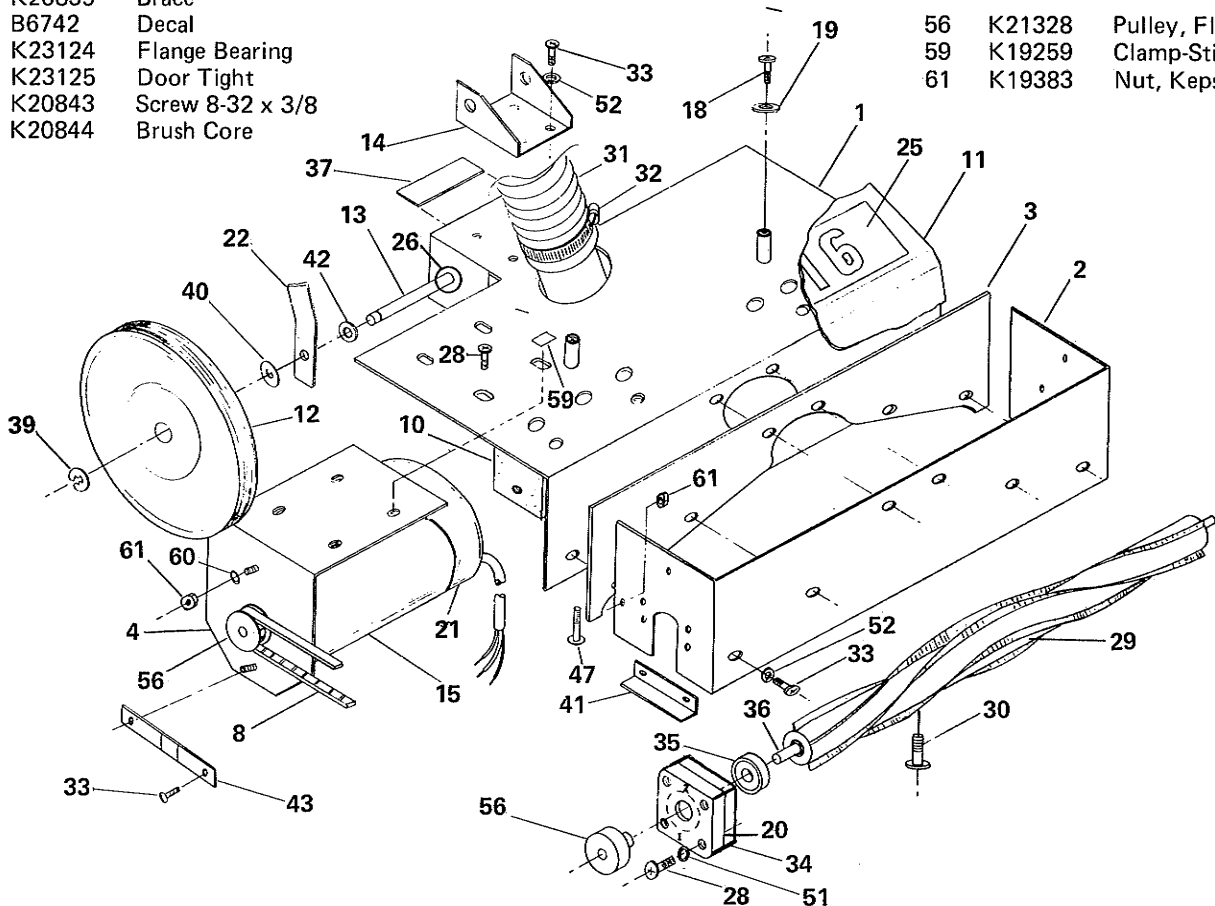

NOBLES POWER BRUSH GENERAL MAINTENANCE

1. Clean lint and debris from brush and brush shaft bearing holders. This should be done once per week if machine is used daily. A buildup of hair, lint or carpeting between the end of the Brush and the Bearing Holder can wear out the Bearing Water-Tite seal and cause premature bearing failure due to corrosion of the bearing.
2. Flush spray system with hot water after every use to prevent detergent buildup on spray tips and spray tube.
3. Clean squeegee bar periodically to prevent debris buildup. A visual inspection before use is recommended once every two weeks. Flush this area out with hot water.

