



## Electronic Service Manuals

This electronic document is provided as a service to our customers. We do not create the contents of the information contained in this document. Should you have detailed questions pertaining to the information contained in this document, you may contact Michco, or the manufacturer which provided the original information in this electronic deliverable. Michco's only part in this electronic deliverable was the electronic assembly process. By providing this manual on line we are not guaranteeing parts availability.

You may contact Michco through the following methods:

Phone (517) 484-9312 or (800) 331-3339

2011 N. High St. -- Lansing, Michigan -- 48906

Fax: (517) 484-9836

Email: [CustServe@Michco.com](mailto:CustServe@Michco.com)

Web site: [www.Michco.Com](http://www.Michco.Com)

Parts Web site: [www.FloorMachineParts.Com](http://www.FloorMachineParts.Com)

Order Parts on Line at:

**[www.FloorMachineParts.Com](http://www.FloorMachineParts.Com)**

Directly to Parts & Service:

By Email: **[Shop@Michco.com](mailto:Shop@Michco.com)**

By Fax: (517) 702-2041

By Voice: Use numbers above.

**Serving the Cleaning Industry Since 1922**

Notice: All copyrighted material remains property of original owners, all trademarks are property of respective owners. Manuals are subject to Manufacturer's reproduction limitations. Originals or reproductions were provided by manufacturers through a request. We make no warranty as to the correctness of information provided in this document and you assume all risk. By placing these manuals on line we are not declaring our corporation to be an manufacturer authorized dealer or provider, please check our web site for authorized manufacturers we represent.



# Frontier<sup>TM</sup>

Self-Contained Carpet Extractor

Model No.:  
608549

Operator and Parts Manual

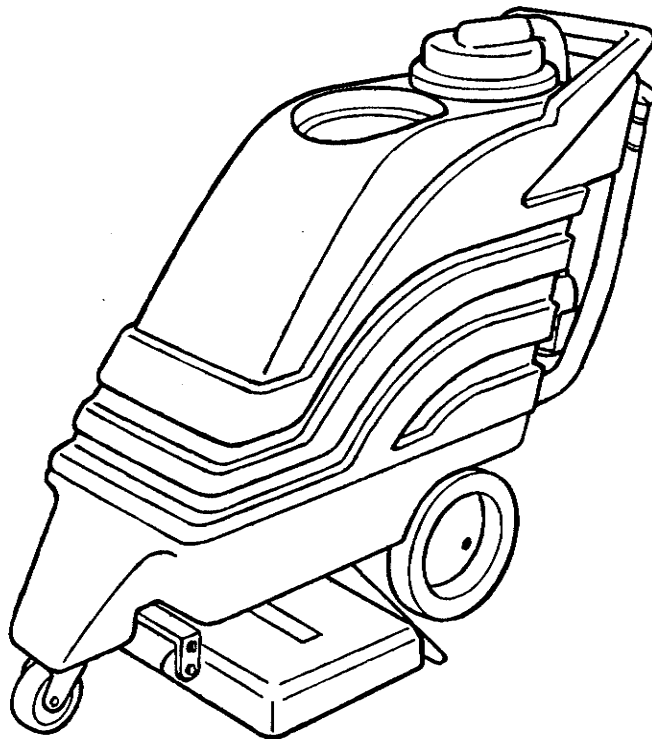

NOBLES  
12875 RANSOM STREET  
HOLLAND MI 49424 U.S.A.

CUSTOMER SERVICE: 1-800-365-6625  
FAX: 1-800-678-4240

608550  
Rev. 00 (09-99)

# OPERATION

---

This manual is furnished with each new machine. It provides necessary operation and maintenance instructions and an illustrated parts list.

**Read this manual completely to understand the machine before operating or servicing it.**

When ordering replacement parts use the Parts Lists in this manual. Before ordering parts or supplies, be sure to have your machine model number and serial number handy. Parts and supplies may be ordered by phone or mail from any Authorized Service Center or Distributor.

This machine will provide excellent service. However, the best results will be obtained at minimum costs if:

- The machine is operated with reasonable care.
- The machine is maintained regularly - per the machine maintenance instructions provided.
- The machine is maintained with manufacturer supplied or equivalent parts.

---

## MACHINE DATA

---

Please fill out at time of installation for future reference.

Model No.- \_\_\_\_\_

Install. Date - \_\_\_\_\_

Serial No.- \_\_\_\_\_

© 1999 Tennant Company Printed in U.S.A

Nobles is a registered United States trademark of Tennant Company. Frontier is a United States trademark of Tennant Company.

Specifications and parts are subject to change without notice.

---

## TABLE OF CONTENTS

---

<b>SAFETY PRECAUTIONS</b> .....	<b>3</b>	<b>STORING MACHINE</b> .....	<b>8</b>
<b>MACHINE COMPONENTS</b> .....	<b>4</b>	<b>RECOMMENDED STOCK ITEMS</b> .....	<b>8</b>
<b>MACHINE SETUP</b> .....	<b>4</b>	<b>TROUBLE SHOOTING</b> .....	<b>8</b>
<b>MACHINE OPERATION</b> .....	<b>5</b>	<b>SPECIFICATIONS</b> .....	<b>9</b>
<b>ADJUSTING BRUSH HEIGHT</b> .....	<b>6</b>	<b>PARTS LIST</b> .....	<b>10</b>
<b>DRAINING TANKS</b> .....	<b>6</b>	<b>ELECTRICAL DIAGRAM</b> .....	<b>21</b>
<b>MACHINE MAINTENANCE</b> .....	<b>7</b>	<b>OPTIONS</b> .....	<b>22</b>

## SAFETY PRECAUTIONS

This machine is intended for commercial use. It is suited to clean carpet and upholstery in an indoor environment and is not constructed for any other use. Use only recommended cleaning solutions and accessory tools.

All operators must read, understand and exercise the following important Safety Precautions.

The following safety alert symbols are used throughout this manual as indicated in their description.

**⚠ WARNING: To warn of hazards or unsafe practices which could result in severe personal injury or death.**

**FOR SAFETY: To identify actions which must be followed for safe operation of equipment.**

The following information signals potentially dangerous conditions to the operator or equipment:

### FOR SAFETY:

1. **Do not operate machine:**
  - Unless trained and authorized.
  - Unless operator manual is read and understood.
  - In flammable or explosive areas unless designed for use in those areas.
  - Unless cord is properly grounded.
  - With damaged cord or plug.
  - If not in proper operating condition.
  - In outdoor areas.
  - In standing water.
2. **Before operating machine:**
  - Make sure all safety devices are in place and operate properly.
3. **When using machine:**
  - Do not run machine over cord.
  - Do not pull machine by plug or cord.
  - Do not pull cord around sharp edges or corners.
  - Do not unplug by pulling on cord.
  - Do not stretch cord.
  - Do not handle plug with wet hands.
  - Keep cord away from heated surfaces.
  - Report machine damage or faulty operation immediately.
4. **Before leaving or servicing machine:**
  - Turn off machine.
  - Unplug cord from wall outlet.

### 5. When servicing machine:

- Unplug cord from wall outlet.
- Avoid moving parts. Do not wear loose jackets, shirts, or sleeves.
- Use manufacturer supplied or approved replacement parts.

**⚠ WARNING: Hazardous Voltage. Shock or electrocution can result. Always unplug machine before servicing.**

**⚠ WARNING: Flammable materials can cause an explosion or fire. Do not use flammable materials in tank(s).**

**⚠ WARNING: Flammable materials or reactive metals can cause an explosion or fire. Do not pick up.**

## GROUNDING INSTRUCTIONS

Machine must be grounded. If it should malfunction or breakdown, grounding provides a path of least resistance for electrical current to reduce the risk of electrical shock. This machine is equipped with a cord having an equipment-grounding conductor and grounding plug. The plug must be plugged into an appropriate outlet that is properly installed in accordance with all local codes and ordinances. Do not remove ground pin; if missing, replace plug before use.

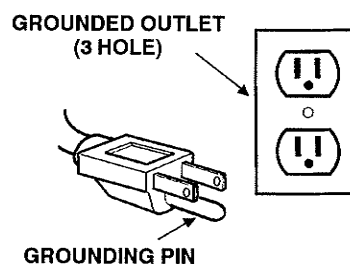

## MACHINE COMPONENTS

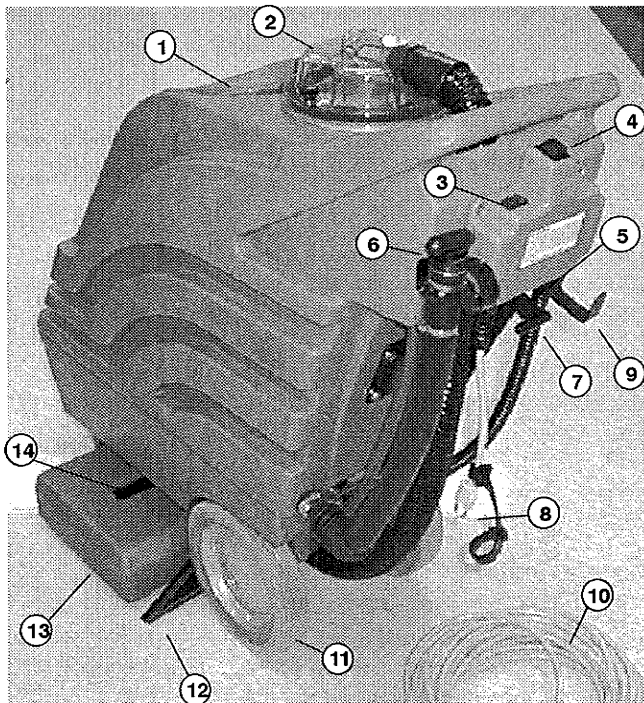

1. Solution Tank Lid
2. Recovery Tank Dome
3. Main Power Switch
4. Brush/Spray Button
5. Circuit Breakers (under switchbox)
6. Recovery Tank Drain Hose
7. Brush/Vacuum Head Lift Lever
8. Power Cord Pigtail
9. Power Cord Storing Hook
10. Detachable 23 m (75 ft) Power Cord
11. 254 mm (10 in) Stair Climbing Wheels
12. Vacuum Head
13. Brush Housing
14. Spray Bar

## MACHINE SETUP

1. Carefully check carton for signs of damage. Report damages at once to carrier. The machine is shipped fully assembled and is ready for operation.
2. Remove solution tank lid and fill tank with 38 liters (10 gallons) of hot water, 60°C (140°F) maximum (Figure 1).

**⚠ WARNING: Flammable materials can cause an explosion or fire. Do not use flammable materials in tank(s).**



FIG. 1

**NOTE:** When using a bucket to fill tank, make sure it is clean. Always use separate buckets when filling and emptying machine.

3. Add a recommended cleaning solution. Follow bottle's mixing instructions.

**NOTE:** If desired, hot water alone achieves excellent cleaning results.

**ATTENTION:** If using powdered cleaning chemicals, mix prior to adding.

4. Replace lid securely after filling.
5. Connect the 23 m (75 ft) detachable power cord to machine, use cord restraint strap provided, then plug cord into a grounded wall outlet (Figure 2).

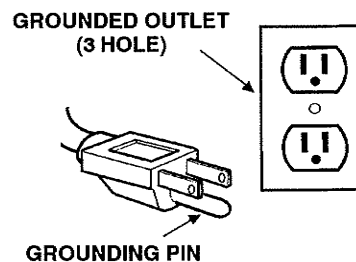

FIG. 2

**FOR SAFETY: Do not operate machine unless cord is properly grounded.**

**MACHINE OPERATION**

**FOR SAFETY: Do not operate unless operator manual is read and understood.**

**NOTE:** Vacuum area prior to operating machine.

1. Turn on main power switch.
2. Lower brush/vacuum head lift lever (Figure 3).

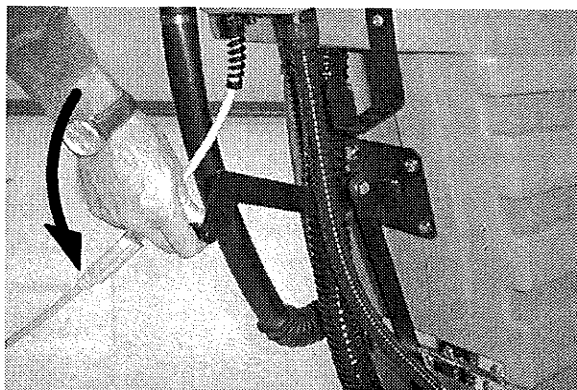

FIG. 3

3. To begin cleaning, hold down the brush/spray button and push machine forward at a pace of approximately 23 m (75 ft) per minute. For heavily soiled areas, push machine at a slower pace (Figure 4).

**⚠ WARNING: Flammable materials or reactive metals can cause explosion or fire. Do not pick up.**

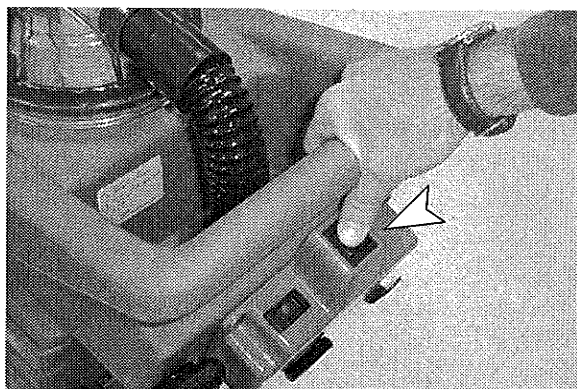

FIG. 4

4. Release button at end of path and continue to push machine forward to pick up excess solution.
5. After cleaning, perform the daily maintenance instructions.

**NOTE:** Allow up to one hour for carpet to dry. Use air movers to reduce drying time.

**WHILE OPERATING**

1. If necessary, adjust brush height to accommodate type of carpet (See ADJUSTING BRUSH HEIGHT).
2. Overlap each path by 51 mm (2 in).
3. Work away from wall outlet and power cord to prevent cord damage.
4. When turning machine around, release spray/brush button, push down on handle and pivot machine on rear wheels.
5. Check for excessive foam buildup in recovery tank. Use a recommended foam control solution to prevent motor damage.

**ATTENTION: Foam will not activate the float shut-off screen. Motor damage due to foam or water is not covered by warranty.**

6. When the float shut-off screen is activated, water pickup will stop. Drain recovery tank at this point and refill solution tank (See DRAINING TANKS).
7. If brush or vacuum motor should stop, circuit breaker may have tripped. Shut off machine, unplug power cord and check for any obstructions. Let motor cool and manually reset circuit breaker button, located under switch box.
8. Raise brush/vacuum head when transporting machine to draining area.

**ACCESSORY TOOL CLEANING**

See Options.

1. Disconnect vacuum hose from recovery dome and connect accessory vacuum hose (Figure 5).
2. Connect accessory solution hose to quick coupler, located in front of handle (Figure 5).

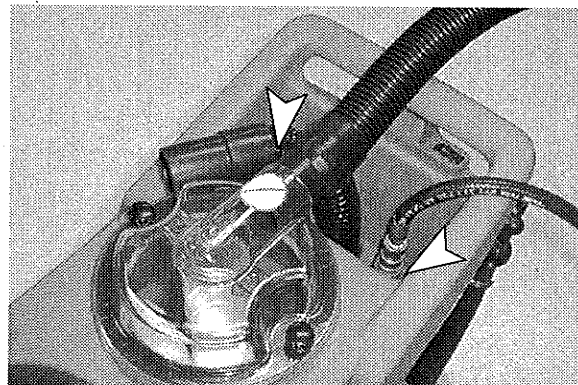

FIG. 5

3. Attach desired accessory tool to hoses.
4. Turn on main power switch.

## OPERATION

5. Begin operating accessory tool (Figure 6).

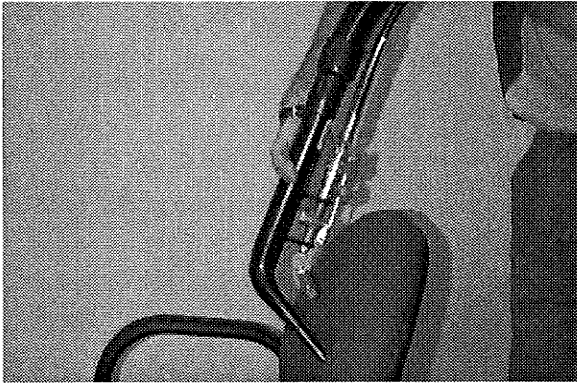

FIG. 6

**NOTE:** When cleaning upholstery, always check cleaning instructions sewn in furniture by manufacturer.

6. After operating accessory tool, relieve water pressure from tool before disconnecting hose. Squeeze trigger for five seconds after turning off switches.

## ADJUSTING BRUSH HEIGHT

1. Turn off machine and unplug power cord from wall outlet.

**FOR SAFETY:** Before leaving or servicing machine, turn off machine and unplug cord from wall outlet.

2. To adjust brush height, use a standard screwdriver and turn brush height adjustment lever in 1/4 turn increments, 4 settings (Figure 7).

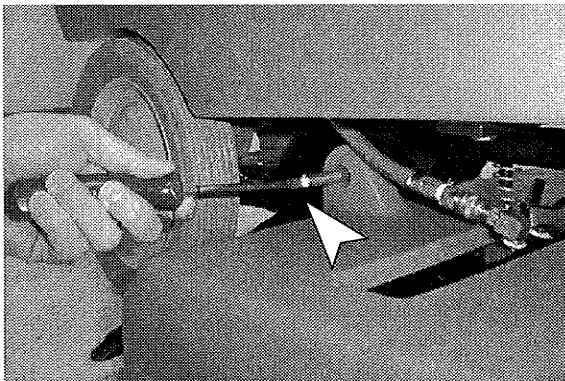

FIG. 7

## DRAINING TANKS

**FOR SAFETY:** Before leaving or servicing machine, turn off machine and unplug cord from wall outlet.

**NOTE:** Always use separate buckets when draining and filling machine.

## DRAINING RECOVERY TANK

1. Turn off power switch and unplug power cord. Raise brush lift handle and transport machine to draining area.
2. Turn drain hose knob counterclockwise and pull plug out to drain (Figure 8).

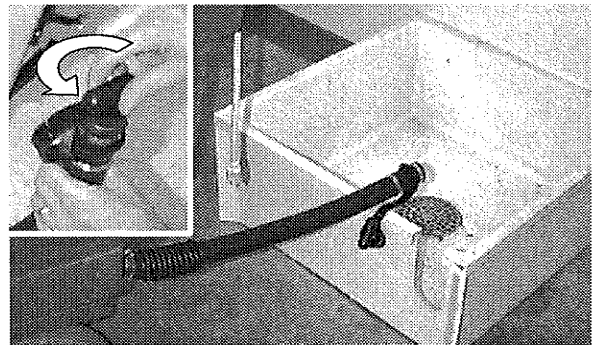

FIG. 8

3. After draining, replace drain hose knob securely.

## DRAINING LEFTOVER CLEANING SOLUTION

1. Connect 1 m (3 ft) pump-out hose, supplied with machine, to machine's solution coupler (Figure 9).

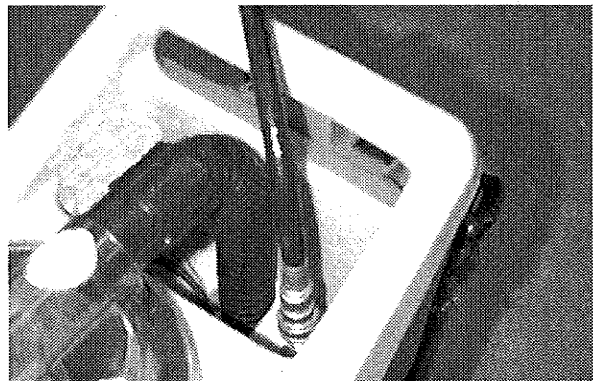

FIG. 9

2. Direct the hose into a bucket or floor drain.
3. Turn on main power switch.

**NOTE:** You can also use the pump-out hose to rinse out recovery tank when there's leftover water.

## MACHINE MAINTENANCE

To keep machine in good working condition, simply follow machine's daily, weekly and monthly maintenance procedures.

**FOR SAFETY: When servicing machine, unplug cord from wall outlet.**

### DAILY MAINTENANCE (Every 4 Hours of Operation)

1. Rinse out recovery tank and recovery dome thoroughly after every use.
2. Remove float shut-off screen and clean. Screen is located in recovery tank (Figure 10).



FIG. 10

3. Vacuum out any leftover solution from solution tank, using the 1 m (3 ft) clean-out hose.
4. Remove and rinse off bladder tank screen.
5. Remove any entangled carpet fibers and debris in brush.
6. Remove any clogged debris in vacuum head.
7. Clean machine with an all purpose cleaner and damp cloth.
8. Coil power cord neatly and store on cord hook.

### WEEKLY MAINTENANCE (Every 20 Hours of Operation)

1. Inspect vacuum hose for holes and loose cuffs.
2. Inspect spray pattern for plugging. If plugged, remove spray tips and soak in acetic acid solution for up to six hours. Do not use pointed objects to unplug tips, damage will occur.
3. Inspect pigtail cord, cord grip and detachable power cord for damage. Replace immediately if damaged.

### MONTHLY MAINTENANCE (Every 80 Hours of Operation)

1. Flush pump system with an acetic acid solution to dissolve normal alkaline chemical buildup. Follow instructions below:
  - a. Premix .5 L (16 oz) of an acetic acid solution with 7.5 L (2 gal) of hot water, 60° C (140° F) maximum, and pour into solution tank.
  - b. Turn on main power switch.
  - c. Position brush/vacuum head over floor drain and activate the brush/spray button for one minute.
  - d. Shut off machine and allow remaining solution to break down alkaline buildup overnight.
  - e. Next day, spray out remaining solution and flush system with 11 L (3 gal) of clean water.
2. Lubricate wheels and caster with a water resistant oil.
3. Inspect machine for water leaks.
4. Inspect machine for loose screws.

### QUARTERLY MAINTENANCE (Every 250 Hours of Operation)

Inspect vacuum motor for carbon brush wear. Replace brushes when worn to a length of 10 mm (0.38 in) or less. Contact Service Center for carbon brush inspection.

**⚠ WARNING: Hazardous Voltage. Shock or electrocution can result. Always unplug machine before servicing.**

### SERVICING MACHINE

**ATTENTION: Machine repairs must be performed by Authorized Personnel only.**

To access internal components for repair:

1. Remove screw from lift handle linkage as shown, 0.5 inch wrench required (Figure 11).

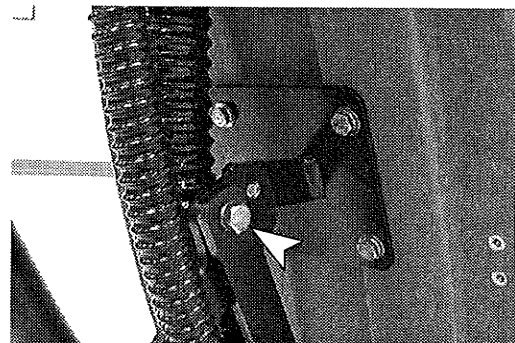

FIG. 11

# OPERATION

- Remove two hex-head bolts at front of machine, 9/16" wrench required.
- Hinge tank backwards away from chassis (Figure 12).

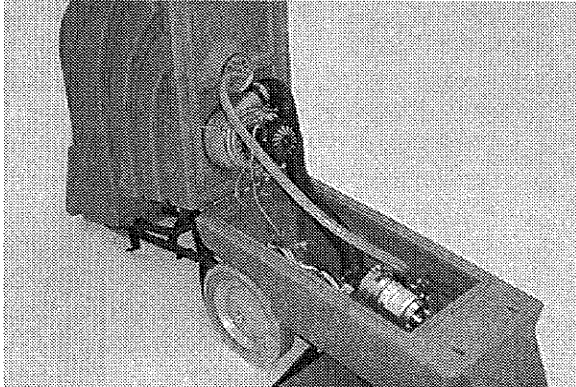

FIG. 12

- When closing machine, be careful not to pinch internal hoses or wiring.

## STORING MACHINE

- Before storing machine, be certain to flush tanks and drain machine of all water.

- Store machine in a dry area in the upright position with brush/vacuum head raised off floor.
- Remove recovery dome to promote air circulation.

**ATTENTION: Do not expose to rain. Store indoors.**

**ATTENTION: If storing machine in freezing temperatures, be sure that machine, pump and spraying system are completely drained and dry. Damage due to freezing temperatures is not covered by warranty.**

## RECOMMENDED STOCK ITEMS

Refer to Parts List section for recommended stock items. Stock Items are clearly identified with a bullet preceding the parts description. See example below:

Ref.	Part No.	Description	Qty.
1	701103	ASM., STANDPIPE	1
2	180619	• FLOAT, SHUTOFF	1
3	230187	NIPPLE	1
4	101714	• GASKET	1
5	210240	NUT, FLANGED	1

## TROUBLE SHOOTING

PROBLEM	CAUSE	SOLUTION
Machine does not operate.	Faulty main power switch or wiring.	Contact Service Center.
	Tripped machine circuit breaker.	Reset circuit breaker.
	Faulty power cord.	Contact Service Center.
	Building circuit breaker tripped.	Reset breaker.
Solution pump does not operate.	Overheated pump.	Determine cause, wait 20 minutes for pump to cool and reset breaker.
	Faulty solution pump.	Contact Service Center.
	Faulty solenoid.	Contact Service Center.
	Faulty brush/spray switch.	Contact Service Center.
	Loose or broken wiring.	Contact Service Center.
Vacuum motor does not operate.	Vacuum motor thermal overload tripped.	Check air flow for obstruction and wait 20 minutes for motor to cool.
	Loose or broken wiring.	Contact Service Center.
	Faulty main power switch.	Contact Service Center.
	Defective vacuum motor.	Contact Service Center.
	Worn carbon brushes.	Replace brushes or call for service.

**TROUBLE SHOOTING - Continued**

PROBLEM	CAUSE	SOLUTION
Brush motor does not operate.	Brush motor circuit breaker tripped.	Remove brush obstruction. Reset brush breaker button at bottom of switch box.
	Brush/spray button not pressed.	Push brush/spray button.
	Faulty brush motor.	Contact Service Center.
	Loose or broken brush belt.	Contact Service Center.
	Faulty switch or wiring.	Contact Service Center.
Poor pick up.	Loose drain hose plug.	Cap drain hose securely.
	Full recovery tank.	Drain recovery tank.
	Clogged float shut-off screen.	Remove recovery dome and clean lint off screen.
	Air leakage around recovery dome.	Tighten recovery dome knobs or replace gaskets.
	Loose vacuum hose connections.	Secure connections.
	Defective vacuum hose.	Replace hose.
	Loose vacuum hose cuffs.	Secure cuffs to hose.
	Clogged vacuum head.	Dislodge debris from vacuum head.
	Pushing machine too fast.	Slow down cleaning process.
Uneven or no spray.	Dirty or plugged spray tips.	Clean or replace tips.
	Improper spray tip size or spray angle.	Replace with proper tips.
	Worn spray tips.	Replace spray tips.
	Solution tank low or empty.	Refill solution tank.
	Faulty solution pump.	Contact Service Center.
	Plugged solution tank filter.	Clean filter.

**SPECIFICATIONS**

Model	Frontier™ Carpet Extractor
LENGTH	1180 mm (46.5 in)
WIDTH	510 mm (20 in)
HEIGHT	940 mm (37 in)
WEIGHT	54 Kg (120 lbs)
CLEANING PATH WIDTH	510 mm (20 in)
SOLUTION TANK CAPACITY	38 ltr (10 gal)
RECOVERY TANK CAPACITY	55 ltr (14.5 gal)
SOLUTION PUMP	120 volt, 100 psi/6.9 bar, 1 amp
SPRAY NOZZLES	5- 80015 Quickjet
VACUUM MOTOR	120 volt, 3-stage, 1.8 hp, 13 amp, 1560 watts
SEALED WATER LIFT	3.5 m (137 in)
BRUSH MOTOR	120V, .1 hp, 1800 rpm, .75 A, 90 W
POWER CORD LENGTH	23 m (75 ft)
TOTAL POWER CONSUMPTION	120V, 14.2 A, 1710 W
DECIBEL RATING AT OPERATOR'S EAR, INDOORS ON CARPET	80dB(A)



## RECOVERY TANK GROUP

REF	PART #	DESCRIPTION	QTY.
∇	100103	ASM., LID, ASSEMBLY	1
▲1	100109	LID, OUTER RING ONLY (BLACK)	1
▲2	100105	LID, CENTER ONLY (CLEAR)	1
3	140900	SCREW, 10-24 X 3/4	6
4	602715	BLADDER, 10 GAL. MODEL	1
5	578729	DECAL, READ MANUAL	1
6	602448	STANDPIPE 10 GAL. MODEL	1
7	180613	FLOAT, SHUT-OFF	1
8	606088	NIPPLE	1
9	230159	O-RING, STANDPIPE	1
10	210240	NUT, FLANGED METAL	1
∇11	701005	ASM., DOME	1
▲12	240217	KNOB, DOME	2
▲13	140037	WASHER, NYLON	2
▲14	100042	GASKET, RECOVERY DOME	1
▲15	120399	DECAL, DO NOT ALLOW FOAM	1
∇	701061	ASM., DRAIN HOSE	1
▲16	230831	KNOB, DRAIN HOSE	1
▲17	230882	STRAP	1
▲18	140056	WASHER, FENDER	1
▲19	140955	PLUG	1
20	140921	SLEEVE, DRAIN HOSE	1

REF	PART #	DESCRIPTION	QTY.
21	140072	CLAMP	2
22	160416	HOSE, DRAIN	1
23	140307	CLAMP	1
24	230696.BK	BRACKET, DRAIN HOSE	1
25	140825	SCREW, #6X3/4	2
26	230843	BRACKET, TANK BRACE W/ THREADS	1
27	230844	BRACKET, TANK BRACE W/HOLES	1
28	140259	SCREW, 1/4-20X5/8	1
29	230955	CLAMP	1
30	140553	SCREW, 1/4-20X1/2	1
31	140016	WASHER, LOCK	2
32	140000	WASHER, FLAT	8
33	102569	TANK, GASKET	2
34	140227	STUD, 1/4-20X5	3
35	608472	DECAL, FRONTIER	2
36	608186	DECAL, "NOBLES"	1
37	608532	TANK, RECOVERY GREEN	1
38	630420	DECAL, FLAMMABLE MATERIAL	1
39	603547	HOSE, VAC 1-1/2 X 51" W/CUFFS	1
40	120906	DECAL, IMPORTANT DRAIN	1

∇ ASSEMBLY

▲ INCLUDED IN ASSEMBLY

CONTROL CONSOLE GROUP

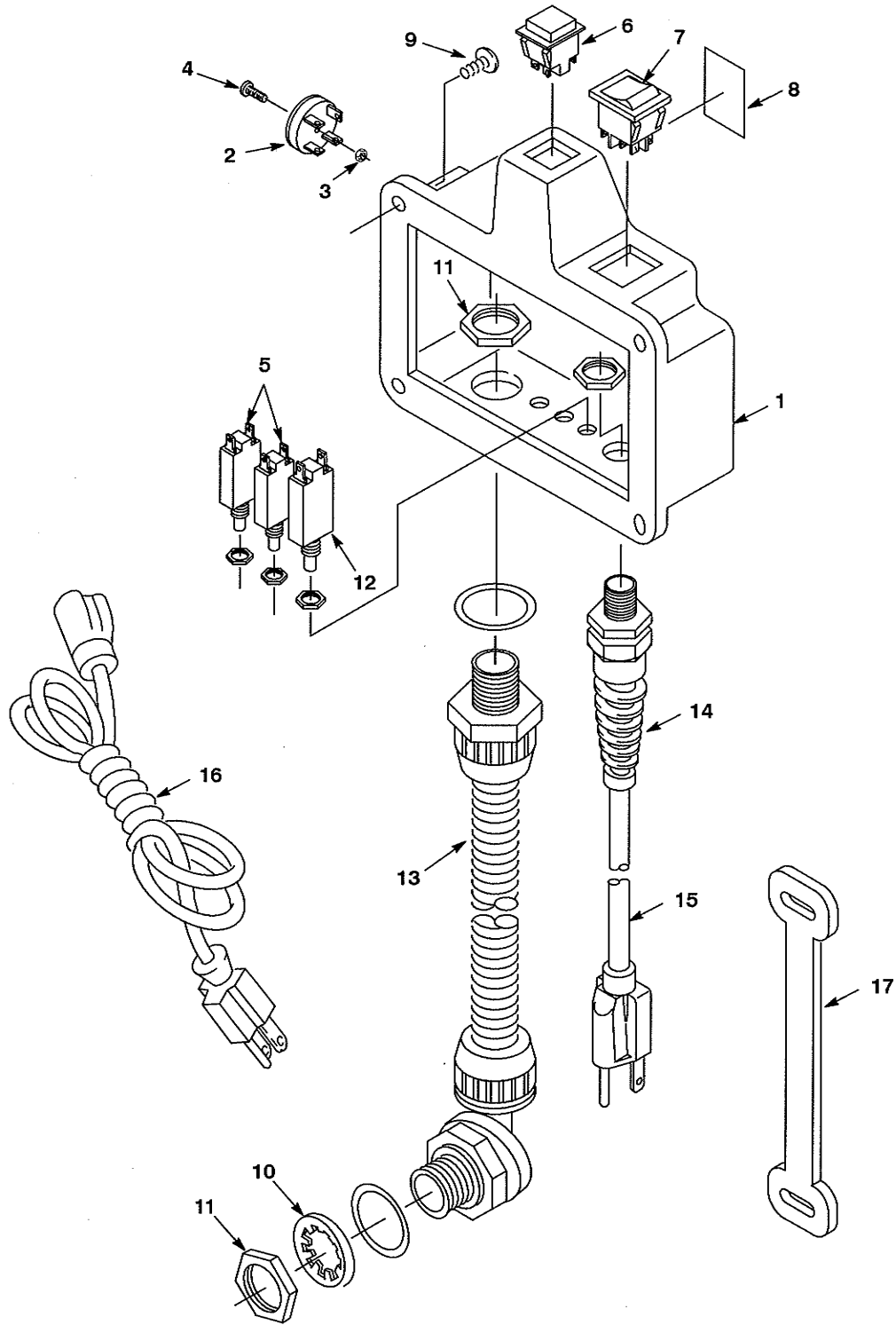

## CONTROL CONSOLE GROUP

REF	PART #	DESCRIPTION	QTY.
1	608537	ASM, SWITCHBOX GREEN (120V)	1
2	130304	●RECTIFIER, MINIBRIDGE 600V	1
3	140534	NUT, NYLON	1
4	140879	SCREW, 6-32X3/4	1
5	578337000	●BREAKER, CIRCUIT 1.5A (120V)	2
	130747	BREAKER, CIRCUIT 1.2A (220V)	1
6	130441	●SWITCH, PULSE (120V)	1
	130716	SWITCH, PULSE (220V)	1
7	130717	●SWITCH, ROCKER (120V)	1
	130764	SWITCH, ROCKER (220V)	1
8	120619	DECAL, WARNING EXTRACTOR	1

REF	PART #	DESCRIPTION	QTY.
9	140824	SCREW 1/4-20X5/8	4
10	140044	WASHER 13/16 INT	1
11	140504	NUT, CONDUIT	2
12	130670	●BREAKER, CIRCUIT 12AMP (120V)	1
13	130977	HARNESS, WIRE	1
14	130166	●GRIP, CORD (120V)	1
	130137	GRIP, CORD (220V)	1
15	130237	●CORD, 16/3X18" YELLOW (120V)	1
	130662	CORD, 18/3X24" BLACK (220V)	1
16	130229	CORD, 14/3 X 75' YELLOW SMOOTH	1
17	604393	STRAP, CORD STRAIN RELIEF	1

● RECOMMENDED STOCK ITEMS

CHASSIS GROUP

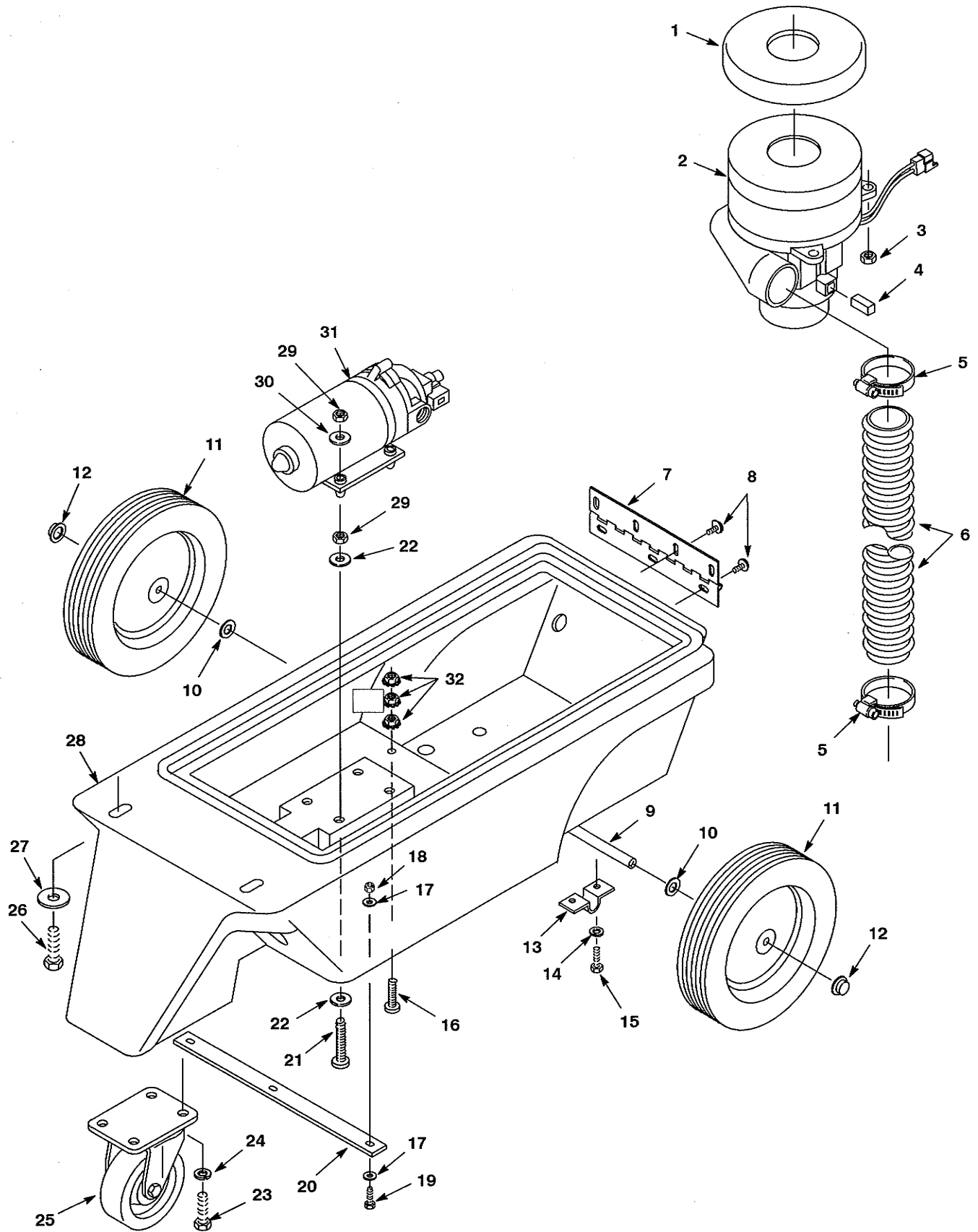

## CHASSIS GROUP

REF	PART #	DESCRIPTION	QTY.
1	100118	●GASKET, VAC MOTOR 120V	1
	100038	GASKET, VAC MOTOR 220V	1
2	130996	●MOTOR, VAC 120V	1
	603042	COVER, VAC FAN 120V	1
	130403	MOTOR, VAC 240V	1
3	140501	NUT 1/4-20 NYLOCK	4
4	600177	●BRUSH, CARBON 2/PK 120V	2
	190158	BRUSH, CARBON 2/PK 220V	2
5	140308	CLAMP, HOSE 1-5/16 TO 2-1/4	2
6	069 760 778	HOSE, EXHAUST 2" X 31.5"	1
7	230390	HINGE, TANK	1
8	140885	SCREW, 1/4-20X1/2 TRSPHL	7
9	230739	AXLE	1
10	140008	WASHER, 1/2" FLAT	2
11	103068	WHEEL, 10" X 1.75"	2
12	103019	CAP, HUB	2
13	230746	BRACKET, AXLE OFF SET	2
14	140016	WASHER, 1/4 LOCK	4
15	140259	SCREW, 1/4-20X5/8 HXHDCP	4

REF	PART #	DESCRIPTION	QTY.
16	140804	SCREW 10-24X1	1
17	140000	WASHER, 1/4 FLAT	6
18	140501	NUT, 1/4-20 NYLOCK	3
19	140208	SCREW, 1/4-20X1	3
20	604640	BRACKET, CHASSIS SUPPORT	1
21	140899	SCREW 10-24X1-1/4	4
22	140011	WASHER, 3/16 FLAT	8
23	140226	SCREW, 5/16-18X3/4 HXHDCP	4
24	140015	WASHER, 5/16 SPLITLOCK	4
25	103065	●CASTER, SWIVEL 4"	1
26	140256	SCREW, 3/8-16XX2-1/2	2
27	140028	WASHER, FLAT	2
28	608831	CHASSIS, GREEN	1
29	140519	NUT, 10-24 KEP	8
30	140012	WASHER, 3/16 FLAT	4
31	180103	PUMP,100PSI 120V	1
	180109	PUMP,100PSI 230V	1
32	140519	NUT, 10-24 KEP	3

● RECOMMENDED STOCK ITEMS

BRUSH BASE GROUP

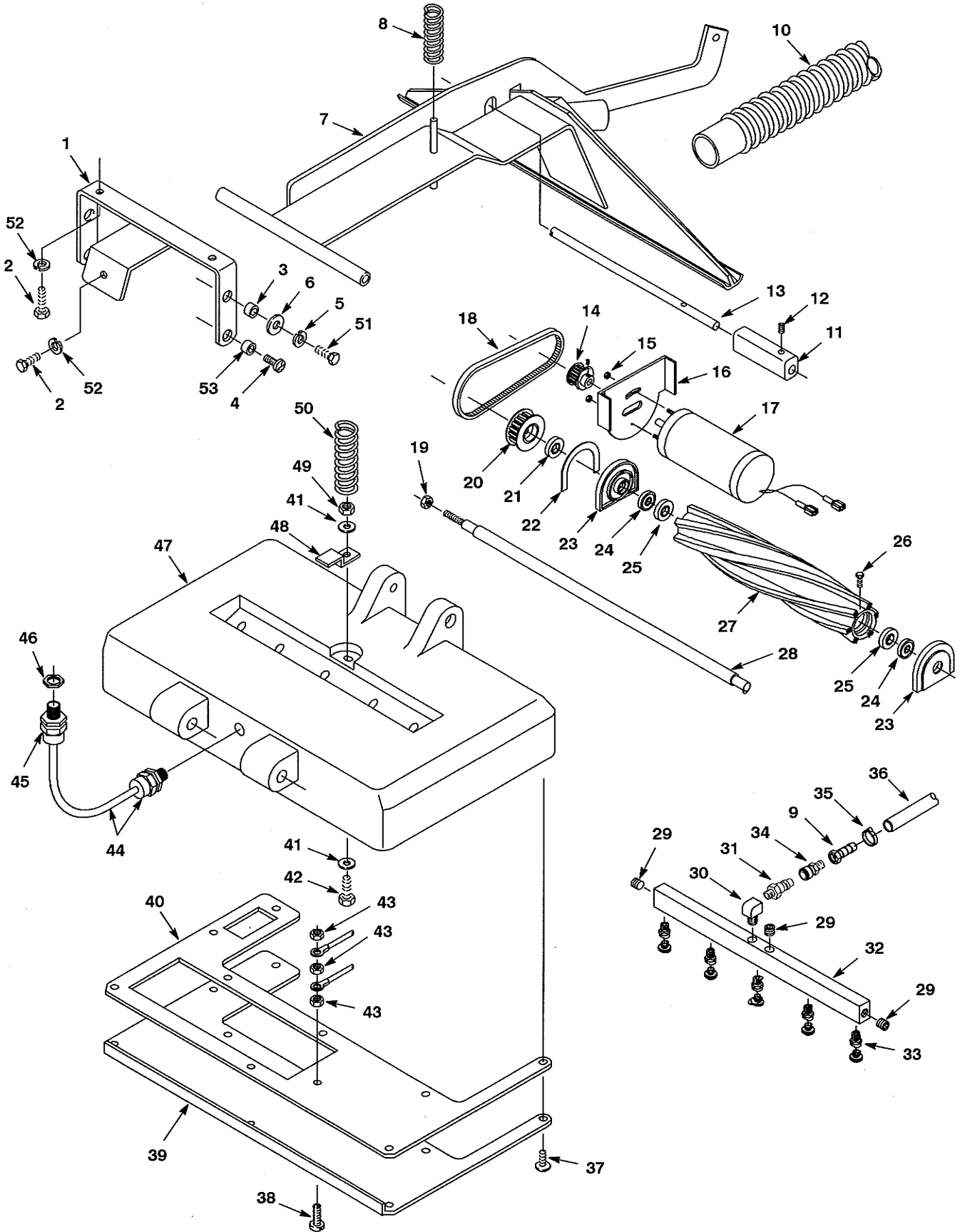

## BRUSH BASE GROUP

REF	PART #	DESCRIPTION	QTY.
1	603175	BRACKET, MOUNT	1
2	140226	SCREW, 5/16-18X5/8 HXHDCP	3
3	140136	BUSHING, 3/8ID X 1/2OD	2
4	140898	SCREW, 3/8-16X3/4 TRSPHL	2
5	140017	WASHER, 3/8 SPLITLOCK	2
6	140028	WASHER, 3/8 FLAT	2
7	603184	TOOL, PICKUP W/LEVER	1
8	603448	SPRING, TOOL PRESSURE	1
9	150520	FITTING, 1/8FX1/4H BARB	1
10	603547	HOSE, VACUUM 1-1/2X46"	1
11	603178	CAM ADJUSTER	1
12	140859	SCREW, SET 1/4-20X1/4	1
13	603177	LEVER, CAM ADJUSTER	1
14	230506	●PULLEY, MOTOR	1
15	140518	NUT, KEP 10-32	2
16	230366	PLATE, MOTOR MOUNT	1
17	130471	●MOTOR, BRUSH DRIVE 120V	1
	190150	●BRUSH, CARBON	1
	130472	MOTOR, BRUSH DRIVE 220V	1
18	230507	●BELT, BRUSH DRIVE	1
▽	500094	ASM, BRUSH 20"	1
▲19	140548	NUT, 5/16 FINJAM	1
▲20	230505	●PULLEY, BRUSH	1
▲21	230363	SPACER	1
▲22	100005	●GASKET, BEARING BLOCK	1
▲23	230261	●BLOCK, BEARING	2
▲24	140125	●BEARING, BRUSH	2
▲25	100049	●SEAL, BRUSH BEARING	2
▲26	140554	SCREW, 1/4-20X3/4	4
▲27	240050	●BRUSH, CYLINDER 20" BASE	1
▲28	230362	●SHAFT, BRUSH 20" BASE	1

REF	PART #	DESCRIPTION	QTY.
▽	606844	ASM, SPRAYBAR 20"	1
▲29	150208	FITTING, 1/8M PLUG	3
▲30	150430	FITTING 1/8MX1/4F ELBOW	1
▲31	150921	●FITTING 1/8M QD CPLR BRS	1
▲32	230379	MANIFOLD, SPRAYBAR 20"	1
▲33	201011	●FITTING, 80015 NOZZLE TWIST-OUT	5
34	150915	●FITTING, 1/8 QD CPLR BRS	1
35	140325	CLAMP, EAR 1/2"	1
36	606453	HOSE, 1/4" X 1.25' LP GRAY	1
37	140887	SCREW, 10-24X3/8	12
38	140900	SCREW, 10-24X3/4	1
39	230367.BK	PLATE, BRUSH BASE 20"	1
40	100115	GASKET, 20" PWR BRSH BASE	1
41	140028	WASHER, 3/8 FLAT	2
42	140233	SCREW, 3/8-16X1-3/4 HXHDCP	1
43	140519	NUT, KEP	3
44	603561	CORD, 18/3 X 24" BLACK	1
45	130181	CORD GRIP (FOR SERVICE ONLY)	1
46	140504	NUT, CONDUIT	1
47	604494	BASE BRUSH 20" BLACK	1
48	606712	LATCH, SPRAYBAR	1
49	140515	NUT, 3/8-16 NYLOCK	1
50	140407	SPRING, .845OD	1
51	140201	SCREW, 3/8-16X3/4	2
52	140015	WASHER, 5/16 SPLTLCK	3
53	140914	SPACER, .38X.50X.25	2

▽ ASSEMBLY

▲ INCLUDED IN ASSEMBLY

● RECOMMENDED STOCK ITEMS

# PARTS LIST

## PLUMBING GROUP

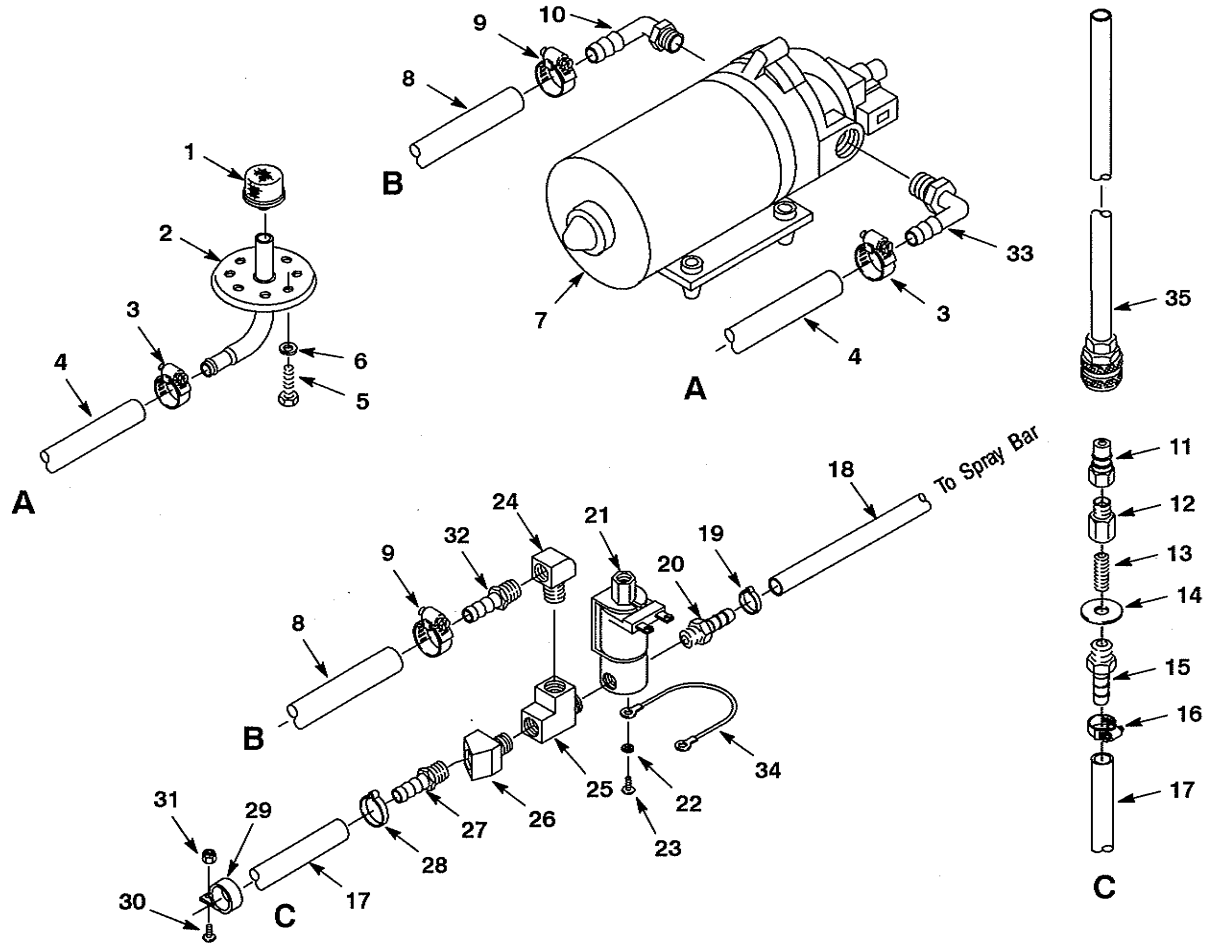

REF	PART #	DESCRIPTION	QTY.
1	180628	●SCREEN, TANK	1
2	600451	BLADDER PLATE	1
3	140310	CLAMP	2
4	606452	HOSE, 3/8" X 2.75' LP GRAY	1
5	140259	SCREW	4
6	140016	WASHER, LOCK	4
7	180103	●PUMP, 100PSI, 120V	1
	180109	PUMP, 100PSI, 220V/240V	1
8	606162	HOSE, 1/2" X 26"	1
9	630369	CLAMP	2
10	150425	ELBOW, 3/8M X 1/2H	1
11	150933	QUICK COUPLER	1
12	150000	ADAPTER, 1/4FX1/4M	1
13	150600	NIPPLE, 1/4 X 2 - BRASS	1
14	140008	WASHER, FLAT	1
15	150511	FITTING, BARB 1/4FX3/8H	1
16	140310	CLAMP	1
17	606451	HOSE, 3/8" X 4.33' LP	1
18	606453	HOSE, 1/4" X 1.25' LP	1
19	140325	CLAMP, EAR 1/2" S/S	2

REF	PART #	DESCRIPTION	QTY.
20	150515	FITTING, BARB 1/4MX1/4H	1
21	210033	●VALVE, SOLENOID 120V 60HZ	1
	210036	VALVE, SOLENOID 220V 50HZ	1
	210037	VALVE, SOLENOID 100V 50HZ	1
	210260	VALVE, SOLENOID 240V 50HZ	1
22	140023	WASHER, LOCK	2
23	140801	SCREW, 8-32X3/8	2
24	150406	ELBOW, 1/4"	1
25	150709	TEE, 1/4"	1
26	150403	FITTING, 1/4MX1/4F ELBOW 45°	1
27	150516	FITTING, BARB 1/4MX3/8H	1
28	140301	CLAMP, EAR	1
29	140916	CLAMP	1
30	140895	SCREW, 10-24X3/4	1
31	140552	NUT, LOCK	3
32	150517	FITTING, BARB 1/4MX1/2H	1
33	150412	ELBOW, 3.8MX3/8H	1
34	700551	ASM., WIRE GROUND 9" 10X10	1
35	700141	HOSE, PUMP-OUT	1

● RECOMMENDED STOCK ITEMS

PUMP BREAKDOWN

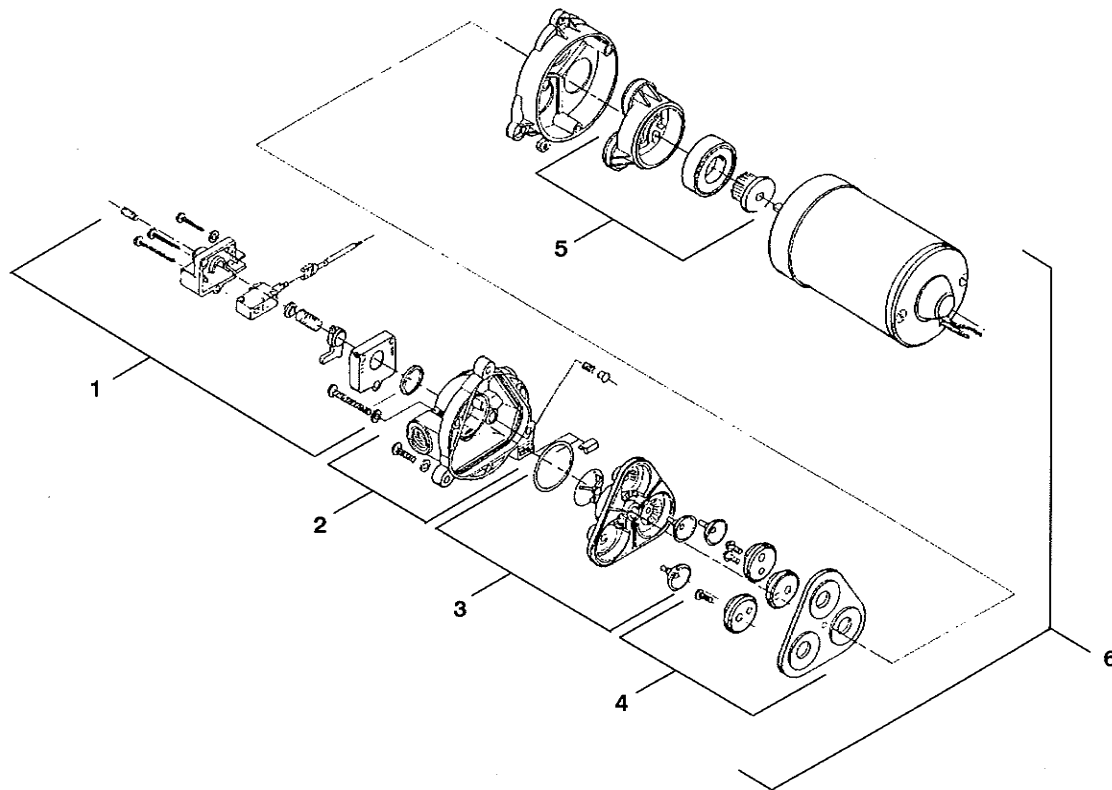

REF	PART #	DESCRIPTION	QTY.
1	190129	KIT, PRESSURE SWITCH	1
	190172	KIT, PRESSURE SWITCH (VITON)	1
	190134	KIT, DIAPHRAGM ONLY	1
2	190128	KIT, UPPER PUMP HOUSING	1
	190124	KIT, CHECK VALVE ONLY	1

REF	PART #	DESCRIPTION	QTY.
3	190171	KIT, VALVE (VITON)	1
4	190131	KIT, SERVICE	1
5	190130	KIT, LOWER PUMP HOUSING	1
6	180103	PUMP, 100 PSI 120V	1
	180109	PUMP, 100 PSI 240V	1

# PARTS LIST

## REAR HOUSING GROUP

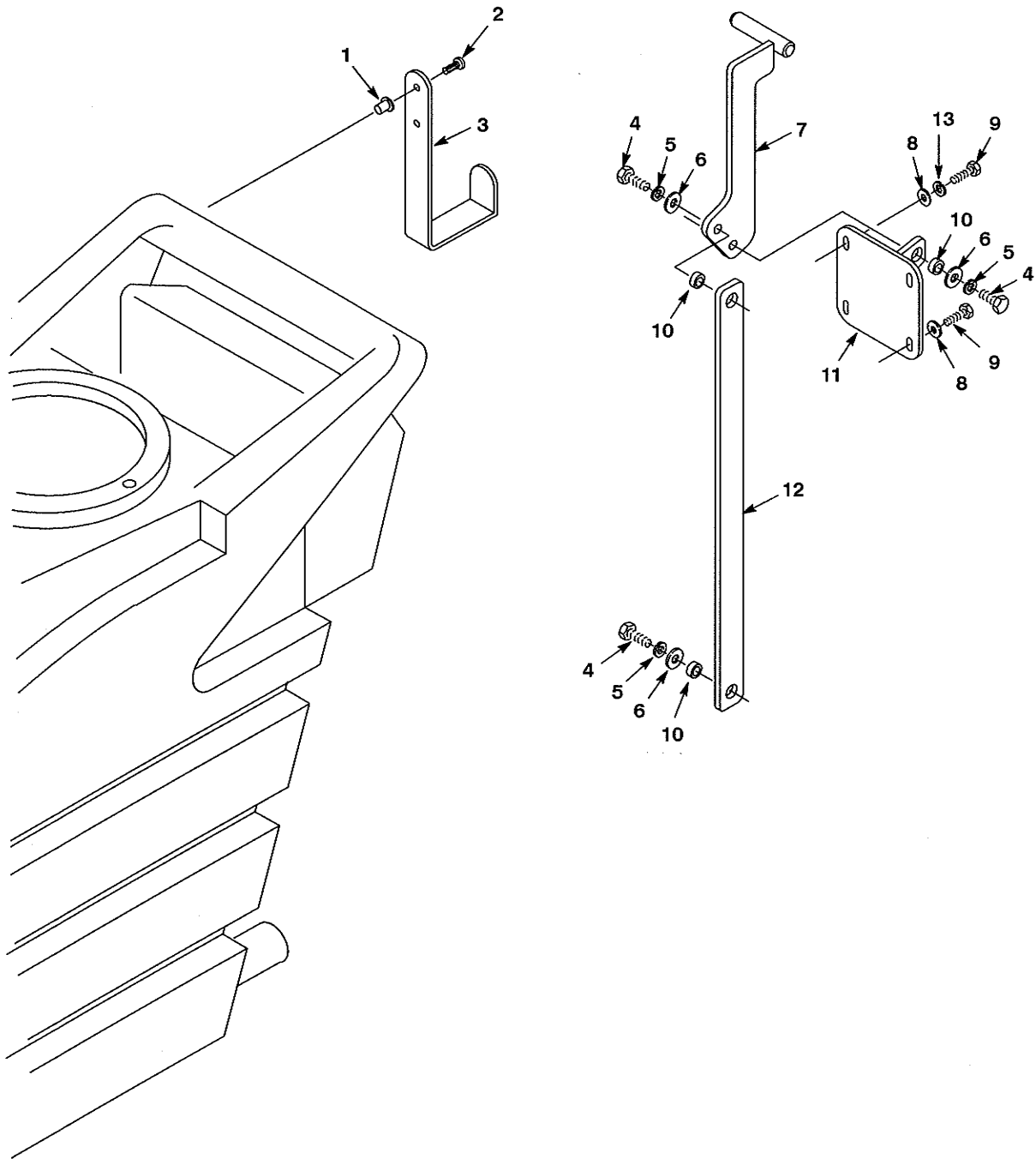

REF	PART #	DESCRIPTION	QTY.
1	140637	NUT, WELL 10-32	2
2	140887	SCREW, 1024X3/8 PANPHL	2
3	230755.BK	BRACKET, CORD HANGER BLACK	1
4	140226	SCREW, 5/16 18X5/8 HXHDCP	3
5	140015	WASHER, 5/16 SPLITLOCK	3
6	140027	WASHER, 5/16 FLAT	3
7	603414	HANDLE, LIFT	1

REF	PART #	DESCRIPTION	QTY.
8	140000	WASHER, FLAT	4
9	140259	SCREW, 1/4-20X5/8	4
10	603415	BUSHING, PIVOT	3
11	603413	BRACKET, LIFT MOUNT	1
12	603412	PLATE, LIFT	1
13	140016	WASHER, LOCK	4

# ELECTRICAL DIAGRAM

## 120V WIRING

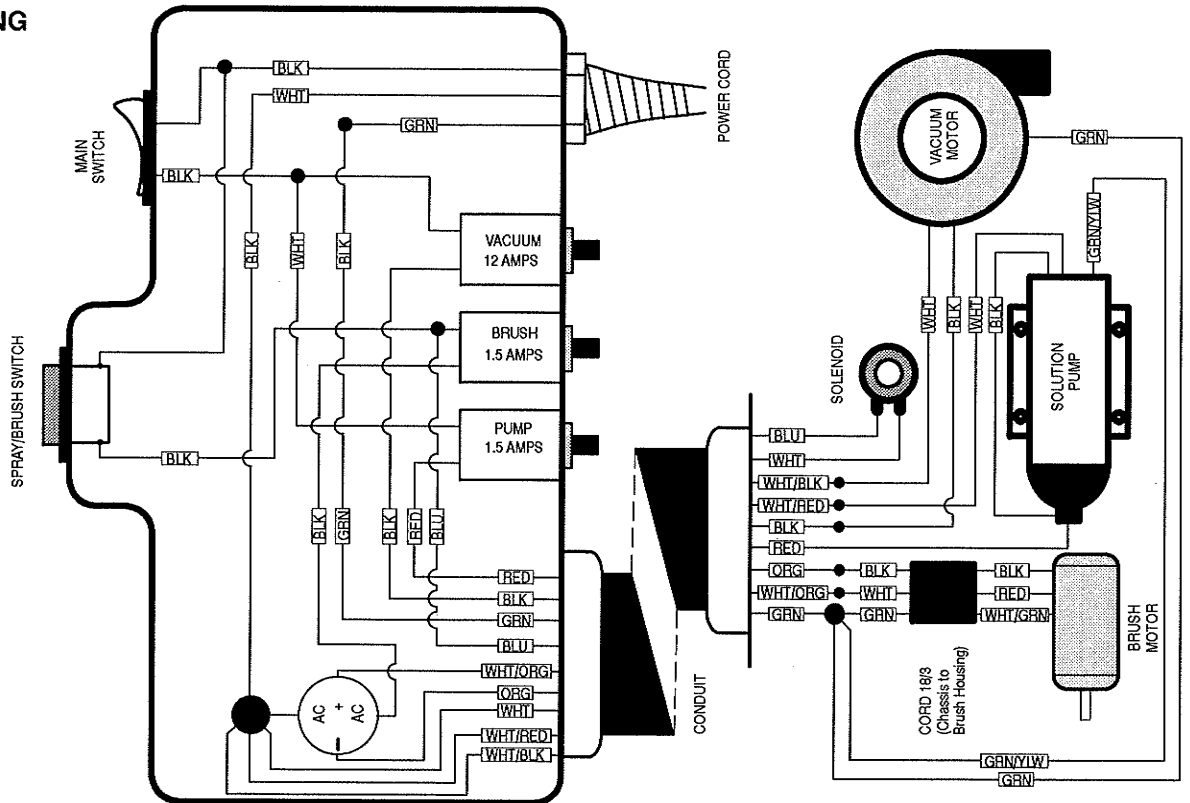

## 220V WIRING

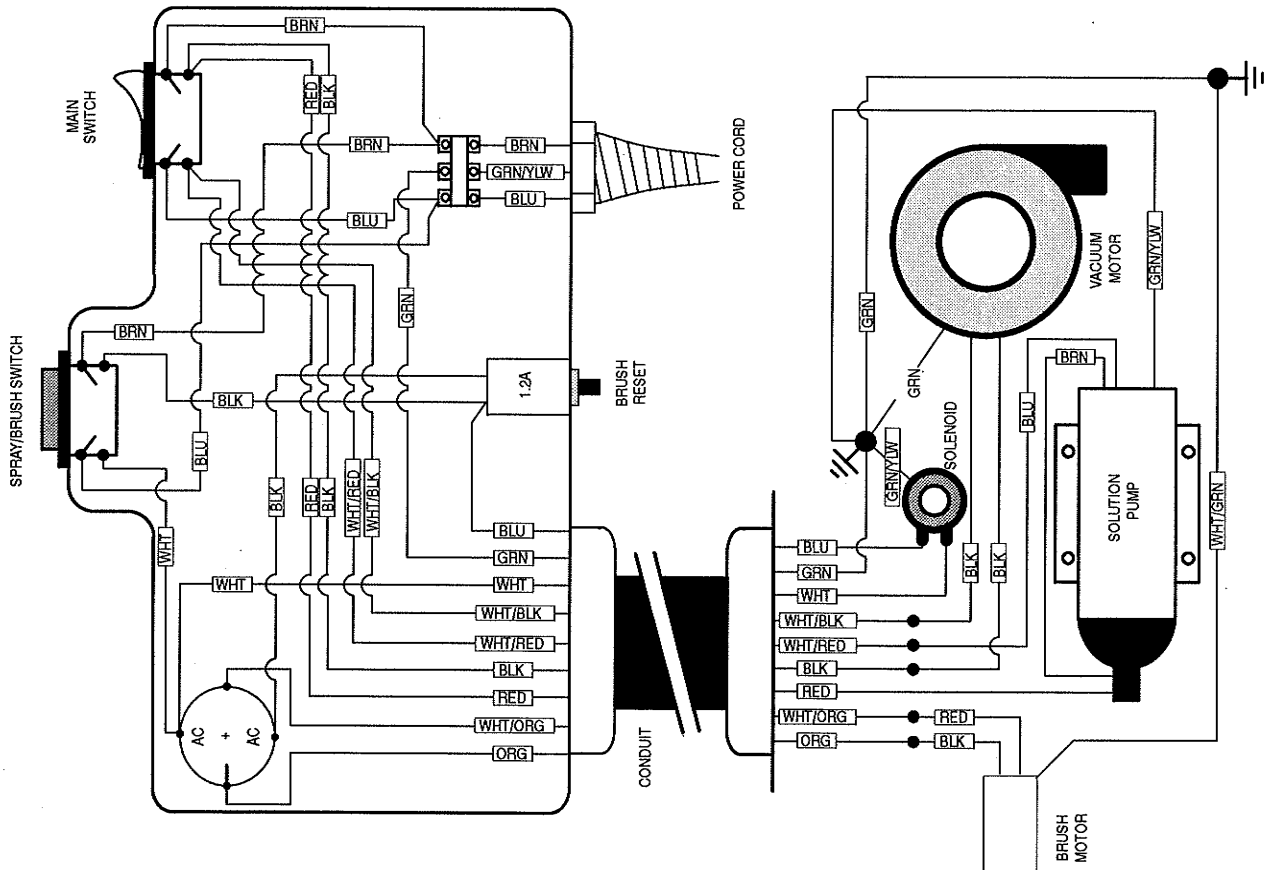

**127 mm (5 in) HAND TOOL**

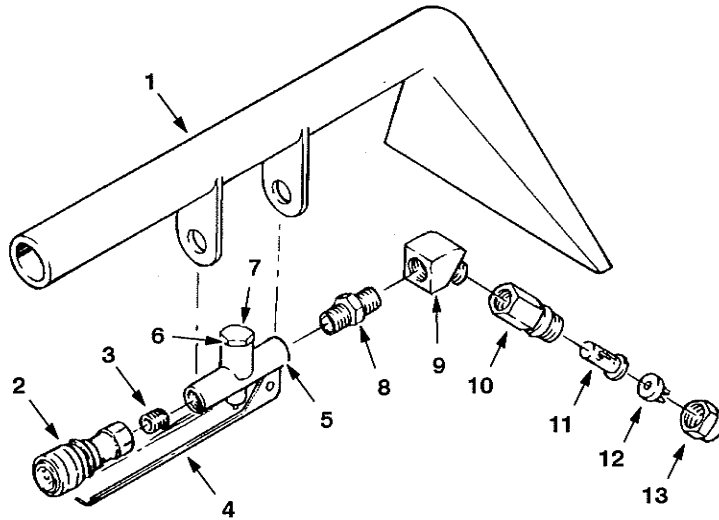

REF	PART #	DESCRIPTION	QTY.
	200505	TOOL, HAND (COMPLETE)	1
1	200431.BK	TOOL, HAND	1
2	150913	COUPLER, QUICK (SER. 60)	1
3	150615	NIPPLE, CLOSE	1
4	200905	TRIGGER, HAND TOOL	1
5	210210	VALVE, FLOW CONTROL	1
6	190600	VALVE PIN & SPRING (NOT SHOWN)	1

REF	PART #	DESCRIPTION	QTY.
7	N/A	CAP, VALVE	1
8	150606	NIPPLE, HEX 1/4	1
9	150403	ELBOW, ST 1/4 45°	1
10	200992	BODY, SPRAY 1/4F	1
11	200996	SCREEN, SPRAY NOZZLE	1
12	200965	TIP, SPRAY #8002	1
13	20094	CAP, SPRAY BODY	1

**SOLUTION AND VACUUM HOSES**

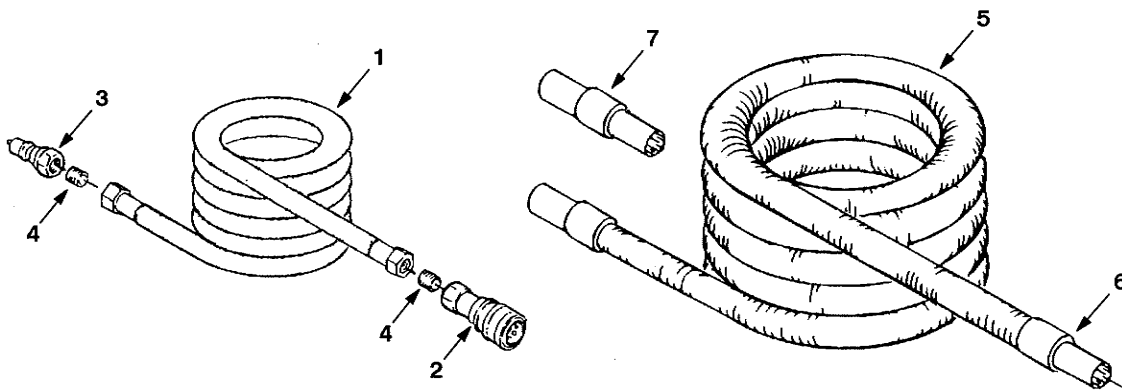

REF	PART #	DESCRIPTION	QTY.
▽1	160185	HOSE, SOLUTION 4.6M (15 FT)	1
	160186	HOSE, SOLUTION 7.6M (25 FT)	1
	160187	HOSE, SOLUTION 15M (50 FT)	1
▲2	150913	COUPLER, QUICK SER. 60	1
▲3	150933	PLUG, QUICK COUPLER	1
▲4	150615	NIPPLE	2

REF	PART #	DESCRIPTION	QTY.
▽5	160400	HOSE, VACUUM 4.6M (15 FT)	1
	160401	HOSE, VACUUM 7.6M (25 FT)	1
	160402	HOSE, VACUUM 15M (50 FT)	1
▲6	160430	CUFF, HOSE 1-1/2"	2
7	160451	CONNECTOR, VACUUM HOSE 1.5"	1

▽ ASSEMBLY  
▲ INCLUDED IN ASSEMBLY

FLOOR TOOL

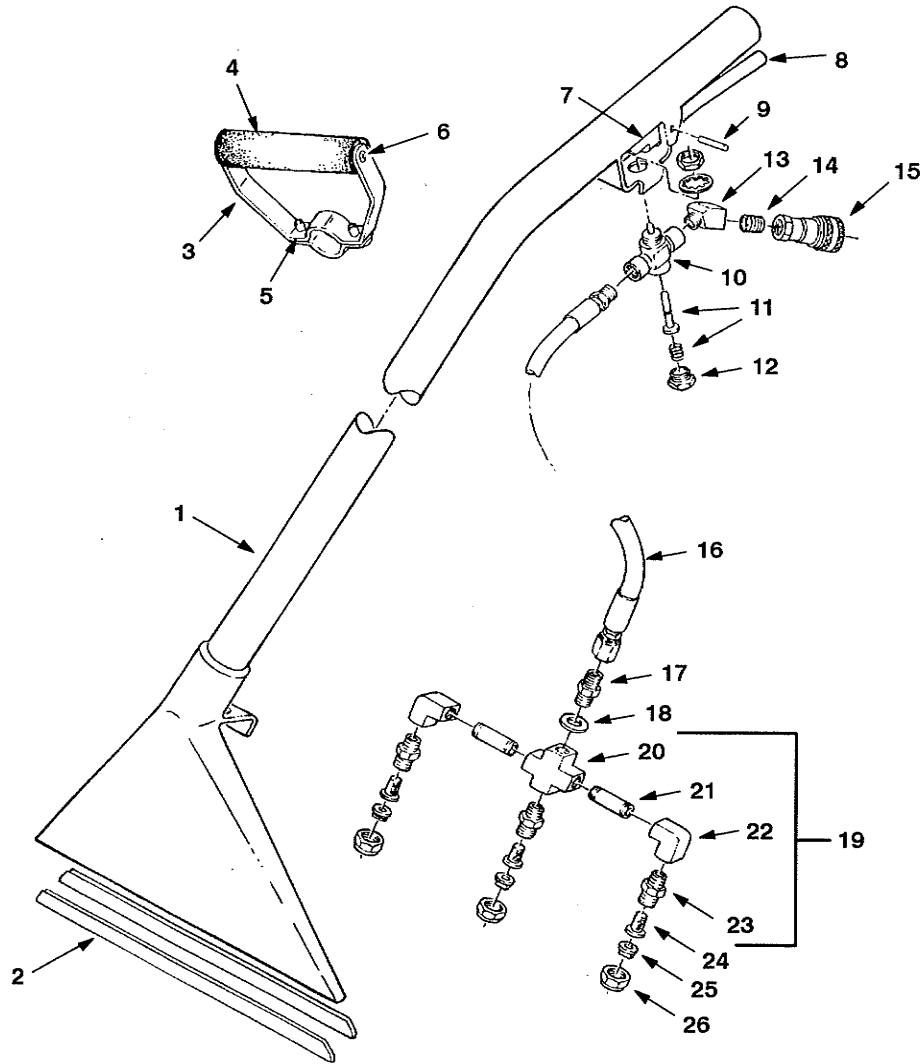

REF	PART #	DESCRIPTION	QTY.
	600048	FLOOR TOOL (COMPLETE)	1
1	200403.BK	TOOL, FLOOR	1
2	200939	SHOES, FLOOR TOOL	2
▽3	200927	GRIP, ADJUSTABLE	1
▲4	200912	FOAM, GRIP	1
▲5	140259	SCREW, 1/4X3/4	2
▲6	140834	SCREW, 1/4-20X5/8	2
7	200902	TRIGGER, FLOOR TOOL	1
8	200809	SLEEVE, TRIGGER	1
9	140605	PIN	1
	140520	NUT, PUSH (NOT SHOWN)	2
10	210150	VALVE, FLOW CONTROL	1
11	190603	KIT, VALVE PIN & SPRING	1
12	N/A	CAP, HEX, VALVE	1
13	150403	ELBOW, 1/4-45°	1

REF	PART #	DESCRIPTION	QTY.
14	150615	NIPPLE, CLOSE 1/4	1
15	150913	COUPLER, QUICK SER. 60	1
16	160170	HOSE, 1/4 HP W/ SWEDGE	1
17	150606	NIPPLE, HEX 1/4"	1
18	140058	WASHER	1
▽19	700062	ASM., SPRAY BAR	1
▲20	150700	CROSS	1
▲21	150600	NIPPLE	2
▲22	150401	ELBOW, 90° 1/4FX1/4F	2
▲23	200993	SPRAY BODY	3
24	200996	SCREEN, SPRAY BODY	3
25	200964	TIP	3
26	200994	CAP, SPRAY BODY	3

▽ ASSEMBLY  
 ▲ INCLUDED IN ASSEMBLY

