



Electronic Service Manuals

This electronic document is provided as a service to our customers. We do not create the contents of the information contained in this document. Should you have detailed questions pertaining to the information contained in this document, you may contact Michco, or the manufacturer which provided the original information in this electronic deliverable. Michco's only part in this electronic deliverable was the electronic assembly process.

You may contact Michco through the following methods:
Phone (517) 484-9312 or (800) 331-3339 MI, OH, IN only
2011 N. High St. -- Lansing, Michigan -- 48906
Fax: (517) 484-9836
Email: CustServ@Michco.com
Web site: www.Michco.Com
Parts Web site: www.FloorMachineParts.Com

Order Parts on Line at:
www.FloorMachineParts.Com

Directly to Parts & Service:
By Email: **Shop@Michco.com**
By Fax: (517) 702-2041
By Voice: Use numbers above.

Serving the Cleaning Industry Since 1922

Notice: All copyrighted material remains property of original owners, all trademarks are property of respective owners. Manuals are subject to Manufacturer's reproduction limitations. Originals or reproductions were provided by manufacturers through a request. We make no warranty as to the correctness of information provided in this document and you assume all risk.

Brake Drum Cover Assembly w/Gloves

Model No: 807010

■ OPERATION ■ SERVICE ■ PARTS ■ CARE

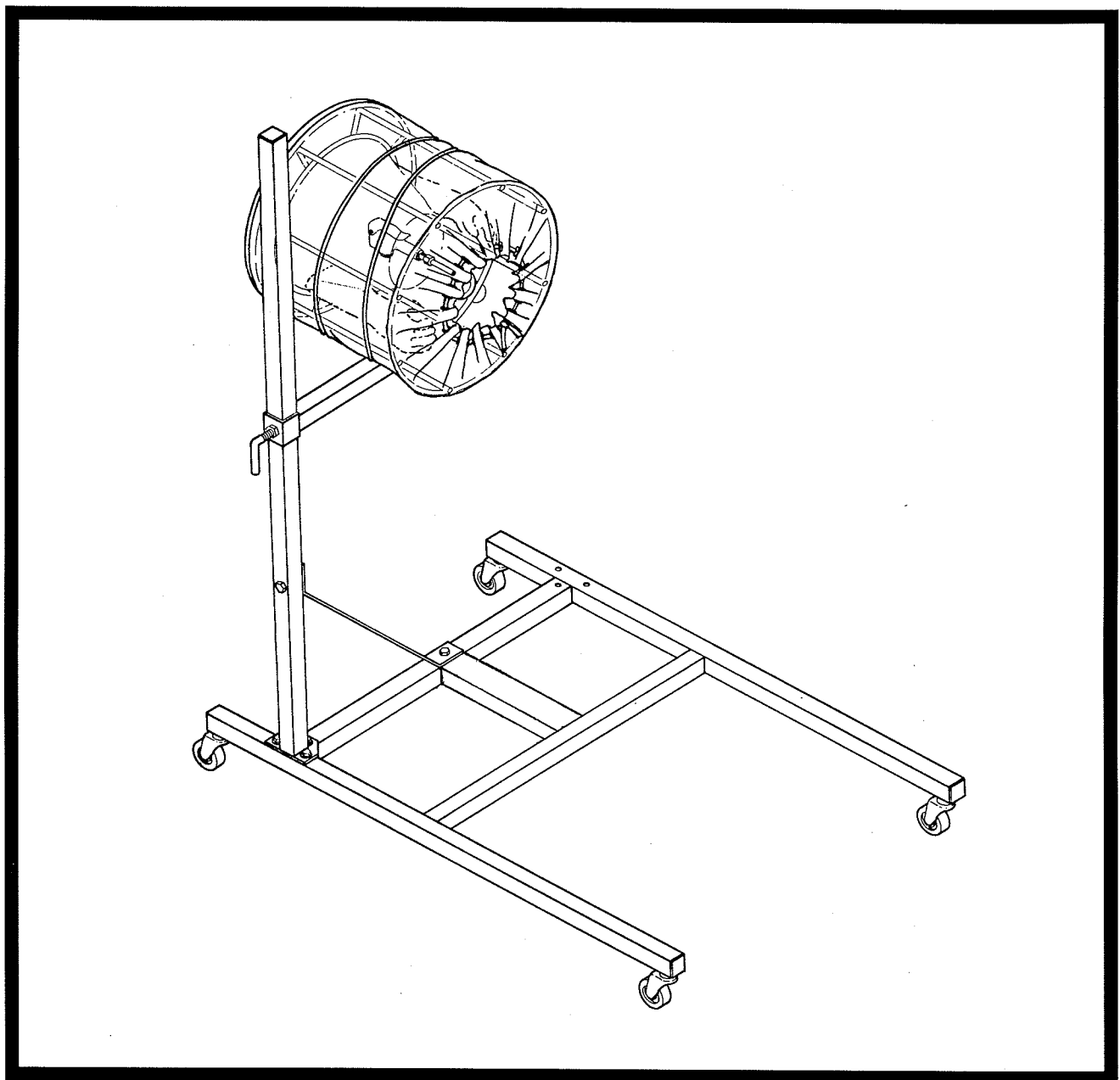

Revised 1/95

Minuteman[®]

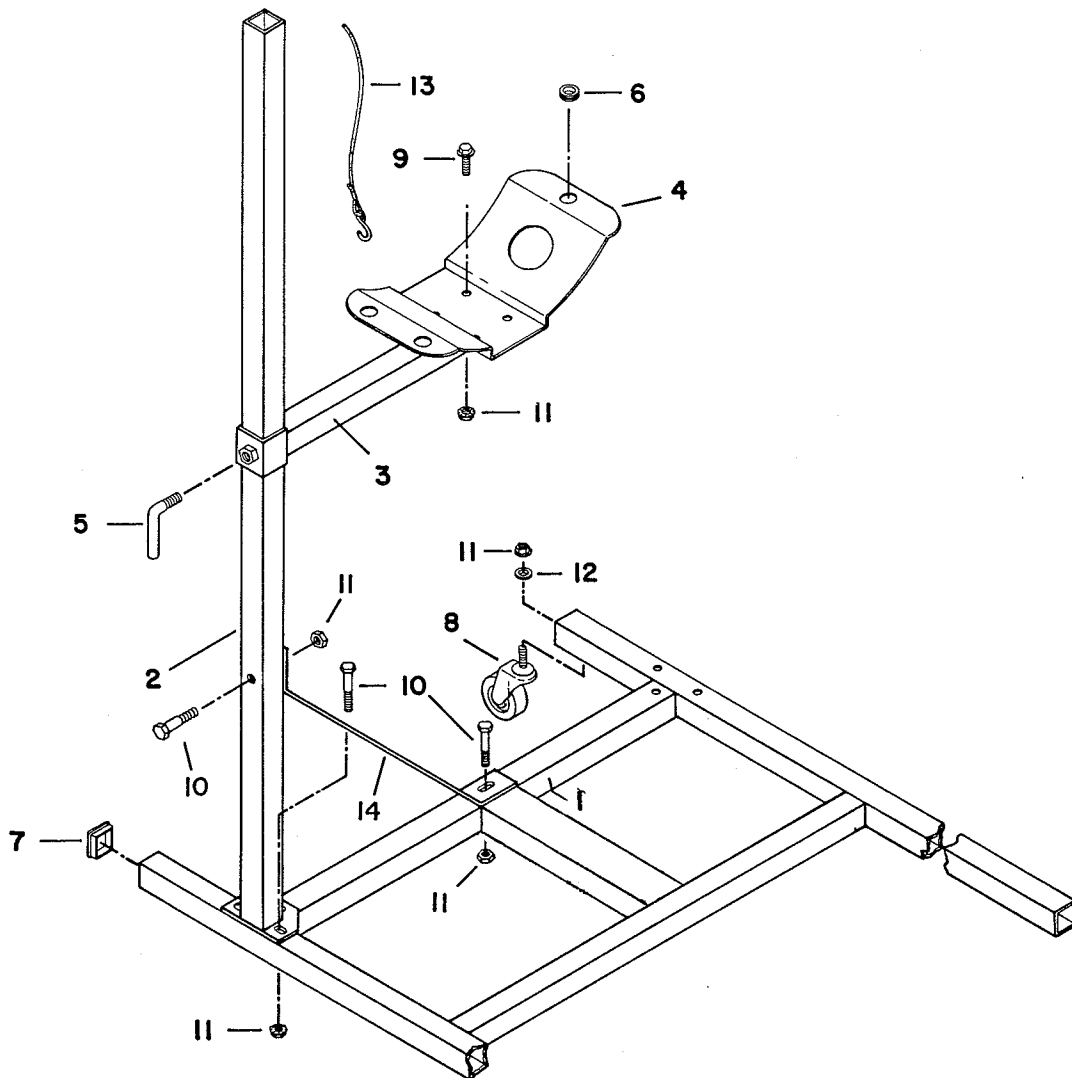

BRAKE DRUM CLEANER STAND COMPLETE 807006

ITEM NO.	PART NO.	QTY.	DESCRIPTION
1	750019	1	Base Weldment (807006)
2	750020	1	Column Weldment (807006)
3	750021	1	Frame Support Weldment
4	760016	1	Frame Hold Down
5	760047	1	Handle Loc Bolt
6	762299	3	Grommet .50 x.09 x .75
7	760051	6	End Cap for 807006
8	760019	4	Caster Wheel 1.62 Diameter
9	712042	4	Bolt HH 5/16-18 x .62 SP
10	711233	5	BLT-?H 5/16-18 x 1.75 ST PL
11	711379	13	Flanged Whiz Nut 1/16-18
12	711506	4	WSR-Flat 5/16 ST PL
13	807001	1	Cord, Shock with S-Hooks
14	807007	1	Strut Brace

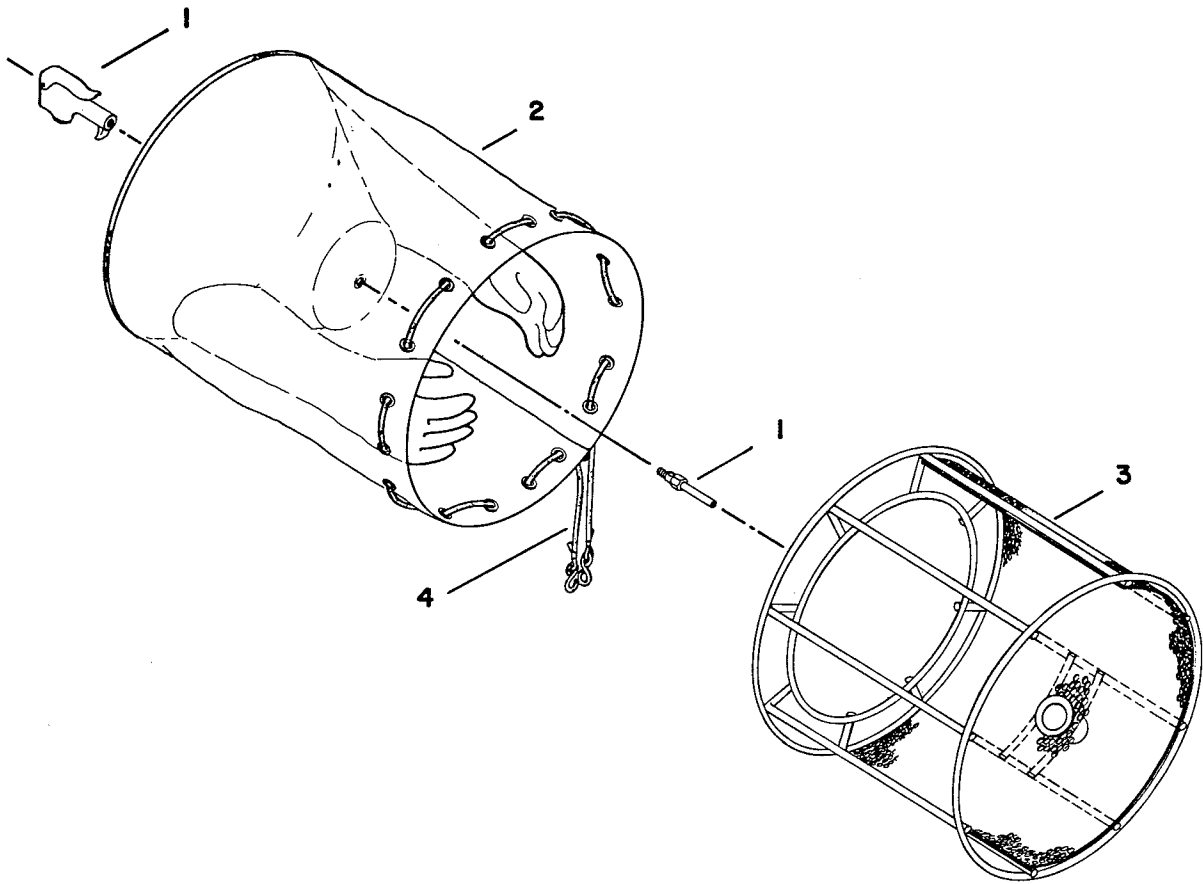

**BRAKE DRUM COVER ASSEMBLY COMPLETE
LARGE (12"-19" diameter) 807010**

ITEM NO.	PART NO.	QTY.	DESCRIPTION
1	807003	1	Air Gun
2	807009	1	Cover, Vinyl Large
3	807008	1	Frame, Large
4	807002	1	Cord with S-Hooks Long

OPERATING INSTRUCTIONS
MODEL #807010 BRAKE DRUM CLEANER WITH GLOVES (U.S. PATENT NO. 4,712,270)
AND
MODEL #C80315 - 15 GALLON ASBESTOS RECOVERY VACUUM

Assemble the brake drum stand according to diagram enclosed in carton. Attach brake drum hood assembly onto the adjustable arm so the aperture opening is over the center of the wheel bracket.

The hood assembly is mounted on the cleaner stand with two bungee cords pulled over the top and fastened to the plate. The vacuum hose will be attached to the tube on the hood on the underside of the adjustable arm.

With the hood assembly elevated to about 30" in height, the asbestos recovery vacuum can be placed on the brake drum stand and transported as a unit.

The brake drum assembly hood #807010 is equipped with two heavy-duty rubber gloves sewn into the unit. This will enable the operator to use a hammer or other tools to help dislodge the brake drum when necessary.

A quick coupler air hose is connected to the air jet at the back of the hood assembly. Do not connect the air hose until you are ready to use it. The hood assembly is adjustable to the working elevation from ground level to 60" high.

After removing the wheel from the automobile, roll the stand and hood assembly up to the brake unit on which you will be working. Remove the vacuum from the stand and roll it about 5 feet away. Attach the vacuum hose to the inlet on the hood.

Elevate the hood assembly to center the brake unit. Place onto the plate inside the hood assembly all the tools you may need to remove the brake drum. Plug in the vacuum electric cord and turn on vacuum.

Loosen the bungee cord around the aperture opening to its fullest opening, then roll the stand in toward the brake assembly until it is centered and inside the hood. Draw the bungee cord as much as possible to close the aperture opening. Hook the bungee cord to one of the holes in the frame base.

Insert your hands into gloves and remove the brake drum for the brake assembly. Place the brake drum flat on the base of the hood. Connect the air pressure line to the air jet in the hood assembly and blow the dust from the brake assembly and the brake drum. Using a circular motion, blow the dust that may be left around the inside of the hood itself, then blow out the brake assembly again to be sure you have removed all traces of dust. This should take about two minutes. Maximum air pressure 50 PSI through 1/4" - 3/8" air line.

Disconnect the air hose, release the bungee hooks from the stand, open the aperture around the brake assembly, and pull back the stand. Turn off the vacuum. Remove brake drum from hood assembly and place it on your worktable. Proceed with brake shoe relining.

The collector bag in your vacuum will hold approximately six gallons of dry bulk material. This could mean as many as 200 brake jobs before it needs to be cleaned out. To check the efficiency of your vacuum, disconnect the hose from the tank. Turn on the vacuum. Completely choke off the hose intake and listen to the motor noise. When the motor noise increases, the vacuum is operating efficiently. When the motor noise does not increase, it is time to release the collector bag and filters.

LIMITED WARRANTY

Minuteman International, Inc. warrants to the original purchaser/user that this product is free from defects in workmanship and materials under normal use and service for a period of three years from date of purchase. In addition, Minuteman International, Inc. will, at its option, honor labor warranty claims for the first 12 months from date of sale, provided such claims are submitted through and approved by factory authorized repair stations. Minuteman International, Inc. will, at its option, repair or replace without charge, except for transportation costs, parts that fail under normal use and service when operated and maintained in accordance with the applicable operation and instruction manuals.

This warranty does not apply to normal wear, or to items whose life is dependent on their use and care, such as belts, cords, switches, hoses, rubber parts, electrical motor components or adjustments. Parts not manufactured by Minuteman International, Inc. such as engines, batteries, battery chargers, hydraulic pumps, and tires are covered by and subject to the warranties and/or guarantees of their manufacturers. Please contact Minuteman International, Inc. for procedures in warranty claims against these manufacturers.

Special warning to purchaser -- Use of replacement filters and/or prefilters not manufactured by Minuteman International, Inc. or its designated licensees, will void all warranties expressed or implied.

A potential health hazard exists without exact original equipment replacement.

All warranted items become the sole property of Minuteman International, Inc. or its original manufacturer, whichever the case may be.

Minuteman International, Inc. disclaims any implied warranty, including the warranty of merchantability and the warranty of fitness for a particular purpose. Minuteman International, Inc. assumes no responsibility for any special, incidental or consequential damages.

This limited warranty is applicable only in the U.S.A. and Canada, and is extended only to the original user/purchaser of this product. Customers outside the U.S.A. and Canada should contact their local distributor for export warranty policies. Minuteman International, Inc. is not responsible for costs or repairs performed by persons other than those specifically authorized by Minuteman International, Inc. This warranty does not apply to damage from transportation, alterations by unauthorized persons, misuse or abuse of the equipment, use of non-compatible chemicals, or damage to property, or loss of income due to malfunctions of the product.

If a difficulty develops with this machine, you should contact the dealer from whom it was purchased.

This warranty gives you specific legal rights, and you may have other rights which vary from state to state. Some states do not allow the exclusion or limitation of special, incidental or consequential damages, or limitations on how long an implied warranty lasts, so the above exclusions and limitations may not apply to you.

Minuteman[®]

World Headquarters
Minuteman International, Inc.
111 South Rohlwing Road
Addison, Illinois 60101

Minuteman Canada, Inc.
2210 Drew Road
Mississauga, Ontario
L5S 1B1

(630) 627-6900
FAX (630) 627-1130

(905) 673-3222
FAX (905) 673-5161

987828
Printed in U.S.A.