



## Electronic Service Manuals

This electronic document is provided as a service to our customers. We do not create the contents of the information contained in this document. Should you have detailed questions pertaining to the information contained in this document, you may contact Michco, or the manufacturer which provided the original information in this electronic deliverable. Michco's only part in this electronic deliverable was the electronic assembly process. By providing this manual on line we are not guaranteeing parts availability.

You may contact Michco through the following methods:

Phone (517) 484-9312 or (800) 331-3339

2011 N. High St. -- Lansing, Michigan -- 48906

Fax: (517) 484-9836

Email: [CustServe@Michco.com](mailto:CustServe@Michco.com)

Web site: [www.Michco.Com](http://www.Michco.Com)

Parts Web site: [www.FloorMachineParts.Com](http://www.FloorMachineParts.Com)

Order Parts on Line at:

**[www.FloorMachineParts.Com](http://www.FloorMachineParts.Com)**

Directly to Parts & Service:

By Email: **[Shop@Michco.com](mailto:Shop@Michco.com)**

By Fax: (517) 702-2041

By Voice: Use numbers above.

**Serving the Cleaning Industry Since 1922**

Notice: All copyrighted material remains property of original owners, all trademarks are property of respective owners. Manuals are subject to Manufacturer's reproduction limitations. Originals or reproductions were provided by manufacturers through a request. We make no warranty as to the correctness of information provided in this document and you assume all risk. By placing these manuals on line we are not declaring our corporation to be an manufacturer authorized dealer or provider, please check our web site for authorized manufacturers we represent.

# **Eagle Power™**

## **Products Group**



## **WET/DRY VACUUMS**

**POLYETHYLENE, POLYPROPYLENE & STEEL**



### **MODELS:**

**315P**

**415P**

**429P**

**415S**

**415ST**

**415PLT**

**429ST**



# **OPERATIONS AND PARTS MANUAL**

**IMPORTANT! READ THIS MANUAL PRIOR TO USE.**

# TABLE OF CONTENTS

	<b>Page No.</b>
Important Safety Instructions .....	1-3
Vacuum and Accessories .....	4
Operation .....	5
Wiring Diagram .....	5
Daily Maintenance .....	5
Periodic Maintenance .....	6
Servicing the Filter and Vac Motor .....	6-7
Vacuum Parts Diagram .....	8-13
Accessories .....	14

---

# IMPORTANT SAFETY INSTRUCTIONS

When using an electrical appliance, basic precaution must always be followed, including the following:

## READ ALL INSTRUCTIONS BEFORE USING THIS MACHINE.

This machine is for commercial use.

## WARNING



**DANGER:** Failure to read and observe all DANGER statements could result in severe bodily injury or death. Read and observe all DANGER statements found in your Owner's Manual and on your machine.



**WARNING:** Failure to read and observe all WARNING statements could result in injury to you or to other personnel; property damage could occur as well. Read and observe all WARNING statements found in your Owner's Manual and on your machine.



**CAUTION:** Failure to read and observe all CAUTION statements could result in damage to the machine or to other property. Read and observe all CAUTION statements found in your Owner's Manual and on your machine.

---



**DANGER:** Failure to read the Owner's Manual prior to operating or attempting any service or maintenance procedure to your machine could result in injury to you or to other personnel; damage to the machine or to other property could occur as well. You must have training in the operation of this machine before using it. If you or your operator(s) cannot read English, have this manual explained fully before attempting to operate this machine.



**DANGER:** Operating a machine that is not completely or fully assembled could result in injury or property damage. Do not operate this machine until it is completely assembled. Inspect the machine carefully before operation. Use only as described in this manual. Use only the manufacturer's recommended attachments.



**DANGER:** Machines can cause an explosion when operated near flammable materials and vapors. Do not use this machine with or near fuels, grain dust, solvents, thinners, or other flammable materials.



**DANGER:** **Do not** pick up flammable fluids, dust or vapors.



**DANGER:** **Do not** vacuum anything that is burning or smoking, such as cigarettes, matches, or hot ashes.



**DANGER:** This machine **is not** suitable for picking up health endangering dust.



**DANGER:** Using a machine with a damaged power cord could result in an electrocution. Do not use the machine if the power cord is damaged. Do not use the electrical cord to move the machine. Keep cord away from heated surfaces. Do not unplug by pulling on the cord; grasp the plug, not the cord. Turn off all controls before unplugging. Do not close a door on cord or pull around sharp edges or corners.



**DANGER:** Electrocutation could occur if maintenance and repairs are performed on a unit that is not properly disconnected from the power source. Disconnect the power supply before attempting any maintenance or service.



**WARNING:** Operating a machine without observing all labels, decals, etc., could result in injury or damage. Read all machine labels before attempting to operate the machine. Make sure all of the labels are attached or fastened to the machine. Get replacement labels and decals from the manufacturer's distributor.



**WARNING:** Electrical components can "short-out" if exposed to water or moisture. Keep the electrical components of the machine dry. Always store the machine in a dry area.



**WARNING:** Use of this machine to move other objects or to climb on could result in injury to the operator or damage to the machine. Do not use this machine as a step or furniture. Do not allow to be used as a toy. Close attention is necessary when used by or near children.



**WARNING:** Moving parts of this machine can cause injury and/or damage. Keep hands, feet, loose clothing, hair, fingers, and all parts of the body away from openings and moving parts.



**WARNING:** Electrocutation could occur if you handle the plug or appliance with wet hands. Do not handle plug or appliance with wet hands.



**WARNING:** The machine employs a removable float for wet pick-up operation to reduce risk of electric shock. Always install float before any wet pick-up operation.



**WARNING:** Rotating fan blades inside the cover. Before opening cover, switch off machine. Wait until the fan/brush stops completely or dust and debris may be ejected.



**WARNING:** If the machine is **not working properly**, has been dropped, damaged, left outdoors, or dropped into water, return it to an Authorized service center.



**WARNING:** Damage could occur to machine if openings are blocked. Do not put any object into openings. Do not use with any opening blocked; keep free of dust, lint, hair, and anything that may reduce air flow.



**WARNING:** Injury could occur to the operator or the machine if used without the dust bag and/or filters. Do not use the machine without the dust bag and/or filters in place.



**WARNING:** Injury to the operator and/or damage to the machine could occur when cleaning on stairs, unless extra caution is used. Use extra caution when cleaning on stairs.



**WARNING:** To reduce the risk of electrical shock, always use a 3-wire electrical system connected to the electrical ground. Whenever possible connect the machine to an outlet protected by a ground fault interrupter (GFCI). See "Grounding Instructions."

**SAVE THESE INSTRUCTIONS**

---

## 120 Volt Machine Instructions For Connection To The Power Supply And The Electrical Ground

This machine must be connected to the electrical ground to protect the operator from electric shock. The machine has an approved power cord with three conductors and a plug with three terminals. Connect the plug to a receptacle that has three holes and is connected to the electrical ground. The green (or green and yellow) conductor in the cord is the ground wire. Never connect this wire to any terminal other than the ground terminal.

This machine uses a 120 volt AC 60 cycle electrical circuit. Make sure you have the correct frequency and voltage before connecting the power cord to an outlet. The machine has a plug as shown in Figure 1. If a receptacle connected to the electrical ground as shown in Figure 1 is not available, have one installed by an electrical contractor. Do not use an adapter.

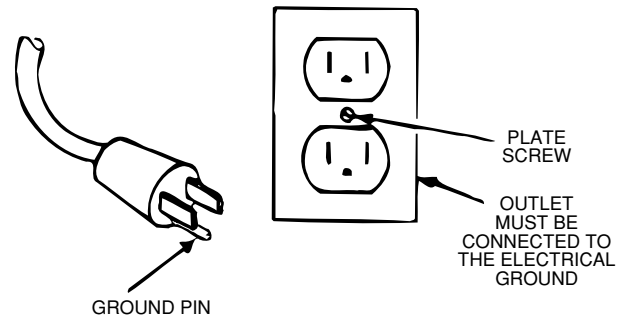

**WARNING:** To reduce the risk of electric shock, protect the machine from rain. Keep the machine in a dry area.



**WARNING:** To reduce the risk of electric shock, always use a 3-wire electrical system connected to the electrical ground. Whenever possible connect the machine to an outlet protected by a ground fault interrupter (GFCI).



**WARNING:** Do not cut, remove or break the ground pin. If the outlet does not fit the plug, consult your electrical contractor.



**WARNING:** Have worn, cut or damaged cords and plugs replaced by an authorized service person.

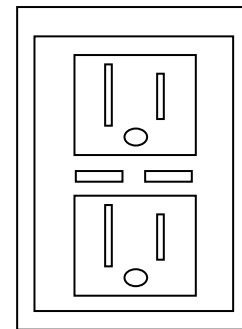

GFCI Outlet

## VACUUM AND ACCESSORIES

- A Motor Block
- B On/Off Switch
- C Float: Keeps liquid out of Motor Block
- D Polyester Filter: Remove for use with liquids
- E Hooks: Secure Motor Block to Tank
- F Suction Inlet
- G Tank
- H 1-pc. Hose End, Bent PVC
- I Hose, 10-ft. x 1-1/2" Flexible
- J 1-pc PVC Wand (2)
- K Adapter
- M Dust Brush
- N Crevice Tool
- O Floor Brush, 16"
- P Squeegee, 16"

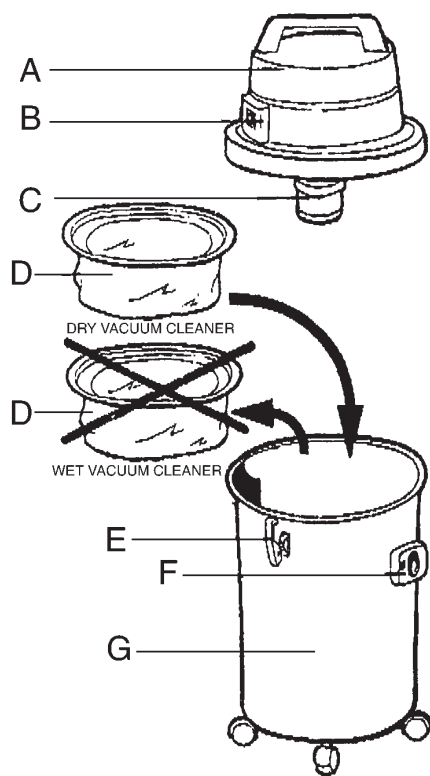

**ATTENTION:** The Polyester Filter must be cleaned after each use to maintain efficient suction.

## IMPORTANT INSTRUCTIONS

- Before use, the equipment must be correctly assembled with all its components.
- Check that electrical outlet is correct for use with the plug on the machine.
- Before connecting, check that the specified motor voltage corresponds to the main voltage available.
- Never use the equipment near inflammable, explosive or toxic substances: sparks from the motor could cause dangerous reactions.
- Always unplug the machine from electrical outlet when leaving machine unattended or before attempting any repair.
- Service and repair should be done by qualified personnel only. Use only original manufacturer's replacement parts.

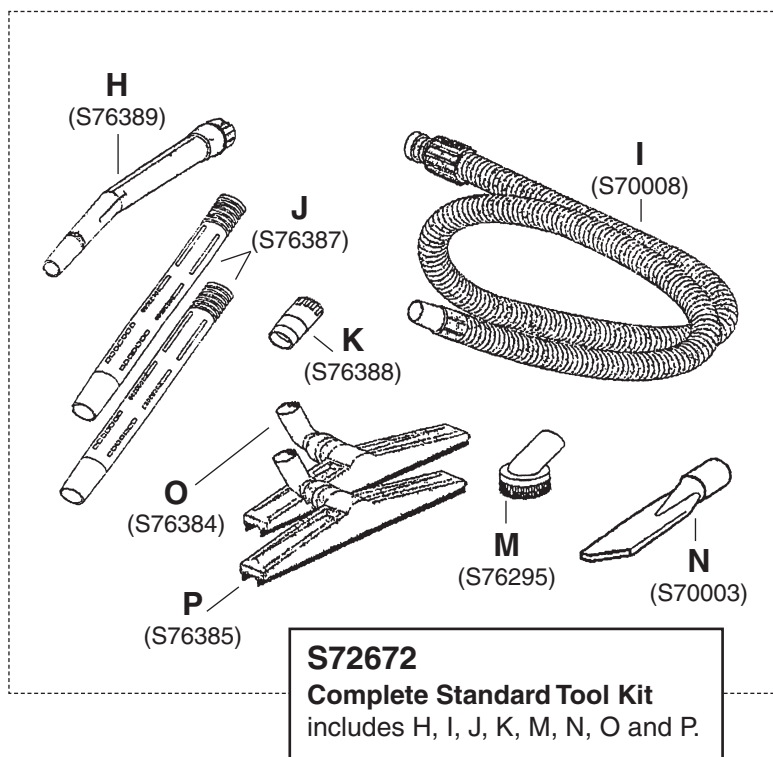

## OPERATION

This machine is a commercial vacuum designed for wet and dry pick-up. The dual vac motors can be run together or separately as the job requires.

Dry soil can be vacuumed directly into the tank. To empty the tank of dry soil, remove the top and dump into trash receptacle.

For wet pick-up, remove polyester filter. The machine is equipped with a float shut-off. As the tank is filled to capacity, a float rises and seals the vac intake, causing loss of vacuum. Switch off the vacuum when this happens and bring the machine to a floor drain.

Use the convenient drain hose at the back of the vacuum to empty the tank.

With both wet and dry applications be sure to frequently clean the filter. This is especially true when the vacuum is being used with strippers and wax.

## DAILY MAINTENANCE

**Caution: Strippers and some detergents produce foam which will damage the vac motors. The vac shut-off may not be sensitive to all foams. Be sure to check that the tank is not filling with foam. Use a defoaming agent to avoid pulling foam through vac motor. Should vac motor become wet, remove source of overflow and immediately run vac motor open to dry.**

### *At the end of each working day:*

1. After each use, rinse tank with fresh water. Periodically inspect the recovery tank and decontaminate if necessary, using a Hospital Grade Virucide or a 1:10 bleach to water solution. Waste water should be disposed of properly.
2. Remove head assembly and allow tank to dry.
3. Remove filters for cleaning or to allow to dry.
4. Inspect hoses for wear. Frayed or cracked hoses should be replaced to avoid vacuum loss.
5. Inspect power cord for wear. This cable will lay on wet surfaces. To prevent electrical shock replace cords with frayed or cracked insulation immediately.

## DUAL SWITCHES

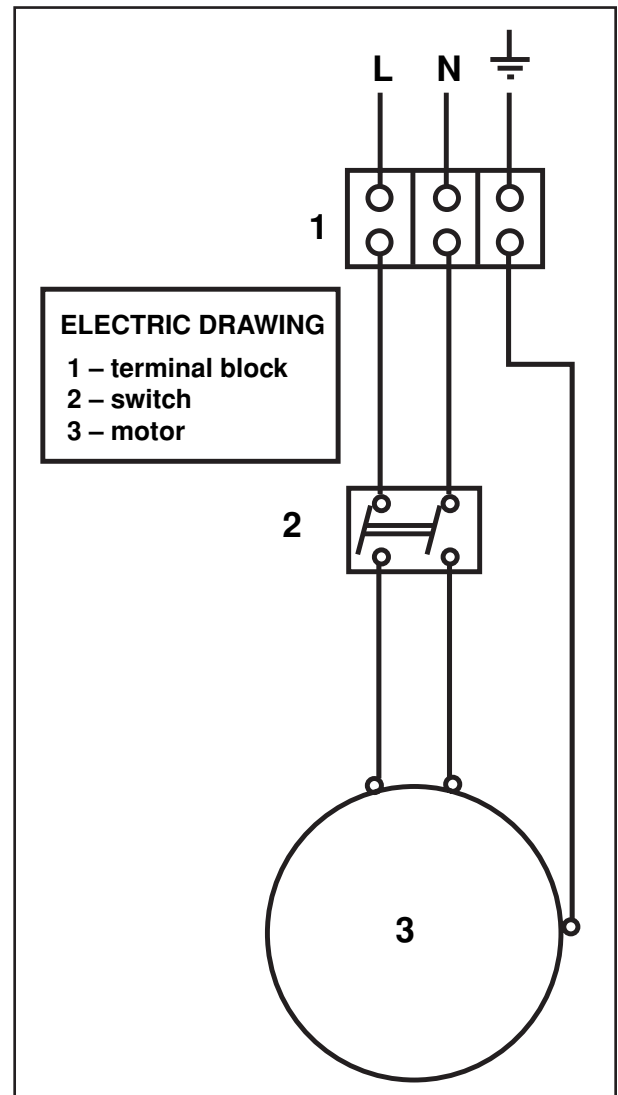
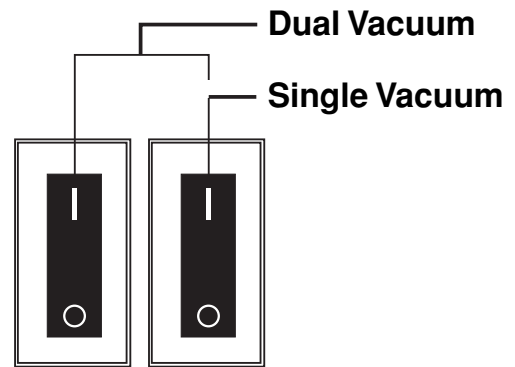

## PERIODIC MAINTENANCE

### *(Every six to twelve months):*

1. Check filter for wear, replace dirt saturated filters that do not respond to normal cleaning.
2. Inspect gasket seals and replace those which have begun to leak.
3. Examine carbon motor brushes and commutator.

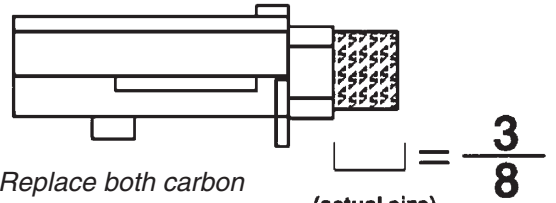

Replace both carbon brushes when either is less than  $\frac{3}{8}$ " long. (PN S8TOEG845)

## SERVICING THE FILTER

The filter is accessed by lifting the head assembly off the tank.

Polyester filter is easily removed by simply lifting the filter basket out of the tank.

Cartridge filters – Remove the filter retainer by turning the black knob 90 degrees counter-clockwise. Cartridge filter will then slide off of float assembly.

### **NOTE:**

Be sure to frequently clean the filter.

Allow filter to dry after being used for wet pick-up.

Filters used for wet pick-up including stripper must be thoroughly cleaned before being allowed to dry.

Worn filters can affect vacuum performance. Replace the filter when it becomes worn out and normal cleaning will not restore vac performance.

## SERVICING THE VAC MOTOR

### **MOTOR REPLACEMENT**

1. Disconnect power cord from power source.
2. To access the vac motor, remove the screws that attach the main cover to the head assembly and set the cover to one side.
3. Disconnect the motor's 2 red lead wires from the main switch.
4. Disconnect green/yellow wire by removing screw from motor core.
5. Remove the four motor mounting screws.
6. Remove motor plate and set aside.
7. Take out the motor and remove the upper and lower gaskets.
8. Inspect gaskets. If they shown any wear or tear in the material, replace.
9. Install gaskets onto new motor. Make sure gaskets are properly seated.
10. Install the new motor. Make sure foam mufflers are positioned properly.
11. Attach motor plate to motor.
12. Connect green/yellow wire to motor core.
13. Connect motor's 2 red lead wires to main switch.
14. Re-assemble vac cover.
15. Test for proper operation.

## SERVICING THE VAC MOTOR

### CARBON BRUSH REPLACEMENT

1. Disconnect power cord from power source.
2. To access the vac motor, remove the screws that attach the main cover to the head assembly and set the cover to one side.
3. Remove the motor cover by removing two screws. **See Figure 1**
4. Remove the wire terminal from carbon brush housing. **See Figure 2**
5. Remove the carbon brush assembly by removing the 2 screws that attach it to the vac motor. **See Figure 3**
6. Inspect armature commutator. If it is extremely pitted, grooved or not concentric then the motor will need to be replaced or sent to a qualified service center.
7. Slide the yellow brush housing from plastic holder. **See Figure 4**
8. Reverse steps 7 through 4 to install new brush and housing (part number S8TOEG845)
9. Repeat steps 4 through 8 for the other carbon brush.
10. Reverse steps 3 and 2 for re-assembly.
11. Test for proper operation

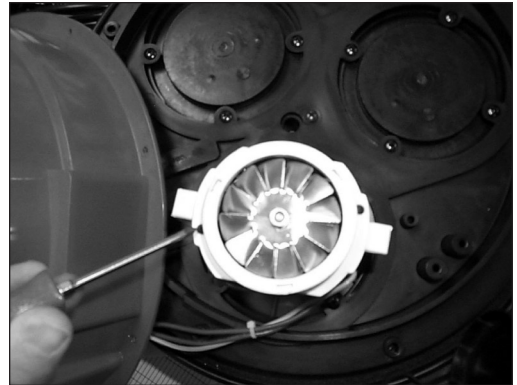

Fig. 1

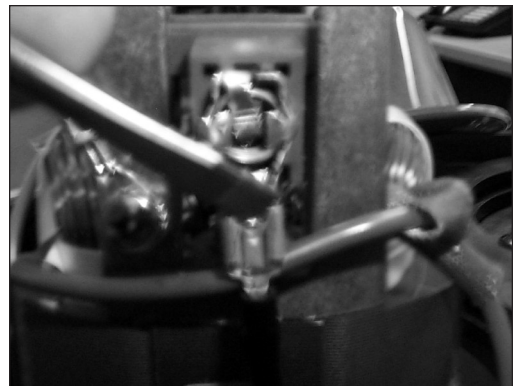

Fig. 2

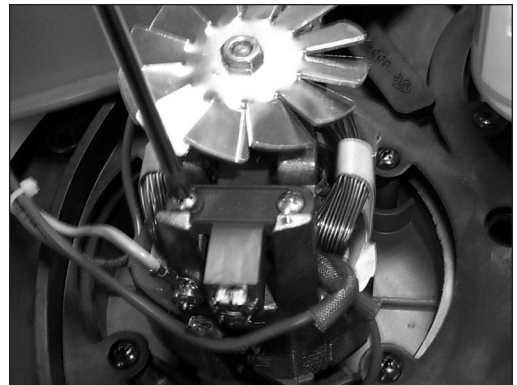

Fig. 3

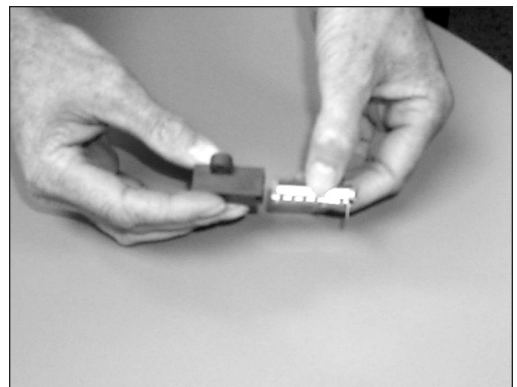
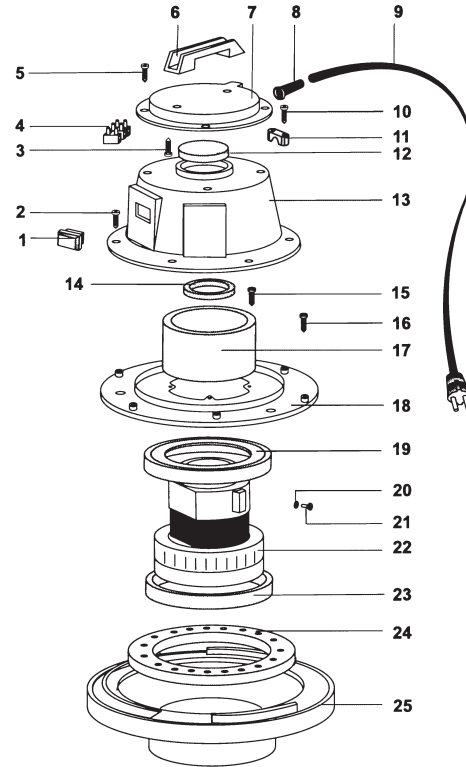

Fig. 4

### 315 VACUUM MOTOR ASSEMBLY

No.	Part Num.	Description	Qty.
1.	S80326	Switch, ON/OFF	1
2.	S81006	Screw, 5 x 20	5
3.	S81006	Screw, 5 x 20	2
4.	S80140	Terminal Block	1
5.	S81006	Screw, 5 x 20	4
6.	S82992	Handle, Lift	1
7.	S81152		1
8.	S80138	Strain Relief, Black	1
9.	S81122	Cord	1
10.	S81006	Screw, 5 x 20	2
11.	S80139	Clamp, Cord	1
12.	S83937	Filter	
13.	S81146	Cover, Dome	1
14.	S83969	Gasket, Motor Exhaust	1
15.	S81006	Screw, 5 x 20	4
16.	S81005	Screw, 5 x 14	2
17.	S83900	Filter	1
18.	S83608AU	Motor Support	1
19.	S83901	Motor Gasket	1
20.	S81024	Washer, M4	1
21.	S81064	Screw, M4 x 8	1
22.	S81120S	Motor, 1000W, 120V/60Hz	1
23.	S83901	Motor Gasket	1
24.	S83866	Disk, Noise Reduction	1
25.	S80120	Base, Black, with Gasket	1



### 315 FILTER GROUP

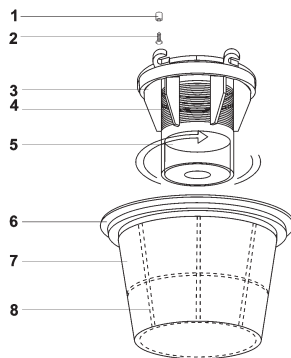

No.	Part Num.	Description	Qty.
1.	S83706	Bushing, Ø8	4
2.	S83724	Screw, 5 x 25	4
3.	S82823	Body, Float	1
4.	S83138	Filter, Strainer	1
5.	S82676	Float	1
6.	S80123	Ring, Filter	1
7.	S82860	Filter Bag	1
8.	S82859	Support, Filter Bag	1

### 315 TANK ASSEMBLY

No.	Part Num.	Description	Qty.
	S82221	Complete Tank	1
1.	S82028	Tank	1
2.	S81302	Rivet, 5 x 19	4
3.	S81847	Clamp	2
4.	S81026	Screw, 5 x 30	4
5.	S82846	Gasket	1
6.	S82585	Retainer	1
7.	S82608	Spring	1
8.	S82593	Deflector	1
9.	S82594	Push Button	1
10.	S82583	Hose Adapter	1
11.	S82008	Caster	4
12.	S82680	Screw, M4 x 15	16

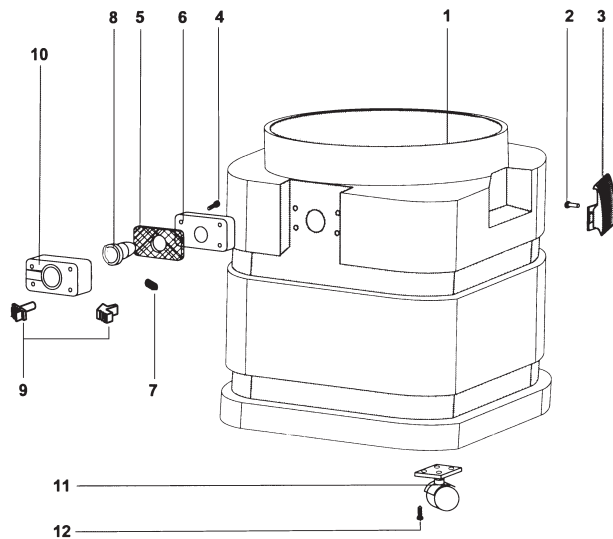

## 415 VACUUM MOTOR ASSEMBLY

No.	Part Num.	Description	Qty.
1.	S81006	Screw, 5 x 20	6
2.	S81150	Cover, Dome	1
3.	S82992	Handle	1
4.	S81006	Screw, 5 x 20	2
5.	S80139	Clamp, Cord	1
6.	S80138	Strain Relief	1
7.	S81122	Power Cord, Single Motor	1
	T82102005	Power Cord, Dual Motor	
8.	S81006	Screw, 5 x 20	2
9.	S81005	Screw, 5 x 14	2
10.	S80508	Terminal Block	1
11.	S83383	Cap	2
12.	S81050	Screw, 5 x 35	7
13.	S81130	Cover, Single Motor	1
	S81135	Cover, Dual Motor	
14.	S80326	Switch, On/Off	1
15.	S81026	Screw, 5 x 30	1
16.	S81006	Screw, 5 x 20	4
17.	S81006	Screw, 5 x 20	8
18.	S80464AU	Motor Base	1
19.	S83969	Gasket	3
20.	S83901	Gasket	1
21.	S81024	Washer, M4	1
22.	S81064	Screw, M4 x 8	1
23.	S81120S	Motor, 1000W, 120V/60Hz	1
24.	S83901	Gasket	1
25.	S83901	Gasket	2
26.	S83451	Plug	2
27.	S83454	Filter	3
28.	S83456	Filter	3
29.	S83519	Cap	2
30.	S80488	Base with Gasket	1

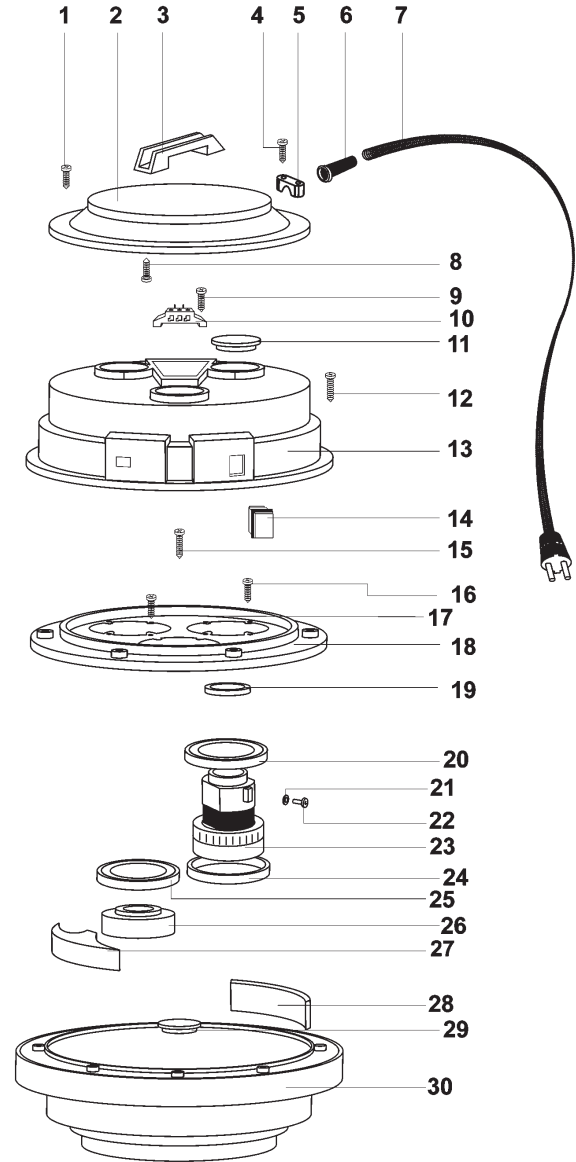

## 415 FILTER GROUP

No.	Part Num.	Description	Qty.
1.	S83706	Bushing	4
2.	S83724	Screw, 5x25	4
3.	S82823	Body, Filter Support	1
4.	S83117	Strainer	1
5.	S82676	Float	1
6.	S80473	Filter Ring	1
7.	S82845	Filter Bag	1
8.	S82833	Support, Filter	1
9.	S82852	Filter – OPTIONAL	1
10.	S82855	Filter Retainer – OPTIONAL	1

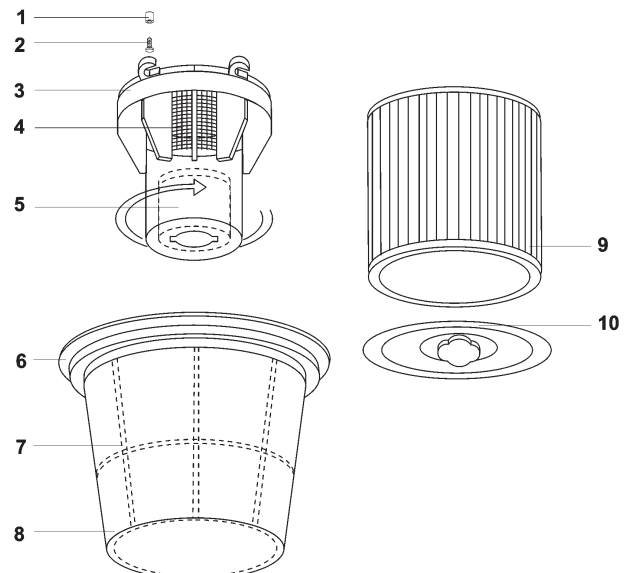

# 415P TANK ASSEMBLY

No.	Part Num.	Description	Qty.	No.	Part Num.	Description	Qty.
	S82615	Complete Tank	2	18.	S80904	Wheel, Ø200	2
1.	S82558	Handle	1	19.	S82557	Cap, End	2
2.	S82637	Tank	1	20.	S83835	Cap, Axle	2
3.	S81026	Screw, 5x30	4	21.	S82607	Spacer, Wheel	2
4.	S82584	Retainer, Tank	1	22.	S81006	Screw, 5 x 20	8
5.	S82846	Gasket	1	23.	S82555	Axle	1
6.	S82593	Deflector	1	24.	S80834	Nut, Flange	1
7.	S82652A	Adapter, Hose	1	25.	S80256	Gasket	1
8.	S81300	Rivet, 5 x 24.5	4	26.	S82763	Elbow	1
9.	S81847	Clamp, Tank	2	27.	S83308	Clamp	1
10.	S81050	Screw, 5 x 35	8	28.	S82765	Drain Tube	1
11.	S83883	Plastic Washer	8	29.	S83156	Screw, 5 x 20	1
12.	S81072	Support, Handle	2	30.	S82788	Clip Tube	1
13.	S81860	Support, Handle	2	31.	S82812	Strap, Plug	1
14.	S81302	Rivet, 5 x 19	2	32.	S82764	Plug, Hose	1
15.	S82559	Caster	2	33.	S86250	Handgrip	2
16.	S82680	Screw, 4 x 15	8	34.	S82594	Push Button, Two-Piece, Red	1
17.	S82556	Support, Axle	2				

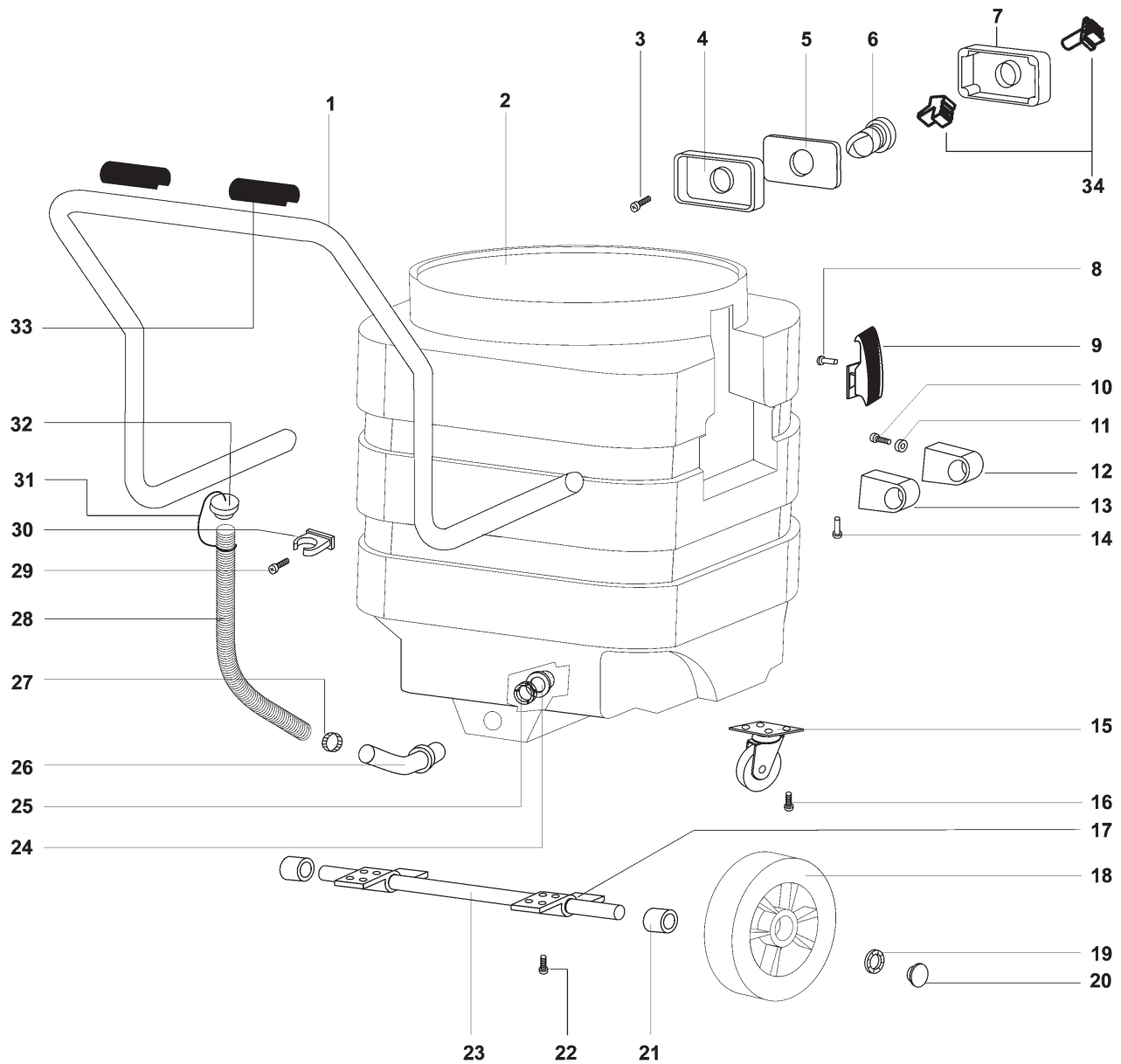

## 415ST TANK ASSEMBLY

No.	Part Num.	Description	Qty.
1.	S82993	Handle	2
2.	S81847	Clamp, Tank	2
3.	S81302	Rivet, 5 x 19	4
4.	S83629	Screw, 5 x 25	4
5.	S83883	Washer	4
6.	S83253	Tank – Steel	1
7.	S81026	Screw, 5 x 30	4
8.	S82586	Adapter, Tank	1
9.	S82846	Gasket	1
10.	S82593	Deflector	1
11.	S82583	Adapter, Hose	1
12.	S82594	Button	1

No.	Part Num.	Description	Qty.
13.	S82608	Spring	1
14.	S82993	Handle	1
15.	S82974	Washer	2
16.	S83629	Screw, 5 x 25	2
17.	S83156	Screw, 5 x 25	4
18.	S83883	Washer	4
19.	S82968	Hook, Tank	1
20.	S82970	Swivel	2
21.	S82969	Knob, Release	2

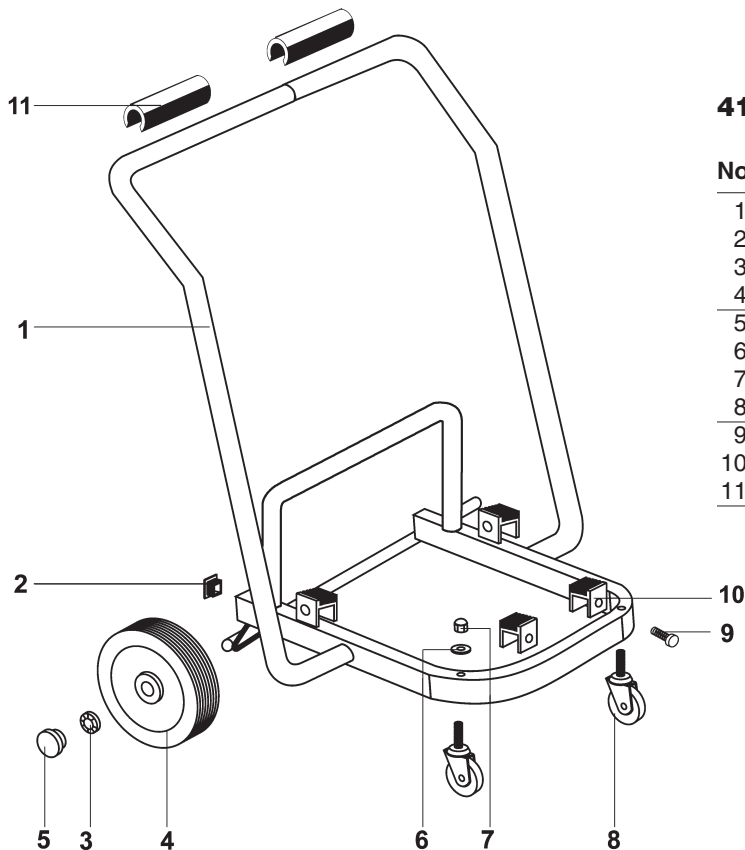
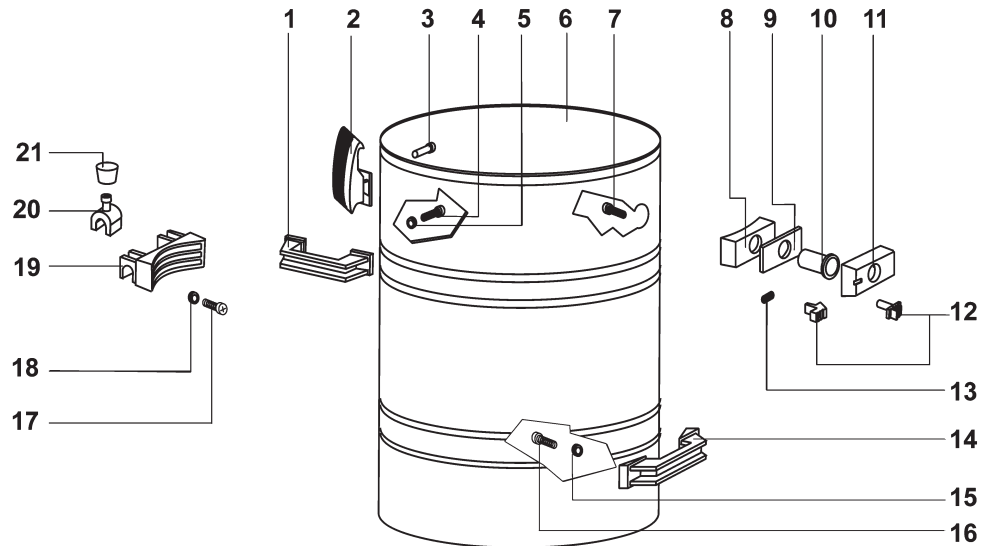

## 415ST CART

No.	Part Num.	Description	Qty.
1.	S83250	Cart	1
2.	S80976	Plug	2
3.	S82557	Cap, End	2
4.	S80904	Wheel	2
5.	S83835	Cap	2
6.	S81012	Washer	2
7.	S80478	Nut	2
8.	S80479	Wheel, Front	2
9.	S81979	Screw, 5 x 25	4
10.	S83450	Clip Pad	4
11.	S86250	Hand Grip	2

## 415S TANK ASSEMBLY

No.	Part Num.	Description	Qty.
1.	S82993	Handle	2
2.	S81847	Clamp, Tank	2
3.	S81302	Rivet, 5 x 19	4
4.	S83629	Screw, 5 x 25	4
5.	S83883	Washer	4
6.	S80476	Tank	1
7.	S81026	Screw, 5 x 30	4
8.	S82586	Adapter, Tank	1
9.	S82846	Gasket	1
10.	S82593	Deflector	1
11.	S82583	Adapter, Hose	1
12.	S82594	Button	1
13.	S82608	Spring	1

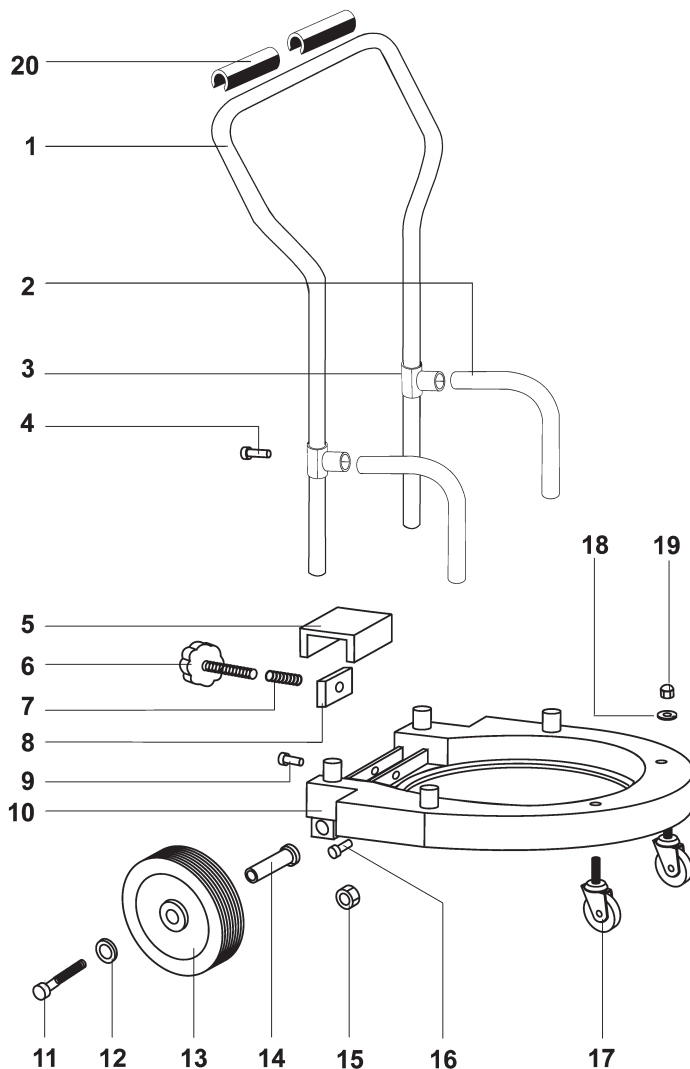
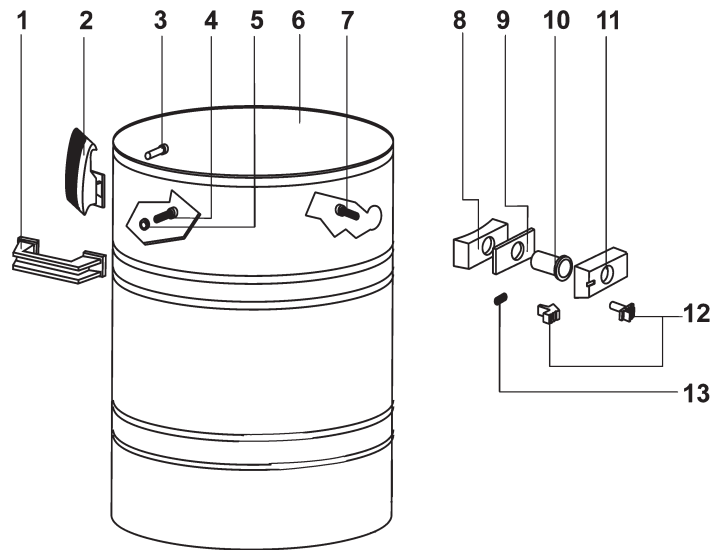

## 415S CART

No.	Part Num.	Description	Qty.
1.	S80918	Handle, Cart	1
2.	S80917	Support, Handle	2
3.	S80913	T-tube	2
4.	S81301	Rivet, 5 x 11	2
5.	S80902	Block	1
6.	S80914	Hand Wheel, M8 x 60	1
7.	S81402	Spring	1
8.	S81403	Plate, Threaded	1
9.	S81301	Rivet, 5 x 11	2
10.	S80901	Base, Cart	1
11.	S80915	Screw, 12 x 140	2
12.	S81028	Washer, M12	2
13.	S80904	Wheel	2
14.	S81401	Bushing	2
15.	S82052	Spacer	2
16.	S81301	Rivet, 5 x 11	2
17.	S80479	Wheel	2
18.	S81012	Washer	6
19.	S80478	Nut, M10	2
20.	S86250	Hand Grip	2

## 415PLT TANK ASSEMBLY

No.	Part Num.	Description	Qty.
1.	S81847	Clamp, Tank	2
2.	S81300	Rivet, 5 x 24.5	4
3.	S83773	Tank	1
4.	S81026	Screw, 5 x 30	4
5.	S82586	Adapter, Tank	1
6.	S82846	Gasket	1
7.	S82593	Deflector, Tank	1
8.	S82583	Adapter, Hose	1
9.	S82594	Button, Hose	1
10.	S82608	Spring	1
11.	S83771	Bumper	1
12.	S82993	Handle	1

No.	Part Num.	Description	Qty.
13.	S83883	Washer, Plastic	2
14.	S81026	Screw, 5 x 30	2
15.	S81026	Screw, 5 x 30	4
16.	S83883	Washer, Plastic	4
17.	S82172	Hook, Tank	1

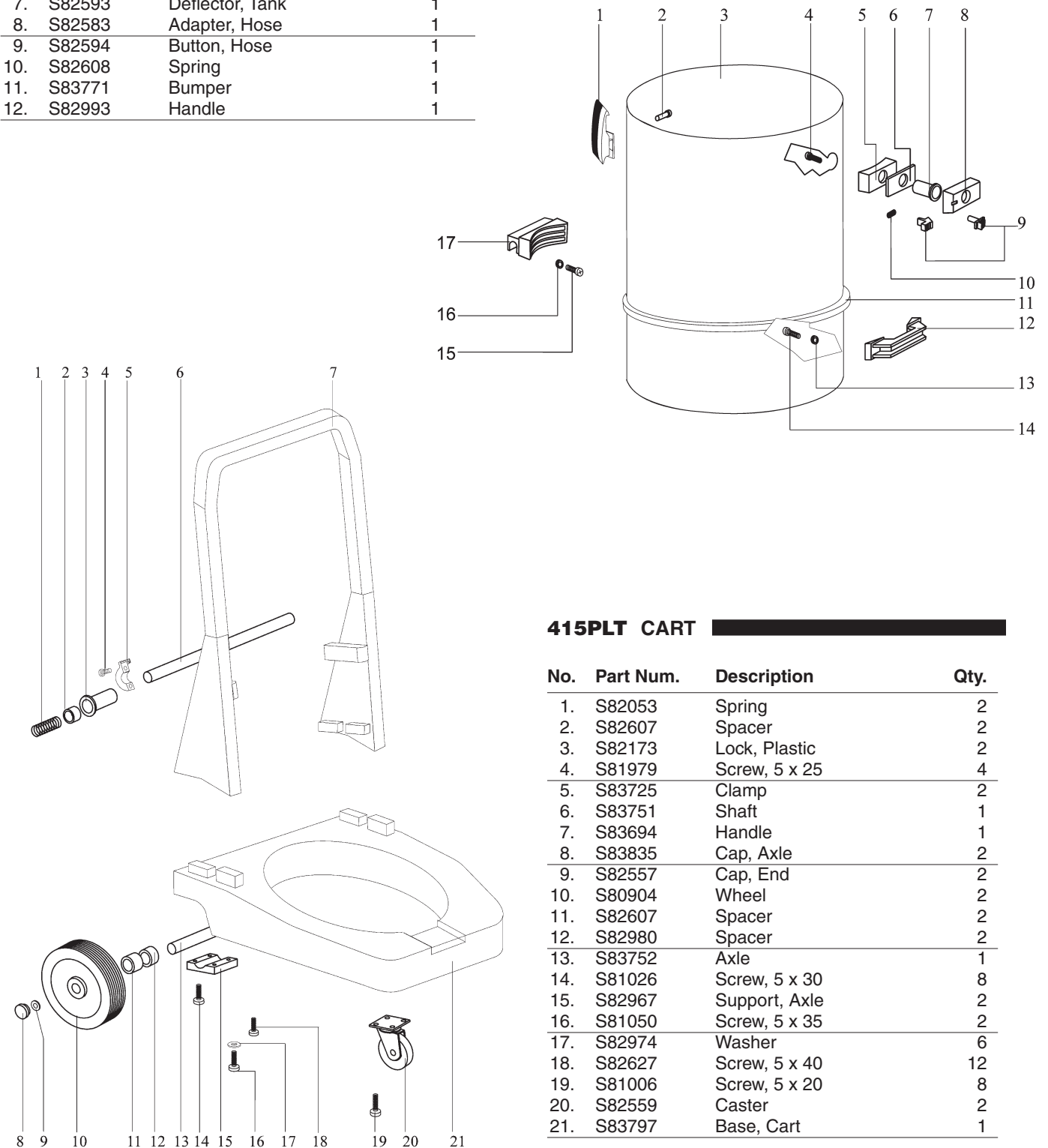

## 415PLT CART

No.	Part Num.	Description	Qty.
1.	S82053	Spring	2
2.	S82607	Spacer	2
3.	S82173	Lock, Plastic	2
4.	S81979	Screw, 5 x 25	4
5.	S83725	Clamp	2
6.	S83751	Shaft	1
7.	S83694	Handle	1
8.	S83835	Cap, Axle	2
9.	S82557	Cap, End	2
10.	S80904	Wheel	2
11.	S82607	Spacer	2
12.	S82980	Spacer	2
13.	S83752	Axle	1
14.	S81026	Screw, 5 x 30	8
15.	S82967	Support, Axle	2
16.	S81050	Screw, 5 x 35	2
17.	S82974	Washer	6
18.	S82627	Screw, 5 x 40	12
19.	S81006	Screw, 5 x 20	8
20.	S82559	Caster	2
21.	S83797	Base, Cart	1

## S70042 FRONT-MOUNTED SQUEEGEE

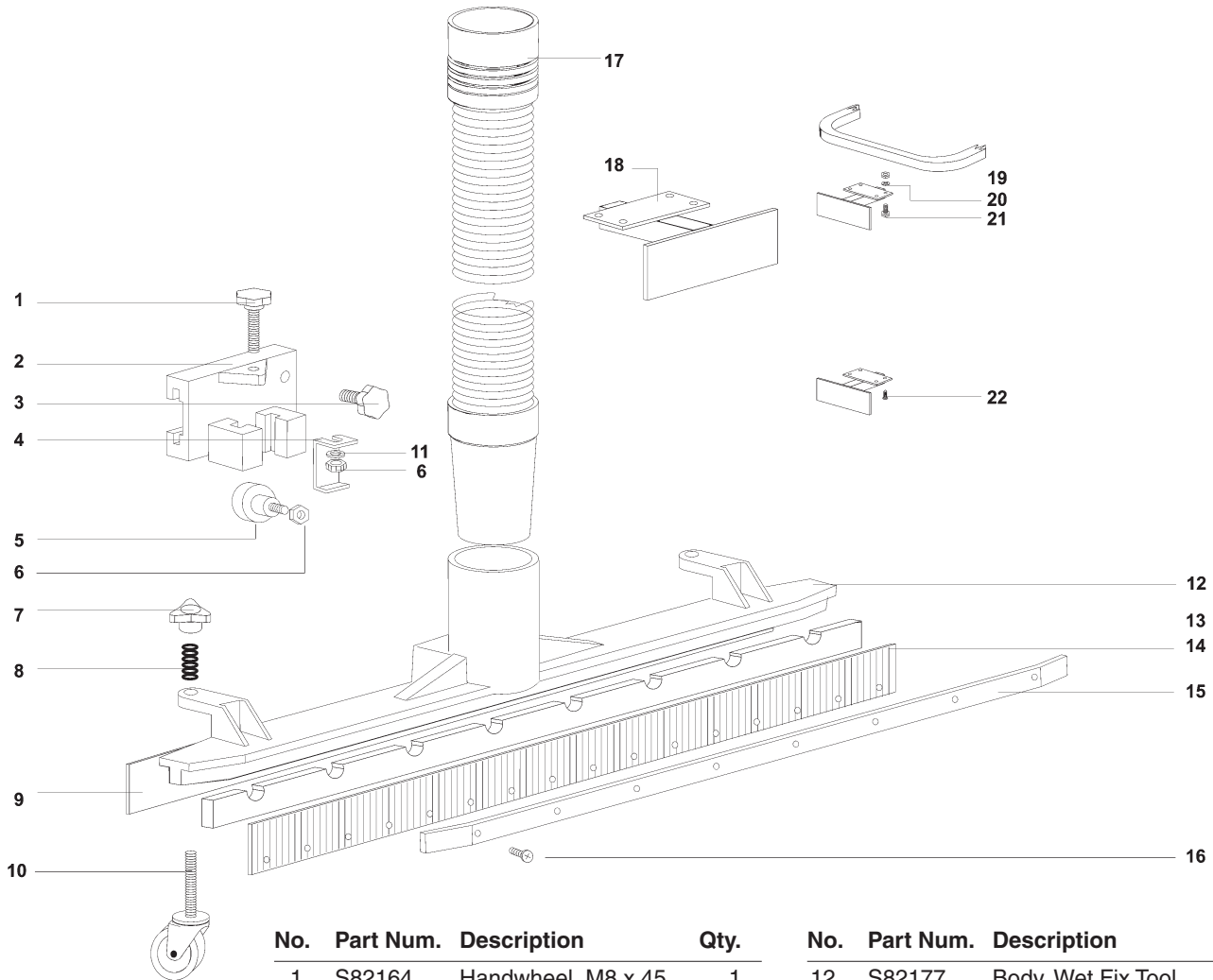

No.	Part Num.	Description	Qty.	No.	Part Num.	Description	Qty.
1.	S82164	Handwheel, M8 x 45	1	12.	S82177	Body, Wet Fix Tool	1
2.	S82187	Small Block, Fixed	1	13.	S82198	Spacer	2
3.	S82163	Handwheel, M6 x 25	1	14.	S82196	Front Squeegee	1
4.	S83115	Plate, Adjustment	1	15.	S82197	Bracket, Squeegee	2
5.	S82189	Driver Pivot	1	16.	S81856	Screw, M4 x16	16
6.	S81033	Nut, M8	2	17.	S80010	Hose, Wet Fix Tool	1
7.	S81732	Adjustment Knob	2	18.	S82297	Mounting Bracket	1
8.	S86137	Spring, Ø40	2	19.	S81035	Nut, M5	4
9.	S82245	Rear Squeegee	1	20.	S81036	Washer, M5	4
10.	S86138	Wheel, AIF, Ø40	2	21.	S81755	Screw, M5 x 16	4
11.	S81034	Washer, Plain, M8	1	22.	S81006	Screw, M5 x 20	4

## ACCESSORIES

- S70042 Front Mounted Squeegee, for all 415 models
- S72741 Paper Bag
- S82860 Filter Bag, Standard for 315 model
- S82845 Filter Bag, Standard for 415 model
- S82852\* Filter Cartridge, Paper, Optional for 415
- S76061\* Filter Cartridge, Washable Paper, Optional for 415
- S82995\* Filter Cartridge, HEPA Equivalent, Optional for 415
- S82881\* Filter Cartridge, HEPA Equivalent, Optional for 315
- S82855 Cartridge Filter Retainer, for all models

\*also order S82855 Retainer with Filter

## RECOMMENDED SPARE PARTS

- S8TOEG845 . . . . . Motor Brush
- S80326 . . . . . Switch, On/Off
- S82860 . . . . . Polyester Filter, 315
- S82845 . . . . . Polyester Filter, 415
- S83117 . . . . . Strainer



## Warranty Policy

### Limited Warranty

Eagle Power Products (EPP) warrants new cleaning equipment against defects in material and workmanship under normal use and service to the original purchaser as detailed below.

### 10 Years

Subject to the conditions stated below, EPP warrants polyethylene tanks and housings to be free from defects in materials and workmanship for a period of ten years.

### 3 Years

Subject to the conditions stated below, EPP warrants all automatic scrubber components to be free from defects in materials and workmanship for a 3-year period. Parts replaced or repaired are warranted for the remainder of the original warranty period.

### 1 Year

Subject to the conditions stated below, EPP warrants all other cleaning equipment components to be free from defects in materials and workmanship for a 1-year period. Parts replaced or repaired are warranted for the remainder of the original warranty period. Batteries are prorated for one year.

EPP will furnish and charge for replacement parts, including transportation, to the original owner through an EPP authorized service center. If the part is returned within 30 days and is found defective, the owner will be credited for the cost of the replacement part including shipping and handling.

Labor charges are covered for one year from the date of purchase if provided by an authorized EPP service center. Travel is covered for 90 days for battery operated equipment only.

Wear items exempt from warranty include belts, carbon brushes, power cords, wheels, pad drivers, clutch plates, brushes, pads, handle grips, filters, screens, throttle cables, and squeegees.

This warranty shall not apply to failures caused by misuse or abuse, improper maintenance as stated in the operation manuals, use of unauthorized repair parts, repairs by other than an EPP authorized service center, and damage in transit.

EPP disclaims and denies any liability for any direct, indirect, special incidental or consequential damage which may be suffered as a result of sale, delivery, servicing, use, loss of any product, downtime, labor, freight, or other charges not expressly included herein.

Date Purchased: \_\_\_\_\_

Model Number: \_\_\_\_\_

Serial Number: \_\_\_\_\_

Please be sure to record this information. This information will be necessary for future warranty reclaims.



1174 Northland Drive Mendota Heights, MN 55120  
651.686.5399 Fax 651.686.5695  
www.eaglepower.com

*Eagle Power Products Sales and Service Provided by:*