



## Electronic Service Manuals

This electronic document is provided as a service to our customers. We do not create the contents of the information contained in this document. Should you have detailed questions pertaining to the information contained in this document, you may contact Michco, or the manufacturer which provided the original information in this electronic deliverable. Michco's only part in this electronic deliverable was the electronic assembly process. By providing this manual on line we are not guaranteeing parts availability.

You may contact Michco through the following methods:

Phone (517) 484-9312 or (800) 331-3339

2011 N. High St. -- Lansing, Michigan -- 48906

Fax: (517) 484-9836

Email: [CustServe@Michco.com](mailto:CustServe@Michco.com)

Web site: [www.Michco.Com](http://www.Michco.Com)

Parts Web site: [www.FloorMachineParts.Com](http://www.FloorMachineParts.Com)

Order Parts on Line at:

**[www.FloorMachineParts.Com](http://www.FloorMachineParts.Com)**

Directly to Parts & Service:

By Email: **[Shop@Michco.com](mailto:Shop@Michco.com)**

By Fax: (517) 702-2041

By Voice: Use numbers above.

**Serving the Cleaning Industry Since 1922**

Notice: All copyrighted material remains property of original owners, all trademarks are property of respective owners. Manuals are subject to Manufacturer's reproduction limitations. Originals or reproductions were provided by manufacturers through a request. We make no warranty as to the correctness of information provided in this document and you assume all risk. By placing these manuals on line we are not declaring our corporation to be an manufacturer authorized dealer or provider, please check our web site for authorized manufacturers we represent.

# **Eagle Power™**

## **Products Group**



**TK500M  
MANUAL  
SWEEPER**

**ENTER** 

**PARTS MANUAL**



Click on icon to  
return to this page.

← Back 1 page

# TK500M MANUAL SWEEPER

*Broom Assembly*

*Broom Adjustment Assembly*

*Side Broom Assembly*

*Hopper Assembly*

*Wheel Assembly*



← Back 1 page

### TK 500M SWEEPER - Broom Assembly

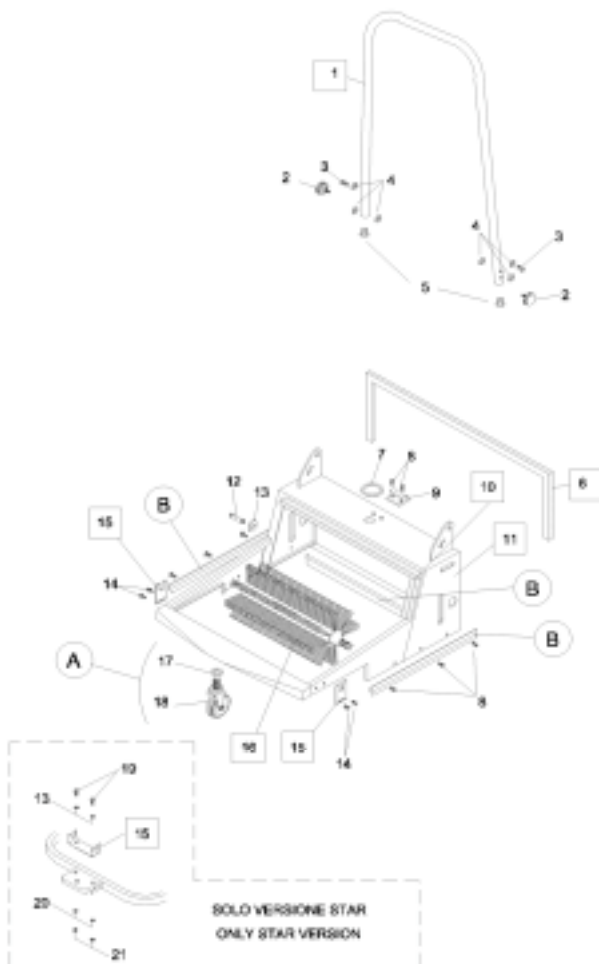

### TK 500M SWEEPER - Broom Assembly

POSITION	PART NUMBER	DESCRIPTION
1	***	TKM handle Black
2	1320030	Handwheel Ø 40 M 8x15
3	1105181	Screw 8x16
4	1105304	Washer 8x17
5	1320036	Rubber
6	***	Backside mousse kit
7	6911003	Label
8	1105356	Self tapping screw 3,5x9,5
9	1320007	Lever lock stricker
10	***	Frontside mousse kit
11	***	Frame
12	2230005	Belt support pin
13	1105325	Washer 6x24

Next page →



← Back 1 page

<b>TK 500M SWEEPER - Broom Assembly</b>		
<b>POSITION</b>	<b>PART NUMBER</b>	<b>DESCRIPTION</b>
14	1105361	Self tapping screw 6.3x19
15	***	Front hopper support' stand
16	***	Main brush
17	1105306	Washer 6X18
18	2250024	Front wheel Ø80 x 25
19	1105162	Screw 6x16
20	1105324	Washer 6X18
21	1105123	Nut M6
B	***	Frame's flap Kit
A )		2 pcs for the model - STAR 85
		- DELTA 85 - NEW 503 *** See code table

Next page →



← Back 1 page

**TK 500M SWEEPER - Broom Adjustment Assembly**

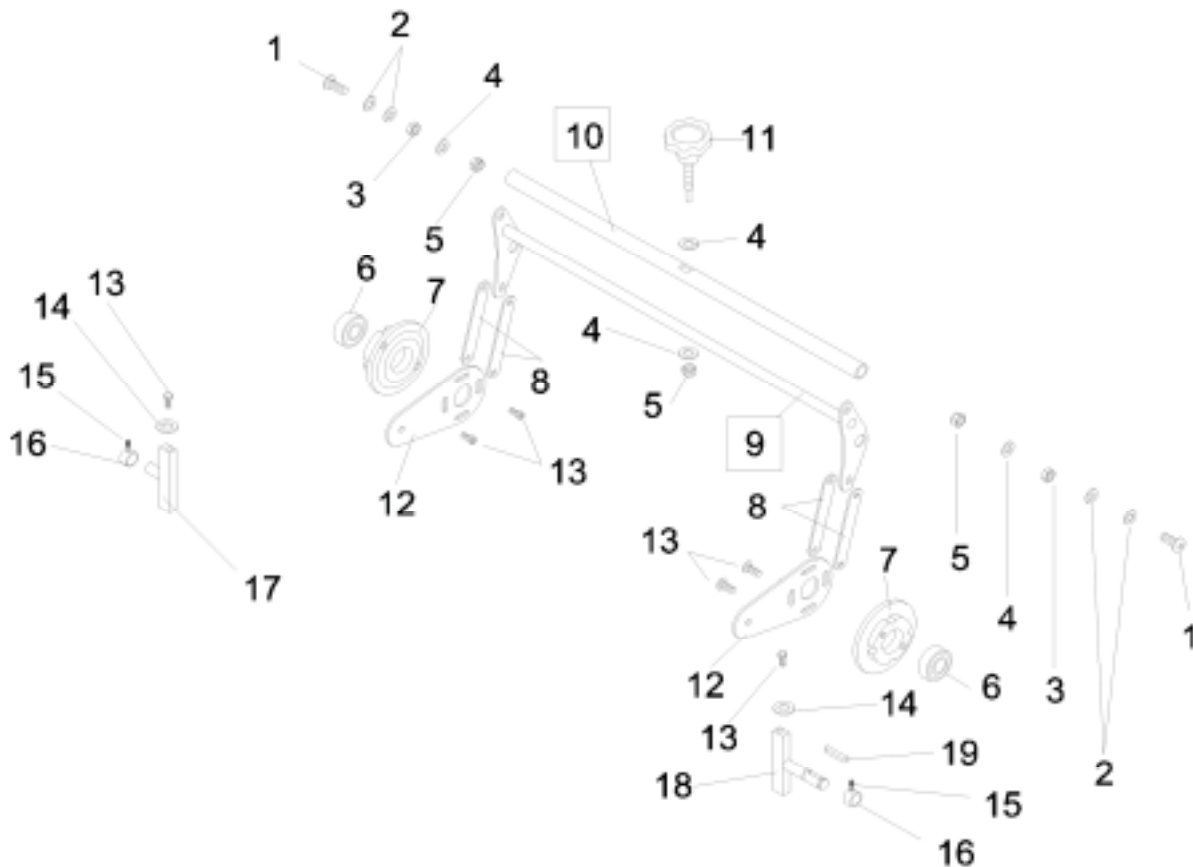

**TK 500M SWEEPER - Broom Adjustment Assembly**

POSITION	PART NUMBER	DESCRIPTION
1	1105066	Screw 8x35
2	1105326	Washer 8x24
3	1105124	Nut M8
4	1105304	Washer 8x17
5	1105134	Locknut M8
6	1390009	Bearing 6202 2RS
7	2260007	Bearing support
8	2190003	Rocker's bracket
9	2110015	Rocker 45
9	2110012	Rocker 65
9	2110006	Rocker 85
10	2110020	Rocker's pipe 45
10	2110013	Rocker's pipe 65
10	2110004	Rocker's pipe 85
11	1320031	Handwheel Ø60 M 12x67
12	2260008	Rocker's bushing' support bracket

Next page →



← Back 1 page

**TK 500M SWEEPER - Broom Adjustment Assembly**

<b>POSITION</b>	<b>PART NUMBER</b>	<b>DESCRIPTION</b>
13	1105160	Screw 6x10
14	1105324	Washer 6x18
15	1105482	Dowel 6x6
16	2130003	Spacer
17	2100011	Brush' shaft
18	2100001	Brush driving shaft
19	1105461	Key 3x3x15

Next page →



Back 1 page

**TK 500M SWEEPER - Side Broom Assembly**

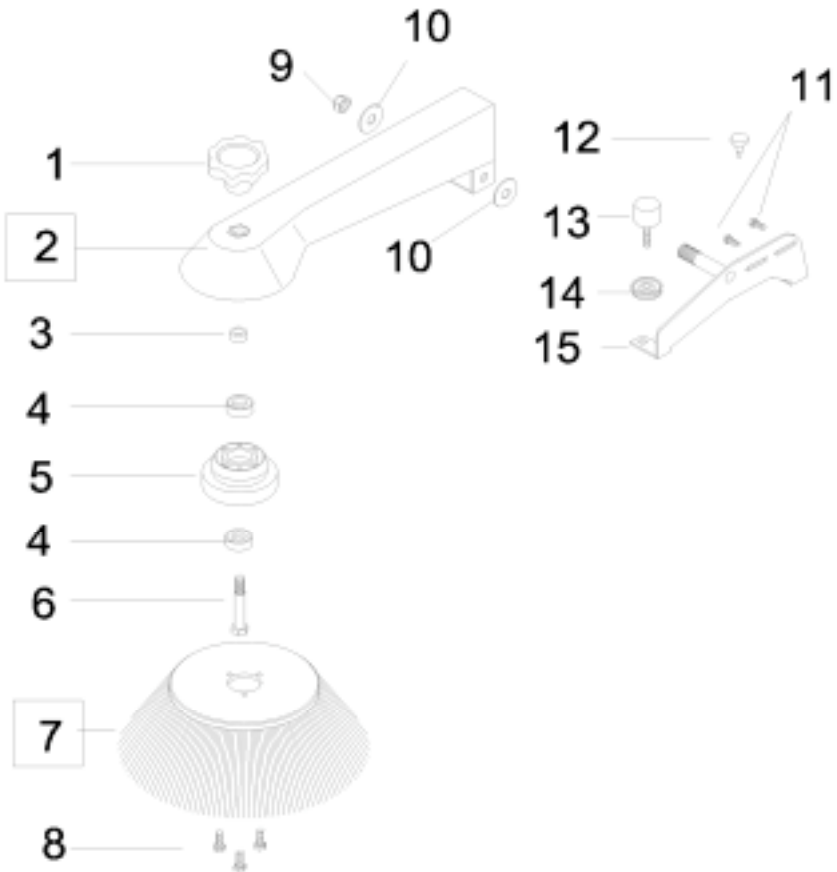

**TK 500M SWEEPER - Side Broom Assembly**

POSITION	PART NUMBER	DESCRIPTION
1	1320008	Handwheel Ø60M 10
2	2260038	Blue side arm
2	2260014	Black side arm
3	2130008	Arm' spacer
4	1390008	Bearing 6201 2RS
5	1250010	Pulley Ø 82
6	2290003	Side arm's pivot
7	1350002	Side brush PPL 50
7	1350011	Side brush PPL 70
8	1105160	Screw 6x10
9	1105135	Block nut M 10
10	1105305	Washer 10x21
11	1105181	Screw 8x16
12	2370001	Antivibrations
13	1270003	Plug
14	1110007	Knurled ring nut, Ø40 M8
15	2260011	Side arm's support

Next page



Back 1 page

**TK 500M SWEEPER - Hopper Assembly**

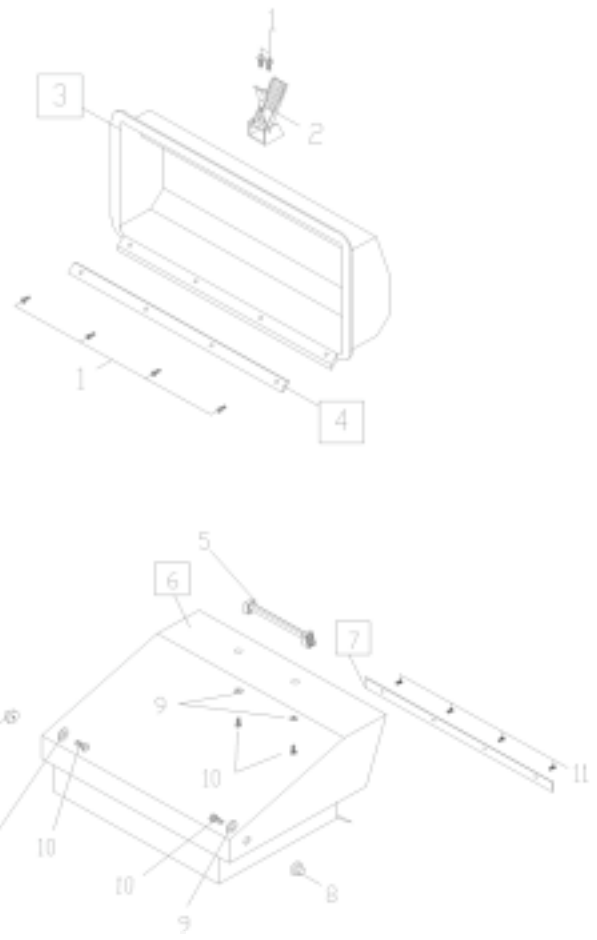

**TK 500M SWEEPER - Hopper Assembly**

POSITION	PART NUMBER	DESCRIPTION
1	2160012	Back hopper's rubber
2	1105001	Screw 4x12
3	2150005	Back hopper's rubber stop
4	1105121	Nut M4
5	2120059	White rear hopper
5	2120063	Yellow rear hopper
5	2120268	Blue rear hopper
5	2120017	Red rear hopper
5	2120065	Green rear hopper
6	1320002	Lever lock
7	1105356	Self tapping screw 3,5x9,5
8	2260022	Front hopper's support
9	1105305	Washer 10x21
10	1105181	Screw 8x16

Next page



← Back 1 page

<b>TK 500M SWEEPER - Hopper Assembly</b>		
<b>POSITION</b>	<b>PART NUMBER</b>	<b>DESCRIPTION</b>
11	2120058	White front hopper
11	2120062	Yellow front hopper
11	2120267	Blue front hopper
11	2120016	Red front hopper
11	2120064	Green front hopper
12	1105121	Nut M4
13	2160013	Front hopper's rubber
14	2150006	Rubber retainer for the front drawer
15	1105001	Screw 4x12

Next page →

**TK 500M SWEEPER - Wheel Assembly**

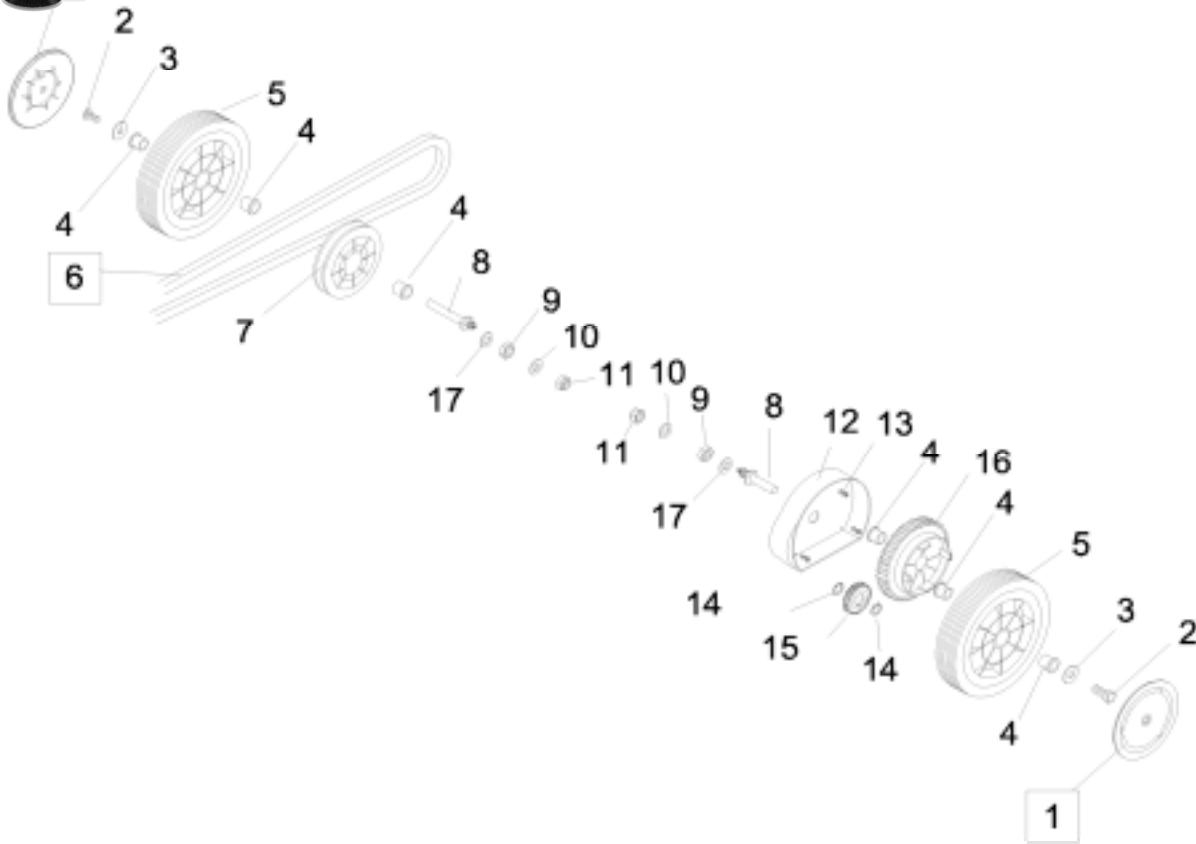

**TK 500M SWEEPER - Wheel Assembly**

POSITION	PART NUMBER	DESCRIPTION
1	2120071	Blue wheel's cover Ø 250
1	2120070	Yellow wheel's cover Ø 250
1	2120072	White wheel's cover Ø 250
1	2120081	Black wheel's cover Ø 250
1	2120013	Red wheel's cover Ø 250
2	1105160	Screw 6x10
3	1105325	Washer 6x24
4	2110008	Bushing, Ø20 x15
5	1250020	Ø 250 Wheel
6	1330005	Belt Z 60
6	1330004	Belt Z 64
7	2250026	Pulley Ø 178M
8	2230008	Manuals wheel's pivot
9	1105221	Nut M 18
10	1105326	Washer 8x24
11	1105134	Locknut M8
12	2120014	Side casing
13	1105356	Self tapping screw 3,5x9,5
14	1105405	Outer snap ring Ø 15



← Back 1 page

**TK 500M SWEEPER - Wheel Assembly**

<b>POSITION</b>	<b>PART NUMBER</b>	<b>DESCRIPTION</b>
15	2250022	Ø 48 Gear
16	2250023	Ø 138 M Gear
17	1105314	Washer 18x34

Next page →



← Back 1 page

# Eagle Power

## Warranty Policy

### Limited Warranty

**Eagle Power Products (EPP) warrants new cleaning equipment against defects in material and workmanship under normal use and service to the original purchaser as detailed below.**

### 10 Years

**Subject to the conditions stated below, EPP warrants polyethylene tanks and housings to be free from defects in materials and workmanship for a period of ten years.**

### 3 Years

**Subject to the conditions stated below, EPP warrants all automatic scrubber components to be free from defects in materials and workmanship for a 3-year period. Parts replaced or repaired are warranted for the remainder of the original warranty period.**

### 1 Year

**Subject to the conditions stated below, EPP warrants all other cleaning equipment components to be free from defects in materials and workmanship for a 1-year period. Parts replaced or repaired are warranted for the remainder of the original warranty period. Batteries are prorated for one year.**

**EPP will furnish and charge for replacement parts, including transportation, to the original owner through an EPP authorized service center. If the part is returned within 30 days and is found defective, the owner will be credited for the cost of the replacement part including shipping and handling.**

Labor charges are covered for one year from the date of purchase if provided by an authorized EPP service center. Travel is covered for 90 days for battery operated equipment only.

Wear items exempt from warranty include belts, carbon brushes, power cords, wheels, pad drivers, clutch plates, brushes, pads, handle grips, filters, screens, throttle cables, and squeegees.

This warranty shall not apply to failures caused by misuse or abuse, improper maintenance as stated in the operation manuals, use of unauthorized repair parts, repairs by other than an EPP authorized service center, and damage in transit.

EPP disclaims and denies any liability for any direct, indirect, special incidental or consequential damage which may be suffered as a result of sale, delivery, servicing, use, loss of any product, downtime, labor, freight, or other charges not expressly included herein.

Date Purchased: \_\_\_\_\_

Serial Number: \_\_\_\_\_

Model Number: \_\_\_\_\_

Please be sure to record this information. This information will be necessary for future warranty claims.



1174 Northland Drive Mendota Heights, MN 55120  
651.686.5399 Fax 651.686.5695  
www.eaglepower.com

*Eagle Power Products Sales and Service Provided by:*