



## Electronic Service Manuals

This electronic document is provided as a service to our customers. We do not create the contents of the information contained in this document. Should you have detailed questions pertaining to the information contained in this document, you may contact Michco, or the manufacturer which provided the original information in this electronic deliverable. Michco's only part in this electronic deliverable was the electronic assembly process. By providing this manual on line we are not guaranteeing parts availability.

You may contact Michco through the following methods:

Phone (517) 484-9312 or (800) 331-3339

2011 N. High St. -- Lansing, Michigan -- 48906

Fax: (517) 484-9836

Email: [CustServe@Michco.com](mailto:CustServe@Michco.com)

Web site: [www.Michco.Com](http://www.Michco.Com)

Parts Web site: [www.FloorMachineParts.Com](http://www.FloorMachineParts.Com)

Order Parts on Line at:

**[www.FloorMachineParts.Com](http://www.FloorMachineParts.Com)**

Directly to Parts & Service:

By Email: **[Shop@Michco.com](mailto:Shop@Michco.com)**

By Fax: (517) 702-2041

By Voice: Use numbers above.

**Serving the Cleaning Industry Since 1922**

Notice: All copyrighted material remains property of original owners, all trademarks are property of respective owners. Manuals are subject to Manufacturer's reproduction limitations. Originals or reproductions were provided by manufacturers through a request. We make no warranty as to the correctness of information provided in this document and you assume all risk. By placing these manuals on line we are not declaring our corporation to be an manufacturer authorized dealer or provider, please check our web site for authorized manufacturers we represent.

# **Eagle Power™**

## **Products Group**



# **Speed Vac**

**24" Battery  
Vacuum Sweeper**

**OPERATION AND PARTS MANUAL**

## GENERAL NOTES

This guide has been edited for the CONSUMER according to directive CE89/392 and its ensuing amendments.

Carefully read the notes contained in this guide since they provide with important directions regarding the safety of assembling, use and maintenance.

Each machine, in accordance with directive CE89/392 and its ensuing amendments, is identified by a specific plate positioned on the frame and containing the following information:

<b>Eagle Power</b> Products Group 1174 NORTHLAND DRIVE MENDOTA HEIGHTS, MN 55120		COSTRUTTORE MANUFACTURER HERSTELLER FABRICANT	
N° SERIE / SERIAL N° SERIEN / N° DE SERIE			
MODELLO / MODEL TYP / MODELE	<b>FB 24</b>		
ANNO DI FABBR. / MANUFACTURE YEAR BAUJAHR / ANNEE DE FABRICATION		<b>2002</b>	
CARICA BATTERIA / BATTERY CHARGER LADERGEARTE / CHARGEUR	IN 90-240 VAC OUT 13,1VDC 3,5A		
POTENZA - POWER LEISTUNG - PUISSANCE		<b>150</b>	<b>W</b>
TENSIONE LAVORO / VOLTAGE NENN SPANNUNG / TENSION	<b>12 VDC</b>		
PESO / WEIGHT GEWICHT / POIS		<b>Kg</b>	<b>39</b>

- **Manufacturer**
- **Model**
- **Manufacturing year**
- **Serial number**
- **Power supply voltage**
- **Working voltage**
- **Installed power**
- **Weight**

## DESCRIPTION OF CONTROLS



1



2



3



4

- 1 - **Filter-shaker push-button**
- 2 - **Main switch (Main broom)**
- 3 - **Side broom switch**
- 4 - **Centrifugal electric fan switch**

## CONDITION OF USE

### CONSENTED USES

The 24" Battery Vacuum Sweeper is built for cleaning the ground in the following conditions of employment:

**a - Environments:**

- \* Both closed and opened.

**b - Working surfaces:**

- \* Level surfaces enough compact and not much irregular as:
  - Ceramics.
  - Wood.
  - Marble.
  - Concrete.
  - Asphalt.
  - Various plastic materials.
  - Carpets

**c - Nature of the materials to remove:**

- \* Dust.
- \* Dirt in general.
- \* Mould and rubble.
- \* Not excessively heavy objects of considerable dimensions.

### NOT CONSENTED USES

**a - Environments:**

- \* In presence of inflammable materials.

**b - Working surfaces:**

- \* With gradients exceeding 2%.
- \* Particularly irregular.
- \* Particularly wet.

**c - Kind of materials:**

- \* Lighted cigarettes-end or any other material that could cause combustion of debris inside the waste compartment.
- \* Toxic materials.
- \* Oils
- \* Chemical materials.
- \* Filiform materials.

### CAUTION!!!!

Minimum working temperature      -20°C (-4°F)  
Maximum working temperature      +40°C (+104°F)

**Do not leave the unused machine exposed to UV rays because they could damage the plastic cover.**

## UNPACKING AND SETUP OF THE MACHINE

1- Remove the packing and make sure of the machine integrity.

2- Before using the machine proceed in this way:

2.1 Take from the **Waste Hopper Table B-1**  
the **Side Broom – Table A-20**

2.2 Unscrew the **screw and washers Table A-24** from the **Gearmotor Table A-15**.  
Insert the broom on the gearmotor axle having the key slot matching the key, leaving the spacer between the broom and the gearmotor, then fix it with the screw and washers

2.3 Remove the **Cover Table A- 1** unscrewing the four screws that keep it fixed on the machine frame.

2.4 Make sure that the input voltage of the **Battery-charger** corresponds to the input voltage available.

The machine leaves the factory set for an input voltage of 120 VAC

For input voltages of 210/240 VAC :

Follow **connections as per Table B – 5**

2.5 Connect the battery terminals paying attention to the correspondence of polarities.

2.6 Provide for the charge of the battery (See the following directions PAGE 4 – **Battery-charger**).

### MACHINE SETUP

**State of rest:** the machine can be placed whether with the handle folded down or with the handle in vertical position.

## MACHINE STARTING UP AND OPERATION

### **Main broom**

Operating the **switch (Figure 1-2)** the main broom **Table C- 14** starts to work reaching immediately the running speed. The lighting of a green LED signals the regular operation.

With the main broom working it is possible to operate:

### **Side broom**

Operating the **switch (Figure 1-3)** the side broom will start working.  
To adjust the side broom operate on the **knob (Table A- 22)**.

### **Vacuum**

Operating the **switch (Figure 1-4)** the centrifugal electric motor fan starts to work.

### **Electric filter-shaker**

With the battery connected, the electric filter-shaker is always active.

- The operation takes place pressing the **push-button (Figure 1- 1)**.
- With the machine in movement, before operating the filter-shaker, it is suggested to switch-off the vacuum, **switch (Figure 1- 4)**.
- With the machine still and the hopper out, switch-off the suction and the main broom **switch (Figure 1 - 2)** , before operating the filter-shaker.

## Battery

- The “**discharged battery**” limit is signalled by the lighting of a **red Led** and afterwards by the motors switching off.
- To complete the work switch-off for a while the **switch (Figure 1- 2)**.
- To make use of a further residual of charge, switch-off the side broom **switch (Figure 1- 3)**.

**CAUTION: In case of prolonged inactivity of the machine disconnect the battery terminals.**

### **Battery charger**

To charge the battery:

- **Make sure that the transformer connections have been set for the suitable voltage from 90 up to 240 volts Figure 3 – Page 9.**
- Use the **cable** already connected to the machine (**Table A- 11**), insert the plug in any suitable AC. outlet.
- The time required for the complete recharge varies from 8 to 15 hours, depending on the power grid condition.
- During the charge all functions are automatically switched-off.

**CAUTION: during the battery charging avoid to have contacts with parts of the circuit concerned by the network voltage.**

## ORDINARY MAINTENANCE

### Maintenance and replacement of the main broom:

#### a- Cleaning:

Check periodically, according to the use of the machine, the wear conditions of the **main broom** **Table C-14**. To carry out this operation, the following tools are needed:

- Heavy-duty gloves.
- Breathing mask.
- Scissors
- Pliers

Switch off the machine. In order to see the main broom:

- Remove the **waste container (Table B-1) and the battery (Table A- 9)**.
- Tilt the machine.
- Clean away from the broom any filaments or other.

#### b- Adjustment:

To adjust the distance of the main broom to the ground, operate the cam **Table A-26** from position 1 to position 5.

#### c- Replacement:

If the broom wear is such to require it, replace the broom :

- Release the driving belt **Table A - 14**.
- Disassemble the **internal flap Table C- 13**.
- Release the **belt Table A- 14**.
- Unscrew the **eccentrics Table C- 1**
- Remove the broom unit from its housing.
- Remove the two **spacers Table C- 2 Table C- 3** .
- Remove the **pulley-hub Table C- 5** and the **free hub Table C- 6**.
- **Using a new broom, carry out the operations in reverse order.**

### Maintenance and replacement of the side broom:

With procedures and tools similar to the above mentioned ones.

#### a- Adjustment:

- Act on the **knob Table A- 22**

#### b- Replacement:

- Unscrew the fastening screw **Table A - 24** and replace the **broom (Table A- 20)**, paying attention to the flat key that lock the broom to the gearmotor shaft.

### **Maintenance and replacement of the filter:**

To carry out this procedure the following tools are needed:

- Heavy duty gloves.
- Breathing mask.

#### **a- Cleaning / Replacement:**

- Withdraw the split pin Table B- 11 from the hole of the Pin Table B -11 that hold the filter-support (Table B- 10) at the machine frame.
- Remove the filter (Table B-12) and check the wear condition.
- If necessary, replace it.
- If not, proceed to clean it, beating it on the floor and, if possible, blow with compressed air from the upper side at a distance of about 15 cm.
- Reassemble carrying out operations in reverse order.

### **Maintenance and replacement of the flaps:**

- Periodically check the conditions of flaps' rubbers.

#### **a- Replacement of the front flap rubber:**

- Unscrew the rod (Table C- 7).
- Unscrew the front strap iron (Table C- 9).
- Unscrew the straps iron (Table C- 8) -(Table C- 10).
- Replace the rubber (Table C- 13).
- Reassemble following the same operations in reverse order.

#### **b- Replacement of the side flap's rubber:**

- Unscrew the bus-bar (Table C- 11).
- Replace the rubber (Table C- 14).

#### **c- Replacement of the back flap's rubber:**

- Unscrew the back strap iron (Table C- 9).
- Replace the rubber (Table C- 12).

**Maintenance and replacement of the electronic circuit board:**

In case of non-operation of some electrical components, check out the integrity of the fuses:

Figure 2 - F2

In case of a non good operation of the function of battery charging, check out the integrity of the fuses:

Figure 2 - F1

Figure 3 - FUN

Figure 3 - FUR

If necessary, replace them with integral ones.

**If this operation does not bring to the drawback elimination, turn to an authorized workshop.**

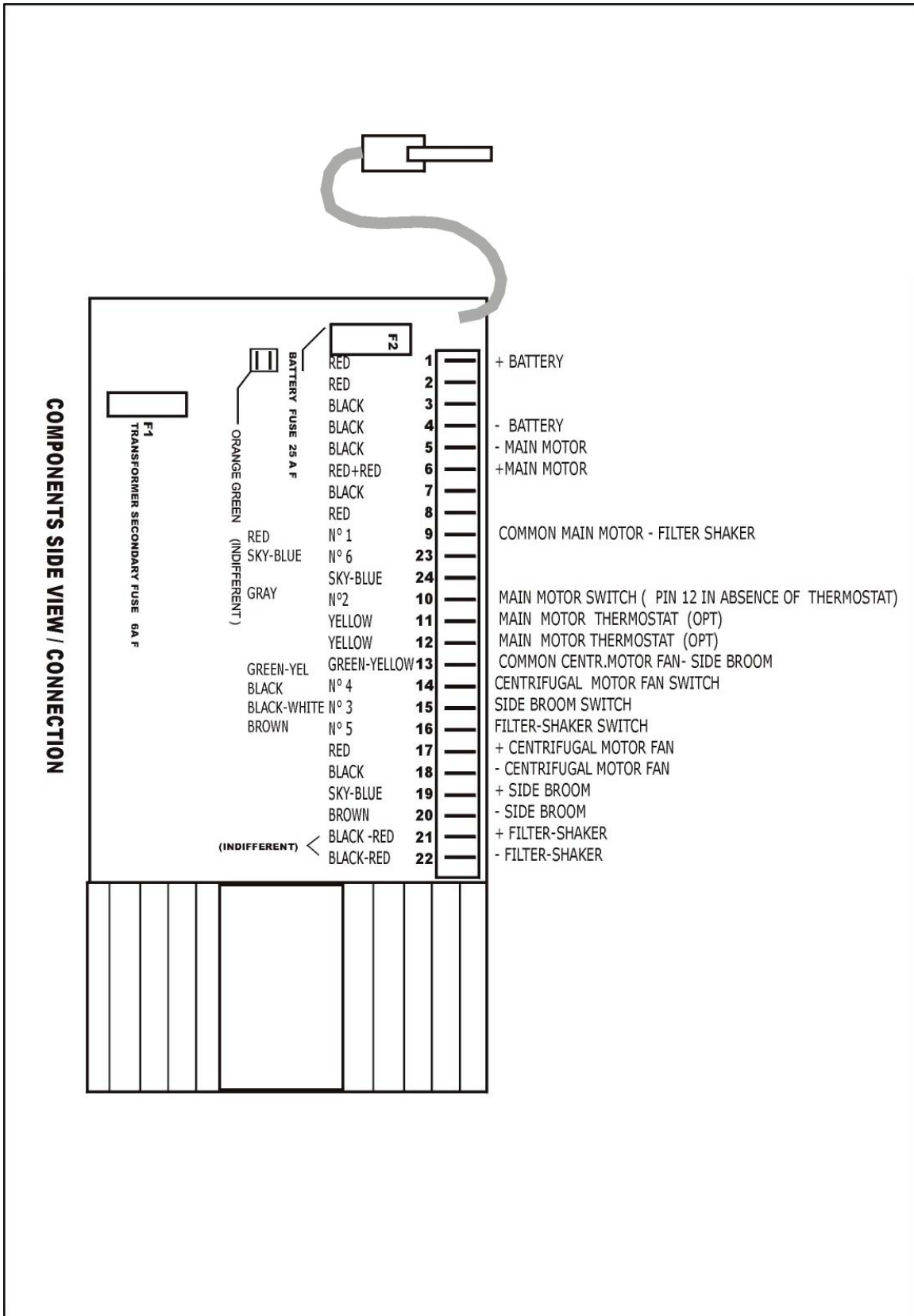

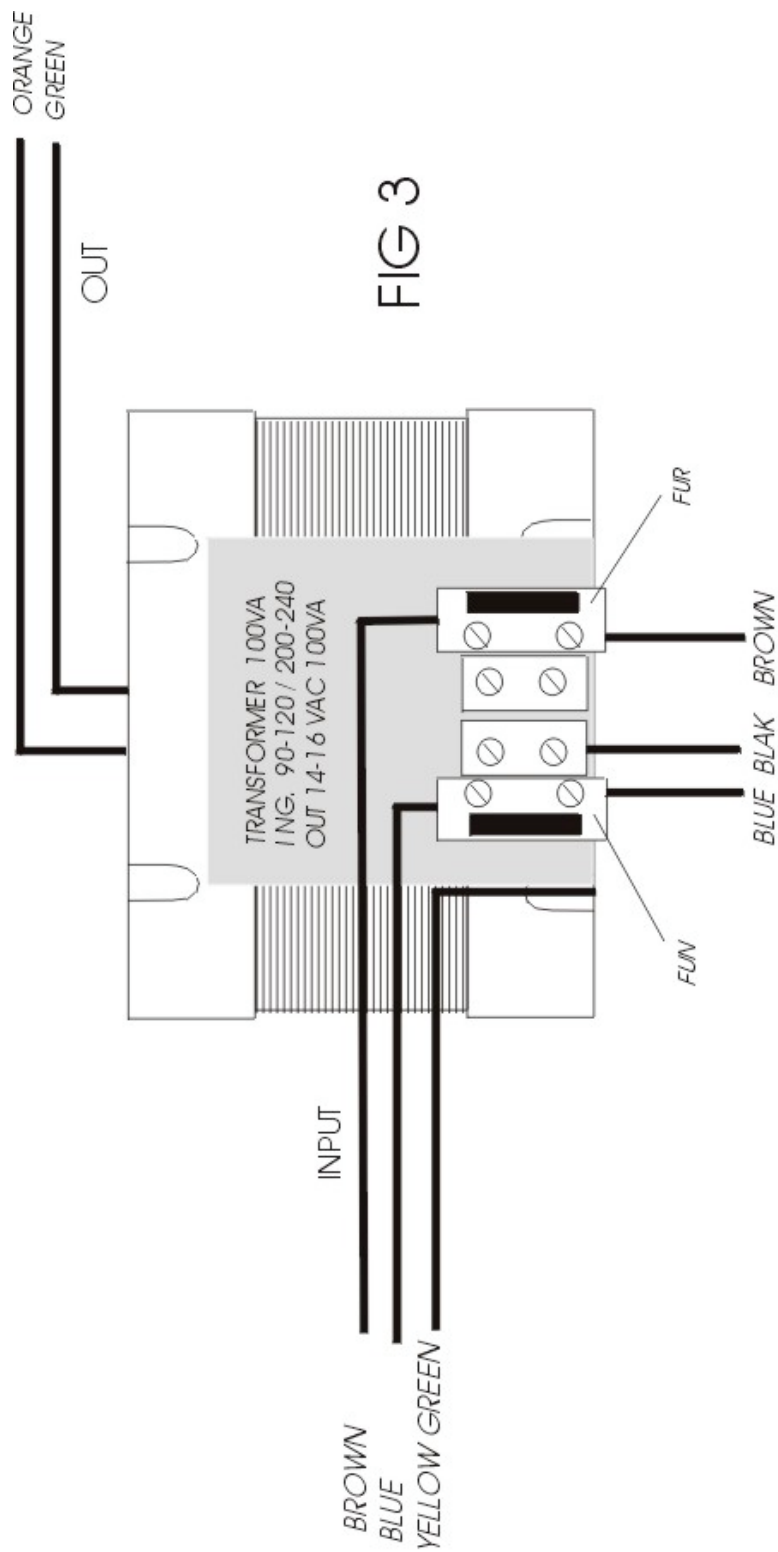

**CONNECTION 90- 120V:** CONNECT COLOUR BLAK TO POINT B AND COLOUR BROWN TO POINT C  
**CONNECTION 200- 240V:** CONNECT COLOUR BROWN TO POINT B AND COLOUR BLAK TO POINT C

TABLE A-SPARE PARTS

POS.	CODE	DESCRIPTION
1	P 030 33110	COVER
2	3 017 E400B	WIRED COMMANDS CONSOLE (SWITCHES BOX)
3	4 100 33201	HANDLE
4	K 999 00001	HANDLE ADJUSTING KIT
5	K 999 00002	HANDLE PIVOT KIT
6	4 350 33200	BATTERY STRAP
7	8 600 33030	GEL SEALED BATTERY 12V 42AH
8	3 015 A400B	VACUUM FAN UNIT
9	4 310 33160	MOTOR FAN GASKET
10	7 720 33060	MOTOR
11	4 281 33090	PULLEY
12	8 441 21579	BELT
13	K 999 00003	LEFT BUMPER WHEEL KIT
14	E MIC 01001	MICROSWITCH
15	4 090 33150	GEARMOTOR SUPPORT
16	8 250 33010	PIVOT
17	K 999 00004	SIDE BROOM ARM PIN KIT
18	K 999 00005	SIDE BROOM LOCKING PIN KIT
19	4 290 33400	SIDE BROOM ADJUSTING SPRING
20	8 040 05020	SIDE BROOM ADJUSTING KNOB
21	7 750 33030	GEARMOTOR
22	4 350 33084	SIDE BROOM
23	7 602 33003	SIDE BROOM FASTENING KIT
24	K 999 00006	RIGHT BUMPER WHEEL KIT
25	4 240 33270	SPACER
26	4 300 33160	SIDE BROOM TRACTION SPRING
27	7 620 33010	FILTER-SHAKER ELECTROMAGNET

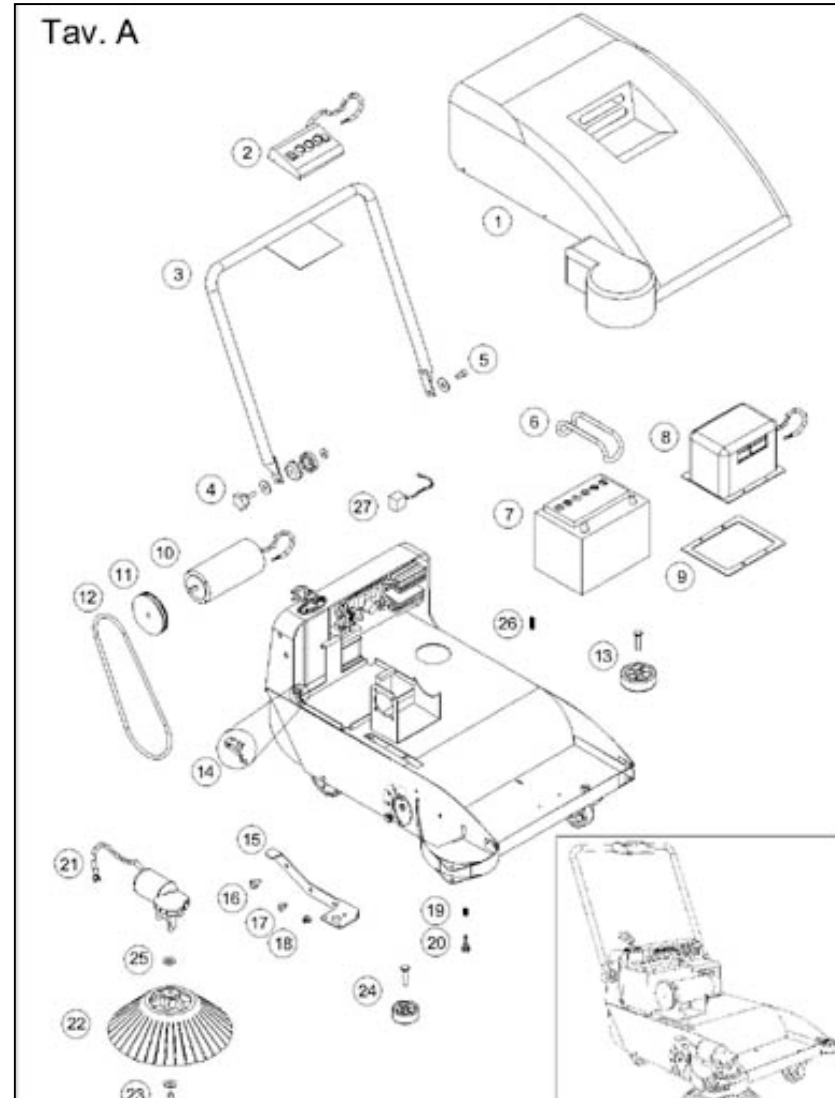



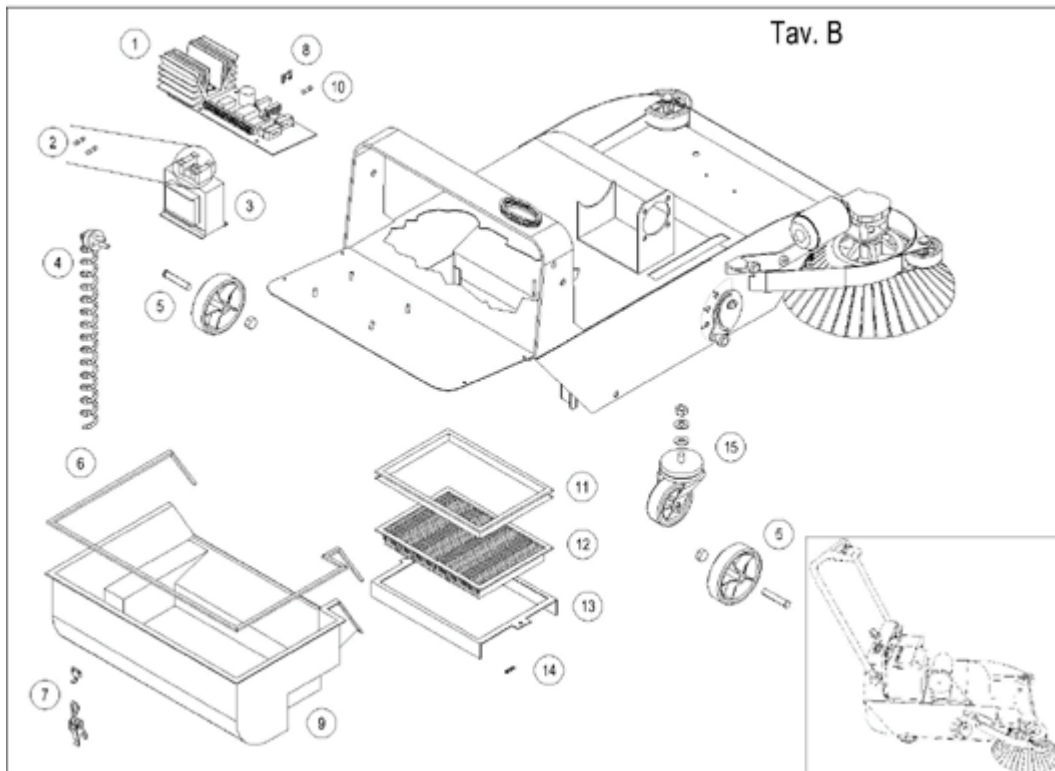

TABLE B - SPARE PARTS -

POS.	CODE	DESCRIPTION
1	4 018 A400B	ELECTRONICS CONTROL BOARD
2	E FUS 01003	FUSE 1.5 A
3	4 018 33011	TRANSFORMER
4	S CAV 01010	COILED CABLE
5	K 999 00007	REAR WHEEL KIT
6	4 310 33140	GASKET
7	8 119 33100	CLAMP LEVER
8	E FUS 02002	FUSE 30 A
9	4 021 33100	HOPPER
10	E FUS 01001	FUSE 10A
11	4 310 33150	FILTER SUPPORT GASKET
12	3 013 B400B	FILTER
13	4 070 33110	FILTER HOLDER BRACKET
14	4 650 02042	SPLIT PIN
15	K 999 00008	FRONT WHEEL KIT

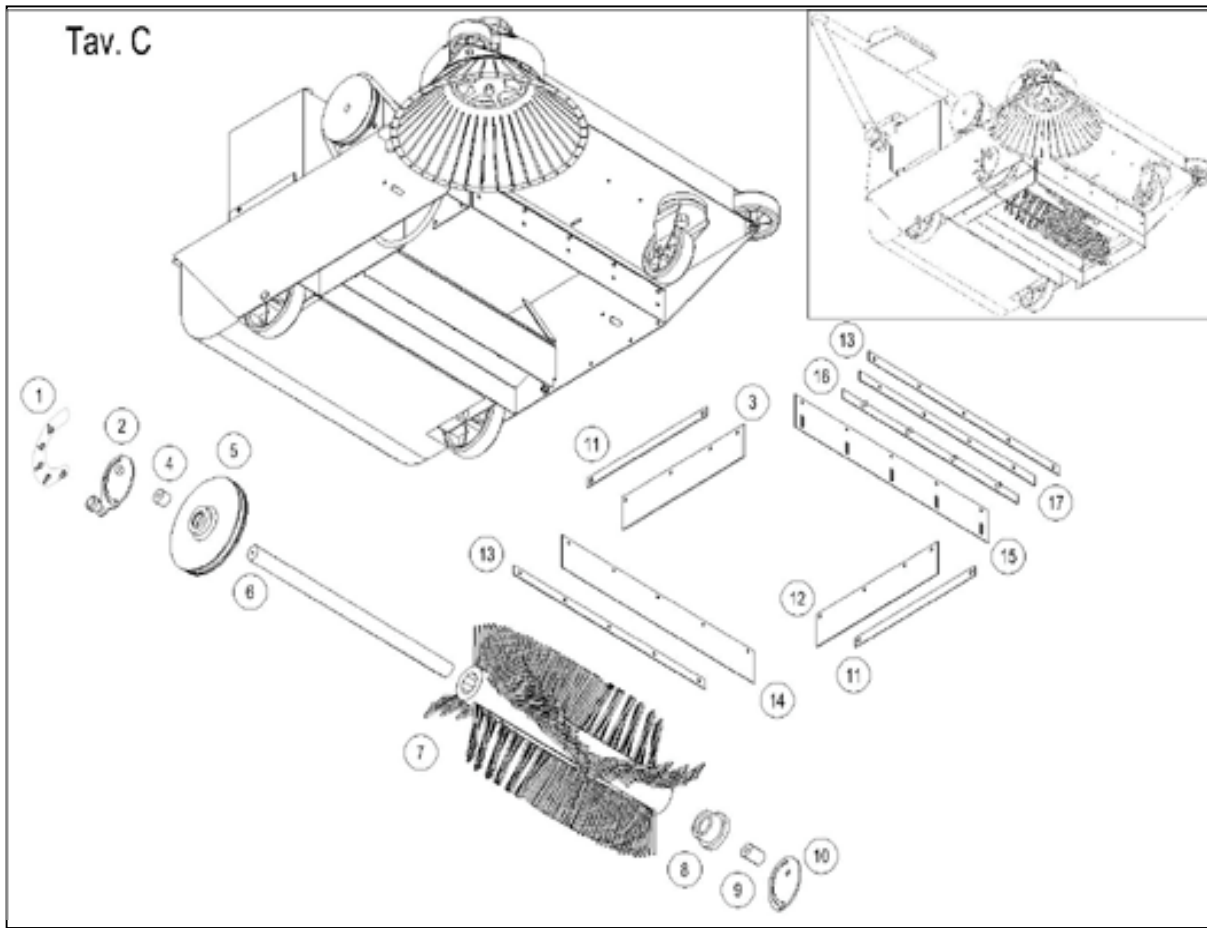

TABLE C - SPARE PARTS -

POS.	CODE	DESCRIPTION
1	4 202 04444	SIDE BROOM ADJUSTMENT LABEL
2	K 999 00009	LEFT CAM KIT
3	4 320 33201	SIDE FLAP RUBBER
4	4 240 33250	MAIN BROOM SHORT SPACER
5	4 260 33170	MAIN BROOM PULLEY HUB
6	4 270 33151	MAIN BROOM SHAFT
7	4 340 33151	MAIN BROOM
8	4 260 33160	MAIN BROOM FREE HUB
9	4 240 33260	MAIN BROOM LONG SPACER
10	4 170 33016	MAIN BROOM ADJUSTING RIGHT CAM
11	4 140 33251	SIDE FLAP STRAP
12	4 320 33211	LEFT SIDE FLAP RUBBER
13	4 140 33252	FRONT/REAR FLAP STRAP
14	4 320 33202	REAR FLAP RUBBER
15	4 320 33224	FRONT FLAP RUBBER
16	4 140 33256	FRONT FLAP INTERNAL STRAP
17	4 140 33258	FRONT FIXED FLAP STRAP
18	4 140 33170	MAIN BROOM GASKET



## Warranty Policy

### Limited Warranty

**Eagle Power Products (EPP) warrants new cleaning equipment against defects in material and workmanship under normal use and service to the original purchaser as detailed below.**

### 10 Years

**Subject to the conditions stated below, EPP warrants polyethylene tanks and housings to be free from defects in materials and workmanship for a period of ten years.**

### 3 Years

**Subject to the conditions stated below, EPP warrants all automatic scrubber components to be free from defects in materials and workmanship for a 3-year period. Parts replaced or repaired are warranted for the remainder of the original warranty period.**

### 1 Year

**Subject to the conditions stated below, EPP warrants all other cleaning equipment components to be free from defects in materials and workmanship for a 1-year period. Parts replaced or repaired are warranted for the remainder of the original warranty period. Batteries are prorated for one year.**

**EPP will furnish and charge for replacement parts, including transportation, to the original owner through an EPP authorized service center. If the part is returned within 30 days and is found defective, the owner will be credited for the cost of the replacement part including shipping and handling.**

Labor charges are covered for one year from the date of purchase if provided by an authorized EPP service center. Travel is covered for 90 days for battery operated equipment only.

Wear items exempt from warranty include belts, carbon brushes, power cords, wheels, pad drivers, clutch plates, brushes, pads, handle grips, filters, screens, throttle cables, and squeegees.

This warranty shall not apply to failures caused by misuse or abuse, improper maintenance as stated in the operation manuals, use of unauthorized repair parts, repairs by other than an EPP authorized service center, and damage in transit.

EPP disclaims and denies any liability for any direct, indirect, special incidental or consequential damage which may be suffered as a result of sale, delivery, servicing, use, loss of any product, downtime, labor, freight, or other charges not expressly included herein.

Date Purchased: \_\_\_\_\_

Model Number: \_\_\_\_\_

Serial Number: \_\_\_\_\_

Please be sure to record this information. This information will be necessary for future warranty claims.