



## Electronic Service Manuals

This electronic document is provided as a service to our customers. We do not create the contents of the information contained in this document. Should you have detailed questions pertaining to the information contained in this document, you may contact Michco, or the manufacturer which provided the original information in this electronic deliverable. Michco's only part in this electronic deliverable was the electronic assembly process. By providing this manual on line we are not guaranteeing parts availability.

You may contact Michco through the following methods:

Phone (517) 484-9312 or (800) 331-3339

2011 N. High St. -- Lansing, Michigan -- 48906

Fax: (517) 484-9836

Email: [CustServe@Michco.com](mailto:CustServe@Michco.com)

Web site: [www.Michco.Com](http://www.Michco.Com)

Parts Web site: [www.FloorMachineParts.Com](http://www.FloorMachineParts.Com)

Order Parts on Line at:

**[www.FloorMachineParts.Com](http://www.FloorMachineParts.Com)**

Directly to Parts & Service:

By Email: **[Shop@Michco.com](mailto:Shop@Michco.com)**

By Fax: (517) 702-2041

By Voice: Use numbers above.

**Serving the Cleaning Industry Since 1922**

Notice: All copyrighted material remains property of original owners, all trademarks are property of respective owners. Manuals are subject to Manufacturer's reproduction limitations. Originals or reproductions were provided by manufacturers through a request. We make no warranty as to the correctness of information provided in this document and you assume all risk. By placing these manuals on line we are not declaring our corporation to be an manufacturer authorized dealer or provider, please check our web site for authorized manufacturers we represent.

# Eagle Power



## JOB EXTRACTOR

# OPERATIONS MANUAL

# OPERATOR SAFETY INSTRUCTIONS

## WARNING



**DANGER:** Failure to read and observe all DANGER statements could result in severe bodily injury or death. Read and observe all DANGER statements found in your Owner's Manual and on your machine.



**CAUTION:** Failure to read and observe all CAUTION statements could result in damage to the machine or to other property. Read and observe all CAUTION statements found in your Owner's Manual and on your machine.



**WARNING:** Failure to read and observe all WARNING statements could result in injury to you or to other personnel; property damage could occur as well. Read and observe all WARNING statements found in your Owner's Manual and on your machine.

---



**DANGER:** Failure to read the Owner's Manual prior to operating or attempting any service or maintenance procedure to your Eagle Power Products machine could result in injury to you or to other personnel; damage to the machine or to other property could occur as well. You must have training in the operation of this machine before using it. If you or your operator(s) cannot read English, have this manual explained fully before attempting to operate this machine.



**DANGER:** Operating a machine that is not completely or fully assembled could result in injury or property damage. Do not operate this machine until it is completely assembled. Inspect the machine carefully before operation. Use only as described in this manual. Use only Eagle Power Products recommended attachments.



**DANGER:** Machines can cause an explosion when operated near flammable materials and vapors. Do not use this machine with or near fuels, grain dust, solvents, thinners, or other flammable materials.



**DANGER:** Using a machine with a damaged power cord could result in an electrocution. Do not use the machine if the power cord is damaged. Do not use the electrical cord to move the machine. Keep cord away from heated surfaces. Do not unplug by pulling on the cord; grasp the plug, not the cord.



**DANGER:** Electrocution could occur if maintenance and repairs are performed on a unit that is not properly disconnected from the power source. Disconnect the power supply before attempting any maintenance or service.



**WARNING:** Operating a machine without observing all labels, decals, etc., could result in injury or damage. Read all machine labels before attempting to operate the machine. Make sure all of the labels are attached or fastened to the machine. Get replacement labels and decals from your Eagle Power Products distributor.



**WARNING:** Electrical components can "short-out" if exposed to water or moisture. Keep the electrical components of the machine dry. Always store the machine in a dry area.



**WARNING:** Use of this machine to move other objects or to climb on could result in injury to the operator or damage to the machine. Do not use this machine as a step or furniture. Do not allow to be used as a toy. Close attention is necessary when used by or near children.



**WARNING:** Moving parts of this machine can cause injury and/or damage. Keep hands, feet, loose clothing, hair, fingers, and all parts of the body away from openings and moving parts.



**WARNING:** Electrocution could occur if you handle the plug or appliance with wet hands. Do not handle plug or appliance with wet hands.



**WARNING:** Damage could occur to machine if openings are blocked. Do not put any object into openings. Do not use with any opening blocked; keep free of dust, lint, hair, and anything that may reduce air flow.



**WARNING:** Injury could occur to the operator or the machine if used without the dust bag and/or filters. Do not use the machine without the dust bag and/or filters in place.



**WARNING:** Injury to the operator and/or damage to the machine could occur when cleaning on stairs, unless extra caution is used. Use extra caution when cleaning on stairs.



**WARNING:** To reduce the risk of electrical shock, always use a 3-wire electrical system connected to the electrical ground. Whenever possible connect the machine to an outlet protected by a ground fault interrupter (GFCI). See “Grounding Instructions.”

## 120 Volt Machine Instructions For Connection To The Power Supply And The Electrical Ground

This machine must be connected to the electrical ground to protect the operator from electric shock. The machine has an approved power cord with three conductors and a plug with three terminals. Connect the plug to a receptacle that has three holes and is connected to the electrical ground. The green (or green and yellow) conductor in the cord is the ground wire. Never connect this wire to any terminal other than the ground terminal.

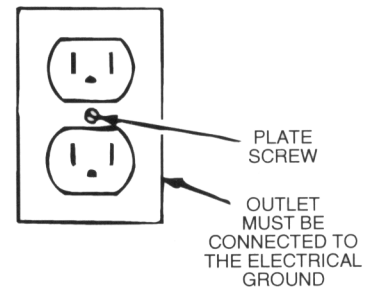

This machine uses a 120 volt AC 60 cycle electrical circuit. Make sure you have the correct frequency and voltage before connecting the power cord to an outlet. The machine has a plug as shown in Figure 1. If a receptacle connected to the electrical ground as shown in Figure 1 is not available, have one installed by an electrical contractor. Do not use an adapter.



**WARNING:** To reduce the risk of electric shock, protect the machine from rain. Keep the machine in a dry area.



**WARNING:** To reduce the risk of electric shock, always use a 3-wire electrical system connected to the electrical ground. Whenever possible connect the machine to an outlet protected by a ground fault interrupter (GFCI).



**WARNING:** Do not cut, remove or break the ground pin. If the outlet does not fit the plug, consult your electrical contractor.



**WARNING:** Have worn, cut or damaged cords and plugs replaced by an authorized service person.

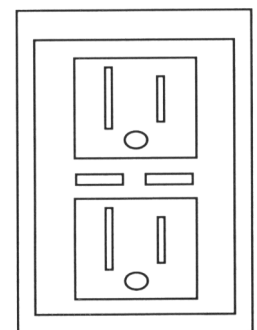

## IMPORTANT INSTRUCTIONS

- Before use, the equipment must be correctly assembled with all its components.
- Check that electrical outlet is correct for use with the plug on the machine.
- Before connecting, check that the specified motor voltage corresponds to the main voltage available.
- Never use the equipment near inflammable, explosive or toxic substances: sparks from the motor could cause dangerous reactions.
- Always unplug the machine from electrical outlet when leaving machine unattended or before attempting any repair.
- Service and repair should be done by qualified personnel only. Use only genuine Eagle Power Products replacement parts.

## JOB EXTRACTOR - HEAD ASSEMBLY

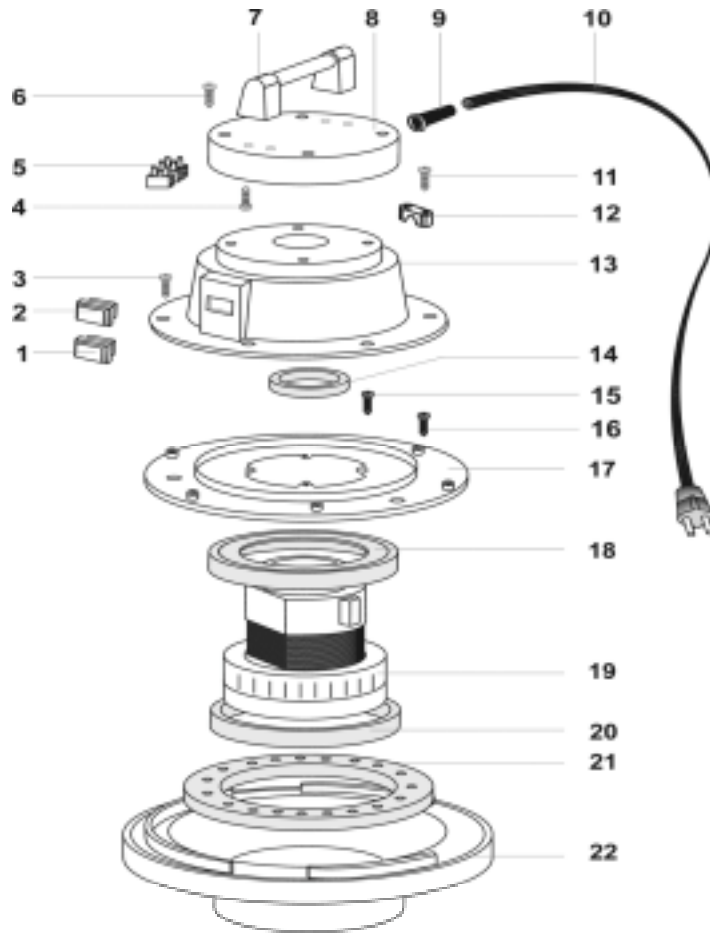

### JOB EXTRACTOR - HEAD ASSEMBLY

POS.	PART #	DESCRIPTION	QTY.
1	S80756	ANTI-SPLASH SWITCH, GREEN	1
2	S80484	SWITCH, ON-OFF	1
3	S81006	SCREW, (PHILLIPS) M5 X 20	6
4	S81006	SCREW, (PHILLIPS) M5 X 20	2
5	S80140	TERMINAL BLOCK	1
6	S81026	SCREW, M2 X 30	4
7	S81068	LIFT HANDLE, JOB	1
8	S81183	ANTIFLAME COVER 500	1
9	S80138L	STRAIN RELIEF, "L"	1
10	S81122	ELECTRIC CORD, 3 X 16 AWG	1
11	S81006	SCREW, (PHILLIPS) M5 X 20	2
12	S80139	CLAMP, CORD	1
13	S82267	COVER, HEAD, JOB	1
14	S83969	GASKET, MOTOR EXHAUST	1
15	S81006	SCREW, (PHILLIPS) M5 X 20	4
16	S81005	SCREW, M5 X 14	2
17	S82268	COVER PLATE, JOB	1
18	S83901	L GASKET W/O H H=5.5	1

JOB EXTRACTOR - HEAD ASSEMBLY

POS.	PART #	DESCRIPTION	QTY.
19	S81120S	MOTOR, 1000W/120V 60HZ	1
20	S83901	L GASKET W/O H H=5.5	1
21	S83866	DISK, NOISE REDUCTION	1
22	S82636	LOWER BASE	1

## JOB EXTRACTOR - MOTOR ASSEMBLY

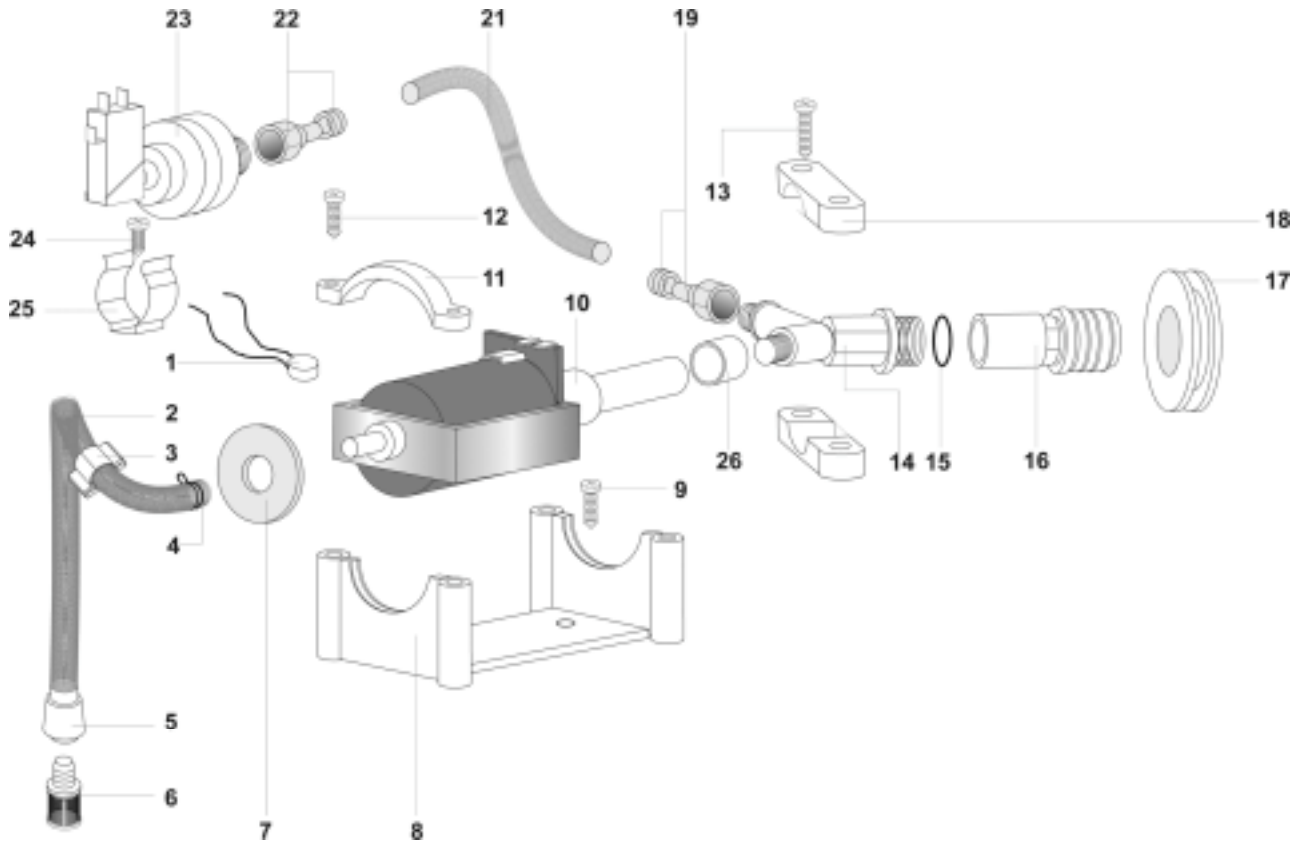

### JOB EXTRACTOR - MOTOR ASSEMBLY

POS.	PART #	DESCRIPTION	QTY.
1	S83037	COMPLETE THERMOSTAT	1
2	S82743	HYDROLITIC HOSE	1
3	S82660	CLAMP	1
4	S82659	DOUBLE-WIRE CLAMP	1
5	S83036	FILTER HOUSING	1
6	S82689	FILTER, JOB	1
7	S82571	WASHER, D 32 X 13 X 3	2
8	S82603	PUMP, U SUPPORT	1
9	S81005	SCREW, M5 X 14	2
10	S80799	PUMP, 120V, 60HZ	1
11	S82602	PUMP, U BRACKET	2
12	S81979	SCREW, M5 X 25	4
13	S81050	SCREW, M5 X 35	2
14	S83096	Y CONNECTOR	1
15	S81610	D-RING, 9	1
16	S83689OTT	1/4" QUICK DISCONNECT, FEMALE	1

**JOB EXTRACTOR - MOTOR ASSEMBLY**

<b>POS.</b>	<b>PART #</b>	<b>DESCRIPTION</b>	<b>QTY.</b>
17	S81502	GROMMET	1
18	S82604	FIXING BOLT	2
19	S80728	FITTING, 1/4" F	1
21	S83702	HOSE, 220 MM	1
22	S80792	FITTING, 1/8"	1
23	S83919	PRESSURE SWITCH	1
24	S81005	SCREW, M5 X 14	1
25	S81113	RETAINING CLIP	1
26	S86116	SLEEVE	1



## JOB EXTRACTOR-BUCKET ASSEMBLY

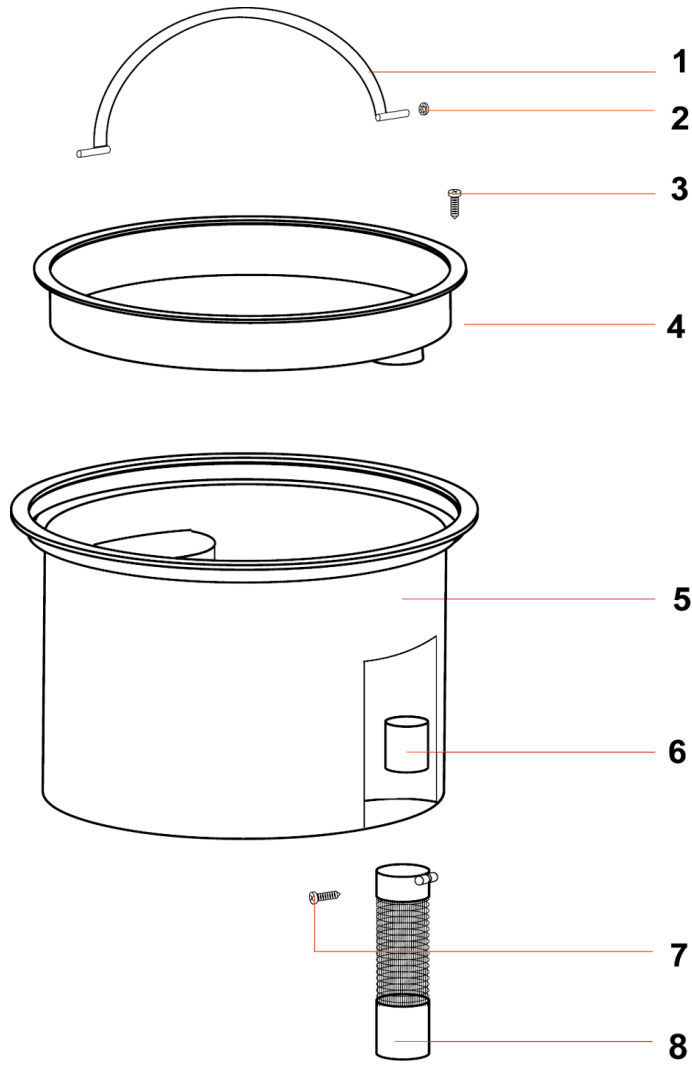

### JOB EXTRACTOR-BUCKET ASSEMBLY

POS	PART #	DESCRIPTION	QTY.
1	S82577	INOX HANDLE	1
2	S82573	WASHER, D6	2
3	S82622	SCREW, TC INOX	5
4	S82596	BUCKET COVER	1
5	S82595	BUCKET, LT =11, PARTIAL	1
6	S82580	FLOAT SHUT OFF	1
7	S82622	SCREW, TC INOX	1
8	S82592	FILTER, BUCKET	1

## JOB EXTRACTOR - TANK ASSEMBLY

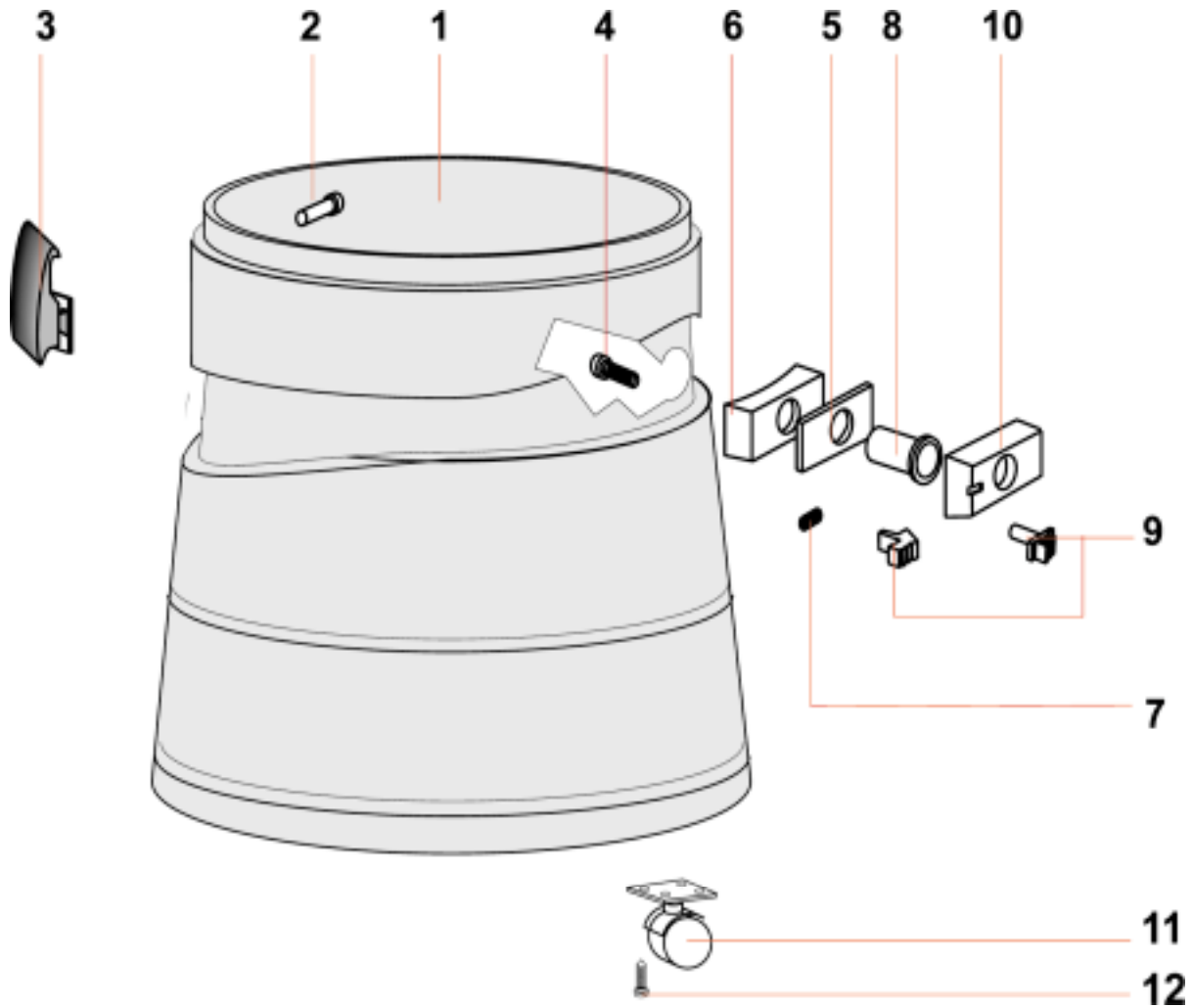

## JOB EXTRACTOR - TANK ASSEMBLY

POS.	PART #	DESCRIPTION	QTY.
1	S82669	TANK	1
2	S81300	RIVET	4
3	S81847	CLAMP, TANK	2
4	S81050	SCREW, M5 X 35	4
5	S82846	GASKET	1
6	S82585	RETAINER, TANK ADAPTOR	1
7	S82608	SPRING, PUSH BUTTON	1
8	S82593	DEFLECTOR, TANK	1
9	S82594	PUSH BUTTON, 2 PIECE	1
10	S82583	ADAPTOR, HOSE	1
11	S82572	CASTER WHEEL, SJOB	6
12	S82680	SCREW, M4 X 15	24

## JOB EXTRACTOR - WAND/TRIGGER ASSEMBLY

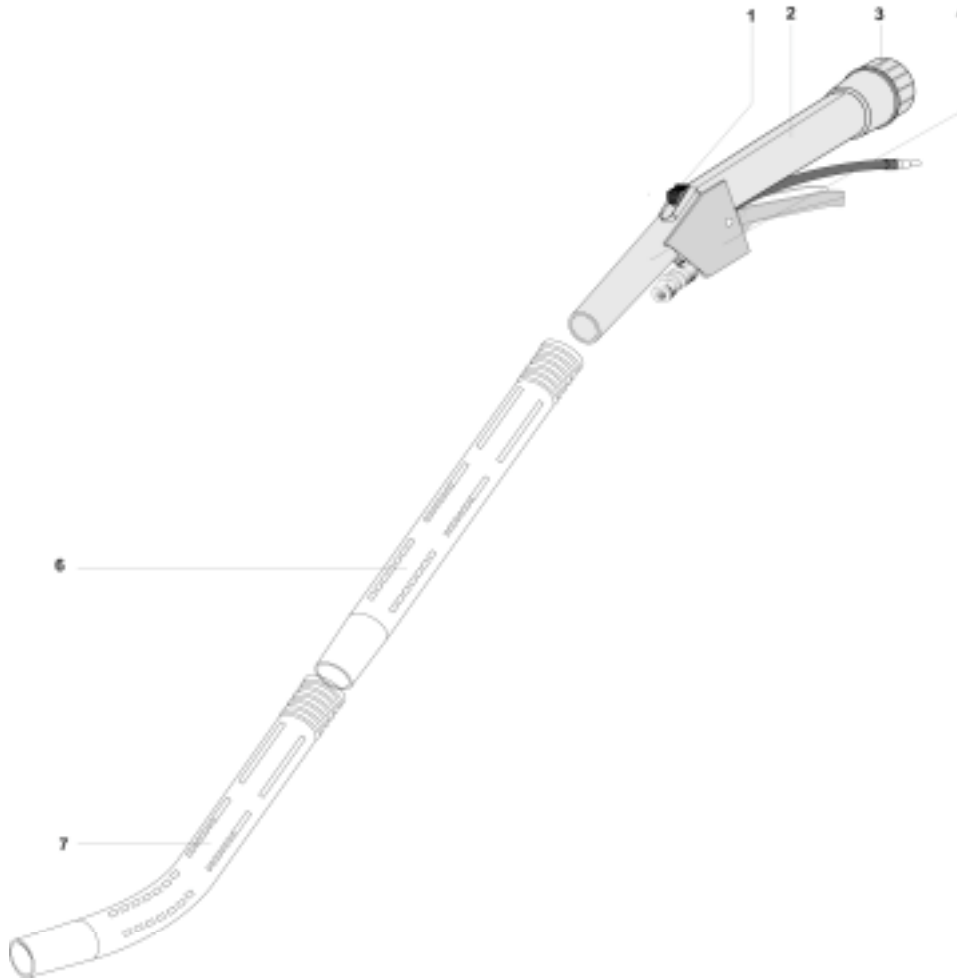

### JOB EXTRACTOR - WAND/TRIGGER ASSEMBLY

POS	PART #	DESCRIPTION	QTY.
1	S86167	BUTTON	1
2	S86158A	CURVED PLASTIC	1
3	S86188	CUFF	1
4	S86160OTT	TRIGGER	1
6	S86240IDRO	WAND, STRAIGHT	1
7	S86261IDRO	WAND, CURVED	1
	S86175	COMPLETE TRIGGER	

## JOB EXTRACTOR - WAND/HEAD ASSEMBLY

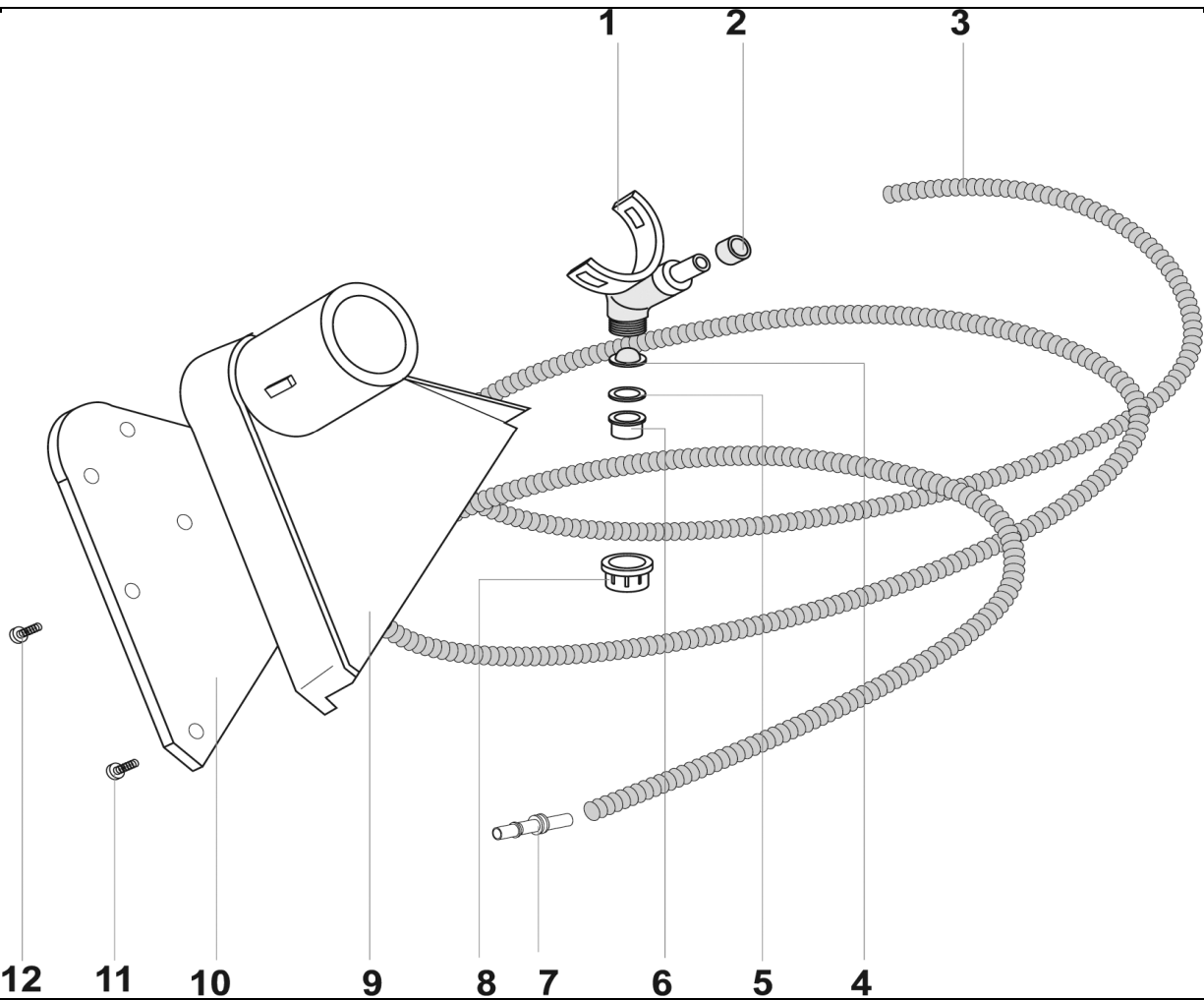

### JOB EXTRACTOR - WAND/HEAD ASSEMBLY

POS.	PART#	DESCRIPTION	QTY.
1	S82732	SPRAY TIP HOUSING	1
2	S83171	PLASTIC SLEEVE	2
3	S82747	HYDROLITIC HOSE	1
4	S82711	FILTER	1
5	S83060	GASKET	1
6	S83071	NOZZLE	1
7	S83664OTT	QUICK DISCONNECT, MALE	1
8	S82713	CAP	1
9	S82730	EXTRACTION HEAD	1
10	S82731	PLATE	1
11	S82727	SCREW	2
12	S86252	SCREW	5
1-8	S83572	COMPLETE SPRAY NOZZLE ASSEMBLY	
9-12	S82753	COMPLETE EXTRACTION HEAD	
	S82724	COMPLETE EXTRACTION WAND ASSEMBLY	

## JOB EXTRACTOR - HARD FLOOR TOOL

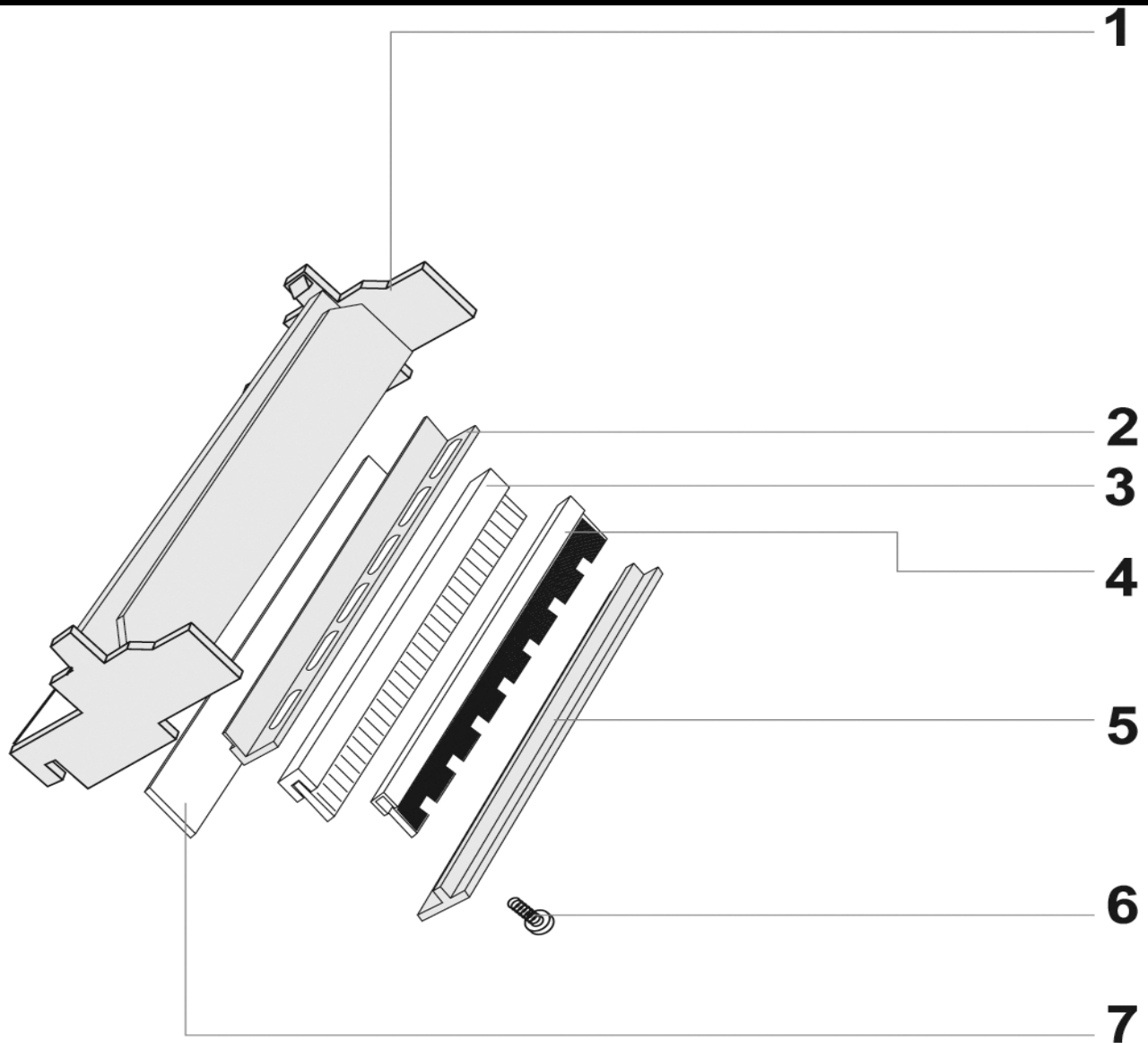

### JOB EXTRACTOR - HARD FLOOR TOOL

POS	PART #	DESCRIPTION	QTY.
1	S82733	BODY, HARD FLOOR TOOL	1
2	S82734	STRIP	1
3	S83460	BLADE, HARD FLOOR TOOL	1
4	S82748	BRUSH / FLOOR TOOL	1
5	S83047	REAR BRUSH, HARD FLOOR TOOL	1
6	S83049	SCREW	4
7	S82729	SUCTION STRIP, L=250	1
1-7	S72707	COMPLETE LIQUID TOOL	

## JOB EXTRACTOR - HOSE

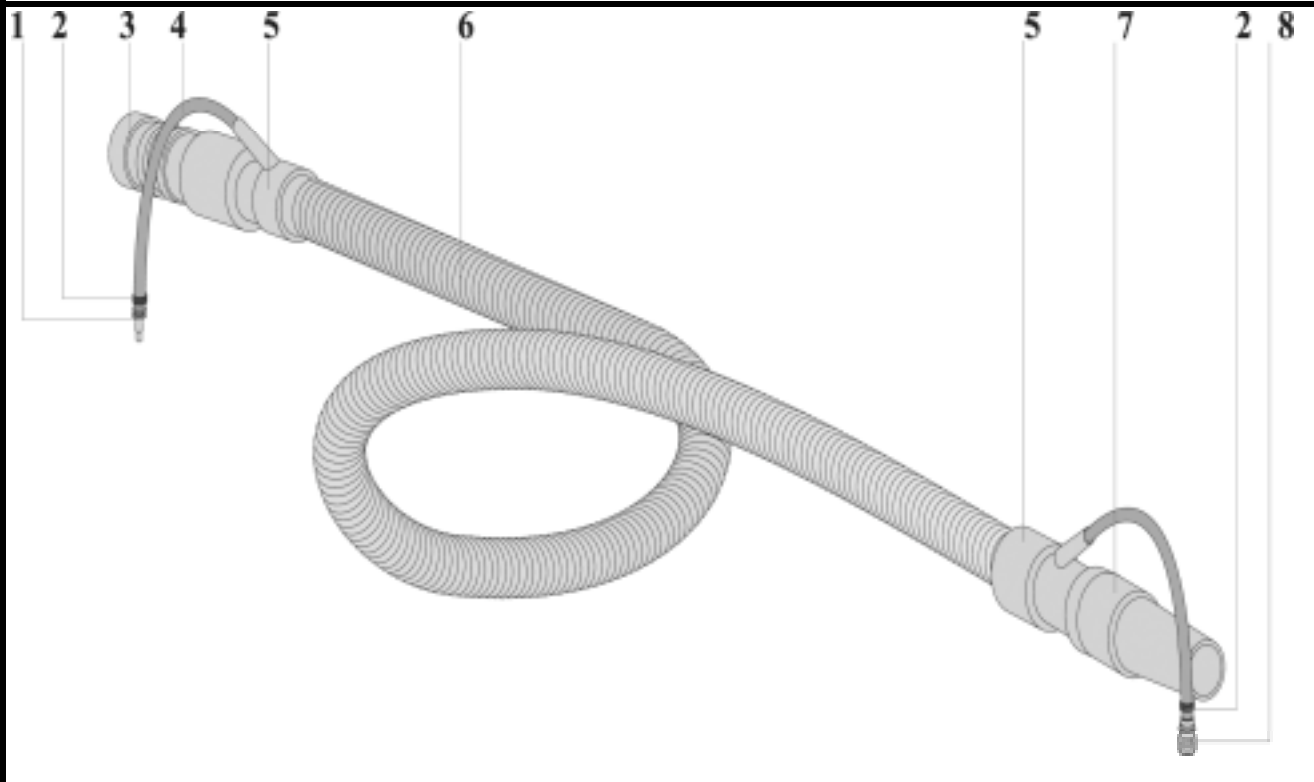

## JOB EXTRACTOR - HOSE

POS.	PART #	DESCRIPTION	QTY.
1	S73244	KIT COUPLING, MALE	1
2	S83171	PLASTIC SLEEVE	2
3	S70090	FLEXIBLE HOSE COUPLING	1
4	S82546	TUBE, BLUE	1
5	S82547	HOSE COUPLING	2
6	S70613	FLEXIBLE HOSE, D 32"	1
7	S70622	HOSE END	1
8	S83245RIC	QUICK CONNECT, FEMALE	1
ALL	S72548	COMPLETE HOSE ASSEMBLY	

## JOB EXTRACTOR - UPHOLSTERY TOOL

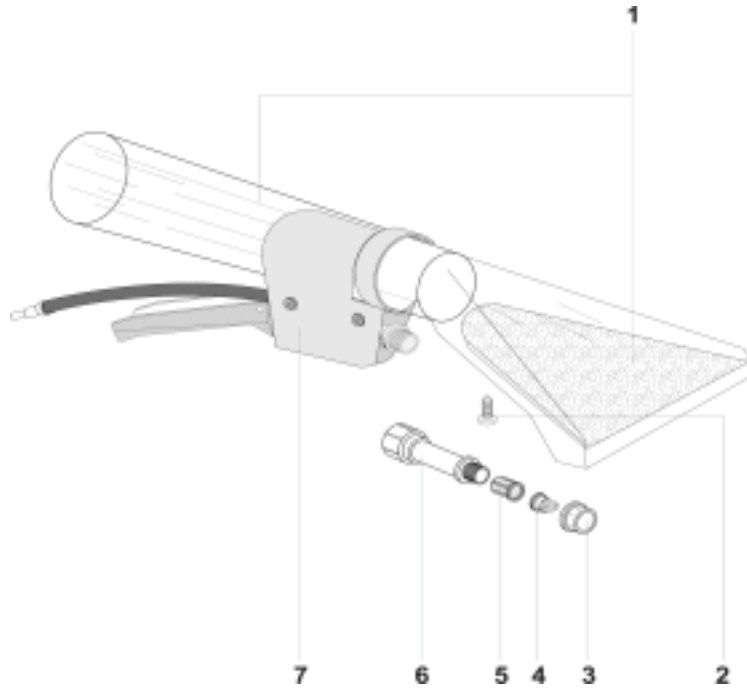

## JOB EXTRACTOR - UPHOLSTERY TOOL

POS.	PART #	DESCRIPTION	QTY.
1	S80651	UPHOLSTERY TOOL	1
2	S83257	SCREW	4
3	S82713	RETAINER	1
4	S82759	SPOTTER HAND TOOL	1
5	S82711	FILTER	1
6	S82760	ADAPTOR, HAND TOOL VALVE	1
7	S86256OTT	TRIGGER	1
ALL	S70752	COMPLETE UPHOLSTERY TOOL	

## JOB EXTRACTOR - OPTIONAL DRY KIT



### JOB EXTRACTOR - OPTIONAL DRY KIT

POS.	PART #	DESCRIPTION	QTY.
1	S70124	POLYESTER FILTER	1
2	S70123	FILTER RING	1
3	S72655	FILTER STRETCHING BASKET	1
4	S7632B	DOUBLE USE BRUSH W. STRAIGHT COUPLING	1
5	S70617	FLAT LANCE D32	1
6	S70616	SMALL TOOL	1
7	S70004	PVC BRUSH	1
ALL	S72772	COMPLETE DRY KIT	





## Warranty Policy

### Limited Warranty

**Eagle Power Products (EPP) warrants new cleaning equipment against defects in material and workmanship under normal use and service to the original purchaser as detailed below.**

### 10 Years

**Subject to the conditions stated below, EPP warrants polyethylene tanks and housings to be free from defects in materials and workmanship for a period of ten years.**

### 3 Years

**Subject to the conditions stated below, EPP warrants all automatic scrubber components to be free from defects in materials and workmanship for a 3-year period. Parts replaced or repaired are warranted for the remainder of the original warranty period.**

### 1 Year

**Subject to the conditions stated below, EPP warrants all other cleaning equipment components to be free from defects in materials and workmanship for a 1-year period. Parts replaced or repaired are warranted for the remainder of the original warranty period. Batteries are prorated for one year.**

**EPP will furnish and charge for replacement parts, including transportation, to the original owner through an EPP authorized service center. If the part is returned within 30 days and is found defective, the owner will be credited for the cost of the replacement part including shipping and handling.**

Labor charges are covered for one year from the date of purchase if provided by an authorized EPP service center. Travel is covered for 90 days for battery operated equipment only.

Wear items exempt from warranty include belts, carbon brushes, power cords, wheels, pad drivers, clutch plates, brushes, pads, handle grips, filters, screens, throttle cables, and squeegees.

This warranty shall not apply to failures caused by misuse or abuse, improper maintenance as stated in the operation manuals, use of unauthorized repair parts, repairs by other than an EPP authorized service center, and damage in transit.

EPP disclaims and denies any liability for any direct, indirect, special incidental or consequential damage which may be suffered as a result of sale, delivery, servicing, use, loss of any product, downtime, labor, freight, or other charges not expressly included herein.

Date Purchased: \_\_\_\_\_

Model Number: \_\_\_\_\_

Serial Number: \_\_\_\_\_

Please be sure to record this information. This information will be necessary for future warranty claims.



1174 Northland Drive Mendota Heights, MN 55120  
651.686.5399 Fax 651.686.5695  
www.eaglepower.com

*Eagle Power Products Sales and Service Provided by:*