

# Gold 14 14" Two Motor Upright Vacuum

## Parts Schematic

Item #85800

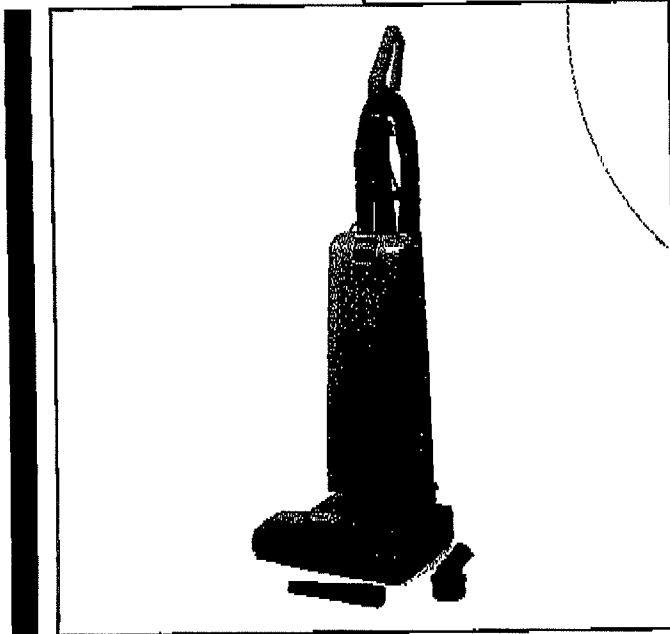

with Bruce  
SOLD 14

new style

**BETCO**

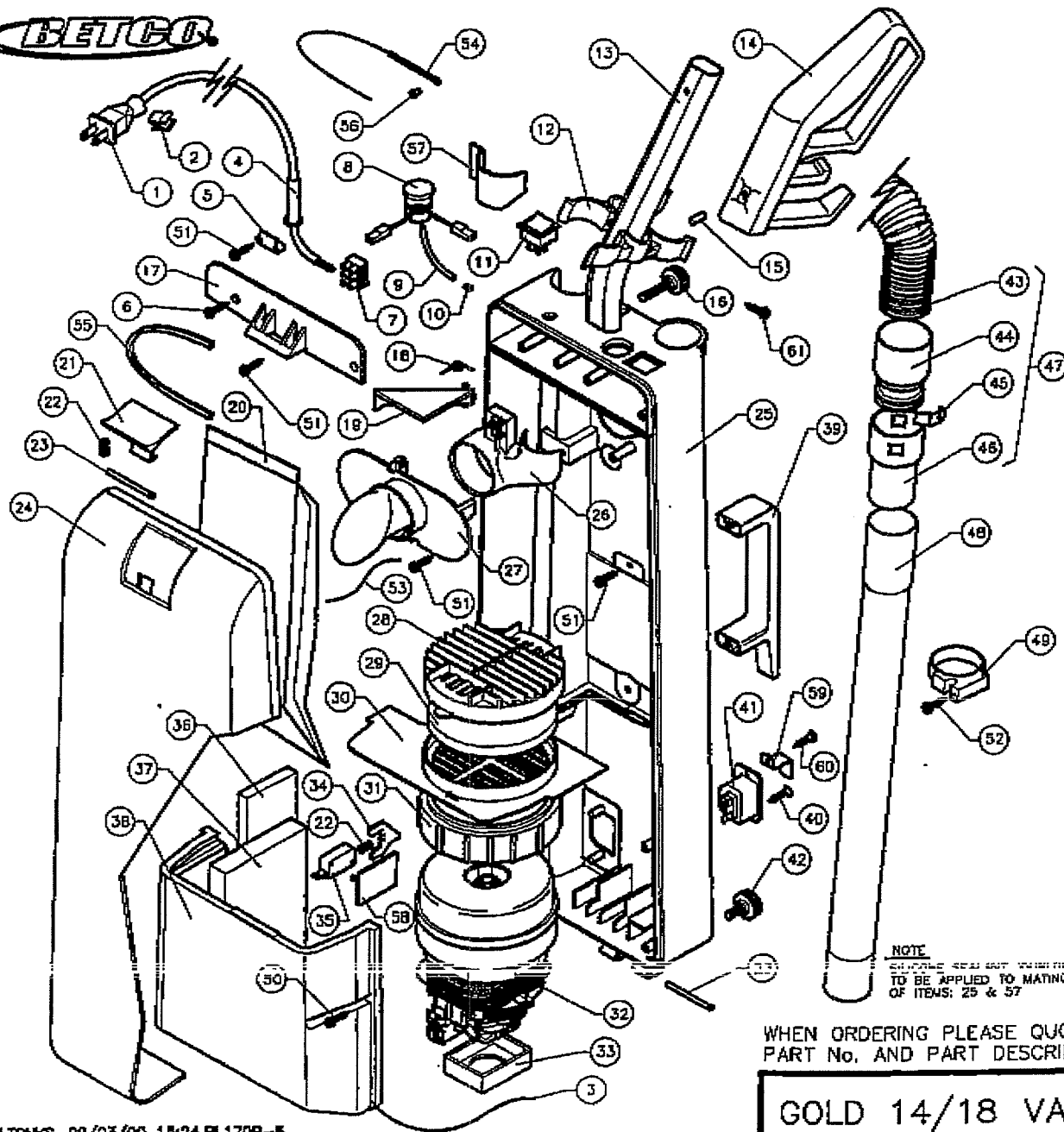

ITEM	PART No.	QTY.	DESCRIPTION
1	85820	1	MAINS LEAD 50' (1mm/2CORE)
2	85821	1	CABLE TIDY
3	85822	—	3mm EXPANDED CORD SEAL
4	85823	1	CABLE GROMMET
5	85824	1	CABLE GRIP
6	85825	2	SCREW C/S 4 x 20mm SPAX
7	85826	1	3-WAY TERMINAL BLOCK
8	85827	1	BAG FULL INDICATOR
9	85828	1	INDICATOR TUBE
10	85829	1	BRASS EYELET
11	85830	1	ON/OFF SWITCH
12	85831	2	TOOL CLIP
13	85832	1	HANDLE TUBE
14	85833	1	PLASTIC HANDLE
15	85834	1	M6x10 SOCKET CRUB SCREW DDD POINT
16	85835	1	M6x30 PLASTIC KNOB
17	85836	1	CATCH PLATE
18	85837	1	ARM SPRING
19	85838	1	NO BAG INDICATOR ARM (RED)
20	85839	1	PAPER DUST BAG
21	85839	1	CATCH
22	85840	2	SPRING
23	85841	3	HINGE PIN
24	85842	1	FRONT CASING (RED)
25	85843	1	REAR CASING
26	85844	1	INLET ADAPTOR
27	85845	1	BAG INLET
28	85846	1	FILTER COVER
29	85847	1	FILTER (BAG BURST)
30	85848	1	MOTOR MOUNTING PLATE
31	85849	1	RUBBER MOTOR RING
32	86053	1	VAC MOTOR 110V
33	85851	1	MOTOR MOUNTING PAD
34	86085	1	MICRO SWITCH PLUNGER
35	85853	1	MICRO SWITCH
36	85854	1	EXIT FILTER
37	85855	1	BAFFLE FDM
38	85856	1	MOTOR COVER
39	85857	1	REAR HANDLE
40	85858	1	SCREW C/S 3 x 12mm SPAX
41	85859	1	SOCKET OUTLET (2 PIN)
42	85860	2	M5 x 10 PLASTIC KNOB
43	85861	1	STRETCH HOSE (330mm)
44	85862	2	SWIVEL END INNER
45	85863	4	RETAINING CLIP
46	85864	2	SWIVEL END OUTER
47	85865	2	32mm SWIVEL HOSE ASSY
48	85866	1	PLASTIC TUBE
49	86066	1	SUCTION TUBE RETAINER
50	85868	4	SCREW PH 4 x 35mm SPAX
51	85869	6	SCREW PH 4 x 20mm SPAX
52	85870	1	SCREW PH 4 x 12mm SPAX
53	85871	1	300mm NYLON CORD
54	85872	1	ANTI-STATIC RESISTOR ASSY
55	85873	1	INLET NOZZLE DUST SEAL
56	85874	1	BRASS EYELET
57	85875	1	ANTI-STATIC LEAD COVER
58	85876	1	MICRO SWITCH PLATE
59	86051	1	PLUG RETAINING BRACKET
60	86052	1	SCREW PH 3 x 12mm SPAX
61	86053	2	SCREW PH R66 x 1" AB POINT S/TAP

WHEN ORDERING PLEASE QUOTE  
PART No. AND PART DESCRIPTION

GOLD 14/18 VACUUM UNIT 115v — BETCO

New Style

Drive Belts old # 85818  
NEW # 86060

**BETCO**

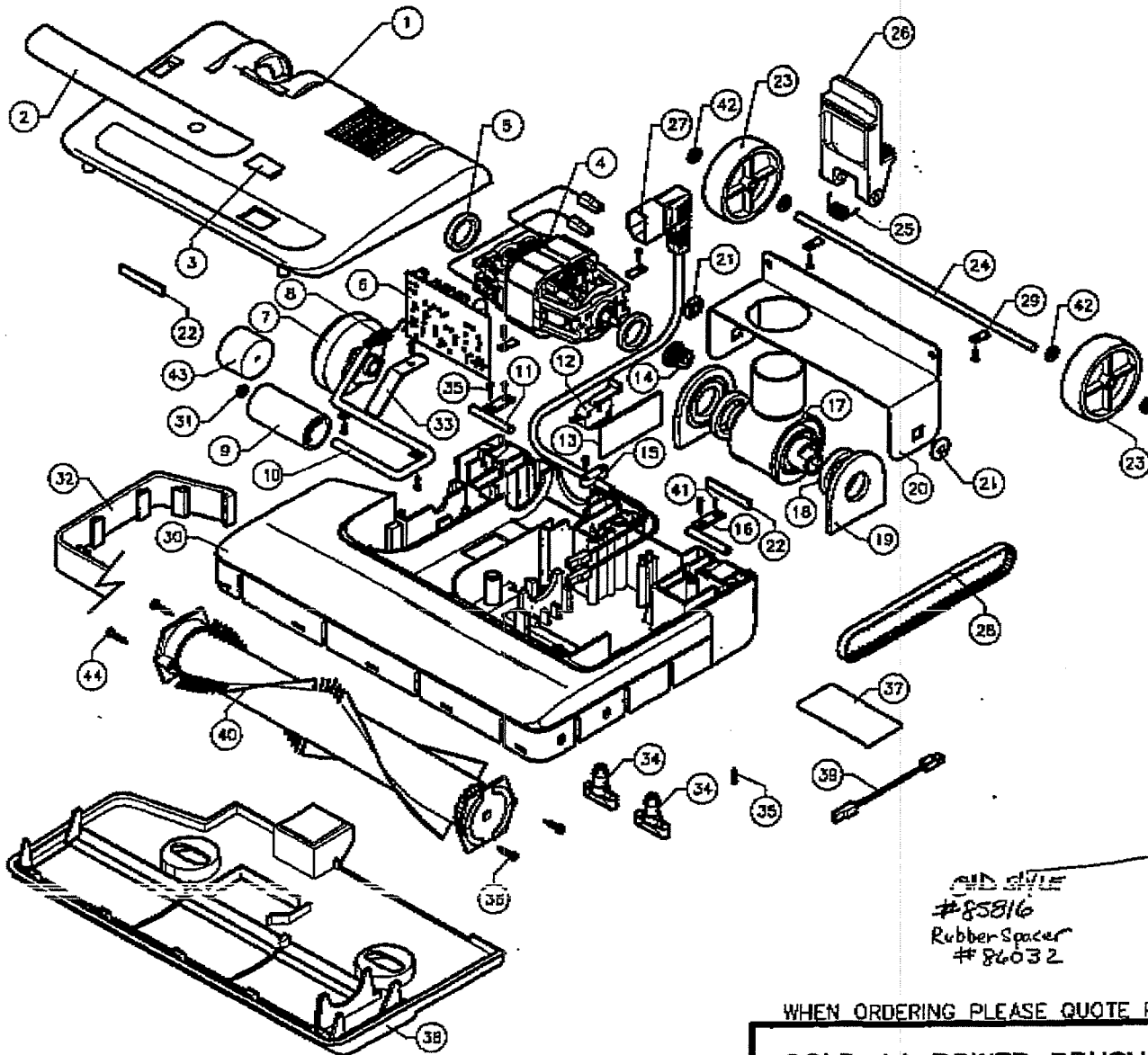

ITEM	PART No.	QTY.	DESCRIPTION
1	85877	1	POWER BRUSH TOP MOULDING
2	86042	1	TOP COVER 14 LABEL
3	85879	1	CLIP IN LENS
4	85880	1	110V 50 Hz 300W MOTOR
5	85881	2	MOTOR SUPPORT RING
6	85882	1	CIRCUIT BOARD - 110V
7	85883	1	HEIGHT ADJUSTMENT KNOB
8	86047	1	ROLLER ADJUSTMENT SPRING
9	85884	1	FLOOR ROLLER
10	85885	1	ROLLER AXLE
11	85886	2	PIVOT PIN
12	85887	1	MICRO SWITCH
13	85888	1	SWITCH PLATE
14	85889	1	COGGED DRIVE (MOTOR END)
15	85890	1	CABLE GRIP
16	85891	2	CLAMP PLATE
17	85892	1	TRUNNION
18	85893	2	TRUNNION SIDE FELT
19	85894	2	TRUNNION SIDE PLATE
20	85895	1	PRESS STEEL BRACKET
21	85896	2	SQUARE BUSH
22	85897	2	FELT SEAL
23	85898	2	WHEEL #66
24	85899	1	WHEEL AXLE
25	86025	1	PARK RELEASE SPRING
26	86026	1	FOOT PEDAL
27	86027	1	INPUT POWER CORD
28	85818	1	DRIVE BELT(XL 128)
29	86028	5	CLAMP WASHER
30	86048	1	POWER BRUSH MIDDLE MOULDING
31	86030	1	6mm STARLOCK CAP
32	86043	1	SMALL BUFFER
33	86064	1	MOTOR FIXING BRACKET
34	86033	2	TURNBUTTON
35	86034	15	M4 x 20mm SPAX
36	86061	1	SCREW C/S 4 x 11mm SPAX
37		1	RATING LABEL
38	86044	1	370 BOTTOM FLOOR PLATE
39	86038	1	INTER CABLE (SWITCH TO PCB)
40	86063	1	370 BRUSH ROLL COMPLETE
41	86039	2	M4 X 12mm SPAX
42	86040	*	NO WASHER
43	86041	1	FOAM RING SEAL
44	86059	2	SCREW C/S 4 x 18mm SPAX

old style  
#85818  
Rubber Spacer  
#86032

WIRING DIAGRAM - 86049

WHEN ORDERING PLEASE QUOTE PART No. AND PART DESCRIPTION

COLD 14 POWER BRUSH ASSEMBLY 115V 60Hz - BETCO