



## Electronic Service Manuals

This electronic document is provided as a service to our customers. We do not create the contents of the information contained in this document. Should you have detailed questions pertaining to the information contained in this document, you may contact Michco, or the manufacturer which provided the original information in this electronic deliverable. Michco's only part in this electronic deliverable was the electronic assembly process. By providing this manual on line we are not guaranteeing parts availability.

You may contact Michco through the following methods:

Phone (517) 484-9312 or (800) 331-3339

2011 N. High St. -- Lansing, Michigan -- 48906

Fax: (517) 484-9836

Email: [CustServe@Michco.com](mailto:CustServe@Michco.com)

Web site: [www.Michco.Com](http://www.Michco.Com)

Parts Web site: [www.FloorMachineParts.Com](http://www.FloorMachineParts.Com)

Order Parts on Line at:

**[www.FloorMachineParts.Com](http://www.FloorMachineParts.Com)**

Directly to Parts & Service:

By Email: **[Shop@Michco.com](mailto:Shop@Michco.com)**

By Fax: (517) 702-2041

By Voice: Use numbers above.

**Serving the Cleaning Industry Since 1922**

Notice: All copyrighted material remains property of original owners, all trademarks are property of respective owners. Manuals are subject to Manufacturer's reproduction limitations. Originals or reproductions were provided by manufacturers through a request. We make no warranty as to the correctness of information provided in this document and you assume all risk. By placing these manuals on line we are not declaring our corporation to be an manufacturer authorized dealer or provider, please check our web site for authorized manufacturers we represent.

# Heavy Duty Floor Machines

## Operator's Manual



**CREWMAN™ 20 HD Item #83014-00**  
**CREWMAN™ 17 HD Item #83013-00**  
**FOREMAN™ 20 HD Item #85021-00**  
**FOREMAN™ 17 HD Item #85028-00**  
**FOREMAN™ 20 DS Item #83010-00**  
**FOREMAN™ 17 DS Item #83009-00**

*Chemicals*  
*Equipment*  
*Programs*  
*Process*

**BETCO®**



## **Specifications**

- **Cleaning Path/Pad Size:** 17", 20"
  - **Hour Meter:** Yes / 0.1 hour resolution
  - **Motor:** 1.5 hp, 120v, 12 A, 60 HZ
  - **Pad Speed:** 175 RPM
  - **Power Cord:** 50' 14/3 Safety Yellow
  - **Handle Grips:** Anti-Fatigue
  - **Operating Wheels:** 5" Non-marking
  - **Productivity:** Bonnet-1100 sq.ft/hr., buff/scrub-2400 sq.ft/hr., strip-800 sq.ft/hr.
  - **Weight:** 90 lbs.
  - **Dimensions:** Length 24.25", Width 20", Height 48"
- 

## **! WARNING! IMPORTANT SAFETY INSTRUCTIONS**

**Carefully read and understand this manual before operating this machine.**

**To reduce risk of fire, electric shock, or injury:**

- Do not operate in explosive areas, near flammable liquids or gases.
- Only plug into a properly grounded outlet.
- Do not exposure to rain, store indoors.
- Do not plug in or handle machine with wet hands.
- Do not operate the machine with a damaged cord or plug.
- Do not block or disconnect safety lever.
- Do not leave machine plugged in while unattended.
- Unplug machine before servicing.
- Do not put fingers under the pad or pad holder.
- Unplug the machine before installing or removing the pad.
- Use only high speed burnishing pads.
- Do not put any foreign object into openings. Do not use with any opening blocked; keep free of dust, lint, hair, & anything that may reduce airflow.
- Keep hair, loose clothing, fingers, & all parts of body away from openings & moving parts.
- Turn off all controls before unplugging.
- Do not use in or around flammable or combustible liquids such as gasoline or use in areas where they may be present.
- Connect to a properly grounded outlet only. See grounding instructions.

## **Grounding Instructions**

This machine must be grounded. If it should electrically malfunction, grounding provides a path of least resistance for electric current to reduce the risk of electric shock. This machine is equipped with a cord having an equipment-grounding conductor & grounding plug. The plug must be plugged into an appropriate outlet that is properly installed & grounded in accordance with all local codes & ordinances.

### **! DANGER!**

Improper connection of the equipment-grounding conductor can result in a risk of electric shock. Check with a qualified electrician or service person if you are in doubt as to whether the outlet is properly grounded. Do not modify the plug provided with the machine. If plug will not fit the outlet, have a proper outlet installed by a qualified electrician.

Replace the plug if the grounding pin is damaged or broken.

Extension cords connected to this machine should be 12 gauge, 3-wire cords with 3-prong plugs & outlets. DO NOT use extension cords more than 50 feet long.

---

## **Operating Instructions**

**Check machine for damage to cord or plug.**

**Use suitable pads or brushes.**

**To install or change the pad:**

1. Unplug the machine.
2. Tip the machine back on the wheels.
3. Install pad driver or brush.
4. Center the pad on the pad driver.

**To operate the machine:**

1. Plug into a grounded outlet.
  2. Release the handle and lower it.
  3. The handle can be locked into a comfortable position for the operator or used free floating.
  4. Press the safety lever and squeeze the trigger to start the machine.
  5. Do not operate in one place as damage to the floor or finish could result.
  6. Do not operate the machine with the handle in the upright position.
  7. Remove the pad after every use.
  8. Store the machine tilted back on the transport wheels.
  9. Use only new or clean pads and reverse them as needed.
- 

## **Maintenance Instructions**

To maintain appearance – wipe the machine with a damp cloth after use.

**Warning** – Unplug the machine before servicing

This machine is equipped with an hour meter to signal maintenance intervals of 250 hours. It will begin flashing at 245 hrs and stop at 255 hrs to signal the operator to check the following:

1. Check the motor brushes for wear or excessive arcing.
2. Check the cord and electrical system.
3. Check the safety lockout on the trigger.
4. Check wheels.

# HANDLE PARTS

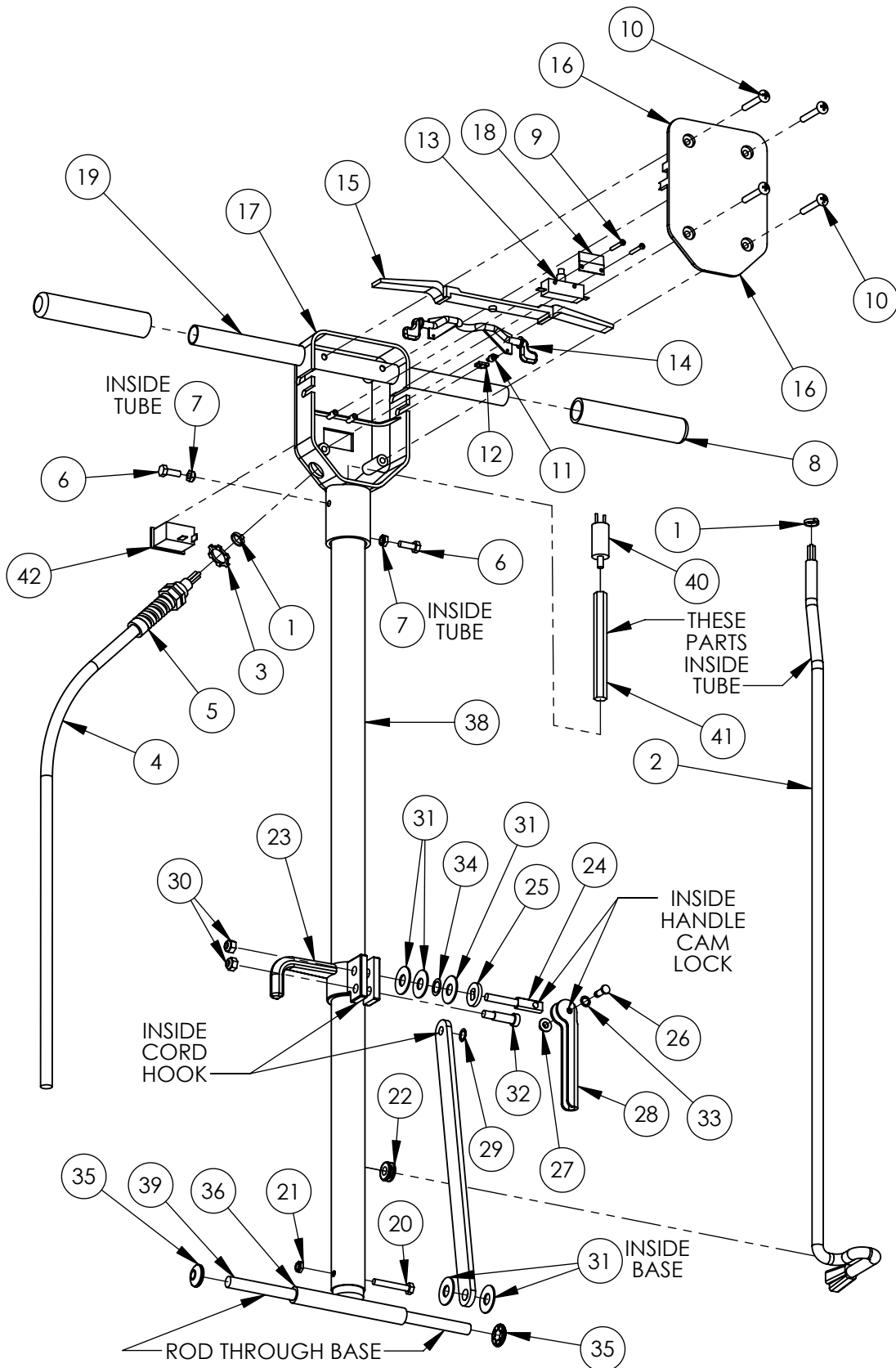

# HANDLE PARTS

ITEM NO.	BETCO PART #	DESCRIPTION	QTY.
1	E283523	NYLON CABLE TIE	2
2	E283132	CORD, HANDLE, 14-3	1
3	E283789	NUT, ELECTRICAL CONDUIT, 1/2"	1
4	E283131	CORD, 75 FEET, 14-3 ST	1
5	E283496	STRAIN RELIEF FOR REPLACEMENT	1
6	E281064	BOLT, HEX, 1/4-20 x 3/4	2
7	E283520	NUT, NYLOCK, 1/4-20	2
8	E283127	GRIP	2
9	E283427	SCREW, PHILLIPS, No. 6 x 1	2
10	E283426	SCREW, PHILLIPS, 1/4-20 x 1.75	4
11	E283130	SPRING	1
12	E283270	CLIP, SPRING	1
13	E285032	SWITCH	1
14	E283129	SAFETY LOCK	1
15	E282752	TRIGGER, SWITCH	1
16	E283325	COVER, SWITCH BOX	1
17	E283125	SWITCH BOX, HANDLE, DUAL SPEED	1
18	E281105	PLATE, SWITCH	1
19	E283451	HANDLE TUBE, 7/8 x 16	1
20	E281065	BOLT, HEX, 1/4-20 x 1-3/4, GRADE 5	1
21	E281070	NUT, NYLOCK, 1/4-20	1
22	E283519	GROMMET, .375 ID	1
23	E283137	CORD HOOK	1
24	E283134	BOLT, ADJUSTABLE, CAM, 5/16-18	1
25	E283135	OVAL WASHER	1
26	E283266	PIN, .25 x .75	1
27	E283268	CAP, PUSH, .25	1
28	E283133	HANDLE, CAM LOCK	1
29	E281379	WASHER, SPRING, 3/8	1
30	E281063	NUT, NYLOK, 5/16-18	2
31	E283145	WASHER, NYLON	5
32	E281077	BOLT, SHOULDER, 3/8 x 1	1
33	E283267	WASHER, SPRING, 1/4	1
34	E283269	WASHER, SPRING, 1/2	1
35	E283143	CAPS, AXLE, 0.5	2
36	E282729	HANDLE ATTACHMENT, WELDED "T"	1
37	E283136	BRACKET, FLAT, HANDLE	1
38	E283711	HANDLE TUBE	1
39	E283452	AXLE, 1/2 x 12.375	1
40	E283662	SPEED CONTROL, DUAL SPEED MACHINE	1
41	E283652	HEAT SINK ROD	1
42	E283608	SWITCH, ROCKER, 2 SPEED	1

**NOTE:**  
**DUAL SPEED FLOOR MACHINE HAS ALL PARTS LISTED.**  
**SINGLE SPEED MACHINE DOES NOT HAVE PARTS 40, 41, AND 42.**

# BASE, MOTOR, AND WHEELS

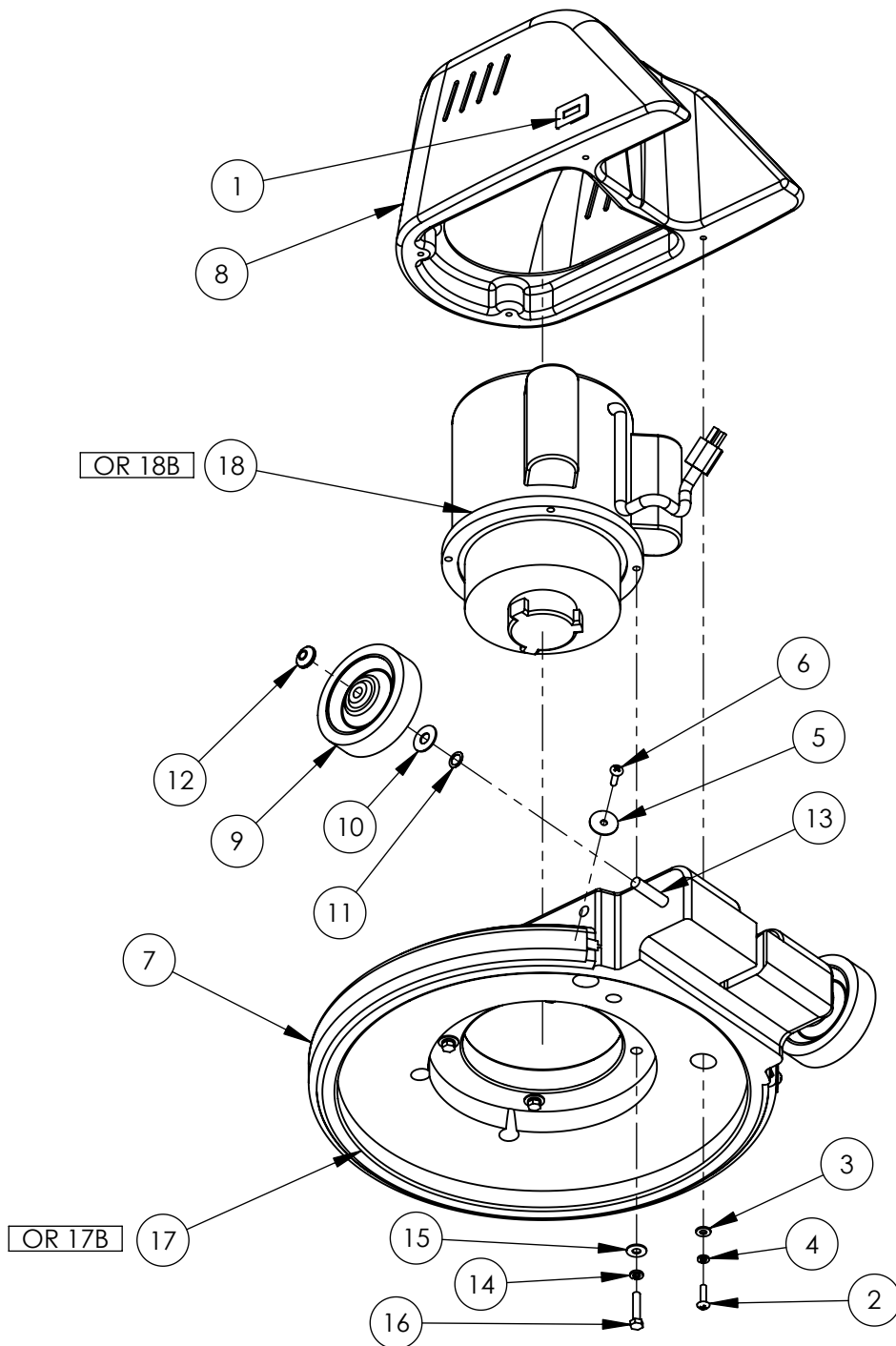

# BASE, MOTOR, AND WHEELS

ITEM NO.	BETCO PART #	DESCRIPTION	QTY.
1	E283147	HOUR METER	1
2	E283570	SCREW, PHILLIPS, 1/4-20 x 1	4
3	E489334	WASHER, FLAT, 1/4	4
4	E281078	WASHER, LOCK, 1/4	4
5	E281068	WASHER, FENDER, 1/4	2
6	E283425	SCREW, PHILLIPS, 1/4-20 x 1	2
7	E283141	BUMPER	1
8	E281397	COVER, MOTOR, BURGANDY, LOW SPEED	1
9	E283144	WHEEL, 5 INCH	2
10	E283145	WASHER, NYLON	2
11	E283269	WASHER, SPRING, 1/2	2
12	E283143	CAPS, AXLE, 0.5	2
13	E283379	AXLE, 1/2 x 13.875	1
14	E281067	WASHER, LOCK, 5/16	4
15	E281062	WASHER, FLAT, USS, 5/16	4
16	E283641	BOLT, HEX, 5/16-18 x 1.5	4
17	E281129	BASE, 20 INCH, LOW SPEED	1
18	E283191	MOTOR, 1.5 HP, AC	1
17B	E281127	BASE, 17 INCH, LOW SPEED	1
18B	E281106	MOTOR, 1.5 HP, DUAL SPEED	1

# MOTOR COVERS

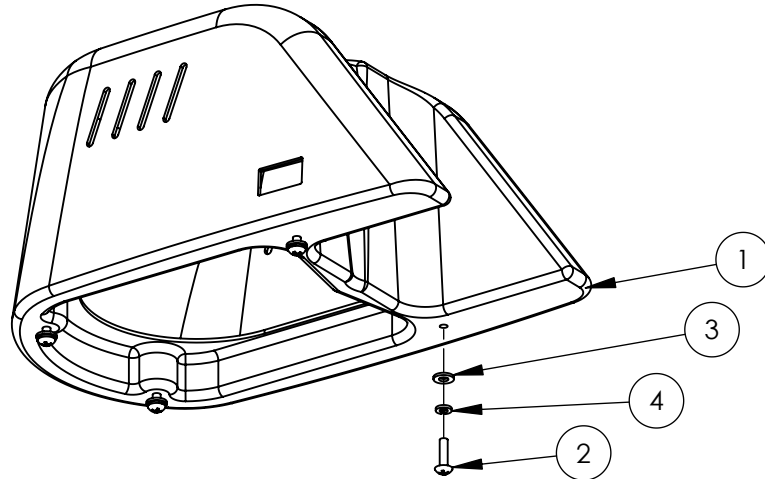

ITEM NO.	BETCO PART #	DESCRIPTION	QTY.
1	E283642	COVER, MOTOR, RED, LOW SPEED	1
2	E283570	SCREW, PHILLIPS, 1/4-20 x 1	4
3	E489334	WASHER, FLAT, 1/4	4
4	E281078	WASHER, LOCK, 1/4	4

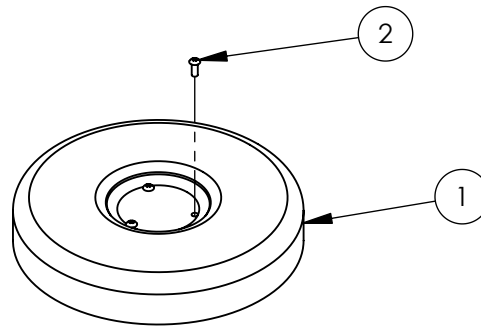

ITEM NO.	BETCO PART #	DESCRIPTION	QTY.
1	E281140	COVER, MOTOR, 9" OD x 1.65 TALL	1
2	E281526	SCREW, PHILLIPS, 10-32 x .5 TRUSS HEAD	3

# ELECTRICAL

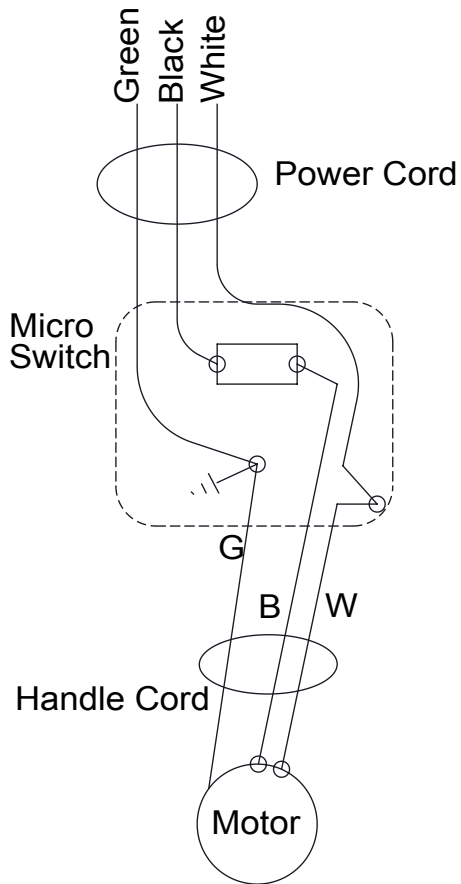

**Standard Machines**

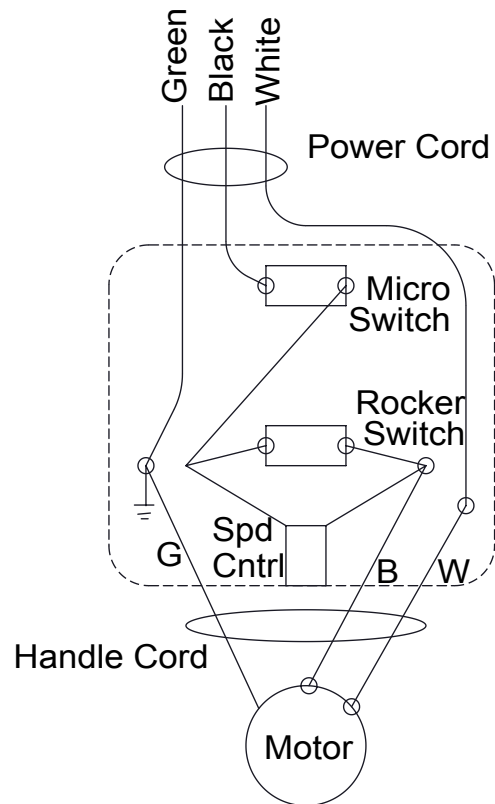

**Two Speed Machines**



## Betco Warranty Express Program™ Revised November 1, 2006

### **10 Year Coverage**

Subject to the conditions stated below, Betco Corporation warrants parts and labor on rotationally molded polyethylene tanks/housings and injection molded vacuum head assemblies to be free from defects in materials and workmanship for a period of ten years to the original purchaser.

### **3 Year Coverage**

Subject to the conditions stated below, Betco Corporation warrants parts and labor on all other Betco components to be free from defects in materials and workmanship for a period of three years to the original purchaser.

### **1 Year Coverage**

Subject to the conditions stated below, Betco Corporation offers a limited warranty on parts and labor on the following equipment, parts and accessories to be free from defects in material and workmanship for a period of one year to the original purchaser.

- DM Series Vacuums:  
#85506-00, #85507-00
- Bac Pac Lite Vacuum:  
#85903-00
- FiberPRO® Floor Dryer:  
#85507-00
- WORKMAN™ Series Vacuums:  
#85024-00, #85025-00,  
#85026-00, #85027-00
- CV100T Vacuum:  
#85023-00
- All Tools and Accessories
- All Battery Chargers
- All Batteries are pro-rated for 1 year.

### **Allowable Travel Time Warranty Reimbursement:**

Eligible equipment: All battery and propane powered equipment products.

Warranty period: 90 days from date of sale to the original purchaser. A maximum 60 mile round trip at 44 cents per mile will be allowed for warranty consideration.

### **Propane Machine Warranty:**

Honda engines are warranted by Honda for a period of 2 years against manufacturer defect. Kawasaki engines are warranted by Kawasaki for a period of 2 years against manufacturer defect. All other components (except wear items)\* are warranted by Betco Corporation for a period of 3 years.

### **\*Wear items exempt from warranty consideration include but may not be limited to: power cords, transport wheels, vacuum bags, belts, squeegee blades, pad drivers, clutch plates, handle grips, filters, screens, throttle cables, brushes and carbon brushes.**

Subject to the conditions and exceptions stated in this warranty, Betco warrants the Betco products to be free from defects in material and workmanship, under normal use and service, for the periods listed under the warranty policy to the original purchaser. At any time during the warranty period, Betco will furnish replacement parts for the Betco products to the original purchaser. Such parts will be furnished and charged including transportation costs, to the original owner through any Betco authorized Service Distributor. If the original part is returned within the warranty policy period from date of delivery for inspection by Betco and is found to be defective, the owner will be credited for the cost of replacement parts plus shipping and handling. Replacement parts that have become defective through wear or abuse are not included in this warranty.

This warranty does not apply to damage or defect caused by accident, misuse, negligence, fire or to any Betco product which has been serviced or repaired by other than an authorized Betco Service Distributor or Betco factory personnel. This warranty is void if products are used for any purpose other than that which was intended. There are no other warranties expressed or implied. In no event shall Betco be liable for incidental or consequential damages or any damage to person or property. (Please note some states do not allow the exclusion or limitations for incidental and consequential damages.)