



## Electronic Service Manuals

This electronic document is provided as a service to our customers. We do not create the contents of the information contained in this document. Should you have detailed questions pertaining to the information contained in this document, you may contact Michco, or the manufacturer which provided the original information in this electronic deliverable. Michco's only part in this electronic deliverable was the electronic assembly process. By providing this manual on line we are not guaranteeing parts availability.

You may contact Michco through the following methods:

Phone (517) 484-9312 or (800) 331-3339

2011 N. High St. -- Lansing, Michigan -- 48906

Fax: (517) 484-9836

Email: [CustServe@Michco.com](mailto:CustServe@Michco.com)

Web site: [www.Michco.Com](http://www.Michco.Com)

Parts Web site: [www.FloorMachineParts.Com](http://www.FloorMachineParts.Com)

Order Parts on Line at:

**[www.FloorMachineParts.Com](http://www.FloorMachineParts.Com)**

Directly to Parts & Service:

By Email: **[Shop@Michco.com](mailto:Shop@Michco.com)**

By Fax: (517) 702-2041

By Voice: Use numbers above.

**Serving the Cleaning Industry Since 1922**

Notice: All copyrighted material remains property of original owners, all trademarks are property of respective owners. Manuals are subject to Manufacturer's reproduction limitations. Originals or reproductions were provided by manufacturers through a request. We make no warranty as to the correctness of information provided in this document and you assume all risk. By placing these manuals on line we are not declaring our corporation to be an manufacturer authorized dealer or provider, please check our web site for authorized manufacturers we represent.

# Watchman™ 20 Operator's Manual

## Operator's Manual

Item #86008



Better Resources. Better Results.  
**BETCO**®

©Betco Corporation. All Rights Reserved • 1001 Brown Avenue • P.O. Box 3127 • Toledo, Ohio 43607-0127 • 800-777-9343 • [www.betco.com](http://www.betco.com)

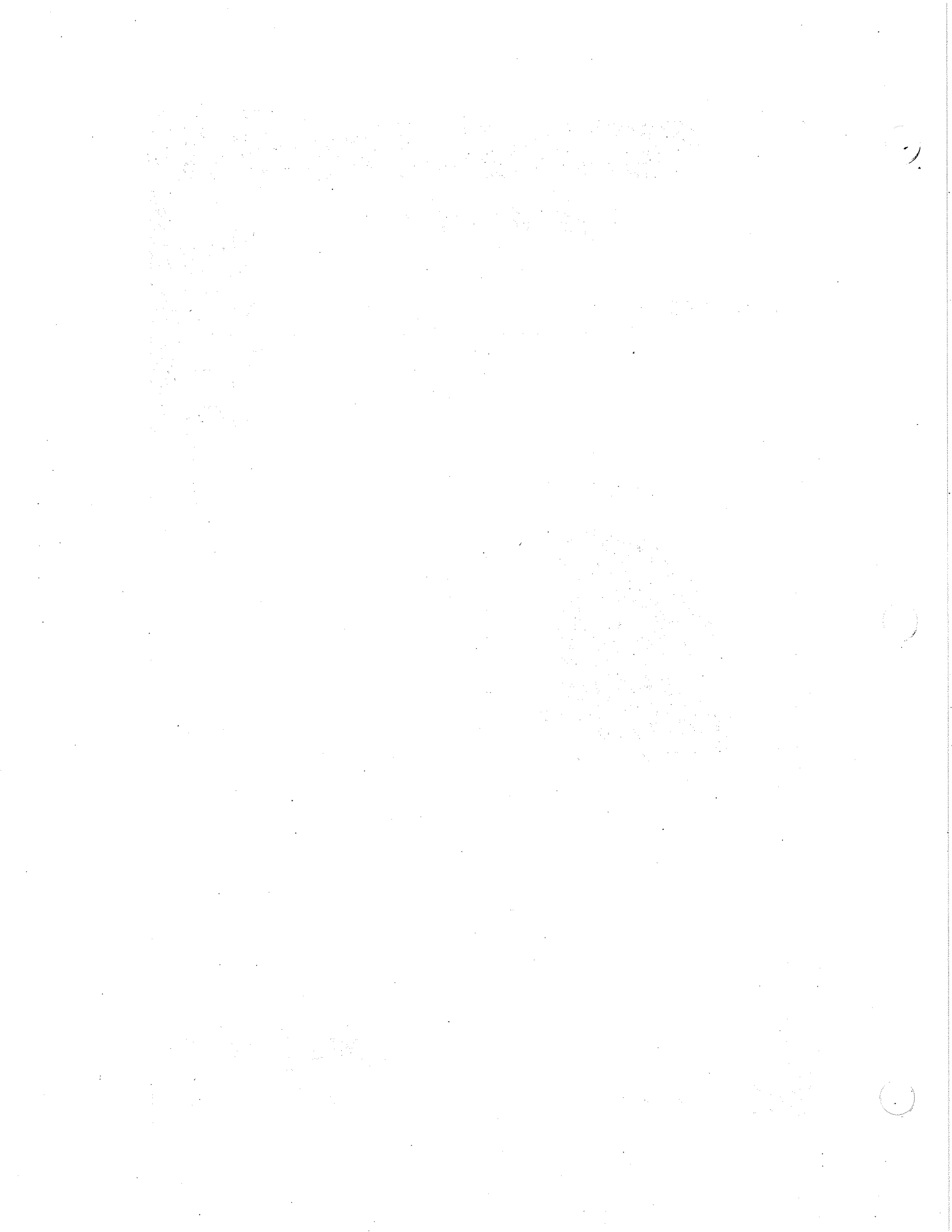

# 1. TABLE OF CONTENTS

1. TABLE OF CONTENTS .....	2
2. GENERAL INFORMATION .....	4
2.1. SCOPE OF THE MANUAL .....	4
2.2. IDENTIFICATION OF THE MACHINE .....	5
2.3. DOCUMENTATION ANNEXED TO THE MACHINE .....	5
3. TECHNICAL INFORMATION .....	6
3.1. GENERAL DESCRIPTION .....	6
3.2. LEGEND .....	6
3.3. OVERALL DIMENSIONS .....	7
3.4. TECHNICAL SPECIFICATIONS .....	8
3.5. DANGER AREAS .....	8
3.6. ACCESSORIES .....	9
4. INFORMATION ON SAFETY .....	9
4.1. SAFETY STANDARDS .....	9
5. HANDLING AND INSTALLATION .....	12
5.1. LIFTING AND CARRYING THE PACKED MACHINE .....	12
5.2. CHECKING THE MACHINE ON DELIVERY .....	12
5.3. UNPACKING .....	12
5.4. FEEDING BATTERIES .....	13
5.4.1. Batteries: preparation .....	14
5.4.2. Batteries: installation and connection .....	14
5.5. THE BATTERY-CHARGER .....	15
5.5.1. Choosing the battery-charger .....	15
5.5.2. Preparing the battery-charger .....	15
5.6. LIFTING AND HANDLING THE MACHINE .....	16
6. PRACTICAL GUIDE FOR THE USER .....	16
6.1. CONTROL DEVICES - DESCRIPTION .....	16
6.2. INSTALLING AND ADJUSTING THE SQUEEGEE .....	17
6.3. MOVING THE MACHINE .....	18
6.4. INSTALLING AND REPLACING THE BRUSH / DRIVE DISC .....	18
6.5. DETERGENTS - Use .....	19
6.6. SETTING UP THE MACHINE .....	19
6.7. WORK .....	21
6.8. SOME USEFUL SUGGESTIONS FOR THE OPTIMAL USE OF THE MACHINE .....	22
6.8.1. Pre-washing .....	22
6.8.2. Drying .....	22
6.9. DRAINING OFF DIRTY WATER .....	22
6.10. DRAINING OFF CLEAN WATER .....	24
7. PERIODS OF INACTIVITY .....	25
8. MAINTENANCE AND BATTERY RECHARGING .....	25
8.1. RECHARGING PROCEDURES .....	23

**9. INSTRUCTIONS FOR MAINTENANCE..... 26**  
9.1. MAINTENANCE – GENERAL RULES ..... 24  
9.2. ROUTINE MAINTENANCE ..... 26  
    9.2.1. *Daily cleaning* ..... 26  
    9.2.2. *Suction air filter and floating rod: cleaning*..... 28  
    9.2.3. *Squeegee blades: replacement*..... 28  
    9.2.4. *Fuses: replacement*..... 29  
9.3. PERIODIC MAINTENANCE ..... 30  
    9.3.1. *Daily maintenance* ..... 30  
    9.3.2. *Weekly maintenance* ..... 30  
    9.3.3. *Six-monthly maintenance* ..... 30  
**10. HOW TO ORDER SPARE PARTS ..... 31**  
**11. TROUBLESHOOTING ..... 32**  
11.1. HOW TO OVERCOME POSSIBLE FAILURES ..... 32

## 2. GENERAL INFORMATION



Read this manual carefully before starting any operations on this machine<sup>1</sup>.

### 2.1. Scope of the manual

This manual has been drawn up by the Manufacturer and is considered as an integral part of the machine.

It defines the purpose for which the machine has been manufactured and contains all information the operators<sup>2</sup> require.

Besides this manual, which contains the necessary information for the users, other publications have been issued, which contain the specific information for the technicians in charge of maintenance<sup>3</sup>.

The constant observance of the instructions guarantee the safety of man and machine, low running costs, quality results and a longer work life of the machine itself. The non-observance of the prescribed rules could injure men, damage the machine, spoil the washed floor and even the environment.

To find the single topics in a fast way, see the descriptive table of contents at the beginning of this manual.

The paragraphs that are not to be neglected are printed in bold letters and preceded by symbols illustrated and defined below.

### ! DANGER

Indicates that attention must be paid to avoid serious consequences that could cause the death of the personnel or possible damages to health.

### ⚠ WARNING

Indicates that attention must be paid to avoid serious consequences that could damage the machine, spoil the environment where the machine is used or cause economic losses.

### i INFORMATION

Particularly important instructions.

In following a policy of constant development and update of the product, the Manufacturer could implement modifications without any previous notice.

Even though the machine you own is greatly different from the one(s) illustrated in this manual, safety and information thereof are guaranteed anyway.

<sup>1</sup> The definition "machine" substitutes the commercial name to which this manual refers.

<sup>2</sup> People authorised to use the machine without carrying out maintenance operations that require precise technical knowledge.

<sup>3</sup> People having the experience, technical preparation and knowledge of the regulations and laws necessary to carry out the activity and capable to recognize and avoid possible dangers when handling, installing, using the machine and carrying out maintenance operations.

## 2.2. Identification of the machine

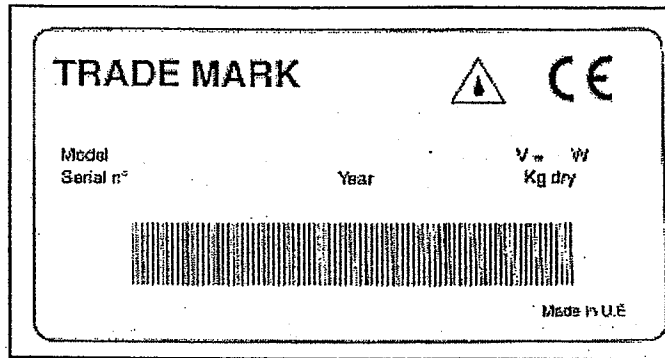

**Fig. 1**

The number plate (fig. 1), which is attached at the rear of the machine, shows the following information:

- model code;
- machine model;
- power supply voltage;
- total rated power;
- serial number (registration number);
- year of manufacture;
- dry weight;
- maximum full load weight;
- steepest slope that can be overcome;
- bar code with serial number;
- Manufacturer's identification.

## 2.3. Documentation annexed to the machine

- User's Manual;
- warranty certificate;
- adhesive slips for spare part orders;
- test sheet;
- CE Certificate of conformity.

### 3. TECHNICAL INFORMATION

#### 3.1 General description

The machine is a sweeping scrubber, which can be used in civil and industrial environments for sweeping, washing and drying flat, horizontal, smooth or moderately rough floors, with even surfaces and free from obstacles. It is available either in the version with battery or with cable to meet with any requirements of autonomy and weight. The scrubber distributes on the floor an adequately dosed solution of water and detergent, and brushes it to remove dirt. Choosing with care the right cleaning detergent and brush (or abrasive disc) in the wide range of accessories available, the machine can adapt itself to all kinds of combinations of floors and dirt.

A liquid suction system, which is embedded in the machine, allows a perfect drying of the just-washed floor: actually thanks to a suction unit which sucks up the air from the recovery tank thus creating a vacuum, the squeegee scrapes the dirty water from the floor, collects it and sends it to the recovery tank.

#### 3.2. Legend

The main components of the machine are the following (fig. 2):

- the detergent solution tank (fig. 2, ref. 7): used to contain and carry the mixture of clean water and detergent;
- the recovery tank (fig. 2, ref. 2): used to collect dirty water sucked up from the floor during washing;
- control panel (fig. 2, ref. 1);
- head unit (fig. 2, ref. 4): the main element is represented by the brush (fig. 2, ref. 5), which distributes the detergent solution on the floor, removing dirt;
- squeegee unit (or floor wiper, fig. 2, ref. 6): used to wipe and dry the floor, sucking up the water spread on the floor;
- small carriage wheel (fig. 2, ref. 3): makes the machine displacements easier when the brush motor is off.

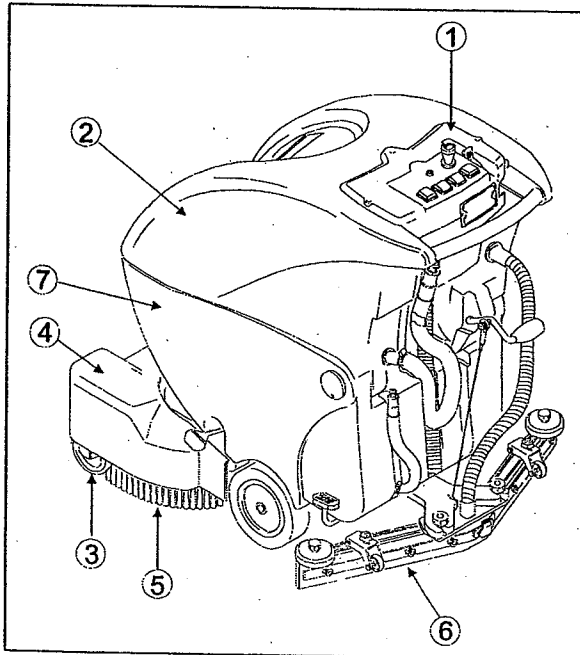
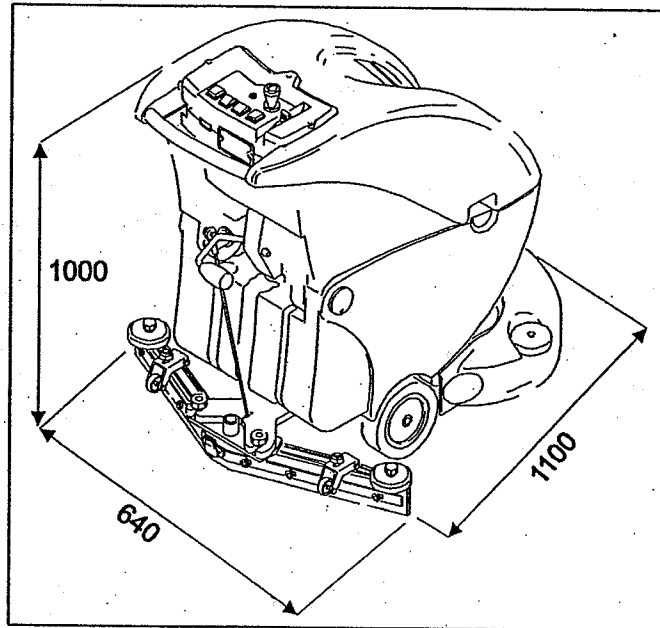

Fig. 2

### 3.3 Overall dimensions



### 3.4. Technical specifications

Cleaned track width	mm	540
Squeegee width	mm	800
Hourly performance	m <sup>2</sup> /h	1850
Number of brushes	n°	1
Brush diameter	mm	530
Max brush pressure	daN	44
Brush rotation speed	g/1°	135
Brush motor power	W	600
Drive control	/	mechanical
Maximum speed	Km/h	3,5
Three-stage suction motor power	W	550
Suction motor vacuum	Pa	17000
Noise level	dB(a)	66
Solution tank	l	50
Recovery tank	l	60
Wheel diameter	mm	200
Net weight without batteries	Kg	63
Number of batteries	n°	2
Series battery voltage	V	24
Single battery capacity	Ah (5h) Ah (20h)	110 140
Single battery weight	Kg	36
Power supply cable length	mm	/
Power supply voltage	V	/
Power supply frequency	Hz	/
Battery compartment size (length, width, height)	mm	380x 360x 300
Machine size (length, width, height)	mm	1100x 640x 1000
Dimensions of packing (length, width, height)	mm	1130x 680x 1180

**Table A** Data can be changed without notice.

### 3.5. Danger areas

**A -Tank unit:** in presence of certain detergents, danger of irritation for the eyes, skin, mucous diaphragms, respiratory apparatus and asphyxia. Danger caused by dirt recovered from the environment (germs and chemical substances). Danger of crushing between the recovery tank and solution tank, when the recovery tank is replaced on the solution tank.

**B -Control panel:** danger of shortcircuits.

**C -Bottom of washing head:** danger caused by the brush rotation.

**D -Rear wheels:** danger of crushing between wheels and chassis.

**E -Battery compartment** (located within the solution tank): danger of short circuits between the battery poles and presence of hydrogen during battery charging.

### 3.6. Accessories

- **Bristle brushes:** used for washing delicate floors and for polishing;
- **Polipropilene brushes:** used for normal floor washing;
- **Tynex brushes:** used to remove accumulated stubborn dirt on resistant floors;
- **Drive discs:** allow the use of the following discs:
  - \* yellow discs: used for washing and polishing marble and similar surfaces;
  - \* green discs: used for washing of resistant floors;
  - \* black discs: used for thorough washing of resistant floors with stubborn dirt;

## 4. INFORMATION ON SAFETY

### 4.1. Safety standards



**Read the User's manual carefully before proceeding with start-up, use, maintenance, routine maintenance or any other operations on the machine.**

### **WARNING**

**Stick to all the instructions contained in this Manual (especially those regarding danger and warning) and observe the safety plates attached on the machine.**

**The Manufacturer declines all responsibility for injures to persons or damage to things deriving from the non-observance of these instructions.**

The machine must be used by trained personnel only, who have shown their skill and have been expressly authorized to use it.

Persons under eighteen cannot use the machine.

This machine must not be used for any other purpose than that for which it has been expressly manufactured. Assess the type of building in which it will be used (e.g. pharmaceutical and chemical companies, hospitals, etc.) and scrupulously respect the regulations and conditions in force.

Do not use the machine in places that are not adequately lighted, in environments with danger of explosions, on public roads, in the presence of dirt harmful to health or improper environments.

The suitable temperature for the use of the machine ranges between +4°C and +35°C; when the machine is not used, the temperature range is between +0°C e +50°C.

The humidity range for the machine under any conditions varies between 30% and 95%.

Never use or suck up inflammable or explosive liquids (e.g. petrol, fuel oil, etc.), inflammable gases, dry dust, acids and solvents (e.g. solvents for paints, acetone, etc.) even if diluted. Never suck up any burning or white-hot objects.

Do not use the machine on slopes or ramps higher than 2%; in the event of light slopes do not use it transversally, handle it with extreme care and do not reverse. When driving along ramps or heavier slopes take great care to avoid overturning or uncontrolled acceleration. Overcome ramps and/or steps exclusively with the brush head and

squeegee lifted.

**Never park the machine on slopes.**

Never leave the machine in operation unattended. Leave the machine only after having switched off the motor, made sure that it cannot move accidentally and unplugged it from the mains.

When using the machine mind the presence of people particularly children in the environment where you are working.

Do not use the machine to carry persons/things or to tow things. Do not drag the machine.

Never lay things on the machine for any reason.

Do not obstruct the air vents and heat dispersion openings.

Do not remove, modify or elude the safety devices.

Various and unpleasant experiences have shown that people wear or carry various objects capable of causing serious accidents: before starting to work, remove trinkets, watches, neckties or other such things.

Always use individual safety protections: apron or protective suit/overalls, non-slip water-proof shoes, rubber gloves, protective goggles and caps, face mask to protect the respiratory system.

Do not put the hands in between moving organs.

Do not use detergents different from those provided for, and stick to the instructions indicated on the respective safety sheets. Keep detergents in a safe place, inaccessible to children, and in case they come in contact with the eyes, wash them immediately with plenty of water or, if swallowed, call for a doctor immediately.

Make sure that the plugs for the power supply of the models with cable or of the battery-chargers are properly grounded and protected by magnetothermal switches and differentials.

Make sure that the electric characteristics of the machine (voltage, frequency, absorbed power) indicated on the identification plate (fig. 1), are compliant with those of the power distribution plant. The machine with cable is equipped with three lead wires and a three-contact ground plug for the use of a proper grounding plug. The yellow and green wire of the cable is the earth wire: never connect this wire to other wires that are not the plug ground tap.

It is fundamental to observe the battery Manufacturer's instructions and stick to the Legislator's provisions. Keep batteries always dry and clean to avoid surface leakage currents. Keep batteries safe from impurities, for instance metal dust.

Do not lay tools on batteries: danger of short circuits and explosions.

Mind the use of battery acid: stick to the relative safety instructions.

When using the machine model with cable mind that you do not crush or tear the power supply cable. Check this cable periodically to control if it is damaged; if this is so, the machine cannot be used.

In presence of particularly high magnetic fields assess the possible effects on the control electronics.

Never wash the machine with jets of water.

The recycled fluids contain detergents, disinfectants, water, organic and inorganic stuff recycled during the work stages: they must be disposed of in compliance with the laws in force.

In case of breakdown and/or bad operation of the machine, switch it off immediately (unplugging it from the mains) and do not tamper with it. Contact a technical assistance centre of the Manufacturer's.

All maintenance operations must be performed in adequately lighted environments and only after having disconnected the machine from the power supply (in models with cable by unplugging the machine from the socket, while in models with battery by detaching the battery connector).

Have any electrical work and all maintenance and repair operations (particularly those not explicitly described in this manual) carried out by a specialised and trained technical staff only.

In case of replacement of the power supply cable, plug or terminals, perform the repair by properly fixing the electric connections and the cable blocking strap that is located in the control panel, to guarantee the resistance of the cable. Then reassemble the panel with care to ensure the protection of the machine user.

Only the use of original accessories and spare parts supplied by the Manufacturer is permitted, as only these offer the certainty that the machine will operate safely and without any inconveniences. Do not use parts removed from other machines or other kits as spares.

This machine has been designed and manufactured for a service endurance of ten years starting from the date of manufacture, which can be seen on the identification plate (see fig. 1). After this time, whether the machine has been used or not, disposal must be considered according to the laws in force in the place of use:

- the machine must be disconnected from the mains, emptied of all liquids and cleaned;
- then it must be dismantled in homogeneous groups of materials (plastics according to the indications of the recycling symbol, metals, rubber, wrapping and packing). In case there are parts composed of different materials, refer to the competent bodies;
- each homogeneous group must be disposed of according to the laws governing the recycling of materials.

Alternatively, the machine can be sent to the Manufacturer for a thorough overhaul.

If the machine is not used anymore, it is recommended that batteries are removed and deposited at an authorized collecting centre.

Moreover, it is recommended that you make harmless those parts of the machine that could be dangerous especially to children, who could use the machine for their games.

## 5. HANDLING AND INSTALLATION

### 5.1. Lifting and carrying the packed machine

#### WARNING

**In all lifting operations make sure that the packed machine has been tightly anchored to the pallet, in order to avoid any overturning or accidental falls.**

**Loading and/or unloading from the motor vehicles must be performed in an adequately lighted environment.**

The machine, which is packed on a wooden pallet by the Manufacturer, must be loaded by means of proper handling machines (refer to the EEC provision 89/392/CEE and following amendments), onto the carrier and, once it has arrived at the appointed destination, unloaded by similar means.

The heads and squeegees are packed in cardboard boxes without a pallet.

The packed machine body must be lifted only with a fork lift truck. Handle with care to avoid bumps or overturnings.

### 5.2. Checking the machine on delivery

On delivery check with attention that the package and the machine are not damaged. In the event that the machine has suffered any damages, report so to the carrier; before accepting the goods, reserve by written the right to present a claim for the refund of the damages.

### 5.3. Unpacking

#### WARNING

**On unpacking the machine, the operator must be provided with the necessary accessories (e.g. gloves, protective goggles etc.) to limit possible hazards of accidents.**

Unpack the machine in the following way:

- cut and remove the plastic straps with scissors or nippers;
- remove the cardbox;
- remove the envelopes inside the battery compartment (within the solution tank) and check its contents:
  - envelope 1: - test sheet;
  - warranty coupon;
  - user's and maintenance manual;
  - list of spare parts;
  - cards with serial numbers to order spare parts;
  - envelope 2: - 1 battery bridge with clips (for battery models only);
  - 1 pair of tweezers for fuses (for battery models only);
  - 1 connector for the battery-charger (for battery models only);
- depending on the model, remove the metal brackets or cut the plastic straps, which fix the machine chassis to the pallet;
- let the machine slide down the pallet on an inclined plane, by pushing it into reverse;
- unwrap the brush (fig. 3, ref. 1) and the squeegee (fig. 3, ref. 2) from their packing;
- clean the outside of the machine observing the safety rules;
- after unpacking the machine, you can install the batteries (models with battery) or perform the electric connections (models with cable): see respective paragraphs.

If necessary, preserve the wrapping material as it could be used again to protect the machine in the event of a move or if the machine should be sent to a service centre for repair.

Otherwise, the material must be disposed of in compliance with the laws in force.

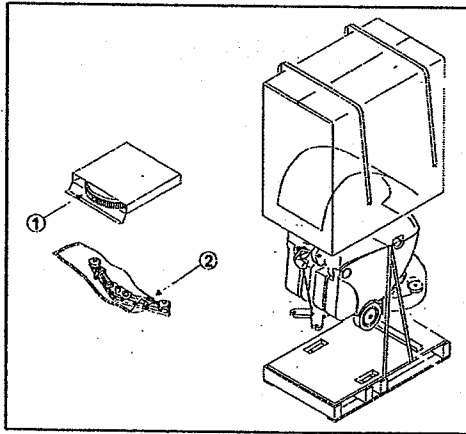

Fig. 3

#### 5.4. Feeding batteries

Two different batteries can be fitted on this machine:

- **Tubular leak-proof batteries:** these batteries require the periodical check of the electrolyte level. When it is necessary, top up with distilled water alone until the plates are covered; do not overfill (max. 5 mm. above the plates).
- **Gel batteries:** this kind of batteries requires no maintenance.

The technical specifications must correspond to those indicated in the paragraph concerning the machine technical data: actually, the use of heavier storage batteries can cause serious problems to the machine controllability and overheat the brush motor, whereas storage batteries with a lower capacity require recharges more frequently. They must be kept charged, dry and clean, with their connections tight.

#### 5.4.1. Batteries: preparation

### ! DANGER

On installing or performing any kind of maintenance on the batteries wear the necessary accessories (e.g. protective gloves, goggles, overalls, etc.) to limit the hazards of accidents, keep away from possible free flames, do not short-circuit the battery poles, cause sparks or smoke.

The batteries are normally supplied filled with acid and ready-for-use. If batteries without acid are to be used, before mounting them on the machine, it is necessary to make them active as follows:

- after taking off the battery plugs, fill up all elements with a solution of specific sulphuric acid, until the cells are thoroughly covered (fill each element at least twice);
- let them rest for about 4-5 hours, to give time to air bubbles to come up to the surface and the plates to absorb the electrolyte;
- check that the electrolyte level is still above the plates, otherwise top up with the solution of sulphuric acid;
- reclose the plugs;
- install the storage batteries on the machine (following the procedure described below).

It is now necessary to perform a first recharging before having the machine start; to do so stick to the instructions written in the respective paragraph.

#### 5.4.2. Batteries: installation and connection

### ! DANGER

Check that all switches on the control panel are at the position "0" (off). Mind you connect only the clips marked with the symbol "+" to the positive poles. Do not check the battery charge by creating sparkles.

Stick scrupulously to the instructions described below, as any short circuits of the batteries may cause them to explode.

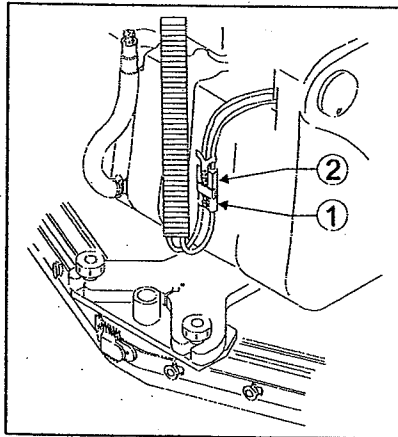

Fig. 4

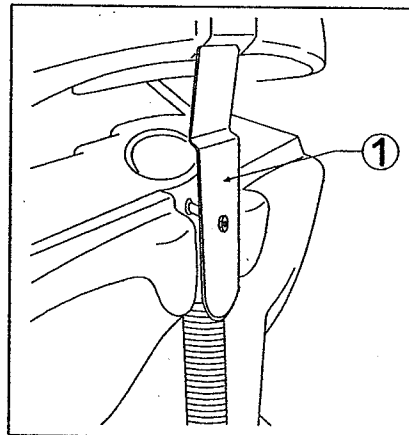

Fig. 5

- 1) Make sure that the two tanks are empty (empty them, if necessary: see respective paragraph);
- 2) disconnect the Anderson connector (fig. 4, ref. 2) of the battery wiring from the corresponding Anderson connector (fig. 4, ref. 1) of the main wiring;
- 3) unhook the recovery tank (fig. 2, ref. 2) from the solution tank (fig. 2, ref. 7) acting on the blocking hook (fig. 5, ref. 1), placed on front of the machine;
- 4) lift the recovery tank, by making it turn backwards around about 90°: in this way you

- have access to the battery compartment (embedded in the solution tank) from the upper side;
- 5) insert the batteries in the compartment, orienting them as shown in the drawing printed on the solution tank in the compartment.

## **WARNING**

**Install the storage batteries on the machine using suitable means according to their weight.**

**Positive and negative poles have different diameters.**

- 6) Referring to the arrangement of cables in the aforesaid drawing, connect the clips of the battery wiring and the bridge to the poles of the storage batteries. After orienting the cables as shown in the drawing, tighten the clips at the poles and cover them with vaseline;
- 7) insert back the tank unit in its work position and hook it to the solution tank by means of the fixing hook (fig. 5, ref. 1);
- 8) after having checked that all switches on the control panel are at the position "0" (off), connect the battery wiring connector (fig. 4, ref. 2) to the machine wiring connector (fig. 4, ref. 1);
- 9) use the machine in compliance with the instructions written below.

### 5.5. The battery-charger

## **WARNING**

**Never let the batteries run down excessively, as they could become damaged irreparably.**

#### 5.5.1. Choosing the battery-charger

Check that the battery-charger is compatible with the batteries to be charged:

- **tubular lead batteries:** an automatic battery-charger 24V - 20A is suggested. Anyway, refer to the Manufacturer and read the relative manual to confirm your choice;
- **gel batteries:** use a battery-charger specifically intended for this type of storage batteries.

#### 5.5.2. Preparing the battery-charger

If you wish to use a battery-charger not supplied with the machine, it is necessary to mount on it the connector delivered with the machine (see paragraph "Unpacking" of this manual).

To install the connector proceed as follows:

- remove about 13 mm of sheath from the black and red cables of the battery-charger;
- insert the cables in the connector pins and push strongly with suitable pliers;
- insert the cables in the connector respecting the polarity (red cable +, black cable -).

## 5.6. Lifting and handling the machine

### WARNING

All stages must be performed in an adequately lighted environment adopting all necessary safety measures.

Always wear individual protections for the user's safety.

The loading of the machine onto a vehicle must be done as follows:

- empty the recovery tank and the solution tank;
- remove the squeegee and the brush (or drive disc);
- remove the batteries (in models with battery);
- put the machine on the pallet, by anchoring it with plastic straps or the proper metal brackets;
- lift the pallet by means of a fork lift truck and load it on the vehicle;
- anchor the machine to the vehicle with ropes connected to the pallet and to the chassis of the machine.

## 6. PRACTICAL GUIDE FOR THE USER

### 6.1. Control devices - Description

With reference to fig. 6 the machine has the following controls and leds:

- 1) **Battery charge check led** (ref. 1 – in models with battery only): it is red and it indicates that the machine is fed and the level of the battery charge. It can be:
  - a) **off**: the battery is disconnected and all switches are at the position "0" (off);
  - b) **on**: the machine is connected to the batteries and the batteries are charged;
  - c) **flashing at a steady frequency**: the machine is on, but the batteries are nearly flat and therefore must be recharged.
- 2) **Main switch - emergency button with key** (ref. 2): enables or disables the power supply to all the machine functions. It acts as a safety device. To start the machine turn the proper key clockwise. To stop the machine press the button.

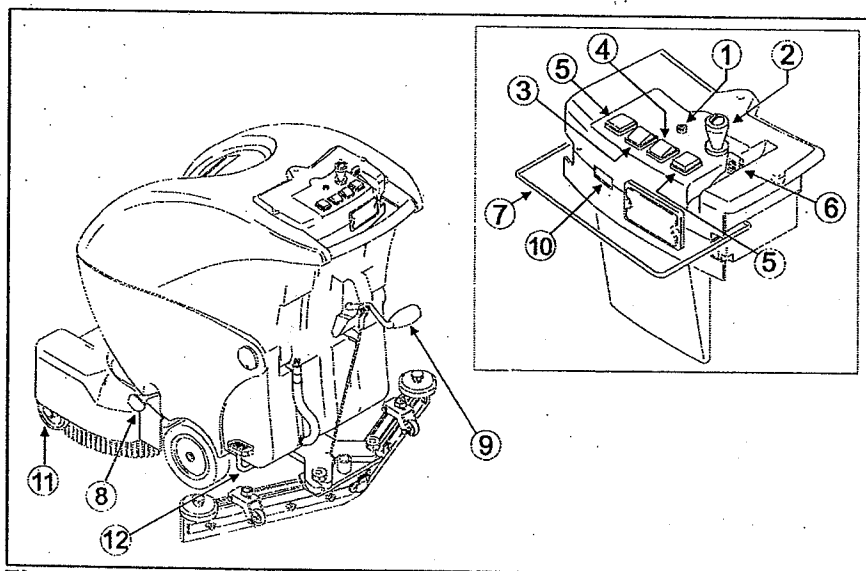

Fig. 6

- 3) **Brush switch with led** (ref. 3): enables ("1") or disables ("0") the function "Brush".
- 4) **Suction switch with led** (ref. 4): switches on ("1") or off ("0") the suction motor, which allows to dry the floor just washed. The led is on when the suction unit is fed.

- 5) **Switch top** (ref. 5).
- 6) **Cock control lever** (ref. 6): allows to adjust continuously the flow of solution sent to the brushes. On turning it forward, the liquid outlet flow is increased.
- 7) **Brush control lever** (ref. 7): located beneath the handle, if it is pressed when the brush switch (ref. 3) is at position "1", the motor switches on, which makes the brush turn and the machine start. The scrubber is equipped with a special mechanical driving system, thanks to which the friction of the brush against the floor is exploited to generate a push forward.
- 8) **Direction adjusting knob** (ref. 8): by turning it, any tendency of the machine to deviate from the straight direction is corrected.
- 9) **Squeegee lifting lever** (ref. 9): it allows to raise (when lifted) or lower (when pushed down) the squeegee.
- 10) **Hour meter** (ref. 10 - optional): displays the hours of work of the brush;
- 11) **Carriage small wheel** (ref. 11): if lowered, it makes the handling of the machine easier when the brush motor is off.
- 12) **Carriage small wheel up pedal** (ref. 12): it allows to lift the carriage small wheel if this pedal is pressed downwards.

## 6.2. Installing and adjusting the squeegee

The floor wiper, also called squeegee (fig. 2, ref. 6), is the first responsible for drying.

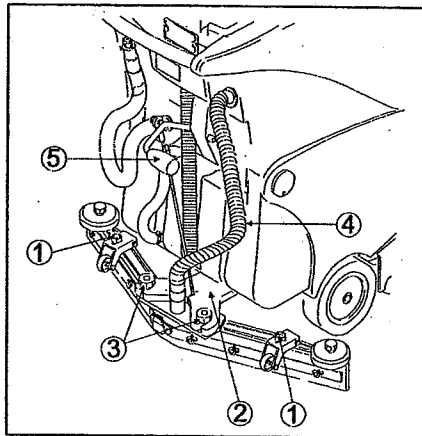

Fig. 7

To install the squeegee on the machine proceed as follows:

- 1) check that the squeegee supporting plate (fig. 7, ref. 2) is raised, otherwise lift it by acting on the proper lever (fig. 7, ref. 5);
- 2) firmly push down the sleeve of the suction tube (fig. 7, ref. 4) into the squeegee;
- 3) slacken the two knobs (fig. 7, ref. 3) placed in the centre of the squeegee;
- 4) insert the two threaded dowels in the slots of the support (fig. 7, ref. 2);
- 5) fix the squeegee by tightening the knobs (fig. 7, ref. 3).

The blades of the squeegee are used to scrub from the floor the film of water and detergent thus allowing a perfect drying. As long as time goes by the continuous scraping rounds off and splits the sharp edge in contact with the floor, thus reducing the drying efficacy and therefore requiring the replacement of the blades. Therefore, often check their state of wear and tear.

To obtain a perfect drying action it is necessary to adjust the squeegee in such a way that when it is in operation, the rear blade lip is bent about 45 degrees with respect to the floor at all points. It is possible to adjust the inclination of the blades by screwing down the nuts (fig. 7, ref. 1): by unscrewing the nuts the blade inclination is reduced, while by screwing the nuts the blade inclination is increased.

### 6.3. Moving the machine

The machine is equipped with the small carriage wheel (fig. 8, ref. 1); to move the machine, it is sufficient to lower the small carriage wheel, perform the following operations:

- 1) lift the squeegee;
- 2) lift the front part of the machine by pushing on the handle downwards: in this way, you lower the carriage small wheel, placed under the brush cover,
- 3) push forward the machine.

Once you have arrived at the desired place, lift the small wheel by pressing downwards the pedal (fig. 9, ref.1).

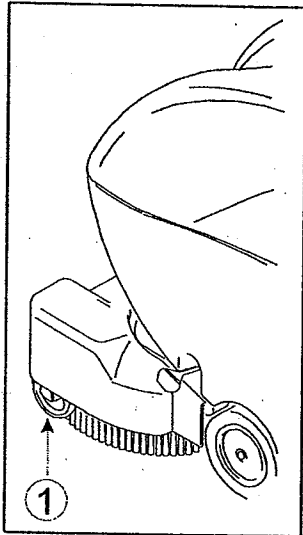

Fig. 8

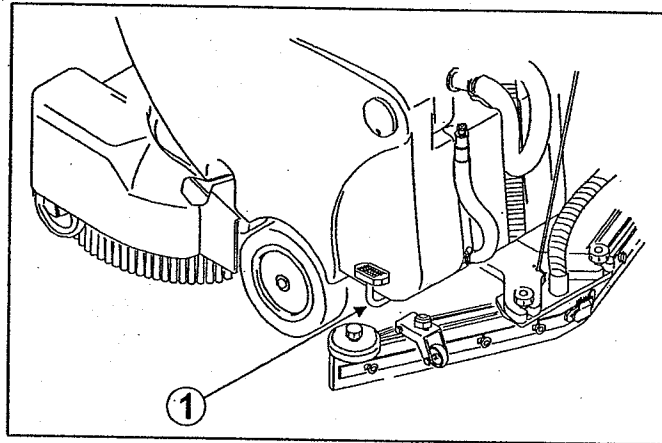

Fig. 9

### WARNING

Do not leave the machine unattended or parked with the carriage wheel lowered or with the key inserted in the emergency button.

### 6.4. Installing and replacing the brush / drive disc

### WARNING

Do not work if the brush or drive disc are not perfectly installed.

Feed the machine: insert and operate the key to release the emergency button (fig. 6, ref. 2) and press "1" on the brush switch (fig. 6, ref. 3).

To install the brush, lay it on the floor before the machine, stand at the rear of the scrubber and push on the handle in order to lift its front part and to lower the carriage small wheel (fig. 6, ref. 11). Go ahead (holding down the handle) and centre the flange on the brush. Lift the carriage small wheel (fig. 6, ref.11) pressing on the proper pedal (fig. 6, ref. 12), resting then the machine on the brush. Operate the brush control lever (fig. 6, ref. 7) for short instants: the brush is "screwed" in the hub automatically. If the operation is not successful, press on the handle again and repeat the centering operation pressing the brush control lever.

To use an abrasive disc, mount it on the drive disc and perform the operations described for the installation of the brush.

To remove the brush (or drive disc) do alternatively one of the following actions:

- a) lift the front part of the machine by pressing on the handle and operate the brush control lever for short instants. After few pushes the brush (or drive disc) comes

- uncoupled and falls down;
- b) push the machine forward, press on the handle raising the front part of the machine slowly, letting the scrubber keep going forward. The brush (or drive disc) comes uncoupled grazing against the floor.

#### 6.5. Detergents - Use

### WARNING

**Always dilute detergents according to the supplier's instructions. Do not use sodium hypochlorite (bleaching solution) or other oxidizers, especially if in high concentrations, and do not use solvents or hydrocarbons. The temperatures for water and detergent must not exceed the maximum temperatures indicated in the technical data and must be free from sand and/or other impurities.**

The machine has been designed to be used with non-foaming and biodegradable detergents specific for sweeping scrubbers.

Contact the Manufacturer to have a complete and updated list of the available detergents and chemical products; you will receive all papers together with the Manual "Complete cleaning system".

Use only products suitable for floors and for removing dirt.

Follow the safety rules concerning the use of detergents indicated in the paragraph "Safety regulations".

#### 6.6. Setting up the machine

### WARNING

**Before starting to work wear an apron, cap, non-slip waterproof shoes, a mask to protect the respiratory system, gloves and any other form of protection indicated by the supplier of the detergent or necessary in the environment you are going to work in.**

Before starting to work, perform the following operations:

- **Models with battery:** check the level of battery charge (recharge, if necessary);
- lift the small carriage wheel, if it is lowered;
- make sure that the recovery tank (fig. 2, ref. 2) is empty; if this is not so, empty it;
- check that the cock control lever (fig. 6, ref. 6) is at the position "off";
- fill the solution tank (fig. 2, ref. 7) through the respective hole on the front with clean water and non-foaming detergent in a suitable concentration: leave a difference in level of at least 5 cm between the liquid surface and the tank opening;
- install brushes or drive discs suitable for the floor and the job to be done;
- check that the squeegee (fig. 2, ref. 6) is fixed well and connected to the suction tube (fig. 7, ref. 4); make sure that the rear blade is not worn.

### INFORMATION

**If you use the machine for the first time, it is advisable that you train with it for a short time on a wide surface without any obstacles, to acquire the necessary familiarity.**

**Always empty the recovery tank before refilling the solution tank.**

For an effective cleaning and long life of the equipment, it is necessary to follow some simple rules:

- prepare the work area, keeping away the possible obstacles;
- begin to work starting from the farthest spot, in order to avoid trampling on the area just-cleaned;
- choose paths that are as much straight as possible;
- on wide floors divide the paths into rectangular and parallel areas.

At the end quickly mop the area, if necessary, to clean spots that are inaccessible to the scrubber.

## 6.7. Work

After setting up the machine, proceed as follows:

- connect the machine to the power supply:
  - *models with cable:* plug the machine;
  - *models with battery:* connect the ANDERSON connectors with each other (fig. 4, ref. 1 and ref. 2);
- insert and operate the key to release the emergency button (fig. 6, ref. 2), and make all the machine functions active: the power supply led lights up (fig. 6, ref. 1);
- press "1" on the main switch (fig. 6, ref. 2) to enable all the machine functions;
- move the cock lever (fig. 6, ref. 6) to the position of minimum flow of solution: the detergent solution begins to reach the brush;
- lower the squeegee by means of the proper lever (fig. 6, ref. 9);
- press "1" on the brush switch (fig. 6, ref. 3) to enable the function "Brush";
- press "1" on the suction unit switch (fig. 6, ref. 4) to start the suction motor;
- press the brush lever (fig. 6, ref. 7) beneath the handle: the brush motor starts. The brush turns and spreads the solution on the floor.

## i INFORMATION

As the machine has no driving motor, the advance is obtained by the brush rotation: actually the scrubber is provided with a special mechanical device, thanks to which the friction of the brush against the floor is exploited to generate a push forward. Therefore, on releasing the brush lever, the brush motor switches off and as a consequence the machine stops.

- If necessary, correct any tendency of the machine to deviate from the straight direction by acting on the direction adjusting knob (fig. 8, ref. 8): refer to the label attached next to the knob to correct the advance direction;
- check periodically that the detergent solution reaches the brush and fill with solution if it runs out;
- while working, check the quality of washing and, if necessary, adjust the flow of solution sent to the brush (by turning the lever (fig. 6, ref.6)).

## WARNING

Whenever you fill up the solution tank, always empty the recovery tank. Do not leave the machine stationary with the suction motor on and the solution cock turned on.

- *Models with battery:* if the warning led (fig. 6, ref. 1) starts flashing, it means that the storage batteries are getting flat. Therefore, it is necessary to recharge them, as there is no device blocking the total running of the machine; if you keep on working, the batteries could become damaged irreparably.

## WARNING

If the brush control lever (fig. 6, ref. 7) is operated intermittent for a long time, the brush motor could become overheated and therefore damaged. Moreover, in machines with cable the motor needs 2-3 seconds of rest to get started without strain. For this reason limit the "lever shots" to the sole events when they are strictly necessary.

At the end of work:

- move the cock lever (fig. 6, ref. 6) to the position "CLOSED";
- release the brush lever (fig. 6, ref. 7) placed beneath the handle: the brush motor switches off and the machine stops;
- press "0" on the brush switch (fig. 6, ref. 3) to disable the function "Brush";
- raising the lever (fig. 6, ref. 9), lift the scrubber from the floor to prevent the drying

- blades from warping due to the continuous pressure;
- let the suction motor run for at least 2 minutes to make sure that it is completely dry; then press "0" on the suction unit switch (fig. 6, ref. 4) to switch off the suction motor;
- press the main switch (fig. 6, ref. 2) to disable all the machine functions;
- remove the brush (or drive disc) to prevent it from warping permanently;
- depending on the model, unplug the machine or disconnect the ANDERSON connectors (fig. 4, ref. 1 and ref. 2);
- empty and clean the recovery tank.

### 6.8. Some useful suggestions for the optimal use of the machine

If the floor presents a particularly resistant type of dirt, it is possible to make the machine wash and dry it in separate stages.

#### 6.8.1. Pre-washing

- Turn on the water cock;
- switch on the brush motor;
- start washing with the suction motor off and the squeegee lifted.

The flow of water must be dosed in proportion to the desired advance speed: the slower the machine goes, less water comes down.

Insist on washing the dirtiest spots: in this way the detergent has the time to perform its chemical action for the detachment and suspension of dirt, and the brushes to develop an effective mechanical action.

#### 6.8.2. Drying

Lower the squeegee and with the suction unit operating pass again on the same area you have previously washed. In this way you obtain a result that is similar to a thorough washing and the following operations of ordinary maintenance will certainly take less time. To wash and dry at the same time, operate the brush, water, squeegee and suction motor simultaneously.

### 6.9. Draining off dirty water

**! DANGER**

**Use the individual protection devices suitable for the operation to be performed. Perform the draining operations with the machine disconnected from the power supply.**

The drain hose of the recovery tank is located at the rear left side of the machine. To empty the above-mentioned tank:

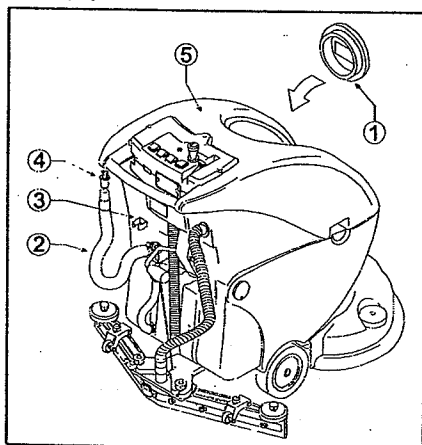

Fig. 10

- take the machine next to a drain;
- take off the tank cap (fig. 10, ref. 1) from the recovery tank (fig. 10, ref. 5);
- detach the drain hose (fig. 10, ref. 2) from its seat, holding it in correspondence with the fixing spring (fig. 10, ref. 3) and pull it horizontally;
- keeping the hose end as much high as possible, take off the drain cock (fig. 10, ref. 4) by unscrewing it;
- lower the hose end gradually, checking the intensity of the jet of water with reference to its height from the ground;
- check the amount of residual dirt in the recovery tank and wash it inside, if necessary. To facilitate the cleaning and total drain, it is better to unhook it from the solution tank and lift it;
- when the dirty water has been totally drained, lower the recovery tank (if it has been previously lifted) and hook it again to the solution tank;
- put back the cap (fig. 10, ref. 1) on the recovery tank, making sure that it is perfectly closed;
- close the drain hose (fig. 10, ref. 2) with the cock (fig. 10, ref. 4) screw-tightening it; check that it is perfectly closed and refit the hose in its housing.

## ⚠ WARNING

**While washing the recovery tank never remove the suction filter (fig. 12, ref. 2) from its seat and never direct the jet of water towards the filter itself.**

Now it is possible to proceed with a new washing and drying action.

### 6.10 Draining off clean water

## ! DANGER

**Use the individual protection devices suitable for the operation to be performed. Perform the draining off operations with the machine disconnected from the power supply.**

To empty the tank:

- take the machine next to a drain;
- detach the drain hose (fig. 11, ref. 1) from its seat, holding it in correspondence with the fixing spring (fig. 11, ref. 2) and pull it horizontally;

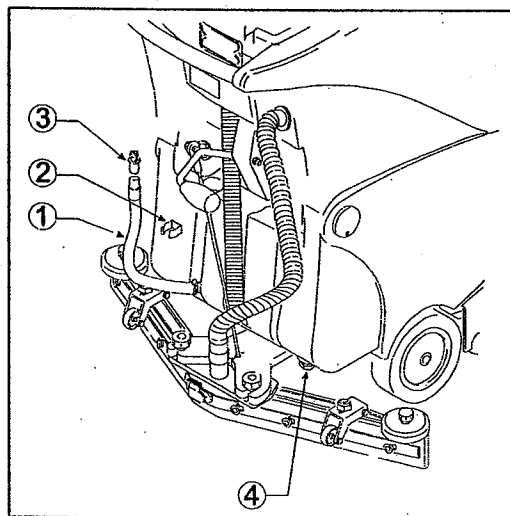

**Fig. 11**

- keeping the hose end as much high as possible, take off the drain cock (fig. 11, ref. 3) by unscrewing it;
- lower the hose end gradually, checking the intensity of the jet of water with reference to its height from the ground;

- when the contents have been totally drained from the solution tank, close the drain hose with the cock (fig. 11, ref. 3) screw-tightening it; check that it is perfectly closed, and refit the hose in its housing.

## i INFORMATION

The water and detergent solution can also be used to wash the recovery tank.

## 7. PERIODS OF INACTIVITY

If the machine is to remain unused for a long time, the squeegee and brush (or drive disc) must be dismantled, washed and kept in a dry place (preferably packed in a plastic envelope or sheet), sheltered from dust. Park the machine with the small carriage in the raised position.

Furthermore, make sure that the tanks are completely empty and perfectly clean.

Disconnect the machine from the power supply (depending on the model: unplug the machine from the mains or disconnect the ANDERSON connector from the battery wiring).

**Models with battery:** recharge the batteries completely before putting them in the storehouse. During long periods of inactivity recharge the batteries (once every two months at least) to preserve the storage batteries constantly at the maximum charge.

## ! WARNING

If the batteries are not recharged periodically, they may become damaged irreparably.

## 8. MAINTENANCE AND BATTERY RECHARGING

### ! DANGER

Do not check the battery charge by producing sparks.

The batteries give off inflammable vapours: put out any fire or embers before checking and filling up the batteries.

Perform the operations described below in airy environments.

To avoid permanent damages to the batteries, never let them get flat completely.

Remember that when the proper red led (fig. 6, ref. 1) flashes on the control panel, it is necessary to recharge the batteries.

### 8.1. Recharging procedures

**Lead batteries with liquid electrolyte:**

It is necessary to check the level of the electrolytic solution in order that it always covers the films of the elements, adding the necessary distilled water.

### ! WARNING

Do NOT connect the battery-charger to the connector of the machine main wiring.

During recharging do not let the temperature of the electrolyte exceed 45°C.

To recharge proceed as follows:

- detach the recovery tank (after having emptied it) from the solution tank, acting on

- the blocking hook (fig. 5, ref. 1) located on front of the machine;
- lift the recovery tank up;
  - disconnect the battery wiring connector (fig. 4, ref. 2) from the main wiring connector (fig. 4, ref. 1);
  - connect the battery-charger to the battery wiring connector;
  - recharge according to the instructions written in the manual to the battery-charger;
  - at the end of the recharging time check the battery intensity with a densimeter: if one or more elements are flat and the remaining ones completely charged, the battery is damaged and must be replaced;
  - reclose the caps;
  - bring the recovery tank back to the work position and hook it to the solution tank by the blocking hook;
  - reconnect the battery wiring connector to the machine connector.

**Gel batteries:**

- disconnect the battery wiring connector (fig. 4, ref. 2) from the main wiring connector (fig. 4, ref. 1);
- connect the battery-charger connector to the battery wiring connector;

 **WARNING**

**Do NOT connect the battery-charger to the machine main wiring connector.**

**Use only a battery-charger that is specific for gel storage batteries.**

- recharge following the instructions written in the manual to the battery-charger;
- at the end of the recharging time disconnect the connectors;
- reconnect the battery wiring connector to the machine connector.

## 9. INSTRUCTIONS FOR MAINTENANCE

### **! DANGER**

Before carrying out any maintenance operations, unplug the machine from the mains (models with cable) or disconnect the machine connector from the battery connector.

All maintenance operations on the electric system and those not explicitly described in this manual must only be performed by trained technical staff in compliance with the safety regulations in force and recommendations stated in the maintenance manual.

#### 9.1. Maintenance – General rules

A regular maintenance performed according to the Manufacturer's instructions guarantees a better performance and endurance of the machine.

#### 9.2. Routine maintenance

##### 9.2.1. Daily cleaning

When cleaning the machine always observe the following instructions:

- avoid using water cleaners, which could let water go inside the electric or the motor compartments with a consequent damage or hazard of short circuits;
- do not use steam in order not to warp the plastic parts;
- do not use solvents or hydrocarbons, which could damage the hoods or the rubber parts.

### **i INFORMATION**

Do not use water on the motors or electric parts.

### 9.2.2. Suction air filter and floating rod: cleaning

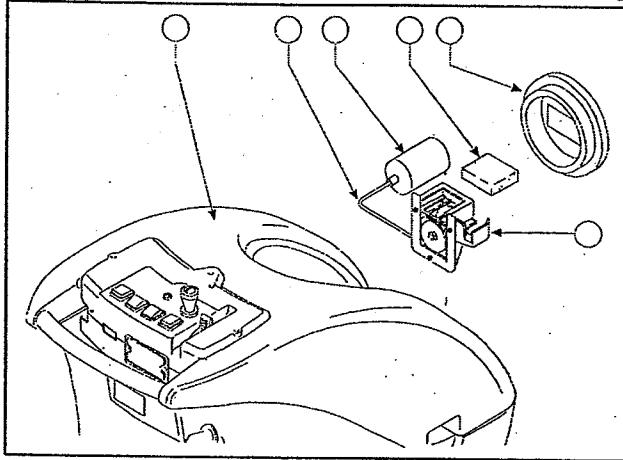

Fig. 12

- Unscrew and take off the tank cap (fig. 12, ref. 1) from the recovery tank (fig. 12, ref. 4);
- make sure that the recovery tank (fig. 12, ref. 4) is empty;
- take out the air filter (fig. 12, ref. 2) of the suction unit from the float support (fig. 12, ref. 3), which is located on the upper inner side of the recovery tank;
- clean the filter with current water or with the detergent used in the machine;
- put the filter back in the support only after having it dried well;
- make sure that the filter has been replaced in its seat correctly;
- check that the floating rod (fig. 12, ref. 5), which is also fixed to the support (fig. 12, ref. 3), moves freely and clean it, if necessary;
- screw again the cap on the recovery tank.

### 9.2.3. Squeegee blades: replacement

The blades of the squeegee are used to scrub from the floor the film of water and detergent thus allowing a perfect drying. As long as time goes by the continuous scraping rounds off and splits the sharp edge in contact with the floor, thus reducing the drying efficacy and therefore requiring the replacement of the blades. Therefore, often check their state of wear and tear.

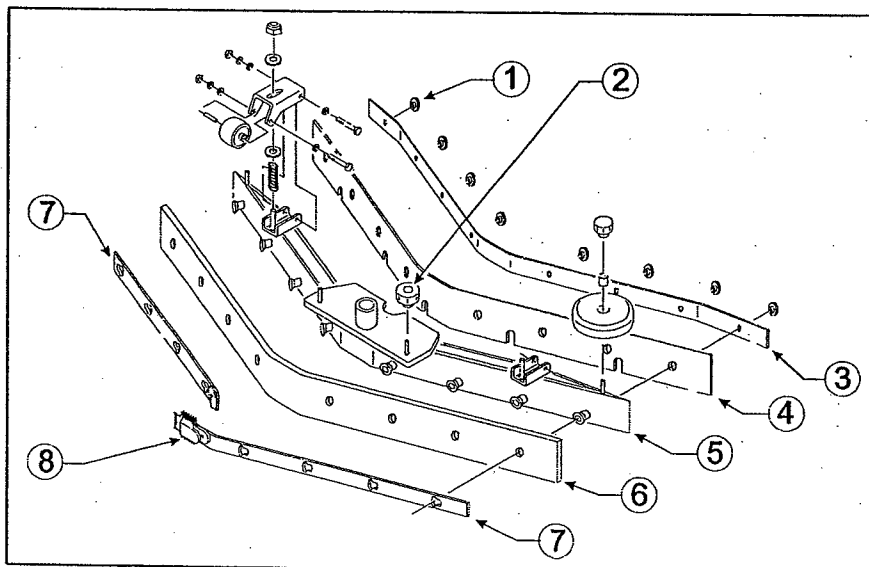

Fig. 13

### **Exchanging or replacing the blades:**

- lower the squeegee by using the proper lever (fig. 6, ref. 9);
- take off the squeegee (fig. 2, ref. 6) from its supporting plate (fig. 7, ref. 2) by unscrewing completely the two knobs (fig. 7, ref. 3);
- slide out the sleeve of the suction tube (fig. 7, ref. 4) from the squeegee.

#### **Front blade:**

- unscrew the knobs (fig. 13, ref. 1);
- remove the blade clamps (fig. 13, ref. 3);
- take out the blade (fig. 13, ref. 4);
- fit in the same blade inverting the edge in contact with the floor until all the four edges are worn, or else fit in a new blade;
- put the blade clamp (fig. 13, ref. 3) back;
- screw down all the knobs (fig. 13, ref. 1).

#### **Rear blade:**

- unhook the hook clamp (fig. 13, ref. 8);
- slide out the two blade clamps (fig. 13, ref. 7) by first pushing them outwards with respect to the squeegee unit (fig. 13, ref. 5) and then taking them out;
- remove the blade (fig. 13, ref. 6);
- fit in the same blade inverting the edge in contact with the floor until all the four edges are worn, or else fit in a new blade embedding it in the screws of the squeegee unit (fig. 13, ref. 5);
- put the two blade clamps (fig. 13, ref. 7) back, centering the largest part of the slots on the fixing screws of the squeegee unit (fig. 13, ref. 5) and then pushing the blade clamps towards the inside of the squeegee itself;
- hook the clamp (fig. 13, ref. 8) again.

Insert the squeegee back on its support following the instructions reported in §6.2.

### **9.2.4. Fuses: replacement**

To replace the fuses in the control panel of the machine, proceed as follows:

- remove the fuse cover (fig. 14, ref. 1);

**Models with cable:** the glass fuse of the suction unit is located inside the steering-wheel fuse holder;

- with the tweezers supplied with the machine take out the blown fuses and replace them with new ones of the same amperage;
- reclose the fuse cover.

**Models with battery:** the 60A fuse, which protects the brush motor, is in the fuse-holder (fig. 14, ref. 2) that is fixed to the solution tank inside the battery compartment of the machine.

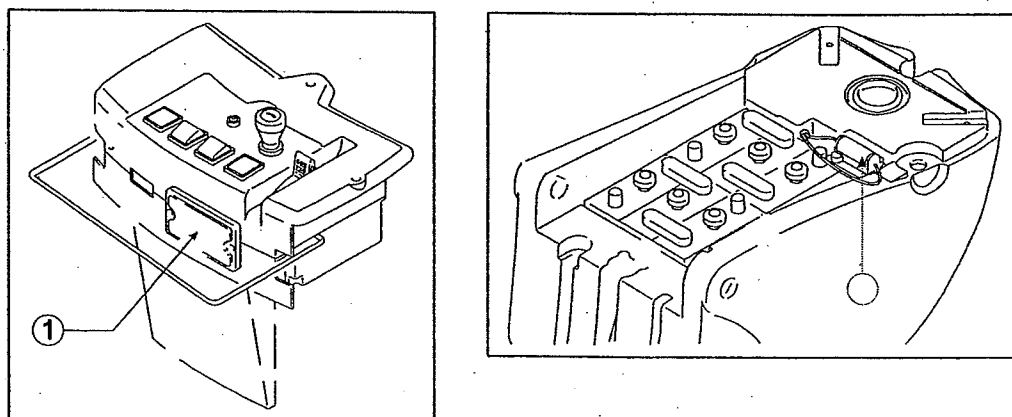

Fig. 14

To replace it:

- make sure that the recovery tank is empty, otherwise empty it;
- lift the recovery tank;
- lift the fuse cover and take out the fuse, removing the fixing screws;
- install a new fuse and reclose the fuse-holder cover;
- finally, lower the recovery tank.

**Fuse chart:** for a chart of the fuses see the Catalogue of Spare Parts.

## **WARNING**

**Never fit a fuse with a higher Amp value than the intended one.**

If a fuse keeps burning, it is necessary to identify and repair the damages present in the wiring, boards (if fitted) or motors: have the machine checked by trained technical staff.

### **9.3. Periodic maintenance**

#### **9.3.1. Daily maintenance**

Every day at the end of work perform the following operations:

- disconnected the machine from the power supply;
- empty the recovery tank and clean it, if necessary;
- clean the squeegee blades, checking that they are not excessively worn; replace them, if necessary;
- make sure that the squeegee suction hole is not clogged, freeing it from any encrusted dirt;
- **Models with battery:** recharge the batteries according to the procedure described above.

#### **9.3.2. Weekly maintenance**

- Clean the floating rod of the recovery tank and check that it works correctly;
- clean the suction air filter and check that it is not damaged (replace it, if necessary);
- clean the solution filter placed at the front opening of the solution tank (fig. 2, ref. 7) and check that it is not damaged (replace it, if necessary);
- clean the suction tube;
- clean the recovery tank and the solution tank;

**Models with battery:** check the level of the electrolyte in the batteries and top up with distilled water, if necessary.

#### **9.3.3 Six-monthly maintenance**

Have the electric system, calibrations and tension of the brush motor belts checked by qualified staff.

## 10. HOW TO ORDER SPARE PARTS

For a correct identification by our After-sales Service Office of the spare part(s) you need and, therefore, to help us serving you better, please fill in your orders with the following data:

- machine model;
- machine serial number on the identification plate (see fig. 1);
- chart of the list of spare parts in which the item and its reference number are found;
- code of the item to be found in the list of spare parts;
- amount ordered.

If you ask for a replacement under warranty terms, the order must be completed with a brief description of the fault.

# 11. TROUBLESHOOTING

## 11.1. How to overcome possible failures

Possible failures affecting the whole machine

FAILURES	CAUSES	REMEDIES
<b>The machine does not work</b>	• the battery connector is disconnected	• connect the batteries to the machine
	• the batteries are flat	• recharge the batteries
	• the emergency button is pressed or faulty	• insert the key, turn and release or replace the button
<b>The brushes do not turn</b>	• the emergency button is pressed or faulty	• insert the key, turn and release or replace the button
	• the brush switch is at the position "0"	• turn the brush switch to position "1"
	• the brush lever is not pressed	• press the brush lever
	• the brush motor thermal protection has tripped: the motor has become overheated	• release the brush lever, turn the brush switch to position "0" (off), letting the machine cool down for at least 45'
	• the power supply connector or the motor thermal protection connector are disconnected	• connect again the power supply connector or the motor thermal protection connector
	• the thermal protection fuse (F6) and/or the 60A (F7) fuse of the brush motor have blown	• check and remove the causes that made the fuse blow, then replace it
	• the brush microswitch is not calibrated or is faulty	• have the microswitch calibrated or replaced
	• the brush motor contactor is faulty	• have the contactor replaced
	• the batteries are flat	• recharge the batteries
	• the belt is broken	• have the belt replaced
	• the motor is faulty	• have the motor replaced
<b>The brush motor has trouble in starting (in models with cable only).</b>	• you are working with a dry brush on a very rough floor	• turn on the detergent solution cock
	• you are working with extensions having an inadequate section on the power supply cable, or the voltage is sensibly lower than that intended for the scrubber (15% less)	• avoid the use of inadequate extensions. Increase the section of the electric wires and find out sockets with a higher voltage
	• the motor is faulty	• have the motor replaced

<b>The machine does not wash evenly</b>	<ul style="list-style-type: none"> <li>• the brush or abrasive disc is worn</li> </ul>	<ul style="list-style-type: none"> <li>• replace them</li> </ul>
<b>The brush keeps on turning also when the main switch and/or brush switch have been pressed.</b>	<ul style="list-style-type: none"> <li>• the brush contactor is faulty</li> </ul>	<ul style="list-style-type: none"> <li>• have it replaced</li> </ul>
<b>The solution does not come out</b>	<ul style="list-style-type: none"> <li>• the cock control lever is at the position "CLOSED"</li> </ul>	<ul style="list-style-type: none"> <li>• move the lever to the position "OPEN"</li> </ul>
	<ul style="list-style-type: none"> <li>• the solution tank is empty</li> </ul>	<ul style="list-style-type: none"> <li>• fill it up</li> </ul>
	<ul style="list-style-type: none"> <li>• there is an obstruction in the tube through which the solution is pumped to the brush</li> </ul>	<ul style="list-style-type: none"> <li>• remove the clogging, cleaning the ducts</li> </ul>
	<ul style="list-style-type: none"> <li>• the tap is dirty or does not work</li> </ul>	<ul style="list-style-type: none"> <li>• clean or replace the tap, unscrewing the screw ref. 4 in fig. 11</li> </ul>
<b>The flow of solution keeps coming to the brush</b>	<ul style="list-style-type: none"> <li>• the tap remains open, because it is damaged or very dirty</li> </ul>	<ul style="list-style-type: none"> <li>• clean or replace the tap</li> </ul>
<b>The suction motor does not work</b>	<ul style="list-style-type: none"> <li>• the suction unit switch is at the position '0' (off)</li> </ul>	<ul style="list-style-type: none"> <li>• operate the suction unit switch</li> </ul>
	<ul style="list-style-type: none"> <li>• the suction motor is not fed or is faulty</li> </ul>	<ul style="list-style-type: none"> <li>• check that the motor power supply connector is connected to the main wiring in the right way; in the second case have the motor replaced</li> </ul>
	<ul style="list-style-type: none"> <li>• the fuse has blown (F3)</li> </ul>	<ul style="list-style-type: none"> <li>• replace the fuse F3</li> </ul>
	<ul style="list-style-type: none"> <li>• the batteries are flat</li> </ul>	<ul style="list-style-type: none"> <li>• recharge the batteries</li> </ul>
<b>The squeegee does not clean or suck well</b>	<ul style="list-style-type: none"> <li>• the edge of the rubber blades in contact with the floor is rounded off</li> </ul>	<ul style="list-style-type: none"> <li>• replace the rubber blade</li> </ul>
	<ul style="list-style-type: none"> <li>• there is an obstruction or damage in the squeegee or in the tube</li> </ul>	<ul style="list-style-type: none"> <li>• remove the obstruction and repair the damage</li> </ul>
	<ul style="list-style-type: none"> <li>• the float has intervened (recovery tank full), or is blocked by dirt or broken</li> </ul>	<ul style="list-style-type: none"> <li>• empty the recovery tank or make the necessary repairs to the float</li> </ul>
	<ul style="list-style-type: none"> <li>• there is an obstruction in the suction tube</li> </ul>	<ul style="list-style-type: none"> <li>• free the tube from the obstruction</li> </ul>
	<ul style="list-style-type: none"> <li>• the suction tube is not connected to the squeegee or is damaged</li> </ul>	<ul style="list-style-type: none"> <li>• connect or repair the tube</li> </ul>
	<ul style="list-style-type: none"> <li>• the suction unit motor is not fed or is faulty</li> </ul>	<ul style="list-style-type: none"> <li>• check that the motor power supply connector is connected to the main wiring in the right way and that the protection fuse has not blown; in the second case replace the motor</li> </ul>

<b>The machine does not move forward</b>	• the drive motor is not fed or is faulty	• in the first case turn the emergency switch key clockwise, set the brush switch to "1" and press the brush lever; in the second case check that the brush motor is connected to the main wiring in the right way; in the third case replace the motor
	• the belt is broken (therefore, the brush does not turn)	• have the belt replaced
	• the thermal protection of the brush motor has tripped: the motor has become overheated	• stop the machine and switch it off, letting it cool down for at least 45'
	• the microswitch is faulty or not calibrated	• replace or calibrate it
	• the batteries are flat	• recharge the batteries

<b>The machine tends to swerve to one side</b>	• the floor requires an adjustment on the direction adjusting knob	• adjust the advance direction acting on the speed adjusting knob
--	--	---

<b>The batteries do not ensure the normal work time (models with battery only)</b>	• the poles and charging clips of the batteries are dirty and oxydized	• clean and grease the poles and clips, recharge the batteries
	• the electrolyte level is low	• add distilled water topping up all elements according to the instructions
	• the battery-charger does not work or is unsuitable	• see instructions relative to the battery-charger
	• there are considerable differences in density between the various elements of the battery	• replace the damaged battery
	• the machine is working with a too high pressure on the brush	• reduce pressure on the brush

<b>The storage battery gets flat too fast during use, although it has been charged in the correct way and when tested with a densimeter at the end of recharging, it turned out to be uniformly charged (models with battery only)</b>	• the storage battery is new and does not give 100% of its expected capacity	• it is necessary to "run-in" the storage battery by 20-30 charges and discharges to obtain maximum performance
	• the machine is used at its maximum capacity for continuous periods and the autonomy is not sufficient	• use, if possible, storage batteries with larger capacity or replace the storage batteries with others already charged
	• the electrolyte has evaporated and does not cover the plates completely	• add distilled water, topping up all elements until the plates are covered and recharge the storage battery

The storage battery gets flat too fast during use, the recharging with an electronic battery-charger is too fast and at the end the storage battery gives the right voltage (about 2,14V for each empty element), but it turns out to be not uniformly charged when tested with densimeter (models with battery only)

- the storage battery, already filled with acid by the Manufacturer, has been stored for a too long time before being recharged and used for the first time

- if the recharging with a normal storage-charger is not effective, it is necessary to carry out a double recharging consisting in:
  - a slow recharging of about 10 hours with a current equal to 1/10 of the rated capacity expressed in 5 hours (ex.: for a storage battery of 100Ah(5), the current should be 10A, realized by a manual battery-charger);
  - one-hour pause;
  - charging with a normal battery-charger

After recharging with an electronic battery-charger the storage-battery does not show the correct voltage (about 2,14V for each empty element) and only one or few elements turn out to be flat when tested with densimeter (models with battery only).

- the storage battery has not been connected to the battery-charger (for instance because the low voltage connector of the battery-charger has been erroneously connected to the machine connector)

- connect the battery-charger to the storage battery connector

- the battery-charger and the power socket to which the storage battery is connected are not compatible

- check that the power supply characteristics indicated on the battery-charger plate are compliant with those of the mains

- the battery-charger has not been installed correctly

- taking into account the actual voltage available at the socket, check that the connections of the transformer primary circuit in the battery-charger are correct (at this purpose read the manual to the battery-charger)

- the battery-charger does not work

- check that there is voltage at the battery-charger, that the fuses are not interrupted and that there is current at the storage battery; in addition try to charge by means of another rectifier: if the battery-charger does not work, call the after-sales service staff communicating the serial number of the battery-charger

<p>After recharging with an electronic battery-charger the storage-battery does not show the correct voltage (about 2,14V for each empty element) and only one or few elements turn out to be flat when tested with densimeter (solo models with battery)</p>	<ul style="list-style-type: none"> <li>• one or more elements are damaged</li> </ul>	<ul style="list-style-type: none"> <li>• replace, if possible, the damaged elements. For monoblock storage batteries at 6V or 12V, replace the whole storage battery</li> </ul>
---	--	---

<p>The electrolyte that is present in the storage battery has a cloudy colour) (models with battery only)</p>	<ul style="list-style-type: none"> <li>• the storage battery has completed the charge/discharge cycles indicated by the Manufacturer</li> </ul>	<ul style="list-style-type: none"> <li>• replace the storage battery</li> </ul>
	<ul style="list-style-type: none"> <li>• the storage battery has been recharged with a too high current</li> </ul>	<ul style="list-style-type: none"> <li>• replace the storage battery</li> </ul>
	<ul style="list-style-type: none"> <li>• the storage battery has been charged beyond the limit suggested by the Manufacturer</li> </ul>	<ul style="list-style-type: none"> <li>• replace the storage battery</li> </ul>