

Watchman™ Auto Scrubbers

Owner's Manual and Parts Schematic

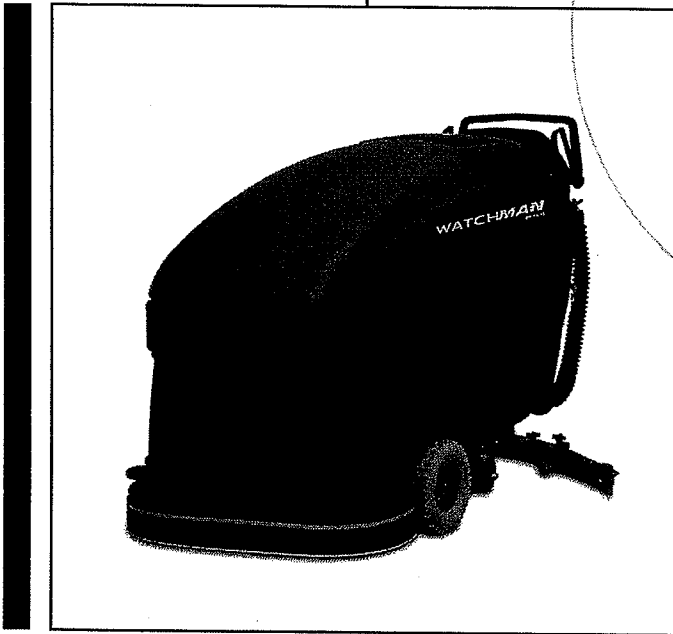

WS28
WS32

Item #87301
Item #87302

Better Resources. Better Results.
BETCO®

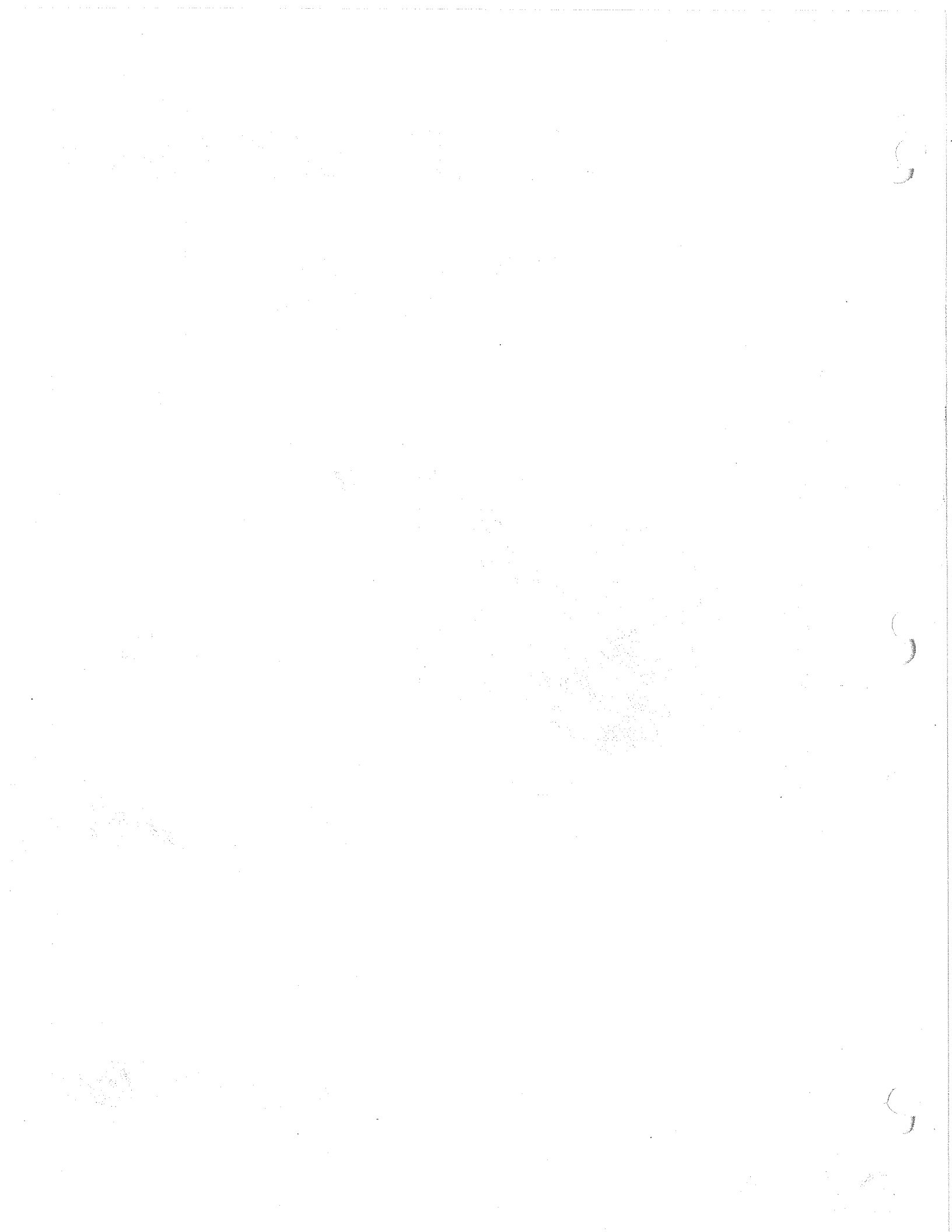

TABLE OF CONTENTS

<i>Machine Data Log/Overview</i>	2
<i>Table of Contents</i>	3

HOW TO USE THIS MANUAL

<i>How to use this Manual</i>	4
-------------------------------------	---

SAFETY

<i>Important Safety Instructions</i>	5
<i>Hazard Intensity Level</i>	6
<i>Safety Label Location</i>	7

OPERATIONS

<i>Technical Specifications</i>	8
<i>How the Machine Works</i>	10
<i>Controls</i>	11
<i>Machine Operation</i>	14
<i>Pre-Run Machine Inspection</i>	14
<i>Starting Machine</i>	14
<i>Emergency Stop Procedures</i>	14
<i>Filling the Solution Tank</i>	14
<i>Scrubbing</i>	14
<i>Emptying & Cleaning Tanks</i>	15

MAINTENANCE

<i>Batteries</i>	16
<i>Battery Maintenance</i>	16
<i>Checking Battery Specific Gravity</i>	16
<i>Charging the Batteries</i>	17
<i>Changing Batteries</i>	17
<i>Battery Connections</i>	17
<i>Scrub Brushes</i>	18
<i>Types</i>	18
<i>Replacing or Installing Scrub Brushes</i>	18
<i>Squeegee Blades</i>	19
<i>Adjusting Squeegee</i>	19
<i>Replace or Rotate Rear Squeegee Blade</i>	19
<i>Replace or Rotate Front Squeegee Blade</i>	19
<i>Adjusting Squeegee Pitch</i>	20
<i>Adjusting Rear Deflection</i>	20
<i>Scrub Deck Skirt/Squeegee Blades</i>	20
<i>Tires & Wheels</i>	20
<i>Service Schedule</i>	21

GROUP PARTS LIST

<i>Control Handle Group</i>	22
<i>Control Tower Group</i>	24
<i>Decal Group</i>	26
<i>Electrical Panel Group</i>	28
<i>Front Cover Group</i>	30
<i>Recovery Tank Group</i>	32
<i>Scrub Brush/Pad Driver Group – 32in.</i>	34
<i>Scrub Brush/Pad Driver Group – 28in.</i>	36
<i>Scrub Head Group – 28in.</i>	38
<i>Scrub Head Group – 32in.</i>	40
<i>Scrub Head Lift Group</i>	42
<i>Solution Tank Group</i>	44
<i>Squeegee Group – 28in Scrub Head</i>	46
<i>Squeegee Lift Group</i>	48
<i>Vacuum Group</i>	50
<i>Wheels and Frame Group</i>	52
<i>Wiring Group – Battery Cables</i>	54
<i>Wiring Group – Control Panel</i>	56
<i>Wiring Group – Main Harness</i>	58
<i>Wiring Group – Schematic</i>	60
<i>Suggested Spare Parts/Notes</i>	61
<i>Option – Brake</i>	62
<i>Option – Emergency Stop</i>	64
<i>Option – Hour Meter</i>	66
<i>Option – Quick Scrub Head Connect</i>	68
<i>Option – Smart Squeegee 24in & 26in</i>	70
<i>Option – Smart Squeegee 28in</i>	72

HOW TO USE THIS MANUAL

This manual contains the following sections:

- HOW TO USE THIS MANUAL
- SAFETY
- OPERATIONS
- MAINTENANCE
- PARTS LIST

The HOW TO USE THIS MANUAL section will tell you how to find important information for ordering correct repair parts.

When placing an order for parts, the machine model and machine serial number are important. Refer to the MACHINE DATA box which is filled out during the installation of your machine. The MACHINE DATA box is located on the inside of the front cover of this manual.

MODEL	_____
DATE OF PURCHASE	_____
SERIAL NUMBER	_____
SALES REPRESENTATIVE #	_____
DEALER NAME	_____
OPERATIONS GUIDE NUMBER	_____
PUBLISHED	_____

The model and serial number of your machine is on the bottom back-end of the machine.

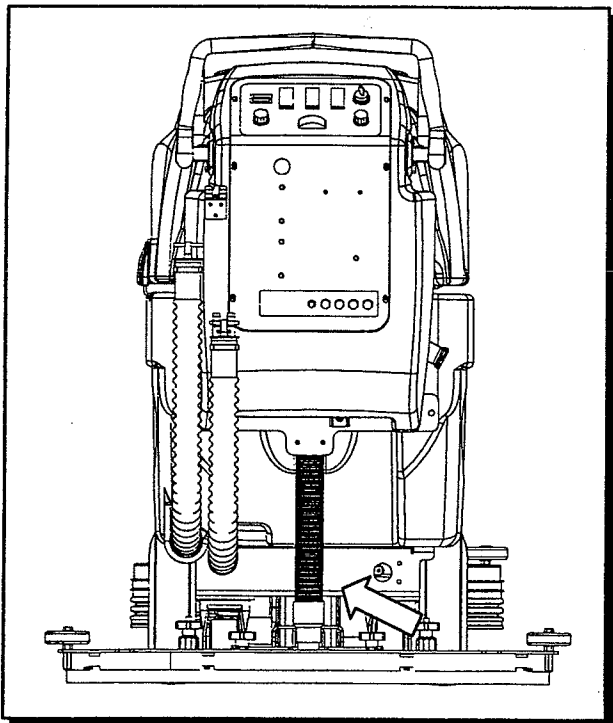

The SAFETY section contains important information regarding hazard or unsafe practices of the machine. Levels of hazards are identified that could result in product or personal injury, or severe injury resulting in death.

The OPERATIONS section is to familiarize the operator with the operation and function of the machine.

The MAINTENANCE section contains preventive maintenance to keep the machine and its components in good working condition. They are listed in this general order:

- Batteries
- Scrub Brushes
- Adjusting Squeegee
- Scrub Deck Skirt
- Squeegee Blade/Brush Head Options
- Service Schedule

The PARTS LIST section contains assembled parts illustrations and corresponding parts list. The parts lists include a number of columns of information:

- **REF** – column refers to the reference number on the parts illustration.
- **PART NO.** – column lists the part number for the part.
- **QTY** – column lists the quantity of the part used in that area of the machine.
- **DESCRIPTION** – column is a brief description of the part.
- **SERIAL NO. FROM** – column indicates the first machine the part number is applicable to. When the machine design has changed, this column will indicate serial number of applicable machine. The main illustration shows the most current design of the machine. The boxed illustrations show older designs.
- **NOTES** – column for information not noted by the other columns.

(NOTE: If a service or option kit is installed on your machine, be sure to keep the KIT INSTRUCTIONS which came with the kit. It contains replacement parts numbers needed for ordering future parts.)

IMPORTANT SAFETY INSTRUCTIONS

When using an battery powered appliance, basic precaution must always be followed, including the following:

READ ALL INSTRUCTIONS BEFORE USING THIS MACHINE.



To reduce the risk of fire, electric shock, or injury:

Use only indoors. Do not use outdoors or expose to rain.

Use only as described in this manual. Use only manufacturer's recommended components and attachments.

If the machine is **not working properly**, has been dropped, damaged, left outdoors, or dropped into water, return it to an authorized service center.

Do not operate the machine with any openings blocked. Keep openings free of debris that may reduce airflow.

This machine is **not** suitable for picking up hazardous dust.

Machine can cause a fire when operating near flammable vapors or materials. Do not operate this machine near flammable fluids, dust or vapors.

This machine is suitable for commercial use, for example in hotels, schools, hospitals, factories, shops and offices for more than normal housekeeping purposes.

Maintenance and repairs **must be done** by qualified personnel.

If foam or liquid comes out of machine, **switch off immediately.**

Disconnect battery before cleaning or servicing.

Before the machine is discarded, the batteries **must be removed** and properly disposed of.

Make sure all warning and caution labels are **legible and properly attached** to the machine.

During operation, attention shall be paid to other persons, especially children.

Before use all covers and doors shall be put in the positions specified in the instructions.

When leaving unattended, secure against unintentional movement.

The machine shall only be operated by instructed and authorized persons.

When leaving unattended, switch off or lock the main power switch to prevent unauthorized use.

Only chemicals recommended by the manufacturer shall be used.

This appliance has been designed for use with the brushes specified by the manufacturer. The fitting of other brushes may affect its safety.

Do not use on surfaces having a gradient exceeding 2% unless the optional parking brake is installed on the machine.

SAVE THESE INSTRUCTIONS

HAZARD INTENSITY LEVEL

The following symbols are used throughout this guide as indicated in their descriptions:

HAZARD INTENSITY LEVEL

There are three levels of hazard intensity identified by signal words **-WARNING** and **CAUTION** and **FOR SAFETY**. The level of hazard intensity is determined by the following definitions:

▲ WARNING

WARNING - Hazards or unsafe practices which **COULD** result in severe personal injury or death.

▲ CAUTION

CAUTION - Hazards or unsafe practices which could result in minor personal injury or product or property damage.

FOR SAFETY: To identify actions which must be followed for safe operation of equipment.

Report machine damage or faulty operation immediately. Do not use the machine if it is not in proper operating condition. Following is information that signals some potentially dangerous conditions to the operator or the equipment. Read this information carefully. Know when these conditions can exist. Locate all safety devices on the machine. Please take the necessary steps to train the machine operating personnel.

FOR SAFETY:

DO NOT OPERATE MACHINE:

Unless Trained and Authorized.

Unless Operation Guide is Read and understood.

In Flammable or Explosive areas.

In areas with possible falling objects.

WHEN SERVICING MACHINE:

Avoid moving parts. Do not wear loose clothing; jackets, shirts, or sleeves when working on the machine. Use manufacturer approved replacement parts.

▲ WARNING

Batteries emit hydrogen gas. Explosion or fire can result. Keep sparks and open flame away. Keep solution tank in raised position when charging. Keep sparks and flames away from the batteries. Do not smoke around batteries.

▲ WARNING

Disconnect batteries before working on machine. Only qualified personnel should work inside machine. Always wear eye protection and protective clothing when working on or near batteries. Avoid skin contact with the acid contained in the batteries.

▲ WARNING

Never allow metal to lie across battery tops.

SAFETY LABEL LOCATION

NOTE: These drawings indicate the location of safety labels on the WATCHMAN™. If at any time the labels become illegible, promptly replace them.



SAFETY DECAL 81494

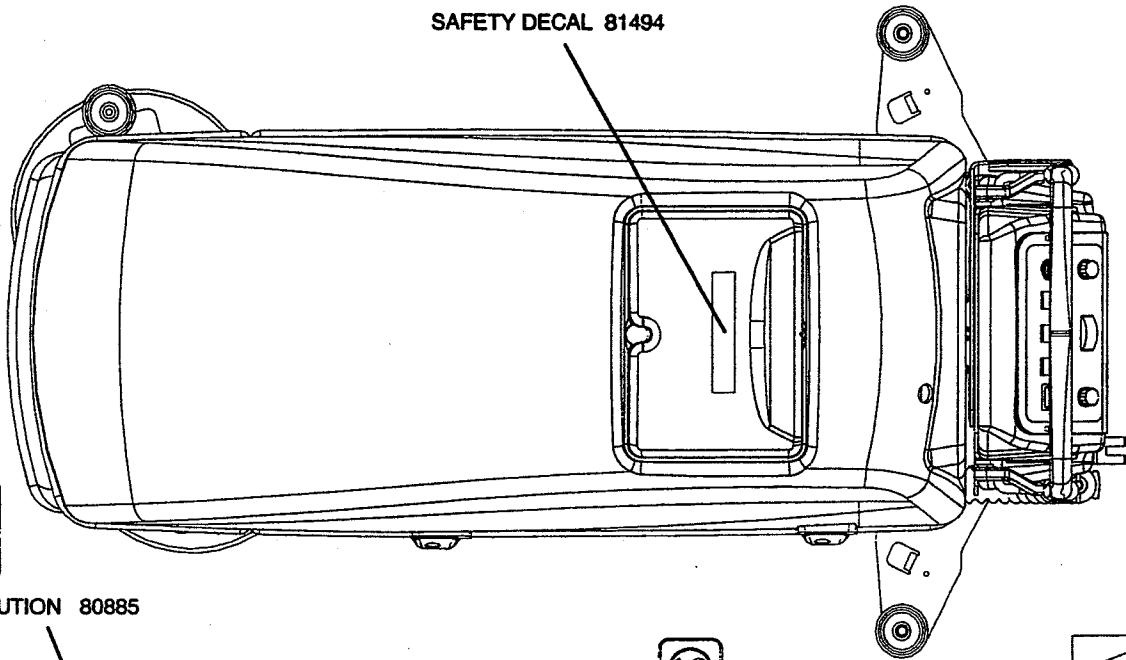

BATTERY CAUTION 80885



MANUAL DECAL 50776

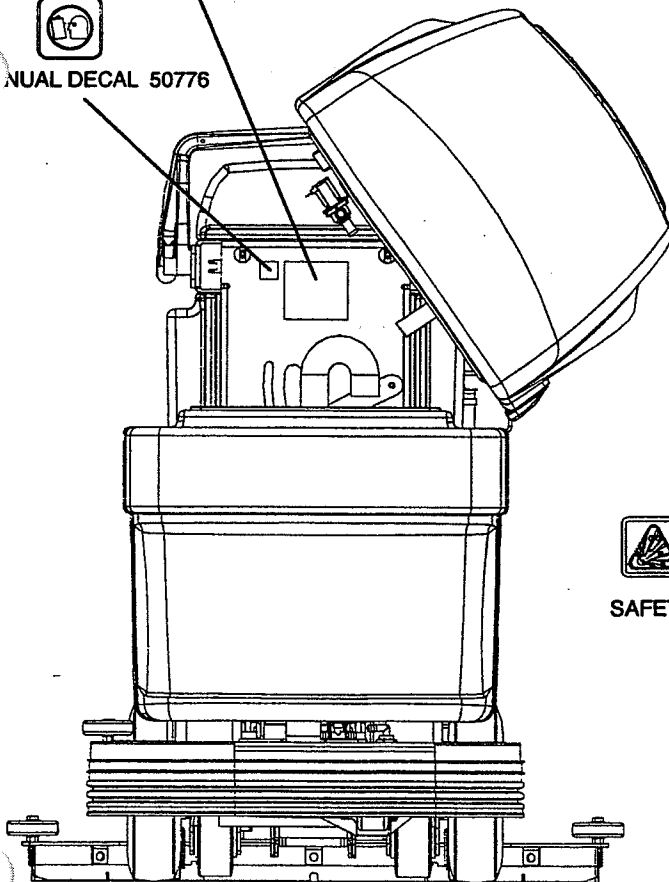

MANUAL DECAL 50776

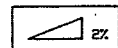

2% GRADE DECAL 50926

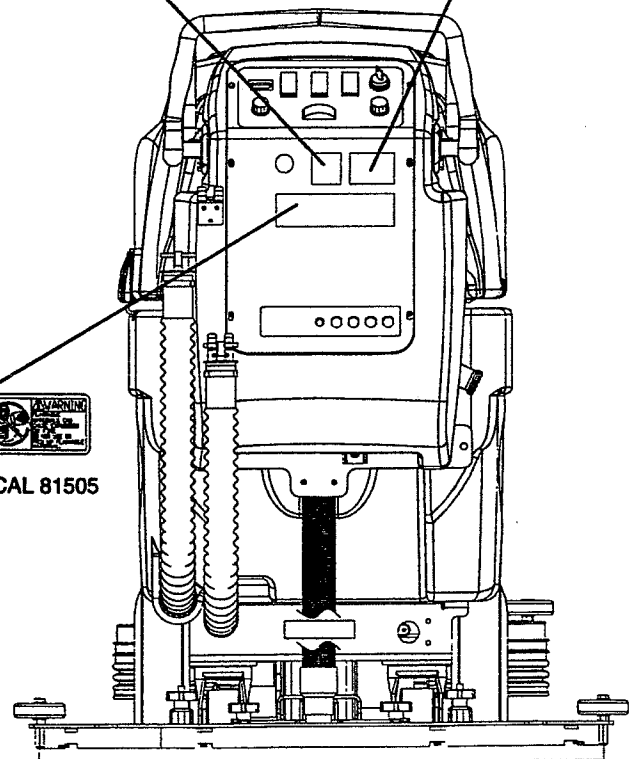

SAFETY DECAL 81505

TECHNICAL SPECIFICATIONS

ITEM	DIMENSION/CAPACITY
Nominal power	1.44 kW
Rated Voltage	24VDC
Rated Amperage	60 Amps
Batteries	4 X 6 Volt 250-305 AH @ 20 hr rate
Scrub Brush Motors	2 X .75 hp (0.56 Kw)
Vacuum Motor	.75 hp (0.56 Kw)
Propelling Motor	.3 hp (0.22 Kw)
Mass (GVW)	1050 lbs. (480 kg)
Weight empty without batteries	425 lbs. (192 kg)
Solution Control	Gravity feed, fully variable with automatic shut-off in neutral
Solution tank capacity	21 gal. (79.5 l)
Recovery tank capacity	21 gal. (79.5 l)
Scrub brush diameter for 24 in. (61cm) scrub head	12 in (30.5 cm)
Scrub brush diameter for 26 in. (66 cm) scrub head	13 in (33.0 cm)
Scrub brush diameter for 28 in. (71 cm) scrub head	14 in (35.5 cm)
Scrub brush pressure	0-150 lbs. (0-68 kg)
Scrub brush speed	200 rpm
Tires	2 x 10 in (25.4 cm) pneumatic non-marking standard
Casters	2 X 4 in (10.2 cm) polyurethane solid non-marking
Foundation Pressure (at recommended tire psi)	32 lbs./in ² (225 kPa)
Maximum Speed	3.2 Miles/hour (5.2 km/hour)
Coverage with 24 in. (61 cm) scrub head	29,040 ft ² /hour at 3.0 mph with 2 in. overlap
Coverage with 26 in. (66 cm) scrub head	31,680 ft ² /hour at 3.0 mph with 2 in. overlap
Coverage with 28 in. (71 cm) scrub head	34,320 ft ² /hour at 3.0 mph with 2 in. overlap
Frame Construction	Welded cold rolled steel and steel plate with epoxy powdercoat finish.
Brakes (optional)	Tire lock parking brake, foot activated
Minimum aisle u-turn width with 24 in. (61 cm) scrub head	65 in. (165 cm)
Minimum aisle u-turn width with 26 in. (66 cm) scrub head	65.5 in. (166 cm)
Minimum aisle u-turn width with 28 in. (71 cm) scrub head	66 in. (168 cm)
Maximum rated climb and descent angle with empty tanks and without optional parking brake	2%
Maximum rated climb and descent angle with full tanks and without optional parking brake	2%

TECHNICAL SPECIFICATIONS

ITEM	MEASURE
Height	43.5 in. (110 cm)
Length with 24 in. (61 cm) scrub head	64 in. (163 cm)
Length with 26 in. (66 cm) scrub head	64.5 in. (164 cm)
Length with 28 in. (71 cm) scrub head	65 in. (165 cm)
Width without squeegee and scrub head	22 in. (56 cm)
Width of squeegee for 24 in. (61 cm) scrub head	36 in. (91 cm)
Width of squeegee for 26 in. (66 cm) scrub head	36 in. (91 cm)
Width of squeegee for 28 in. (71 cm) scrub head	39.5 in. (100 cm)
Width of scrub path for 24 in. (61 cm) scrub head	24 in. (61 cm)
Width of scrub path for 26 in. (66 cm) scrub head	26 in. (66 cm)
Width of scrub path for 28 in. (71 cm) scrub head	28 in. (71 cm)

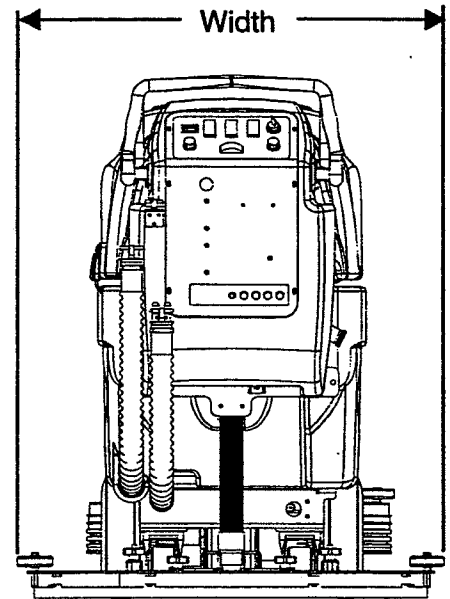
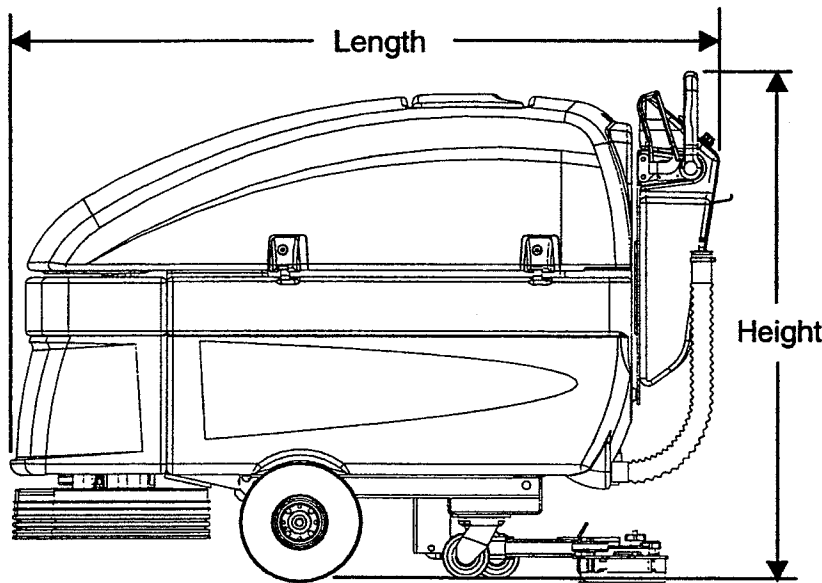

SPECIAL NOTES:

The sound pressure level at the operator's ear was measured to be 68 dBA. This was a nearfield, broad-band measurement taken in a typical industrial environment on a tile floor. This appliance contains no possible source of impact noise. The instantaneous sound pressure level is below 63 Pa.

The weighted root mean square acceleration at the operator's arms was measured to be below 2.5m/s^2 . This was a tri-axial, third-octave-band measurement made during normal operation on a composite tile floor. The measurement and related calculations were made in accordance with ANSI S3.34-1986.

HOW THE MACHINE WORKS

The *WATCHMAN™* is a battery powered, self-propelled, hard floor scrubber intended for commercial use. The appliance applies a cleaning solution onto a hard floor, scrubs the floor with brushes, and then vacuums the soiled water back into the recovery tank.

The machines primary systems are the solution system, scrub system, recovery system, and directional control system.

The function of the solution system is to store cleaning solution and deliver it to the scrub system. The solution system consists of the solution tank, strainer, valve and controls. The solution tank stores cleaning solution (water and detergent) until it is delivered to the scrub system. The strainer protects the valve from debris. The valve is a solenoid type valve, which controls the delivery of cleaning solution to the scrub system. The valve automatically prevents solution flow unless the scrub brushes are turned on and the machine is being propelled. The solution control knob controls the amount of cleaning solution delivered to the scrub system by controlling the amount of time the valve is open.

The function of the scrub system is to scrub the floor. The scrub system consists of two rotary type disk scrub brushes, motors, self-adjusting scrub deck skirt, lift actuator and controls. The brushes scrub the floor and the motors drive the brushes. The brush drive hubs allow the scrub brushes to follow irregularities and changes in the floor without losing contact with floor. The self-adjusting scrub deck skirt controls the cleaning solution on the floor so that the squeegee can pick it up. The brush pressure switch controls an actuator, which raises and lowers the scrub deck. The brush pressure indicator corresponds to the amp draw of the scrub brush motors to tell how hard they are working.

The function of the recovery system is to vacuum the soiled water back into the recovery tank. The recovery system consists of the squeegee, vacuum motor, filter, recovery tank and controls. The squeegee wipes the dirty solution off the floor as the machine moves forward. The vacuum motor provides suction to draw the dirty solution off the floor and into the recovery tank. The filter protects the vacuum fan from debris and foam. The recovery tank stores the dirty solution. The float switch in the tank activates the recovery tank full indicator and shuts off the vacuum motor.

The function of the directional control system is to control the direction and speed of the machine. The directional control system consists of the directional control lever, switches, speed control knob/potentiometer, controller and transaxle. The directional control lever actuates switches, which signal forward or reverse. The speed control knob actuates a potentiometer, which signals speed. The controller interprets the forward/reverse signals from the switches and the speed signal from the potentiometer to command the transaxle to propel the machine in the direction, and at the speed, desired.

CONTROLS

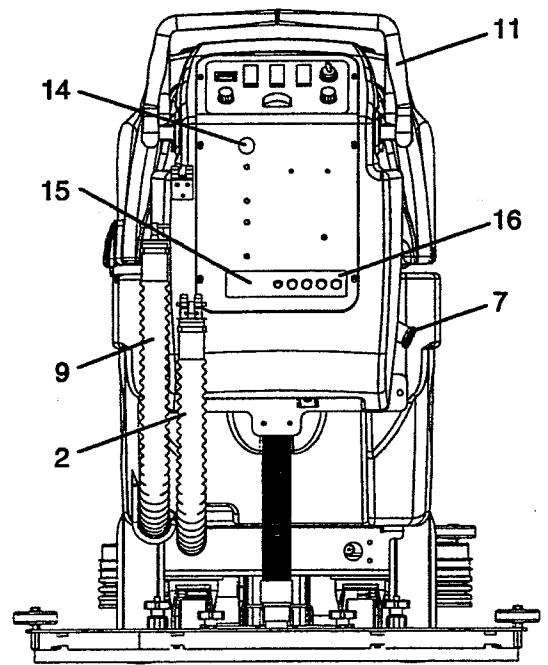
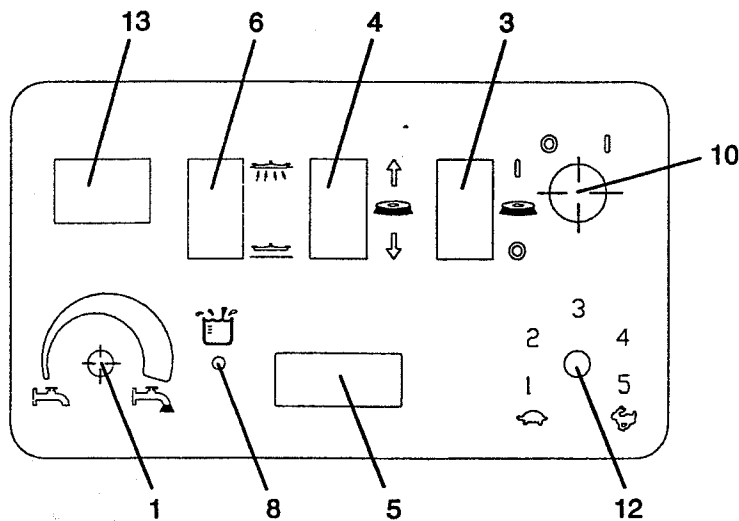

1. **Solution Control Knob**
2. **Solution Tank Drain Hose**
3. **Brush Switch**
4. **Brush Pressure Switch**
5. **Brush Pressure Indicator**
6. **Vacuum Switch**
7. **Squeegee Lift Lever**
8. **Recovery Tank Full Indicator**
9. **Recovery Tank Drain Hose**
10. **Key Switch**
11. **Direction Control Lever**
12. **Speed Control Knob**
13. **Battery Charge Level Indicator**
14. **Emergency Shut Off Switch (Optional)**
15. **Hour Meter (Optional)**
16. **Circuit Breakers**

CONTROLS

- 1. SOLUTION CONTROL KNOB**

Controls solution flow to scrub deck. Rotate the knob clockwise to increase flow. Rotate the knob counterclockwise to decrease flow. If the brush motors are turned off of the direction control lever is in neutral, the flow is automatically interrupted until the motors are turned on again. This feature prevents unintentional draining of the solution tank and allows the operator to adjust the solution flow to the scrub deck without resetting each time the scrubbing operation is interrupted.
- 2. SOLUTION TANK DRAIN HOSE**

Located at left rear of machine. Secured by clip and closed by expanding plug.
- 3. BRUSH SWITCH**

Turns the scrub motors on and off. Press the top of the switch to turn on. Press the bottom of the switch to turn off. The brushes will not rotate with the direction control lever in neutral.
- 4. BRUSH PRESSURE SWITCH**

Adjusts the amount of brush pressure to the floor by raising or lowering the scrub deck. Press the bottom of the switch to increase brush pressure. Press the top of the switch to decrease brush pressure or raise the scrub deck.
- 5. BRUSH PRESSURE INDICATOR**

The brush pressure indicator corresponds to the amp draw of the scrub brush motors to tell how hard the motors are working. The green zone indicates proper operating brush pressure. The red zone indicates excessive brush pressure. Operating in the red zone will cause the brush circuit breakers to trip.
- 6. VACUUM SWITCH**

Turns the vacuum motor on and off. Press the top of the switch to turn on. Press the bottom of the switch to turn off. The vacuum motor will not operate with the recovery tank full indicator light on.
- 7. SQUEEGEE LIFT LEVER**

Raises and lowers the squeegee. Lift the handle from its raised position to lower the squeegee. Lift the handle from its lowered position to raise the squeegee.
- 8. RECOVERY TANK FULL INDICATOR**

Will light when the float switch indicates a full recovery tank. The vacuum motor will not operate with recovery tank full. The recovery tank must be drained and the vacuum switch or key switch turned off before the indicator light will turn off.
- 9. RECOVERY TANK DRAIN HOSE**

Located at left rear of machine. Secured by clip and closed by expanding plug.
- 10. KEY SWITCH**

Controls the power for machine functions. Rotate the key clockwise to turn on the machine. Rotate the key counterclockwise to turn off the machine.

FOR SAFETY: Always remove the key when machine is unattended or during service to prevent unauthorized movement.
- 11. DIRECTION CONTROL LEVER**

Controls the machine direction, and scrub brushes and solution flow. Push the lever forward to propel the machine forward. Pull the lever toward you to propel the machine backward. The scrub brushes will not rotate and the solution will not flow to scrub deck with the direction control lever in neutral.
- 12. SPEED CONTROL KNOB**

Controls the speed of the machine. Rotate the knob clockwise to increase speed. Rotate the knob counterclockwise to decrease speed.
- 13. BATTERY CONDITION METER**

The battery condition meter indicates the charge level of the battery. The meter display is divided into 10 vertical bars. Bars illuminated on the far right indicate full charge. Bars flashing near the left side indicate the batteries should be recharged. Further operation of the machine could damage the machine or the batteries.

When the machine is left overnight with less than a full charge, the display may initially indicate a full charge. It will also indicate a full charge if the batteries are disconnected, then reconnected. After a few minutes of operation the meter will give the correct charge level.

14. EMERGENCY SHUT-OFF SWITCH (OPTIONAL)

Shuts off machine. Push the switch to shut off machine. Rotate the switch clockwise to restart machine.

15. HOUR METER (OPTIONAL)

Records the number of hours the machine has been in operation. This information is useful in determining when to service the machine.

16. CIRCUIT BREAKERS

Circuit breakers interrupt the flow of power in the event of an electrical overload. When a circuit breaker is tripped, reset it by pressing the exposed button. If a circuit breaker continues to trip, the cause of the electrical overload should be found and corrected.



3 Amp. Protects the machine controls and scrub deck lift actuator.



30 Amp. Protects the left scrub brush motor.



30 Amp. Protects the right scrub brush motor.



25 Amp. Protects the vacuum motor.



25 Amp. Protects the propel motor.

MACHINE OPERATION

PRE-RUN MACHINE INSPECTION

Do a pre-run inspection to find possible problems that could cause poor performance or lost time from breakdown. Follow the same procedure each time to avoid missing steps.

NOTE: See maintenance section for pre-run machine inspection checklist items.

STARTING MACHINE

NOTE: Perform pre-run machine check before operating machine.

FOR SAFETY: Before starting machine, make sure that all safety devices are in place and operating properly.

1. Turn the machine power on.
2. Release the parking brake, if your machine is equipped with this option.
3. Move the direction control lever in the desired direction.

EMERGENCY STOP PROCEDURES

1. Release the directional control lever.
2. Turn machine power off with key switch.
3. If an electrical problem is suspected push in emergency stop button, if machine is equipped with this option.
4. Apply brakes, if your machine is equipped with this option.

FILLING SOLUTION TANK

FOR SAFETY: Before leaving or servicing machine; stop on level surface, turn off machine and remove key.

1. Turn the machine power off.
2. Set the parking brake if your machine is equipped with this option.
3. Remove solution tank cover.
4. Fill the solution tank with clean water, leaving enough room for the required amount of cleaning solution. The solution tank capacity filled to 5" (13cm) from bottom of fill inlet is 21 gallons (79.5 liters). The water must not be hotter than 140° F (60°C) to prevent damage to the tank.

5. **Measure** the chemical into the solution tank. Liquid chemicals should be added to the solution tank after filling with water. Dry chemicals should be thoroughly mixed before being added into solution tank. Commercially available, high alkaline floor cleaners, are suitable for use in the solution system.

NOTE: Read the chemical manufacturers recommended proportion instructions.

6. Replace solution tank cover.

WARNING

Flammable materials can cause an explosion or fire. Do not use flammable materials in the tanks.

NORMAL SCRUBBING

Plan the scrubbing pattern in advance. The longest track is around the perimeter of the area to be cleaned. For efficient operation, the runs should be the longest possible without turning, stopping, or raising and lowering scrub deck/squeegee.

NOTE: In order to achieve the best possible results, the area which is to be cleaned should be swept before scrubbing. Large debris, strings & wire must be removed to prevent being caught in brushes or squeegee.

INEFFICIENT SCRUBBING PATH

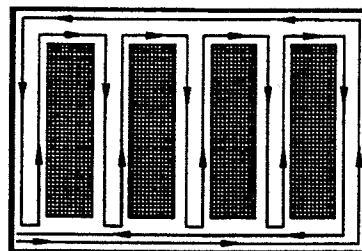

RECOMMENDED SCRUBBING PATH

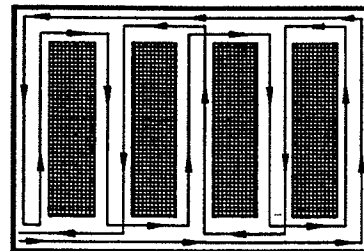

TO BEGIN SCRUBBING

▲ CAUTION

When operating the machine around people, pay close attention for unexpected movement. Use extra caution around children.

▲ WARNING

Flammable liquids and/or reactive metals can cause explosions or fire! Do not pick up.

1. Turn the machine power on.
2. Lower the squeegee.
3. Turn the vacuum on.
4. Lower the scrub brushes to the floor.
5. Turn the scrub brushes on (brushes will start when machine is propelled).
6. Drive machine forward to begin scrubbing.
NOTE: Shut machine off immediately if water or foam is expelled from the machine.
7. Adjust the speed of the machine, solution flow and scrub brush pressure as necessary.
NOTE: Once solution flow rate is set it is not necessary to shut off solution when stopping scrubbing. Solution flow is automatically shut off when brush motors stop. When brush motors are activated, flow automatically resumes.

TO STOP SCRUBBING

1. Release the directional control lever.
2. Turn the scrub brushes off.
3. Raise the scrub brushes.
4. Raise the squeegee.
5. Turn the vacuum off.
6. Turn the machine power off.

DOUBLE SCRUB

Floors which are heavily soiled or have thick accumulations of floor finish may not clean sufficiently with one pass. In these cases it will be necessary to double scrub.

To double scrub, make the first pass over the surface being cleaned with the squeegee up, the solution on, and brushes down. This allows the solution to stay in contact with the soil while loosening the surface accumulation with the brushes. Allow time for the first application to stay in contact with the floor. Length of time between the

first and second pass depends on amount of accumulation and the type of chemical being used. A second scrubbing with the squeegee down and again the solution and brushes on will further loosen soil. The additional application of solution will further assist the difficult cleaning job.

FOR SAFETY: When using machine, go slow on inclines and slippery services.

EMPTYING AND CLEANING TANKS

1. Park the machine next to a floor drain. Drain hose is on left rear corner of the machine.
2. Turn the machine power off and set parking brake, if your machine is equipped with this option.

SOLUTION TANK

1. Unhook the small drain hose from the retainer. Unscrew T-handle on plug enough to loosen plug, then lower hose in direction of the drain. Slowly remove plug from drain hose.
2. Remove the solution tank cover.
3. Flush the solution tank out with clean water and run several gallons of clean water through systems. Do not use water hotter than 140°F (60°C) to clean tank. Damage may occur.
NOTE: Never allow solution to remain in tank. Damage to tank, seals and valves could occur.
4. Replace the drain plug and secure drain hose in bracket.

RECOVERY TANK

1. Unhook the large drain hose from the retainer. Unscrew the T-handle on plug enough to loosen plug, then lower hose in direction of the drain. Do not stand in front of end of hose. Recovered solution will come out with force. Slowly remove plug from drain hose.
2. Raise solution tank to access recovery tank. Make sure the support arm is fully engaged. Flush the recovery tank out with clean water. Do not use water hotter than 140°F (60°C) to clean tank. Damage may occur.
3. Clean off the float switch and check for free movement of float. The float switch is located in the front of the recovery tank.
4. Replace the drain plug and secure drain hose in bracket.
5. If machine is to be stored, leave solution tank in raised position.

MAINTENANCE

BATTERIES

The batteries provide the power to operate the machine. The batteries require regular maintenance to keep them operating at peak efficiency.

The machine batteries will hold their charge for long periods of time, but they can only be charged a certain number of times. To get the greatest life from the batteries, charge them when their charge level reaches 25% of a full charge. Use a hydrometer to check the charge level.

Do not allow the batteries to remain in a discharged condition for any length of time. Never expose a discharged battery to temperatures below freezing. Discharged batteries will freeze causing cracked cases. Do not operate the machine if the batteries are in poor condition or if they have a charge level below 25% (specific gravity below 1.155).

Keep all metallic objects off the top of the batteries, as they may cause a short circuit. Replace worn or damaged cables and terminals.

Check the electrolyte level in each battery cell before and after charging the batteries. Never add acid to the batteries, use distilled water. Do not allow water level to fall below the battery plates. Portions of plates exposed to air will be destroyed. Do not overfill. Keep plugs firmly in place at all times.

⚠ CAUTION

When servicing machine, avoid contact with battery acid.

⚠ WARNING

Batteries emit hydrogen gas. Explosion or fire can result. Keep sparks and open flame away. Keep covers open when charging.

⚠ WARNING

Wear eye protection and protective clothing when working with batteries.

⚠ WARNING

Charge batteries in a well ventilated area.

BATTERY MAINTENANCE

1. When cleaning the batteries, use a solution of baking soda and water. Do not allow the cleaning fluid to enter the battery cells, electrolyte will be neutralized.
2. Maintain the proper electrolyte level in each battery cell. If a cell should accidentally overflow, clean immediately.

3. Wipe off the top of the batteries at least once a week.
4. Test battery condition with a hydrometer at least once a week.
5. Ensure that all connections are tight and all corrosion removed.
6. Every 4 to 6 months, remove that batteries from the machine and clean the battery cases and battery compartment.

CHECKING BATTERY SPECIFIC GRAVITY

Use a hydrometer to check the battery specific gravity.

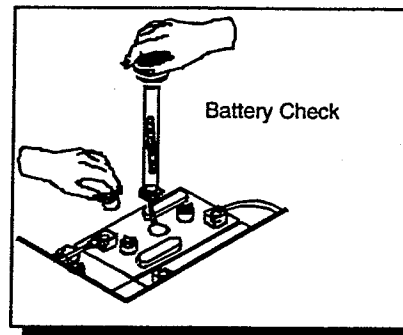

CHECKING GRAVITY

A. Hydrometer

B. Battery

NOTE: Do not take readings immediately after adding distilled water, if the water and acid are not thoroughly mixed, the reading may not be accurate.

Check the hydrometer readings against this chart.

SPECIFIC GRAVITY @ 80° F (27°C)	BATTERY CONDITION
1.265	100% CHARGED
1.225	75% CHARGED
1.190	50% CHARGED
1.155	25% CHARGED
1.120	DISCHARGED

NOTE: If the readings are taken when the battery electrolyte is any temperature other than 80° F (27°C), the reading must be temperature corrected.

To find the corrected specific gravity reading when the temperature of the battery electrolyte is other than 80°F (27°): Add (+) to the specific gravity reading 0.004 (4 points), for each 10°F (6°C) above 80° (27°C).

Subtract (-) from the specific reading 0.004 (4 points), for each 10°F (6°C) below 80°F (27°C).

TO CHARGE THE BATTERIES

⚠ CAUTION

When servicing machine, avoid contact with battery acid.

⚠ WARNING

Batteries emit hydrogen gas. Explosion or fire can result. Keep sparks and open flame away. Keep covers open when charging.

⚠ WARNING

Wear eye protection and protective clothing when working with batteries.

⚠ WARNING

Charge batteries in a well ventilated area. Leave the solution tank open.

Use a 24 volt, 20 amp maximum output, DC charger which will automatically shut off when the batteries are fully charged to charge the four battery pack.

1. Stop the machine in a clean, well ventilated area next to the charger.
2. Turn "OFF" machine.

FOR SAFETY: Before leaving or servicing machine; stop on level surface, turn off machine and remove key.

3. Drain solution tank and raise the solution tank and lock the support arm. Make sure the support arm is fully engaged.

⚠ WARNING

Batteries emit hydrogen gas. Explosion or fire can result. Keep sparks and open flame away. Keep covers open when charging.

4. Check the electrolyte level in each battery cell. Before charging, add just enough distilled water to cover the plates. After charging is complete, add just enough distilled water to bring up the level to the indicator ring. If the water level is too high before charging, normal expansion rate of the electrolyte may cause an overflow. Resulting in a loss of battery acid balance and damage the machine.
5. Replace the battery caps, and leave them in place while charging.
6. Unplug the battery connector from the machine.

FOR SAFETY: When charging, connect the charger to the batteries before connecting the charger to the AC wall outlet. Never connect the charger to the AC wall outlet first. Hazardous sparks may result.

7. Plug the charger connector into the battery connector. Connect the charger AC plug to a wall outlet. The charger gauge should indicate that the batteries are charging.
8. When the batteries are fully charged, disconnect the charger from the AC wall outlet, then disconnect the charger from the batteries.
9. Connect the batteries to the machine connector.
10. Check the electrolyte level. It should be up to the indicator ring. If necessary, add distilled water.
11. Lower the solution tank.

CHANGING BATTERIES

Stop the machine in a clean area next to the charger. Turn off machine.

FOR SAFETY: Before leaving or servicing the machine; stop on level surface, turn off machine and remove key.

1. Raise the solution tank.
2. Engage solution tank support arm.
3. Disconnect battery pack from machine.
4. Use the proper size open end wrench to disconnect main ground wire first and secure cable terminal away from batteries.
5. Disconnect main positive lead and secure cable terminals away from batteries.
6. Loosen both terminals on each jumper cable and remove one at a time.
7. Prepare a suitable site to place the batteries.
8. Attach suitable battery lifting device and lift batteries from the machine.

⚠ WARNING

Batteries are a potential environmental hazard. Consult your battery supplier for safe disposal methods.

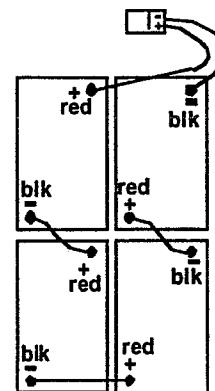

MAINTENANCE

SCRUB BRUSHES

NOTE: All original equipment brushes are equipped with "Perform Alert®". This feature will tell the operator when it is time to replace the scrub brushes. "Perform Alert®" brushes have pre-trimmed bright yellow tufts to indicate the length of a worn out brush. When the tufts in the scrub brush wear to a length equal to the yellow tufts, the scrub brushes should be replaced.

There are five different types of brushes available to cover applications from cleaning heavily soiled floors to polishing. A pad driver is also available to take advantage of the many cleaning pads on the market and further add to the flexibility of the BETCO. Please refer to the following to assist in selecting the proper brush or pad for the work at hand.

UNCOATED FLOORS

Aggressive Grit is a nylon fiber impregnated with silicone carbide grit. It grinds away stain, soil, and removes surface material.

Mild Grit is a less aggressive silicone carbide grit suitable for cleaning medium soil conditions. Advantages are faster ground speed than nylon bristles on light solid applications.

Nylon is a general-purpose scrub brush with stiff bristles. Polypropylene works well for maintaining concrete, wood and tile floors.

FINISHED FLOORS

Nylon Polish is the softest brush. It will gently clean finished tile or terrazzo floors without removing floor finish or floor material. Used for washing highly polished or burnished floors.

Nylon bristles are used in a variety of applications on coated or uncoated surfaces.

White Pads (Polishing) are used for dry polishing to achieve a high-gloss appearance, or surface washing on highly polished or burnished floors.

Red Pads (Buffing) are used for light-duty scrubbing. When used with a mild detergent they will provide surface cleaning without removing the finish.

Blue Pads (Scrubbing) are used for heavy-duty scrubbing and light stripping. The blue pads remove less finish than brown stripping pads, yet will remove black marks, stains and dirt.

Brown Pads (Stripping) are used for easy and complete removal of old floor waxes/finishes. They will quickly remove ground in dirt, black heel marks, and spills. When used with the proper stripper, this pad leaves the floor clean and ready for finishing.

The scrub brushes should be checked before each days work for wire, string, wear and damage. The scrub brushes should be replaced if brush bristles are missing or if yellow Perform Alert © indicates minimum brush length.

REPLACING OR INSTALLING SCRUB BRUSHES

1. With the scrub deck up, turn "OFF" the machine.

FOR SAFETY: Before leaving or servicing the machine; stop on level surface, turn OFF machine and remove key.

2. Locate release lever on top of brush or pad driver. Rotate release lever counter-clockwise and the brush/pad driver will release and drop down.
3. To reinstall, center the brush driver under the brush drive hub. Raise until it contacts brush driver assembly. Turn clockwise until release lever plate locks into position.

NOTE: Check that release plate is completely closed and pad/brush is securely attached. Damage to driver or brush could occur.

4. Repeat the procedure for the opposite side of machine.

SQUEEGEE BLADES

The front squeegee blade allows solution to pass through channels in the blade into the squeegee assembly while maintaining vacuum to provide lift. The front blade has four wear surfaces and can be rotated for extended life. There are three different notch patterns and three different colors of squeegees for varying floor conditions. The red blade has the most notches and is for normal, smooth surfaces. The blue blade has less notches and is for rougher or tiled surfaces. The green blade has no notches and is for rough surfaces such as knobby tile or uneven tile. The linatex blades are used for industrial settings. The front blade should not require regular replacement under normal use.

The rear blade wipes the floor to a near dry condition. It is important the rear blade be in good condition to properly do its job. As with the front blades there are 4 rear blade options; red, blue, green and linatex. Front and rear blades should be color matched. Each squeegee blade assembly has four wear surfaces for extended service.

Check both the front and rear squeegee blades for damage, wear, and adjustment each day in the pre-run check. Change the front blade if it is torn or has an uneven edge. Change the rear blade if it is less than 1/2 the original thickness.

ADJUSTING SQUEEGEE

Adjusting the squeegee is a two-part process. First, the squeegee assembly must have correct pitch in order for the squeegee blade to have the same deflection at each tip as well as the center. The knob on the squeegee linkage controls the pitch adjustment. The second adjustment is the deflection. Knobs on each end of the squeegee control the Standard Squeegee Assembly adjustment. A color-coded slide bar controls the Smart Squeegee Option adjustment according to the type of floor and squeegee blade employed.

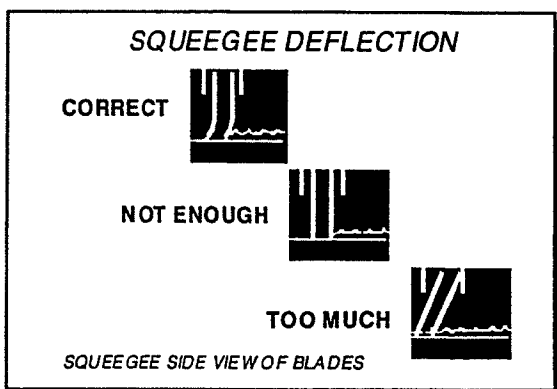

TO REMOVE SQUEEGEE ASSEMBLY

1. With the squeegee in the up position, turn key switch "OFF".
2. Disconnect vacuum hose from squeegee and loosen both knobs.
3. Pull squeegee assembly rearward from the lifting carrier.
4. Inspect or repair as necessary and reinstall.

TO REPLACE OR ROTATE REAR SQUEEGEE BLADES

1. With the squeegee in the up position, turn key switch "OFF".

FOR SAFETY: Before leaving or servicing machine; stop on level surface, turn off machine and remove key.

2. Remove the squeegee assembly from the machine. Unlatch and remove blade retainer strap and remove squeegee blade.
3. Rotate the squeegee to new edge position or replace as required. Each blade has four new edge positions.
4. Install blade on locating pins of squeegee assembly.
5. Install squeegee retainer strap.
6. For Smart Squeegee Option Only: Fasten and lock latch, adjust latch only tight enough to take up slack in retaining strap.

TO REPLACE OR ROTATE FRONT SQUEEGEE BLADE – STANDARD SQUEEGEE ASSEMBLY ONLY

1. With the squeegee in the up position, turn key switch "OFF".
2. Remove the squeegee from the machine. Loosen three thumbscrews and remove the retainer strap and squeegee blade.
3. Rotate the squeegee to new edge position or replace as required. Each blade has four new edge positions. When installing the front blade, tighten the center thumbscrew first. Insure that the retainer strap is pressed against the blade before tightening the outer screws.

MAINTENANCE

TO REPLACE OR ROTATE FRONT SQUEEGEE BLADE – SMART SQUEEGEE OPTION ONLY

1. With the squeegee in the up position, turn key switch "OFF".
2. Remove the squeegee from the machine. Release latch securing retainer strap.
3. Remove front retainer strap.
4. Remove squeegee blade from locating pins on squeegee assembly and rotate to new position or replace as required.
5. Install blade on locating pins of squeegee tool.
6. Replace front retainer strap.
7. Secure strap by locking latch.

TO ADJUST SQUEEGEE PITCH

1. Choose a smooth, level surface. Turn "ON" the key switch. Lower the squeegee and drive forward at least 2 feet (60cm.).
2. With the squeegee down, stop the machine. Do not allow machine to roll back.

FOR SAFETY: Before leaving or servicing the machine; stop on level surface, turn off machine and remove key.

3. Determine the differences, if any, in deflection of the squeegee blade between each end and the middle. Proper adjustment is obtained when deflection is equal all the way across the squeegee blade.
4. To decrease the deflection of the squeegee blade at the ends, loosen plastic knob near the squeegee center. To increase the deflection at the ends of the squeegee assembly, tighten plastic knob.
5. Check the deflection of the squeegee blades again. Repeat steps 1 through 4 until the deflection is equal across the entire rear squeegee blade.

TO ADJUST AMOUNT OF REAR SQUEEGEE DEFLECTION

1. Choose a smooth, level surface. Lower the squeegee and drive forward at least 2 feet.
2. With the squeegee down, stop the machine. Do not allow machine to roll back.

FOR SAFETY: Before leaving or servicing machine; stop on level surface, turn off machine and remove key.

3. Observe the amount of squeegee deflection. It should deflect 3/8 in. (9.5mm) across the entire width of the squeegee.
4. To increase the squeegee deflection, turn the 2 knobs at the squeegee ends CCW. To decrease the deflection, turn the knob CW.

NOTE: The deflection should be consistent along the length of the squeegee. If the deflection varies from end to end the knobs can be adjusted independently to correct the variation.

5. Turn on the key switch. Raise, then lower squeegee assembly. Drive forward at least 2 feet.
6. Repeat steps 2 through 4 until deflection of 3/8 in. (9.5mm) is reached.

SCRUB DECK SKIRT AND SQUEEGEE

The skirts and squeegee should be inspected for wear and damage. The skirt is self-adjusting. Replace skirt when they become cracked, worn, torn or brittle.

TIRES AND WHEELS

Check for low or worn tires. Fill to proper pressure as needed (50psi). Check wheel nuts for tightness, tighten as necessary.

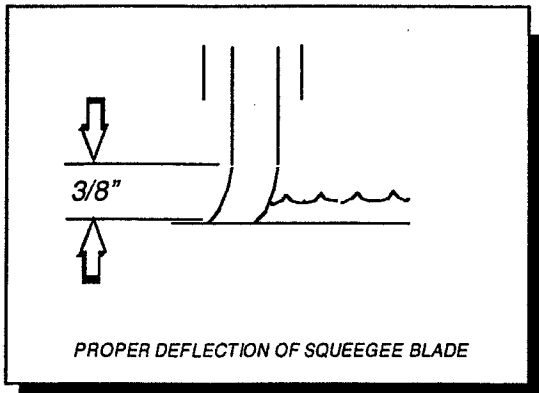

SERVICE SCHEDULE

*before
starting
the work
period*

*End of
work
period
before
storing*

MAINTENANCE	DAILY	WEEKLY	MONTHLY	ANNUALLY
Check battery acid level	*			
Check vac hose connections	*			
Clean the squeegee blades	*			
Inspect brushes or pads for debris: wire string, wear	*			
Inspect vac fan shut off float screen	*			
Drain & rinse tanks	*			
Raise squeegee assembly	*			
Raise scrub deck assembly	*			
Charge the batteries.	*			
Remove the pad drivers/brushes	*			
Check the brushes/pads for damage and/or wear	*			
Clean squeegee blades.	*			
Clean recovery tank shut off & screen	*			
Check battery cells w/ hydrometer		*		
Check solution strainer		*		
Check pivot points, caster and squeegee for proper lubrication		*		
Inspect tank and hoses		*		
Clean tops of batteries and tray			*	
Check battery cable clamps			*	
Use a vacuum to remove lint from the motor windings			*	
Grease casters			*	
Inspect all motors for carbon motor brush wear				*

CONTROL HANDLE GROUP

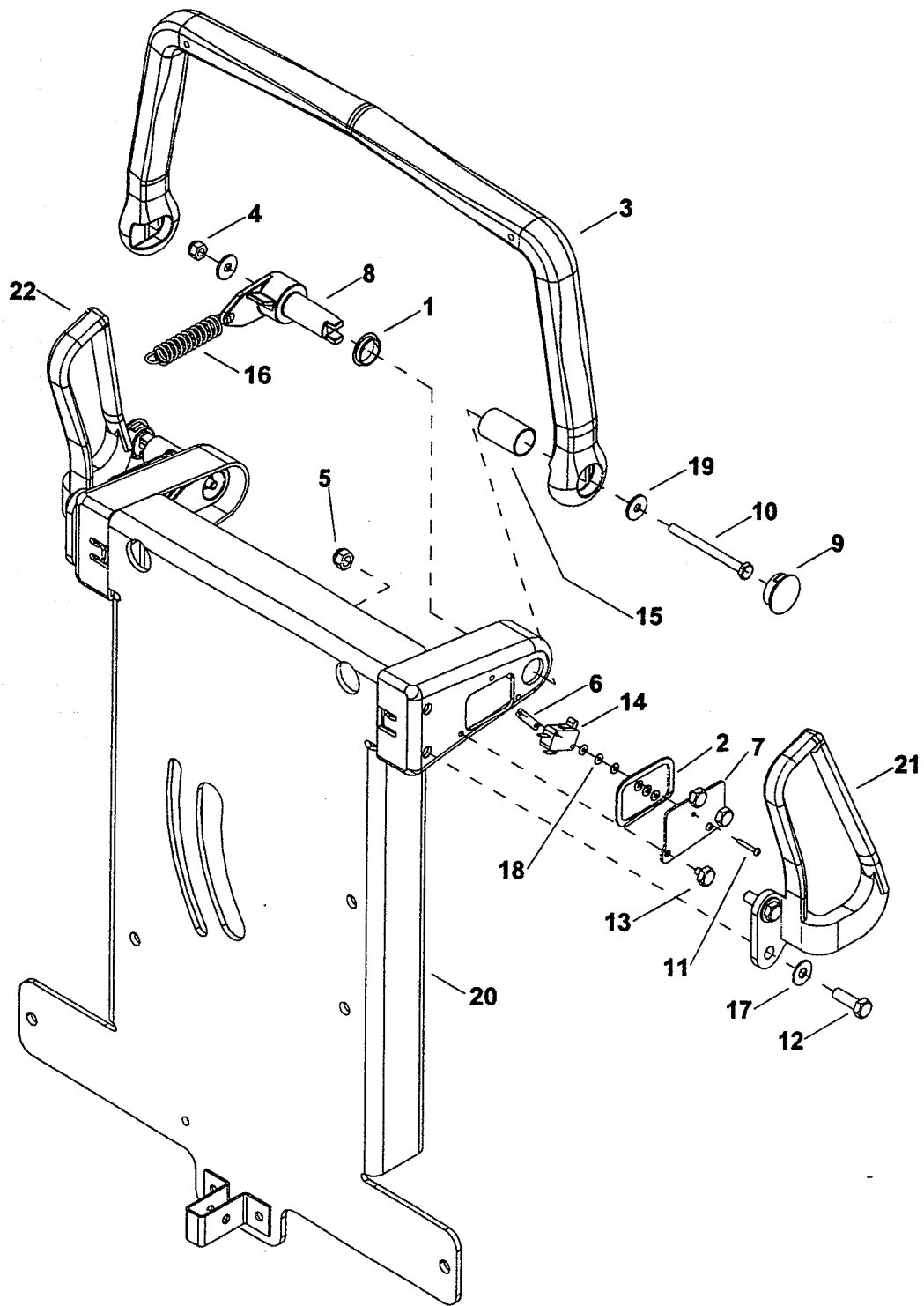

CONTROL HANDLE GROUP

REF	PART NO.	QTY	DESCRIPTION	SERIAL NO. FROM	NOTES:
1	09129	2	BEARING, 3/4 NYLINER SI		
2	35220	2	GASKET, MICRO SWITCH COVER		
3	38275	1	HANDLE, SABER		
4	57047	2	NUT, 1/4-20 HEX NYLOCK		
5	57113	4	NUT, 5/16-18 HEX NYLOCK		
6	57247	2	NUT, PLATE SWITCH MOUNTING		
7	62726	2	PLATE, MICROSWITCH MOUNT		
8	66293	2	PIVOT, HANDLE		
9	66301	2	PLUG, 1.00 HOLE		
10	70129	2	SCR, 1/4-20 X 3.00 HHCS		
11	70245	4	SCR, 4-40 X 3/4 PPHMS		
12	70302	4	SCR, 5/16-18 X 1.00 HHCS GR5		
13	70351	6	SCR, 10-32 X 3/8 HHTR W/STAR		
14	72093	2	SWITCH, MICRO		
15	73913	2	SPACER, 7/8 OD X .78 ID X 1.375 L		
16	73938	2	SPRING, EXT. .5D X 2.75L X .075W		
17	87029	4	WASHER, 5/16 X 3/4 SS		
18	87068	12	WASHER, 1/8 RIVET BACKUP		
19	87090	4	WASHER, 1/4 X 3/4 FLAT		
20	89186	1	WELDMENT, TOWER VALUE		
21	140247	1	BAR, GRAB HANDLE LEFT		
22	140248	1	BAR, GRAB HANDLE RIGHT		
23	98721	1	SERVICE TAG		NOT SHOWN
24	14382	1	BAND, SERVICE TAG		NOT SHOWN

CONTROL TOWER GROUP

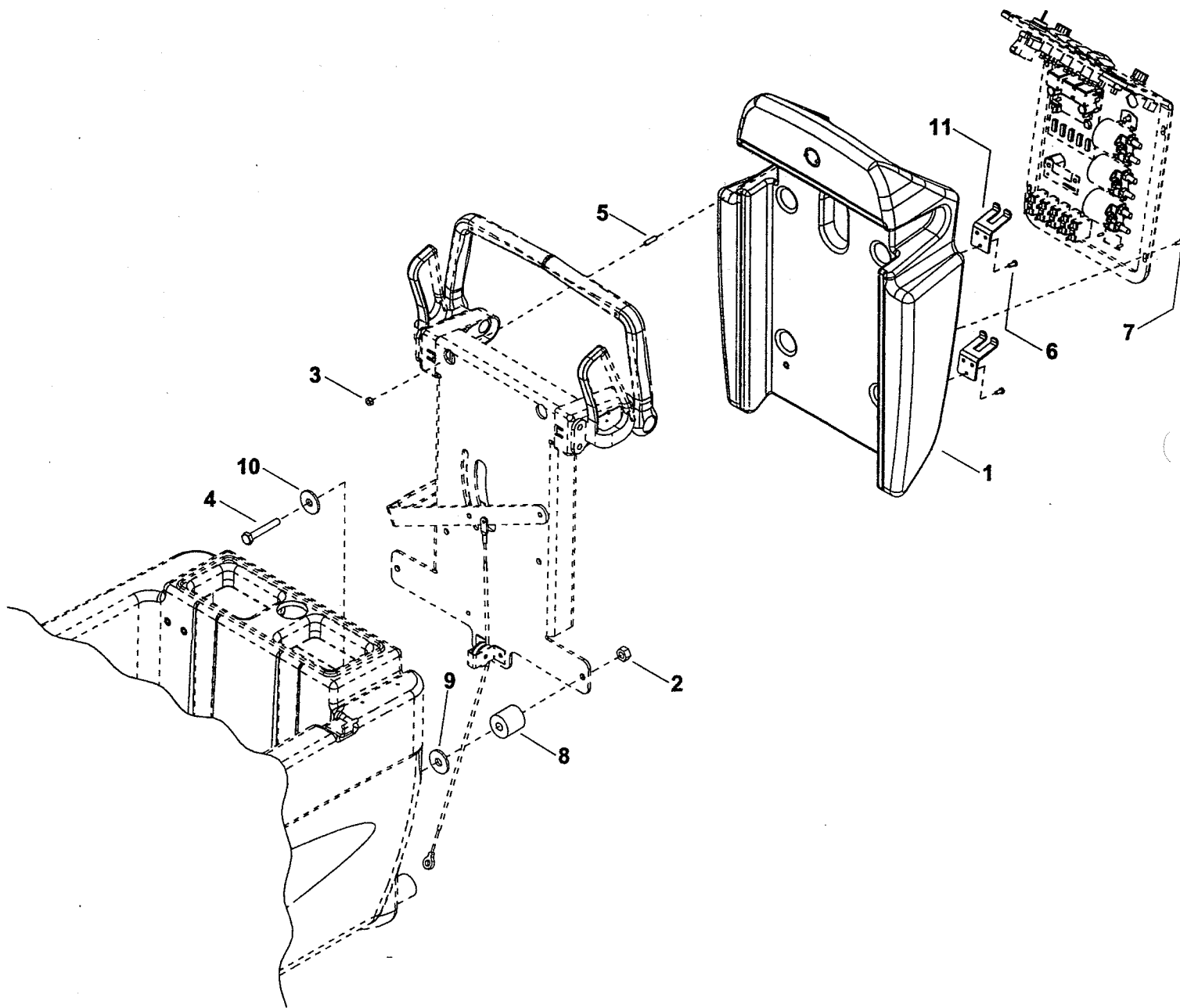

CONTROL TOWER GROUP

REF	PART NO.	QTY	DESCRIPTION	SERIAL NO. FROM	NOTES:
1	27874	1	CONSOLE, REAR		
2	57119	4	NUT, 3/8-16 HEX NYLOCK		
3	57189	4	NUT, 1/4-20 FLANGE LOCK		
4	70070	4	SCR, 3/8-16 X 2 HHCS SS		
5	70393	4	SET SCR, 1/4-20X 1.25L		
6	70403	6	SCR, #10 X 1/2 PHST TYPE B		
7	70532	6	SCR, 10-32 X 1/2 PPHMS BLK		
8	73974	4	SPACER, 1.13D X .41ID X .5THK		
9	87086	2	WASHER, M10 X 30 PLTD		
10	87185	4	WASHER, 3/8 SEALING X 3/4 OD		
11	140133	2	BRACKET, RECOVERY HOSE		

DECAL GROUP

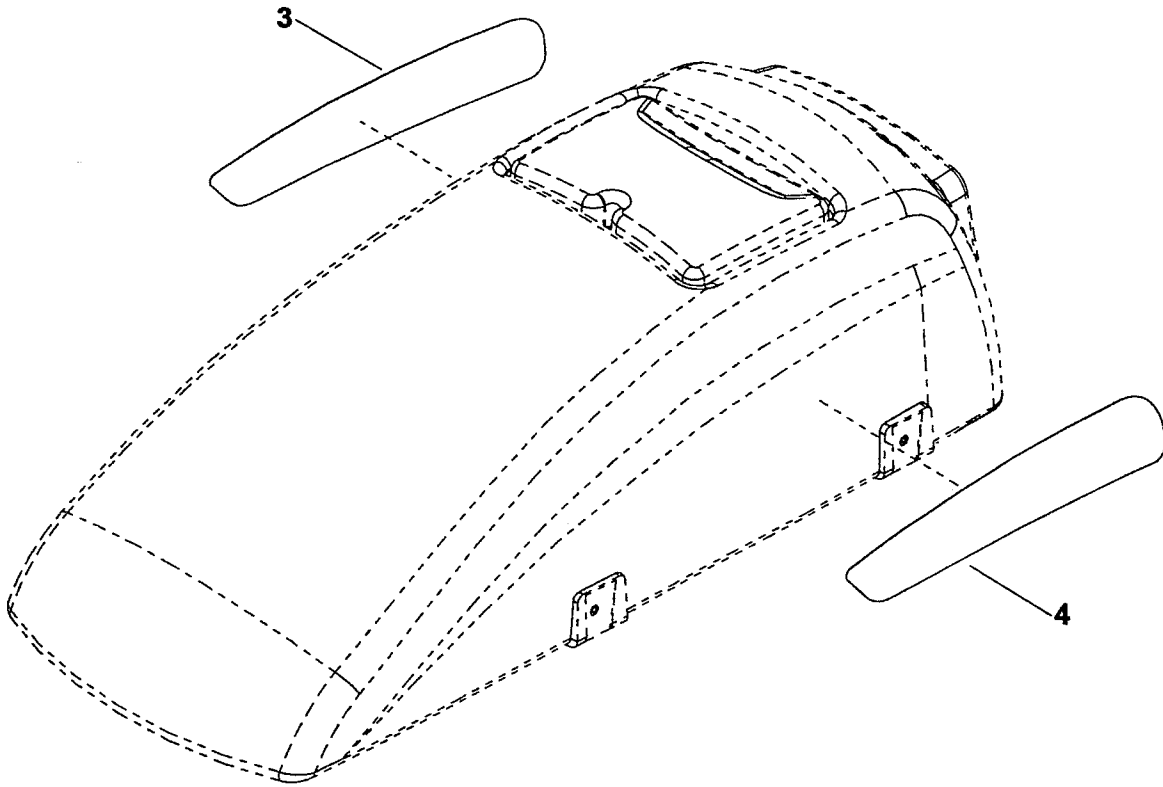
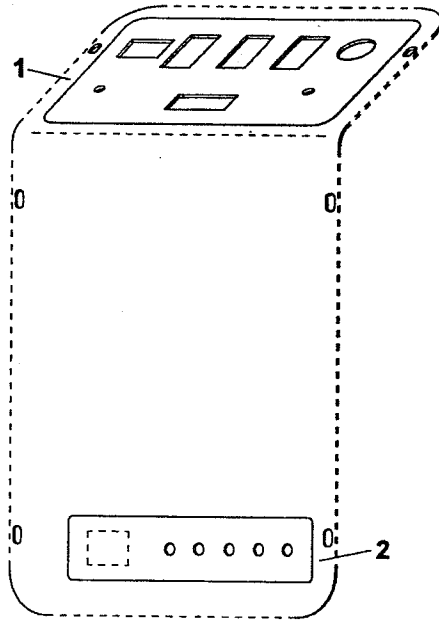

REF	PART NO.	QTY	DESCRIPTION	SERIAL NO. FROM	NOTES:
1	500023	1	LABEL, SCRUBBER PANEL		
2	500024	1	LABEL, CIRCUIT BREAKERS		
3	500161	1	LABEL, BETCO RIGHT		
4	500160	1	LABEL, BETCO LEFT		

NOTE: SEE "SAFETY LABEL LOCATION" PAGE FOR SAFETY LABEL INFORMATION.

ELECTRICAL PANEL GROUP

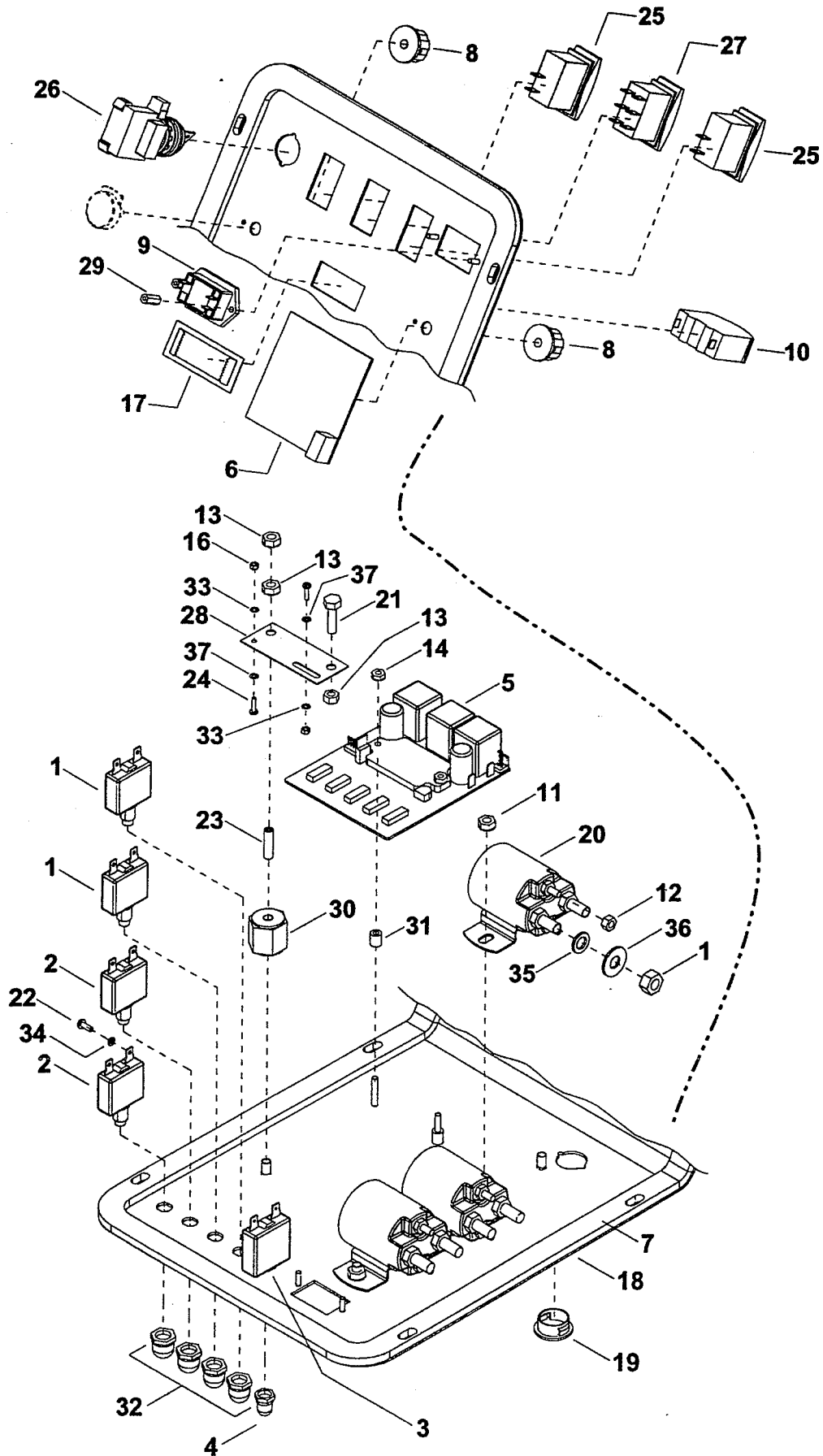

ELECTRICAL PANEL GROUP

REF	PART NO.	QTY	DESCRIPTION	SERIAL NO. FROM	NOTES:
1	14606	2	BREAKER, 30A 250VAC 50VDC		
2	14607	2	BREAKER, 25A 250VAC 50VDC		
3	14717	1	BREAKER, 3A 250VAC 50VDC		
4	14942	1	BOOT, 3/8 CIRCUIT BREAKER		
5	27695	1	CONTROLLER, 24VDC PROPEL MTR		
6	27858	1	CIRCUIT BOARD, SOLUTION/FLOAT		
7	35210	1	GASKET, ELECTRIC PANEL		
8	48072	2	KNOB, 1.06 OD X .25 ID W/SET SCR		
9	54145	1	METER, 24V BATTERY CHARGE LEVEL		
10	54156	1	METER, 0-50 AMP DC		
11	57047	4	NUT, 1/4-20 HEX NYLOCK		
12	57104	6	NUT, 10-32 W/STAR WASHER PLTD		
13	57105	3	NUT, 1/4-20 HEX W/STAR		
14	57106	2	NUT, 8-32 HEX W/STAR		
15	57117	6	NUT, 5/16-24 HEX PLTD		
16	57256	2	NUT, 6-32 HEX BRASS		
17	62283	1	PLATE, METER RETAINING		
18	62808	1	PLATE, ELECTRIC PANEL		
19	66321	1	PLUG, .875 HOLE		
20	67393	3	RELAY, 24VDC 100 AMP		
21	70011	1	SCR, 1/4-20 X 5/8 HHCS SS DL		
22	70067	8	SCR, 6-32 X 3/8 PPHMS SS		
23	70393	1	SET SCR, 1/4-20X 1.25L		
24	70615	2	SCR, 6-32 X 3/8 SRHMS BR		
25	72130	2	SWITCH, SPST 2-POSITION ROCKER		
26	72159	1	SWITCH, KEY 2 POSITION		
27	72165	1	SWITCH, DPDT 3-POSITION ROCKER		
28	73987	1	SHUNT, DC AMM. 25 AMP, 50 MV		
29	73538	2	STANDOFF, 5/8 L, 6-32		
30	73659	1	STANDOFF, INS. 1.0L, 1/4-20 THD		
31	73734	2	SPACER, .166 ID X .313 OD X .375L AL		
32	80845	4	BOOT, 3/8 CIRCUIT BREAKER		
33	87026	2	WASHER, #6 LOCK EXT STAR SS		
34	87134	8	WASHER, #6 SPLIT		
35	87142	6	WASHER, .344X.69X.066 FLAT PLT		
36	87166	6	WASHER, 5/16 EXT LOCK PLTD		
37	87187	2	WASHER, #6 FLAT BRASS		

FRONT COVER GROUP

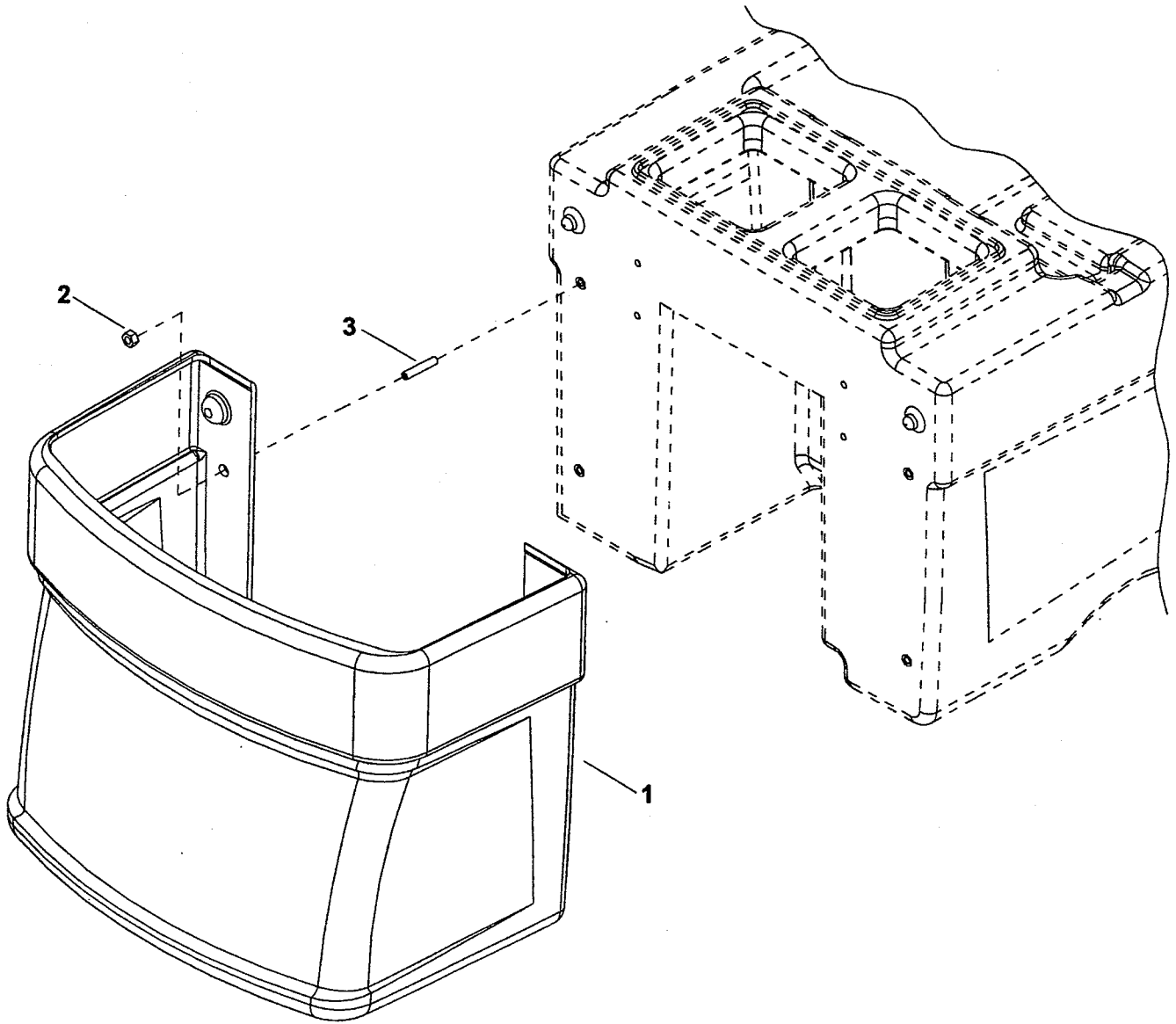

FRONT COVER GROUP

REF	PART NO.	QTY	DESCRIPTION	SERIAL NO. FROM	NOTES:
1	27875	1	COVER, FRONT		
2	57112	2	NUT, 5/16-18 SERRATED FLG		
3	70639	4	SCR, 5/16 X 1.75 SSSCU		

RECOVERY TANK GROUP

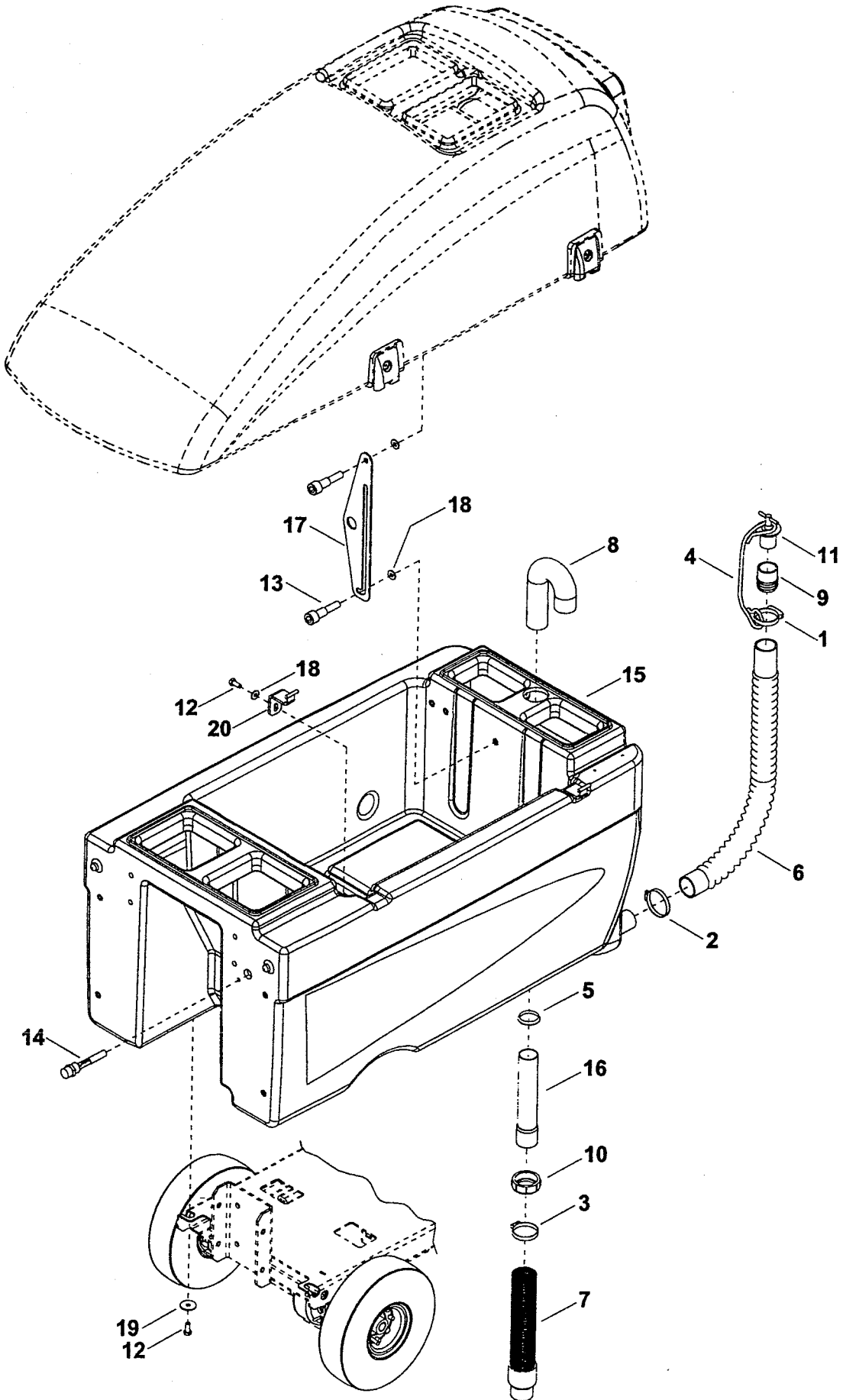

RECOVERY TANK GROUP

REF	PART NO.	QTY	DESCRIPTION	SERIAL NO. FROM	NOTES:
1	20002	1	CLAMP, 2" NYLON RACHET		
2	20046	1	CLAMP, 2.5" WORM GEAR		
3	20064	1	CLAMP, 2.0" WORM GEAR X .312W		
4	27670	1	CORD, DRAIN PLUG		
5	35219	1	GASKET, 1 1/2 COMPRESSION		
6	39472	1	HOSE, 1.5 X 24.0 DRAIN		
7	39511	1	HOSE ASM, 1.5 X 11 BLK VAC		
8	39519	1	HOSE, P-TRAP		
9	40019	1	HOSEBARB, 1.5 DOUBLE MCHD		
10	57033	1	NUT, 1.5 SLIP JOINT		
11	66227	1	PLUG, DRAIN HOSE		
12	70305	6	SCR, 5/16-18 X 3/4HHCSGR5PLTDL		
13	70641	2	SHOULDER BOLT, 3/8OD X 3/8L SS		
14	73906	1	SWITCH ASM, FLOAT		
15	75309	1	TANK, RECOVERY		
16	78406	1	TUBE, 1.50 X 8.00 PVC		
17	82575	1	PLATE, TANK SUPPORT		
18	87029	4	WASHER, 5/16 FLAT SS		
19	87102	4	WASHER, 5/16 ID X 1-1/4 OD		
20	89127	2	WLDMNT, HINGE PIN		

SCRUB BRUSH/PAD DRIVER GROUP – 32 IN

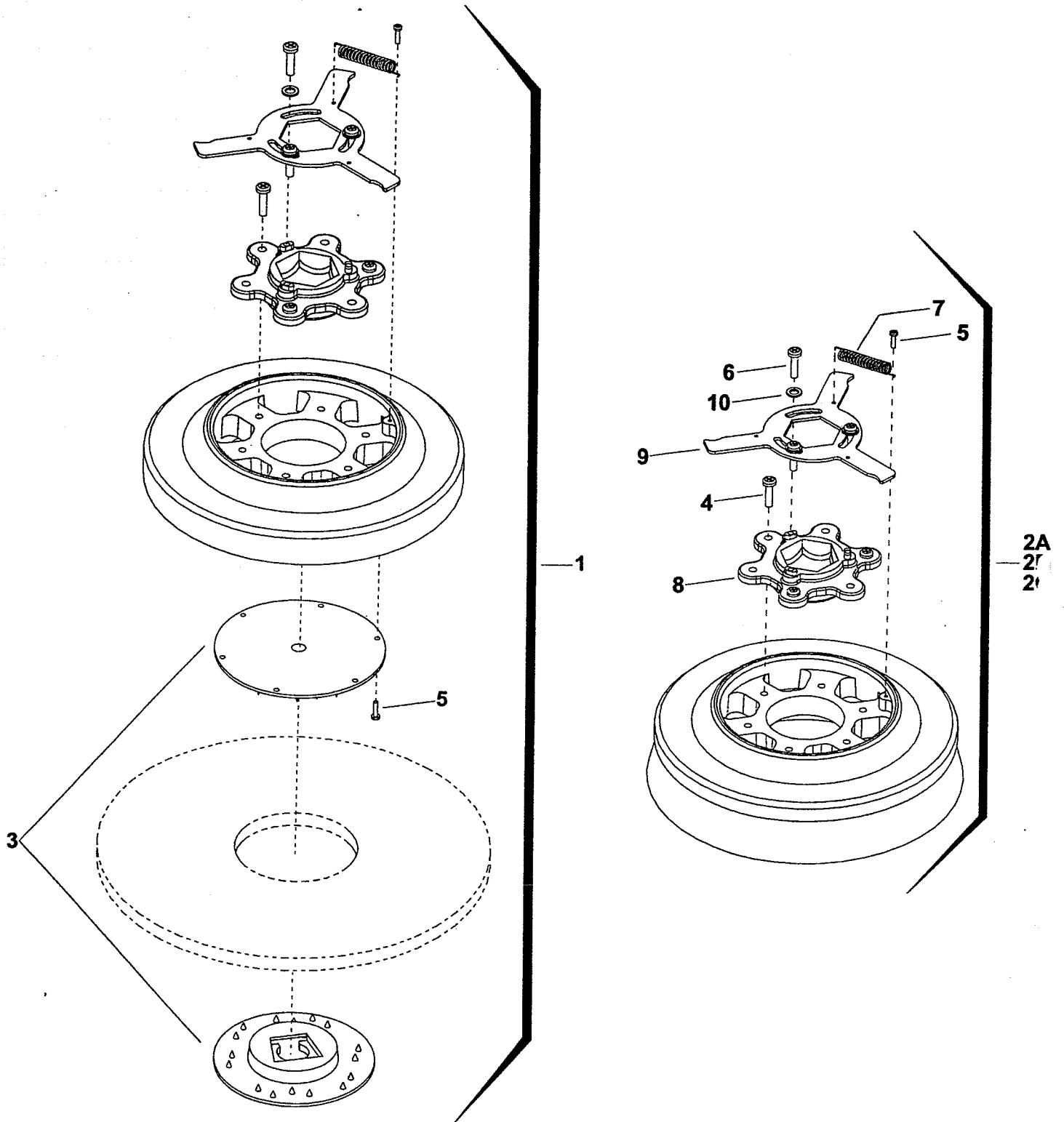

SCRUB BRUSH/PAD DRIVER GROUP - 32 IN

REF	PART NO.	QTY	DESCRIPTION	SERIAL NO. FROM	NOTES:
1	02364	-	PAD DRIVER, 16" HEX		
2A	02365	-	BRUSH, 16" POLYPROPYLENE HEX		
2B	02366	-	BRUSH, 16" NYLON HEX		
2C	02368	-	BRUSH, 16" MILD GRIT HEX		
3	51284	-	LOCK, PAD CENTER SNAP, TWO STEP		
4	70682	-	SCR, 1/4-20 X 5/8 PPHTC SS		
5	70576	-	SCR, #8 X 1/2 PPH T/S SS		
6	70682	-	SCR, 1/4-20 X 5/8 PPHTC SS		
7	73817	-	SPRING, EXT .31D X 2.0L X .03W		
8	73861	-	CLUTCH, HEX DRIVE		
9	81471	-	PLATE, BRUSH RELEASE		
10	87013	-	WASHER, 1/4 ID X 5/8 OD SS		

SCRUB BRUSH/PAD DRIVER GROUP – 28 IN

REF	PART NO.	QTY	DESCRIPTION	SERIAL NO. FROM	NOTES:
1	02337	-	PAD DRIVER, 14" HEX		
2A	02344	-	BRUSH, 14" POLYPROPYLENE HEX		
2B	02345	-	BRUSH, 14" NYLON HEX		
2C	02346	-	BRUSH, 14" MILD GRIT HEX		
3	51284	-	LOCK, PAD CENTER SNAP, TWO STEP		
4	70682	-	SCR, 1/4-20 X 5/8 PPHTC SS		
5	70576	-	SCR, #8 X 1/2 PPH T/S SS		
6	70682	-	SCR, 1/4-20 X 5/8 PPHTC SS		
7	73817	-	SPRING, EXT .31D X 2.0L X .03W		
8	73861	-	CLUTCH, HEX DRIVE		
9	81471	-	PLATE, BRUSH RELEASE		
10	87013	-	WASHER, 1/4 ID X 5/8 OD SS		

SCRUBHEAD GROUP - 28 IN

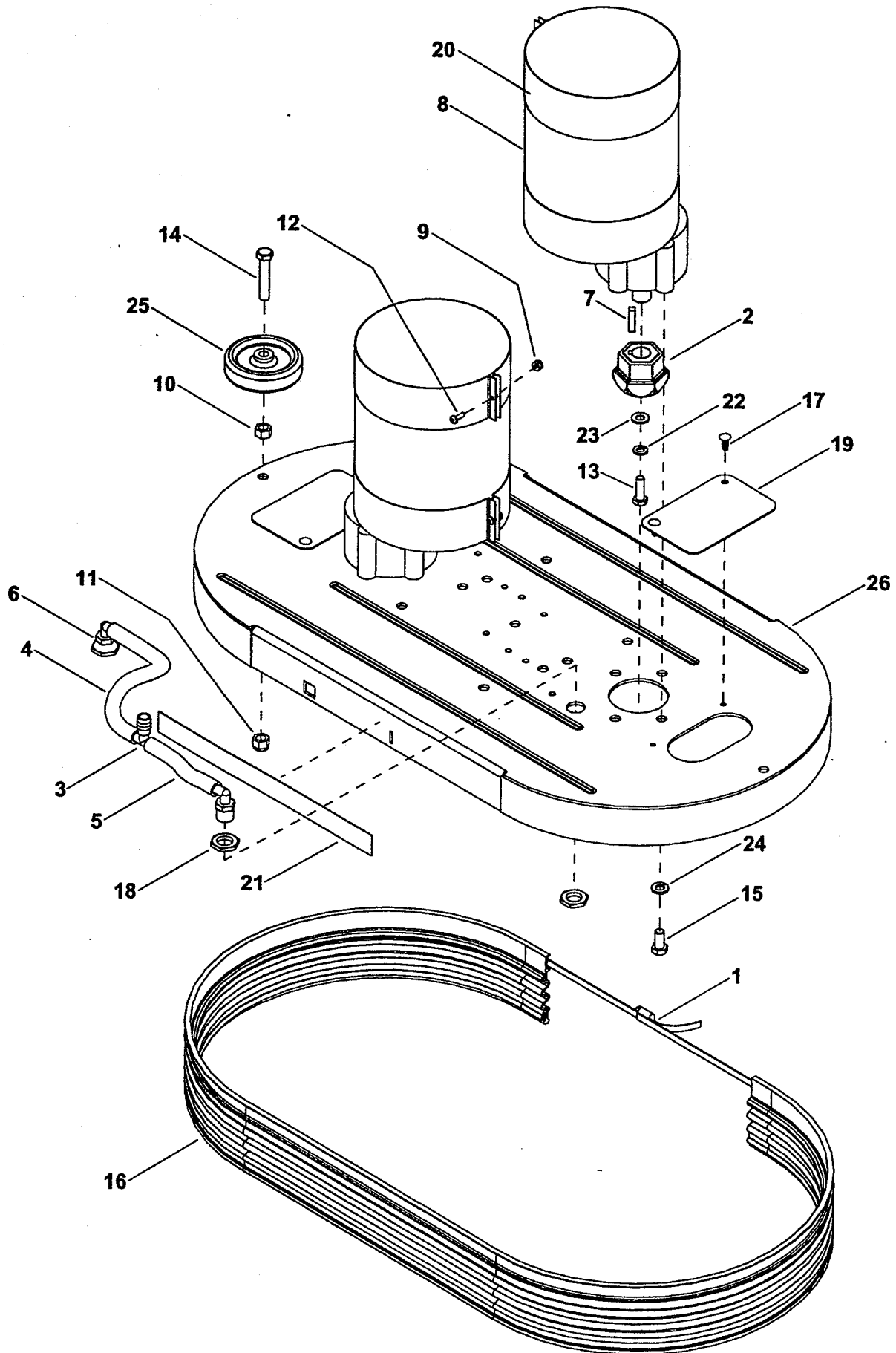

SCRUBHEAD GROUP - 28 IN

REF	PART NO.	QTY	DESCRIPTION	SERIAL NO. FROM	NOTES:
1	20076	1	CLAMP, WORM GEAR .5W X 24 #390		
2	29119	2	DRIVER, BRUSH		
3	34327	1	FITTING, 1/2 X 3/8 X 3/8 RED. TEE		
4	39053	1	HOSE, 3/8 NYLOBRAID X 7.0"		
5	39452	1	HOSE, 3/8 NYLOBRAID X 5-1/2"		
6	40043	2	HOSEBARB, 3/8 MPT X 3/8 HOSE 90		
7	48040	2	KEY, 1/4 SQ X 1.00		
8	53632	2	MOTOR, 36VDC 200 RPM 3/4 HPGEAR		
	14647	-	BRUSH SET, IMPERIAL MOTOR		(NOT SHOWN)
9	57026	4	NUT, 8-32 HEX NYLOCK		
10	57111	1	NUT, 3/8-16 HEX		
11	57119	1	NUT, 3/8-16 HEX NYLOCK		
12	70051	4	SCR, 8-32 X 1/2 PPHMS SS		
13	70083	2	SCR, 5/16-18 X 1.00 HHCS SS		
14	70385	1	SCR, 3/8-16 X 2.00 HHCS GR5		
15	70507	8	SCR, 3/8-16 X 3/4 HHCS GR5		
16	73889	1	SKIRT, SHROUD 3.25 X 65.0 L		
17	80805	4	CLIP, TREE .19 HOLE FLAT HEAD		
18	81380	4	NUT, SEALED BULKHEAD		
19	81898	2	COVER, BRUSH RELEASE		
20	82259	4	GUARD, MOTOR		
21	82923	1	PAD, ANTI SLIP 1.00 X 12.0 L		
22	87083	2	WASHER, 5/16 SPLIT		
23	87142	2	WASHER, .34 X .69 FLAT		
24	87163	8	WASHER, 3/8 SPLIT		
25	89059	1	WHEEL, PT20 SQUEEGEE		
26	89193	1	WELDMENT, SCRUB HEAD 28IN		

SCRUBHEAD GROUP – 32 IN

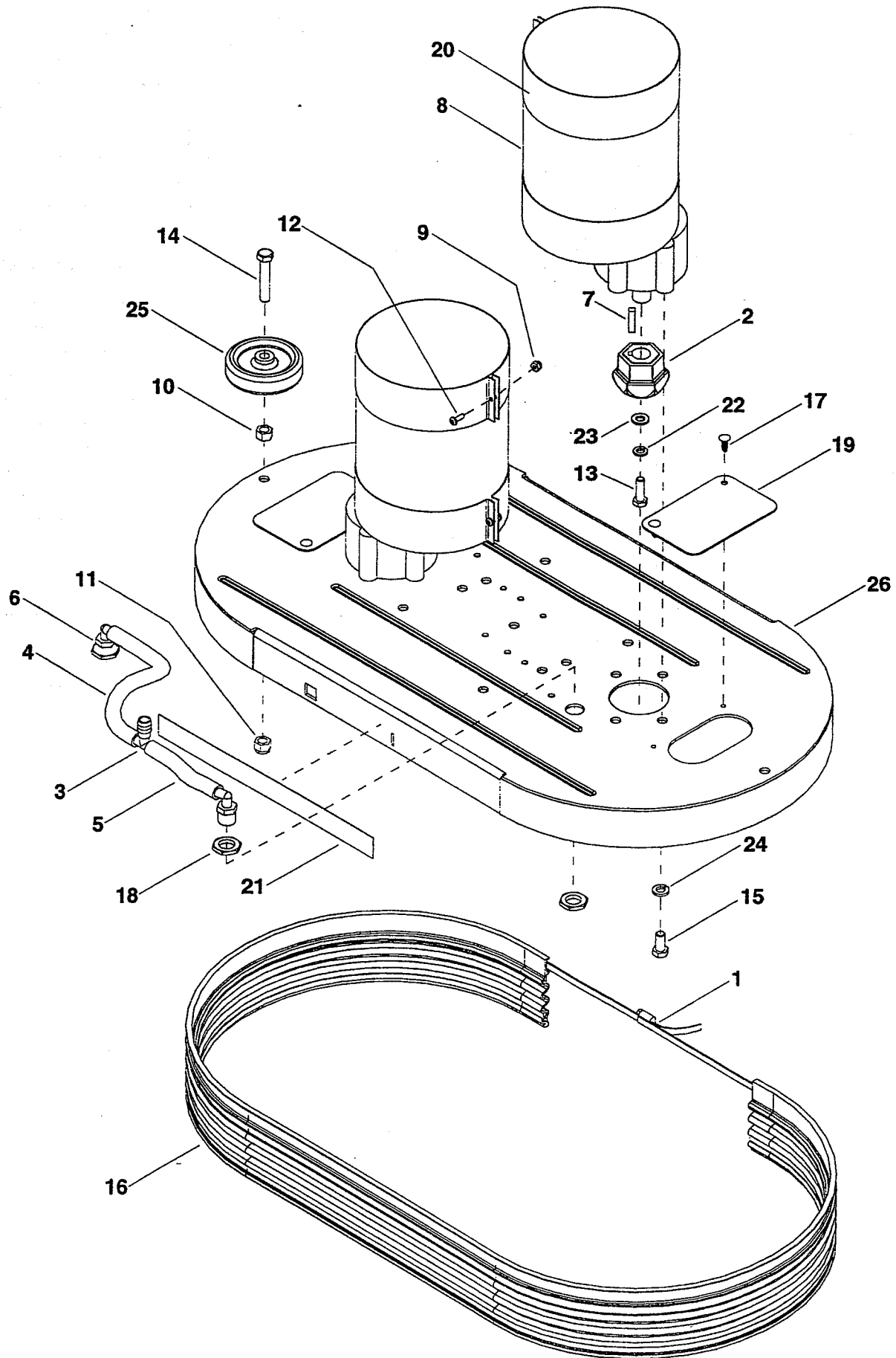

SCRUBHEAD GROUP -32 IN

REF	PART NO.	QTY	DESCRIPTION	SERIAL NO. FROM	NOTES:
1	20076	1	CLAMP, WORM GEAR .5WX24 #390		
2	29119	2	DRIVER, BRUSH		
3	34327	1	FITTING, 1/2 X 3/8 X 3/8 RED. TEE		
4	39053	1	HOSE, 3/8 NYLOBRAID X 7.0"		
5	39486	1	HOSE, 3/8 NYLOBRAID X 5-1/2"		
6	40043	2	HOSEBARB, 3/8 MPT X 3/8 HOSE 90		
7	48040	2	KEY, 1/4 SQ X 1.00		
8	53630	2	MOTOR ASM, 24VDC 200 RPM GEAR		
	14695	-	BRUSH SET, BRUSH MOTOR		(NOT SHOWN)
9	57026	4	NUT, 8-32 HEX NYLOCK		
10	57111	1	NUT, 3/8-16 HEX		
11	57119	1	NUT, 3/8-16 HEX NYLOCK		
12	70051	4	SCR, 8-32 X 1/2 PPHMS SS		
13	70083	2	SCR, 5/16-18 X 1.00 HHCS SS		
14	70385	1	SCR, 3/8-16 X 2.00 HHCS GR5		
15	70507	8	SCR, 3/8-16 X 3/4 HHCS GR5		
16	73889	1	SKIRT, SHROUD 3.25 X 65.0 L		
17	80805	4	CLIP, TREE .19 HOLE FLAT HEAD		
18	81380	4	NUT, SEALED BULKHEAD		
19	81898	2	COVER, BRUSH RELEASE		
20	82259	4	GUARD, MOTOR		
21	82923	1	PAD, ANTI SLIP 1.00 X 12.0 L		
22	87083	2	WASHER, 5/16 SPLIT		
23	87142	2	WASHER, .34 X .69 FLAT		
24	87163	8	WASHER, 3/8 SPLIT		
25	89059	1	WHEEL, PT20 SQUEEGEE		
26	89218	1	WELDMENT, SCRUB HEAD 32IN		

SCRUBHEAD LIFT GROUP

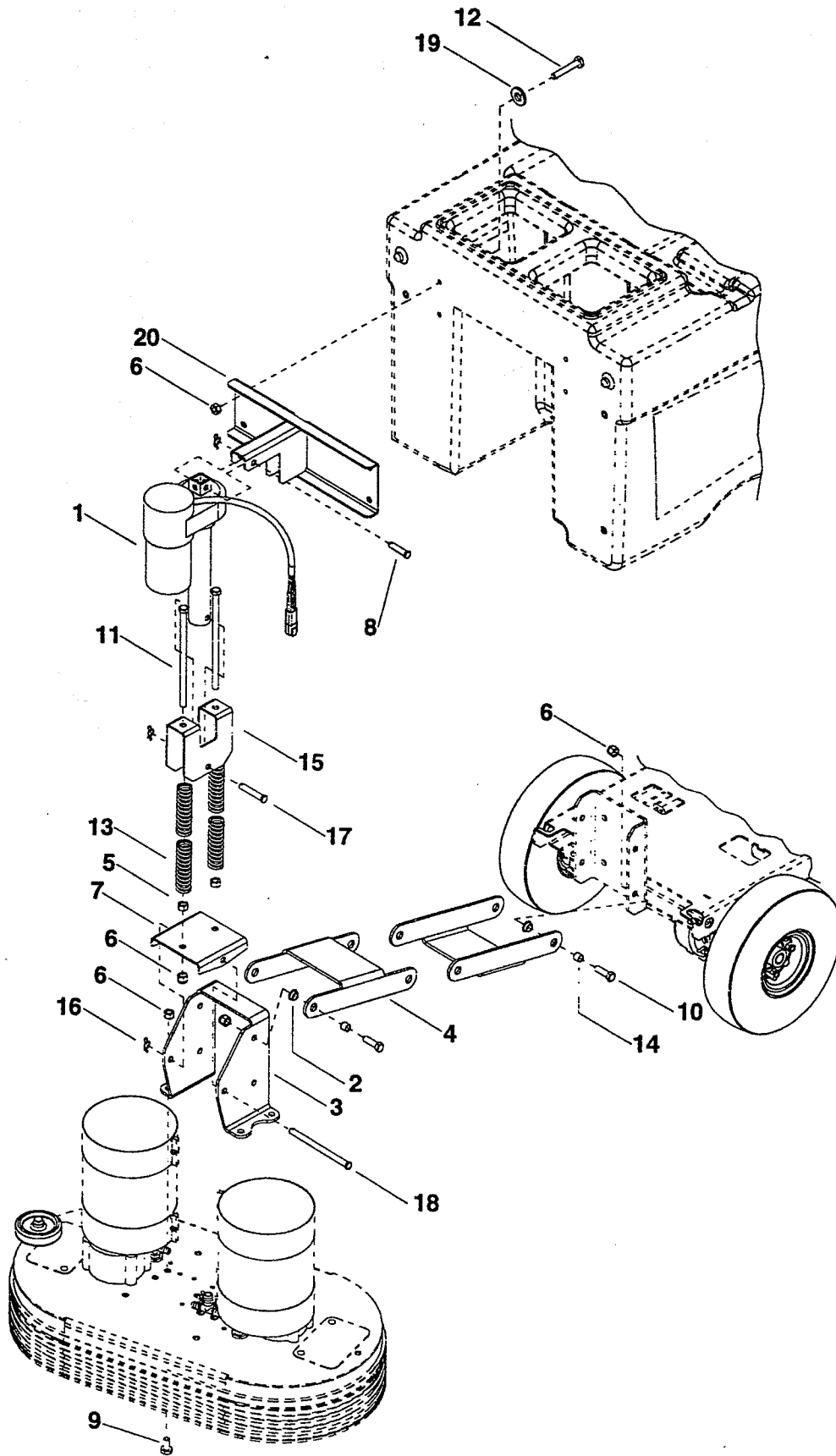

SCRUBHEAD LIFT GROUP

REF	PART NO.	QTY	DESCRIPTION	SERIAL NO. FROM	NOTES:
1	05123	1	ACTUATOR, 24 VDC 5.0 STROKE		
2	09130	8	BEARING, 1/2 NYLINER SF		
3	140372	1	BRKT, SCRUB HEAD MOUNT		
4	27856	2	LINKAGE, SCRUB DECK SV		
5	57111	2	NUT, 3/8-16 HEX		
6	57119	18	NUT, 3/8-16 HEX NYLOCK		
7	62676	1	PLATE, SPRING SUPPORT		
8	66232	1	PIN, CLEVIS 3/8 X 1.50		
9	70266	4	SCR, 3/8-16 X 1" HHCSGR5PLT DL		
10	70377	8	SCR, 3/8-16 X 1.25 HHCS GR5		
11	70574	2	SCR, 3/8-16 X 7.5 HHCS GR5 PLTD		
12	70662	4	SCR, 3/8-16 X 1.25 HHMS SS		
13	73883	4	SPRING, COMP. .97 OD X 3.5 L		
14	80102	8	SPACER, .500 OD X .391 ID X .400		
15	80459	1	PLATE, SPRING RETAINER		
16	80606	3	COTTER, 3/8" RING		
17	81406	1	PIN, CLEVIS 3/8" X 2"		
18	82060	1	PIN, CLEVIS 3/8 X 5.25		
19	87185	4	WASHER, 3/8 SEALING X 3/4 OD		
20	89184	1	WELDMENT, ACTUATOR MOUNT		

SOLUTION TANK GROUP

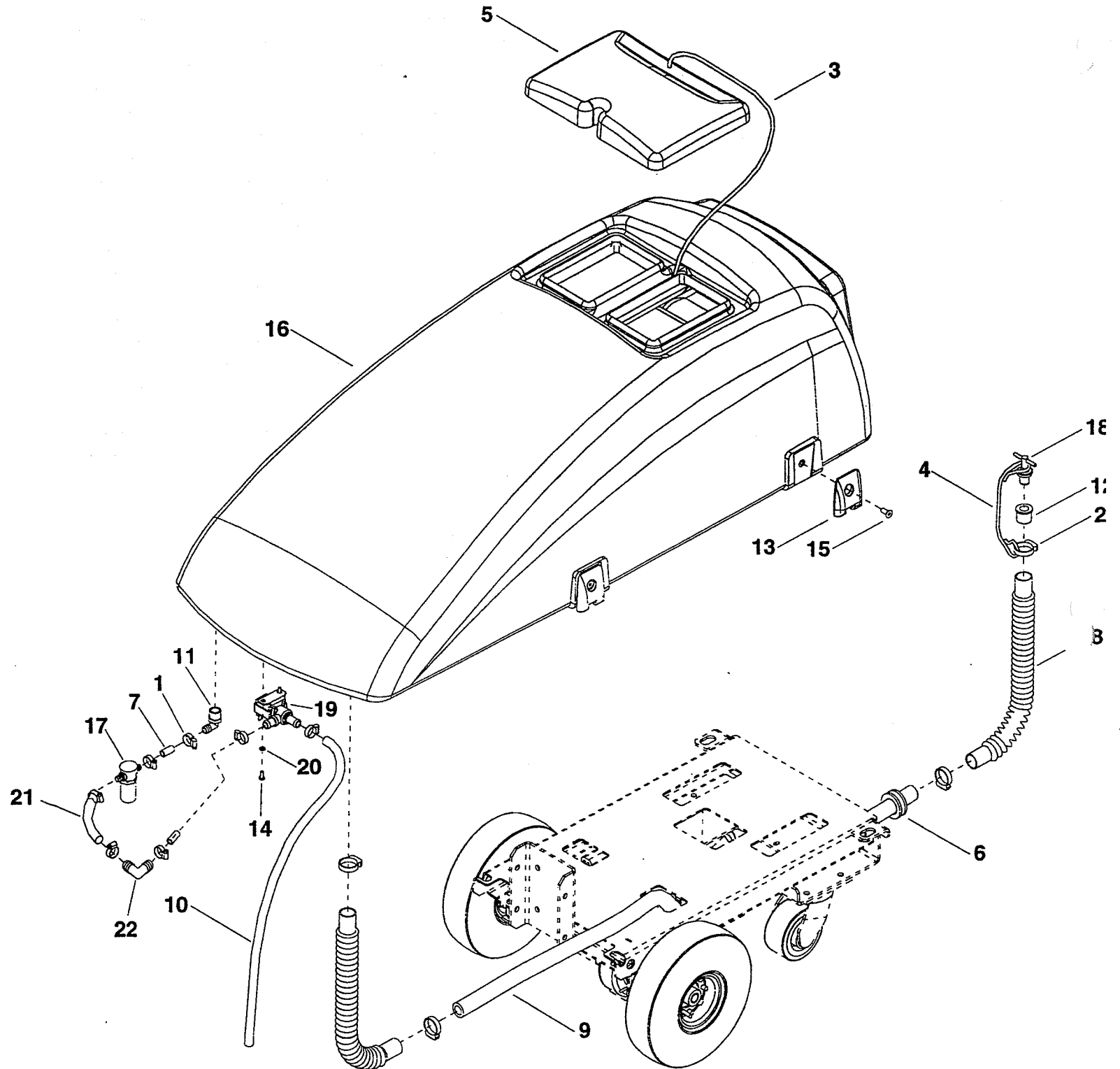

SOLUTION TANK GROUP

REF	PART NO.	QTY	DESCRIPTION	SERIAL NO. FROM	NOTES:
1	20042	6	CLAMP, 3/8 HOSE (D-SLOT)		
2	20090	4	CLAMP, 1.0 NYLON RACHET		
3	27425	1	CORD, SOLUTION COVER		
4	27670	1	CORD, DRAIN PLUG		
5	27772	1	COVER, SOLUTION TANK		
6	36191	1	GROMMET 1.00 ID 3/16 GRIP		
7	39498	2	HOSE, 1/2" NYLOBRAID X 1 1/2"		
8	39505	2	HOSE, 1.0 X 18.0 DRAIN		
9	39514	1	HOSE, 3/4 ID X .12W X 32" CLR		
10	39521	1	HOSE, 1/2 NYLOBRAID X 36"		
11	40039	1	HOSEBARB, 1/2MPT X 1/2 HOSE 90		
12	40076	1	SLEEVE .63 ID X 1.0 OD		
13	41333	2	HINGE, SCRUBBER TANK		
14	70088	2	SCR, 10-32 X 1/2 PPHMS SS		
15	70632	2	SCR, 5/16-18 X 3/4 FHSCS BLKZC		
16	75310	1	TANK, SOLUTION		
17	73999	1	STRAINER, 1/2 HOSE 40 MESH		
18	82267	1	PLUG, 5/8" DRAIN HOSE		
19	84141	1	VALVE, 24VDC SOL.1/2"HOSEBARB		
20	87095	2	WASHER, #10 FLAT PLTD		
21	39549	1	HOSE, 1/2" WIRE BOUND X 5"		
22	40082	1	HOSEBARB, 1/2 X 90D		

SQUEEGEE GROUP - 28 IN SCRUBHEAD

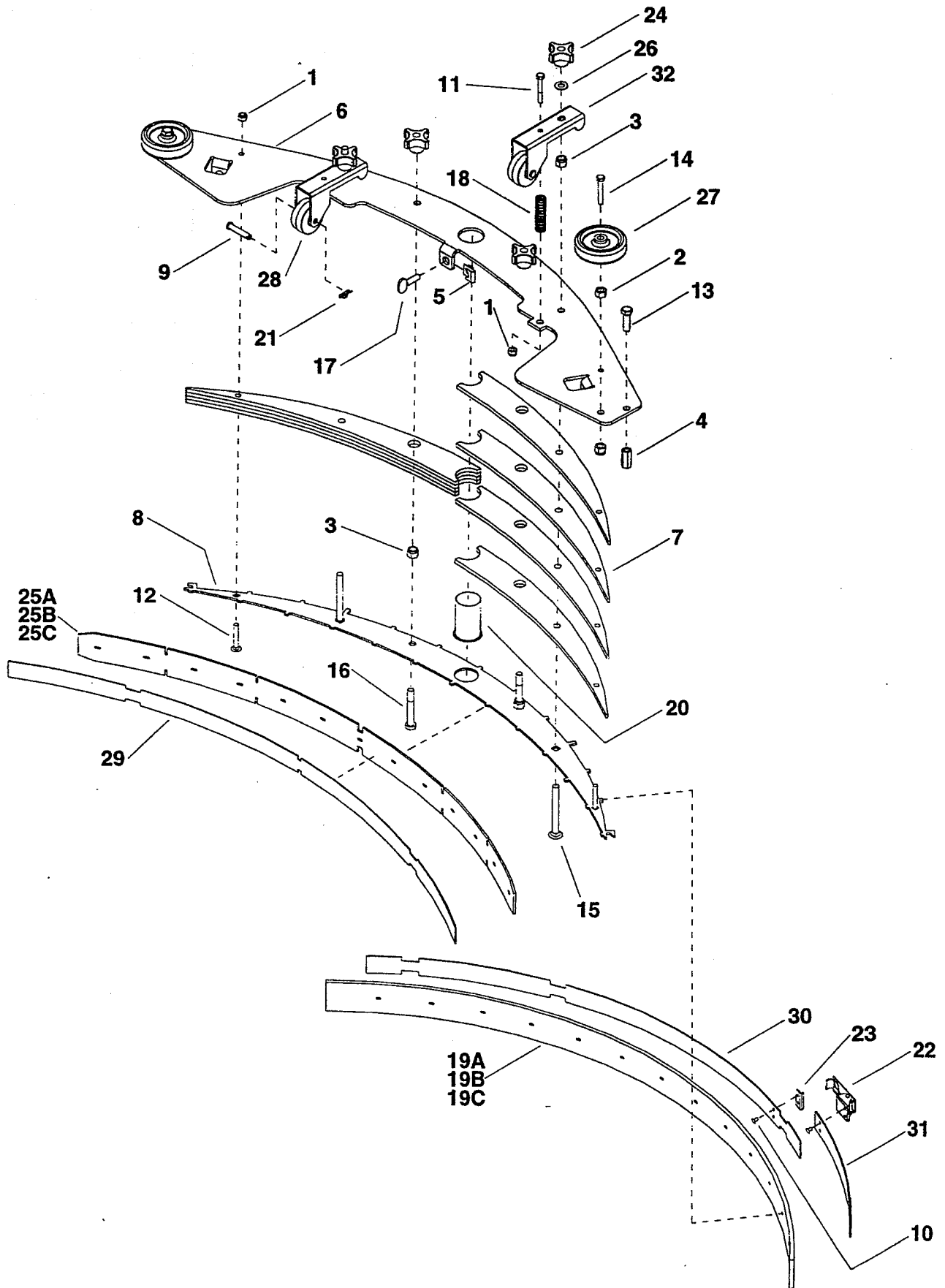

SQUEEGEE GROUP - 28 IN SCRUBHEAD

REF	PART NO.	QTY	DESCRIPTION	SERIAL NO. FROM	NOTES:
1	57047	4	NUT, 1/4-20 HEX NYLOCK		
2	57111	2	NUT, 3/8-16 HEX		
3	57119	6	NUT, 3/8-16 HEX NYLOCK		
4	57269	2	NUT, 3/8-16 HEX COUPLING SS		
5	57270	3	NUT, 5/16-18 CAPTIVE "J" PLTD		
6	62811	1	PLATE, SQG RETAINER TOP		
7	62812	8	PLATE, SQUEEGEE FILLER		
8	62813	7	PLATE, SQG BLADE RETAINER		
9	66276	2	PIN, CLEVIS 5/16 X 1.625 LG		
10	67380	4	RIVET, 5/32 OF X 1/8 GRIP		
11	70105	2	SCR, 1/4-20 X 1.75 HHCS PLTD		
12	70291	2	SCR, 1/4-20 X 1.5 ELEVATOR		
13	70377	2	SCR, 3/8-16 X 1.25 HHCS GR5PLT		
14	70385	2	SCR, 3/8-16 X 2.0 HHCS GR5 PLT		
15	70678	2	SCR, 3/8-16X3.5 CARRIAGE PLTD		
16	70679	2	SCR, 3/8-16 X 2.5 TAP		
17	70680	3	SCR, 5/16-18X1 THUMB SS TYPE P		
18	73576	2	SPRING, COMP .60D X2.0L X.045W		
19A	73900	1	SQGE BLADE, REAR LINATEX 44"		(STANDARD)
19B	73902	-	SQGE BLADE, REAR (TILE) 44"		(OPTION)
19C	73901	-	SQGE BLADE, REAR (BUTTONS) 44"		(OPTION)
20	78034	1	TUBE, 1.5 OD X 2.5 VAC INTAKE		
21	80605	2	COTTER, 5/16" RING		
22	81488	1	LATCH, SQUEEGEE STRAP		
23	81489	1	STRIKER, SQUEEGEE STRAP REAR		
24	81535	4	KNOB, 3/8-16 4 PRONG		
25A	82528	1	SQUEEGEE, FRONT BLADE LINATEX		(STANDARD)
25B	82637	-	SQUEEGEE, FRONT BLADE (TILE)		(OPTION)
25C	82640	-	SQUEEGEE, FRONT BLADE (BUTTON)		(OPTION)
26	87030	2	WASHER, 3/8 ID X 3/4 OD NYLON		
27	89059	2	WHEEL, BUMPER		
28	89197	2	WHEEL, 2 OD X.31IDX.875W, GRY		
29	140380	1	BAND, SQUEEGEE FRONT		
30	140381	1	BAND, SQUEEGEE REAR		
31	140382	1	BAND, SQUEEGEE REAR (S)		
32	140385	2	BRKT, WHEEL MOUNT		

SQUEEGEE LIFT GROUP

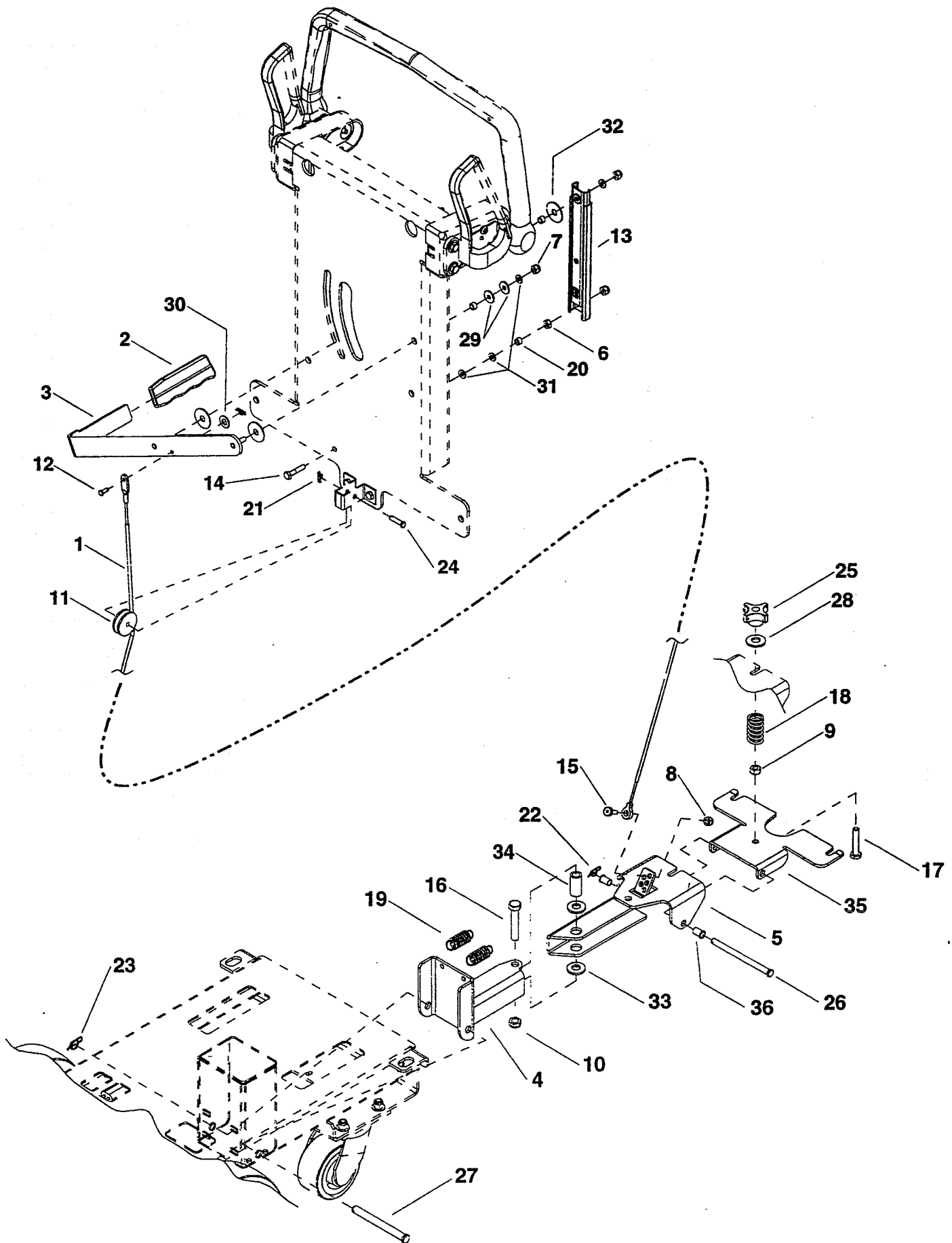

SQUEEGEE LIFT GROUP

REF	PART NO.	QTY	DESCRIPTION	SERIAL NO. FROM	NOTES:
1	27794	1	CABLE, 23.70 X 1/8		
2	36133	1	GRIP, 3/16 X 1.0 FLAT BAR		
3	51289	1	LEVER, SQUEEGEE LIFT		
4	51322	1	LINKAGE, SQUEEGEE LIFT		
5	51323	1	LINKAGE, SQUEEGEE PIVOT		
6	57006	1	NUT, 1/4-20 HEX		
7	57047	3	NUT, 1/4-20 HEX NYLOCK		
8	57113	1	NUT, 5/16-18 HEX NYLOCK		
9	57119	1	NUT, 3/8-16 HEX NYLOCK		
10	57153	1	NUT, 1/2-13 X HEX NYLOCK THIN		
11	64096	1	PULLEY, 1.5 OD X .5 W X .25 B		
12	66191	1	PIN, CLEVIS 3/16" X 1/2" PLTD		
13	67423	1	RAIL RACHET		
14	70297	1	SCR, 1/4-20 X 1.5 HHMS		
15	70641	1	SHOULDER BOLT, 3/8OD X 3/8L SS		
16	70341	1	SCR, 1/2-13 X 2.5 HHCS GR5PLT		
17	70685	1	SCR, 3/8-16 X2.75 HHTB GR5 PLTD		
18	730006	1	SPRING, COMP 1.100DX2.0LX.148W		
19	73979	2	SPRING, EXT. 1.00 OD X 4.0 L		
20	78430	3	TUBE, .38 OD X .26 ID X .38 LG		
21	80604	2	COTTER, 1/4 RING		
22	80606	1	COTTER, 3/8 RING		
23	80607	1	COTTER, 1/2 RING		
24	80612	1	PIN, CLEVIS 1/4 X 1.0		
25	48077	1	KNOB, 3.50 ODX3/8-16 THRU HOLE		
26	82060	1	PIN, CLEVIS 3/8 X 5.25		
27	82322	1	PIN, CLEVIS 1/2 X 4.80		
28	87086	1	WASHER, M10 X 30 PLTD		
29	87030	2	WASHER, 3/8 ID X 3/4 OD NYLON		
30	87056	1	WASHER, M6 FLAT		
31	87135	4	WASHER, .26 ID X .50 OD		
32	87200	3	WASHER, .4 ID X 1.3 OD NYLON		
33	87201	2	WASHER, 0.781 ID FIBERGLIDE		
34	140293	1	SPACER, .75 OD X .50 ID X 1.50 L		
35	140379	1	BRACKET, SQUEEGEE MOUNT		
36	80815	2	BEARING, FLANGED PLASTIC		

VACUUM GROUP

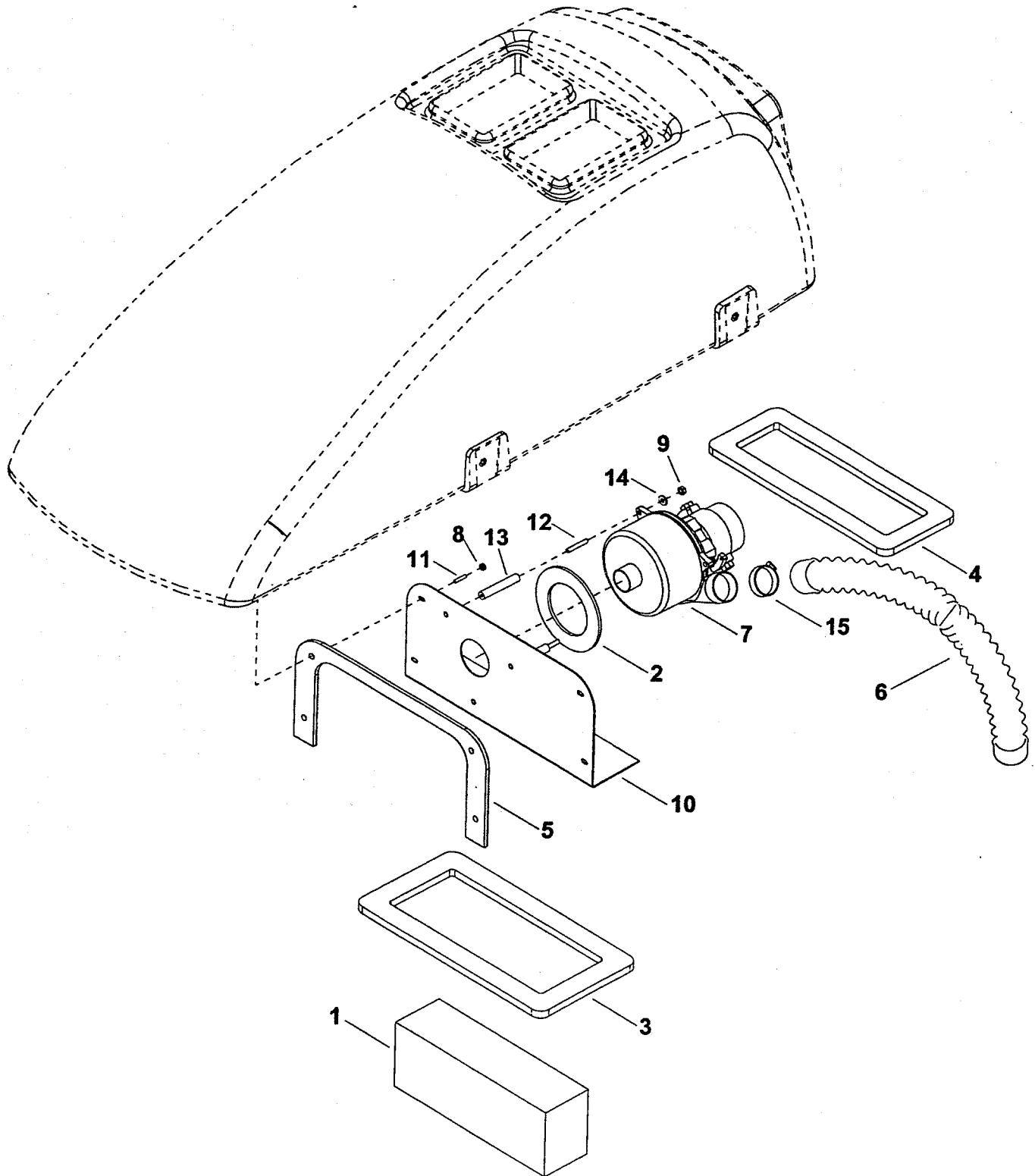

VACUUM GROUP

REF	PART NO.	QTY	DESCRIPTION	SERIAL NO. FROM	NOTES:
1	34337	1	FILTER, VAC		
2	35122	1	GASKET, 230V C17EI/C20 VAC MOTOR		
3	35211	1	GASKET, 8.50 X 16.40 X .50T		
4	35212	1	GASKET, 6.30 X 16.1 C .50T		
5	35214	1	GASKET, VAC MOTOR		
6	39239	1	HOSE, VAC EXHAUST X 24"		
7	53631	1	VAC MOTOR ASM, 24VDC 3 STAGE		
	14548	-	BRUSH SET, 24VDC 5.7 3ST VCMTR		(NOT SHOWN)
8	57104	4	NUT, 10-32 W/STAR WASHER PLTD		
9	57245	3	NUT, 1/4-20 HEX NYLOCK SS		
10	62805	1	PLATE, VAC MOUNT		
11	70607	4	SET SCR, #10-32 X 1.00 SS		
12	70638	3	SCR, 1/4-20 X 1.75 SSSCU		
13	73566	3	SPACER, 1/2 OD X 3.0 W/1/4-20 AL		
14	87013	3	WASHER, 1/4 ID X 5/8 OD SS		
15	20046	1	CLAMP, 2.25" WORM CLAMP		

WHEELS AND FRAME GROUP

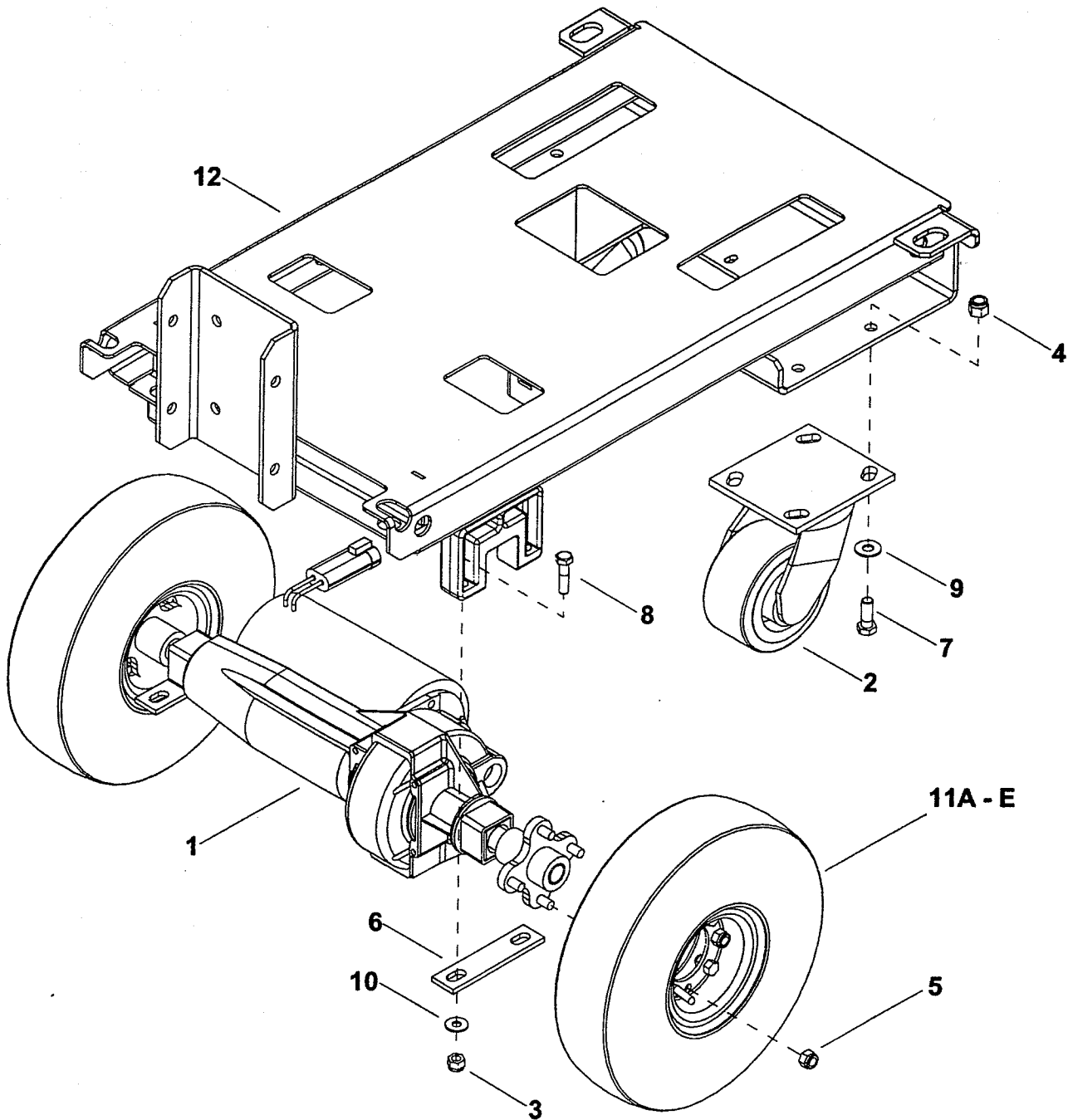

WHEELS AND FRAME GROUP

REF	PART NO.	QTY	DESCRIPTION	SERIAL NO. FROM	NOTES:
1	05128	1	AXLE, MOTOR DRIVE 24 VDC		
2	18041	2	CASTER, 4" DIA. X 2 X 3.56 R		
3	57113	4	NUT, 5/16-18 HEX NYLCK		
4	57119	8	NUT, 3/8-16 HEX NYLOCK		
5	57128	8	NUT, 5/16-24 HEX NYLOCK		
6	62714	2	PLATE, DRIVE AXLE		
7	70266	8	SCR, 3/8-16 X 1.00 HHCS GR5		
8	70325	4	SCR, 5/16-18 X 1.25 HHCS GR5		
9	87003	8	WASHER, 3/8 X 7/8 FLAT SS		
10	87090	4	WASHER, 1/4 ID X 3/4 OD PLTD		
11A	89155	2	WHEEL, 10" PNEU. NON-MARKING		(STANDARD)
	78414	-	TUBE, 10" TIRE		(NOT SHOWN)
11B	89175	-	WHEEL ASY, 10IN PNEU, BLACK		(OPTION)
	78414	-	TUBE, 10" TIRE		(NOT SHOWN)
11C	830748	-	WHEEL ASM, 10" SOLID SPCL SCBR		
11D	89211	-	WHEEL ASM, 10" FMFL N-MARKING		
11E	89212	-	WHEEL ASM, 10" FMFL BLK KNOBBY		
12	89190	1	WELDMENT, FRAME		

WIRING GROUP - BATTERY CABLES

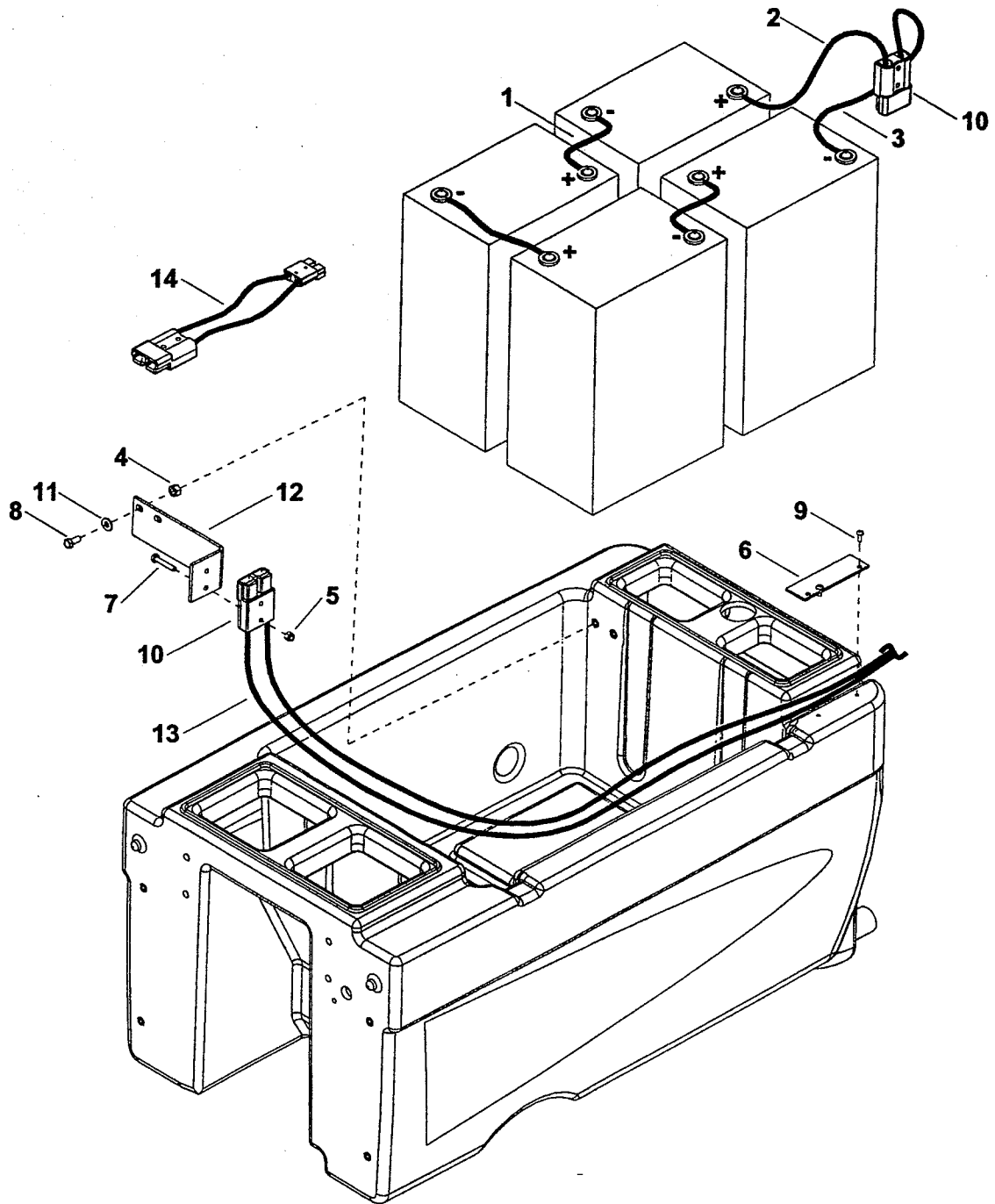

WIRING GROUP – BATTERY CABLES

REF	PART NO.	QTY	DESCRIPTION	SERIAL NO. FROM	NOTES:
1	23125	3	WIRE, 4 X 15 B CLAMP		
2	23190	1	CABLE, 4 X 27 RED		
3	23191	1	CABLE, 4 X 27 BLK		
4	57111	2	NUT, 3/8-16 HEX		
5	57245	2	NUT, 1/4-20 HEX NYLOCK SS		
6	62728	1	PLATE, CABLE MOUNT		
7	70010	2	SCR, 1/4-20 X 1.5 HHCS SS		
8	70302	2	SCR, 5/16-18 X 1"HHCSGR5PLT DL		
9	70403	2	SCR, #10X1/2 PPHST TYPE B		
10	82803	2	CONNECTOR, RED 24V		
11	87029	2	WASHER, 5/16 FLAT SS		
12	140322	1	BRKT, BATT CONNECTOR MOUNTING		
13	880208	2	CABLE, ELECTRICAL 4GA X 80.0		
14	880209	1	WIRE ASM, CHARGER ADAPTER 24V		

WIRING GROUP - CONTROL PANEL

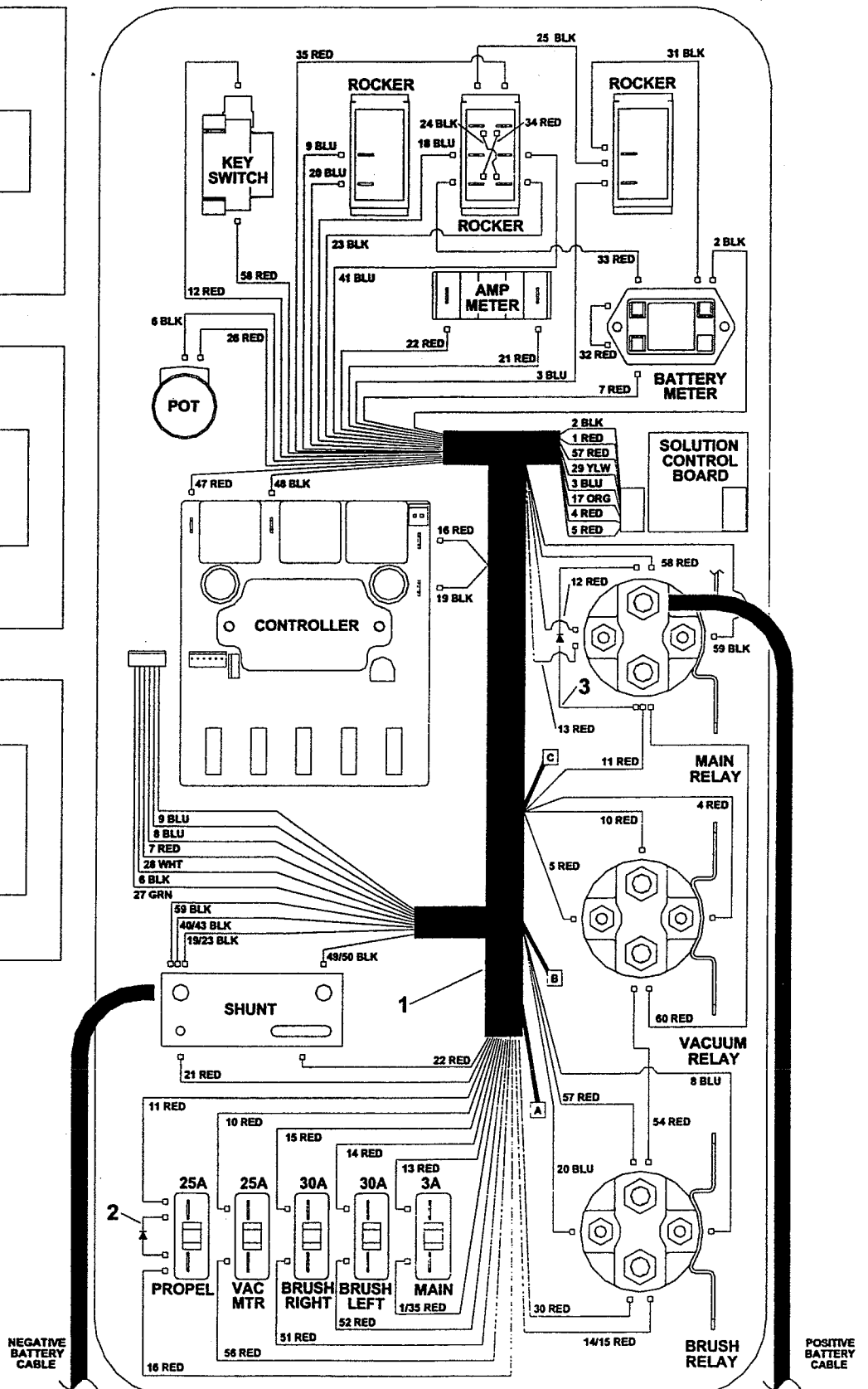
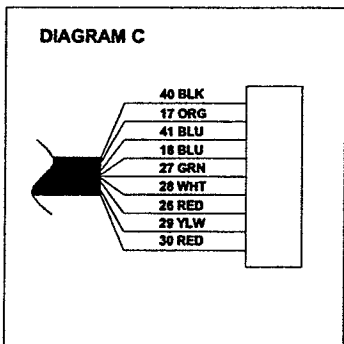
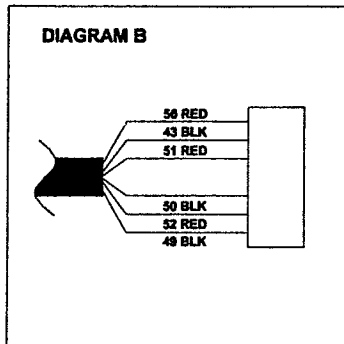
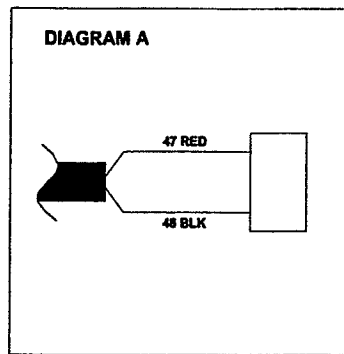

WIRING GROUP - CONTROL PANEL

REF	PART NO.	QTY	DESCRIPTION	SERIAL NO. FROM	NOTES:
1	41360	1	HARNESS, PANEL		
2	29204	1	DIODE ASM, 76008 X 76008		
3	29215	1	DIODE ASM, 76075 X 76075		

WIRING GROUP – MAIN HARNESS

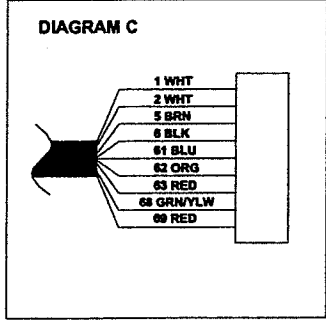
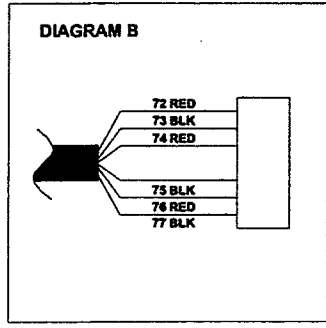
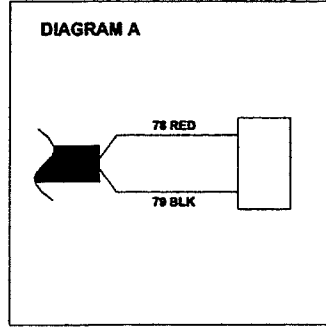
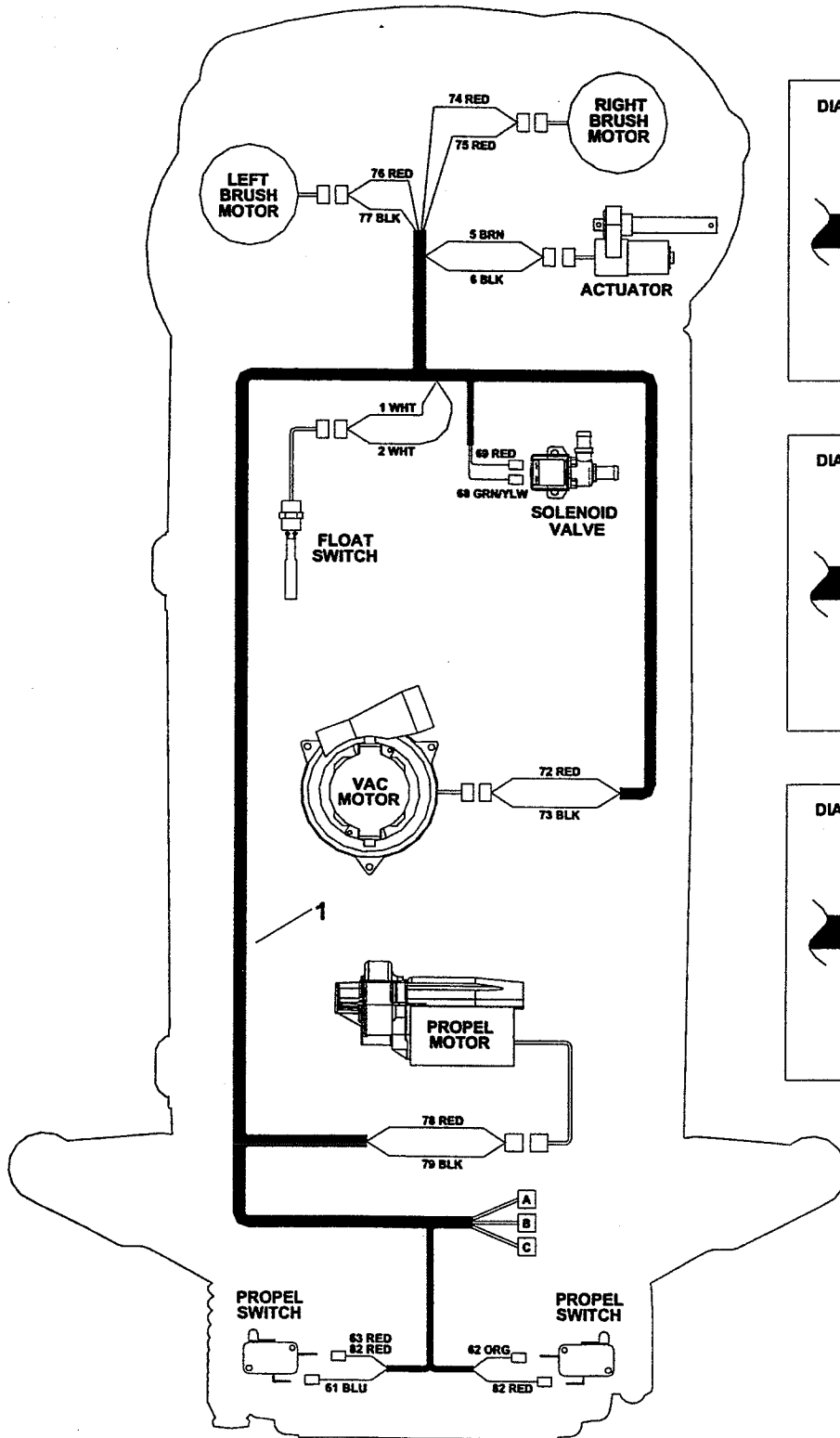

WIRING GROUP – MAIN HARNESS

REF	PART NO.	QTY	DESCRIPTION	SERIAL NO. FROM	NOTES:
1	41359	1	HARNESS, MAIN		

WIRING GROUP - SCHEMATIC

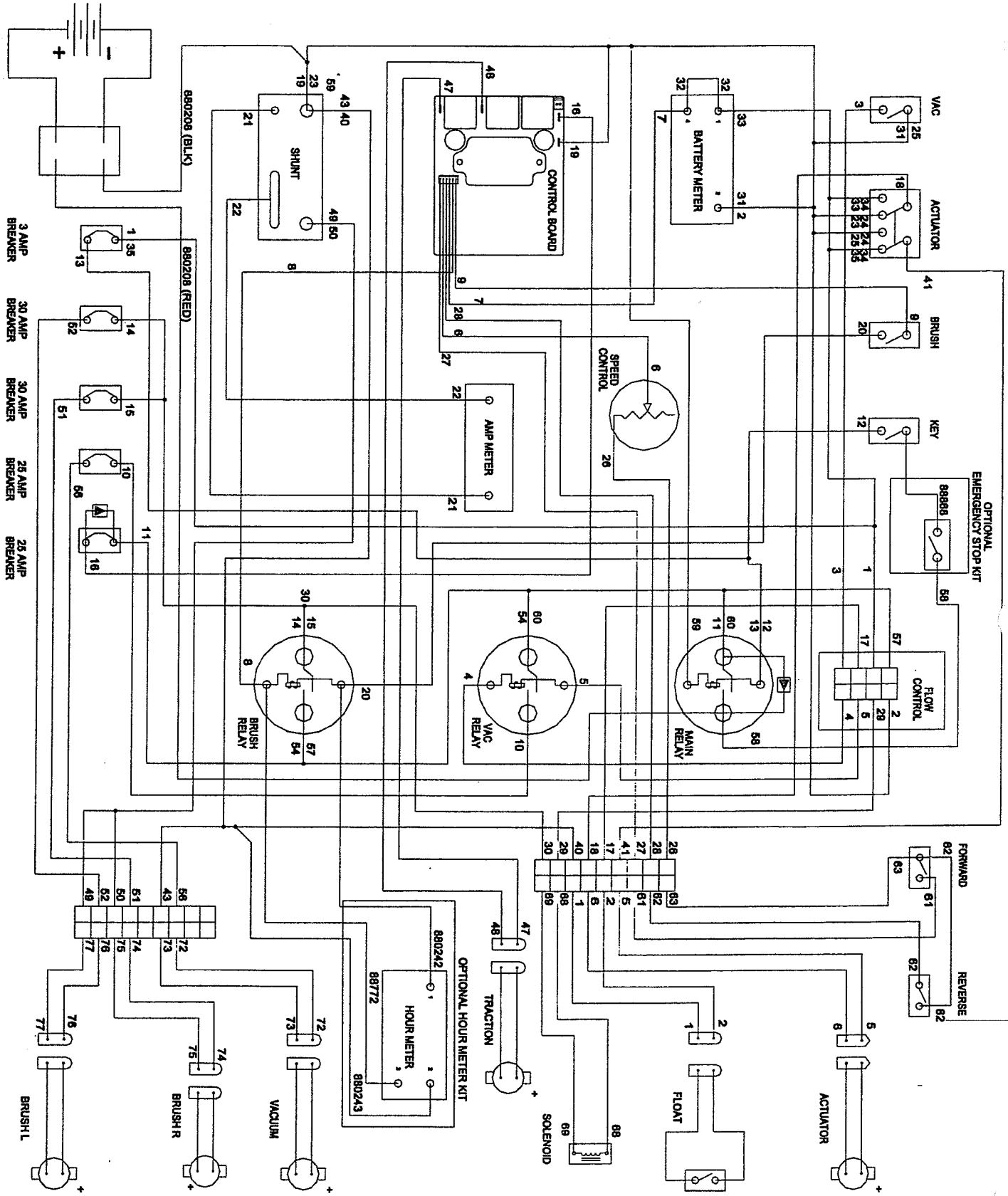

SUGGESTED SPARE PARTS

PART NO.	DESCRIPTION	SERIAL NO.	NOTES:
14606	BREAKER, 30A 50VDC		
14717	BREAKER, 3A		
29119	DRIVER, BRUSH		
35122	GASKET, 230V VAC MOTOR		
35211	GASKET, 8.50 X 16.40		
35212	GASKET, 6.30 X 16.10		
67393	RELAY, 24VDC 100A		
72093	SWITCH, 125VDC SPST		
72130	SWITCH, SPST 2-POSITION ROCKER		
72165	SWITCH, DPDT 3-POSITION ROCKER		
73938	SPRING, EXTENSION		
81535	KNOB		
82017	FILTER, SCREEN		
73976	BLADE, SQUEEGEE REAR LINATEX		
73894	BLADE, SQUEEGEE FRONT LINATEX		

NOTES:

BRAKE OPTION

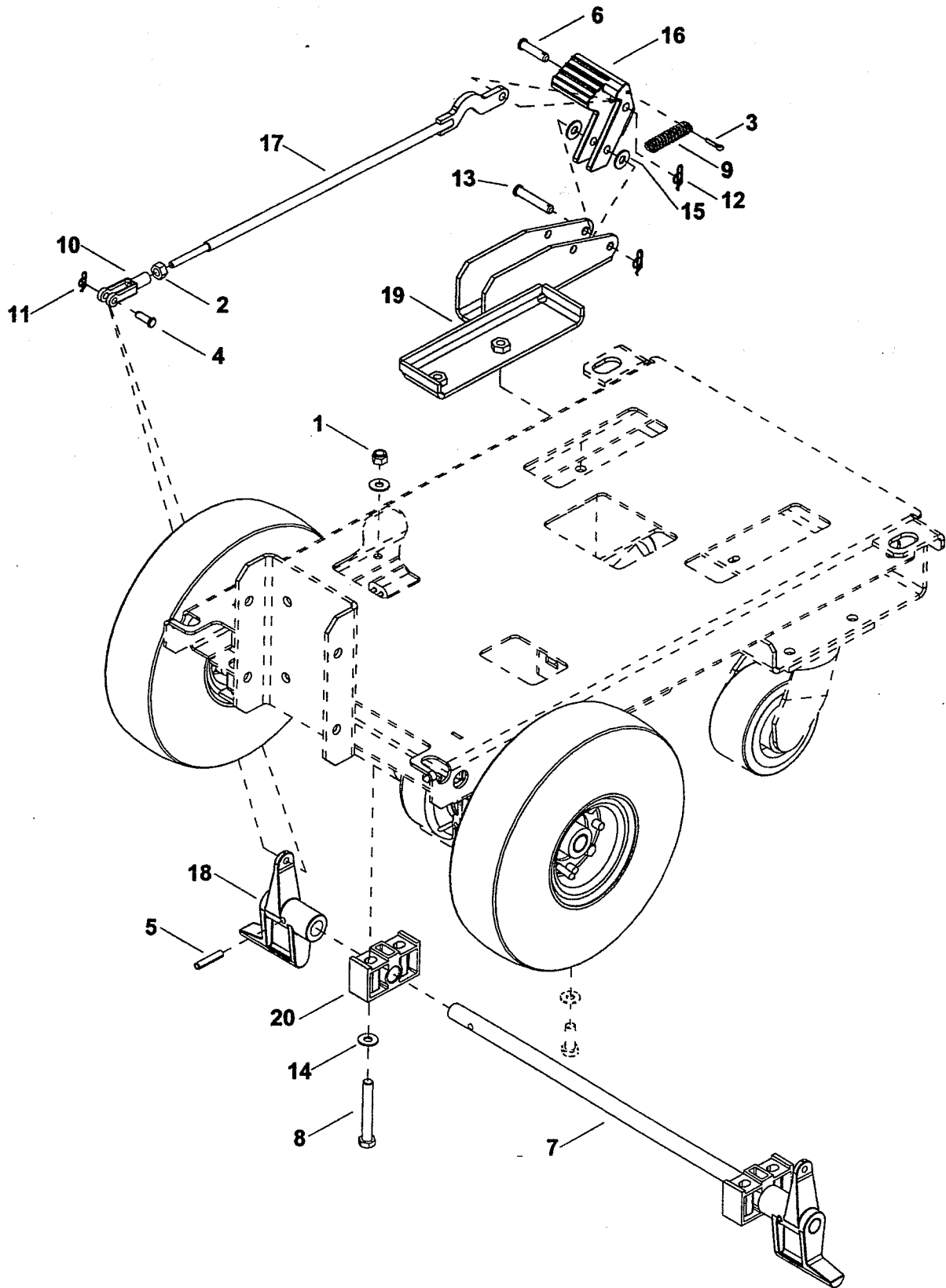

BRAKE OPTION

REF	PART NO.	QTY	DESCRIPTION	SERIAL NO. FROM	NOTES:
1	57113	4	NUT, 5/16-18 HEX NYLOCK		
2	57029	1	NUT, 1/4-28 HEX SS		
3	66073	1	PIN, COTTER 1/16" X 3/4" L PLTD		
4	66116	1	PIN, CLEVIS 1/4" X 3/4" PLTD		
5	66192	2	PIN, ROLL 1/4 X 1.25L		
6	66304	1	PIN, CLEVIS 5/16 X 1-1/4		
7	67400	1	ROD, TORSION BRAKE		
8	70349	4	SCR, 5/16-18 X 2.5 HHCS		
9	73426	1	SPRING, EXT .43D X2.50L X.047W		
10	80603	1	CLEVIS, 1/4" YOKE END 1/4-28		
11	80604	1	COTTER, 1/4" RING		
12	80605	2	COTTER, 5/16" RING		
13	80831	1	PIN, CLEVIS 5/16" X 1.75" L PLT		
14	87029	4	WASHER, 5/16 FLAT SS		
15	87030	2	WASHER, 3/8 ID X 3/4 OD NYLON		
16	89151	1	PEDAL, BRAKE		
17	89152	1	WELDMT, ROD PRK. BRAKE		
18	89153	2	PAD, BRAKE		
19	89196	1	WELDMENT, BRAKE PEDAL		
20	140331	2	BUSHING, PILLOW BLOCK		

EMERGENCY STOP OPTION

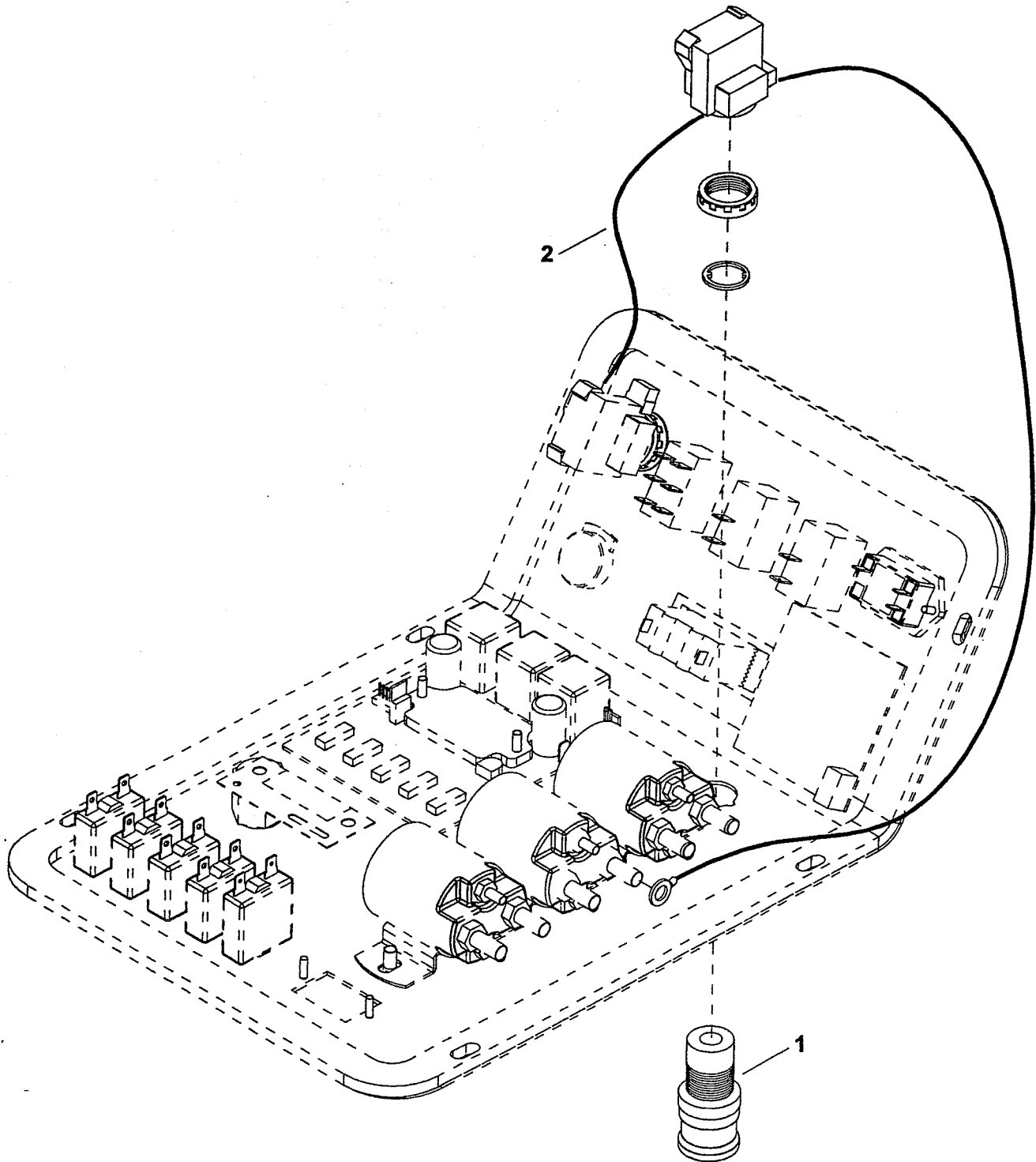

EMERGENCY STOP OPTION

REF	PART NO.	QTY	DESCRIPTION	SERIAL NO. FROM	NOTES:
1	72160	1	SWITCH, EMERGENCY STOP		
2	88868	1	WIRE, 16" RED/18 STRIP X STRIP		

HOUR METER OPTION

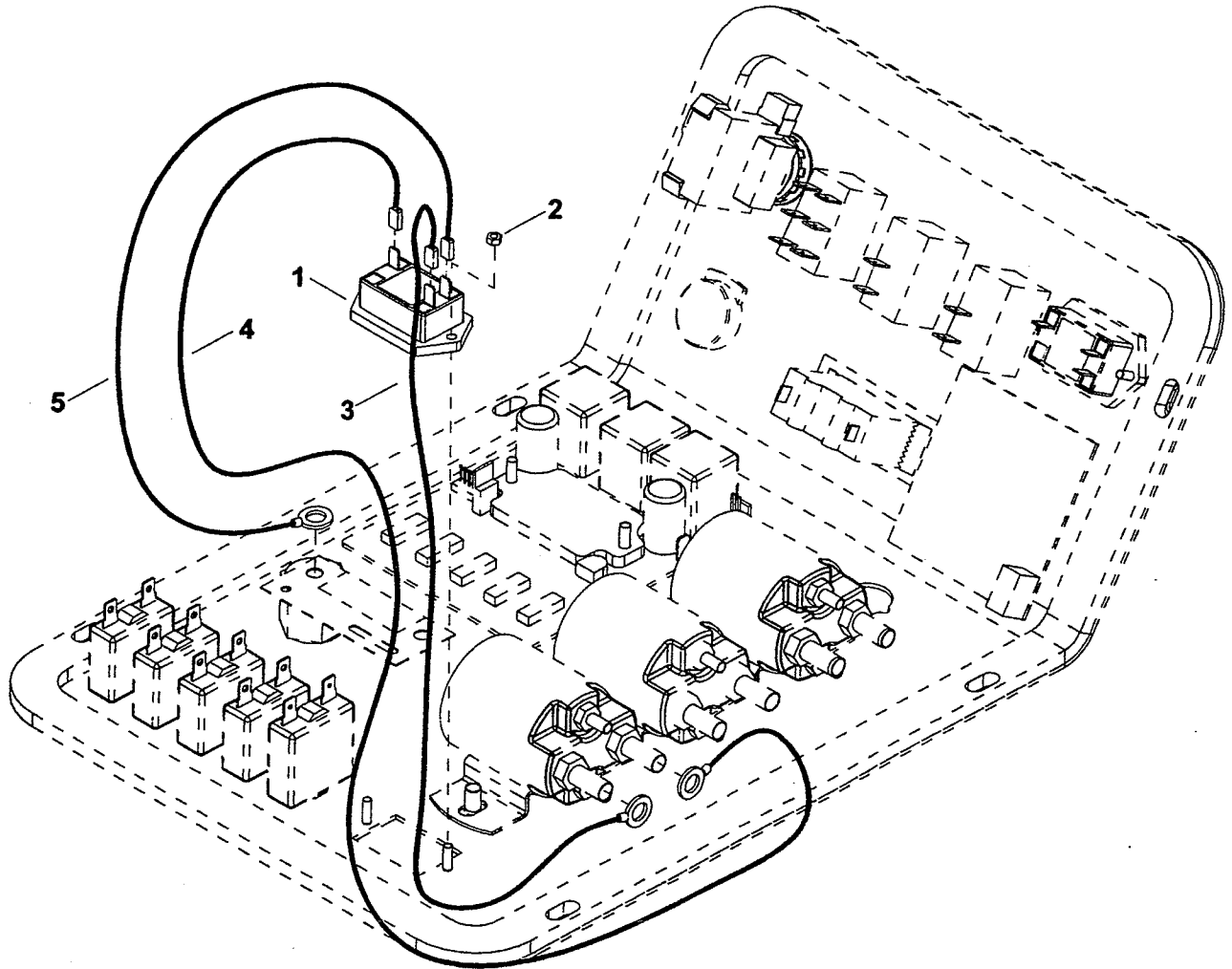

HOUR METER OPTION

REF	PART NO.	QTY	DESCRIPTION	SERIAL NO. FROM	NOTES:
1	54154	1	METER, 12-48 VDC LED HOUR		
2	57078	2	NUT, 4-40 HEX		
3	88772	1	WIRE, 6" RED/18 76075 X 76114		
4	880242	1	WIRE, 9" RED/18 76075 X 76114		
5	880243	1	WIRE, 9" BLK/18 76011 X 76114		

QUICK SCRUBHEAD CONNECT OPTION

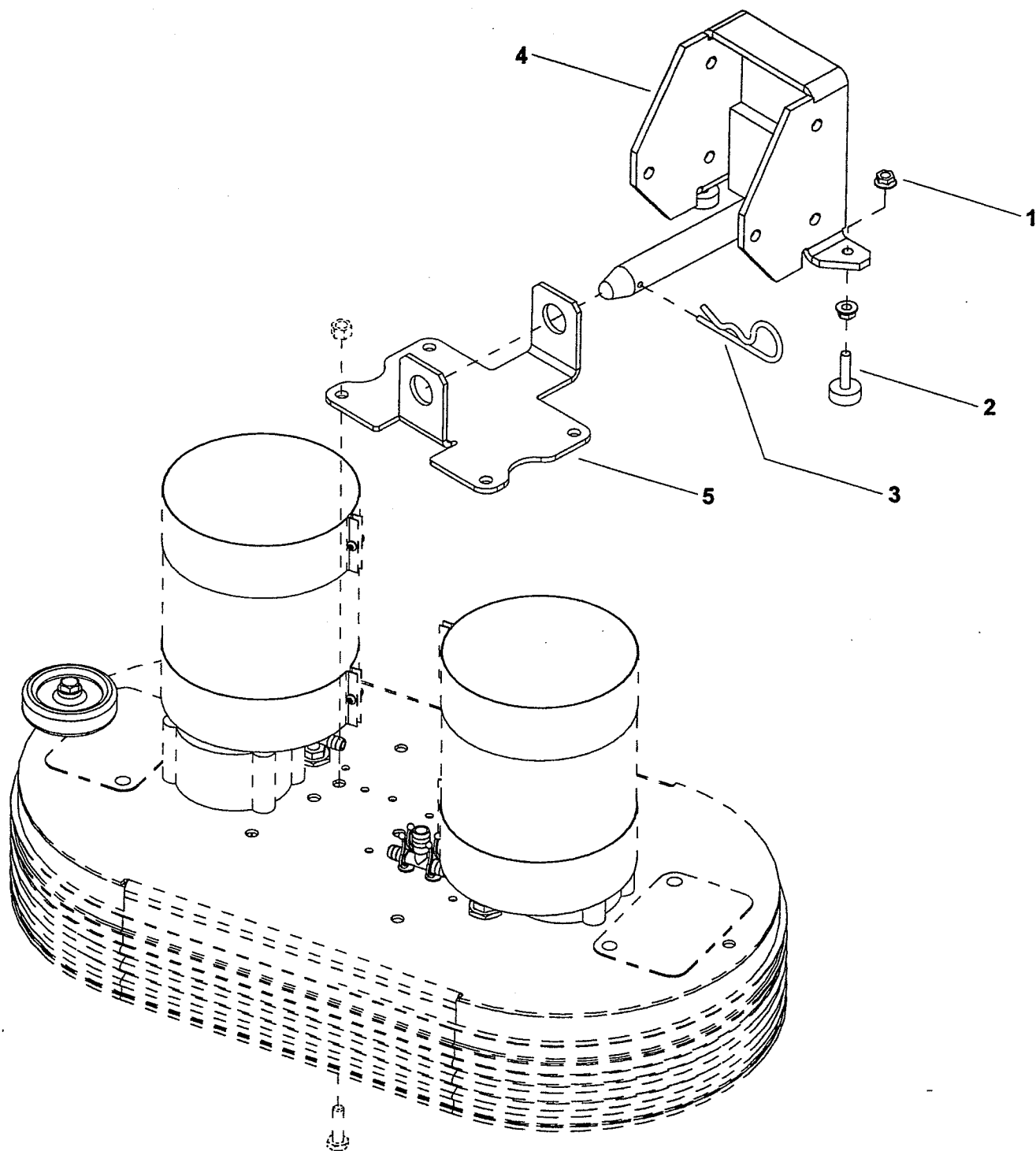

QUICK SCRUBHEAD CONNECT OPTION

REF	PART NO.	QTY	DESCRIPTION	SERIAL NO. FROM	NOTES:
1	57112	4	NUT, 5/16-18 SERRATED FLG		
2	80654	2	BUMPER, ADJUSTMENT		
3	82191	1	PIN, COTTER HAIR .178 DIA X 1"		
4	89121	1	WELDMENT, SCRUB DECK PIN		
5	140389	1	BRKT, SCRUB HEAD MOUNT		

SMART SQUEEGEE OPTION – 24 IN & 26 IN

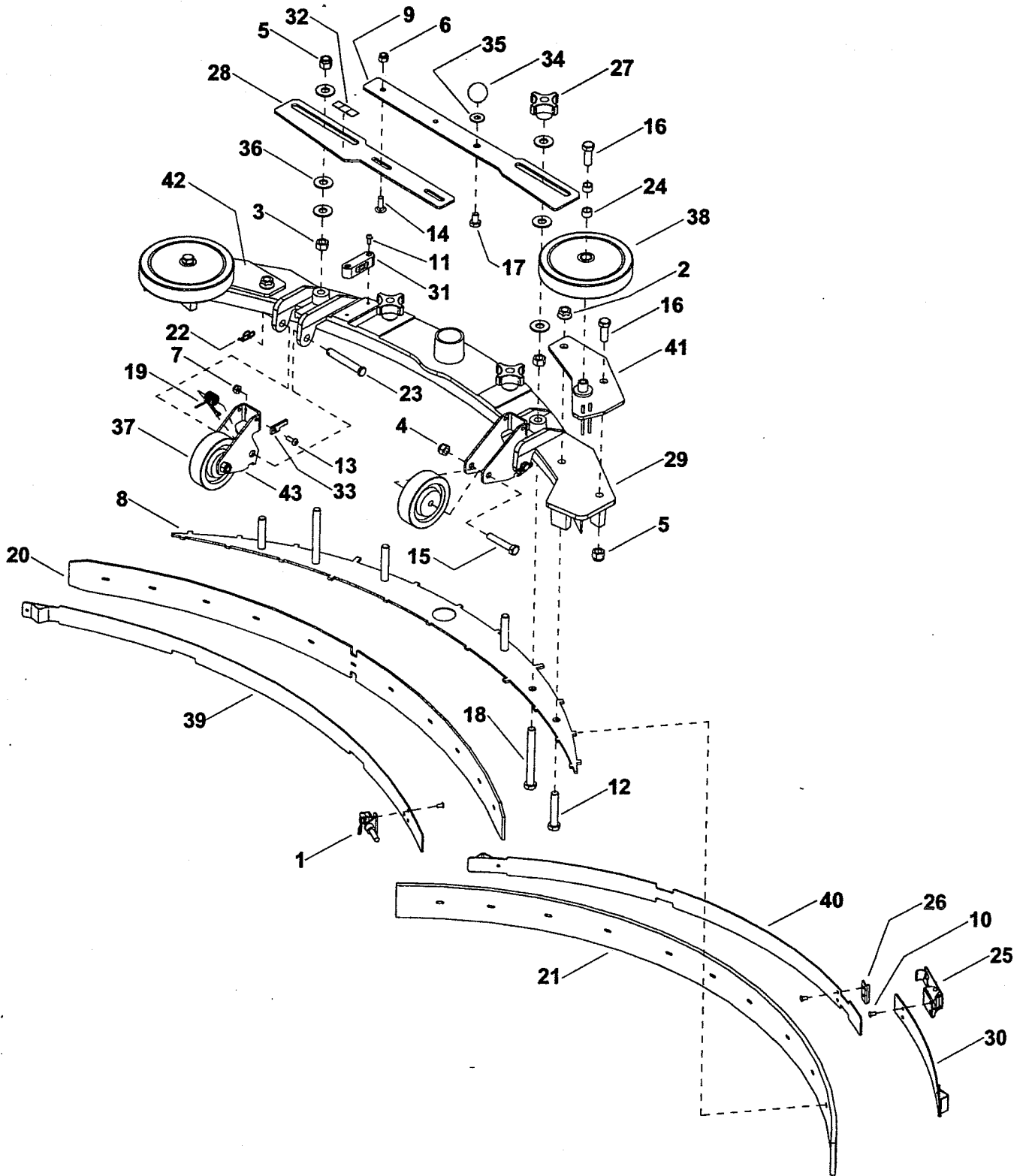

SMART SQUEEGEE OPTION - 24 IN & 26 IN

REF	PART NO.	QTY	DESCRIPTION	SERIAL NO. FROM	NOTES:
1	27797	1	CLAMP, STRAIGHT LINE MANUAL		
2	57032	2	NUT, 3/8-16 HEX NYLOCK THIN SS		
3	57111	2	NUT, 3/8-16 HEX		
4	57113	2	NUT, 5/16-18 HEX NYLOCK		
5	57119	3	NUT, 3/8-16 HEX NYLOCK SS		
6	57245	2	NUT, 1/4-20 HEX NYLOCK SS		
7	57252	1	NUT, 10-24 X 1/2 PHMS SS		
8	62675	1	PLATE, SQUEEGEE RETAINER BLADE		
9	62684	1	PLATE, SQUEEGEE ADJUST LONG		
10	67380	7	RIVET, 5/32 OD X 1/8 GRIP		
11	70052	2	SCR, 8-32 X 3/8 PPHMS SS		
12	70070	2	SCR, 3/8-16 X 2.00 HHCS SS		
13	70086	1	SCR, 10-24 X 1/2 PHMS SS		
14	70112	2	SCR, 1/4-20 X 3/4 CARRIAGE		
15	70259	2	SCR, 5/16-18 X 1.75 HHCS		
16	70266	4	SCR, 3/8-16 X 1.00 HHCS GR5 PLT DL		
17	70375	1	SCR, 5/16-18 X 1/2 HHCS GR5		
18	70461	2	SCR, 3/8-16 X 3.50 HHCS GR5 PLTD		
19	73887	2	SPRING, 120 DEGREE TORSION		
20	73975	1	SQGE BLADE, REAR STD 40		(STANDARD)
	73976	-	SQUEEGEE, REAR BLADE LINATEX		(OPTION)
	73977	-	SQUEEGEE, REAR BLADE (TILE)		(OPTION)
	73978	-	SQUEEGEE, REAR BLADE (BUTTONS)		(OPTION)
21	73931	1	SQGE BLADE, FRONT STD 35"		(STANDARD)
	73894	-	SQGE BLADE, FRONT LINATEX 35"		(OPTION)
	73898	-	SQGE BLADE, FRONT (TILE) 35"		(OPTION)
	73896	-	SQGE BLADE, FRONT (BUTTONS) 35"		(OPTION)
22	80606	2	COTTER, 3/8 RING		
23	80637	2	PIN, CLEVIS 3/8 X 2.38		
24	81247	4	SPACER, .500 OD X .391 ID X .300		
25	81488	1	LATCH, SQUEEGEE STRAP		
26	81489	1	STRIKER, SQUEEGEE STRAP REAR		
27	81535	3	KNOB, SQUEEGEE ADJ. PLATE		
28	82531	1	PLATE, SQUEEGEE ADJUST SHORT		
29	82535	1	SQUEEGEE, 32 IN		
30	82553	1	WELDMENT, REAR SQG. BAND SHORT		
31	82576	1	VIAL, LEVEL		
32	82644	1	OVERLAY, SQUEEGEE		
33	82799	1	PLATE, POINTER		
34	82922	1	BALL, KNOB ADJ.		
35	87029	1	WASHER, 5/16 X 3/4 SS		
36	87143	6	WASHER, 7/16 X 1" FLAT		
37	89095	2	WHEEL, 3" DIA. CUSHION RUBBER		
38	89086	2	WHEEL, 5"D X 1" X .5"ID GRY		
39	89123	1	WELDMENT, FRONT SQUEEGEE BAND		
40	89125	1	WELDMENT, BAND REAR-LONG		
41	89163	1	WELDMENT, SQUEEGEE EXT RT		
42	89160	1	WELDMENT, SQUEEGEE EXT LT		
43	140275	2	BRKT, SQUEEGEE WHEEL SUPPORT		

SMART SQUEEGEE OPTION – 28 IN

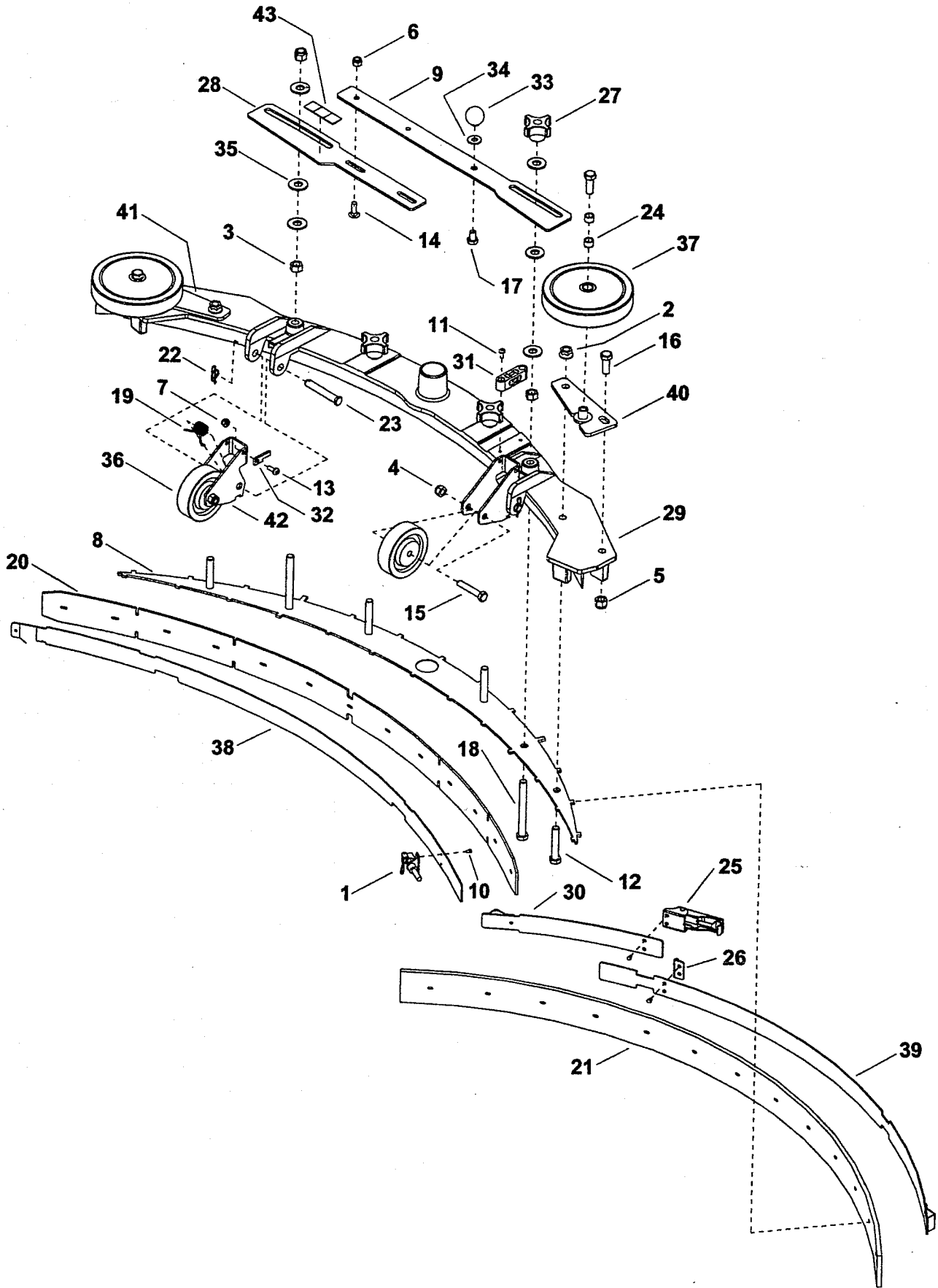

SMART SQUEEGEE OPTION - 28 IN

REF	PART NO.	QTY	DESCRIPTION	SERIAL NO. FROM	NOTES:
1	27797	1	CLAMP, STRAIGHT LINE MANUAL		
2	57032	2	NUT, 3/8-16 HEX NYLOCK THIN SS		
3	57111	2	NUT, 3/8-16 HEX		
4	57113	2	NUT, 5/16-18 HEX NYLOCK		
5	57119	3	NUT, 3/8-16 HEX NYLOCK SS		
6	57245	2	NUT, 1/4-20 HEX NYLOCK SS		
7	57252	1	NUT, 10-24 X 1/2 PHMS SS		
8	82518	1	PLATE, SQUEEGEE BLADE RETAINER		
9	82532	1	PLATE, SLIDE SQUEEGEE LONG		
10	67380	7	RIVET, 5/32 OD X 1/8 GRIP		
11	70052	2	SCR, 8-32 X 3/8 PPHMS SS		
12	70070	2	SCR, 3/8-16 X 2.00 HHCS SS		
13	70086	1	SCR, 10-24 X 1/2 PHMS SS		
14	70112	2	SCR, 1/4-20 X 3/4 CARRIAGE		
15	70259	2	SCR, 5/16-18 X 1.75 HHCS		
16	70266	4	SCR, 3/8-16 X 1.00 HHCS GR5 PLT DL		
17	70375	1	SCR, 5/16-18 X 1/2 HHCS GR5		
18	70461	2	SCR, 3/8-16 X 3.50 HHCS GR5 PLTD		
19	73887	2	SPRING, 120 DEGREE TORSION		
20	73934	1	SQGE BLADE, REAR STD 41"		(STANDARD)
	82529	-	SQGE BLADE, REAR LINATEX 41"		(OPTION)
	82638	-	SQGE BLADE, REAR (TILE) 41"		(OPTION)
	82641	-	SQGE BLADE, REAR (BUTTONS) 41"		(OPTION)
21	73932	1	SQGE BLADE, FRONT STD 39"		(STANDARD)
	82528	-	SQUEEGEE, FRONT BLADE LINATEX		(OPTION)
	82637	-	SQUEEGEE, FRONT BLADE (TILE)		(OPTION)
	82640	-	SQUEEGEE, FRONT BLADE (BUTTON)		(OPTION)
22	80606	2	COTTER, 3/8 RING		
23	80637	2	PIN, CLEVIS 3/8 X 2.38		
24	81247	4	SPACER, .500 OD X .391 ID X .300		
25	81488	1	LATCH, SQUEEGEE STRAP		
26	81489	1	STRIKER, SQUEEGEE STRAP REAR		
27	81535	3	KNOB, SQUEEGEE ADJ. PLATE		
28	82531	1	PLATE, SQUEEGEE ADJUST SHORT		
29	82514	1	SQUEEGEE, 37 INCH		
30	82553	1	WELDMENT, REAR SQG. BAND SHORT		
31	82576	1	VIAL, LEVEL		
32	82799	1	PLATE, POINTER		
33	82922	1	BALL, KNOB ADJ.		
34	87029	1	WASHER, 5/16 X 3/4 SS		
35	87143	6	WASHER, 7/16 X 1" FLAT		
36	89095	2	WHEEL, 3" DIA. CUSHION RUBBER		
37	89086	2	WHEEL, 5"D X 1" X .5"ID GRY		
38	82558	1	WELDMENT, FRONT SQUEEGEE BAND		
39	82525	1	WELDMENT, REAR SQUEEGEE BAND		
40	89164	1	WELDMENT, SQUEEGEE EXT RT		
41	89165	1	WELDMENT, SQUEEGEE EXT LT		
42	140275	2	BRKT, SQUEEGEE WHEEL SUPPORT		
43	82644	1	OVERLAY, SQUEEGEE		

