



## Electronic Service Manuals

This electronic document is provided as a service to our customers. We do not create the contents of the information contained in this document. Should you have detailed questions pertaining to the information contained in this document, you may contact Michco, or the manufacturer which provided the original information in this electronic deliverable. Michco's only part in this electronic deliverable was the electronic assembly process.

You may contact Michco through the following methods:  
Phone (517) 484-9312 or (800) 331-3339 MI, OH, IN only  
2011 N. High St. -- Lansing, Michigan -- 48906  
Fax: (517) 484-9836  
Email: [CustServ@Michco.com](mailto:CustServ@Michco.com)  
Web site: [www.Michco.Com](http://www.Michco.Com)  
Parts Web site: [www.FloorMachineParts.Com](http://www.FloorMachineParts.Com)

Order Parts on Line at:  
**[www.FloorMachineParts.Com](http://www.FloorMachineParts.Com)**

Directly to Parts & Service:  
By Email: **[Shop@Michco.com](mailto:Shop@Michco.com)**  
By Fax: (517) 702-2041  
By Voice: Use numbers above.

**Serving the Cleaning Industry Since 1922**

Notice: All copyrighted material remains property of original owners, all trademarks are property of respective owners. Manuals are subject to Manufacturer's reproduction limitations. Originals or reproductions were provided by manufacturers through a request. We make no warranty as to the correctness of information provided in this document and you assume all risk.

# GD 1000 series

Parts list for model:

|            |           |        |
|------------|-----------|--------|
| GD 1005 -  | 110-120V: | 208700 |
| GD 1010 -  | 110-120V: | 208800 |
| GDS 1010 - | 110-120V: | 208900 |
| HDS 1005 - | 110-120V: | 208600 |

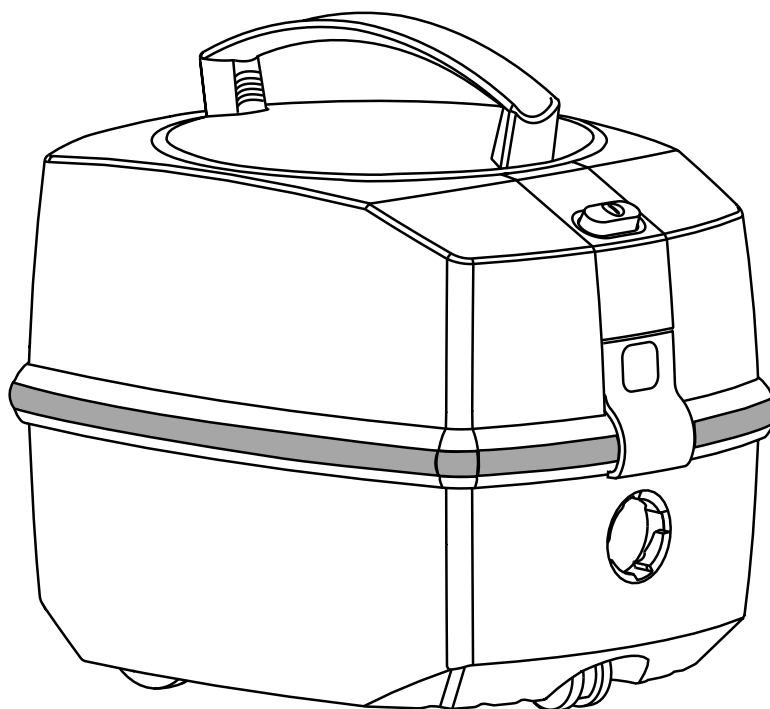

# Nilfisk

Made for ADVANCE

1/99 FORM NUMBER 56042335

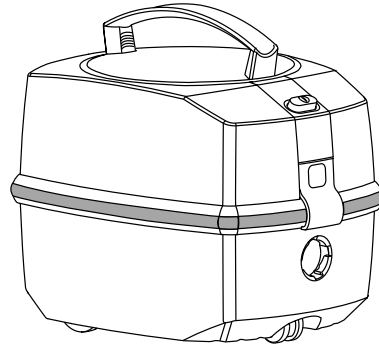

| DESCRIPTION  | PAGE |
|--|------|
| Motors, internal wires and cords                   | 2    |
| Container upper parts                              | 4    |
| Electric switch units                              | 6    |
| Filter and HEPA filter                             | 8    |
| Container bottom parts                             | 10   |
| Nozzles, tubes, hoses,<br>accessories and dust bag | 12   |
| Wiring diagrams                                    | 16   |

**WHEN ORDERING PARTS**

- \* Use the 6 digit numbers from the "Ref. No." columns in this parts list.
- \* Specify the model and serial number of the machine.
- \* Use the space below to record the model and serial number for future reference.

Model \_\_\_\_\_ Serial No. \_\_\_\_\_



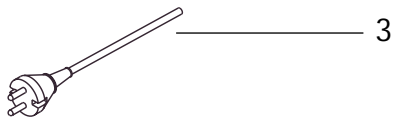
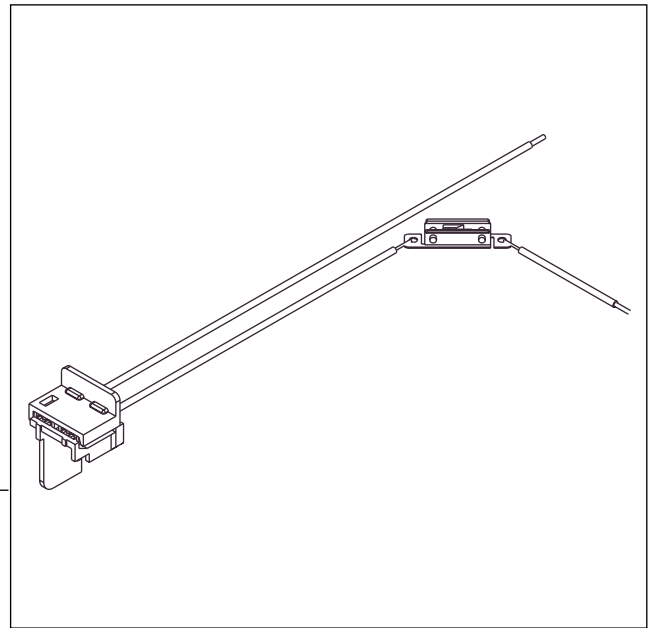
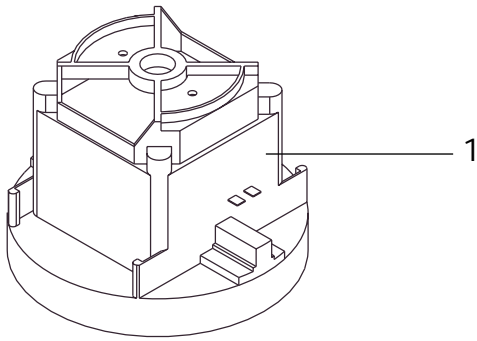

MOTOR SERVICE KIT

2

MOTOR AND CORD TYPES, ALL MODELS



**Fig. 1 Cord**

|                        | Voltage | Plug type   |   |
|------------------------|---------|---|---|
| Index 03,<br>AUS/NZ    | 250     |  |  |
| Index 05,<br>USA/Japan | 120     |  |  |

**MOTOR SERVICE KIT****MOTOR AND CORD TYPES, ALL MODELS****3**

| <b>Item</b> | <b>Ref.No.</b> | <b>Qty</b> | <b>Description</b>                          | <b>Note</b>                                       |
|-------------|----------------|------------|---|---|
| 1           |                |            | Motor/fan unit for:                         | Mat.: Plast and steel                             |
|             | 208601         |            | 220-240 V, 50-60 Hz, 1200 W                 |   |
|             | 208602         |            | 110-120 V, 50-60 Hz, 1000 W                 |   |
| 2a          | 208603         |            | Internal wire kit for<br>GDS 1010, HDS 1005 | Mat.: PVC and copper, PP                          |
| 2b          | 208604         |            | Internal wire kit for<br>GD 1005, GD 1010   | Mat.: PVC and copper, PP                          |
| 3           |                |            | Cord, length = 10 m                         | Mat.: PVC and copper<br>Colour: Grey,<br>RAL 7001 |
|             | 208606         | 1          | Australia, New Zealand                      |   |
|             | 208605         | 1          | USA, Japan, Canada                          |   |

CONTAINERS SERVICE KIT

4

UPPER PARTS, ALL MODELS

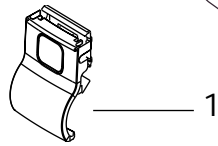
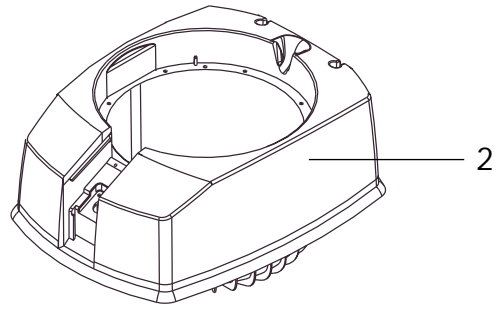
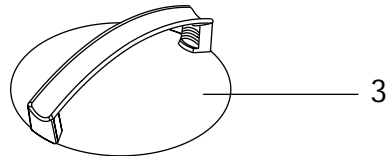

**CONTAINERS SERVICE KIT****UPPER PARTS, ALL MODELS****5**

| <b>Item</b> | <b>Ref.No.</b> | <b>Qty</b> | <b>Description</b> | <b>Note</b>  |
|-------------|----------------|------------|--------------------|--|
| 1           | 208607         | 1          | Lock, assembly     | Mat.: PC and steel, Colour: Grey, RAL 7001/Dark grey, RAL 7016 |
| 2           | 208608         | 1          | Upper part         | Mat.: ABS, Colour: Grey, RAL 7001                              |
| 3           | 208609         | 1          | Handle cover       | Mat.: ABS, Colour: Grey, RAL 7001                              |

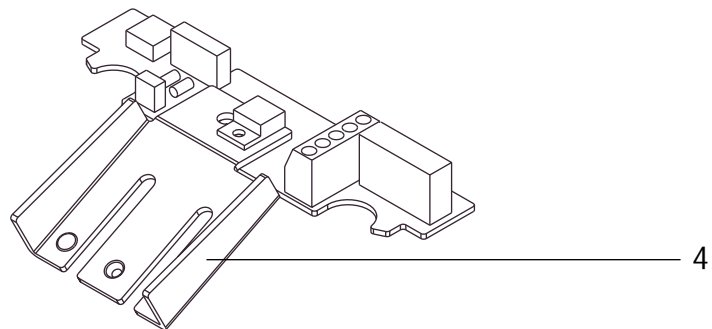
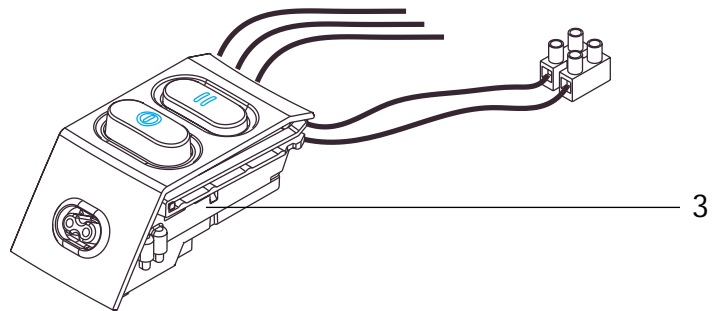
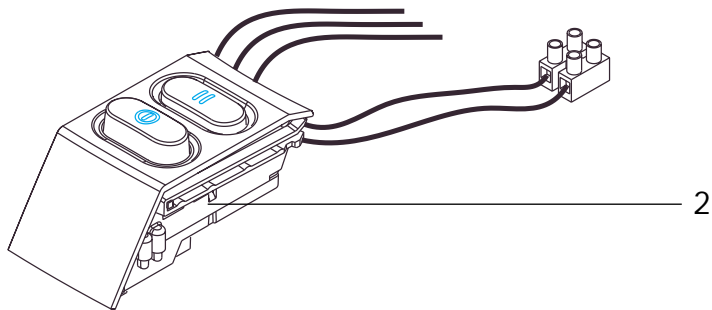
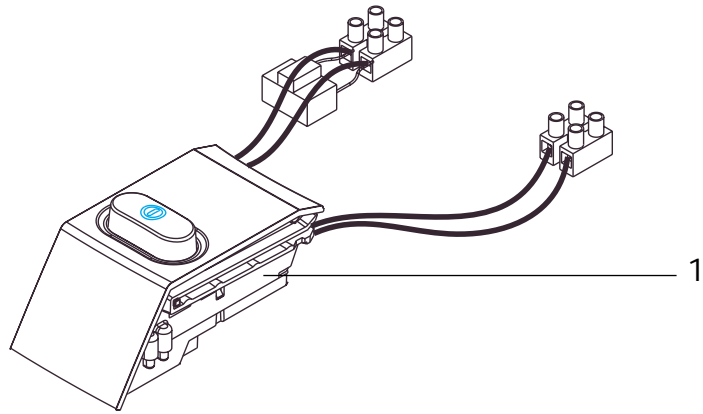

**ELECTRIC SWITCHES SERVICE KIT****ELECTRIC OPERATING SWITCH UNITS****7**

| <b>Item</b> | <b>Ref.No.</b> | <b>Qty</b> | <b>Description</b>                                 | <b>Note</b> |
|-------------|----------------|------------|--|-------------|
| 1           | 208610         | 1          | Electrical unit<br>GD 1005, GD 1010                |             |
| 2           | 208611         | 1          | Electrical unit, GDS 1010                          |             |
| 3           | 208612         | 1          | Electrical unit, HDS 1005                          |             |
| 4           |                |            | Printed wiring board for<br>GDS 1010 and HDS 1005: |             |
|             | 208613         | 1          | 220-240 V, 50 Hz, 1200 W                           |             |
|             | 208614         | 1          | 110-120 V, 60 Hz, 1000 W                           |             |
|             | 208615         | 1          | 100 V, 60 Hz, 1000 W                               |             |

**FILTERS SERVICE KIT**

**8**

**FILTER AND HEPA FILTER**

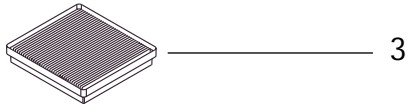
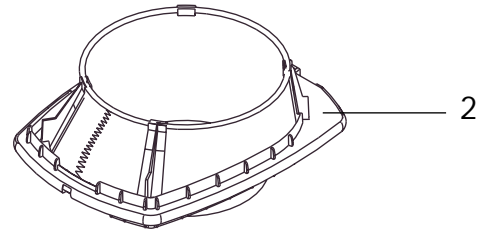
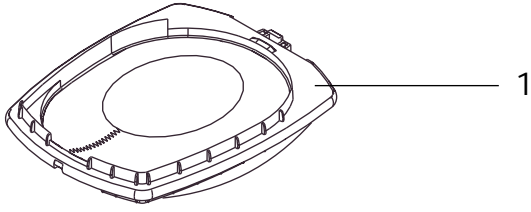

**FILTERS SERVICE KIT****FILTER AND HEPA FILTER****9**

| <b>Item</b> | <b>Ref.No.</b> | <b>Qty</b> | <b>Description</b>             | <b>Note</b>                |
|-------------|----------------|------------|--------------------------------|----------------------------|
| 1           | 208616         | 1          | Filter unit, GD 1005, blue     | Area: 1200 cm <sup>2</sup> |
| 2           | 208617         | 1          | Filter unit, GD 1010, GDS 1010 | Area: 2300 cm <sup>2</sup> |
| 3           | 208618         | 1          | HEPA filter, HDS 1005          | Area: 4300 cm <sup>2</sup> |

CONTAINER SERVICE KIT

10

BOTTOM PARTS

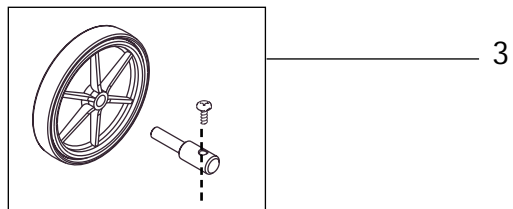
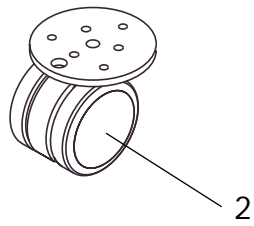
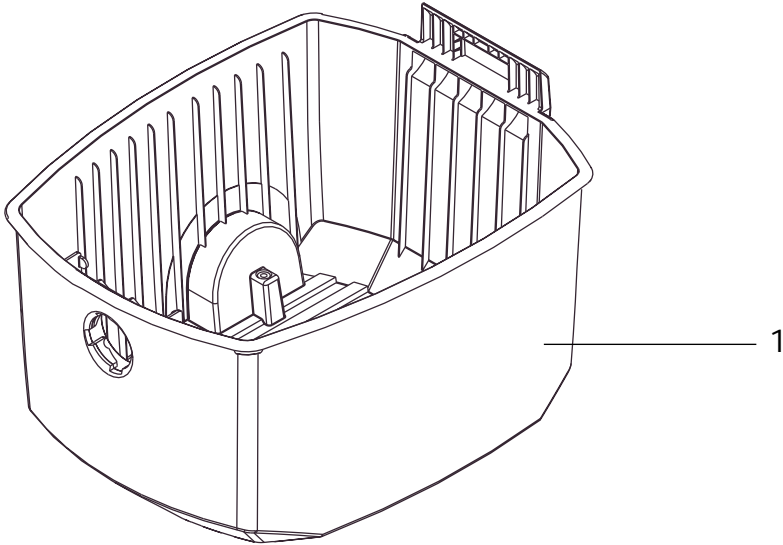

**CONTAINER SERVICE KIT****BOTTOM PARTS****11**

| <b>Item</b> | <b>Ref.No.</b> | <b>Qty</b> | <b>Description</b>                            | <b>Note</b> |
|-------------|----------------|------------|---|-------------|
| 1           | 208619         | 1          | Container, 8.75 litre,<br>GD 1005, HDS 1005   |             |
| 1           | 208621         | 1          | Container, 16 litre<br>GD 1010, GDS 1010      |             |
| 2           | 208622         | 1          | Front wheel with internal<br>plate and screws |             |
| 3           | 208623         | 1          | Wheel   |             |

ACCESSORIES

12

NOZZLES, TUBES, HOSES AND DUST BAGS

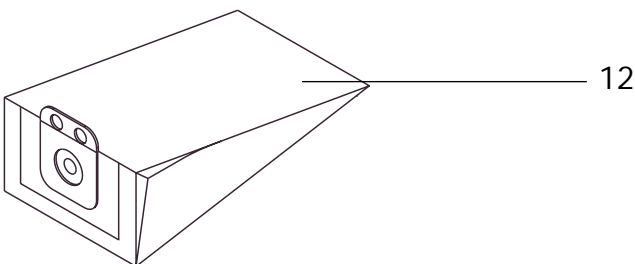
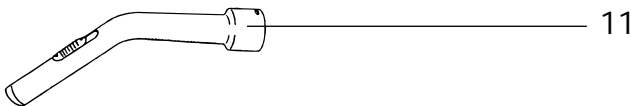
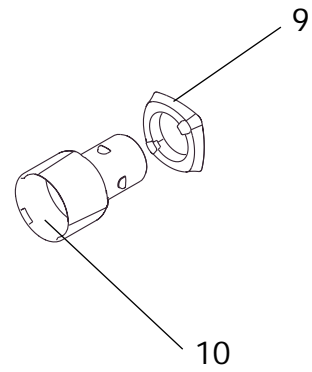
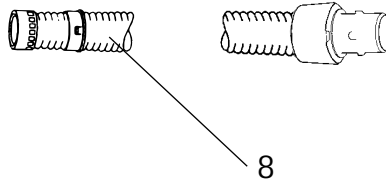
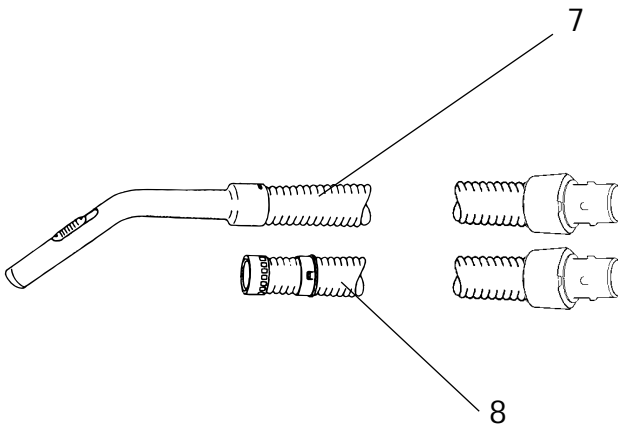
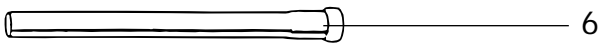
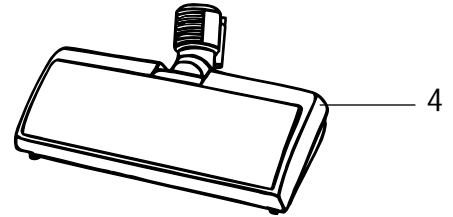
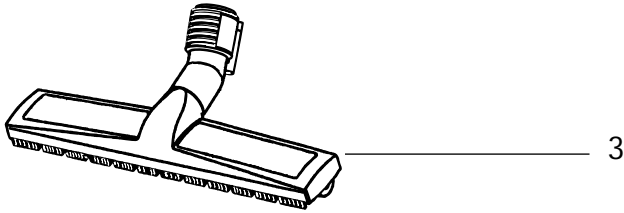
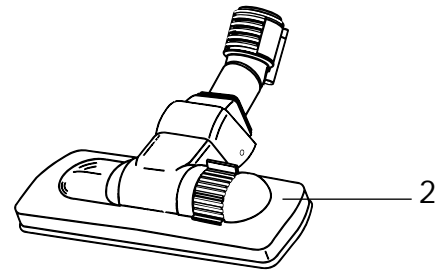
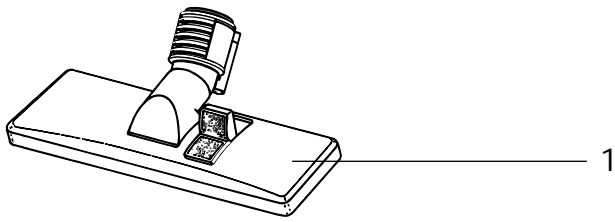

**ACCESSORIES**

**NOZZLES, TUBES, HOSES AND DUST BAGS**

**13**

| Item | Ref.No. | Qty | Description  | Note   |
|------|---------|-----|--|--|
| 1    | 208624  | 1   | Combi dry nozzle with parking clip, 3132                       | Mat.: PP<br>Colour: Grey, RAL 7001<br>Width: 306 mm      |
| 2    | 208625  | 1   | Roller combi dry nozzle with parking clip, 3032                | Mat.: PP<br>Colour: Grey, RAL 7001<br>Width: 294 mm      |
| 3    | 208626  | 1   | Hard floor nozzle with stationary brush and parking clip, 3632 | Mat.: PP<br>Colour: Grey, RAL 7001<br>Width: 360 mm      |
| 4    | 208627  | 1   | Electro nozzle with parking clip, 2832, 220-240 V              | Mat.: PA, ABS<br>Colour: Grey, RAL 7001<br>Width: 280 mm |
| 5    | 208628  | 1   | Parking clip   | Mat.: POM<br>Colour: Grey, RAL 7001                      |
| 6    | 208629  | 1   | Tube   | Mat.: Steel<br>Length: 560 mm                            |
| 7    | 208630  | 1   | Tapered hose with ø 32 mm curved plast tube, 2 m               | Mat.: PP, PE<br>Colour: Silver                           |
| 8    | 208631  | 1   | Tapered hose with coupling only                                | Mat.: PP, PE<br>Colour: Silver                           |
| 9    | 208632  | 1   | Gasket   | Mat.: EPDM<br>Colour: Black                              |
| 10   | 208633  | 1   | Hosecoupler  | Mat.: PC<br>Colour: Dark grey, RAL 7016                  |
| 11   | 208634  | 1   | Curved ø 32 mm plast tube                                      | Mat.: PP with steelfibers<br>Colour: Grey, RAL 7001      |
| 12   | 208638  | 1   | Dust bag (4.5 l), packed with 5 pcs. in a plast bag            | Mat.: Paper unbleached<br>Colour: Brown                  |
|      | 208640  | 1   | 50 pcs. in a carton  |  |
|      | 208641  | 1   | Dust bag (9.5 l), packed with 5 pcs. in a plast bag            |  |
|      | 208642  | 1   | 50 pcs. in a carton  |  |
|      | 208643  | 1   | (4.5 l) 250 pcs. in a carton                                   |  |
|      | 208644  | 1   | (9.5 l) 250 pcs. in a carton                                   |  |

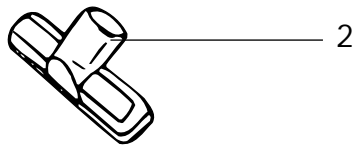
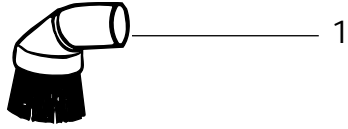

Cloth filter bag ————— 4

Bag clip ————— 5

Cord hook ————— 6

Turbo powered floor tool — 7

**ACCESSORIES****15**

| <b>Item</b> | <b>Ref.No.</b> | <b>Qty</b> | <b>Description</b>       | <b>Note</b> |
|-------------|----------------|------------|--------------------------|-------------|
| 1           | 208636         | 1          | Dusting tool, ø 70 mm    |             |
| 2           | 208637         | 1          | Upholstery tool          |             |
| 3           | 208635         | 1          | Crevice tool             |             |
| 4           | 208645         | 1          | Cloth filter bag         |             |
| 5           | 330608         | 1          | Bag clip                 |             |
| 6           | 208646         | 1          | Cord hook                |             |
| 7           | 100687         | 1          | Turbo powered floor tool |             |

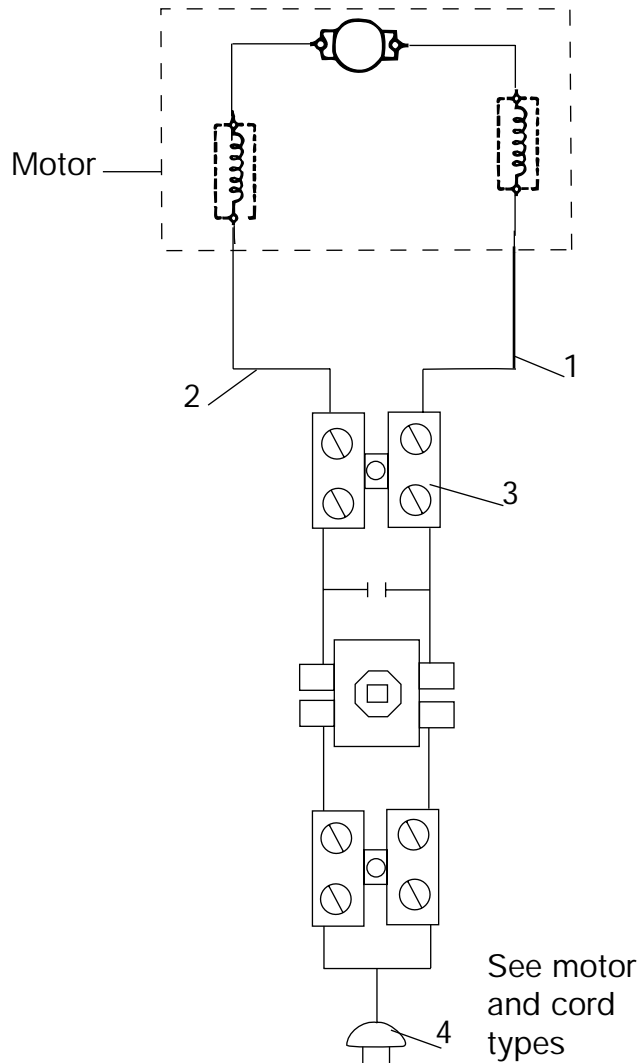

| No. | Part name  |
|-----|--|
| 1   | Internal wire with thermo switch (white, 590 mm, connection: 4.8 x 0.5 mm, $\varnothing$ 1.8 x 6 mm) |
| 2   | Internal wire (brown, 260 mm, connection 4.8 x 0.5 mm, $\varnothing$ 1.8 x 6 mm)                     |
| 3   | Switch incl. terminal blocks, complete   |
| 4   | Cord (grey, length: 10 m)  |

| Symbol explanation |            |           |                |                    |      |
|--------------------|------------|-----------|----------------|--------------------|------|
|                    |            |           |                |                    |      |
| Armature           | Field coil | Capacitor | Terminal block | Double pole switch | Cord |

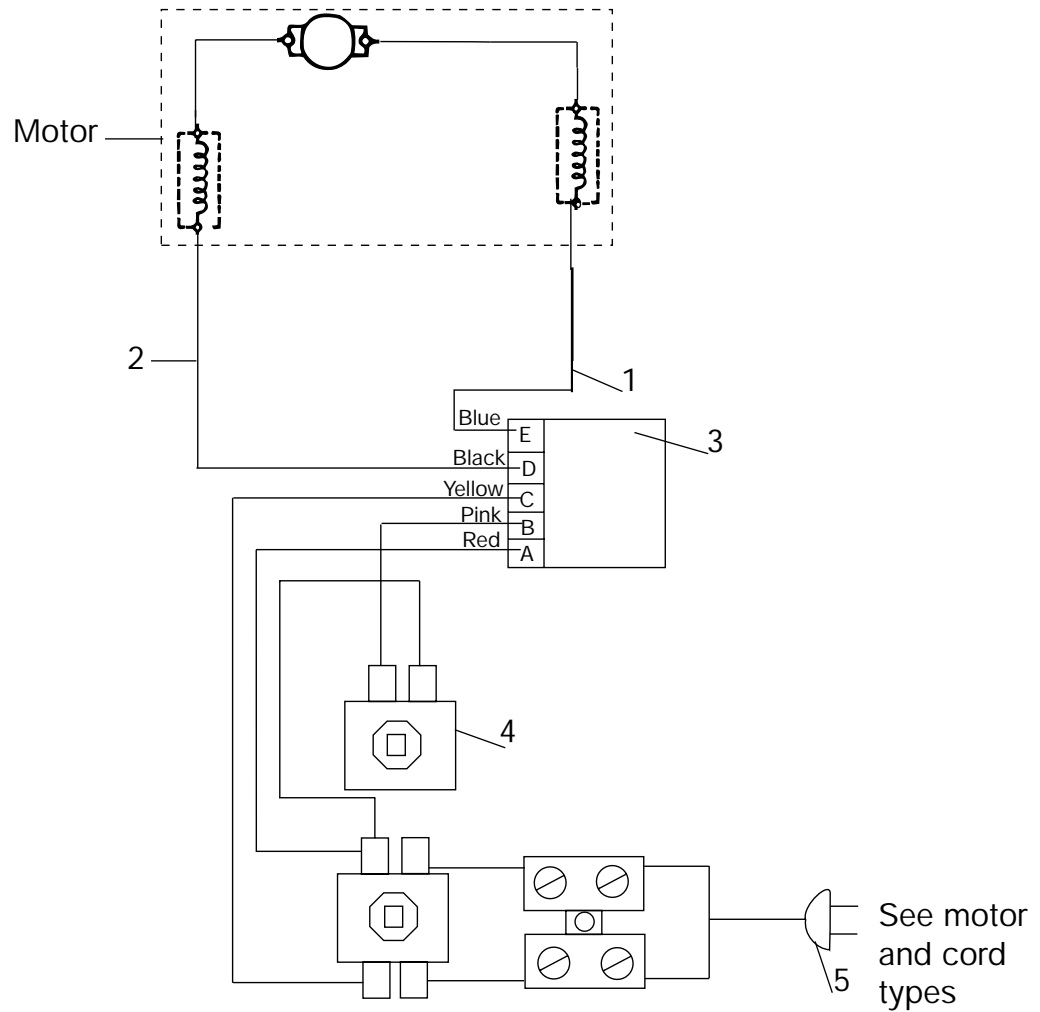

**No. Part name**

|   |   |
|---|---|
| 1 | Internal wire with thermo switch (blue, 785 mm, connection: 4.8 x 0.5 mm, $\varnothing$ 1.8 x 6 mm) |
| 2 | Internal wire (black, length: 420 mm, connection 4.8 x 0.5 mm, $\varnothing$ 1.8 x 6 mm)            |
| 3 | Printed circuit board, included capacitor   |
| 4 | Switch unit for speed regulation  |
| 5 | Cord (grey, length: 10 m)   |

**Symbol explanation**

|          |            |                |      |                       |                    |                    |
|----------|------------|----------------|------|-----------------------|--------------------|--------------------|
|          |            |                |      |                       |                    |                    |
| Armature | Field coil | Terminal block | Cord | Printed circuit board | Single pole switch | Double pole switch |

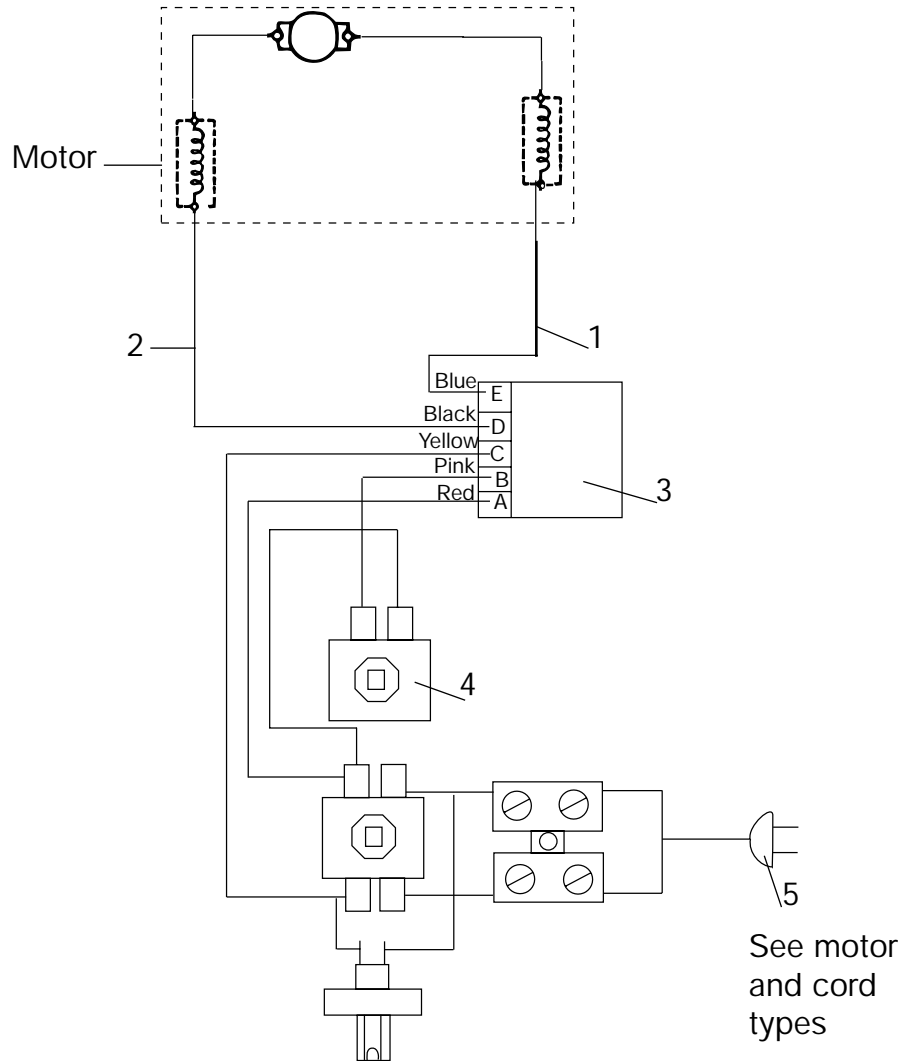

| No. | Part name   |
|-----|---|
| 1   | Internal wire with thermo switch (blue, 785 mm, connection: 4.8 x 0.5 mm, ø 1.8 x 6 mm) |
| 2   | Internal wire (black, length: 420 mm, connection 4.8 x 0.5 mm, ø 1.8 x 6 mm)            |
| 3   | Printed circuit board, included capacitor   |
| 4   | Switch with outlet, complete  |
| 5   | Cord (grey, length: 10 m)   |

| Symbol explanation |            |      |        |                       |                    |                    |
|--------------------|------------|------|--------|-----------------------|--------------------|--------------------|
|                    |            |      |        |                       |                    |                    |
| Armature           | Field coil | Cord | Outlet | Printed circuit board | Single pole switch | Double pole switch |
|                    |            |      |        |                       |                    |                    |
| Terminal block     |            |      |        |                       |                    |                    |

