



## Electronic Service Manuals

This electronic document is provided as a service to our customers. We do not create the contents of the information contained in this document. Should you have detailed questions pertaining to the information contained in this document, you may contact Michco, or the manufacturer which provided the original information in this electronic deliverable. Michco's only part in this electronic deliverable was the electronic assembly process.

You may contact Michco through the following methods:  
Phone (517) 484-9312 or (800) 331-3339 MI, OH, IN only  
2011 N. High St. -- Lansing, Michigan -- 48906  
Fax: (517) 484-9836  
Email: [CustServ@Michco.com](mailto:CustServ@Michco.com)  
Web site: [www.Michco.Com](http://www.Michco.Com)  
Parts Web site: [www.FloorMachineParts.Com](http://www.FloorMachineParts.Com)

Order Parts on Line at:  
**[www.FloorMachineParts.Com](http://www.FloorMachineParts.Com)**

Directly to Parts & Service:  
By Email: **[Shop@Michco.com](mailto:Shop@Michco.com)**  
By Fax: (517) 702-2041  
By Voice: Use numbers above.

**Serving the Cleaning Industry Since 1922**

Notice: All copyrighted material remains property of original owners, all trademarks are property of respective owners. Manuals are subject to Manufacturer's reproduction limitations. Originals or reproductions were provided by manufacturers through a request. We make no warranty as to the correctness of information provided in this document and you assume all risk.

# SW 850B / SW 850G

---

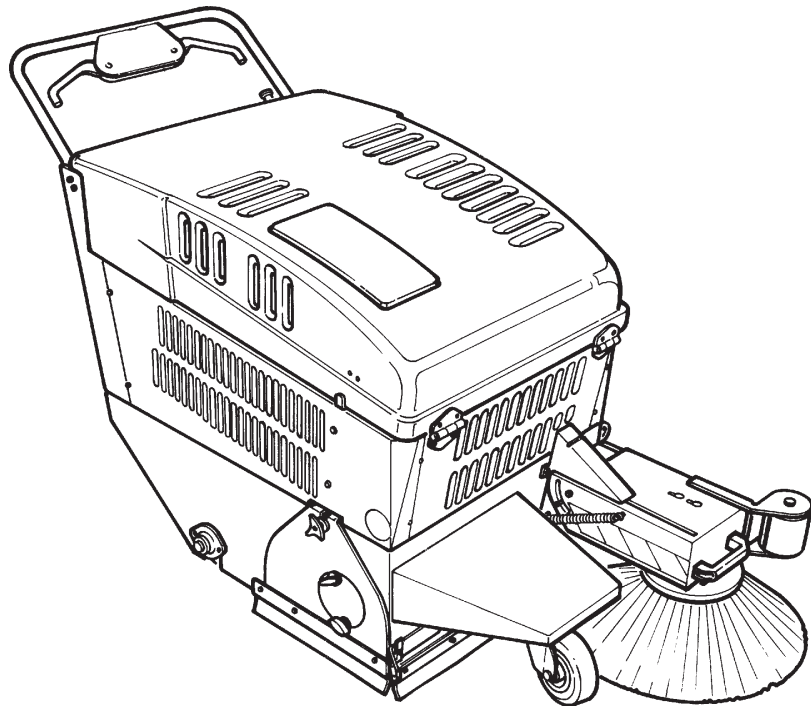

## PARTS LIST

Advance MODELS 908 2213 010, 908 3401 010

ACCESSORIO  
 OPTIONAL  
 ACCESSOIRES  
 ZUBEHÖR

VERSIONE A BENZINA  
 GASOLINE VERSION  
 BENZIN VERSION  
 MODELL ESSENCE

VERSIONE A BATTERIA  
 BATTERY VERSION  
 VERSION A BATTERIE  
 BATTERIE MODELL

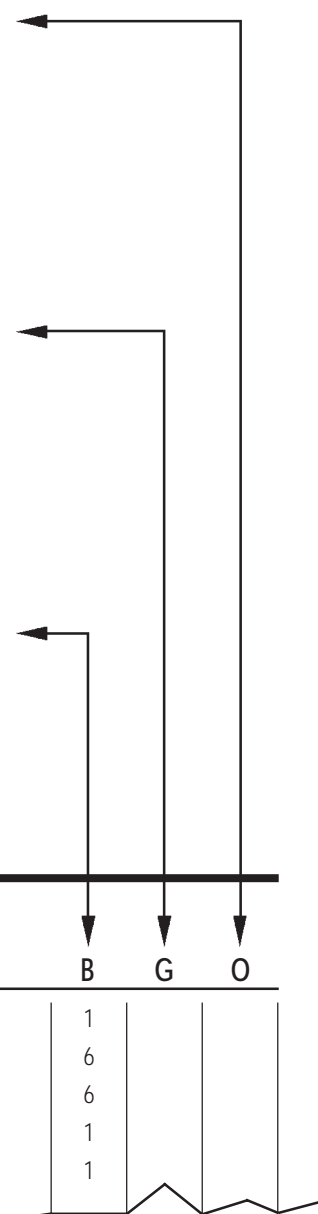

POSIZ. ITEM POS. EINSAT.	CODICE CODE CODE NUMMER	CODICE INTERNO INTERNAL CODE CODE INTERIEUR INTERNE NUMBER	DESCRIZIONE DESCRIPTION DESCRIPTION BEZEICHNUNG	B	G	O
5		F00.65600	PARAURTI / MOUNTING BRACKET / PARACHOCS / STOSSDAEMPFER	1		
6		V11.02200	RONDELLA / WASHER / RONDELLE / BEILAGSCHEIBE	6		
7		# V03.044	VITE / SCREW / VIS / SCHRAUBE	6		
8		H02.34670	TAPPETINO / MAT BOARD / TAPIS / TEPPICH	1		
9		F00.62200	PIANTONE / COLUMN / COLONNE / LENKROH	1		

# = New code numbers

### WHEN ORDERING PARTS

- \* Specify the model and serial number of the machine.
- \* Use the space below to record the model and serial number for future reference.

Model \_\_\_\_\_ Serial No. \_\_\_\_\_

# INDEX

Advance SW 850 B MODEL 908 2213 010 - Advance SW 850 G MODEL 908 3401 010

ELECTRIC DIAGRAM SW 850 B .....	Page 4
ELECTRIC DIAGRAM SW 850 G .....	Page 5
LIST OF RECOMMENDED SPARE PARTS .....	Page 6
CHASSIS ASSEMBLY .....	Page 7
SKIRT ASSEMBLIES .....	Page 9
DUST CONTROL FILTER .....	Page 11
MAIN BROOM ASSEMBLY .....	Page 13
SIDE BROOM ASSEMBLY .....	Page 15
IMPELLER/BATTERIES .....	Page 19
ENGINE ASSEMBLY .....	Page 23
CONTROL PANEL .....	Page 27
HOPPER .....	Page 29



**LEGENDA**

MSW	MICRO DI SICUREZZA / SECURITY MSW
M1	MOTORE TRAZIONE E ASPIRAZIONE / DRIVE END VACUUM MOTOR
M2	MOTORE SQUOTIFILTRO / FILTER SHAKER MOTOR
C1	CHIAVE / MAIN KEY SWITCH
C2	PULSANTE SQUOTIFILTRO / FILTER SHAKER SWITCH
C3	CONNESSIONE BATTERIA / BATTERY CONNECTOR
TL1	TELERUTTORE GENERALE / GENERAL SWITCH
RL1	RELE' SQUOTIFILTRO / FILTER SHAKER RELAY
SK1	SCHEDA DISPLAY / DISPLAY ELECTRIC BOARD

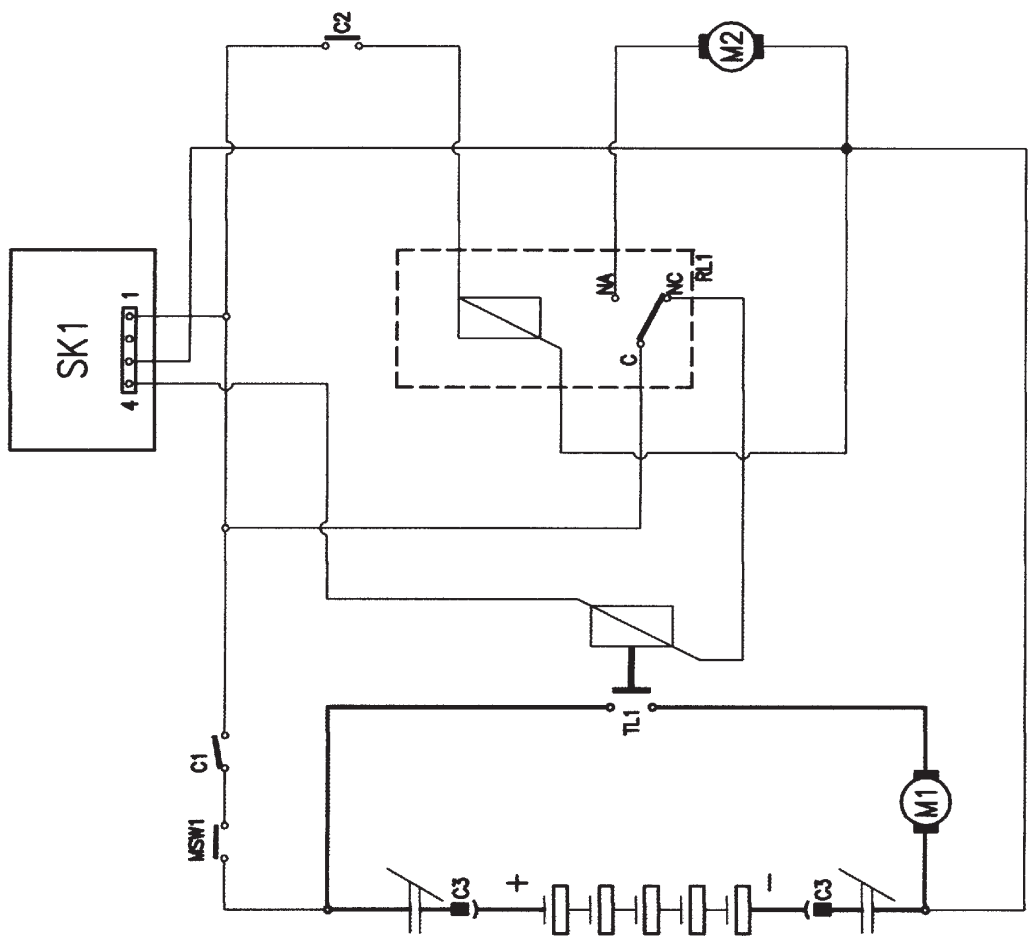

 Nilfisk Advance <small>INSTRUMENTAZIONE SPA S.p.A.</small> <small>via S. Felice - 37060 - VERONA - ITALIA</small>	Description SCHEMA ELETTRICO / ELECTRIC DIAGRAM SW 700 B & SW 850 B	CODICE 080/026.00 EE. CODE 145 4948 000	Revisions A - B - C - D - E -
	Date 02.04.98	Name CERRA	Checker CREMONESI

IL PRESENTE INDIRIZZO E' DI PROPRIETA' DELLA NILFISK-ADVANCE SPA CHE NE TIRERA' I DIRITTI MORALI A TERMINI DI LEGGE.  
 PREVIAMO NON POT' ESSERE RIPRODOTTO NE' COMMERCIATO A TITOLO SENZA PRESENTARE AUTORIZZAZIONE SCRITTA

LEGENDA	
MSW	MICRO DI SICUREZZA / SAFETY MSW
SP	CANDELA MOTORE / ENGINE SPARK PLUG
C1	CHIAVE / MAIN KEY SWITCH

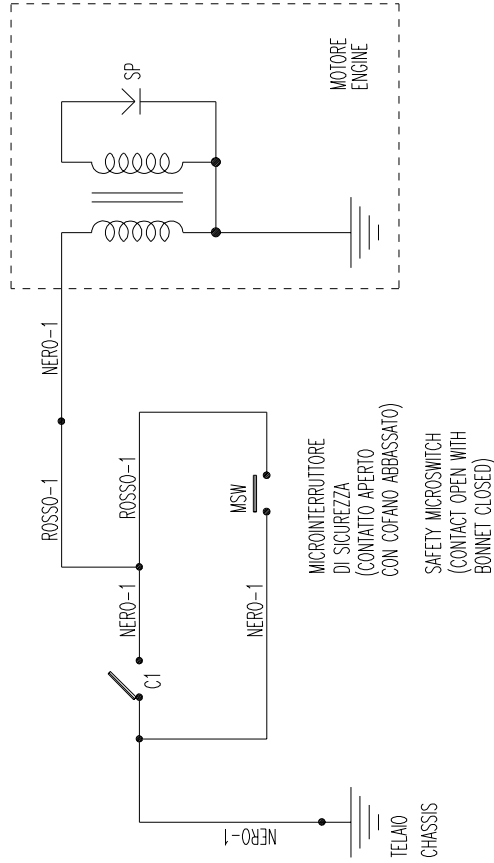

 Nilfisk Advance <small>NILFISK-ADVANCE ITALIA SPA            CARRARESE (LO)</small>	Description		Code Sparten/Parte		Revisions	
	SCHEMA ELETTRICO / ELECTRIC DIAGRAM SW 700 G & SW 850 G				A -	
<small>IL PRESENTE SCHEMA È DI PROPRIETÀ DELLA NILFISK-ADVANCE ITALIA SPA. NE' OGNI ALTRA COPIA DEVE ESSERE INDICATA LA FONTE. È vietata la ristampa o l'uso non autorizzato senza permesso scritto dalla Nilfisk-Advance Italia Spa.</small>		Date		B -		
		22.02.00		C -		
		Name		D -		
		CERRA		E -		
		Checker				
		ORSI				





# CHASSIS ASSEMBLY

POSIZ. ITEM POS. EINSAT.	CODICE CODE CODE NUMMER	CODICE INTERNO INTERNAL CODE CODE INTERIEUR INTERNE NUMMER	DESCRIZIONE DESCRIPTION DESCRIPTION BEZEICHUNG	Advance SW 850 B MODEL 908 2213 010 Advance SW 850 G MODEL 908 3401 010		
				B	G	O
1	145 4835 000	-	COFANO MOTORE / BONNET / CAPOTAGE / MOTORHAUBE (GREY 7001)	1		
1	#146 0002 00	-	COFANO MOTORE / BONNET / CAPOTAGE / MOTORHAUBE		1	
2	145 4816 000	-	TAPPO / CAP / BOUCHON / PFROPFEN	1	1	
4	145 4820 000	-	MICROINT. / MICROSWITCH / MICROINTERRUPTEUR / MICROSCHALTER	1	1	
5	145 0399 000	L02.16080	CERNIERA / HINGE / CHARNIERE / SCHARNIER	2	2	
6	145 6030 000	-	LEVA COFANO / LEVER / LEVIER / HEBEL SX	1	1	
7	# 145 6028 000	-	FIANCHETTO SX / SIDE FRAME / PANNEAU / WANGE	1	1	
8	# 145 6029 000	-	FIANCHETTO DX / SIDE FRAME / PANNEAU / WANGE	1	1	
9	145 6046 000	-	FRONTALE / FRONT PANEL / PANNEAU AV. / VORDER PANEL	1	1	
10	145 6044 000	-	SUPPORTO MANIGLIONE / HANDLE SUPPORT / SUPPORT POIGNE / HANDGRIFFHALTER	1	1	
11	145 6045 000	-	MANIGLIONE / HANDLE / POIGNE / HANDGRIFF	1	1	
12	145 4640 000	-	TERMINALE PARACOLPI / BUMPER END / EXTRÉMITÉ DE LA BARRE ANTI-CHOC / ENDE DES GUMMIPUFFERS	2	2	
13	145 4851 000	-	PROTEZIONE / GUARD / PROTECTION / SCHUTZ	1	1	
14	145 4291 000	M03.021	GUARNIZIONE / GASKET / JOINT / DICHTUNG	4	4	
15	145 9275 000	V14.009	SEEGER / RETAINING RING / CIRCLIPS / SICHERUNGSRING	2	2	
16	145 4842 000	-	TELAIO / FRAME / CHASSIS / RAHMEN	1	1	
17	145 5115 000	-	RUOTA / WHEEL / ROUE / RAD	1	1	
18	145 4828 000	-	ALBERO / SHAFT / ARBRE / WELLE	1	1	
19	145 4741 000	-	COPRI MOLLA / SPRING COVER / HOUSSE RESSORT / FEDERDECKUNG	2	2	
20	145 4739 000	-	MOLLA SX / SPRING / HOUSSE / FEDER	1	1	
21	145 4740 000	-	MOLLA DX / SPRING / HOUSSE / FEDER	1	1	
22	145 5324 000	-	RUOTA / WHEEL / ROUE / RAD	2	2	
23	145 8015 000	C04.01900	SUPPORTO / SUPPORT / SUPPORT / HALTER	2	2	
24	145 4738 000	-	PULEGGIA / PULLEY / POULIE / SCHEIBE	1	1	
25	145 5306 000	-	CINGHIA / BELT / COURROIE / RIEMEN	1	1	
26	145 6031 000	-	LEVA COFANO / LEVER / LEVIER / HEBEL DX	1	1	
28	145 4753 000	-	PIATTINA / PLATE / PLAQUE / BAND	1	1	
29	145 4801 000	-	CUSCINETTO / BALL BEARING / ROULEMENT / LAGER	2	2	
30	145 9115 000	V02.012	VITE / SCREW / VIS / SCHRAUBE	2	2	
31	145 9120 000	V09.005	RONDELLA / WASHER / RONDELLE / BEILAGSCHEIBE	2	2	
32	145 9170 000	V02.013	VITE / SCREW / VIS / SCHRAUBE	4	4	
33	145 9213 000	V09.020	RONDELLA / WASHER / RONDELLE / BEILAGSCHEIBE	4	4	
34	145 0569 000	V04.05090	VITE / SCREW / VIS / SCHRAUBE	4	4	
35	145 1163 000	V03.06200	VITE / SCREW / VIS / SCHRAUBE	2	2	
36	145 9287 000	V13.018	DADO / NUT / ECROU / MUTTER	4	4	
37	145 9286 000	V04.01500	VITE / SCREW / VIS / SCHRAUBE	4	4	
38	145 9132 000	V13.019	DADO / NUT / ECROU / MUTTER	4	4	
39	145 6034 000	-	TIRANTE / TENSION ROD / TIRANT / ZUGSTANGE	2	2	
40	145 6024 000	-	COPRIPERNO / PIN-CAP / COUVRE-PIVOT / BOLZENDECKEL	4	4	
41	145 6059 000	-	DECALCOMANIA / WARNING PLATE / PLAQUETTE / BESCHILDERUNG	1		

# SKIRT ASSEMBLIES

Advance SW 850 B MODEL 908 2213 010 - Advance SW 850 G MODEL 908 3401 010

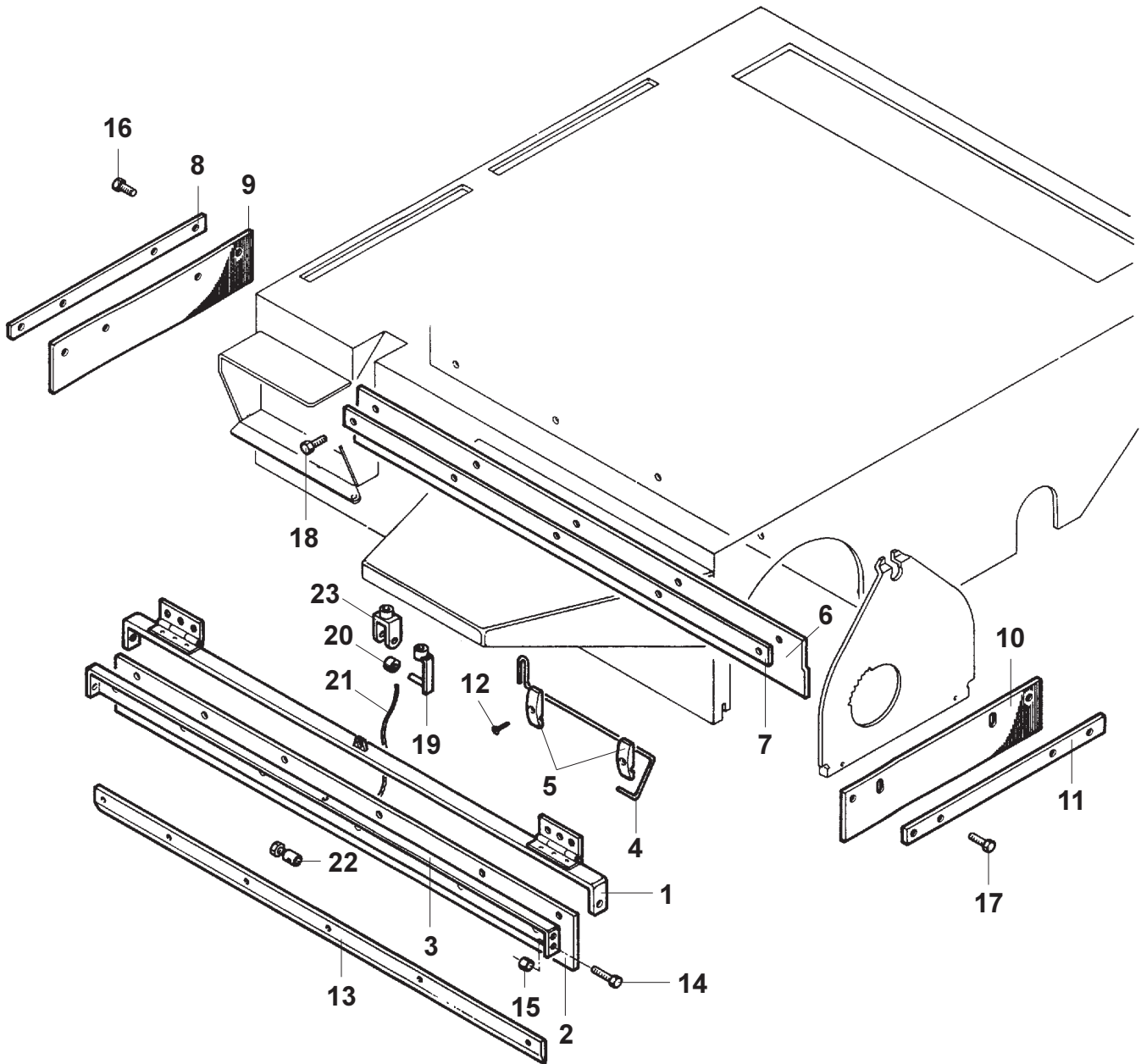

# SKIRT ASSEMBLIES

POSIZ. ITEM POS. EINSAT.	CODICE CODE CODE NUMMER	CODICE INTERNO INTERNAL CODE CODE INTERIEUR INTERNE NUMMER	DESCRIZIONE DESCRIPTION DESCRIPTION BEZEICHNUNG	Advance SW 850 B MODEL 908 2213 010 Advance SW 850 G MODEL 908 3401 010		
				B	G	O
1	145 4829 000	-	PORTA ALZAFLAP / SUPPORT / SUPPORT / HALTER	1	1	
2	145 4830 000	-	FLAP ANTERIORE / FRONT FLAP / BAVETTE ANT. / VORDER FLAP GUMMI	1	1	
3	145 4827 000	-	ALZAFLAP / SUPPORT / SUPPORT / HALTER	1	1	
4	145 4735 000	-	MOLLA / SPRING / HOUSSE / FEDER	2	2	
5	145 1180 000	H01.26340	PIATTINA / PLATE / PLAQUE / BAND	4	4	
6	145 4832 000	-	FLAP POSTERIORE / REAR FLAP / BAVETTE AR / HINTERE FLAP GUMMI	1	1	
7	145 4833 000	-	PIATTINA FLAP POST. / PLATE / PLAQUE / BAND	1	1	
8	145 4758 000	-	PIATTINA FLAP DX / PLATE / PLAQUE / BAND	1	1	
9	145 4762 000	-	FLAP / FLAP / BAVETTE / FLAP GUMMI DX	1	1	
10	145 5004 000	-	FLAP / FLAP / BAVETTE / FLAP GUMMI SX	1	1	
11	145 4759 000	-	PIATTINA FLAP SX / PLATE / PLAQUE / BAND	1	1	
12	145 9211 000	V05.001	VITE / SCREW / VIS / SCHRAUBE	4	4	
13	145 4831 000	-	PIATTINA FLAP ANT. / PLATE / PLAQUE / BAND	1	1	
14	145 9135 000	V02.023	VITE / SCREW / VIS / SCHRAUBE	2	2	
15	145 9287 000	V13.018	DADO / NUT / ECROU / MUTTER	2	2	
16	145 5063 000	V05.00603	VITE / SCREW / VIS / SCHRAUBE	4	4	
17	145 9261 000	V02.003	VITE / SCREW / VIS / SCHRAUBE	2	2	
18	145 5063 000	V05.00603	VITE / SCREW / VIS / SCHRAUBE	3	3	
19	145 9402 000	V17.06500	CLIPS / CLIPS / CLIPS / CLIPS	1	1	
20	145 1252 000	E05.19170	DISTANZIALE / SPACER / ENTRETOISE / ABSTANDSSTÜCK	1	1	
21	145 5071 000	-	CAVO / CABLE / CABLE / KABEL	1	1	
22	145 8110 000	E08.010	MORSETTO / CLAMP / SERRE CABLE / BÜGEL	2	2	
23	145 5186 000	-	FORCELLA / FORK / FOURCHETTE / GABEL	1	1	

# DUST CONTROL FILTER

Advance SW 850 B MODEL 908 2213 010 - Advance SW 850 G MODEL 908 3401 010

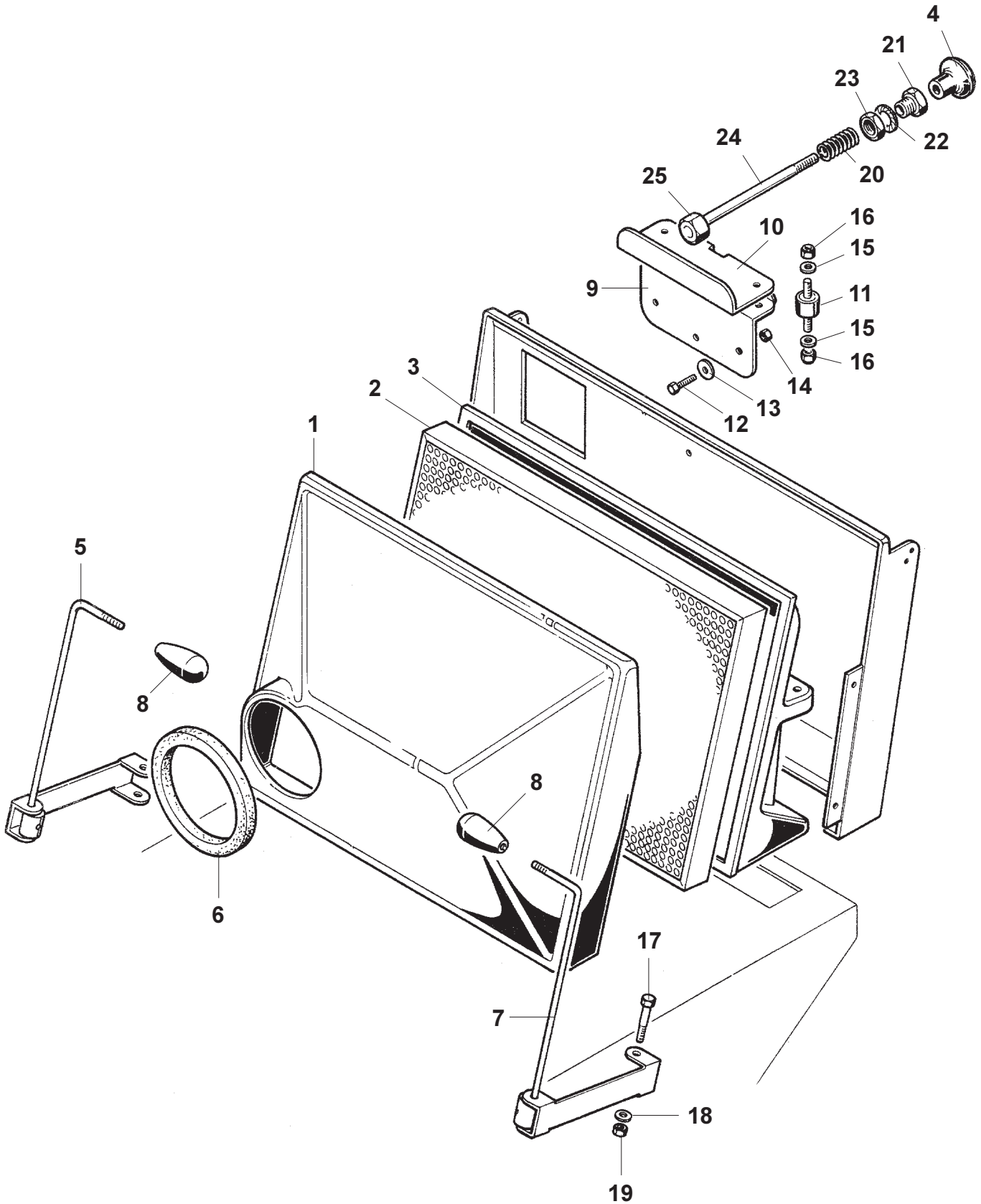

# DUST CONTROL FILTER

POSIZ. ITEM POS. EINSAT.	CODICE CODE CODE NUMMER	CODICE INTERNO INTERNAL CODE CODE INTERIEUR INTERNE NUMMER	DESCRIZIONE DESCRIPTION DESCRIPTION BEZEICHUNG	Advance SW 850 B MODEL 908 2213 010 Advance SW 850 G MODEL 908 3401 010		
				B	G	O
1	145 4643 000	-	COPERCHIO / LID COVER / COUVERCLE / DECKEL	1		
1	# 146 0121 00	-	COPERCHIO / LID COVER / COUVERCLE / DECKEL		1	
2	145 4806 000	-	FILTRO / FILTER / FILTRE / FILTER	1	1	
3	145 4644 000	-	PORTAFILTRO / FILTER HOLDER / PORTE FILTRE / FILTERHALTER	1		
3	# 146 0122 00	-	PORTAFILTRO / FILTER HOLDER / PORTE FILTRE / FILTERHALTER		1	
4	145 4802 000	-	POMELLO / KNOB / BOULE / KÜGELGRIFF	1	1	
5	145 1931 000	-	LEVA DX / LEVER / LEVIER / HEBEL	1	1	
6	145 5387 000	-	GUARNIZIONE / GASKET / JOINT / DICHTUNG	1	1	
7	145 1930 000	-	LEVA SX / LEVER / LEVIER / HEBEL	1	1	
8	145 9319 000	L03.02400	MANOPOLA / KNOB / POIGNEE / DREHKNOPF	2	2	
9	145 1933 000	-	PORTA SCUOTIFILTRO / FILTERSHAKER HOLDER / PORTE DECOLMATAGE DU FILTRE / FILTERRÜTLERHALTER	1	1	
10	145 1934 000	-	SCUOTIFILTRO / FILTERSHAKER / DECOLMATAGE DU FILTRE / FILTERRÜTLER	1	1	
11	145 8007 000	L02.15700	ANTIVIBRANTE / VIBRATION DAMPING / SILENT BLOC / SCHWINGUNGSDAMP.	2	2	
12	145 9261 000	V02.003	VITE / SCREW / VIS / SCHRAUBE	3	3	
13	145 9129 000	V09.012	RONDELLA / WASHER / RONDELLE / BEILAGSCHEIBE	3	3	
14	145 9132 000	V13.019	DADO / NUT / ECROU / MUTTER	3	3	
15	145 9233 000	V19.004	RONDELLA / WASHER / RONDELLE / BEILAGSCHEIBE	4	4	
16	145 9154 000	V13.004	DADO / NUT / ECROU / MUTTER	4	4	
17	145 0349 000	V02.008	VITE / SCREW / VIS / SCHRAUBE	2	2	
18	145 9128 000	V09.004	RONDELLA / WASHER / RONDELLE / BEILAGSCHEIBE	4	4	
19	145 9132 000	V13.019	DADO / NUT / ECROU / MUTTER	2	2	
20	145 1935 000	-	MOLLA / SPRING / HOUSSE / FEDER	1	1	
21	145 4928 000	-	GUIDA SCUOTIFILTRO / SLIDE / GUIDE / FÜHRUNGSBAHN	1	1	
22	145 4556 000	V19.006	RONDELLA / WASHER / RONDELLE / BEILAGSCHEIBE	1	1	
23	145 4515 000	V13.006	DADO / NUT / ECROU / MUTTER	1	1	
24	145 9623 000	V04.02703	VITE / SCREW / VIS / SCHRAUBE	1	1	
25	145 5020 000	-	DISTANZIALE / SPACER / ENTRETOISE / ABSTANDSSTÜCK	1	1	

# MAIN BROOM ASSEMBLY

Advance SW 850 B MODEL 908 2213 010 - Advance SW 850 G MODEL 908 3401 010

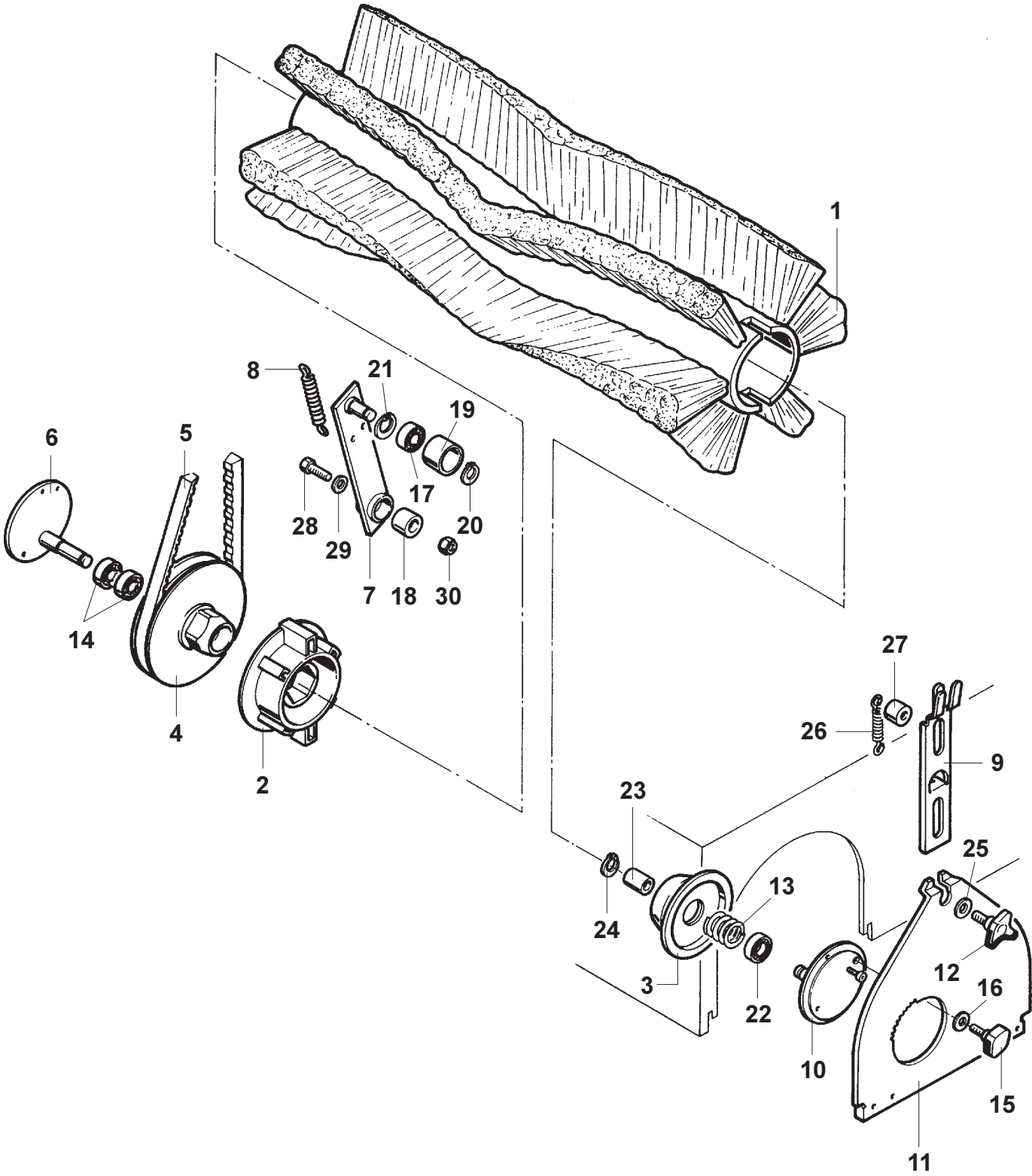

# MAIN BROOM ASSEMBLY

POSIZ. ITEM POS. EINSAT.	CODICE CODE CODE NUMMER	CODICE INTERNO INTERNAL CODE CODE INTERIEUR INTERNE NUMMER	DESCRIZIONE DESCRIPTION DESCRIPTION BEZEICHNUNG	Advance SW 850 B MODEL 908 2213 010 Advance SW 850 G MODEL 908 3401 010		
				B	G	O
1	145 4845 000	-	SPAZZOLA / BRUSH / BROSSE / BÜRSTE	1	1	
1	145 4983 000	-	SPAZZOLA CENTRALE MISTA ACCIAIO / CENTRAL BRUSH OF MIXED STEEL MATERIAL / BROSSE CENTRALE MIXTE EN ACIER / ZENTRALBÜRSTE AUS GEMISCHTEM STAHLMATERIAL			1
1	145 4981 000	-	SPAZZOLA CENTRALE SAGGINA / BROOMCORN CENTRAL BRUSH / BROSSE CENTRALE EN SORGHO / ZENTRALBÜRSTE AUS BESENMOHRHIRSE			1
2	145 5661 000	-	MOZZO / HUB / MOYEU / NABE (DX)	1	1	
3	145 0269 000	E02.68870	MOZZO / HUB / MOYEU / NABE (SX)	1	1	
4	145 2617 000	E03.18320	PULEGGIA / PULLEY / POULIE / SCHEIBE	1	1	
5	145 8199 000	H00.11700	CINGHIA / BELT / COURROIE / RIEMEN	1	1	
6	145 0272 000	E02.68860	PERNO / PIN / AXE / STIFT	1	1	
7	145 1210 000	F03.69270	LEVA / LEVER / LEVIER / HEBEL	1	1	
8	145 0274 000	E04.09490	MOLLA / SPRING / HOUSSE / FEDER	1	1	
9	145 1939 000	-	PIASTRINA / PLATE / PLAQUE / PLATTE	1	1	
10	145 0272 000	E02.68860	PERNO / PIN / AXE / STIFT	1	1	
11	145 1918 000	-	PORTELLO / HATCH / REGARD / Klappe	1	1	
12	145 2247 000	L02.16060	VOLANTINO / KNOB / MOLETTE / HANDRAD	1	1	
13	145 0271 000	E04.09460	MOLLA / SPRING / HOUSSE / FEDER	1	1	
14	145 0270 000	E00.023	CUSCINETTO / BALL BEARING / ROULEMENT / LAGER	2	2	
15	145 1211 000	L02.16050	VOLANTINO / KNOB / MOLETTE / HANDRAD	2	2	
16	145 9229 000	V09.022	RONDELLA / WASHER / RONDELLE / BEILAGSCHEIBE	2	2	
17	145 9186 000	E00.007	CUSCINETTO / BALL BEARING / ROULEMENT / LAGER	1	1	
18	145 9405 000	E01.007	BUSSOLA / BUSH / BAGUE / BUCHSE	1	1	
19	145 1209 000	E02.68910	RULLO / ROLLER / ROULEAU / ROLLE	1	1	
20	145 9259 000	V14.007	SEEGER / RETAINING RING / CIRCLIPS / SICHERUNGSRING	1	1	
21	145 9189 000	V14.013	SEEGER / RETAINING RING / CIRCLIPS / SICHERUNGSRING	1	1	
22	145 0270 000	E00.023	CUSCINETTO / BALL BEARING / ROULEMENT / LAGER	1	1	
23	145 2663 000	E05.12100	DISTANZIALE / SPACER / ENTRETOISE / ABSTANDSSTÜCK	1	1	
24	145 9187 000	V14.006	SEEGER / RETAINING RING / CIRCLIPS / SICHERUNGSRING	1	1	
25	145 9120 000	V09.005	RONDELLA / WASHER / RONDELLE / BEILAGSCHEIBE	1	1	
26	145 9290 000	E04.05200	MOLLA / SPRING / HOUSSE / FEDER	1	1	
27	145 1252 000	E05.19170	DISTANZIALE / SPACER / ENTRETOISE / ABSTANDSSTÜCK	2	2	
28	145 9170 000	V02.013	VITE / SCREW / VIS / SCHRAUBE	1	1	
29	145 9120 000	V09.005	RONDELLA / WASHER / RONDELLE / BEILAGSCHEIBE	1	1	
30	145 9123 000	V13.005	DADO / NUT / ECROU / MUTTER	1	1	

# SIDE BROOM ASSEMBLY

Advance SW 850 B MODEL 908 2213 010 - Advance SW 850 G MODEL 908 3401 010

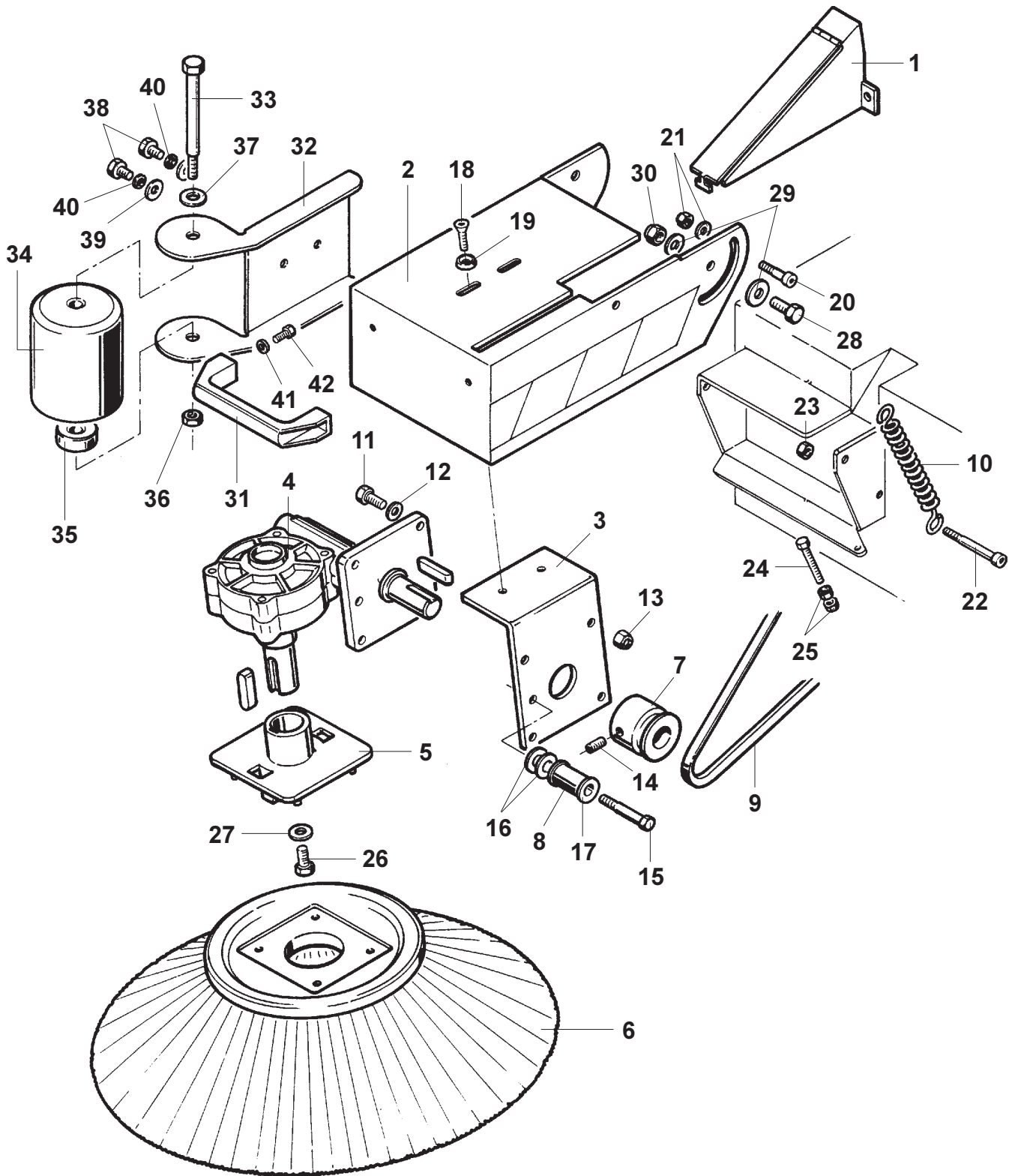

# SIDE BROOM ASSEMBLY

POSIZ. ITEM POS. EINSAT.	CODICE CODE CODE NUMMER	CODICE INTERNO INTERNAL CODE CODE INTERIEUR INTERNE NUMMER	DESCRIZIONE DESCRIPTION DESCRIPTION BEZEICHUNG	Advance SW 850 B MODEL 908 2213 010 Advance SW 850 G MODEL 908 3401 010		
				B	G	O
1	145 4748 000	-	PROTEZIONE / GUARD / PROTECTION / SCHUTZ	1	1	
2	145 6043 000	-	SUPPORTO / SUPPORT / SUPPORT / HALTER	1	1	
3	145 4750 000	-	STAFFA / HANGER / ETRIER / BÜGEL	1	1	
4	145 2324 000	C00.01502	RIDUTTORE / REDUCTION GEAR / RED. / VERMINDERUNGSGETRIEBE	1	1	
5	145 4812 000	-	FLANGIA / FLANGE / FLASQUE / FLANSCH	1	1	
6	145 1899 000	-	SPAZZOLA / BRUSH / BROSSE / BÜRSTE	1	1	
6	145 4976 000	-	SPAZZOLA LATERALE SAGGINA / BROOMCORN SIDE BRUSH / BROSSE LATERALE EN SORGHO/ SEITENBÜRSTE AUS BESENMOHRHIRSE			1
6	145 4959 000	-	SPAZZOLA LATERALE MISTA ACCIAIO / SIDE BRUSH OF MIXED STEEL MATERIAL / BROSSE LATERALE MIXTE EN ACIER / SEITENBÜRSTE AUS GEMISCHTEM STAHLMATERIAL			1
7	145 5470 000	-	PULEGGIA / PULLEY / POULIE / SCHEIBE	1	1	
8	145 1751 000	E05.19280	DISTANZIALE / SPACER / ENTRETOISE / ABSTANDSSTÜCK	1	1	
9	145 3848 000	H00.039	CINGHIA / BELT / COURROIE / RIEMEN	1	1	
10	145 4800 000	-	MOLLA / SPRING / HOUSSE / FEDER	1	1	
11	145 9141 000	V02.06700	VITE / SCREW / VIS / SCHRAUBE	4	4	
12	145 9237 000	V09.04200	RONDELLA / WASHER / RONDELLE / BEILAGSCHEIBE	4	4	
13	145 9125 000	V13.06100	DADO / NUT / ECROU / MUTTER	4	4	
14	145 4499 000	V08.00400	GRANO / DOWEL / GOUPILLE / STIFT	1	1	
15	145 1194 000	V02.005	VITE / SCREW / VIS / SCHRAUBE	1	1	
16	145 9128 000	V09.004	RONDELLA / WASHER / RONDELLE / BEILAGSCHEIBE	2	2	
17	145 1752 000	E05.19290	DISTANZIALE / SPACER / ENTRETOISE / ABSTANDSSTÜCK	2	2	
18	145 4488 000	V03.004	VITE / SCREW / VIS / SCHRAUBE	2	2	
19	145 9308 000	V11.02200	RONDELLA / WASHER / RONDELLE / BEILAGSCHEIBE	2	2	
20	145 0569 000	V04.05090	VITE / SCREW / VIS / SCHRAUBE	1	1	
21	145 9134 000	V13.003	DADO / NUT / ECROU / MUTTER	2	2	
22	145 0569 000	V04.05090	VITE / SCREW / VIS / SCHRAUBE	1	1	
23	145 9134 000	V13.003	DADO / NUT / ECROU / MUTTER	1	1	
24	145 9227 000	V02.004	VITE / SCREW / VIS / SCHRAUBE	1	1	
25	145 9154 000	V13.004	DADO / NUT / ECROU / MUTTER	1	1	
26	145 9261 000	V02.003	VITE / SCREW / VIS / SCHRAUBE	1	1	
27	145 9128 000	V09.004	RONDELLA / WASHER / RONDELLE / BEILAGSCHEIBE	1	1	
28	145 8005 000	V02.020	VITE / SCREW / VIS / SCHRAUBE	2	2	
29	145 9320 000	V09.006	RONDELLA / WASHER / RONDELLE / BEILAGSCHEIBE	4	4	
30	145 4515 000	V13.006	DADO / NUT / ECROU / MUTTER	2	2	
31	145 8461 000	L02.14000	MANIGLIA / HANDLE / POIGNEE / HANDGRIFF	1	1	
32	145 6033 000	-	STAFFA SUPPORTO RULLO / ROLLER SUPPORT HANGER / ETRIER SUPPORT ROULEAU / ROLLENTRAGBÜGEL	1	1	
33	145 6008 000	-	VITE / SCREW / VIS / SCHRAUBE	1	1	
34	145 6032 000	-	RULLO / ROLLER / ROULEAU / ROLLE	1	1	
35	145 6036 000	-	DISTANZIALE / SPACER / ENTRETOISE / ABSTANDSSTÜCK	1	1	
36	145 9167 000	V13.022	DADO / NUT / ECROU / MUTTER	1	1	
37	145 9165 000	V09.007	RONDELLA / WASHER / RONDELLE / BEILAGSCHEIBE	1	1	
38	145 9261 000	V02.003	VITE / SCREW / VIS / SCHRAUBE	2	2	
39	145 9128 000	V09.004	RONDELLA STAFFA SUPPORTO RULLO / ROLLER SUPPORT HANGER WASHER / RONDELLE ETRIER SUPPORT ROULEAU / UNTERLEGSCHIEBE ROLLENTRAGBÜGEL	2	2	
40	145 9228 000	V11.004	ROSETTA ELASTICA STAFFA SUPPORTO RULLO / ROLLER SUPPORT HANGER ELASTIC WASHER / RONDELLE ELASTIQUE ETRIER SUPPORT ROULEAU / FEDERSCHIEBE ROLLENTRAGBÜGEL	2	2	

# SIDE BROOM ASSEMBLY

Advance SW 850 B MODEL 908 2213 010 - Advance SW 850 G MODEL 908 3401 010

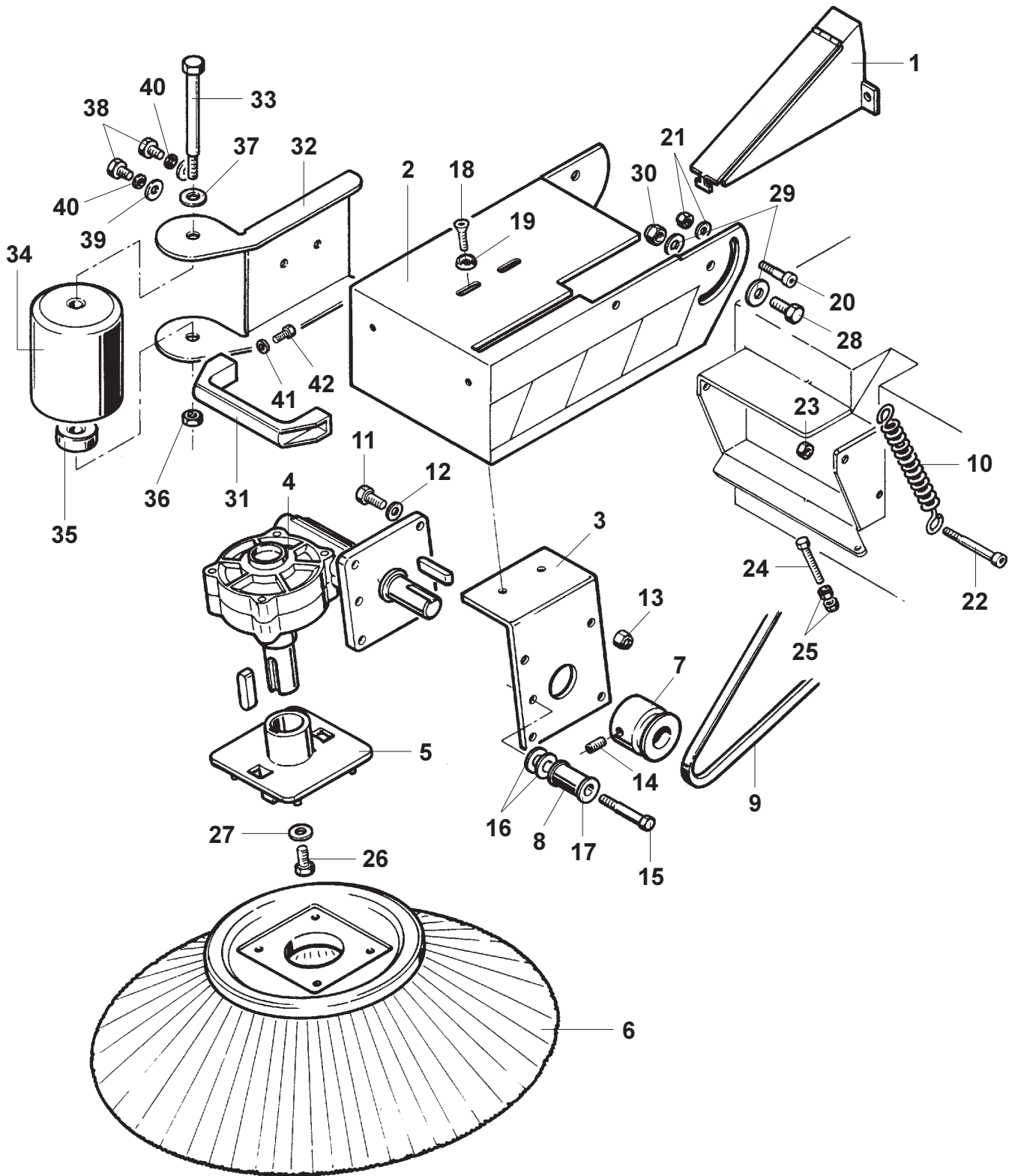

# SIDE BROOM ASSEMBLY

POSIZ. ITEM POS. EINSAT.	CODICE CODE CODE NUMMER	CODICE INTERNO INTERNAL CODE CODE INTERIEUR INTERNE NUMMER	DESCRIZIONE DESCRIPTION DESCRIPTION BEZEICHNUNG	Advance SW 850 B MODEL 908 2213 010 Advance SW 850 G MODEL 908 3401 010		
				B	G	O
41	145 9227 000	V02.004	RONDELLA / WASHER / RONDELLE / BEILAGSCHEIBE	2	2	
42	145 9128 000	V09.004	VITE / SCREW / VIS / SCHRAUBE	2	2	

# IMPELLER/BATTERIES

Advance SW 850 B MODEL 908 2213 010

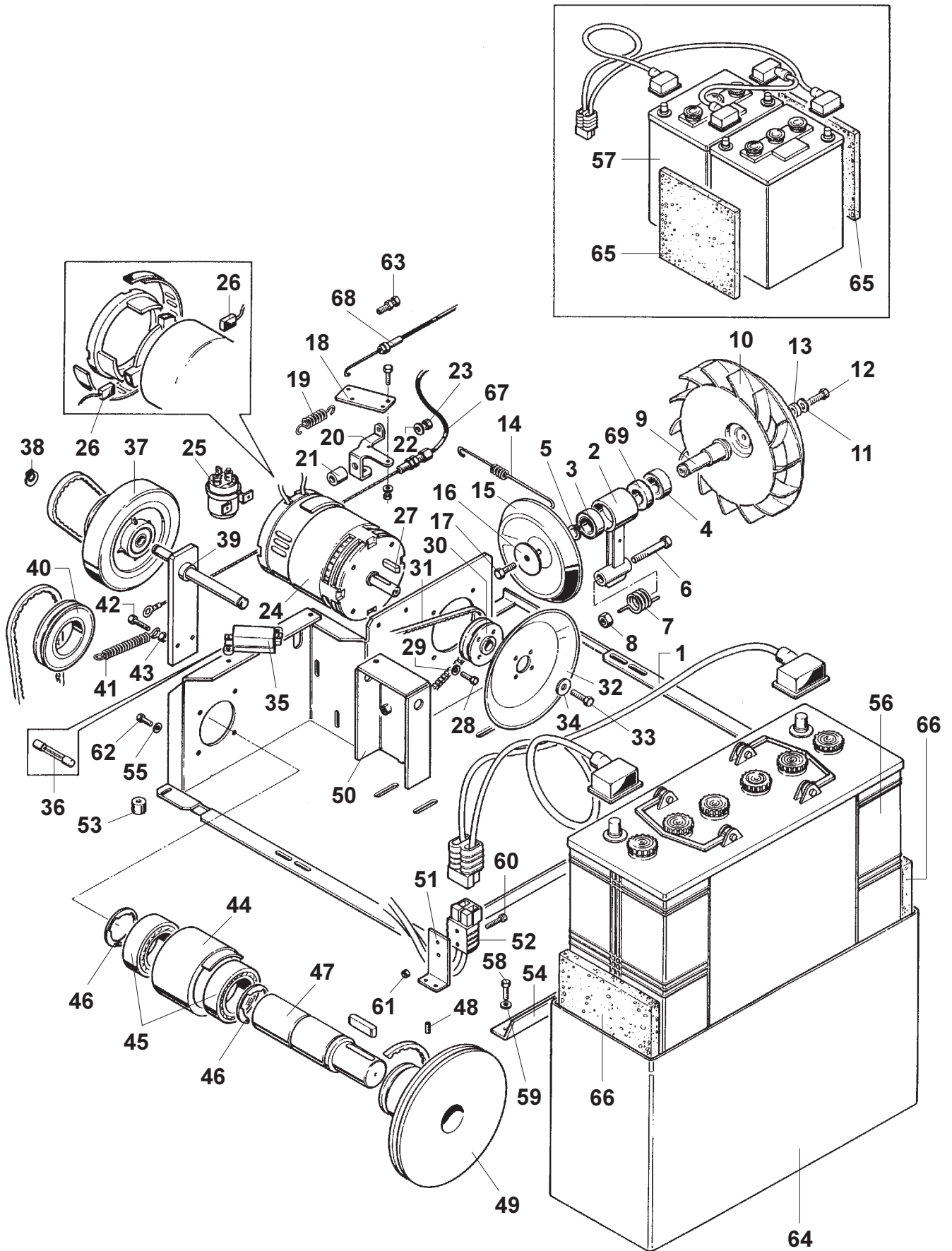

# IMPELLER/BATTERIES

POSIZ. ITEM POS. EINSAT.	CODICE CODE CODE NUMMER	CODICE INTERNO INTERNAL CODE CODE INTERIEUR INTERNE NUMMER	DESCRIZIONE DESCRIPTION DESCRIPTION BEZEICHNUNG	Advance SW 850 B MODEL 908 2213 010		
				B	G	O
1	145 1919 000	-	PIASTRA / PLATE / PLAQUE / PLATTE	1		
2	145 1922 000	-	SUPPORTO / SUPPORT / SUPPORT / HALTER	1		
3	145 9271 000	E00.030	CUSCINETTO / BALL BEARING / ROULEMENT / LAGER	1		
4	145 8415 000	E00.008	CUSCINETTO / BALL BEARING / ROULEMENT / LAGER	1		
5	145 9191 000	V14.008	SEEGER / RETAINING RING / CIRCLIPS / SICHERUNGSRING	1		
6	145 4729 000	-	VITE / SCREW / VIS / SCHRAUBE	1		
7	145 6086 000	-	MOLLA / SPRING / RESSORT / FEDER	1		
8	145 4518 000	V13.021	DADO / NUT / ECROU / MUTTER	1		
9	145 4726 000	-	ALBERO / SHAFT / ARBRE / WELLE	1		
10	145 9179 000	B03.001	VENTOLA / FAN / VENT / FLÜGEL	1		
11	145 9126 000	V19.005	RONDELLA / WASHER / RONDELLE / BEILAGSCHEIBE	1		
12	145 9115 000	V02.012	VITE / SCREW / VIS / SCHRAUBE	1		
13	145 9180 000	E05.027	DISTANZIALE / SPACER / ENTRETOISE / ABSTANDSSTÜCK	1		
14	145 5881 000	-	TIRANTE / TENSION ROD / TIRANT / ZUGSTANGE	1		
15	145 4728 000	-	RUOTA / WHEEL / ROUE / RAD	1		
16	145 9120 000	V09.005	RONDELLA / WASHER / RONDELLE / BEILAGSCHEIBE	1		
17	145 9115 000	V02.012	VITE / SCREW / VIS / SCHRAUBE	1		
18	145 5879 000	-	PIATTINA FLAP ANT. / PLATE / PLAQUE / BAND	1		
19	145 5545 000	-	MOLLA / SPRING / RESSORT / FEDER	1		
20	145 5880 000	-	STAFFA / HANGER / ETRIER / BÜGEL	1		
21	145 8054 000	L02.07900	ANTIVIBRANTE / VIBRATION DAMPING / SILENT BLOC / SCHWINGUNGSDÄMPFER	1		
22	145 9120 000	V09.005	RONDELLA / WASHER / RONDELLE / BEILAGSCHEIBE	2		
23	145 9123 000	V13.005	DADO / NUT / ECROU / MUTTER	2		
24	145 4798 000	-	MOTORE ELETTRICO / ELECTRIC MOTOR / MOTEUR ELECTR. / ELEKTROMOTOR	1		
25	145 9434 000	G02.004	TELERUTTORE / ELECTROMAGN. SWITCH / TELERUPTEUR / SCHALTER	1		
26	145 5042 000	-	SPAZZOLA / BRUSH / BROSE / BÜRSTE	4		
27	145 9774 000	V17.041	CHIAVETTA / KEY / CLAVETTE / KEILNUT	1		
28	145 9261 000	V02.003	VITE / SCREW / VIS / SCHRAUBE	4		
29	145 9233 000	V19.004	RONDELLA / WASHER / RONDELLE / BEILAGSCHEIBE	4		
30	145 5473 000	-	PULEGGIA / PULLEY / POULIE / SCHEIBE	1		
31	145 9701 000	H00.028	CINGHIA / BELT / COURROIE / RIEMEN	1		
32	145 4724 000	-	DISCO / PAD / DISQUE / DISK	1		
33	145 9261 000	V02.003	VITE / SCREW / VIS / SCHRAUBE	1		
34	145 9229 000	V09.022	RONDELLA / WASHER / RONDELLE / BEILAGSCHEIBE	1		
35	145 8046 000	G11.05000	PORTAFUSIBILE / FUSE HOLDER / PORTEFUSIBLE / SICHERUNGSTRÄGER	1		
36	145 8047 000	G11.04500	FUSIBILE / FUSE / FUSIBLE / SICHERUNG	1		
37	145 6037 000	-	RUOTA / WHEEL / ROUE / RAD	1		
38	145 4794 000	-	SEEGER / RETAINING RING / CIRCLIPS / SICHERUNGSRING	1		
39	145 4730 000	-	LEVA / LEVER / LEVIER / HEBEL	1		
40	145 4721 000	-	PULEGGIA / PULLEY / POULIE / SCHEIBE	1		
41	145 0274 000	E04.09490	MOLLA / SPRING / RESSORT / FEDER	1		
42	145 9261 000	V02.003	VITE / SCREW / VIS / SCHRAUBE	1		
43	145 9132 000	V13.019	DADO / NUT / ECROU / MUTTER	1		
44	145 4723 000	-	PORTACUSCINETTO / BALL BEARING HOLDER / ROULEMENT RACCORD / LAGERHALTER	1		
45	145 4795 000	-	CUSCINETTO / BALL BEARING / ROULEMENT / LAGER	2		
46	145 4796 000	-	SEEGER / RETAINING RING / CIRCLIPS / SICHERUNGSRING	2		

# IMPELLER/BATTERIES

Advance SW 850 B MODEL 908 2213 010

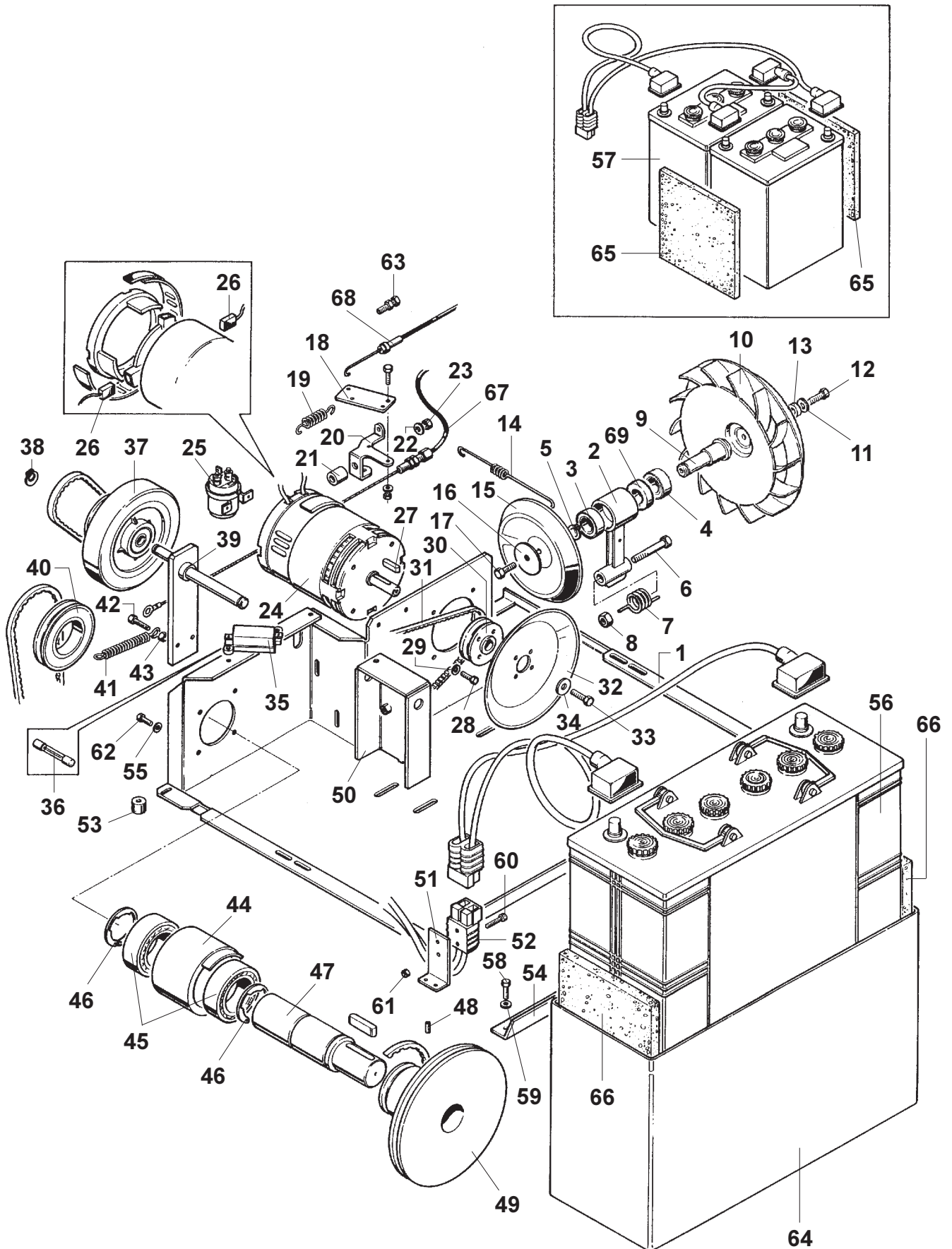

# IMPELLER/BATTERIES

POSIZ. ITEM POS. EINSAT.	CODICE CODE CODICE NUMMER	CODICE INTERNO INTERNAL CODE CODE INTERIEUR INTERNE NUMMER	DESCRIZIONE DESCRIPTION DESCRIPTION BEZEICHNUNG	Advance SW 850 B MODEL 908 2213 010		
				B	G	O
47	145 4720 000	-	ALBERO / SHAFT / ARBRE / WELLE	1		
48	145 4499 000	V08.00400	VITE / SCREW / VIS / SCHRAUBE	2		
49	145 5472 000	-	PULEGGIA / PULLEY / POULIE / SCHEIBE	1		
50	145 1920 000	-	STAFFA / HANGER / ETRIER / BÜGEL	1		
51	145 4755 000	-	STAFFA / HANGER / ETRIER / BÜGEL	1		
52	145 9417 000	G03.006	CONNETTORE / CONNECTOR / PRISE / KOPPLUNGSSTÜK	1		
53	145 8054 000	L02.07900	ANTIVIBRANTE / VIBRATION DAMPING / SILENT BLOC / SCHWINGUNGSDÄMPFER	3		
54	145 1923 000	-	STAFFA / HANGER / ETRIER / BÜGEL	1		
55	145 9233 000	V19.004	RONDELLA / WASHER / RONDELLE / BEILAGSCHEIBE	4		
56	145 0116 000	WOP.G3700	BATTERIA / BATTERY / BATTERIE / BATTERIE 12V / 140 Ah			1
57	145 0000 000	WOP.G0300	BATTERIA / BATTERY / BATTERIE / BATTERIE 6V / 240 Ah			2
58	145 9261 000	V02.003	VITE / SCREW / VIS / SCHRAUBE	2		
59	145 9128 000	V09.004	RONDELLA / WASHER / RONDELLE / BEILAGSCHEIBE	4		
60	145 4483 000	V02.09203	VITE / SCREW / VIS / SCHRAUBE	2		
61	145 9287 000	V13.018	DADO / NUT / ECROU / MUTTER	2		
62	145 9261 000	V02.003	VITE / SCREW / VIS / SCHRAUBE	4		
63	145 1179 000	E08.06800	REGISTRO M6 x 30 / ADJUSTMENT SCREZ M6 x 30 / VIS DE REGULATION M6 x 30 / EINSTELLSCHRAUBE M6 x 30	1		
64	145 5252 000	-	CONTENITORE BATTERIE IN PLASTICA / PLASTIC BATTERY BOX / RECIPIENT EN PLASTIQUE POUR BATTERIES / BATTERIEKASTEN AUS KUNSTSTOFF	1		
65	145 6094 000	-	PANNELLO-RESTRRAIN / PANEL-RESTRRAIN / PANNEAU-RESTRRAIN / PANEL-RESTRRAIN	2		
66	145 6095 000	-	PANNELLO-RESTRRAIN / PANEL-RESTRRAIN / PANNEAU-RESTRRAIN / PANEL-RESTRRAIN	2		
67	145 5310 000	-	CAVO TRAZIONE / CABLE / CABLE / KABEL	1		
68	145 1280 000	-	CAVO ASPIRAZIONE / CABLE / CABLE / KABEL	1		
69	-	E05.041	DISTANZIALE / SPACER / ENTRETOISE / ABSTANDSSTÜCK	1		

# ENGINE ASSEMBLY

Advance SW 850 G MODEL 908 3401 010

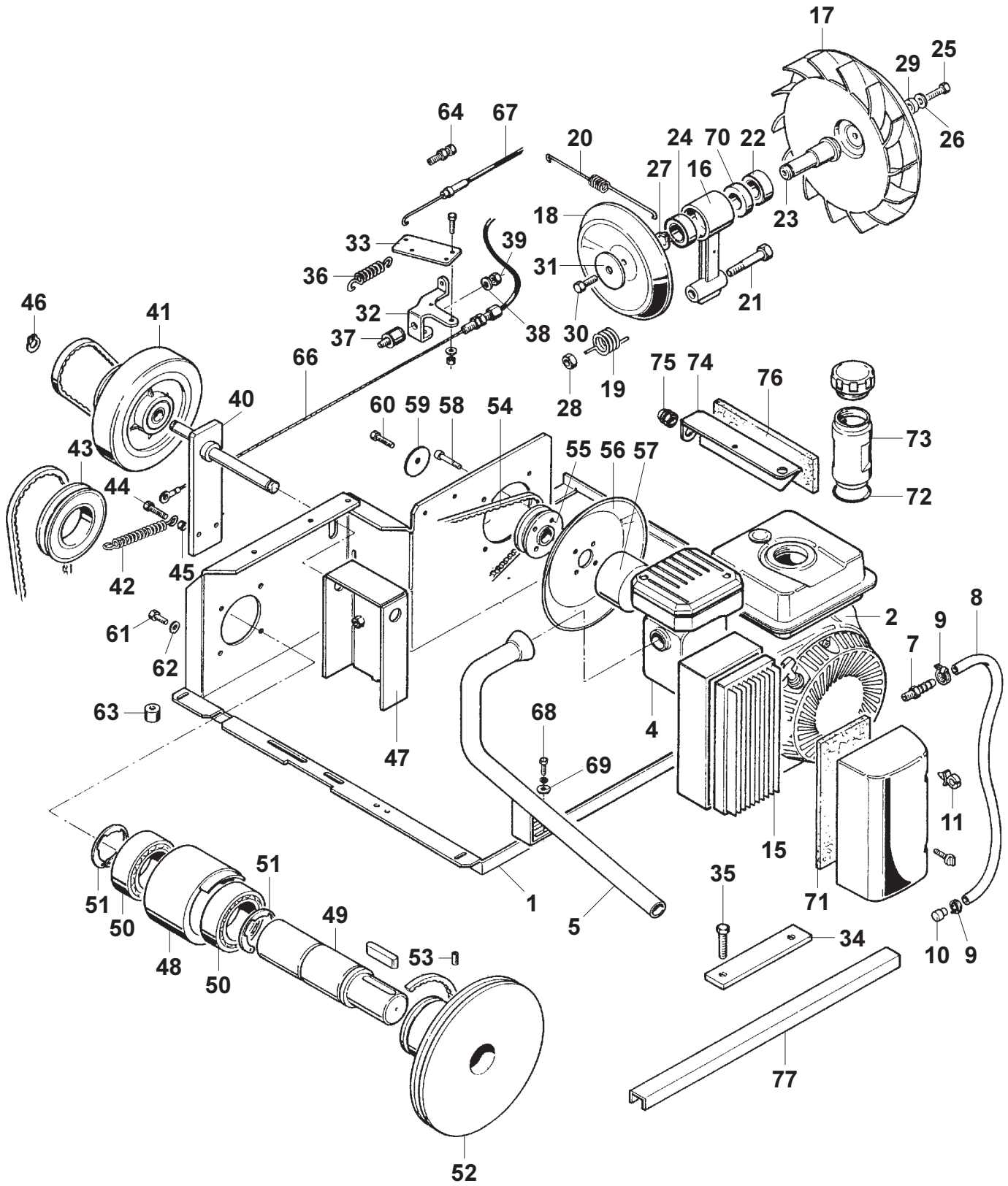

# ENGINE ASSEMBLY

POSIZ. ITEM POS. EINSAT.	CODICE CODE CODE NUMMER	CODICE INTERNO INTERNAL CODE CODE INTERIEUR INTERNE NUMMER	DESCRIZIONE DESCRIPTION DESCRIPTION BEZEICHNUNG	Advance SW 850 G MODEL 908 3401 010		
				B	G	O
1	145 1919 000	-	PIASTRA / PLATE / PLAQUE / PLATTE		1	
2	145 6113 000	-	MOTORE / MOTOR / MOTEUR / MOTOR		1	
4	145 6119 000	-	MARMITTA / SILENCER / MARMITE / SCHALLDAMPFER		1	
5	146 0007 00	-	TUBO / TUBE / TUYAU / SCHLAUCH		1	
7	145 6138 000	-	PORTAGOMMA / PIPE HOLDER / RACCORD / LEISTUNG HALTER		1	
8	145 5037 000	-	TUBO / TUBE / TUYAU / LEITUNGSSCHLAUCH		1	
9	145 8582 000	V20.02200	FASCETTA / CLAMP / COLLIER / PASSRING		2	
10	145 9220 000	M03.003	TAPPO / CAP / BOUCHON / PFROPFEN		1	
11	145 1281 000	V20.04400	FASCETTA / CLAMP / COLLIER / PASSRING		1	
15	145 6116 000	-	FILTRO ARIA / FILTER / FILTRE / FILTER		1	
16	145 1922 000	-	SUPPORTO / SUPPORT / SUPPORT / HALTER		1	
17	145 9179 000	B03.001	VENTOLA / FAN / VENT / FLÜGEL		1	
18	145 4728 000	-	RUOTA / WHEEL / ROUE / RAD		1	
19	145 6086 000	-	MOLLA / SPRING / HOUSSE / FEDER		1	
20	145 5881 000	-	TIRANTE / TENSION ROD / TIRANT / ZUGSTANGE		1	
21	145 4729 000	-	VITE / SCREW / VIS / SCHRAUBE		1	
22	145 8415 000	E00.008	CUSCINETTO / BALL BEARING / ROULEMENT / LAGER		1	
23	145 4726 000	-	ALBERO / SHAFT / ARBRE / WELLE		1	
24	145 9271 000	E00.030	CUSCINETTO / BALL BEARING / ROULEMENT / LAGER		1	
25	145 9115 000	V02.012	VITE / SCREW / VIS / SCHRAUBE		1	
26	145 9126 000	V19.005	RONDELLA / WASHER / RONDELLE / BEILAGSCHEIBE		1	
27	145 9191 000	V14.008	SEGER / RETAINING RING / CIRCLIPS / SICHERUNGSRING		1	
28	145 4518 000	V13.021	DADO / NUT / ECROU / MUTTER		1	
29	145 9180 000	E05.027	DISTANZIALE / SPACER / ENTRETOISE / ABSTANDSSTÜCK		1	
30	145 9115 000	V02.012	VITE / SCREW / VIS / SCHRAUBE		1	
31	145 9120 000	V09.005	RONDELLA / WASHER / RONDELLE / BEILAGSCHEIBE		1	
32	145 5880 000	-	STAFFA / HANGER / ETRIER / BÜGEL		1	
33	145 5879 000	-	PIATTINA FLAP ANT. / PLATE / PLAQUE / BAND		1	
34	145 1293 000	F03.68200	PIATTINA FLAP ANT. / PLATE / PLAQUE / BAND		2	
35	145 9217 000	V02.051	VITE / SCREW / VIS / SCHRAUBE		4	
36	145 5545 000	-	MOLLA / SPRING / HOUSSE / FEDER		1	
37	145 8054 000	L02.07900	ANTIVIBRANTE / VIBRATION DAMPING / SILENT BLOC / SCHWINGUNGSDÄMPFER		1	
38	145 9120 000	V09.005	RONDELLA / WASHER / RONDELLE / BEILAGSCHEIBE		2	
39	145 9123 000	V13.005	DADO / NUT / ECROU / MUTTER		2	
40	145 4730 000	-	LEVA / LEVER / LEVIER / HEBEL		1	
41	145 6037 000	-	RUOTA FRIZIONE / FRICTION WHEEL / ROUE DE FRICT. / KUPPLUNGSRAD		1	
42	145 0274 000	E04.09490	MOLLA / SPRING / HOUSSE / FEDER		1	
43	145 4721 000	-	PULEGGIA / PULLEY / POULIE / SCHEIBE		1	
44	145 9261 000	V02.003	VITE / SCREW / VIS / SCHRAUBE		1	
45	145 9132 000	V13.019	DADO / NUT / ECROU / MUTTER		1	
46	145 4794 000	-	SEGER / RETAINING RING / CIRCLIPS / SICHERUNGSRING		1	
47	145 1920 000	-	STAFFA / HANGER / ETRIER / BÜGEL		1	
48	145 4723 000	-	PORTACUSCINETTO / BALL BEARING HOLDER / ROULEMENT RACCORD / LAGERHALTER		1	
49	145 4720 000	-	CONTRALBERO / SHAFT / ARBRE / WELLE		1	
50	145 4795 000	-	CUSCINETTO / BALL BEARING / ROULEMENT / LAGER		2	

# ENGINE ASSEMBLY

Advance SW 850 G MODEL 908 3401 010

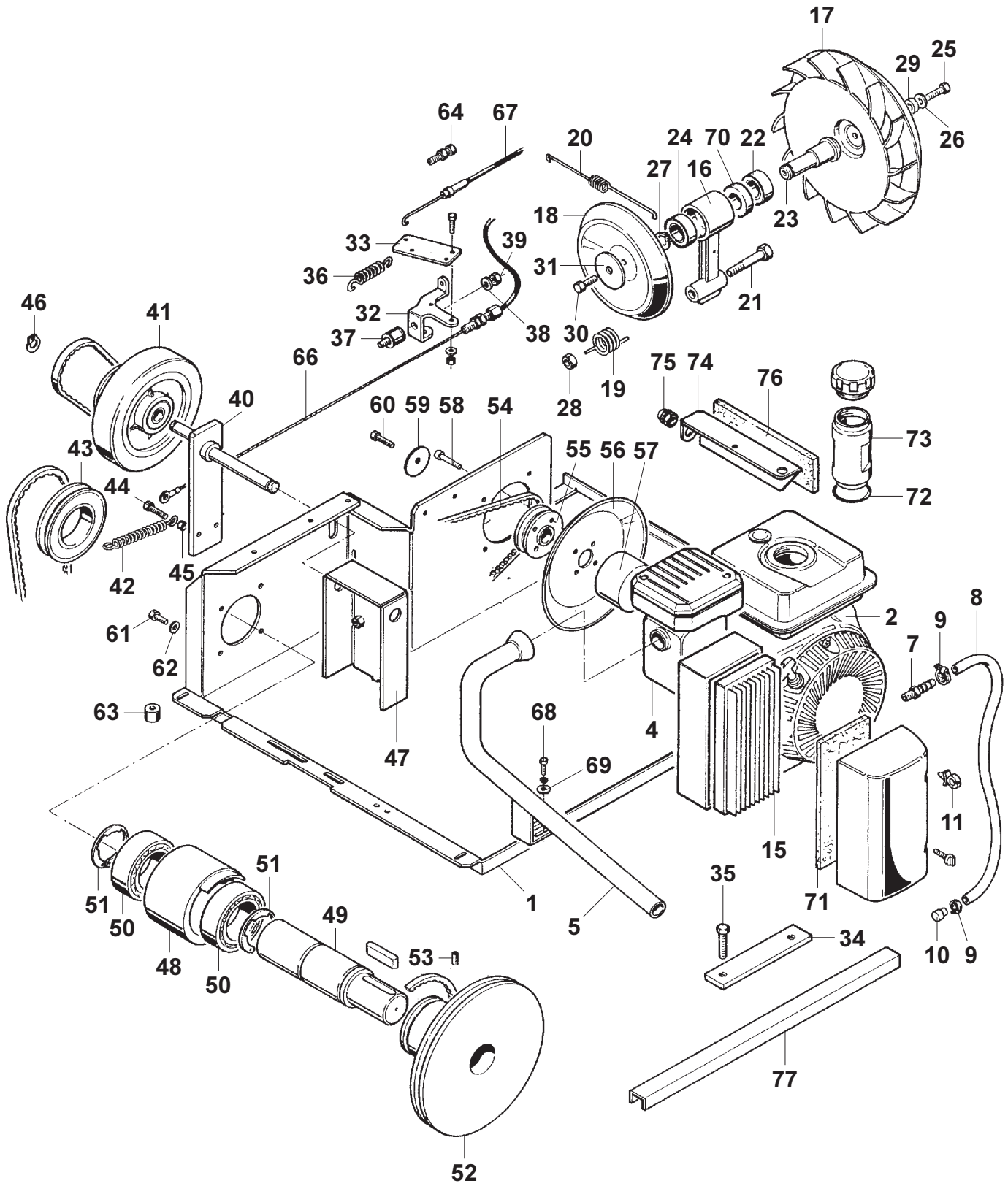

# ENGINE ASSEMBLY

POSIZ. ITEM POS. EINSAT.	CODICE CODE CODE NUMMER	CODICE INTERNO INTERNAL CODE CODE INTERIEUR INTERNE NUMMER	DESCRIZIONE DESCRIPTION DESCRIPTION BEZEICHNUNG	Advance SW 850 G MODEL 908 3401 010		
				B	G	O
51	145 4796 000	-	SEGER / RETAINING RING / CIRCLIPS / SICHERUNGSRING		2	
52	145 5472 000	-	PULEGGIA / PULLEY / POULIE / SCHEIBE		1	
53	145 4499 000	V08.00400	VITE / SCREW / VIS / SCHRAUBE		2	
54	145 9701 000	H00.028	CINGHIA / BELT / COURROIE / RIEMEN		1	
55	145 5471 000	-	PULEGGIA / PULLEY / POULIE / SCHEIBE		1	
56	145 4724 000	-	DISCO / PAD / DISQUE / DISK		1	
57	145 4733 000	-	MOZZO / HUB / MOYEU / NABE		1	
58	145 9253 000	V04.01300	VITE / SCREW / VIS / SCHRAUBE		4	
59	145 9213 000	V09.020	RONDELLA / WASHER / RONDELLE / BELAGSCHEIBE		1	
60	145 5064 000	V02.12870	VITE / SCREW / VIS / SCHRAUBE		1	
61	145 9261 000	V02.003	VITE / SCREW / VIS / SCHRAUBE		4	
62	145 9233 000	V19.004	RONDELLA / WASHER / RONDELLE / BELAGSCHEIBE		4	
63	145 8054 000	L02.07900	ANTIVIBRANTE / VIBRATION DAMPING / SILENT BLOC / SCHWINGUNGSDÄMPFER		3	
64	145 1179 000	E08.06800	REGISTRO M6 x 30 / ADJUSTMENT SCREW M6 x 30 / VIS DE REGULATION M6 x 30 / EINSTELLSCHRAUBE M6 x 30		1	
66	145 5310 000	-	CAVO TRAZIONE / CABLE / CABLE / KABEL		1	
67	145 1280 000	E08.15230	CAVO ASPIRAZIONE / CABLE / CABLE / KABEL		1	
68	145 9227 000	V02.004	VITE / SCREW / VIS / SCHRAUBE		2	
69	145 9128 000	V09.004	RONDELLA / WASHER / RONDELLE / BELAGSCHEIBE		2	
70	-	E05.041	DISTANZIALE / SPACER / ENTRETOISE / ABSTANDSSTÜCK		1	
71	145 6117 000	-	PROTEZIONE FILTRO / GUARD / PROTECTION / SCHUTZ		1	
72	145 0565 000	H04.10590	GUARNIZIONE / GASKET / JOINT / DICHTUNG		1	
73	146 0008 00	-	PROLUNGA PER TAPPO CARBURANTE / EXTENSION / RALLONGE / VERLAENGERUNG		1	
74	146 0003 00	-	SUPPORTO MANIGLIA AVVIAMENTO (SUL MOTORE) / SUPPORT / SUPPORT / HALTER		1	
75	146 0009 00	-	PASSACAVO / CABLE GUIDE / GUIDE CABLE / KABELFÜHRUNG		1	
76	146 0004 00	-	PANNELLO / PANEL / PANNEAU / PANEL		1	
77	-	-	CANALINA PROTEZIONE CAVI / CABLE PROTECTION / CABLE PROTECTION / LEITUNGSROHR		1	

# CONTROL PANEL

Advance SW 850 B MODEL 908 2213 010 - Advance SW 850 G MODEL 908 3401 010

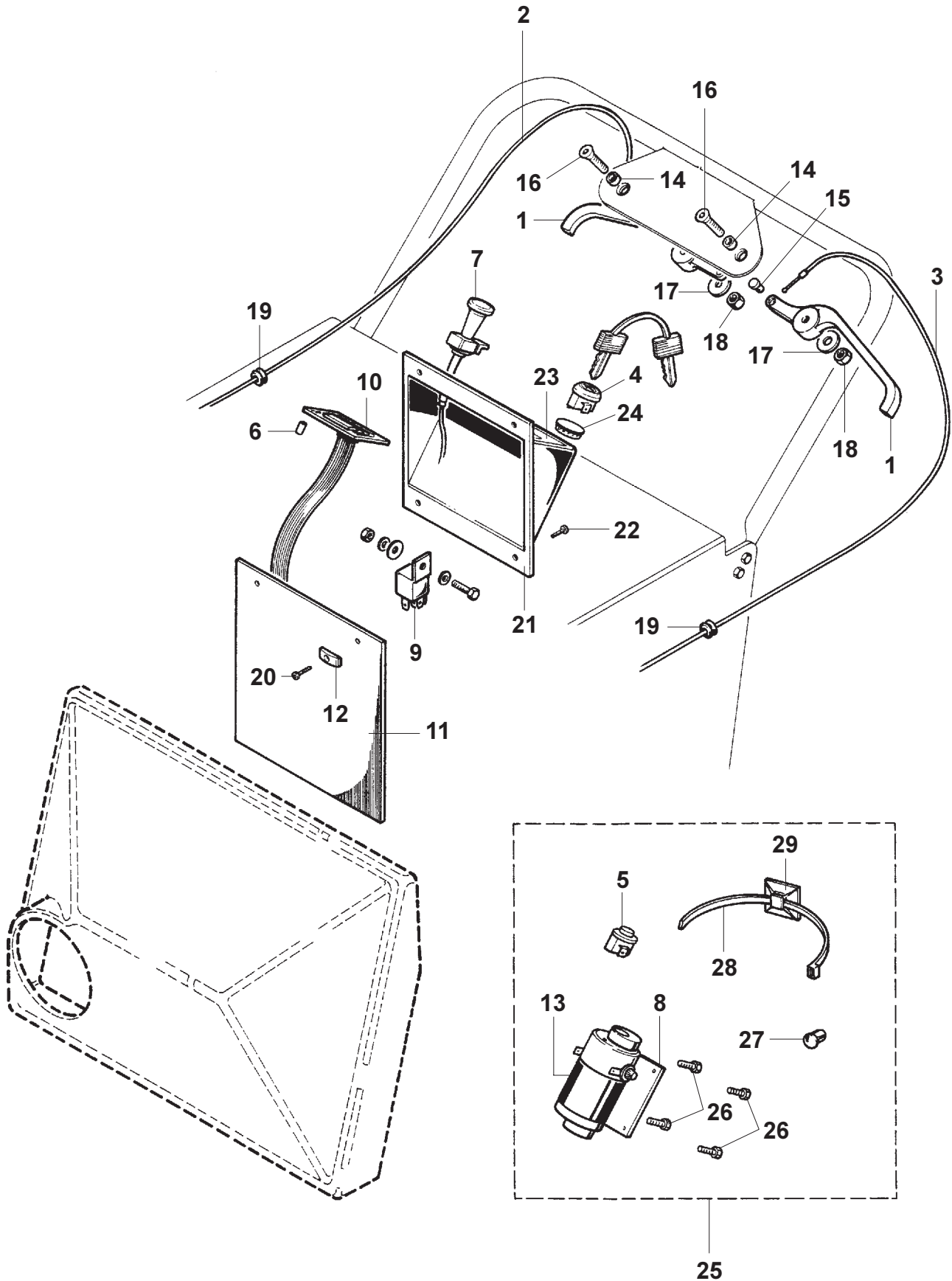

# CONTROL PANEL

POSIZ. ITEM POS. EINSAT.	CODICE CODE CODE NUMMER	CODICE INTERNO INTERNAL CODE CODE INTERIEUR INTERNE NUMMER	DESCRIZIONE DESCRIPTION DESCRIPTION BEZEICHNUNG	Advance SW 850 B MODEL 908 2213 010		
				B	G	O
1	145 4745 000	-	LEVA / LEVER / LEVIER / HEBEL	2	2	
2	145 5310 000	-	CAVO TRAZIONE / CABLE / CABLE / KABEL	1	1	
3	145 4766 000	-	CAVO ALZAFLAP / CABLE / CABLE / KABEL	1	1	
4	# 146 0006 00	G05.11130	INTERRUTTORE / SWITCH / INTERRUPTEUR / SCHALTER	1	1	
5	145 8885 000	G05.08200	PULSANTE / PUSH BUTTON / BOUTON POUSSOIR / KNOPF			1
6	145 0516 000	L02.13700	DISTANZIALE / SPACER / ENTRETOISE / ABSTANDSSTÜCK	3	3	
7	145 1280 000	E08.15230	CAVO ASPIRAZIONE / CABLE / CABLE / KABEL	1	1	
8	145 4818 000	-	PIASTRA / PLATE / PLAQUE / PLATTE			1
9	145 9377 000	G02.00700	RELE' / RELAY / RELAIS / RELAIS	1	1	
10	145 4803 000	-	SCHEDA / CARD / PLATINE / KARTE	1	1	
11	145 5017 000	-	GOMMA / PIPE / RACCORD / GUMMI	1	1	
12	145 1180 000	H01.26340	PIATTINA FLAP ANT. / PLATE / PLAQUE / BAND	2	2	
13	145 8105 000	A00.00801	KIT SCUOTIFILTRO EL. / KIT ELECTRIC FILTER SHAKER			1
14	145 4744 000	-	DISTANZIALE / SPACER / ENTRETOISE / ABSTANDSSTÜCK	4	4	
15	145 9279 000	E08.007	PERNO / PIN / AXE / STIFT	2	2	
16	145 0559 000	V06.00220	VITE / SCREW / VIS / SCHRAUBE	2	2	
17	145 9229 000	V09.022	RONDELLA / WASHER / RONDELLE / BEILAGSCHEIBE	2	2	
18	145 9132 000	V13.019	DADO / NUT / ECROU / MUTTER	2	2	
19	145 9246 000	G07.003	PASSACAVO / CABLE GUIDE / GUIDE CABLE / KABELFÜHRUNG	2	2	
20	145 1145 000	V03.03710	VITE / SCREW / VIS / SCHRAUBE	4	4	
21	145 4642 000	-	PLANCIA / PANEL / PLANCHE / PANEEL	1	1	
22	145 4775 000	-	VITE / SCREW / VIS / SCHRAUBE	4	4	
23	145 4751 000	-	SERIGRAFIA PLANCIA / PANEL / PLANCHE / PANEEL	1	1	
24	145 4270 000	L02.05900	TAPPO / CAP / BOICHON / PFROPFEN	1	1	
25	146 0163 00	-	KIT OPT. COMPLETO / KIT ELECTRIC FILTER SHAKER CPL.			1
26	145 9261 000	-	VITI / SCREWS			4
27	146 0165 000	-	COPERCHIO / CAP			1
28	145 8948 000	-	MORSETTO / CLAMP			1
29	145 0523 000	-	SUPPORTO / AD. SUPPORT			1

# HOPPER

Advance SW 850 B MODEL 908 2213 010 - Advance SW 850 G MODEL 908 3401 010

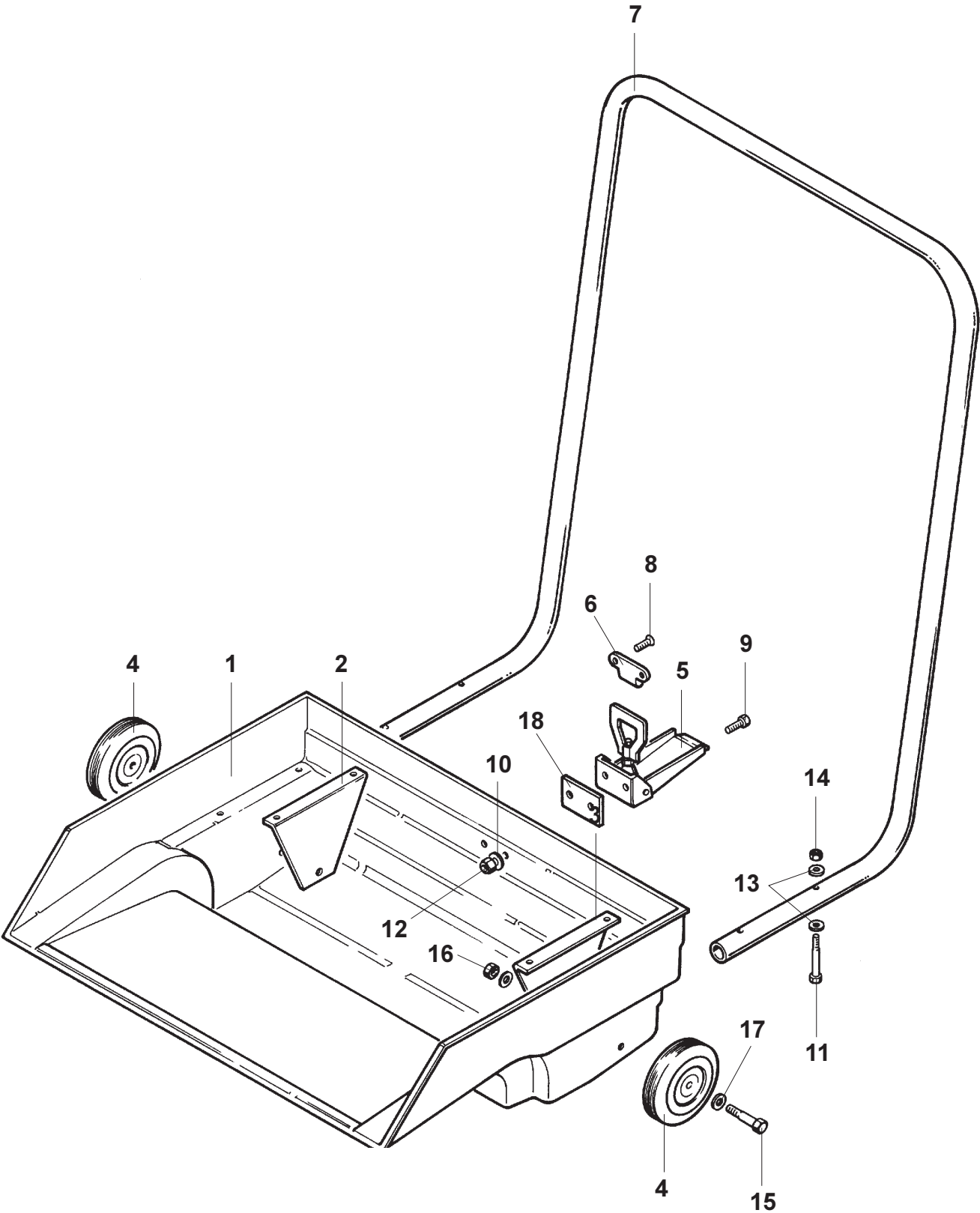

# HOPPER

POSIZ. ITEM POS. EINSAT.	CODICE CODE CODE NUMMER	CODICE INTERNO INTERNAL CODE CODE INTERIEUR INTERNE NUMMER	DESCRIZIONE DESCRIPTION DESCRIPTION BEZEICHNUNG	Advance SW 850 B MODEL 908 2213 010 Advance SW 850 G MODEL 908 3401 010		
				B	G	O
1	145 4839 000	-	CASSETTO / CONTAINER / DECHETS / BEHÄLTER	1	1	
2	145 1929 000	-	RINFORZO DX / REINFORCEMENT / RENFORT / VERSTÄRKUNG	1	1	
3	145 1928 000	-	RINFORZO SX / REINFORCEMENT / RENFORT / VERSTÄRKUNG	1	1	
4	145 4846 000	-	RUOTA / WHEEL / ROUE / RAD	2	2	
5	145 9136 000	L02.028	GANCIO / HOOK / CROCHET / HAKEN	1	1	
6	145 9148 000	F02.414	PIASTRINA / PLATE / PLAQUE / PLATTE	1	1	
7	145 4838 000	-	MANIGLIONE / HANDLE / POIGNE / HANDGRIFF	1	1	
8	145 5065 000	V03.019	VITE / SCREW / VIS / SCHRAUBE	2	2	
9	145 4481 000	V02.07400	VITE / SCREW / VIS / SCHRAUBE	2	2	
10	145 9254 000	V19.003	RONDELLA / WASHER / RONDELLE / BEILAGSCHEIBE	2	2	
11	145 4475 000	V02.031	VITE / SCREW / VIS / SCHRAUBE	4	4	
12	145 9134 000	V13.003	DADO / NUT / ECROU / MUTTER	2	2	
13	145 9120 000	V09.005	RONDELLA / WASHER / RONDELLE / BEILAGSCHEIBE	8	8	
14	145 9123 000	V13.005	DADO / NUT / ECROU / MUTTER	4	4	
15	145 1436 000	V02.08100	VITE / SCREW / VIS / SCHRAUBE	2	2	
16	145 9132 000	V13.019	DADO / NUT / ECROU / MUTTER	2	2	
17	145 9229 000	V09.022	RONDELLA / WASHER / RONDELLE / BEILAGSCHEIBE	2	2	
18	145 5246 000	-	PIASTRINA DI SPESSORE / SPACER / PLAQUE DE EPAISSEUR / DICKEPLATTE	1	1	



Nilfisk-Advance, Inc.  
14600 21st Avenue North  
Plymouth, MN, 55447-3408  
[www.nilfisk-advance.com](http://www.nilfisk-advance.com)  
Phone: 800-989-2235  
Fax: 800-989-6566

© 1999 Nilfisk-Advance, Inc.,  
Plymouth, MN 55447-3408  
Printed in the U.S.A.