



Electronic Service Manuals

This electronic document is provided as a service to our customers. We do not create the contents of the information contained in this document. Should you have detailed questions pertaining to the information contained in this document, you may contact Michco, or the manufacturer which provided the original information in this electronic deliverable. Michco's only part in this electronic deliverable was the electronic assembly process.

You may contact Michco through the following methods:
Phone (517) 484-9312 or (800) 331-3339 MI, OH, IN only
2011 N. High St. -- Lansing, Michigan -- 48906
Fax: (517) 484-9836
Email: CustServ@Michco.com
Web site: www.Michco.Com
Parts Web site: www.FloorMachineParts.Com

Order Parts on Line at:
www.FloorMachineParts.Com

Directly to Parts & Service:
By Email: **Shop@Michco.com**
By Fax: (517) 702-2041
By Voice: Use numbers above.

Serving the Cleaning Industry Since 1922

Notice: All copyrighted material remains property of original owners, all trademarks are property of respective owners. Manuals are subject to Manufacturer's reproduction limitations. Originals or reproductions were provided by manufacturers through a request. We make no warranty as to the correctness of information provided in this document and you assume all risk.

Whirlamatic™ 20 Ultra

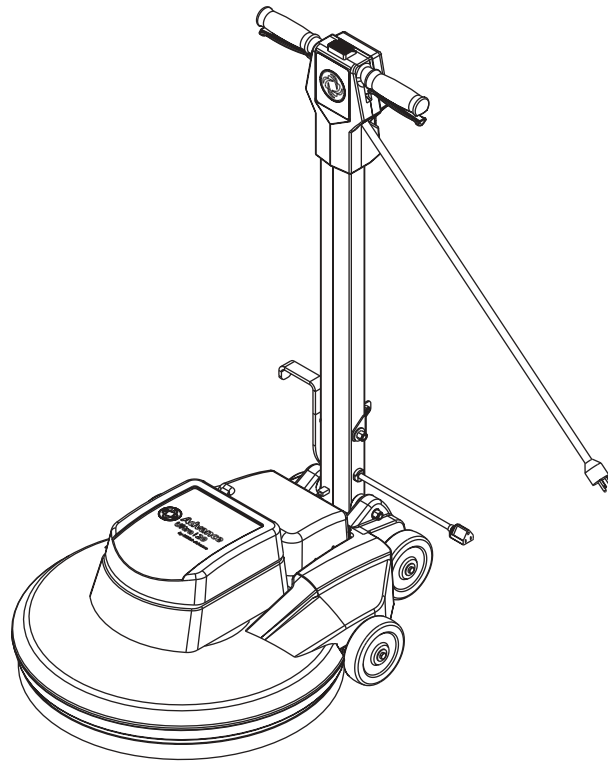

PARTS LIST

Advance MODEL 56201503



Advance

by Nilfisk-Advance

12/96 revised 10/02 FORM NO. 56042318

DESCRIPTION	PAGE
Handle System	4-5
Base System/Wiring Diagram	6-7

WHEN ORDERING PARTS

- * Use the 8 digit numbers from the "Ref. No." columns in this parts list.
- * Specify the model and serial number of the machine.
- * Use the space below to record the model and serial number for future reference.

Model _____ Serial No. _____

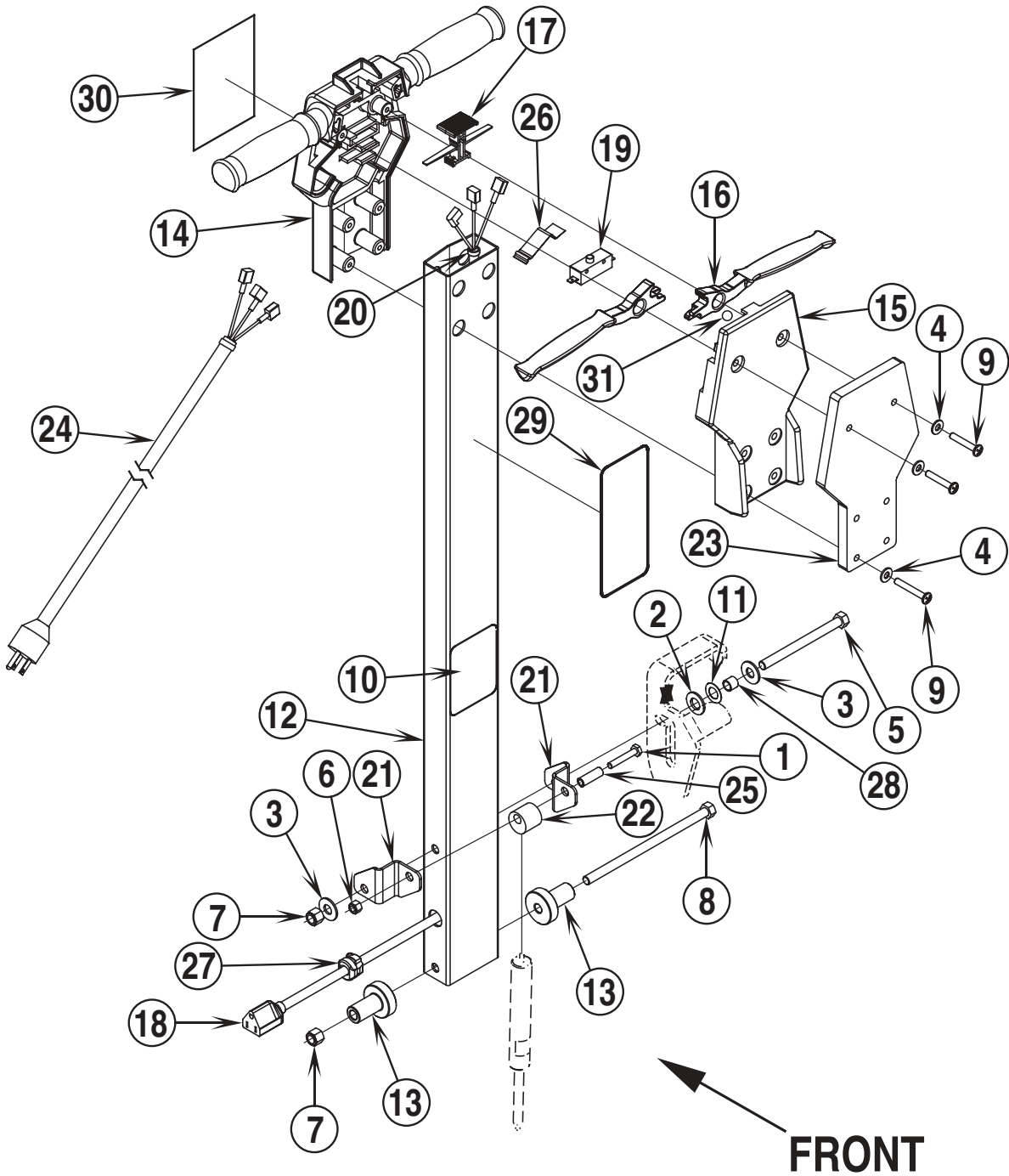

96-12	HANDLE SYSTEM		
02-10	Whirlamatic™ 20 Ultra		5

Item	Ref. No.	Qty	Description
1	56001833	1	Scr, Hex Hd 1/4-20 x 1.50
2	56009003	1	Wsh, Flt .516 x .938 x .075
3	56002055	2	Wsh, Flt STD 3/8
4	56002098	6	Wsh, Flt SAE 1/4 (before SN 1403694)
5	56009241	1	Scr, Hex Hd 3/8-16 x 4.25
6	56002708	1	Nut, Hex Nyl Loc 1/4-20
7	56002769	2	Nut, Hex Nyl Loc 3/8-16
8	56002777	1	Scr, Hex Hd 3/8-16 x 7.00
9	56002786	6	Scr, Pan Phil 1/4-20 x 1.50 (before SN 1403694)
	56002108	6	Scr, Pan Phil 1/4-20 x 2.00 (after SN 1403693)
10	56016064	1	Decal, Latch
11	56009001	1	Wsh, Bowed .51 x .90 x .008
12	56201056	1	Handle Tube (before SN 1403694)
	56201509	1	Handle Tube (after SN 1403693)
13	56201016	2	Bushing
14	56201054	1	Handle
15	56201026	1	Handle Cover
16	56201027	2	Handle Lever
17	56201031	1	Button, Lock
18	56201033	1	Cord Assembly 14/3
19	56201034	1	Switch, N.O. SPST Snap
20			Intentionally Omitted
21	56201523	2	Bracket
22	56201525	1	Mount, Cylinder
23	56201526	1	Weight, Handle (before SN 1403694)
	56201507	1	Weight, Handle (after SN 1403693)
24	56201530	1	Cord Set, 14/3 x 75'
25	56201531	1	Bushing
26	56263648	1	Spring, Plate
27	56382818	1	Strain Relief
28	56388326	1	Bushing
29	56014828	1	Decal, Warning
30	56016429	1	Decal, Logo
31	56201592	1	Ball, 1/4 SS

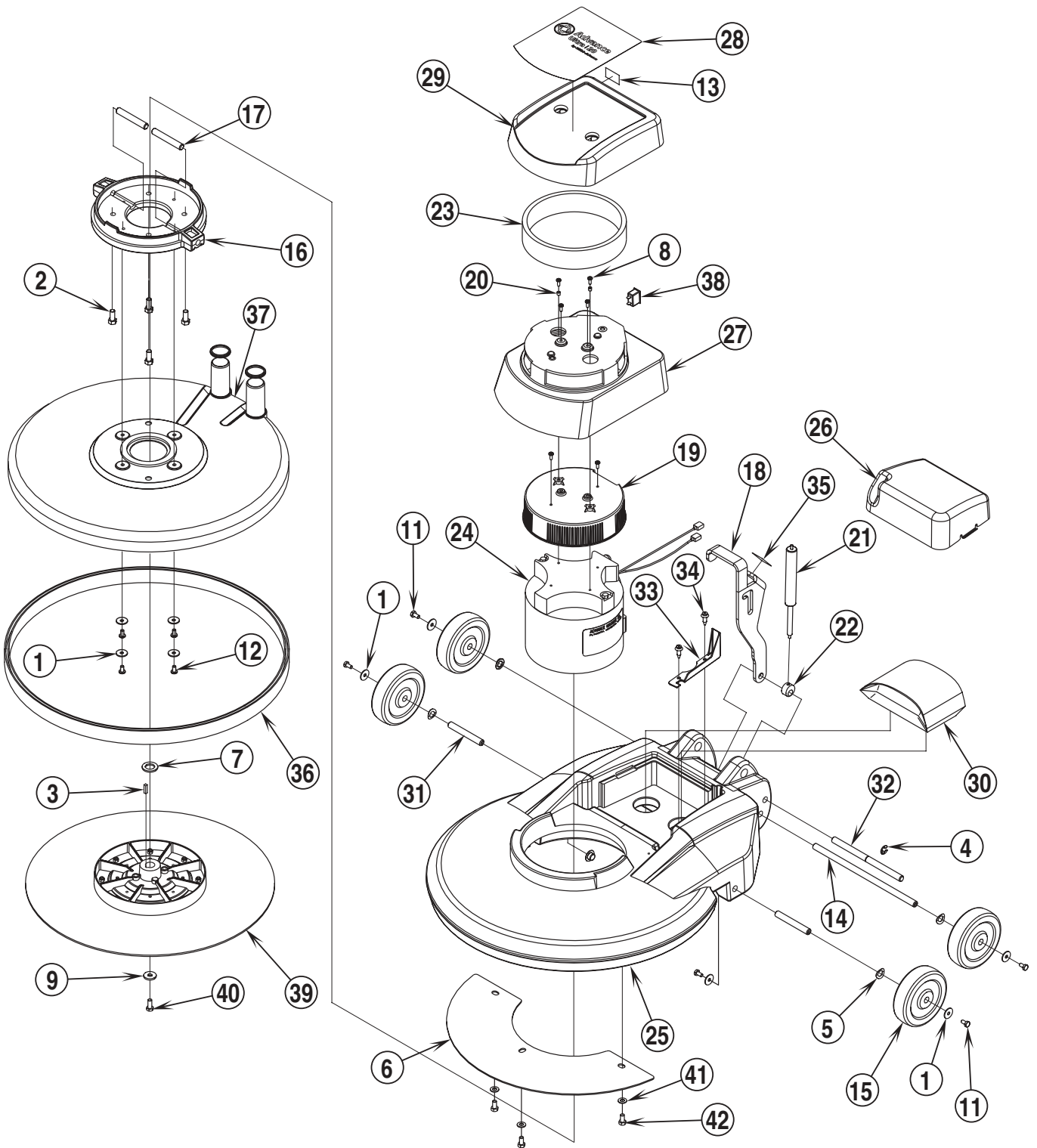

Item	Ref. No.	Qty	Description	Item	Ref. No.	Qty	Description
1	56009002	10	Wsh, Flt .26 x .90 x .06	25	56201543	1	Base Housing
2	56002271	4	Scr, Hex Hd 3/8-16 x .88	26	56201553	1	Shroud, Vac
3	56003238	1	Key, Sq. .19 x .78	27	56201554	1	Shroud, Motor
4	56003264	1	Ring, Ret. Ext. Type E	28	56016428	1	Decal, Cover
5	56009001	A/R	Wsh, Bowed .51 x .906 x .008	29	56201558	1	Cover, Motor
6	56201585	1	Plate	30	56201569	A/R	Bag, Vac (10 pack)
7	56009022	1	Wsh, Flt .75 x 1.25 x .12	31	56201090	2	Pin, Axle
8	56009029	6	Scr, Pan Phil Thd Form 10-24 x .50	32	56201562	1	Pin
9	56009057	1	Wsh, Flt Harden .34 x 1.00 x .12	33	56201563	1	Cover, Cord
10			Intentionally Omitted	34	56201564	2	Panel Fastener
11	56003039	6	Scr, Hex Loc 1/4-20 x .50	35	56201572	1	Grip Surface
12	56009062	4	Scr, Pan Phil Thd Form 1/4-20 x .50	36	56393565	1	Skirt Assembly
13	56015914	1	Decal, Brush Wear Indicator	37	56201571	1	Shroud Assembly TSB 689
14	56201089	1	Axle		56201617	1	Gasket
15	56201018	4	Wheel 5.00 x 1.50	38	56249527	1	Brush Wear Indicator Light 115V
16	56201591	1	Cup	39	56505194	1	Pad Holder Assy
17	56201515	2	Pin	*	56393567	1	Pad Retainer
18	56201516	1	Latch	40	56002956	1	Scr, Hex Hd Loc 5/16-18 x .75
19	56201576	1	Guard	41	56001939	3	Wsh, Flt SAE 5/16
20	56201521	2	Bushing	42	56002035	3	Scr, Hex Hd 5/16-18 x .62
21	56201522	1	Spring, Gas Cylinder	**	56388354	1	Pad, Burnishing 20" (case of 5)
22	56201524	1	End Fitting	**	56505551	1	Union Mix Brush, Burnishing 20"
23	56201528	1	Filter	**	56505550	1	Tampico Brush, Burnishing 20"
24	56201541	1	Motor, 120V 1.5HP, 2000RPM				* = Not Shown
*	56201551	1	Armature w/bearings				** = Not Included
*	56183563	1	Carbon Brush (set of four)				
*	56183569	1	Carbon Brush Springs (set of four)				
*	56180163	1	Rectifier				
*	56378380	1	Top Bearing				
*	56372773	1	Bottom Bearing				
*	56183016	1	Commutator Bracket				
*	56201547	1	Brush Board Assy				

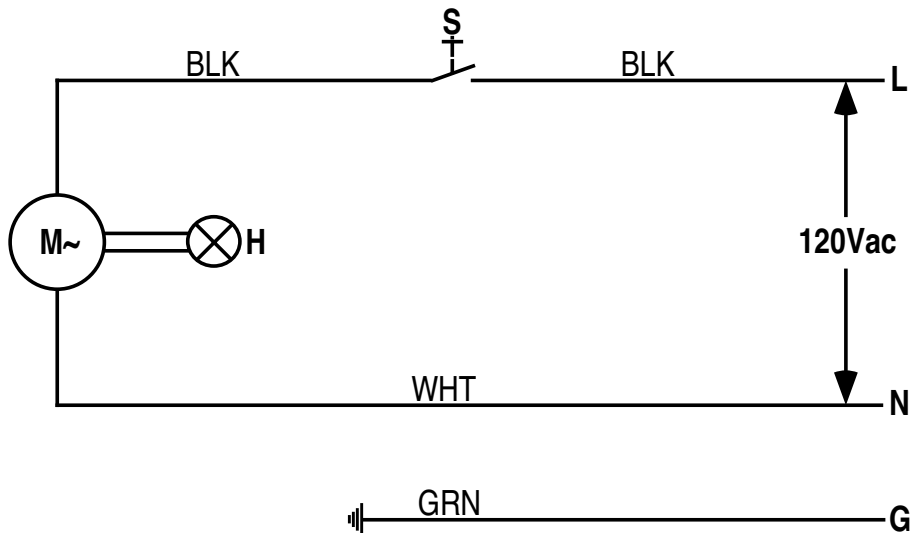

Item	Ref. No.	Qty	Description
S	56201034	1	Switch, N.O. SPST Snap
M	56201541	1	Motor, 120V 1.5HP, 2000RPM
H	56249527	1	Brush Wear Indicator Light



Nilfisk-Advance, Inc.
14600 21st Avenue North
Plymouth, MN, 55447-3408
www.nilfisk-advance.com
Phone: 800-989-2235
Fax: 800-989-6566
©2002 Nilfisk-Advance, Inc.,
Plymouth, MN 55447-3408
Printed in the U.S.A.