



Electronic Service Manuals

This electronic document is provided as a service to our customers. We do not create the contents of the information contained in this document. Should you have detailed questions pertaining to the information contained in this document, you may contact Michco, or the manufacturer which provided the original information in this electronic deliverable. Michco's only part in this electronic deliverable was the electronic assembly process.

You may contact Michco through the following methods:
Phone (517) 484-9312 or (800) 331-3339 MI, OH, IN only
2011 N. High St. -- Lansing, Michigan -- 48906
Fax: (517) 484-9836
Email: CustServ@Michco.com
Web site: www.Michco.Com
Parts Web site: www.FloorMachineParts.Com

Order Parts on Line at:
www.FloorMachineParts.Com

Directly to Parts & Service:
By Email: **Shop@Michco.com**
By Fax: (517) 702-2041
By Voice: Use numbers above.

Serving the Cleaning Industry Since 1922

Notice: All copyrighted material remains property of original owners, all trademarks are property of respective owners. Manuals are subject to Manufacturer's reproduction limitations. Originals or reproductions were provided by manufacturers through a request. We make no warranty as to the correctness of information provided in this document and you assume all risk.

SDH 5115

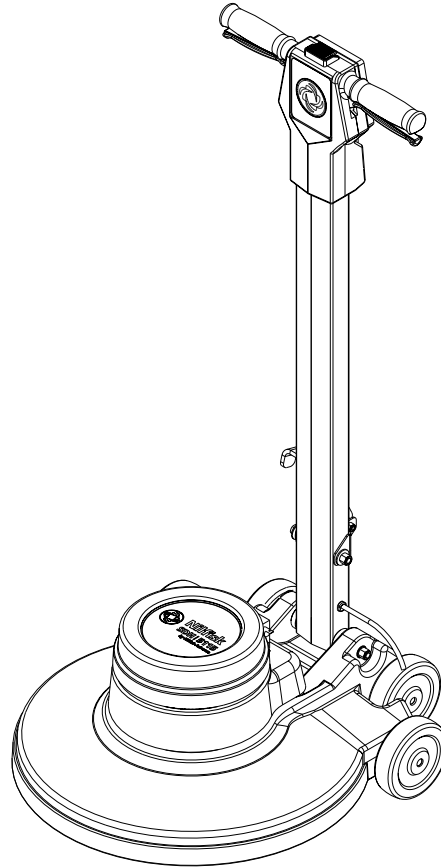

PARTS LIST **Nilfisk MODEL 56201956**



Nilfisk
Advance
setting standards

1/00 revised 10/03 FORM NO. 56042408
BOOK D - SECTION 3.3.1

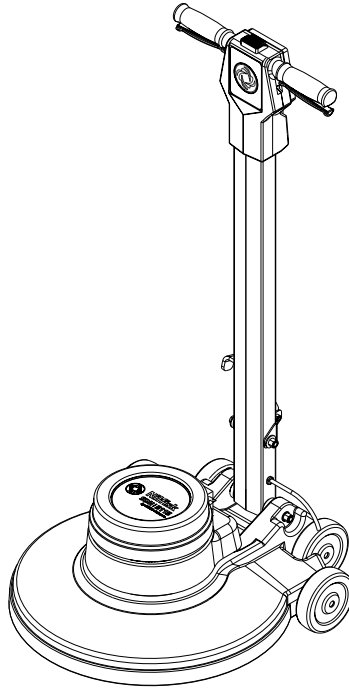
**DESCRIPTION****PLAN**

HANDLE SYSTEM	D-3.3.1-5
BASE SYSTEM / WIRING DIAGRAM	D-3.3.1-7

WHEN ORDERING PARTS

- * Use the 8 digit numbers from the "Ref. No." columns in this parts list.
- * Specify the model and serial number of the machine.
- * Use the space below to record the model and serial number for future reference.

Model _____ Serial No. _____

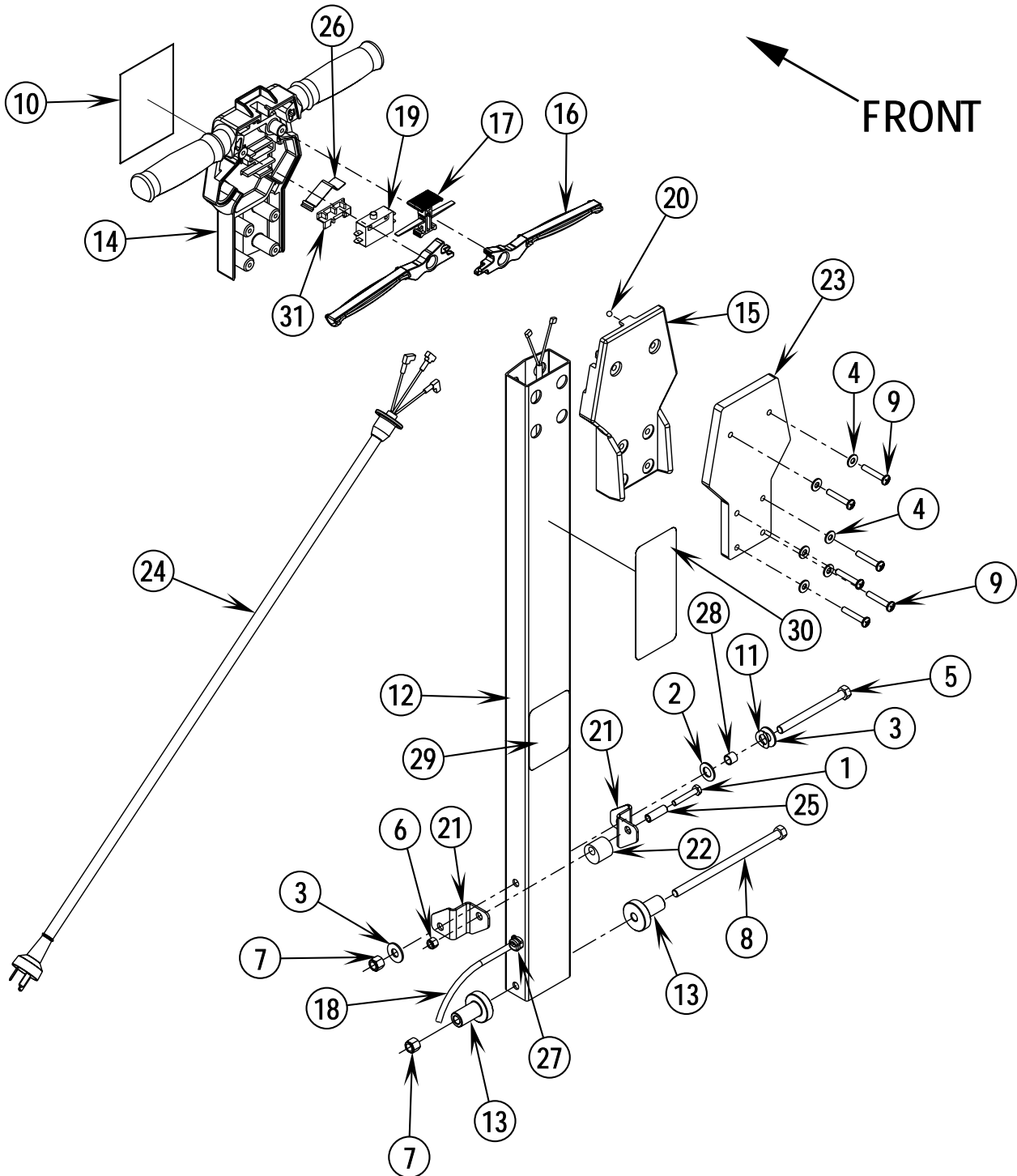

00-1	HANDLE SYSTEM	BOOK D		
03-10	SDH 5115	D	3.3.1	5

Item	Ref. No.	Qty	Description
1	56001833	1	Scr, Hex Hd 1/4-20 x 1.50
2	56009003	1	Wsh, Flt 1/2
3	56002055	2	Wsh, Flt STD 3/8
4	56002098	6	Wsh, Flt SAE 1/4 (before SN 1402031)
5	56009241	1	Scr, Hex Hd 3/8-16 x 4.25
6	56002708	1	Nut, Hex Nyl Loc 1/4-20
7	56002769	2	Nut, Hex Nyl Loc 3/8-16
8	56002777	1	Scr, Hex Hd 3/8-16 x 7.00
9	56002786	6	Scr, Pan Phil 1/4-20 x 1.50 (before SN 1402031)
	56002108	6	Scr, Pan Phil 1/4-20 x 2.00 (after SN 1402030)
10	56016426	1	Decal, Logo
11	56009001	1	Wsh, Bowed .51 x .90 x .008
12	56201587	1	Handle Tube (before SN 1402031)
	56201510	1	Handle Tube (after SN 1402030)
13	56201016	2	Bushing
14	56201560	1	Handle
15	56201058	1	Handle Cover
16	56201027	2	Handle Lever
17	56201031	1	Button, Lock
18	56201574	1	Cord Assembly 14/3
19	56201648	1	Switch, N.O. DPDT Snap TSBUS2003-857
20	56201592	1	Ball
21	56201523	2	Bracket
22	56201525	1	Mount, Cylinder
23	56201526	1	Weight, Handle (before SN 1402031)
	56201507	1	Weight, Handle (after SN 1402030)
24	56201573	1	Power Cord
25	56201531	1	Bushing
26	56263648	1	Spring, Plate
27	56201596	1	Strain Relief
28	56388326	1	Bushing
29	56016064	1	Decal, Latch
30	56014828	1	Decal, Warning
31	56201647	1	Spacer, Plastic TSBUS2003-857

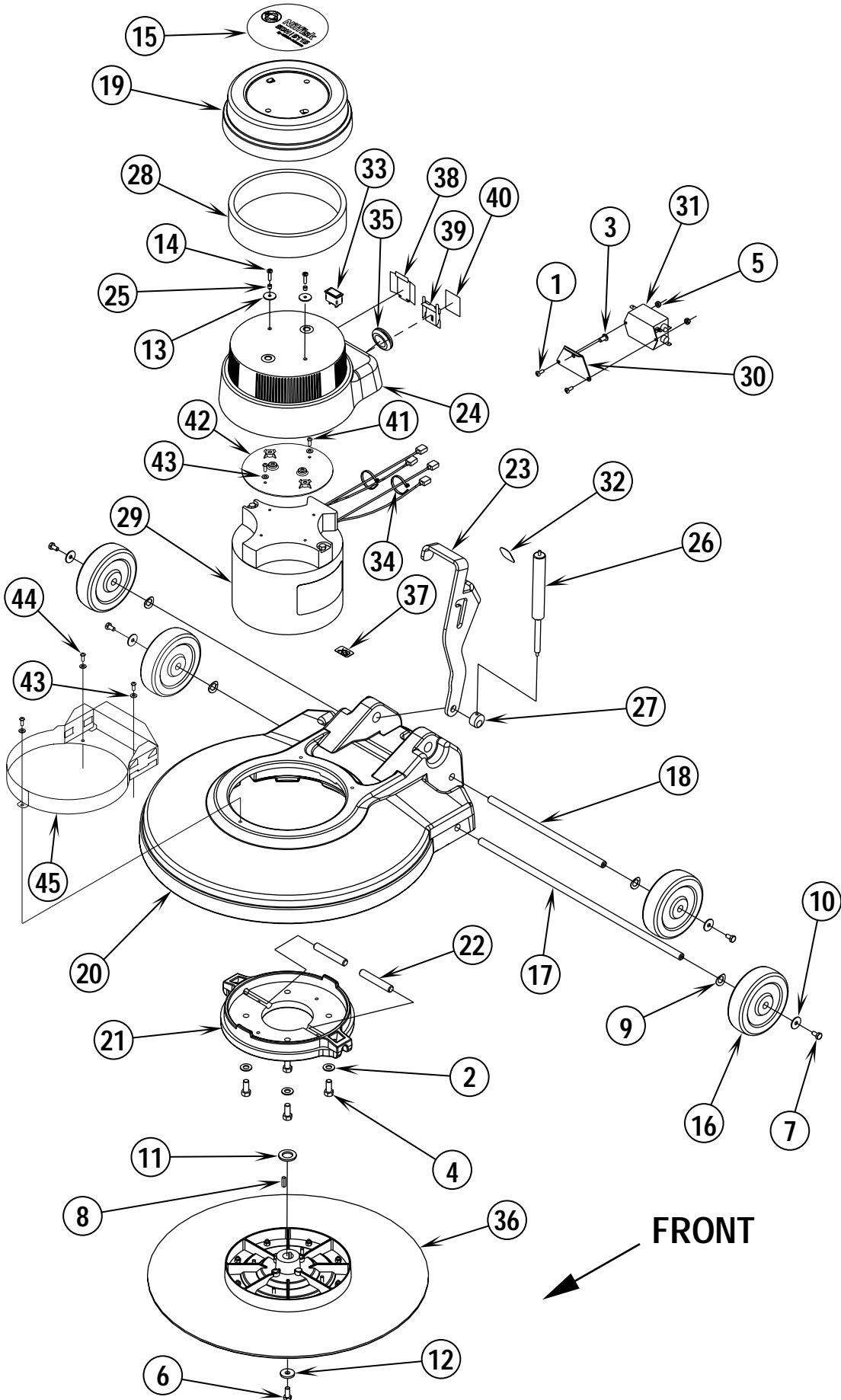

Item	Ref. No.	Qty	Description	Item	Ref. No.	Qty	Description
1	56001993	1	Scr, Pan Phil 10-24 x .50	29	56330938	1	Motor 230V, 1500RPM, 1.5HP
2	56002063	4	Wsh, Flt SAE 3/8	*	56201580	1	Armature Assy. W/Brg's
3	56002145	1	Scr, Pan Phil 1/4-20 x .50	*	56183016	1	Bracket Commutator
4	56002271	4	Scr, Hex Hd 3/8-16 x .88	*	56201581	1	Brush Board Assy.(includes brushes, springs, detectors, varistor & leads)
5	56002832	2	Nut, Hex Nyl Loc-Thin 10-24				
6	56002956	1	Scr, Hex Hd Loc 5/16-18 x .75	*	56183569	1	Spring (qty of 4 required per motor)
7	56003039	4	Scr, Hex Hd Loc 1/4-20 x .50	*	56201582	1	Brush Assy. (qty of 4 required per motor)
8	56003238	1	Key, SQ .19 x .78	*	56183583	1	End Bell Shaft End
9	56009001	4	Wsh, Bowed .516 x .906 x .008	*	56372773	1	Bearing – Shaft End
10	56009002	4	Wsh, flt .266 x .906 x .060	*	56378380	1	Bearing – Top End
11	56009022	1	Wsh, Flt .754 x 1.250 x .120	*	56180163	1	Rectifier
12	56009057	1	Wsh, Flt Harden .344 x 1.00 x .120	30	56201556	1	Bracket
13	56009096	2	Wsh, Flt .193 x .875 x .060	31	56201557	1	Filter, RFI
14	56009209	2	Scr, Pan Phil Thd Form 10-24 x 1.00	32	56201572	1	Grip Surface
15	56016561	1	Decal, Cover SDH 5115	33	56755578	1	Indicator Light 220-240V
16	56201018	4	Wheel 5.00 x 1.50	34	56478246	2	Cable Tie
17	56201088	1	Axle	35	56486116	1	Grommet (before SN1436128)
18	56201089	1	Axle	36	56201534	1	Pad Holder Assy.
19	56201321	1	Cover, Motor	37	56015914	1	Decal, Brush Wear Indicator
20	56201512	1	Base Housing	38	56201540	1	Cover, Double Insulator NOTE
21	56201513	1	Cup	39	56201544	1	Plug, Double Insulator NOTE
22	56201515	2	Pin	40	56015000	1	Decal, Plug NOTE
23	56201516	1	Latch	41	56009029	2	Scr, Pan Phil Thd Form 10-24 x .50 NOTE
24	56201519	1	Shroud	42	56201583	1	Spacer, Insulator NOTE
25	56201521	2	Bushing	43	56001954	5	Wsh, Flt SAE #10 NOTE
26	56201522	1	Spring, Gas	44	56009191	3	Scr, Pan Phil Plastite 10-14 x .50 NOTE
27	56201524	1	End Fitting	45	56201536	1	Ring, Insulator NOTE
28	56201528	1	Filter	**	56388354	1	Pad, Burnishing 20" (case of 5)
				**	56505551	1	Union Mix Brush, Burnishing 20"
				**	56505550	1	Tampico Brush, Burnishing 20"

* = Not Shown

** = Not Included

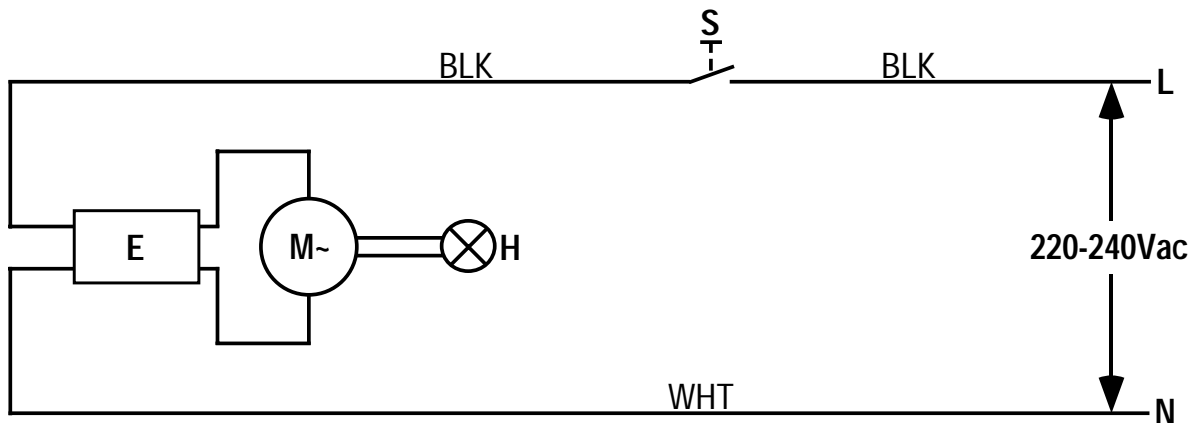
NOTE: These parts are only used after SN1436127.

Item	Ref. No.	Qty	Description	Item	Ref. No.	Qty	Description
S	56201648	1	Switch DPDT, NO TSBUS2003-857	**	56183569	1	Spring (qty of 4 required per motor)
H	56755578	1	Brush Wear Indicator Light 220-240V	**	56201582	1	Brush Assy. (qty of 4 required per motor)
E	56201557	1	Filter, RFI	**	56183583	1	End Bell Shaft End
M	56330938	1	Motor 230V, 1500RPM, 1.5HP	**	56372773	1	Bearing – Shaft End
**	56201580	1	Armature Assy. W/Brg's	**	56378380	1	Bearing – Top End
**	56183016	1	Bracket Commutator	**	56180163	1	Rectifier
**	56201581	1	Brush Board Assy.(includes brushes, springs, detectors, varistor & leads)	**			Optional replacement parts for 56330938

DANMARK

Nilfisk-Advance Nordic A/S
Sognevej 25 - Box 344
DK-2605 Broendby
☎ 43 23 83 50 – Fax 43 42 15 95

NORGE

Nilfisk-Advance AS
Enebakvn, 119, 0680 Oslo, Postboks 196, Manglerud,
0612 Oslo
☎ 22 08 63 50 – Fax 22 08 63 63
Distriktsrepresentanter over hele landet

SVERIGE

Nilfisk-Advance AB
Sjöbjörnsvägen 5, 117 67 Stockholm
☎ 085 55 944 00 – Fax 085 55 944 30

FINLAND/ SUOMI

BERNER Ltd. Facotek Department
Etäleranta 4B, 00130 Helsinki
☎ +358 9 1345 1382

AUSTRALIA

Nilfisk-Advance Pty. Ltd.
48 Egerton Street
Silverwater NSW 2128
☎ (02) 8748 5905 – Fax (02) 9648 2711
Customer Responce Centre:
☎ 1 800 011 013

BELGIQUE / BELGIË/ LUXEMBOURG

Nilfisk-Advance s.a./n.v.
Doornveld/ Sphere Business Park
Industrie Asse 3, nr 11 – bus 41
1731 Zellik-Asse
☎ (02) 467.60.50 Fax (02) 463.44.16

CANADA

Nilfisk-Advance Ltd.
396 Watline Avenue
Mississauga, Ontario L4Z 1X
☎ (905) 712-3260 – Fax (905) 712-3255

DEUTSCHLAND

Nilfisk-Advance AG
Siemensstraße 25-27
25462 Rellingen
☎ (041 01) 3990 – Fax (04101) 399191
Zentraler Kundenservice
☎ für die Industrie: 0180 535 67 97
☎ Institutionen und Gebäudereiniger: 0180 500 11 70

FRANCE

Nilfisk-Advance S.A.
BP 246
91944 Courtaboeuf Cedex
☎ (01) 69.59.87.00 Télécopie (01) 69.59.87.01

HONG KONG

Nilfisk-Advance Ltd.
2001, 20/F HK Worsted Mills
Industrial Building
31-39 Wo Tong Tsui Street
Kwai Chung, N.T.
☎ 2427 59 51 – Fax 2487 5828

IRELAND

Nilfisk-Advance Ltd.
28 Sandford Office Park
Dublin 18
☎ +353 1 2943838 – Fax +353 1 2943845

JAPAN

Nilfisk-Advance Inc.
3-4-9 Chigasaki Minami
Tsuzuki-Ku Yokohama 224 0037
☎ 045-942-7741 – Fax 045-942-6545

MALAYSIA

Nilfisk-Advance Sdn Bhd
Lot 2, 1st. Floor
Lorong 19/1A
46300 Petaling Jaya
Selangor Darul Ehsan
☎ 03-7568188/03-7568189/03-7568388 – Fax 03-7566828

NEDERLAND

Nilfisk-Advance B.V.
Flevolaan 7, Postbus 341
1380 AH Weesp
☎ 0294-462121 – Fax 0294-430053

NEW ZEALAND

Nilfisk-Advance Limited
477 Great South Road, Penrose
Auckland
☎ (09) 525 0092 – Fax (09) 525 6440

SCHWEIZ / SUISSE

Nilfisk-Advance AG
Ringstrasse 19, 9533 Kirchberg/Wil
☎ 719 23 52 83 – Fax 719 23 84 44

SINGAPORE

Nilfisk-Advance Pte. Ltd.
22, Woodlands Industrial Park E1
Singapore 757740
☎ (65) 759 9100 – Fax (65) 759 9133

TAIWAN

Nilfisk-Advance Ltd.
1 F, No.23, Lane 132, Sec. 2
Ta An Road, Taipei
☎ 700 22 68 – Fax 784 08 43

UNITED KINGDOM

Nilfisk-Advance Limited
Newmarket Road
Bury St. Edmunds
Suffolk IP 33 3SR
☎ (01284) 763163 – Fax (01284) 750562

USA

Nilfisk-Advance Inc.
14600 21st Avenue North
Plymouth, MN 55447-3408
☎ +1 800 989 2235 – Fax 1 800 989 6566

Nilfisk-Advance of America, Inc.
300 Technology Drive
Malvern, PA 19355
☎ (610) 647 647-6427

ÖSTERREICH

Nilfisk-Advance GmbH
Vorarlberg Allee 46
1230 Wien
☎ 1 616 58 30 – Fax 1 616 58 30 40

ESPAÑA

Nilfisk-Advance, S.A.
Torre D'Ara
Passeig del Rengle, 5 Pl.9-10
E-08302 – Mataró (Barcelona)
☎ Tel. 93 741 24 00 – Fax: 93 757 80 20
Central atención al cliente: 902 200 201
nilfisk@nilfisk-advance.es – www.nilfisk-advance.com
Distribuidores y Servicio Técnico en toda España y Andorra

ITALIA

Nilfisk-Advance Italia Spa
Località Novella Terza
26862 Guardamiglio (LO)
Italy
☎ +39 0377 414067-54 – Fax +39 0377 414097
www.nilfisk-advance.com

PORTUGAL

Nilfisk-Advance Lda.
Rua Cândido de Figueiredo, 91-i, 1500-133 LISBOA
☎ 01/7784142 – Fax 01/7785613
Porto 02/526766 – Fax 02/520739
Açores 096/628092/3 – Fax 096/628129
Madeira 091/228965 – Fax 091/228796

GREECE

Embiom S.A.
Λεωφ. Βουλιαγμένης 60
Αργυρούπολη
164 52 Αθήνα
☎ 9950613 - Fax 9951680

