



Electronic Service Manuals

This electronic document is provided as a service to our customers. We do not create the contents of the information contained in this document. Should you have detailed questions pertaining to the information contained in this document, you may contact Michco, or the manufacturer which provided the original information in this electronic deliverable. Michco's only part in this electronic deliverable was the electronic assembly process.

You may contact Michco through the following methods:
Phone (517) 484-9312 or (800) 331-3339 MI, OH, IN only
2011 N. High St. -- Lansing, Michigan -- 48906
Fax: (517) 484-9836
Email: CustServ@Michco.com
Web site: www.Michco.Com
Parts Web site: www.FloorMachineParts.Com

Order Parts on Line at:
www.FloorMachineParts.Com

Directly to Parts & Service:
By Email: **Shop@Michco.com**
By Fax: (517) 702-2041
By Voice: Use numbers above.

Serving the Cleaning Industry Since 1922

Notice: All copyrighted material remains property of original owners, all trademarks are property of respective owners. Manuals are subject to Manufacturer's reproduction limitations. Originals or reproductions were provided by manufacturers through a request. We make no warranty as to the correctness of information provided in this document and you assume all risk.

AquaClean™ 12/15/18

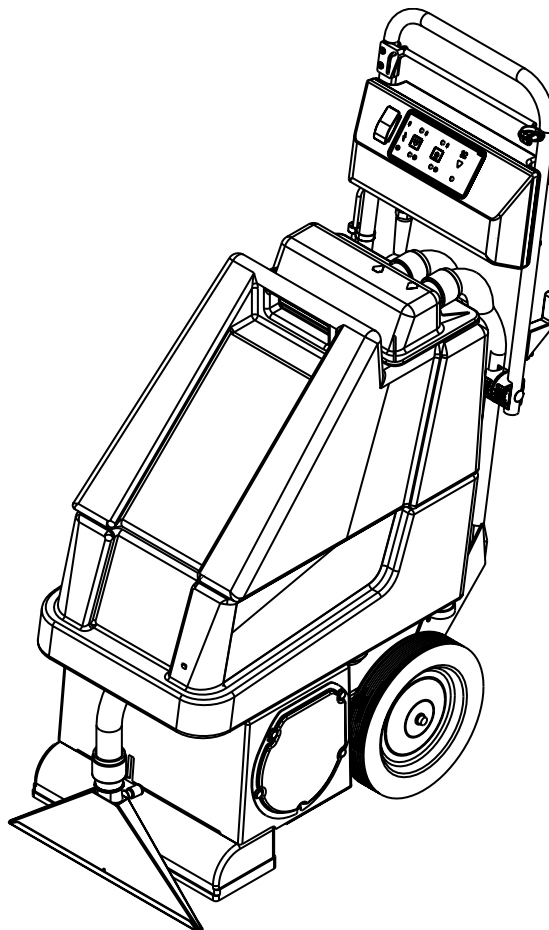

PARTS LIST

Advance MODELS 56264058, 56264001, 56264059, 56264060,
56264061, 56264062

This parts list is for machines after serial number 1006184



Advance
by Nilfisk-Advance

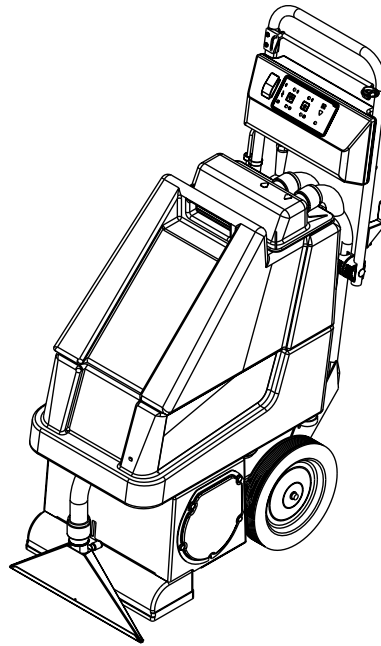

DESCRIPTION	PAGE
UPPER HANDLE SYSTEM	2-3
CONSOLE ASSEMBLY	4-5
LOWER HANDLE SYSTEM	6-7
CHASSIS SYSTEM	8-9
BRUSH SYSTEM	10-11
SOLUTION SYSTEM	12-13
FLOW DIVERTER ASSEMBLY	14-15
RECOVERY SYSTEM	16-17
DECAL SYSTEM	18-19
ELECTRICAL DIAGRAMS	20-27
HARD FLOOR KITS	28-29
SQUEEGEE MOUNT ASSEMBLY	30-31
SQUEEGEE ASSEMBLY	32-33
OPTIONAL HARD FLOOR BRUSHES & ACCESSORY TOOLS	34

WHEN ORDERING PARTS

- * Use the 8 digit numbers from the "Ref. No." columns in this parts list.
- * Specify the model and serial number of the machine.
- * Use the space below to record the model and serial number for future reference.

Model _____ Serial No. _____

UPPER HANDLE ASSEMBLY

94-5

2

AquaClean™ 12/15/18

02-7

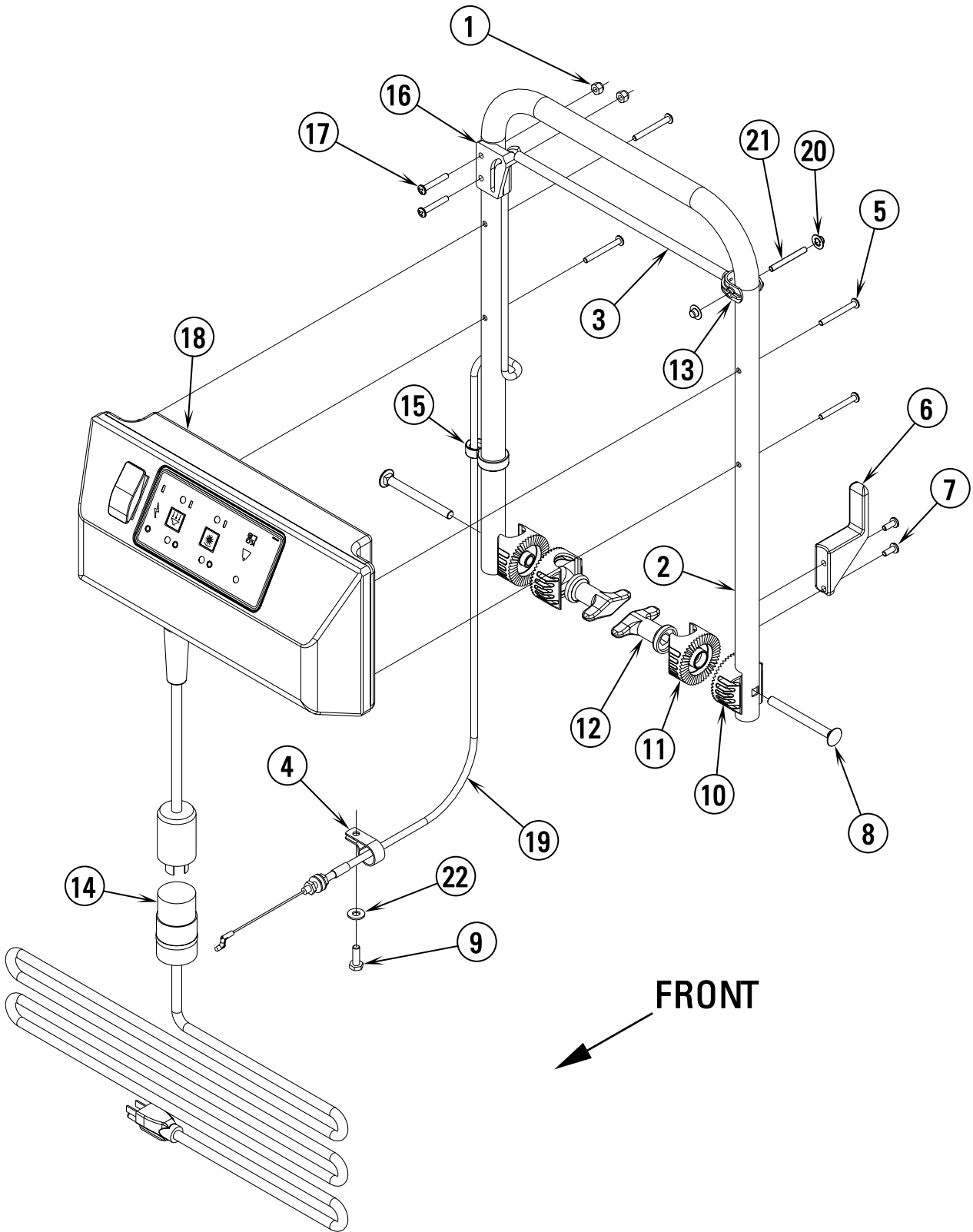

94-5

UPPER HANDLE ASSEMBLY

02-7

AquaClean™ 12/15/18**3**

Item	Ref. No.	Qty	Description
1	56001822	2	Nut, Acorn 10-24
2	56264142	1	Handle, Upper
3	56264147	1	Tube, Handle
4	56486112	1	P-Clamp
5	56002020	4	Scr, Pan Phil 10-24 x 1.75
6	56262518	1	Hook, Cord
7	56009029	2	Scr, Pan Phil HP5 10-24 x .50
8	56009138	2	Scr, Carriage 5/16-18 x 3.25
9	56002948	1	Scr, Hex Hd Loc 1/4-20 x .75
10	56264118	2	Ratchet
11	56264123	2	Ratchet
12	56370711	2	Nut, Thumb
13	56262655	1	Clevis
14	56262119	1	Cord Set 14/3 x 40' Blk 120V
15	56264374	1	Support, Cable
16	56262570	1	Support, Cable
17	56002824	2	Scr, Pan Phil 10-24 x 1.25
18	56264247	1	Console Assembly 120V - see pages 4-5
	56264250	1	Console Assembly 230V - see pages 4-5
19	56264146	1	Cable Assembly
20	56009132	2	Push Cap
21	56262193	1	Stud
22	56002098	1	Wsh, Flt SAE 1/4

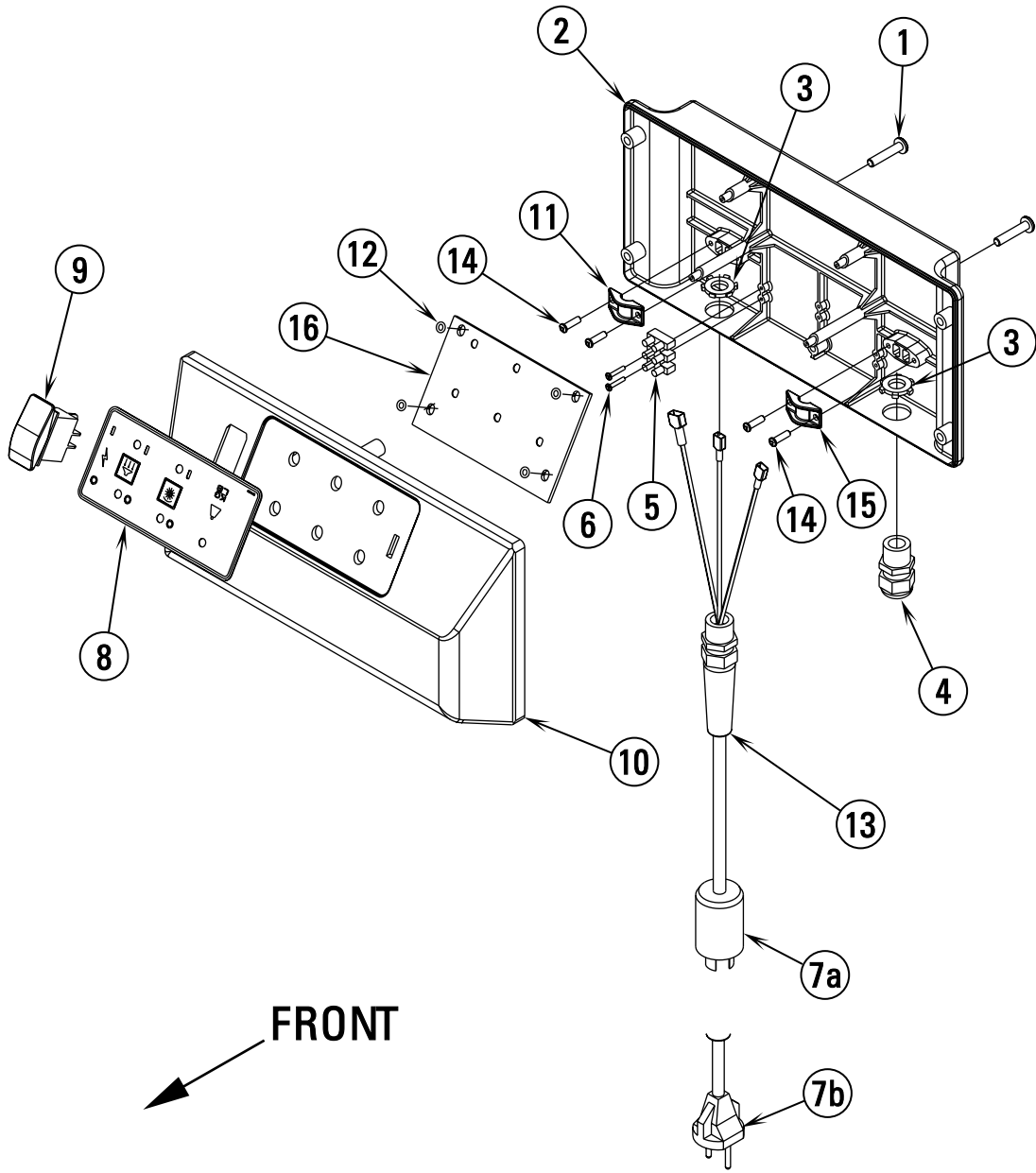

94-5

CONSOLE ASSEMBLY

02-7

AquaClean™ 12/15/18**5**

Item	Ref. No.	Qty	Description
	56264247	1	Console Assembly 120V
	56264250	1	Console Assembly 230V
1	56009181	2	Scr, Pan Phil Plastite #12 x 1.25
2	56264055	1	Console, Bottom
3	56009095	2	Nut, Conduit Lock
4	56323135	1	Strain Relief
5	56183523	1	Terminal Block 230V (double insulated)
	56183523	3	Terminal Block 230V (grounded) (120V before SN1090269)
6	56003092	2	Scr, Pan Phil Plastite 4-20 x .62 230V
7a	56264433	1	Cord Set 120V (after SN1090268)
	56264244	1	Cord Set 120V (before SN1090269)
7b	56262003	1	Power Cord 230V (double insulated)
	56301309	1	Power Cord 230V (grounded)
8	56264120	1	Switch, Membrane
9	56393312	1	Switch, Rocker
10	56264054	1	Console, Top
11	56262136	1	Clamp, Power Cord 230V (double insulated)
12	56257362	4	O-Ring
13	56323136	1	Strain Relief 230V
14	56002738	4	Scr, Pan Phil Plastite 8-15 x .62
15	56264119	2	Clamp, Power Cord (2 on 120V)
	56262185	1	Clamp, Power Cord (1 on double insulated 230V / 2 on grounded 230V)
16	56264330	1	Controller, 100/120V (used on 12" & 15" after SN1052727)
	56264258	1	Controller, 120V (used on 12" & 15" before SN1052728 and all 18's)
	56264264	1	Controller, 230V

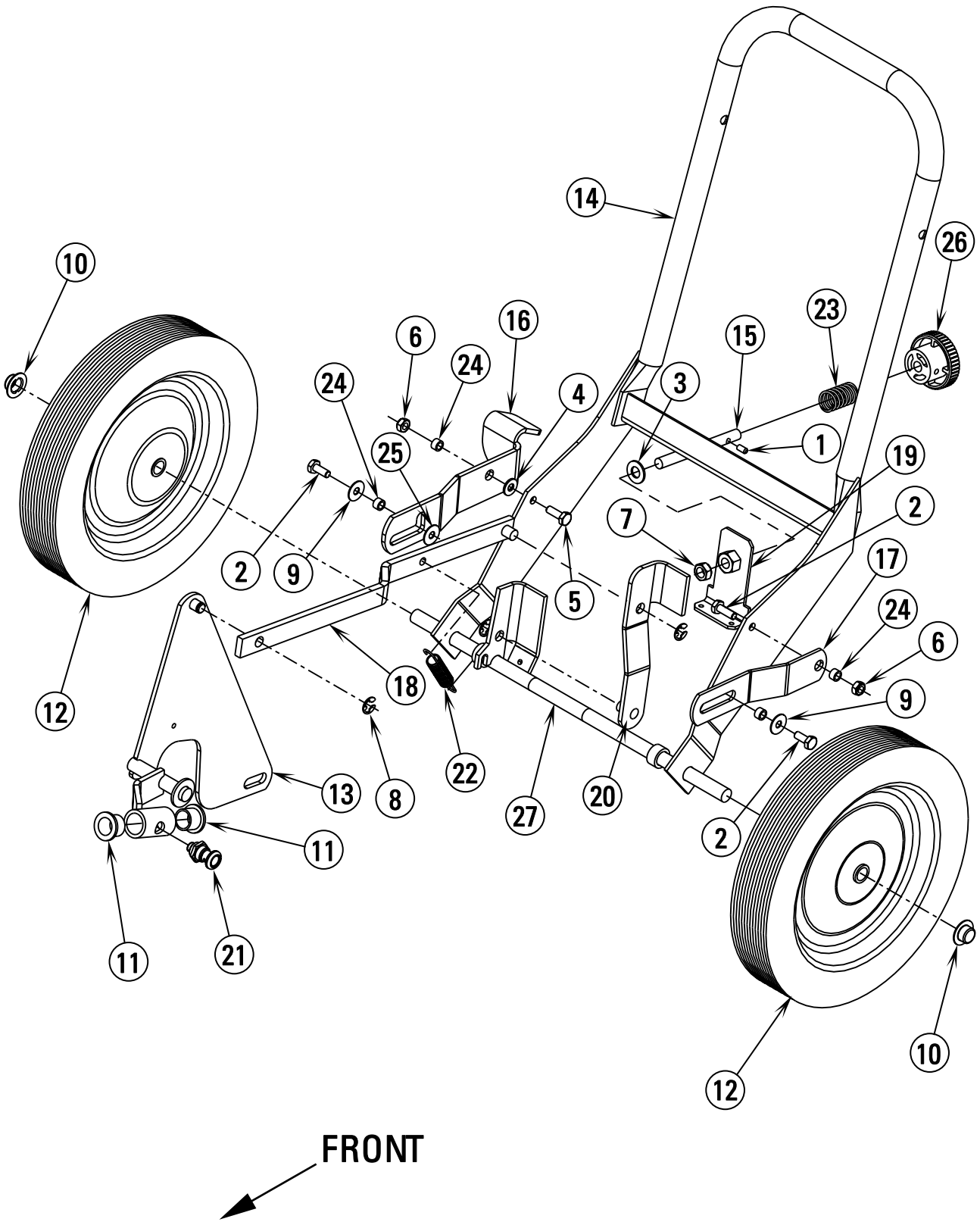

94-5

LOWER HANDLE ASSEMBLY

02-7

AquaClean™ 12/15/18**7**

Item	Ref. No.	Qty	Description
1	56003123	1	Scr, Soc Set Loc 10-24 x .38
2	56001836	3	Scr, Hex Hd 1/4-20 x .62
3	56002063	1	Wsh, Flt SAE 3/8
4	56002098	1	Wsh, Flt SAE 1/4
5	56002155	1	Scr, Hex Hd 1/4-20 x .75
6	56002840	2	Nut, Hex Nyl Loc-Thin 1/4-20
7	56002841	1	Nut, Hex Nyl Loc-Thin 3/8-16
8	56003262	3	Ring, Ret Ext Type E .38 Dia
9	56009025	2	Wsh, Flt .26 x .75 x .03
10	56009097	2	Nut, Push Cap 1/2
11	56171095	2	Bearing, Flange
12	56201774	2	Wheel
13	56264041	1	Lever Weld't
14	56264046	1	Axle Weld't
15	56264067	1	Screw, Adjusting
16	56264076	1	Latch
17	56264078	1	Plate, Handle Support
18	56264390	1	Linkage Weld't
19	56264443	1	Nut Plate Weldment
20	56264447	1	Lever Weldment
21	56365548	1	Lock Pin Assy
22	56370355	1	Spring
23	56377253	1	Compression Spring
24	56379298	4	Bushing
25	56388762	1	Wsh, Flt
26	56475480	1	Knob
27	56264396	1	Isolator (230V)

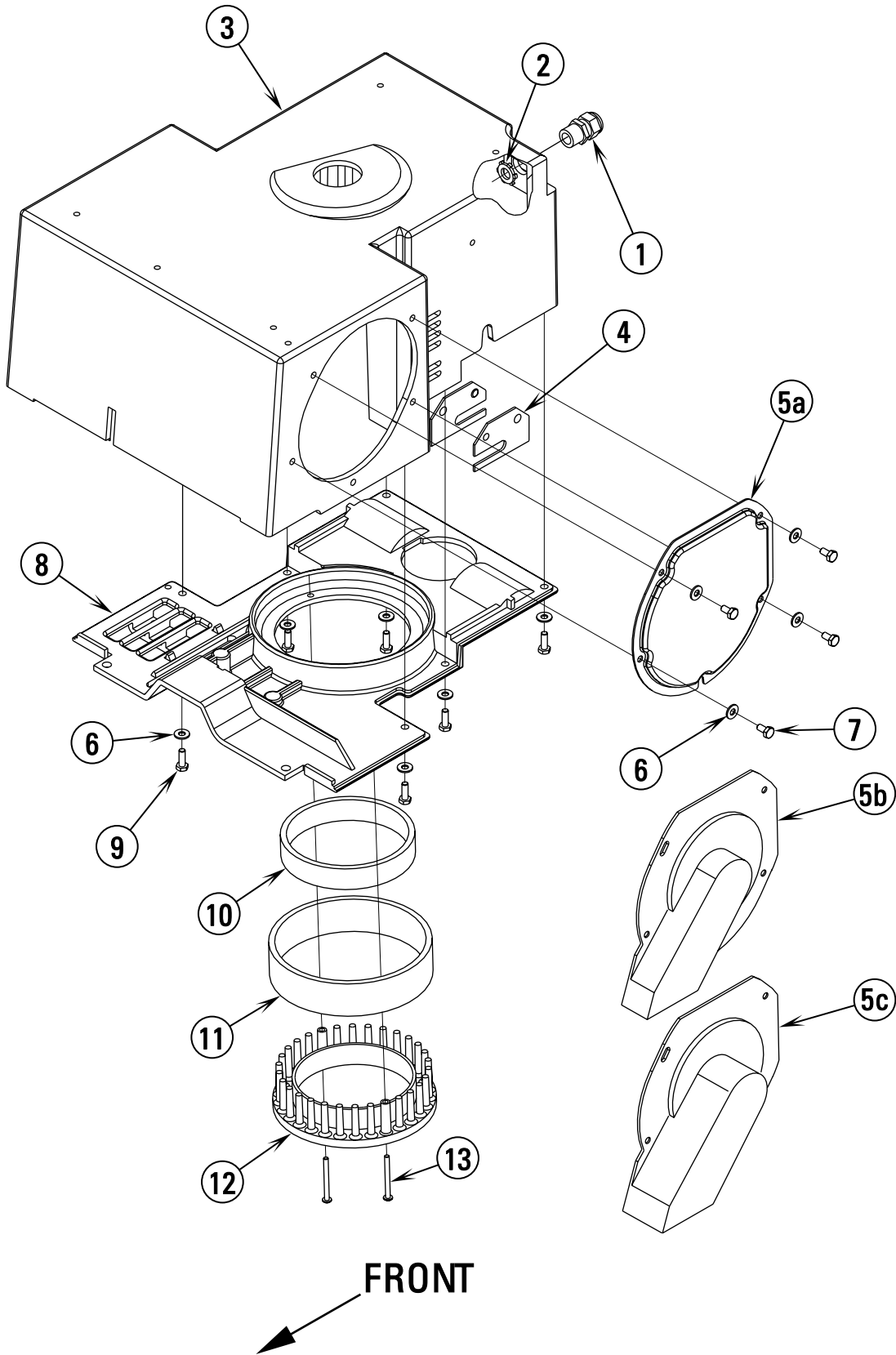

94-5

CHASSIS ASSEMBLY

02-7

AquaClean™ 12/15/18**9**

Item	Ref. No.	Qty	Description
1	56323135	1	Strain Relief
2	56009095	1	Nut, Conduit Lock 1/2-14
3	56264003	1	Chassis TSB 653
4	56264004	4	Plate
5a	56264072	1	Guard, Belt 12"
5b	56264051	1	Guard, Belt 15"
5c	56264073	1	Guard, Belt 18"
6	56002098	10	Wsh, Flt SAE 1/4 (Qty of 11 on AquaClean™ 15 and 18)
7	56001854	4	Scr, Hex Hd 1/4-20 x .5 (Qty of 5 on AquaClean™ 15 and 18)
8	56264002	1	Cover, Bottom
9	56002948	6	Scr, Hex Hd Loc 1/4-20 x .75
10	56264327	1	Foam, Accoustical
11	56264329	1	Filter, Cooling Air
12	56264328	1	Cap
13	56002171	2	Scr, Pan Phil 10-24 x 2.00

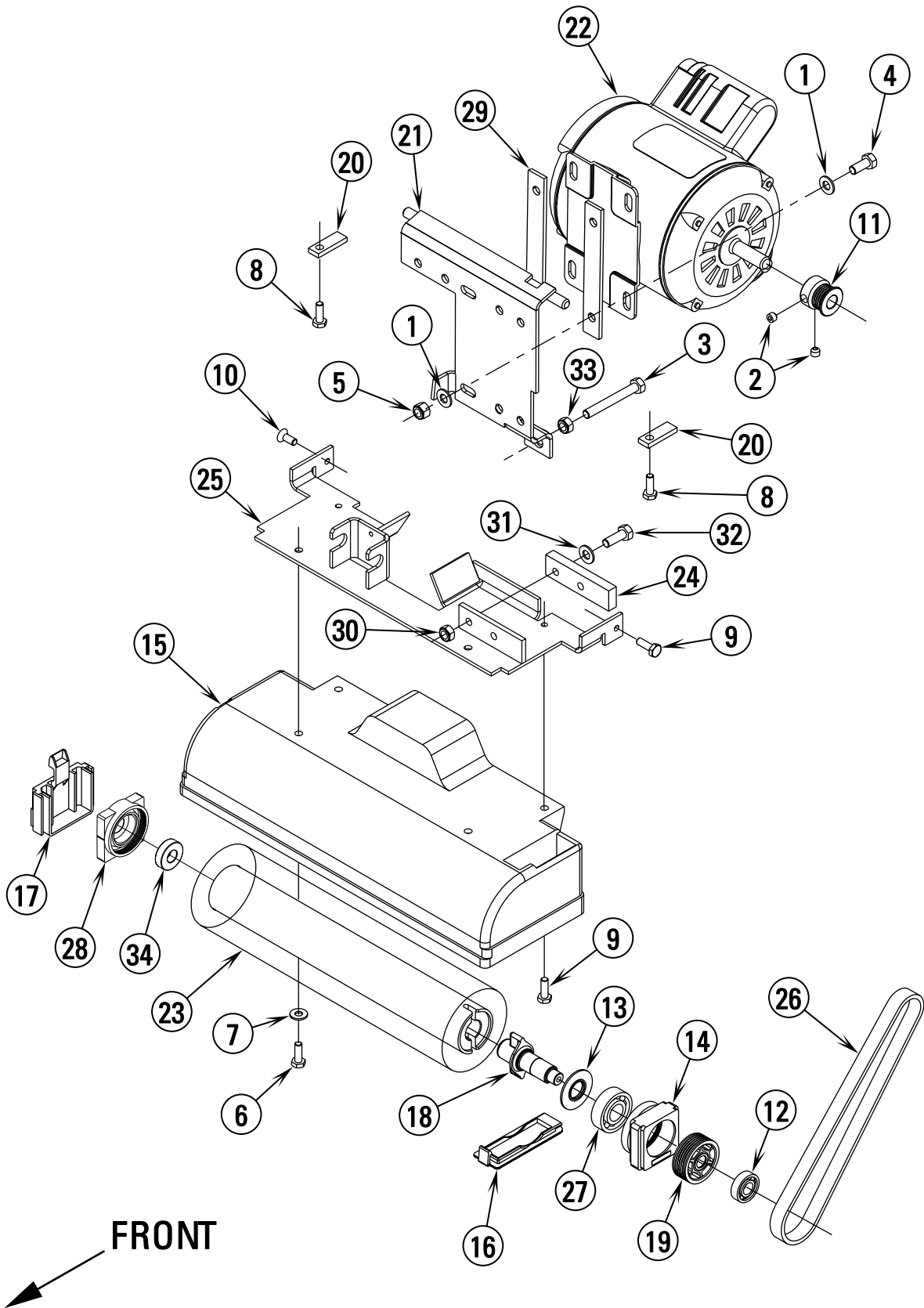

Item	Ref. No.	Qty	Description
1	56001939	6	Wsh, Flt SAE 5/16 (8 on 18")
2	56002086	2	Scr, Soc Set Loc 5/16-18 x .25
3	56002488	1	Scr, Hex Thd to Hd 5/16-18 x 2.50
4	56002667	3	Scr, Hex Hd 5/16-18 x .75 (4 on 18")
5	56002701	3	Nut, Hex Nyl Loc 5/16-18 (4 on 18")
6	56002807	2	Scr, Hex Hd SS 1/4-20 x .75
7	56002859	2	Wsh, Flt SAE SS 1/4
8	56003318	2	Scr, Hex Hd Loc 1/4-20 x 1.25
9	56009018	3	Scr, Hex Thd Form 1/4-20 x .75
10	56009137	1	Scr, Flt Phil Thd Form 1/4-20 x .62
11	56262558	1	Sheave, Poly-V
12	56262626	1	Bearing, Ball
13	56262645	1	Washer, Bearing
14	56262647	1	Bearing, Block (left side)
15	56264000	1	Brush Housing 12"
	56264025	1	Brush Housing 15"
	56264026	1	Brush Housing 18"
16	56264459	1	Cover
17	56264016	1	End Cap, Brush
18	56264049	1	Spindle, Drive
19	56264050	1	Sheave, Poly-V 6J17
20	56264070	2	Plate, Retainer
21	56264438	1	Motor Bracket Weld't
22	56238148	1	Motor 120V, 1/4 HP (12" & 15" before SN1052728)
	56264308	1	Motor 100/115V, 1/4 HP (12" & 15" after SN 1052727)
	56264299	1	Motor 115V, 1/3 HP 18"
	56264356	1	Motor 220-240V, 1/4 HP 12" & 15"
	56264300	1	Motor 220-240V, 1/3 HP 18"
23	56264357	1	Carpet Brush Assy 12" (includes #28 & 34) NOTE #1
	56264358	1	Carpet Brush Assy 15" (includes #28 & 34) NOTE #1
	56264359	1	Carpet Brush Assy 18" (includes #28 & 34) NOTE #1
24	56264394	1	Isolator 220-240V
25	56264395	1	Bracket Weld't
26	56327476	1	Belt, Poly-V 200J6
27	56372773	1	Bearing, Ball
28	56262648	1	Bearing, Block (right side)
29	56264378	2	Spacer 18"
30	56002708	2	Nut, Hex Nyl Loc 1/4-20 220-240V
31	56002098	2	Wsh, Flt SAE 1/4 220-240V
32	56002093	2	Scr, Hex Hd 1/4-20 x 1.00 220-240V
33	56001985	1	Nut, Hex Hvy 5/16-18
34	56262626	1	Bearing, Ball

NOTE #1: These are the standard carpet brush assemblies that come with the machines. For the optional hard floor brushes, please see page 34.

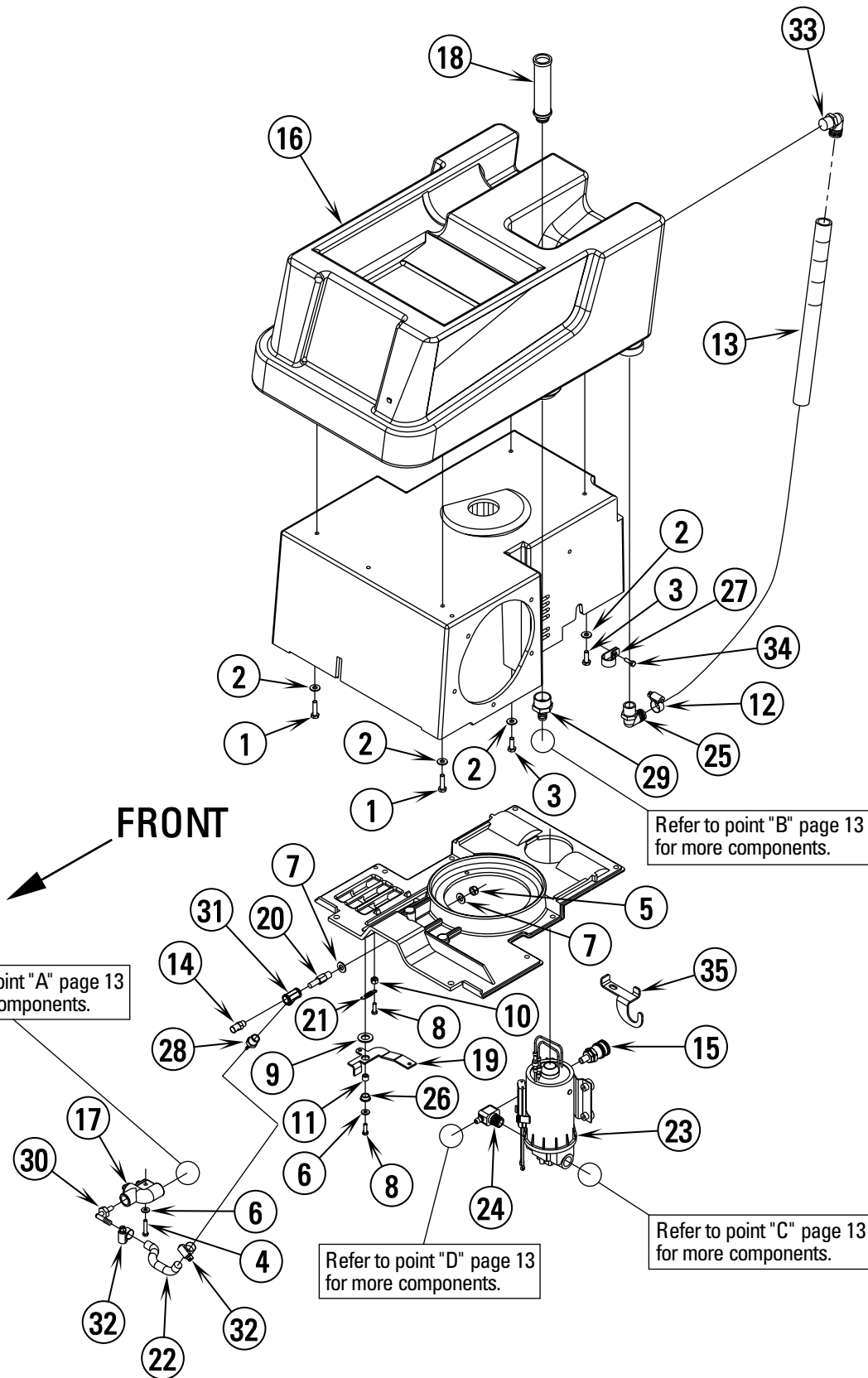

Item	Ref. No.	Qty	Description	Item	Ref. No.	Qty	Description
1	56002093	2	Scr, Hex Hd 1/4-20 x 1.00	17	56262596	1	Valve
2	56002098	4	Wsh, Flt SAE 1/4	18	56264137	1	Screen
3	56002155	2	Scr, Hex Hd 1/4-20 x .75	19	56264444	1	Lever, Valve
4	56002837	1	Scr, Hex Hd SS 10-24 x 1.00	20	56264216	1	Adapter, Nozzle, 1/8
5	56002851	1	Nut, Hex Nyl Loc-Thin SS 5/16-18	21	56264257	1	Spring, Extension
6	56002916	2	Wsh, Flt SAE SS #10	22	56264260	1	Hose
7	56002938	2	Wsh, Flt SAE SS 5/16	23	56264305	1	Pump 115V NOTE #2
8	56003297	2	Scr, Hex Hd SS 10-24 x .62		56264306	1	Pump 230V NOTE #2
9	56009003	1	Washer, Flt .51 x .93 x .07	24	56264382	1	Adapter, Barbed TSBUS2002-819
10	56009009	1	Nut, Hex Machine	25	56456802	1	Barb, 90° Elbow 35/64 x 3/4 NPT
11	56200123	1	Bushing	26	56324505	1	Bearing, Flange
12	56112771	1	Clamp, Hose	27	56328064	1	P Clamp
13	56264462	1	Hose, Solution Gauge	28	56369594	1	Barb, Adapter 1/4 x 1/8 NPT
14	56249334	1	Nozzle	29	56262190	1	Barb, Adapter 1/2 x 3/4 NPT
15	56249568	1	Coupling	30	56470138	1	Barb, 90° Elbow 19/64 x 1/4 NPT
16	56264083	1	Tank, Solution 12" NOTE #1	31	56752020	1	Tee 1/8
	56264007	1	Tank, Solution 15" NOTE #1	32	56756364	2	Clamp, Hose SAE #4
	56264081	1	Tank, Solution 18" NOTE #1	33	56264442	1	Barb, Elbow 35/64 x 3/8 NPT
				34	56009135	1	Scr, Hex Thd Form 10-24 x .62
				35	56264465	1	Bracket, Support TSBUS2002-819

NOTE #1: This Solution Tank is shown without the flow diverter plumbing necessary for hard floor cleaning. Please see pages 14-15 for all flow diverter parts. These parts now come standard on these models.

NOTE #2: The repair kits shown below are available for both pumps listed in item 23.

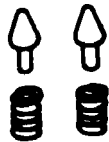

By-Pass Kit: PN 56264436

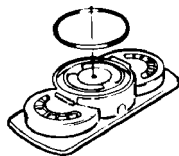

Check Valve Kit: PN 56264435

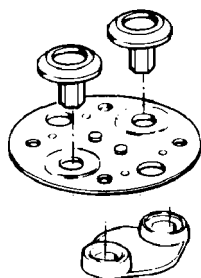

Diaphragm Kit: PN 56249834

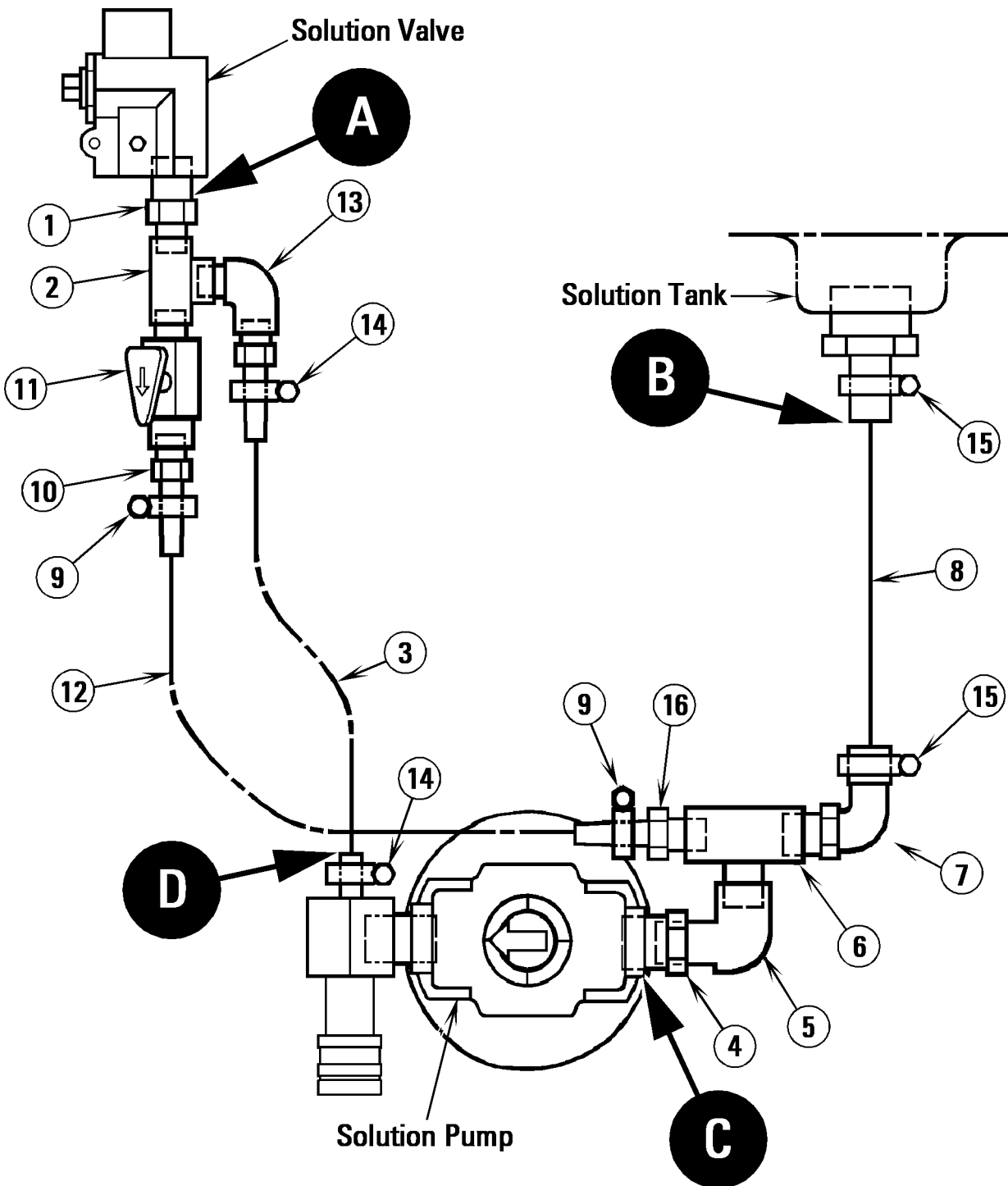

Item	Ref. No.	Qty	Description
	56264347	1	Flow Diverter Assy, 12" (#1-13)
	56264348	1	Flow Diverter Assy, 15" (#1-13)
	56264331	1	Flow Diverter Assy, 18" (#1-13)
1	56900044	1	Nipple, Reducing 1/4 x 1/8
2	56752020	1	Tee, 1/8 x 1/8 x 1/8
3	56264301	1	Hose, 1/4 Braided
4	56750363	1	Bushing, Reducing 1/4 x 3/8
5	56369632	1	Elbow, Street 1/4 x 1/4
6	56372506	1	Tee, Branch 1/4 x 1/4 x 1/4
7	56263809	1	Barb, Elbow 1/4 x 1/2
8	56264318	1	Hose, 1/2 Spiral
9	56756364	2	Clamp, Hose
10	56264351	1	Barb, .25 x .14 12"
	56264352	1	Barb, .25 x .12 15"
	56104299	1	Barb, .38 x .12 18"
11	56264286	1	Valve
12	56264346	1	Hose, .25 x 10.00 12" & 15"
	56264345	1	Hose, .38 x 10.00 18"
13	56755726	1	Barb, 1/4 x 1/8 x 90BR
14	56756364	2	Clamp, Hose SAE #4
15	56219932	2	Clamp, Hose SAE #6
16	56155640	1	Barb, .25 x .38 18"

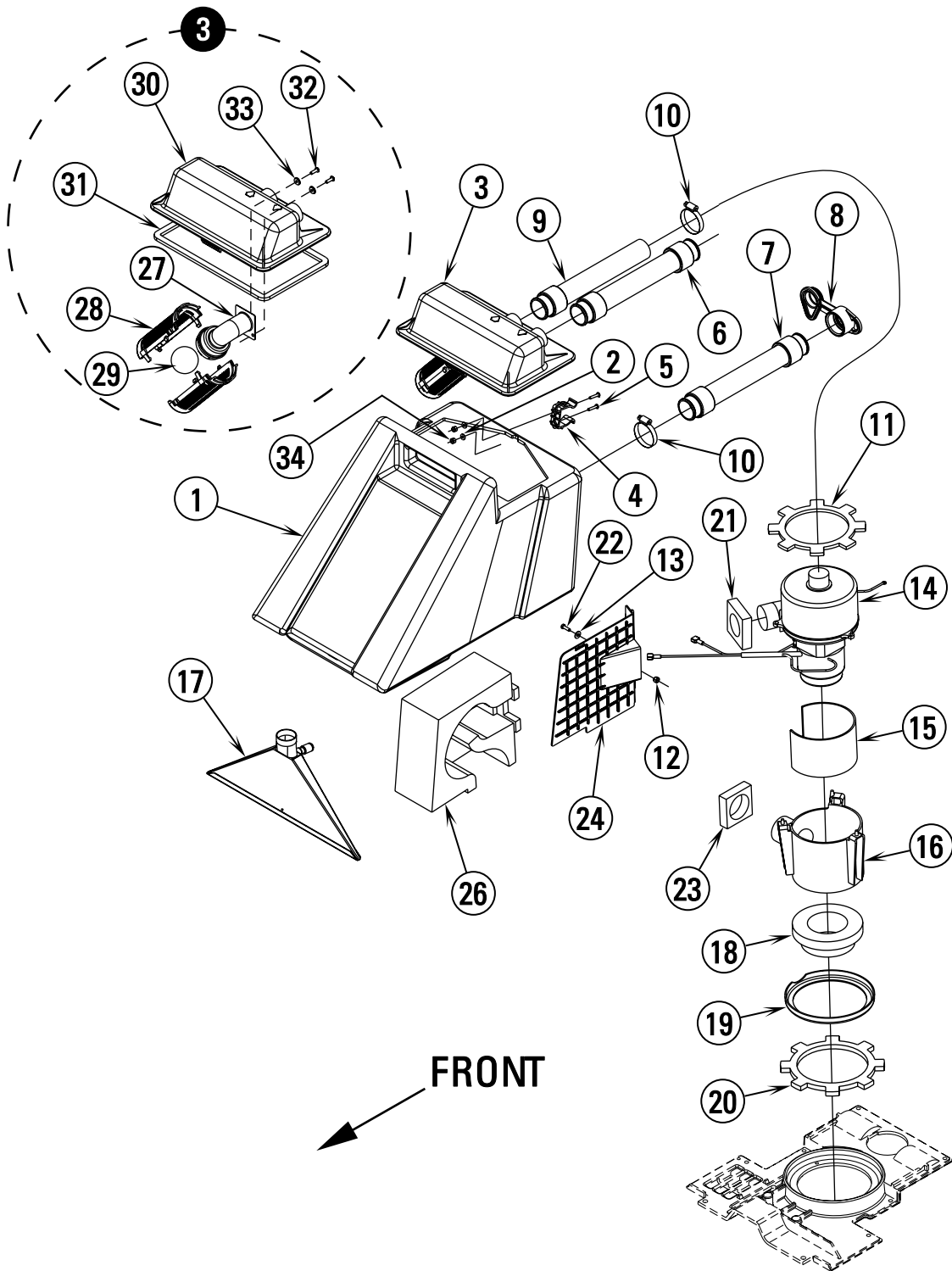

Item	Ref. No.	Qty	Description
1	56264087	1	Tank, Recovery 4 Gallon 12"
	56264009	1	Tank, Recovery 6 Gallon 15"
	56264085	1	Tank, Recovery 8 Gallon 18"
2	56002875	2	Wsh, Flt SAE SS #8
3	56324045	1	Cover Assembly TSB 636
4	56392171	1	Clamp
5	56009186	2	Scr, Pan Phil SS 8-32 x .88
6	56392170	1	Recovery Hose Assembly
7	56262143	1	Drain Hose Assembly
8	56393772	1	Plug, Hose
9	56262147	1	Vacuum Hose Assembly
10	56329145	2	Hose Clamp
11	56264103	1	Gasket, Vacuum Motor
12	56002836	1	Nut, Hex Nyl Loc SS 10-24
13	56002053	1	Wsh, Flt SAE #10
14	56264285	1	Vacuum Motor Assembly 120V TSB 653 / TSBUS2002-826
	56262007	1	Vacuum Motor Assembly 230V (double insulated) TSB 653 / TSBUS2002-826
	56264304	1	Vacuum Motor Assembly 230V (grounded) TSB 653 / TSBUS2002-826
15	56264233	1	Foam, Accoustical
16	56264283	1	Housing, Vac Motor TSB 653 / TSBUS2002-826
17	56264088	1	Shoe Weldment 12"
	56264117	1	Shoe Weldment 15"
	56264090	1	Shoe Weldment 18"
18	56264343	1	Ring Assembly
19	56264079	1	Ring, Vac Motor
20	56264105	1	Gasket, Vacuum Motor
21	56264116	1	Gasket, Vacuum Outlet
22	56009135	1	Scr, Hex Thd Form 10-24 x .62
23	56264114	1	Gasket, Vacuum
24	56264282	1	Wall, Muffler
25			Intentionally Omitted
26	56264450	1	Muffler
27	56324298	1	Elbow, Float
28	56324497	2	Cage, Float
29	56391690	1	Ball, Float
30	56324046	1	Cover, Tank
31	56262576	1	Gasket
32	56003633	2	Scr, Pan Phil SS Type B 10-16 x .50
33	56209261	2	Washer, Sealing 9/16
34	56002877	2	Nut, Hex Nyl Loc SS 8-32

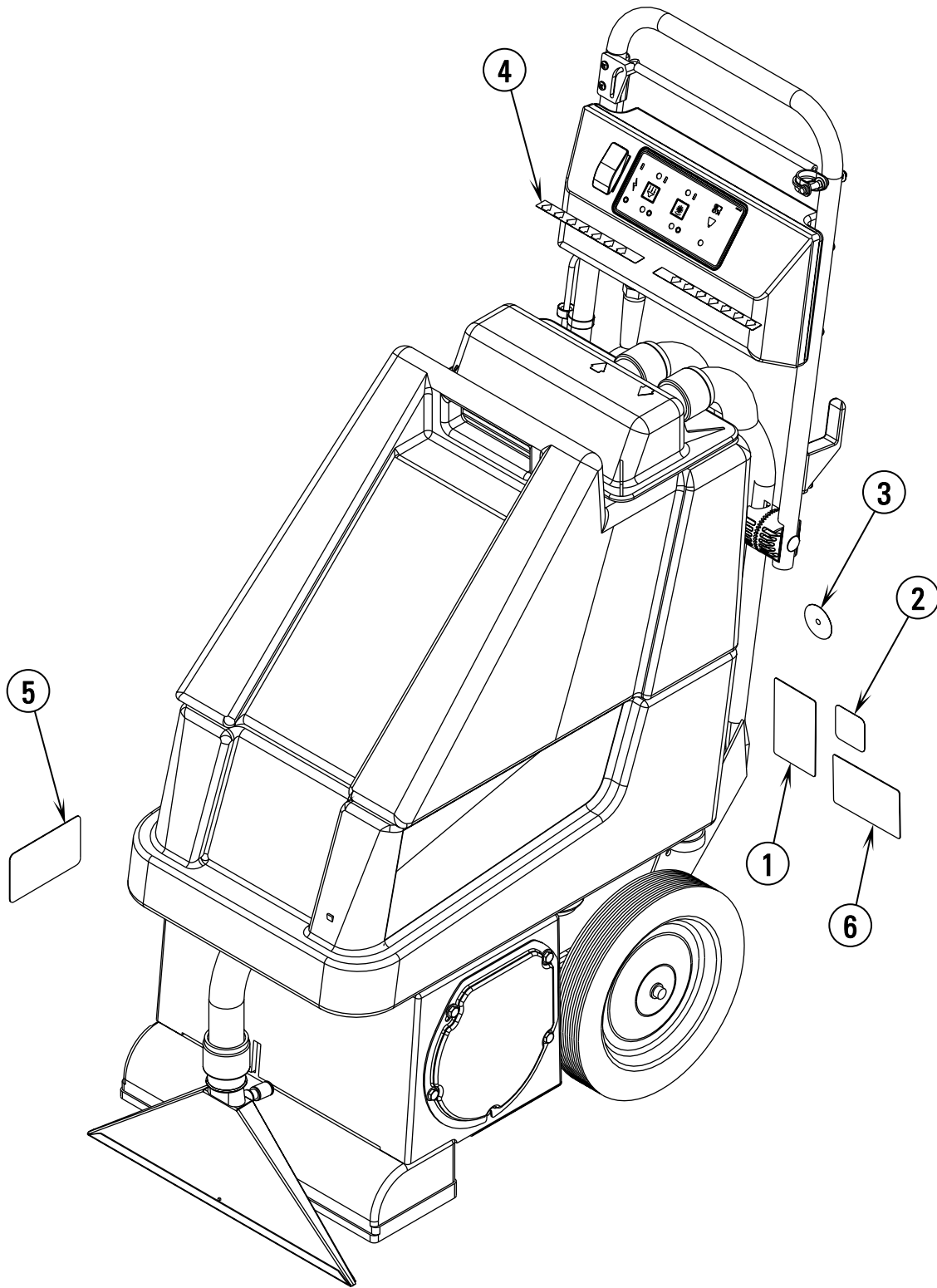

94-5

DECAL SYSTEM

02-7

AquaClean™ 12/15/18**19**

Item	Ref. No.	Qty	Description
1	56014781	1	Decal, Warning (15" & 18")
2	56015638	1	Decal, Pressure
3	56015639	1	Decal, Brush Pressure
4	56015655	2	Decal, Direction
5	56015678	1	Decal, Flow Diverter
6	56016003	1	Decal, Wear Items (12")
	56016012	1	Decal, Wear Items (15")
	56016013	1	Decal, Wear Items (18")

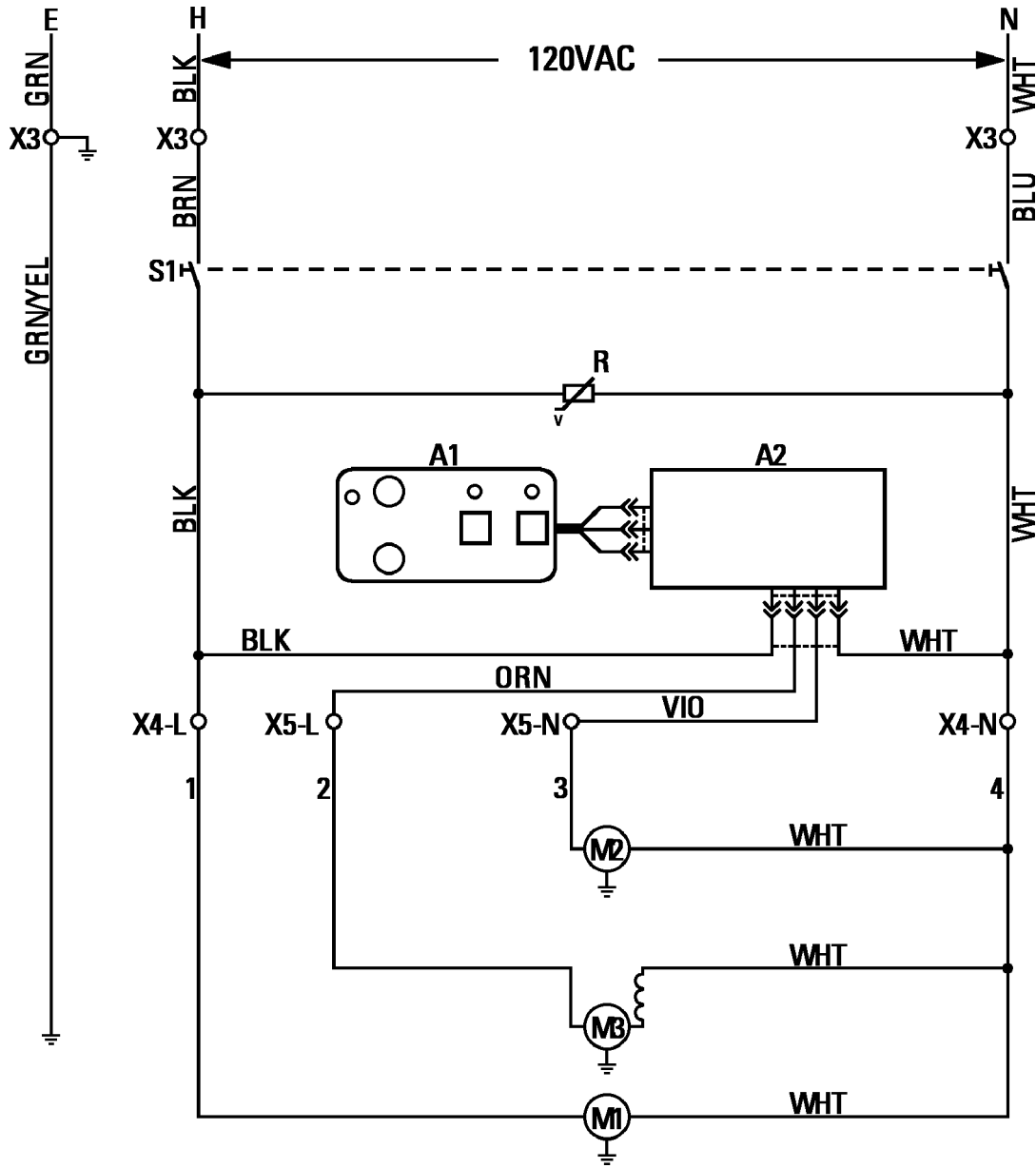

A1	56264120	Membrane Switch Pad	M3	56264285	Vacuum Motor TSB 653 / TSBUS2002-826
A2	56264258	Controller PCB (120V) (used on 12" & 15" before SN 1052728/ and all 18")	R	56264324	MOV
	56264330	Controller (100/120V) (used on 12" & 15" after SN 1052727)	S1	56393312	Main Switch
M1	56264305	Pump Motor	X3	56185523	Terminal Block
M2	56264308	Brush Motor 1/4 H.P. (100/120V-12" & 15") (after SN 1052727)	X4	56185523	Terminal Block
	56238148	Brush Motor 1/4 H.P. (120V-12" & 15") (before SN 1052728)	X5	56185523	Terminal Block
	56264299	Brush Motor 1/3 H.P. (120V-18")	X6		Adjustment Knob Plate Grounding
			X7		Axle Assembly Grounding
			X8		Belt Adjuster Plate Grounding
			X9		Bracket Weldment Grounding
			X10		Pick-Up Lever Grounding
			X11		Vac Housing Grounding

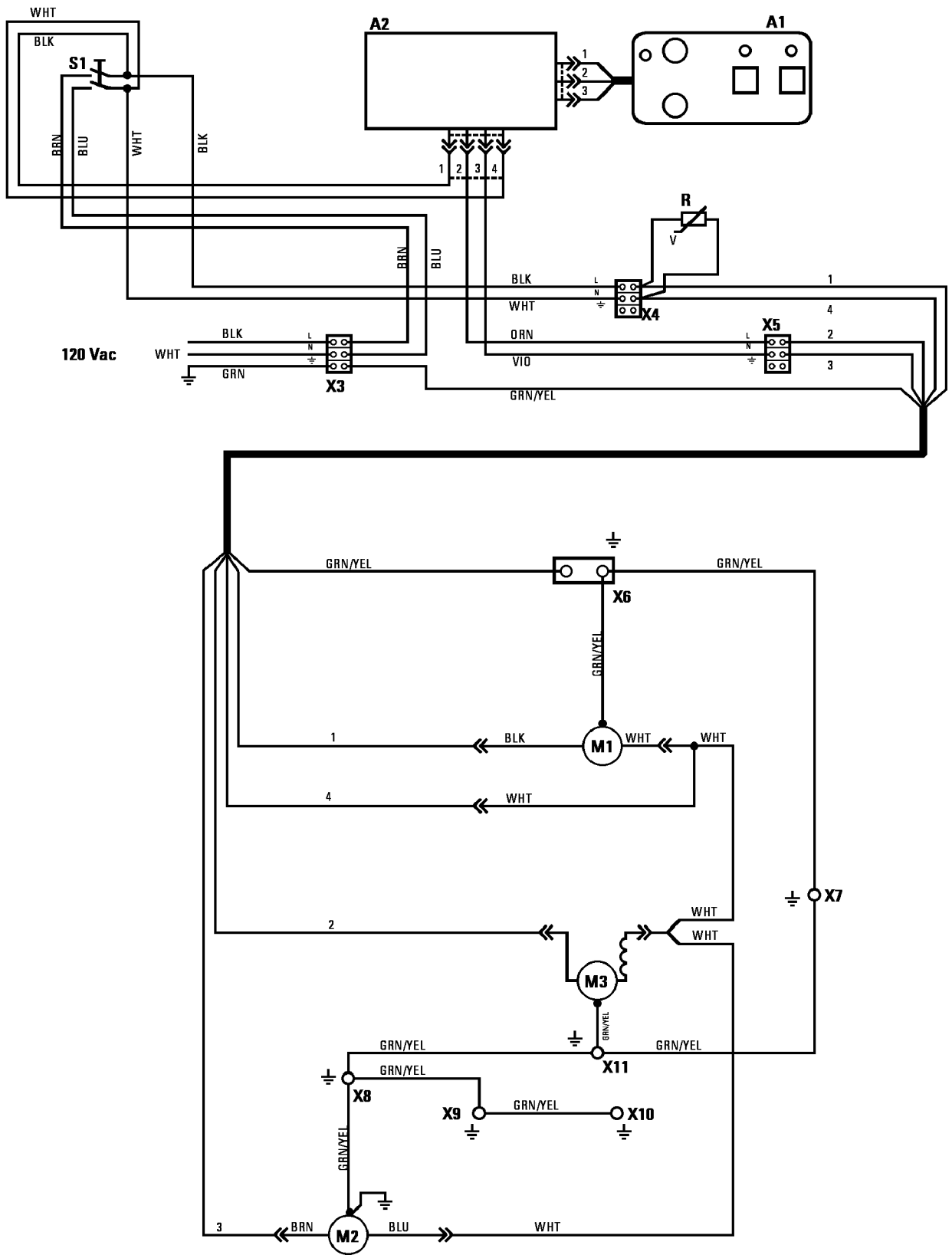

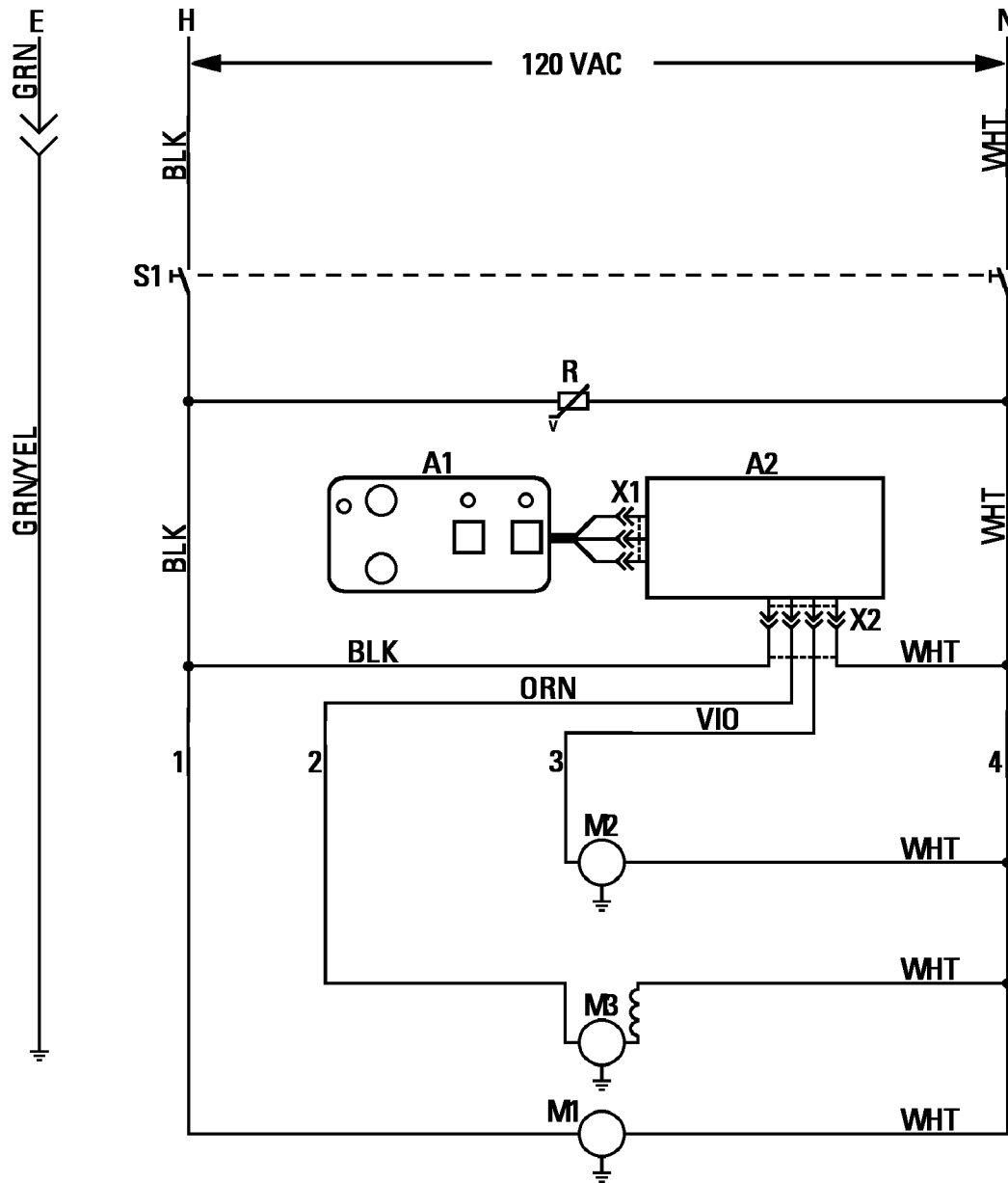

- | | | |
|----|----------|--|
| A1 | 56264120 | Membrane Switch Pad |
| A2 | 56264258 | Controller PCB (120V)
(used on 12" & 15" before SN 1052728/
and all 18") |
| | 56264330 | Controller (100/120V)
(used on 12" & 15" after SN 1052727) |
| M1 | 56264305 | Pump Motor |
| M2 | 56264308 | Brush Motor 1/4 H.P. (100/120V-12" & 15")
(after SN 1052727) |
| | 56238148 | Brush Motor 1/4 H.P. (120V-12" & 15")
(before SN 1052728) |
| | 56264299 | Brush Motor 1/3 H.P. (120V-18") |
| M3 | 56264285 | Vacuum Motor TSB 653 / TSBUS2002-826 |

- | | | |
|----|----------|---------------------------------|
| R | 56264324 | MOV |
| S1 | 56393312 | Main Switch |
| X1 | | Membrane Switch Connector |
| X2 | | Controller Connector |
| X3 | | Adjustment Knob Plate Grounding |
| X4 | | Axle Assembly Grounding |
| X5 | | Belt Adjuster Plate Grounding |
| X6 | | Bracket Weldment Grounding |
| X7 | | Pick-Up Lever Grounding |

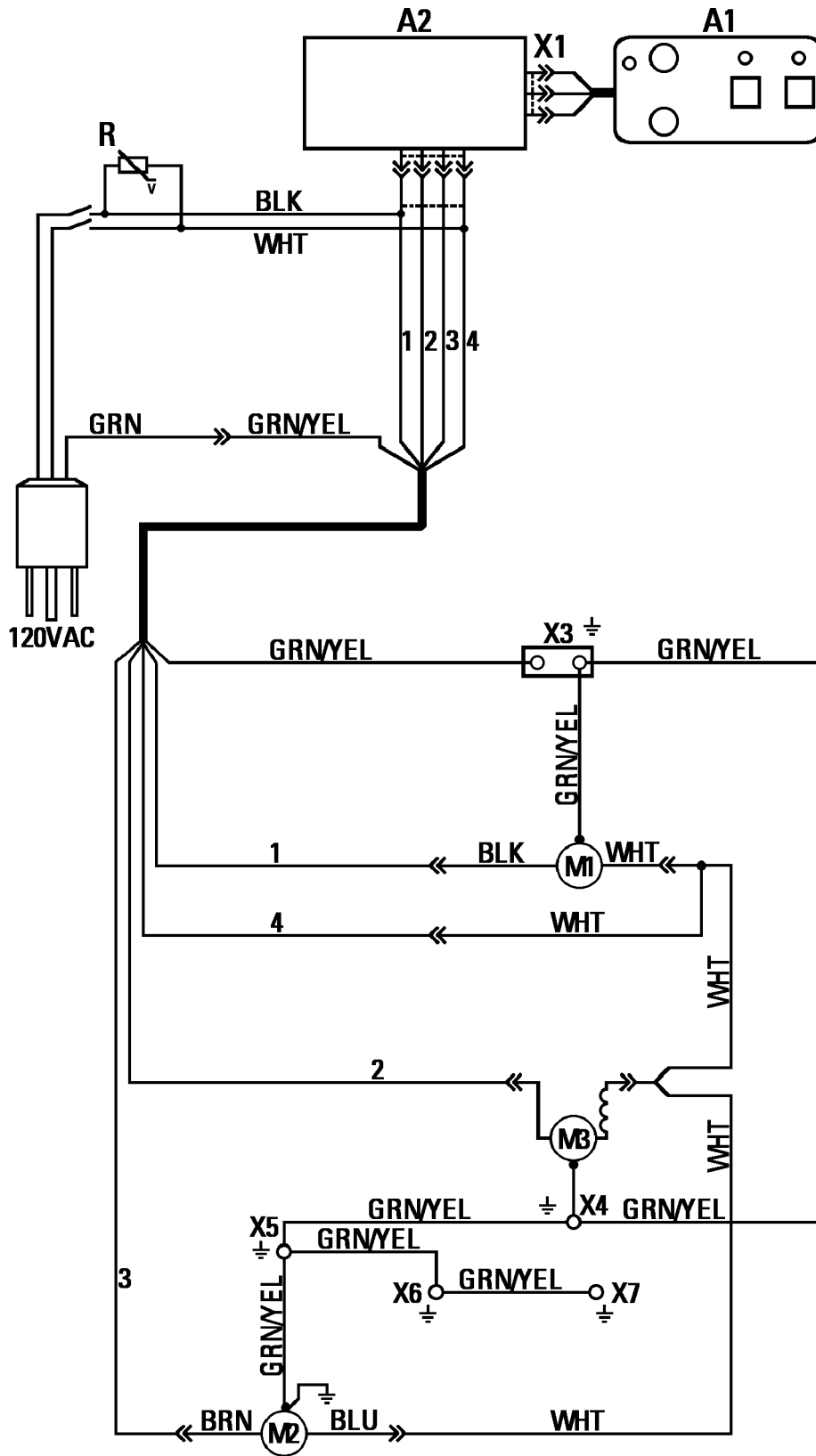

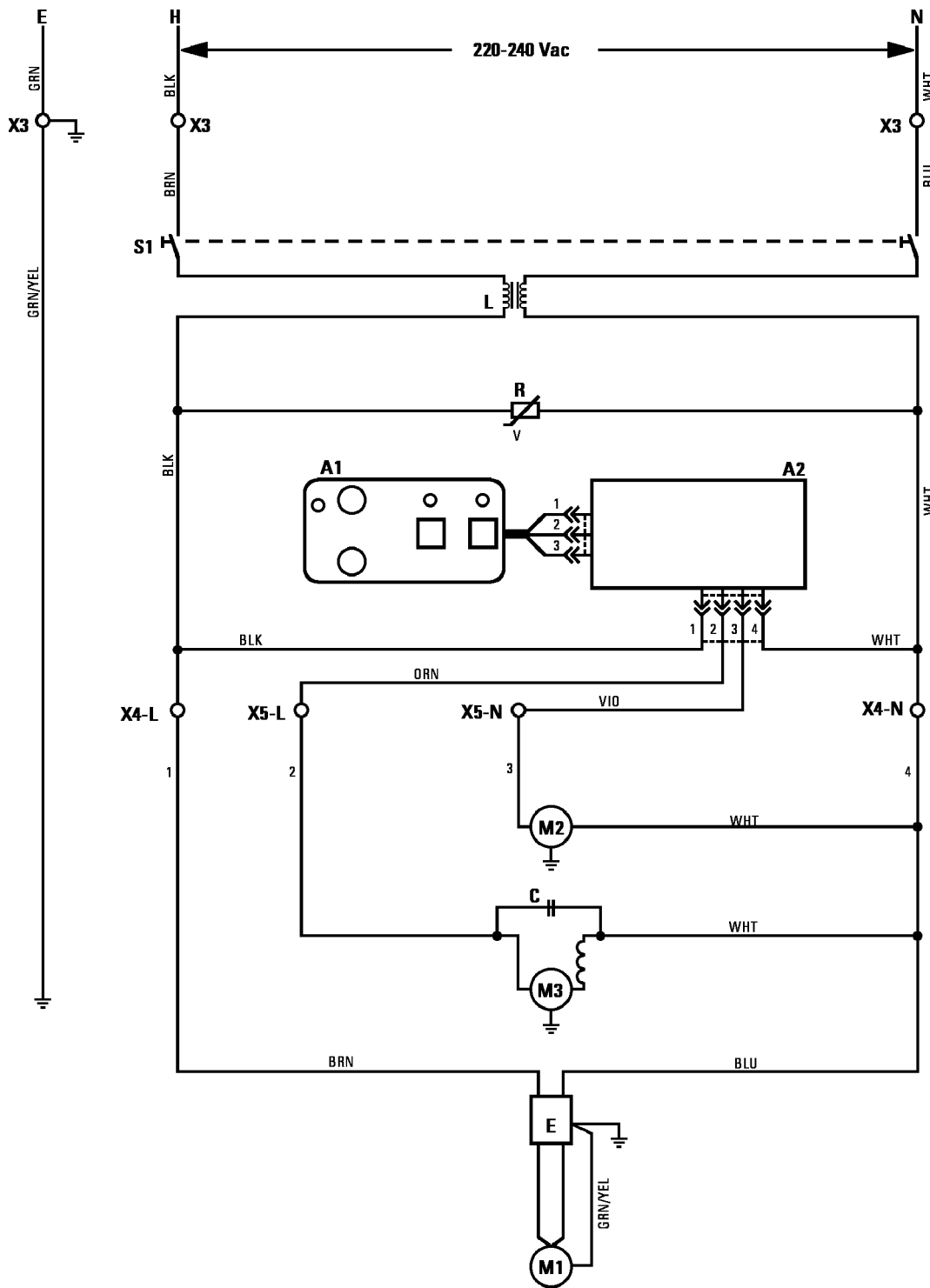

- | | | |
|----|----------|---|
| A1 | 56264120 | Membrane Switch Pad |
| A2 | 56264264 | Controller PCB |
| C | 56264350 | Capacitor |
| E | | RFI Filter (part of Solution Pump) |
| L | 56264349 | Choke Coil |
| M1 | 56264306 | Pump Motor |
| M2 | 56264300 | Brush Motor |
| M3 | 56264304 | Vacuum Motor TSB 653 / TSBUS2002-826 |
| R | 56264324 | MOV |

- | | | |
|-----|----------|---------------------------------|
| S1 | 56393312 | Main Switch |
| X3 | 56183523 | Terminal Block |
| X4 | 56183523 | Terminal Block |
| X5 | 56183523 | Terminal Block |
| X6 | | Adjustment Knob Plate Grounding |
| X7 | | Axle Assembly Grounding |
| X8 | | Belt Adjuster Plate Grounding |
| X9 | | Bracket Weldment Grounding |
| X10 | | Pick-Up Lever Grounding |
| X11 | | Vac Housing Grounding |

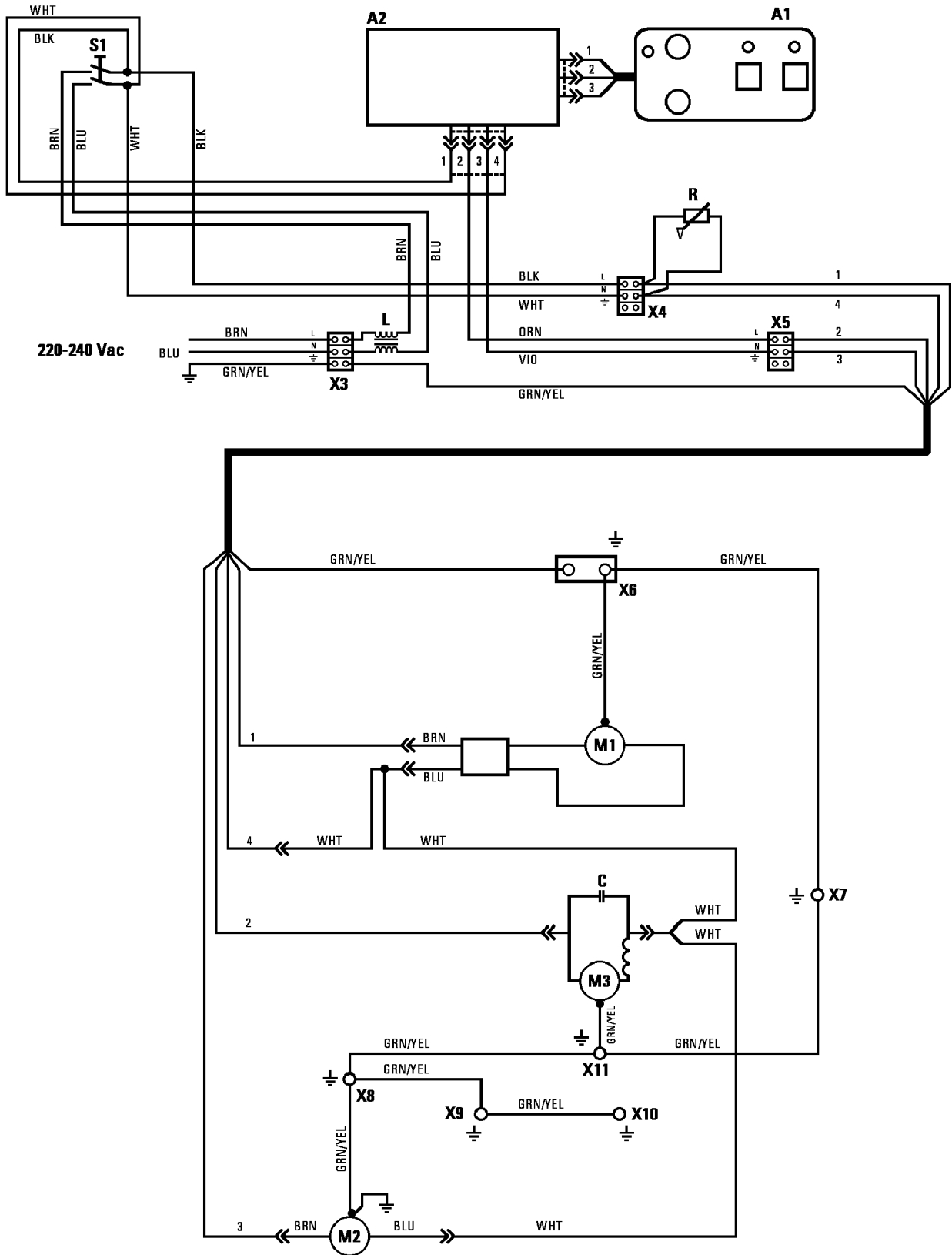

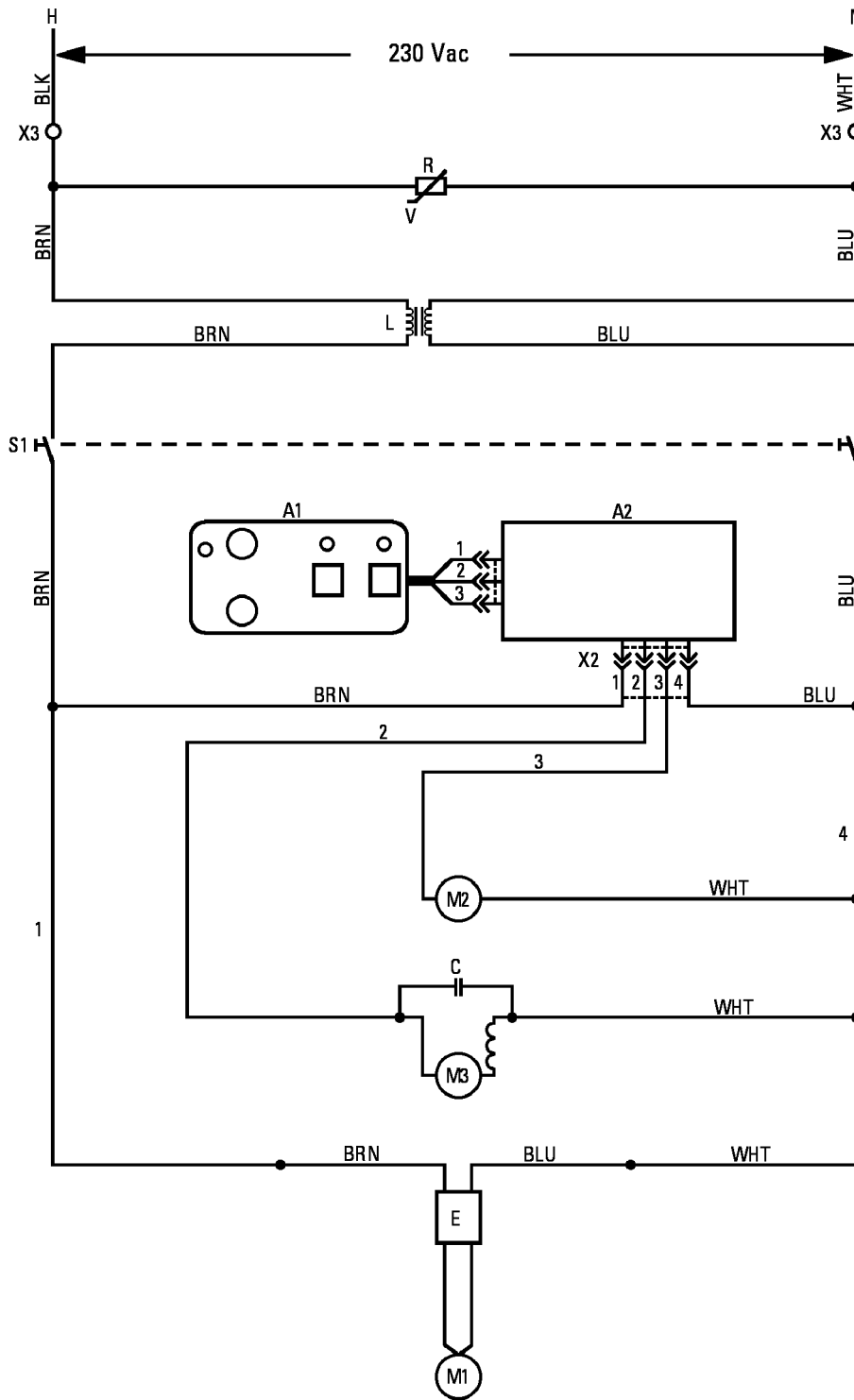

A1	56264120	1	Membrane Switch Pad	M3	56262007	1	Vacuum Motor TSB 653 / TSBUS2002-826
A2	56264264	1	Controller PCB	R	56264342	1	Varistor
C	56264350	1	Capacitor	S1	56393312	1	Main Switch
E		1	RFI Filter (part of solution pump)	X2		1	Controller PCB Connector
L	56264349	1	Choke Coil	X3	56183523	1	Terminal Block
M1	56264306	1	Solution Pump				
M2	56264356	1	Motor 220-240V, 1/4 HP 12" & 15"				
	56264300	1	Motor 220-240V, 1/3 HP 18"				

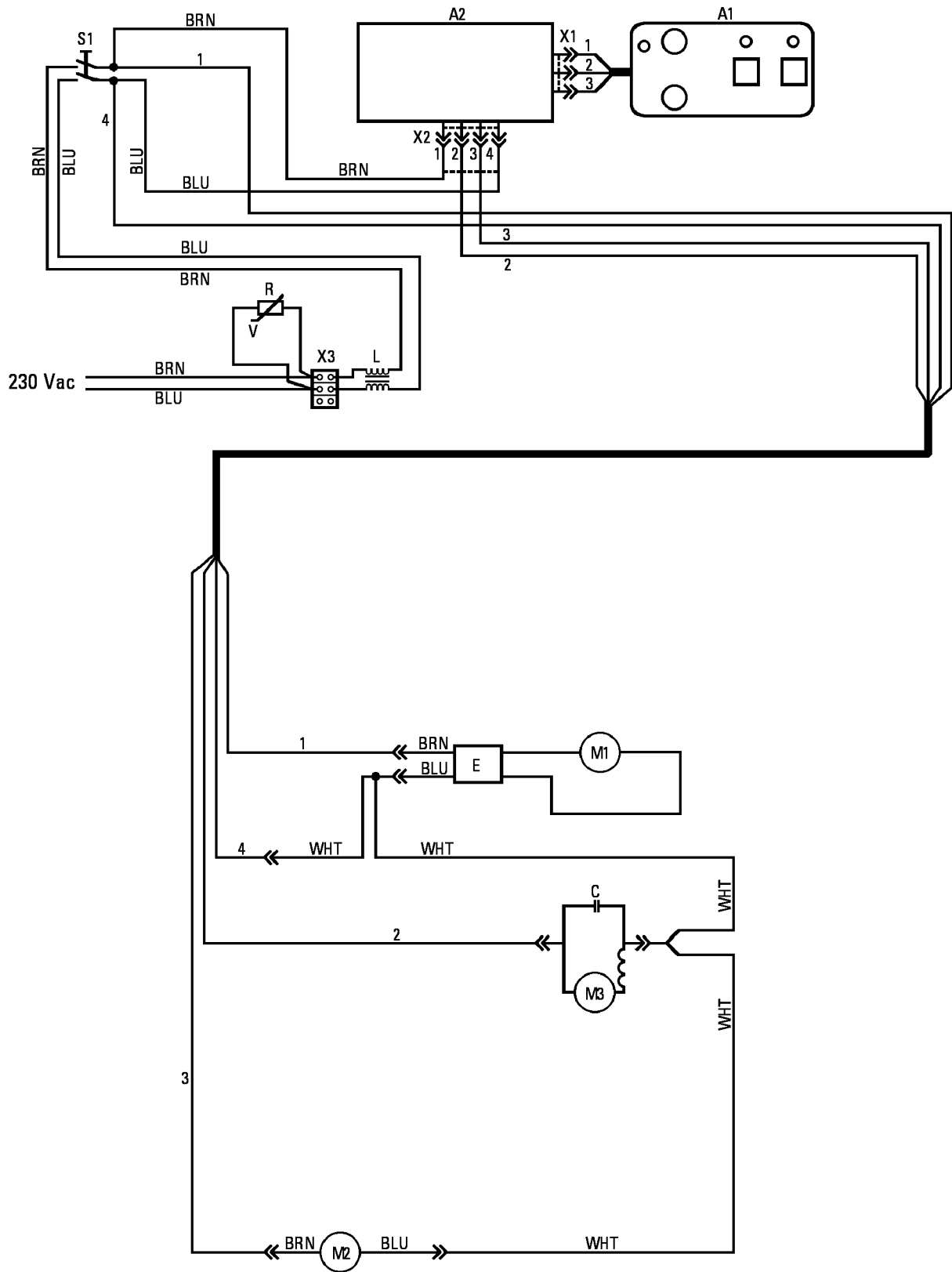

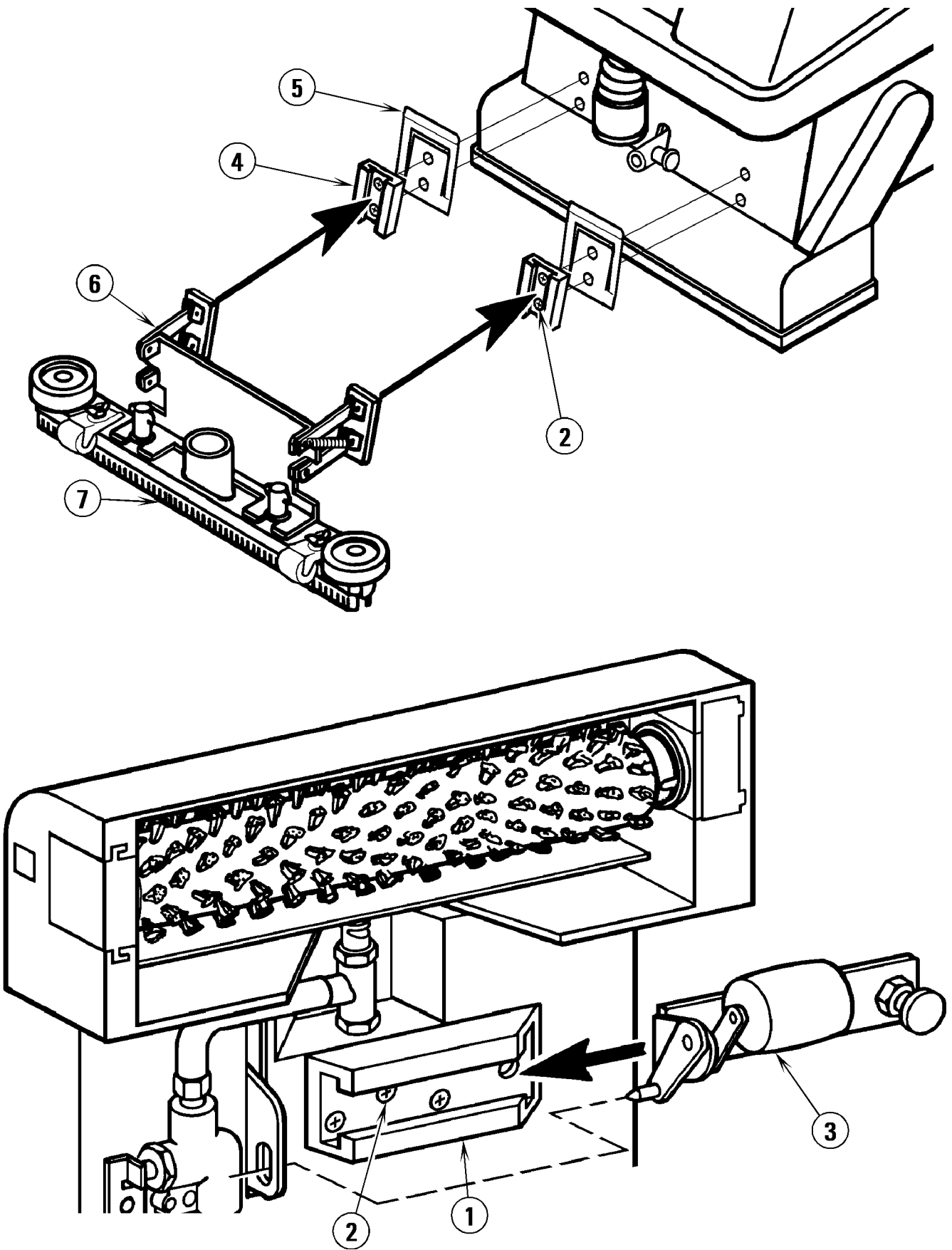

Item	Ref. No.	Qty	Description
	56264369	1	Hard Floor Kit 12"
	56262164	1	Hard Floor Kit 15"
	56264371	1	Hard Floor Kit 18"
*	56040537	1	Instruction Sheet
1	56264183	1	Channel
2	56003096	7	Scr, Fl Hd Phi 1/4-20 x 3/8
3	56264398	1	Carriage Assembly
4	56264201	2	Channel
5	56264342	2	Clip (current part looks different than pictured here)
6	56264344	1	Squeegee Mount Assembly (pages 30-31)
**	56481699	4	Spring
7	56264130	1	Squeegee Ass'y 12" (Kit 56264369)
**	56264159	1	Squeegee Cartridge only 12"
**	56105577	2	Squeegee Blade only 12"
	56264165	1	Squeegee Ass'y 15" (Kit 56262164)
**	56264172	1	Squeegee Cartridge only 15"
**	56105578	2	Squeegee Blade only 15"
	56264340	1	Squeegee Ass'y 18" (Kit 56264371)
**	56264338	1	Squeegee Cartridge only 18"
**	56105506	2	Squeegee Blade only 18"
**	56387376	2	Squeegee Roller Assembly

* = not shown

** = replacement part

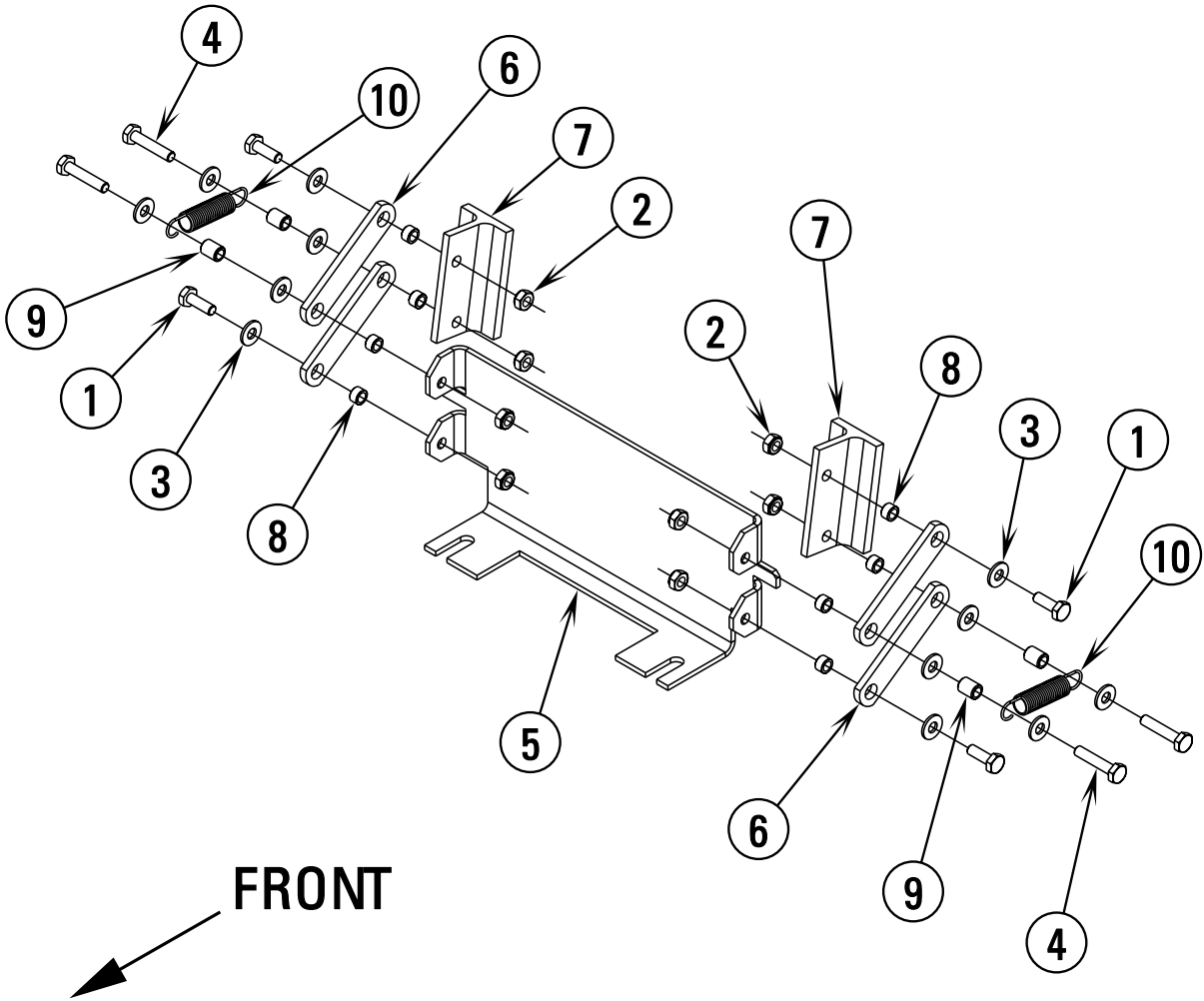

94-5

SQUEEGEE MOUNT ASSEMBLY

02-7

AquaClean™ 12/15/18**31**

Item	Ref. No.	Qty	Description
	56264344	1	Squeegee Mount Assembly (#1-10)
1	56002807	4	Scr, Hex Hd SS 1/4-20 x .75
2	56002850	8	Nut, Hex Nyl Loc-Thin SS 1/4-20
3	56002859	12	Wsh, Flt SAE SS 1/4
4	56002897	4	Scr, Hex Hd SS 1/4-20 x 1.25
5	56264125	1	Mount, Squeegee
6	56264204	4	Arm
7	56264273	2	Bracket
8	56379298	8	Bushing
9	56475411	4	Bushing
10	56481699	2	Spring

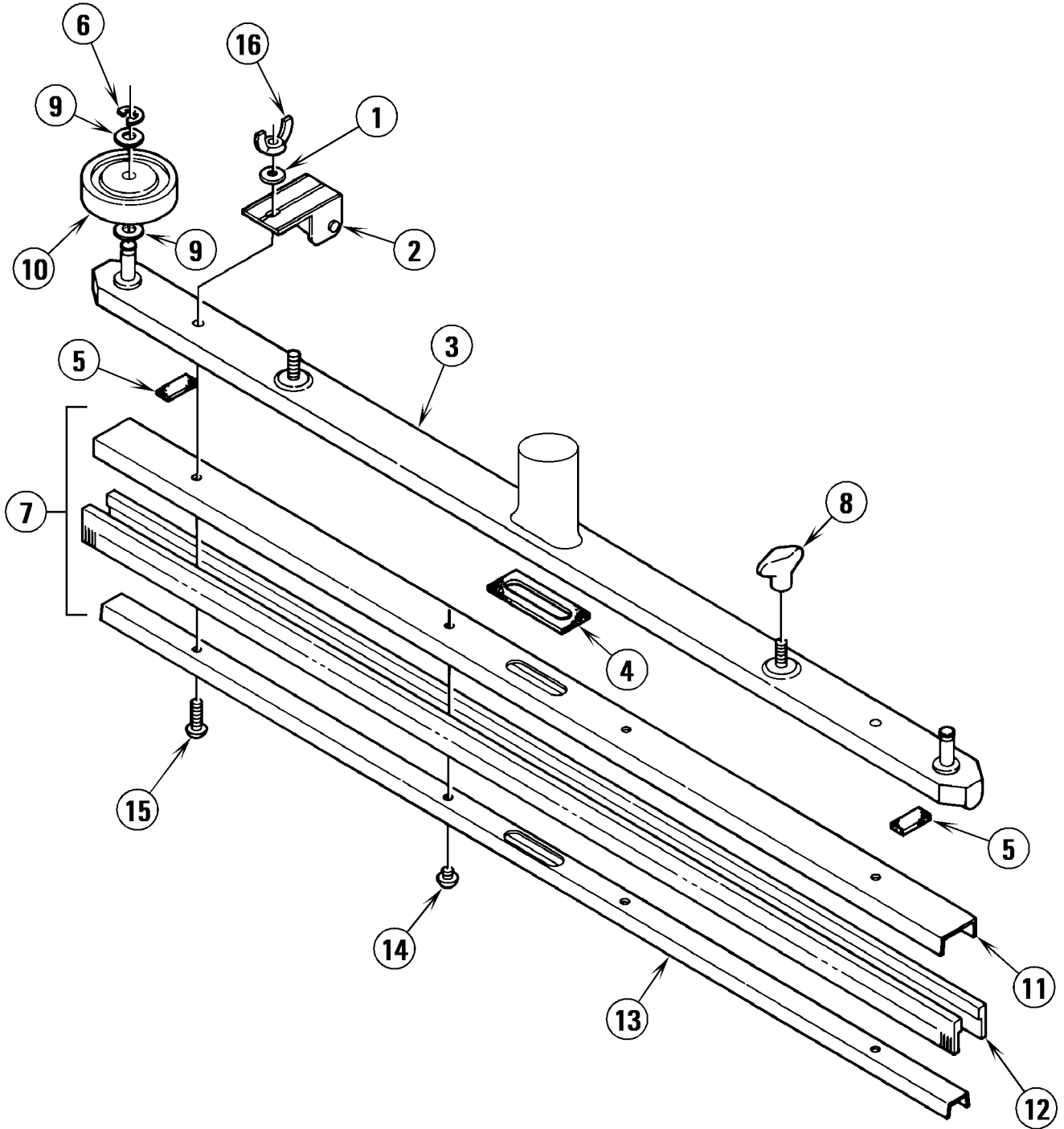

Item	Ref. No.	Qty	Description
	56264130	1	Squeegee Assy 12" (#1-10)
	56264131	1	Squeegee Assy 15" (#1-10)
	56264340	1	Squeegee Assy 18" (#1-10)
1	56002859	2	Wsh, Flt SAE SS 1/4
2	56387376	2	Roller Assy
3	56264158	1	Channel Weld't 12"
	56264170	1	Channel Weld't 15"
	56264339	1	Channel Weld't 18"
4	56400613	1	Gasket
5	56400614	2	Gasket
6	56003269	2	Ring, Ret Ext. Type E Reinf.
7	56264159	1	Squeegee Cartridge 12" (#11-16)
	56264172	1	Squeegee Cartridge 15" (#11-16)
	56264338	1	Squeegee Cartridge 18" (#11-16)
8	56370711	2	Nut, Thumb
9	56009047	4	Wsh, Flt
10	56363855	2	Wheel
11	56264160	1	Channel 12"
	56264166	1	Channel 15"
	56264331	1	Channel 18"
12	56105577	2	Blade, Squeegee 12"
	56105578	2	Blade, Squeegee 15"
	56105506	2	Blade, Squeegee 18"
13	56264161	1	Retainer 12"
	56264167	1	Retainer 15"
	56264336	1	Retainer 18"
14	56003037	2	Scr, Pan Phil SS 1/4-20 x .25
15	56003067	2	Scr, Pan Hd SS 1/4-20 x 1.00
16	56009048	2	Nut, Wing Loc 1/4-20

ACCESSORIES

94-5

34**AquaClean™ 12/15/18**

02-7

OPTIONAL HARD FLOOR BRUSHES

The AquaClean™ comes standard with a carpet brush assembly. Optional brushes for use on hard floors must be ordered separately. If you plan to clean hard floors, you should order the optional Hard Floor Kit (see page 28) for your machine and the optional brush(es) listed below.

BRUSH ASSEMBLY DESCRIPTION	12	15	18
Standard Carpet Brush (Black Bristles)	56264357	56264358	56264359
Optional Smooth Hard Floor (Blue Bristles)	56264360	56264363	56264366
Optional Light Grit Hard Floor (Gray 500)	56264361	56264364	56264367
Optional Grout Grit Hard Floor (Gray 240)	56264362	56264365	56264368
Optional MidLite Grit 180 Hard Floor	56264424	56264426	56264428

OPTIONAL ACCESSORY TOOLS

The AquaClean™ can be fitted with optional attachments which must be ordered separately. To use these accessory tools, attach the accessory vacuum hose to the left tube on the recovery tank cover. Attach the accessory solution hose to the fitting on the right rear side of the machine. Connect the other end of the vacuum and solution hoses to the accessory tool. When using accessory tools, turn the brush motor switch OFF.

CARPET TOOLS**REF. NUMBER**

4' Stainless Steel Drag Tool	56260387
Stainless Steel Hand Tool	56204203
Plastic Hand Tool	56800385
Plastic & Stainless Drag Tool	56800390
15' Scrub and Vac Hose	56249318
PowerHead™ 12 W/Adapter Kit	56250185

HARD FLOOR TOOLS**REF. NUMBER**

4' Scrub and Vac Wand	56204197
14" Scrub and Vac Tool	56250314
20" Scrub and Vac Tool	56250320
15' Scrub and Vac Hose	56249318

CHEMICALS**REF. NUMBER**

Foam Buster (case of 6 gallon)	56050100
Extraction Cleaner (case of 6 gallon)	56050098
Spot Pre Spray (case of 6 gallon)	56050099

HARD FLOOR CLEANING NOTE

Brushes and chemicals made for use on hard floors should not be used on carpet!



Nilfisk-Advance, Inc.
14600 21st Avenue North
Plymouth, MN, 55447-3408
www.nilfisk-advance.com
Phone: 800-989-2235
Fax: 800-989-6566
©2003 Nilfisk-Advance, Inc.,
Plymouth, MN 55447-3408
Printed in the U.S.A.