



Electronic Service Manuals

This electronic document is provided as a service to our customers. We do not create the contents of the information contained in this document. Should you have detailed questions pertaining to the information contained in this document, you may contact Michco, or the manufacturer which provided the original information in this electronic deliverable. Michco's only part in this electronic deliverable was the electronic assembly process.

You may contact Michco through the following methods:
Phone (517) 484-9312 or (800) 331-3339 MI, OH, IN only
2011 N. High St. -- Lansing, Michigan -- 48906
Fax: (517) 484-9836
Email: CustServ@Michco.com
Web site: www.Michco.Com
Parts Web site: www.FloorMachineParts.Com

Order Parts on Line at:
www.FloorMachineParts.Com

Directly to Parts & Service:
By Email: **Shop@Michco.com**
By Fax: (517) 702-2041
By Voice: Use numbers above.

Serving the Cleaning Industry Since 1922

Notice: All copyrighted material remains property of original owners, all trademarks are property of respective owners. Manuals are subject to Manufacturer's reproduction limitations. Originals or reproductions were provided by manufacturers through a request. We make no warranty as to the correctness of information provided in this document and you assume all risk.

AquaClean™ *Classic*



OPERATOR MANUAL
AquaClean™ MODEL 56262640



Advance
by Nilfisk-Advance

4/95 revised 1/02 Form Number 56041303

TABLE OF CONTENTS

	PAGE
Introduction	3
Parts and Service	3
Nameplate	3
Uncrating	3
Important Safety Instructions	4
Importantes Mesures De Sécurité	5
Grounding Instructions	6
Operating Controls	7
Preparing the Machine	8
Solution Tank	8
Pre-Spraying Carpet	8
Plan for Cleaning	8
Operation	8
Using Accessories	8
After Use	9
Maintenance	9
Power Brush	9
Vacuum Shoe	9
Vacuum Motor Brushes	9
Spray Nozzle	9
Lubrication	9
Troubleshooting	10
Circuit Breaker Tripping	10

INTRODUCTION

This manual will help you get the most from your **Nilfisk-Advance AquaClean™**. Read it thoroughly before operating the machine.

This product is intended for commercial use only.

PARTS AND SERVICE

Repairs, when required, should be performed by Nilfisk-Advance service personnel using Nilfisk-Advance original replacement parts and accessories.

Call Nilfisk-Advance for repair parts or service. Please specify the Model and Serial Number when discussing your machine.

NAME PLATE

The Model and Serial Number of your machine are shown on the Nameplate on the machine. This information is needed when ordering repair parts for the machine. Use the space below to note the Model and Serial Number of your machine for future reference.

MODEL _____

SERIAL NUMBER _____

UNCRATING

When the machine is delivered, carefully inspect the shipping carton and the machine for damage. If damage is evident, save the shipping carton so that it can be inspected. Contact the Nilfisk-Advance Customer Service Department immediately to file a freight damage claim.

IMPORTANT SAFETY INSTRUCTIONS

This machine is only suitable for commercial use, for example in hotels, schools, hospitals, factories, shops and offices other than normal residential housekeeping purposes.

When using an electrical appliance, basic precautions should always be followed, including the following:

Read all instructions before using.

WARNING!

To reduce the risk of fire, electric shock, or injury:

- * Do not leave the appliance when it is plugged in. Unplug the unit from the outlet when not in use and before servicing.
- * To avoid electric shock, do not expose to rain. Store indoors.
- * Do not allow to be used as a toy. Close attention is necessary when used by or near children.
- * Use only as described in this manual. Use only manufacturer's recommended attachments.
- * Do not use with damaged cord or plug. If the appliance is not working as it should, has been dropped, damaged, left outdoors, or dropped into water, return it to a service center.
- * Do not pull or carry by cord, use cord as a handle, close a door on cord, or pull cord around sharp edges or corners. Do not run appliance over cord. Keep cord away from heated surfaces.
- * Do not unplug by pulling on cord. To unplug, grasp the plug, not the cord.
- * Do not handle plug or appliance with wet hands.
- * Do not put any object into openings. Do not use with any opening blocked; keep free of dust, lint, hair, and anything that may reduce air flow.
- * Keep hair, loose clothing, fingers, and all parts of body away from openings and moving parts.
- * Do not pick up anything that is burning or smoking, such as cigarettes, matches, or hot ashes.
- * Turn off all controls before unplugging.
- * Use extra care when cleaning on stairs.
- * Do not use to pick up flammable or combustible liquids such as gasoline or use in areas where they may be present.
- * Connect to a properly grounded outlet only. See Grounding Instructions.

SAVE THESE INSTRUCTIONS

IMPORTANTES MESURES DE SÉCURITÉ

Cette machine ne convient qu'à un usage industriel, par exemple dans les hôtels, les écoles, les hôpitaux, les usines, les boutiques et bureaux et tout ce qui n'est pas pour l'entretien domestique résidentiel normal.

Lors de l'utilisation d'un appareil électrique, suivez toujours les précautions d'usage, y compris celles qui suivent :

Lisez toutes les instructions avant de faire fonctionner l'aspirateur.

AVERTISSEMENT!

Pour réduire les risques d'incendie, de choc électrique ou de blessure:

- * Ne pas laisser l'appareil sans surveillance lorsqu'il est branché. Débrancher lorsque l'appareil n'est pas utilisé et avant l'entretien.
- * Pour réduire les risques de choc électrique, utiliser à l'intérieur seulement.
- * Ne pas permettre aux enfants de jouer avec l'appareil. Une attention particulière est nécessaire lorsque l'appareil est utilisé par des enfants ou à proximité de ces derniers.
- * N'utiliser que conformément à cette notice avec les accessoires recommandés par le fabricant.
- * Ne pas utiliser si le cordon ou la fiche est endommagé. Retourner l'appareil à un atelier de réparation s'il ne fonctionne pas bien, s'il est tombé ou s'il a été endommagé, oublié à l'extérieur ou immergé.
- * Ne pas tirer soulever ou traîner l'appareil par le cordon. Ne pas utiliser le cordon comme une poignée, le coincer dans l'embrasure d'une porte ou l'appuyer contre des arêtes vives ou des coins. Ne pas faire rouler l'appareil sur le cordon. Garder le cordon à l'écart des surfaces chaudes.
- * Ne pas débrancher en tirant sur le cordon. Tirer plutôt la fiche.
- * Ne pas toucher la fiche ou l'appareil lorsque vos mains sont humides.
- * N'insérer aucun objet dans les ouvertures. Ne pas utiliser l'appareil lorsqu'une ouverture est bloquée. S'assurer que de la poussière, de la peluche, des cheveux ou d'autres matières ne réduisent pas le débit d'air.
- * Maintenir les cheveux, les vêtements amples, les doigts et toutes les parties du corps à l'écart des ouvertures et des pièces mobiles.
- * Ne pas aspirer de matières en combustion ou qui dégagent de la fumée, comme des cigarettes, des allumettes ou des cendres chaudes.
- * Mettre toutes les commandes à la position ARRÊT avant de débrancher l'appareil.
- * User de prudence lors du nettoyage des escaliers.
- * Ne pas aspirer des liquides inflammables ou combustibles, comme de l'essence, et ne pas faire fonctionner dans des endroits où peuvent se trouver de tels liquides.
- * Ne brancher qu'à une prise de courant avec mise à la terre. Voir les instructions visant la mise à la terre.

CONSERVER CES INSTRUCTIONS

120VAC GROUNDING INSTRUCTIONS

This appliance must be grounded. If it should electrically malfunction, grounding provides a path of least resistance for electric current to reduce the risk of electric shock. This appliance is equipped with a cord having an equipment-grounding conductor and grounding plug. The plug must be plugged into an appropriate outlet that is properly installed and grounded in accordance with all local codes and ordinances.

⚠ DANGER!

Improper connection of the equipment-grounding conductor can result in a risk of electric shock. Check with a qualified electrician or service person if you are in doubt as to whether the outlet is properly grounded. Do not modify the plug provided with the appliance. If it will not fit the outlet, have a proper outlet installed by a qualified electrician.

This appliance is for use on a nominal 120-volt circuit, and has a grounding plug that looks like the plug illustrated in Figure 1 below. A temporary adapter illustrated in Figures 2 and 3 may be used to connect this plug to a 2-pole receptacle as shown in Figure 2 if a properly grounded outlet is not available. The temporary adapter should be used only until a properly grounded outlet (Figure 1) can be installed by a qualified electrician. The green-colored rigid ear, tab, or the like extending from the adapter must be connected to a permanent ground such as a properly grounded outlet box cover. Whenever the adapter is used, it must be held in place by a metal screw. Grounding adapters are not approved for use in Canada.

Replace the plug if the grounding pin is damaged or broken.

The Green (or Green/Yellow) wire in the cord is the grounding wire. When replacing a plug, this wire must be attached to the grounding pin only. Extension cords connected to this machine should be 12 gauge, three-wire cords with three-prong plugs and outlets. DO NOT use extension cords more than 50 feet (15 m) long.

PLEASE NOTE: FOR NORTH AMERICA ONLY

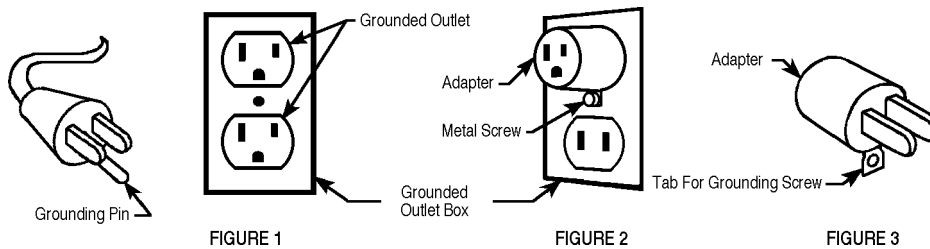

INSTRUCTIONS VISANT LA MISE À LA TERRE (120VAC)

Cet appareil doit être mis à la terre. En cas de défaillance ou de panne éventuelles, la mise à la terre fournit au courant un chemin de moindre résistance qui réduit le risque de choc électrique. Cet appareil est pourvu d'un cordon muni d'un conducteur de terre et d'une fiche avec broche de terre. La fiche doit être branchée dans une prise appropriée correctement installée et mise à la terre conformément aux règlements et ordonnances municipaux.

⚠ AVERTISSEMENT !

Un conducteur de terre mal raccordé peut entraîner un risque de choc électrique. Consulter un électricien ou un technicien d'entretien qualifié si vous n'êtes pas certain que la prise est correctement mise à la terre. Ne pas modifier la fiche fournie avec l'appareil - si elle ne peut être insérée dans la prise, faire installer une prise adéquate par un électricien qualifié.

Cet appareil est destiné à un circuit de 120 V et est muni d'une fiche de terre semblable à celle illustrée par le croquis 1. Un adaptateur temporaire semblable à celui illustré par le croquis 2 et C peut être utilisé pour brancher cette fiche à une prise bipolaire comme l'illustre le croquis 2 si une prise avec mise à la terre n'est pas disponible. L'adaptateur temporaire devrait être utilisé seulement jusqu'à ce qu'une prise avec mise à la terre soit installée par un électricien qualifié. L'oreille rigide ou le crochet ou autre dispositif semblable, de couleur verte, prolongeant l'adaptateur doit être raccordé à un élément correctement mis à la terre comme le couvercle d'une boîte de sortie mise à la terre. L'adaptateur doit être fixé par une vis métallique. **Note:** Au Canada, l'utilisation d'un adaptateur temporaire n'est pas autorisée par le Code canadien de l'électricité.

Remplacez la prise si la prise de terre est abîmée ou cassée.

Le fil Vert (ou Vert/Jaune) dans la gaine est le fil de terre. Lors du remplacement d'une prise, ce fil doit être raccordé à la prise de terre uniquement.

Les ralongs connectés à cette machine doivent avoir 12 mesures, trois ganses de fil ayant trois fiches masculines féminines tree-prong plugs and outlets. N'UTILISEZ PAS de ralonge de plus de 15 m (50 pieds) de long.

VEUILLEZ NOTER: CES INSTRUCTIONS CONCERNENT UNIQUEMENT L'AMÉRIQUE DU NORD

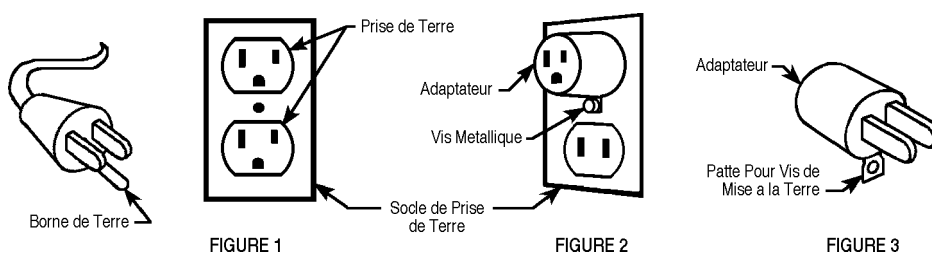

OPERATING CONTROLS

- 1 Handle Release Pedal
- 2 Brush Height Control Knob
- 3 Solution Drain and Sight Tube
- 4 Brush Switch
- 5 9 Amp Brush Motor Circuit Breaker
- 6 13 Amp Vacuum Motor Circuit Breaker
- 7 Master Power Switch
- 8 Solution Control Cord

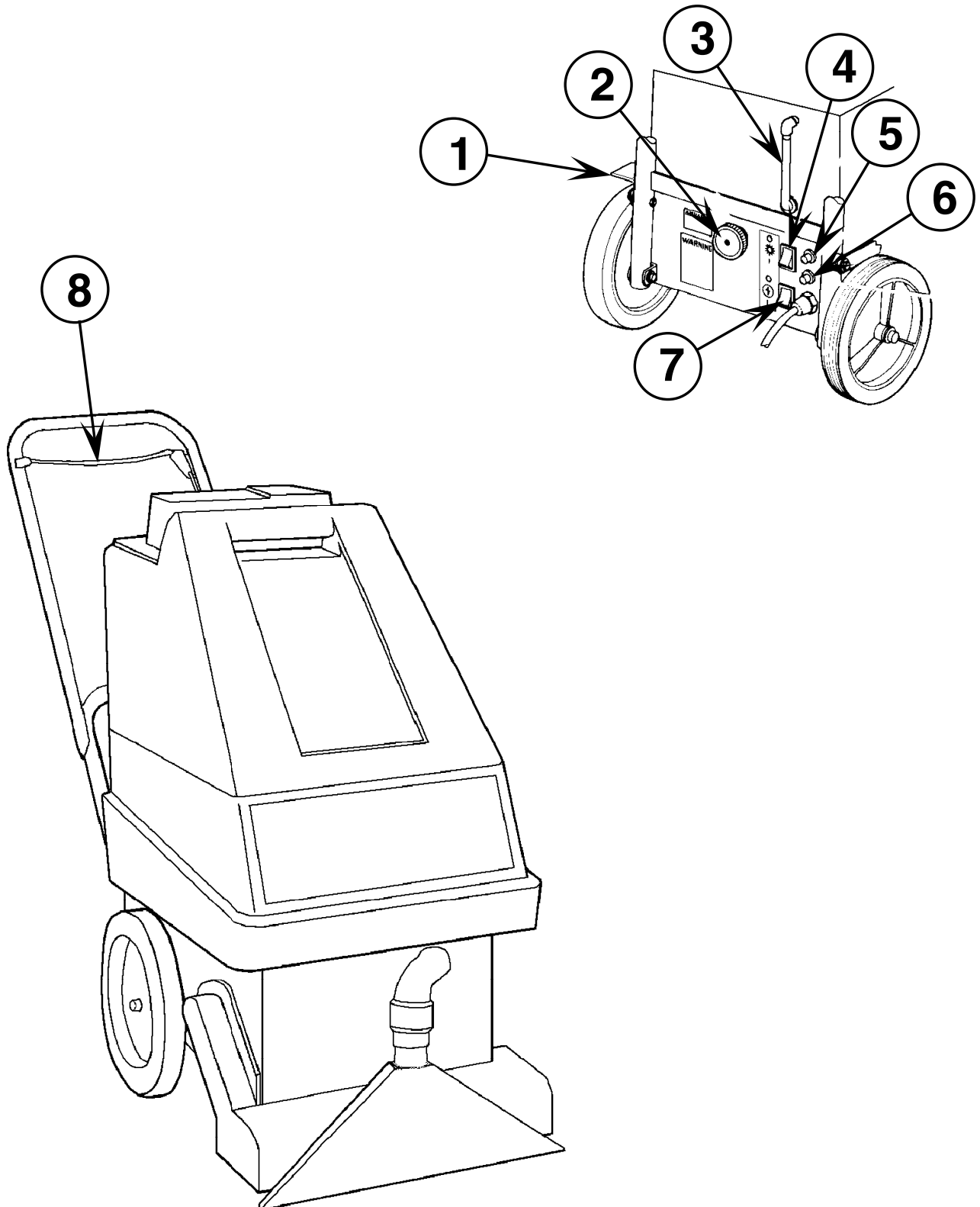

PREPARING THE MACHINE

SOLUTION TANK

To Fill the Solution Tank:

- 1 Lift the recovery (top) tank off the machine.
- 2 Read the dilution instructions on the chemical container. Then figure the proper amount of chemical to mix with 7 gallons (26.5 liters) of water.
- 3 Pour the chemical in the solution tank and fill the tank the rest of the way with warm water.
- 4 Put the recovery tank on the machine.
- 5 Put the cover on the recovery tank.

The recovery tank may be used (like a bucket) to carry water for the solution tank. Rinse all dirt from the recovery tank before filling it with clean water for the solution tank.

PRE-SPRAYING CARPET

Pre-spray spots and traffic lanes before extracting. Use a hand-held bottle sprayer or a pressurized "Hudson" type sprayer. Mix the pre-spray according to the chemical manufacturers directions. For best results, use an Nilfisk-Advance CarpeTeam pre-spray chemical specially formulated for Nilfisk-Advance carpet extractors.

PLAN FOR CLEANING

Before you begin extracting, look at the area to be cleaned and plan your work. Divide the space into sections. Work away from where you plug in the electrical cable. Overlap each pass 2 inches (5 cm).

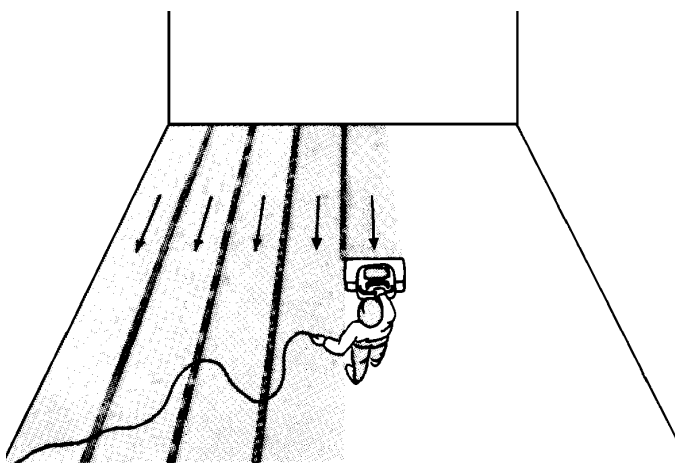

OPERATION

- 1 Fill the solution tank with the proper dilution of warm water and extractor chemical.
- 2 Unwrap the Power Cord and plug it into a properly grounded outlet.
- 3 Turn the Master Switch ON.
- 4 Turn the Brush Switch ON.
- 5 Lower the Handle.
- 6 Turn the Brush Height Adjustment Knob until the machine just begins to move backward. Do not set the brush too low as this will cause the circuit breaker to trip. If the circuit breaker does trip, wait 5 minutes for it to cool, then push the button in to reset it.
- 7 Push down on the Handle and move the machine (on its rear set of wheels) to its starting position.
- 8 Pull the machine back slowly, dispensing solution as you go. Pick up all of the solution on each pass.
- 9 Watch the fluid entering the recovery tank. If there is a large amount of suds in the recovery tank, add a defoamer chemical to the recovery tank.

⚠ CAUTION!

Empty the tank before the fluid or foam enters the right tube on the recovery tank cover.

USING ATTACHMENTS

To use accessory tools, attach the accessory vacuum hose to the left tube on the recovery tank cover. Attach the accessory solution hose to the quick disconnect fitting on the lower left side of the machine. Connect the other end of the vacuum and solution hoses to the accessory tool. When using accessory tools, turn the Brush Motor Switch OFF.

See your Nilfisk-Advance Distributor for accessories and chemicals that may be used with your extractor including:

- 56260387 Extractor Wand (Stainless Steel)
- 56249318 15 foot (4.5 meter) Extractor Hose Assembly
- 56204203 Hand-Held Stair Tool
- 56801000 Aqua Kit (includes the 2 items below)
 - 56800385 Plastic Hand Tool
 - 56800390 Plastic and Stainless Drag Tool
- 56050098 Extraction Cleaner - case of 6 gallons
- 56050099 Pre-Spray - case of 6 gallons
- 56050100 Foam Buster - case of 6 gallons

AFTER USE

- 1 Turn the Master Switch and the Brush Switch OFF.
- 2 Unplug the Power Cord and wrap it around the handle.
- 3 Empty the recovery tank, rinse it clean and wipe it dry.
- 4 Empty the solution tank. To drain, pull the clear hose down and off of the storage peg. When the tank is empty, put the hose back on the storage peg.
- 5 Remove any dirt from the filter screen in the solution tank.
- 6 Put the recovery tank and its cover back on the machine.
- 7 Push the handle to the forward, locked position so the brush housing raises clear of the floor. This will prevent the brush from taking a "set".

For more compact storage, remove the recovery tank, loosen the handle wing nuts and push the handle down over the solution tank.

- 8 Perform any required maintenance before **storage**.
- 9 Store in a clean, dry place.

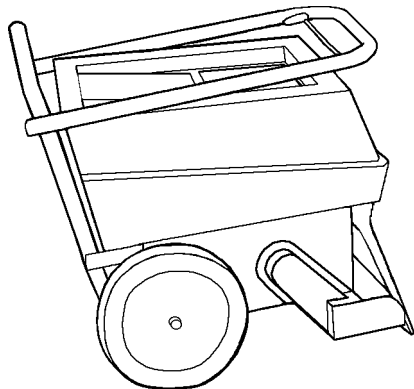

MAINTENANCE

POWER BRUSH

Periodically check the brush and remove any built-up string, hair or carpet fibers.

VACUUM SHOE

Periodically check the vacuum shoe and remove any built-up string, hair or carpet fibers.

VACUUM MOTOR BRUSHES

Have the vacuum motor carbon brushes checked every 450 hours by a qualified Nilfisk-Advance service person. Replace the carbon brushes if they are worn to 3/8" (9.5 mm) or less.

IMPORTANT!

Motor damage resulting from failure to service carbon brushes is not covered under warranty. See the Limited Warranty statement.

SPRAY NOZZLE

Remove the Spray Nozzle (A) once a week and soak it overnight in a vinegar and water rinse to remove chemical deposits.

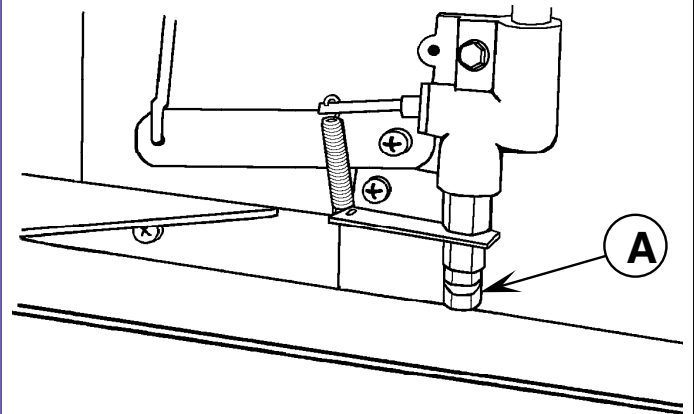

LUBRICATION

Once a month (or every 30 hours) lubricate all pivot points associated with the valve assembly on the bottom of the machine. For best results, use a spray silicone lubricant.

TROUBLESHOOTING

CIRCUIT BREAKER TRIPPING

Circuit breakers protect electrical circuits and motors from damage due to overload conditions. If a circuit breaker trips, unplug the power cord from the electrical outlet. Then try to determine the cause and correct it.

Once the problem has been corrected, reset the circuit breaker by pushing the button in. If the button does not stay in, wait 5 minutes and try again. If the circuit breaker trips repeatedly, call your local Nilfisk-Advance Dealer for service.

Possible causes for the 9 amp Brush Motor Circuit Breaker to trip:

- Debris wrapped around the brush
- Brush Height Knob not properly adjusted
- Worn brush assembly bearings

Possible causes for the 13 amp Vacuum Motor Circuit Breaker to trip:

- Vacuum motor needs service (worn carbon brushes and bearings)
- Foam entering Vacuum motor (use low-sudsing extraction cleaner)
- Vacuum motor airways blocked
 - Clean dome lid on recovery tank
 - Clear hoses of debris
 - Keep vacuum motor exhaust area open

NOTE: An internal thermal overload device is built into the vacuum motor. This stops the motor when airflow needed for cooling is restricted.



Nilfisk-Advance, Inc.
14600 21st Avenue North
Plymouth, MN, 55447-3408
www.nilfisk-advance.com
Phone: 800-989-2235
Fax: 800-989-6566
©2001 Nilfisk-Advance, Inc.,
Plymouth, MN 55447-3408
Printed in the U.S.A.