



Electronic Service Manuals

This electronic document is provided as a service to our customers. We do not create the contents of the information contained in this document. Should you have detailed questions pertaining to the information contained in this document, you may contact Michco, or the manufacturer which provided the original information in this electronic deliverable. Michco's only part in this electronic deliverable was the electronic assembly process.

You may contact Michco through the following methods:
Phone (517) 484-9312 or (800) 331-3339 MI, OH, IN only
2011 N. High St. -- Lansing, Michigan -- 48906
Fax: (517) 484-9836
Email: CustServ@Michco.com
Web site: www.Michco.Com
Parts Web site: www.FloorMachineParts.Com

Order Parts on Line at:
www.FloorMachineParts.Com

Directly to Parts & Service:
By Email: **Shop@Michco.com**
By Fax: (517) 702-2041
By Voice: Use numbers above.

Serving the Cleaning Industry Since 1922

Notice: All copyrighted material remains property of original owners, all trademarks are property of respective owners. Manuals are subject to Manufacturer's reproduction limitations. Originals or reproductions were provided by manufacturers through a request. We make no warranty as to the correctness of information provided in this document and you assume all risk.

ConvertaMAX™ 20/26

BA 550 / BA 650

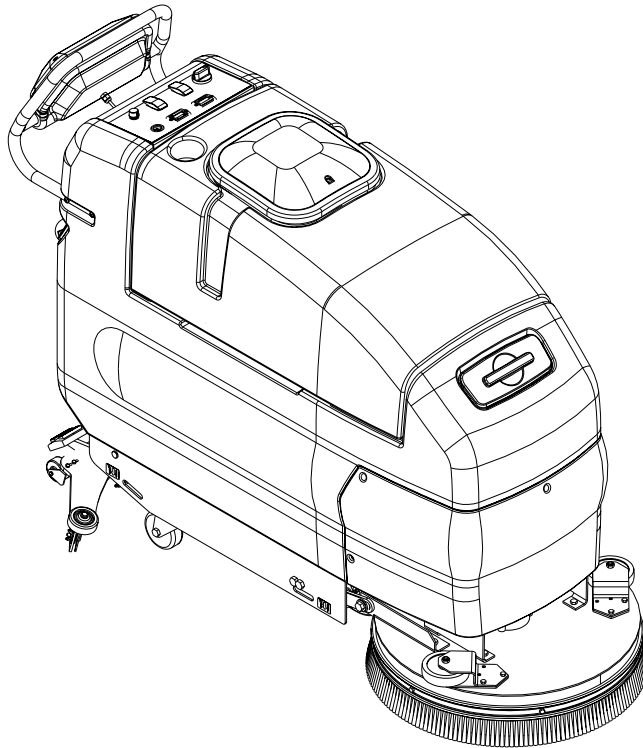

PARTS LIST

Advance MODELS 56397010, 56397011

Nilfisk MODELS 56397012, 56397013

All models covered in this manual are Obsolete.

ConvertaMAX 20 before SN1573667 / ConvertaMAX 26 before SN1573672

BA 550 before SN1573799 / BA 650 before SN1573804



**Nilfisk
Advance**

setting standards

8/99 revised 8/02 FORM NO. 56042380
BOOK E SECTION 4.3.1

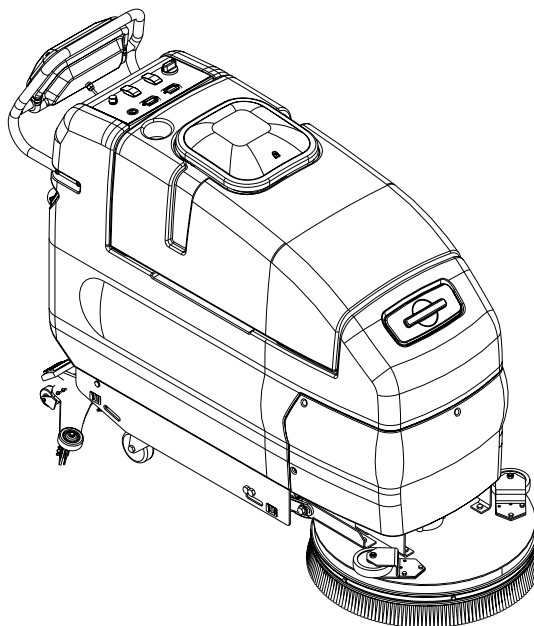

DESCRIPTION	PLAN
CHASSIS SYSTEM (BEFORE April 2001)	E-4.3.1-3
CHASSIS SYSTEM (AFTER March 2001)	E-4.3.1-5
HANDLE SYSTEM	E-4.3.1-7
DRIVE SYSTEM	E-4.3.1-9
20" SCRUB SYSTEM	E-4.3.1-11
26" SCRUB SYSTEM (W/BOLT-ON SKIRT)	E-4.3.1-13
26" SCRUB SYSTEM (W/SLIDE-ON SKIRTS)	E-4.3.1-15
SOLUTION SYSTEM	E-4.3.1-17
RECOVERY SYSTEM	E-4.3.1-19
20" SQUEEGEE SYSTEM	E-4.3.1-21
26" SQUEEGEE SYSTEM	E-4.3.1-23
DECAL SYSTEM	E-4.3.1-25
ELECTRICAL SYSTEM	E-4.3.1-27
ELECTRICAL DIAGRAM	E-4.3.1-29

WHEN ORDERING PARTS

- * Use the 8 digit numbers from the "Ref. No." columns in this parts list.
- * Specify the model and serial number of the machine.
- * Use the space below to record the model and serial number for future reference.

Model _____ Serial No. _____

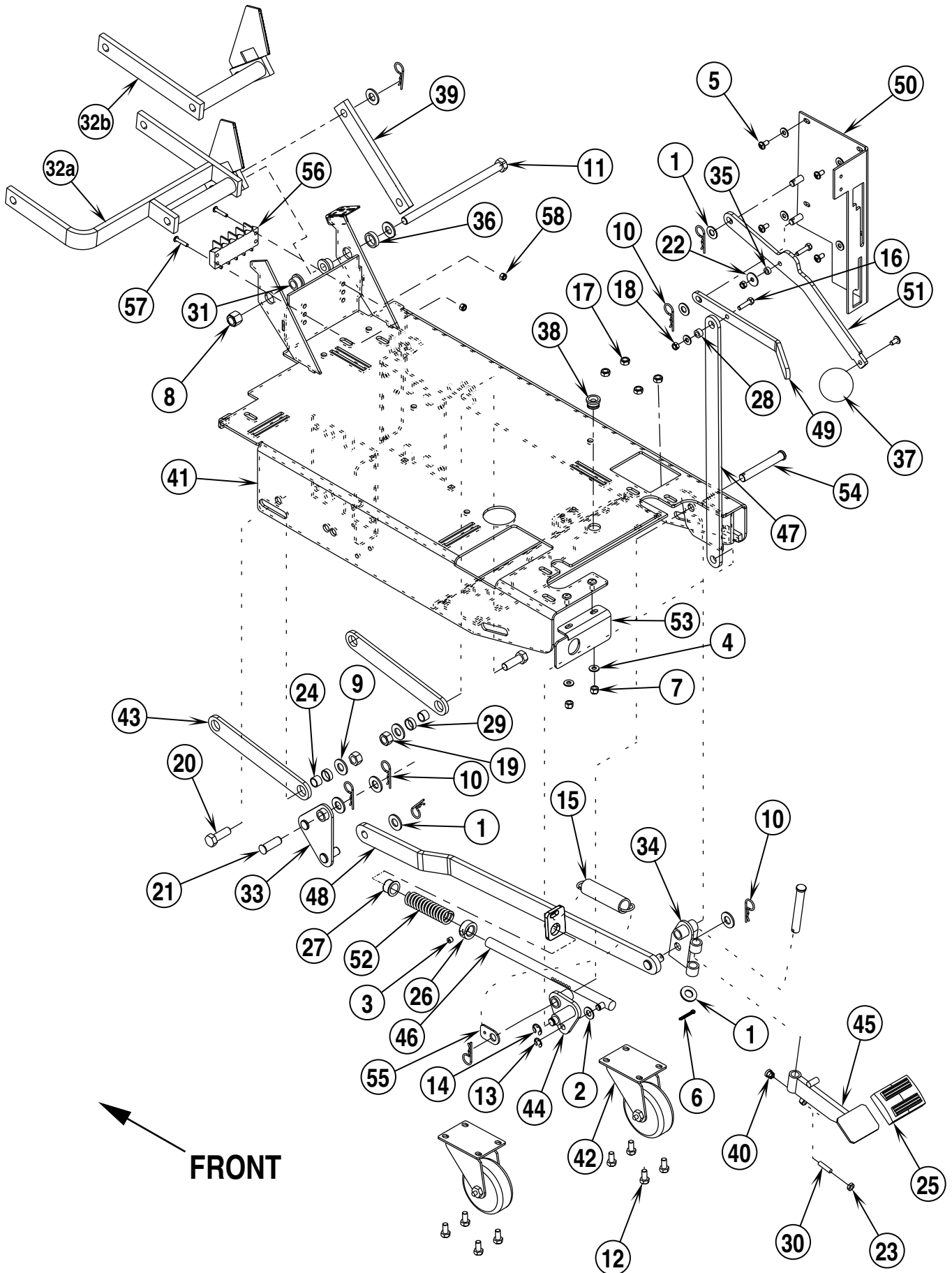

99-8	CHASSIS SYSTEM (BEFORE April 2001)	BOOK E		
01-6	ConvertaMAX™ 20, 26 / BA 550, BA 650	E	4.3.1	3

Item	Ref. No.	Qty	Description	Item	Ref. No.	Qty	Description
1	56001879	7	Wsh, Flt SAE 1/2	33	56035589	1	Weld't, Linkage, Triangular
2	56002063	1	Wsh, Flt SAE 3/8	34	56035590	1	Weld't, Pivot, Foot Pedal
3	56002086	1	Scr, Soc Set Loc 5/16-18 x .25	35	56054335	1	Spacer, Steel
4	56002098	7	Wsh, Flt SAE 1/4	36	56054581	1	Spacer, Steel
5	56002145	5	Scr, Pan Phil 1/4-20 x .50	37	56397153	1	Ball Knob
6	56002529	1	Pin, Cotter 1/8 x 1.00	38	56057764	1	Bushing, Guide
7	56002708	2	Nut, Hex Nyl Loc 1/4-20	39	56057771	1	Bar, Steel
8	56002770	1	Nut, Hex Nyl Loc 1/2-13	40	56057842	1	Plug, Button
9	56002918	2	Wsh, Flt SAE SS 1/2	41	56397008	1	Weldment, Frame NOTE
10	56002959	8	Pin, Cotter Hair	42	56397016	2	Wheel, Caster
11	56003159	1	Scr, Hex Hd 1/2-13 x 8.50	43	56397049	2	Arm
12	56003178	8	Scr, Hex M8-1.25 x 16mm	44	56397054	1	Pivot, Foot Weldment
13	56003262	1	Ring, Ret Ext Type E .38 Dia.	45	56397056	1	Weld't, Pedal Lever TSB 742
14	56003264	1	Ring, Ret Ext Type E .50 Dia.	46	56397057	1	Rod Weldment
15	56456847	1	Spring, Extension (26" models only)	47	56397060	1	Linkage, Brush Lift
16	56003358	2	Scr, Hex M6-1.00 x 25mm	48	56397062	1	Bar Weldment
17	56003389	8	Nut, Hex Nyl Loc M8-1.25	49	56397063	1	Bar
18	56003403	2	Nut, Hex Nyl Loc M6-1.00	50	56397064	1	Weld't, Panel
19	56003450	2	Nut, Hex Nyl Loc SS M12-1.75	51	56397086	1	Arm
20	56003453	2	Scr, Hex Hd SS M12-1.75 x 35mm	52	56397131	1	Compression Spring
21	56003514	1	Clevis Pin .50 x 1.25	53	56397136	1	Bracket, Rear Cover
22	56009002	1	Wsh, Flt .266 x .906 x .060	54	56003519	2	Clevis Pin, .50 x 3.50
23	56009087	1	Nut, Hex Jam 1/4-20	55	56397132	1	Plate (26" models only)
24	56360627	3	Bushing	56	56026111	1	Term. Block, 4 Term. 50 Amp
25	56365002	1	Pad, Rubber	57	56002898	2	Scr, Pan Phil SS 10-24 x 1.00
26	56367354	1	Collar, Shaft	58	56002836	2	Nut, Hex Nyl Loc SS 10-24
27	56393792	1	Bearing, Flange				
28	56453691	1	Spacer				
29	56478781	2	Bearing, Sleeve				
30	56003522	1	Screw, Set				
31	56027131	2	Bearing, Flange				
32a	56035588	1	Weld't, Brush Lift (20" models only) NOTE				
32b	56035587	1	Weld't, Brush Lift (26" models only) NOTE				

NOTE: These part numbers apply to machines before the following serial numbers.
 ConvertaMAX™ 20 before SN 1477766
 ConvertaMAX™ 26 before SN 1477788
 BA 550 / BA 650 before SN 1477797

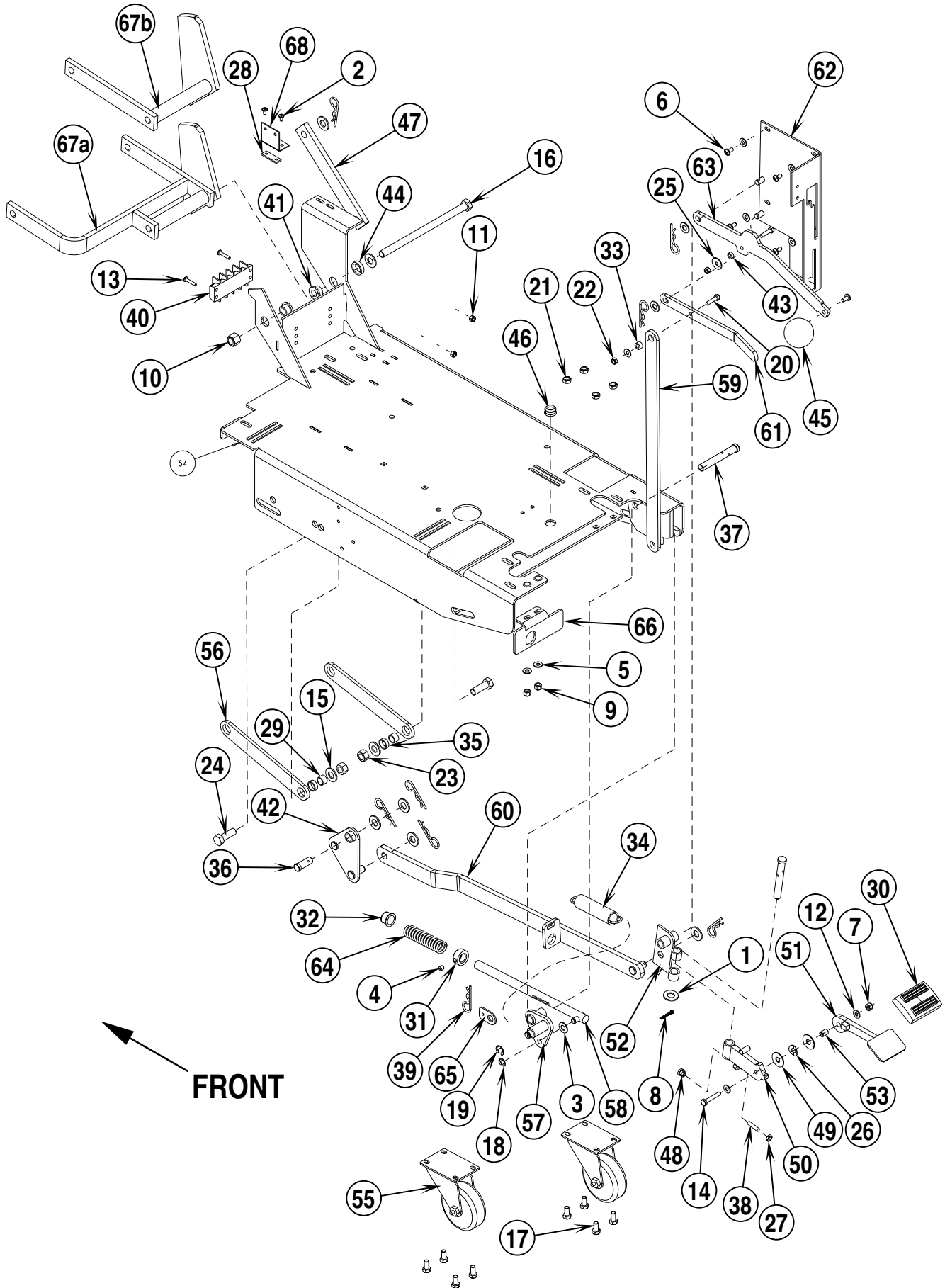

99-8	CHASSIS SYSTEM (AFTER March 2001)	BOOK E		
01-6	ConvertaMAX™ 20, 26 / BA 550, BA 650	E	4.3.1	5

Item	Ref. No.	Qty	Description	Item	Ref. No.	Qty	Description
1	56001879	7	Wsh, Flt SAE 1/2	36	56003514	1	Clevis Pin .50 x 1.25
2	56002043	2	Scr, Pan Phil 10-24 x .38	37	56003519	2	Clevis Pin .50 x 3.50
3	56002063	3	Wsh, Flt SAE 3/8	38	56003522	1	Screw, Set
4	56002086	1	Scr, Soc Set Loc 5/16-18 x .25	39	56003644	8	Pin, Cotter Hair .12 x .50
5	56002098	7	Wsh, Flt SAE 1/4	40	56026111	1	Term. Block, 4 Term. 50 Amp
6	56002145	5	Scr, Pan Phil 1/4-20 x .50	41	56027131	2	Bearing, Flange - .50 ID x .75 OD x .50
7	56002491	1	Nut, Hex Nyl Loc SS 1/4-20	42	56035589	1	Weld't, Linkage Triangular
8	56002529	1	Pin, Cotter 1/8 x 1.00	43	56054335	1	Spacer, Steel
9	56002708	2	Nut, Hex Nyl Loc 1/4-20	44	56054581	1	Spacer, Steel
10	56002770	1	Nut, Hex Nyl Loc 1/2-13	45	56057391	1	Ball Knob
11	56002836	2	Nut, Hex Nyl Loc SS 10-24	46	56057764	1	Bushing, Guide
12	56002859	2	Wsh, Flt SAE SS 1/4	47	56057771	1	Bar, Steel
13	56002898	2	Scr, Pan Phil SS 10-24 x 1.00	48	56057842	1	Plug, Button
14	56002901	1	Scr, Hex Hd SS 1/4-20 x 1.50	49	56151068	2	Washer, Fibre
15	56002918	2	Wsh, Flt SAE SS 1/2	50	56396239	1	Weld't, Pedal Lever
16	56003159	1	Scr, Hex Hd 1/2-13 x 8.50	51	56396240	1	Weld't, Pedal Lever
17	56003178	8	Scr, Hex M8-1.25 x 16mm	52	56396244	1	Weld't, Foot Pedal Pivot
18	56003262	1	Ring, Ret Ext Type E .38 Dia	53	56396249	1	Bushing
19	56003264	1	Ring, Ret Ext Type E .50 Dia	54	56397008	1	Weld't, Frame NOTE
20	56003358	2	Scr, Hex M6-1.00 x 25mm	55	56397016	2	Wheel, Caster
21	56003389	8	Nut, Hex Nyl Loc M8-1.25	56	56397049	2	Arm
22	56003403	2	Nut, Hex Nyl Loc M6-1.00	57	56397054	1	Pivot, Foot Weld't
23	56003450	2	Nut, Hex Nyl Loc SS M12-1.75	58	56397057	1	Rod Weld't
24	56003453	2	Scr, Hex Hd SS M12-1.75 x 35mm	59	56397060	1	Linkage, Brush Lift
25	56009002	1	Wsh, Flt .266 x .906 x .060	60	56397062	1	Bar Weld't
26	56009024	1	Wsh, Bowed .375 x .844 x .060	61	56397063	1	Bar
27	56009087	1	Nut, Hex Jam 1/4-20	62	56397064	1	Weld't, Panel
28	56324310	1	Nut Plate NOTE	63	56397086	1	Arm
29	56360627	2	Bushing	64	56397131	1	Compression Spring
30	56365002	1	Pad, Rubber	65	56397132	1	Plate (26" models only)
31	56367354	1	Collar, Shaft	66	56397136	1	Bracket, Rear Cover
32	56393792	1	Bearing, Flange	67a	56397146	1	Weld't, Brush Lift (20" models only) NOTE
33	56453691	1	Spacer	67b	56397197	1	Weld't, Brush Lift (26" models only) NOTE
34	56456847	1	Spring, Extension (26" models only)	68	56397199	1	Bracket, Switch NOTE
35	56478781	2	Bearing, Sleeve				

NOTE: These part numbers apply to machines after the following serial numbers.
 ConvertaMAX™ 20 after SN 1477765
 ConvertaMAX™ 26 after SN 1477787
 BA 550 / BA 650 after SN 1477796

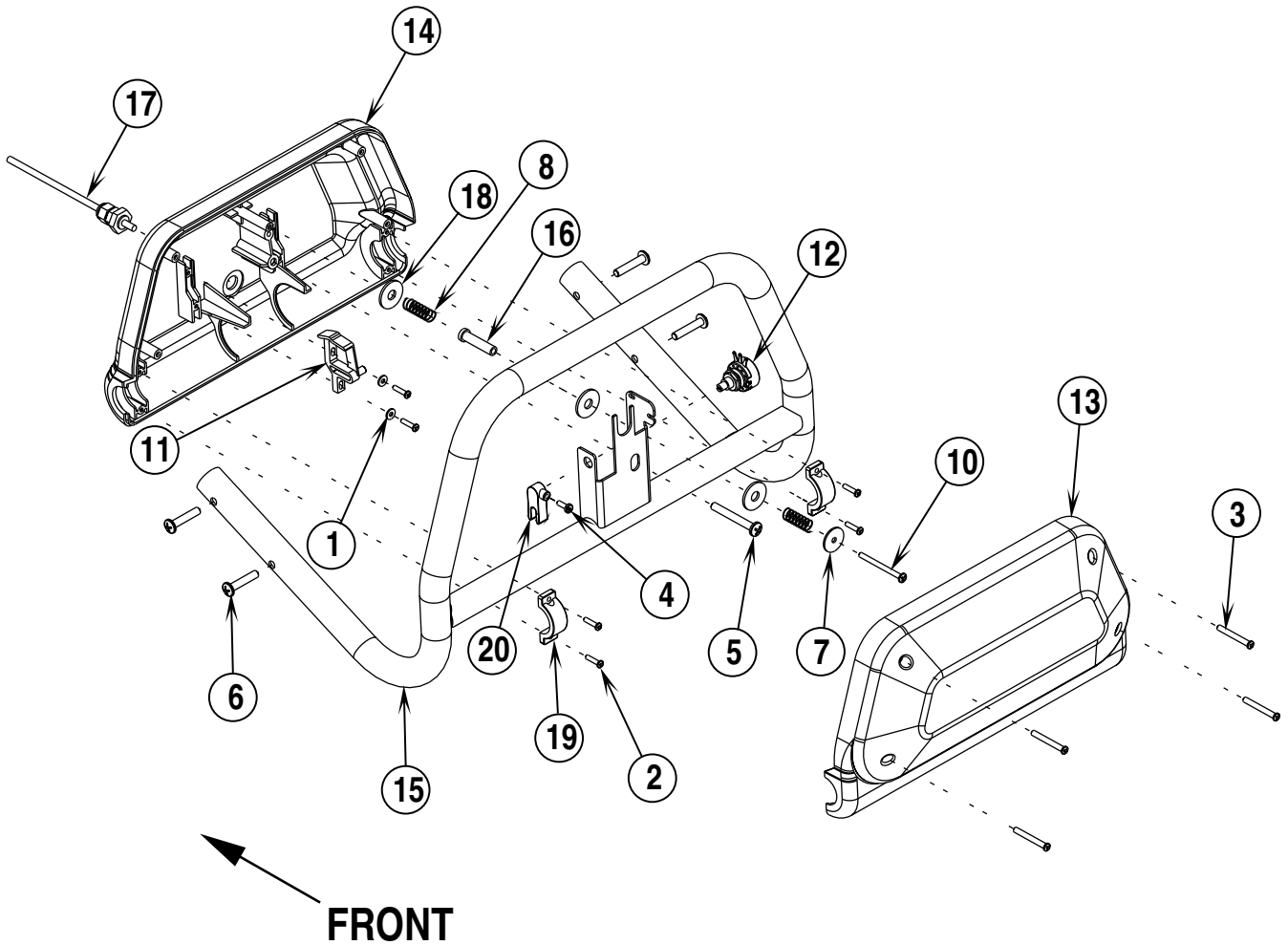

99-8	HANDLE SYSTEM	BOOK E		
00-12	ConvertaMAX™ 20, 26 / BA 550, BA 650	E	4.3.1	7

Item	Ref. No.	Qty	Description
1	56002006	2	Wsh, Flt SAE #6
2	56003197	6	Scr, Pan Phil Plastite 6-18 x .62
3	56003199	4	Scr, Pan Phil Plastite 8-15 x 1.50
4	56003354	1	Scr, Pan Phil M4 x 12.00
5	56003527	1	Scr, Pan Phil Plastite 1/4-10 x 2.00
6	56009090	4	Scr, Pan Phil Loc 1/4-20 x 1.25
7	56009096	1	Wsh, Flt .193 x .875 x .060
8	56325654	2	Spring, Compression
9			Intentionally Omitted
10	56009287	1	Scr, Pan Phil Type B 8 x 2.00
11	56397015	1	Cam Controller
12	56397029	1	Potentiometer, 5K
13	56397030	1	Paddle, Front Molded
14	56397031	1	Paddle, Back Molded
15	56397034	1	Weldment, Handle
16	56397109	1	Sleeve
17	56397110	1	Wiring Harness Assembly TSB 737
18	56397170	3	Washer, Plastic
19	56397171	2	Clamp
20	56397172	1	Potentiometer Fork

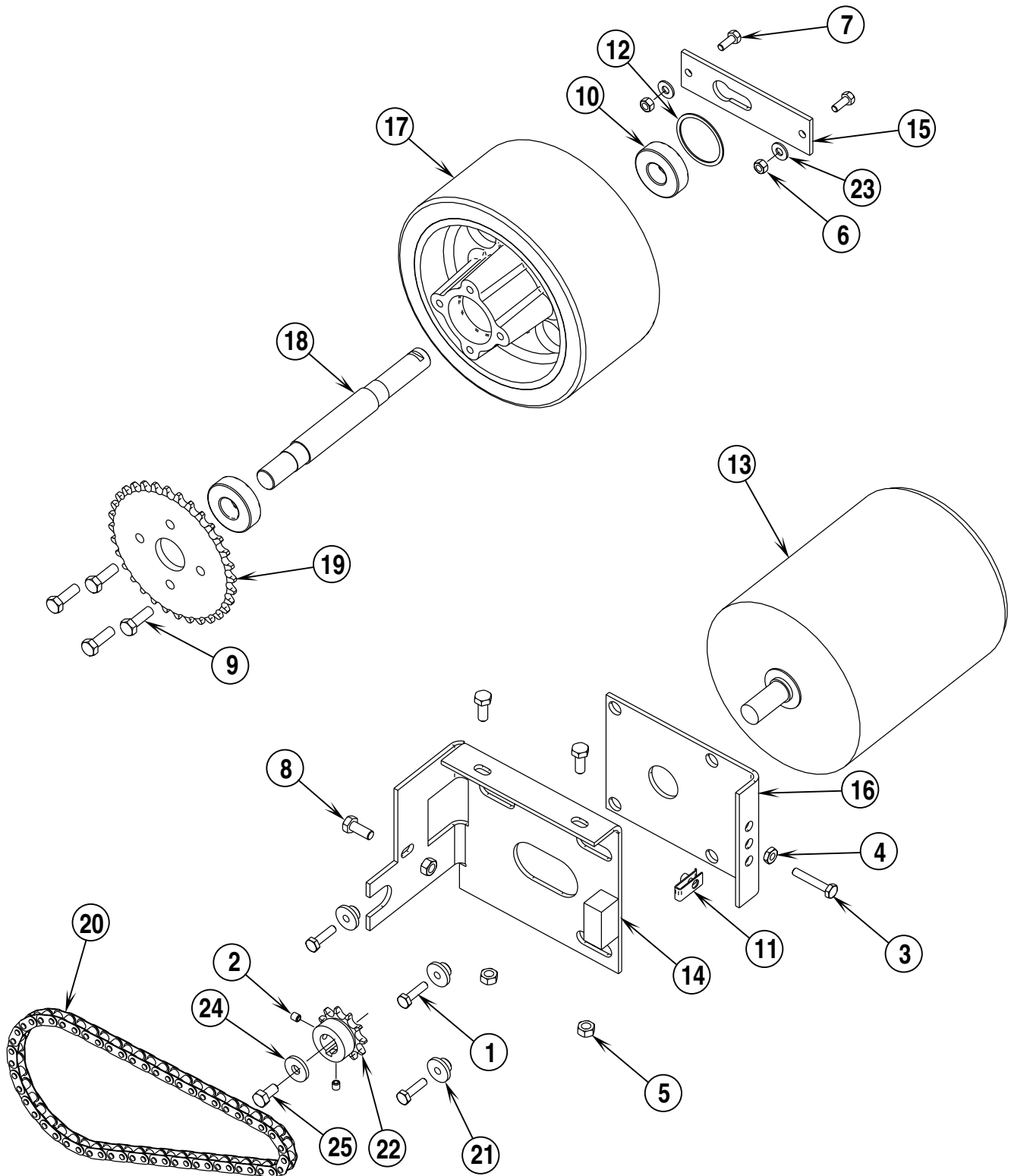

99-8	DRIVE SYSTEM	BOOK E		
00-12	ConvertaMAX™ 20, 26 / BA 550, BA 650	E	4.3.1	9

Item	Ref. No.	Qty	Description
1	56002883	3	Scr, Hex Hd SS 1/4-20 x 1.00
2	56001841	2	Scr, Soc Set Loc 1/4-20 x .25
3	56003125	1	Scr, Hex Thd To Hd SS 1/4-20 x 1.50
4	56003145	1	Nut, Hex Jam 1/4-20
5	56003405	3	Nut, Hex Nyl Loc SS M8-1.25
6	56003426	2	Nut, Hex Nyl Loc SS M6-1.00
7	56003431	2	Scr, Hex Hd SS M6-1.00 x 16mm
8	56003435	3	Scr, Hex Hd SS M8-1.25 x 20mm
9	56003477	4	Scr, Hex Loc SS M8-1.00 x 25mm
10	56154091	2	Bearing, Ball
11	56009289	1	Nut, Retainer
12	56444731	1	Ring, Ret Int.
13	56026191	1	Motor, DC 1/2 HP
***	56397099	1	Bearing, B.E.
***	56397135	1	Bearing, F.E.
***	56397138	4	Brush Spring
***	56397139	4	Brush Assy
***	56397137	1	Brush Board Assy (Springs/Brushes)
14	56035602	1	Weldment, Bracket, Trac. Drive
15	56057763	1	Bar, Steel
16	56057833	1	Bracket, Tension-Traction Drive
17	56397001	1	Wheel
18	56397003	1	Axle
19	56397005	1	Sprocket
20	56397017	1	Chain, #40-32
21	56397085	3	Bushing
22	56741122	1	Sprocket
23	56002859	2	Wsh, Flt SAE SS 1/4
24	56009122	1	Wsh, Flt .34 x .93 x .12
25	56002929	1	Scr, Hex Hd Loc 5/16-18 x .62

*** = Replacement Parts for 56026191

99-8	20" SCRUB SYSTEM	BOOK E		
01-10	ConvertaMAX™ 20, 26 / BA 550, BA 650	E	4.3.1	11

Item	Ref. No.	Qty	Description
1	56001879	2	Wsh, Flt SAE 1/2
2	56002841	2	Nut, Hex Nyl Loc-Thin 3/8-16
3	56002918	2	Wsh, Flt SAE SS 1/2
4	56002959	2	Pin, Cotter Hair
5	56003335	1	Scr, Hex Loc SS 5/16-18 x .88
6	56003338	4	Scr, Hex Loc SS 3/8-16 x .75
7	56003405	6	Nut, Hex Nyl Loc SS M8-1.25
8	56003424	3	Scr, Socket Hd SS M6-1.00 x 20mm
9	56003426	10	Nut, Hex Nyl Loc SS M6-1.00
10	56003431	6	Scr, Hex Hd SS M6-1.00 x 16mm
11	56003435	6	Scr, Hex Hd SS M8-1.25 x 20mm
12	56003438	4	Nut, Hex Nyl Loc SS M10-1.50
13	56003450	2	Nut, Hex Nyl Loc SS M12-1.75
14	56003453	2	Scr, Hex Hd SS M12-1.75 x 35mm
15	56003454	4	Scr, Hex Thd To Hd SS M6-1.00 x 20MM
16	56003524	2	Scr, Flt Soc 3/8-16 x 2.00
17	56003533	4	Scr, Hex Hd SS M10-1.50 x 20mm
18	56009122	1	Washer
19	56172099	1	Hose, PVC Clear NOTE #1
	56459064	1	Hose, PVC Clear NOTE #2
20	56219932	2	Clamp, Hose SAE #6
21	56325611	1	Drive Lug, Polygon
22	56355488	1	Clamp, Hose SAE #96
23	56360627	2	Bushing
24	56478781	2	Bearing, Sleeve
25	56003523	2	Clevis Pin, .38 x 1.00
26	56003547	3	Wsh, Flt 6.4mm x 11mm x 1.6mm
27	56054018	2	Spacer, Steel
28	56057850	2	Plate, Steel
29	56057873	2	Plate, Steel
30	56111639	2	Wheel
31	56397037	1	Clutch Plate, Aluminum
32	56397070	1	Bracket, U-Brush Head
33	56397072	1	Bracket, Brush Head, Right
34	56397073	1	Bracket, Brush Head, Left
35	56397076	1	Weldment, Brush Head Cover
36	56397078	1	Weldment, Formed Tube
37	56397079	1	Motor
***	56397090	1	Bearing, B.E.
***	56397135	1	Bearing, F.E.
***	56397138	4	Brush Spring
***	56397139	4	Brush Assy
***	56397092	1	Brush Board Assy (Springs/Brushes)
38	56397111	1	Skirt, Bristle
39	56397112	1	Shroud, Motor
**	56325502	1	Pad Holder
**	56325504	1	Brush, Prolene Medium
**	56325505	1	Brush, ProLite Soft
**	56325506	1	Brush, MidLite 180 Grit
**	56325507	1	Brush, MidGrit Medium
**	56325508	1	Brush, Union Mix
**	56505201	1	Brush, MagnaGrit 46
**	56505203	1	Brush, DynaGrit 80
**	56505205	1	Brush, AgLite Grit 500

** = Not Included (optional)

*** = Replacement Parts for 56397079

NOTE #1:

ConvertaMAX™ 20 before SN1520384

BA 550 before SN1516364

NOTE #2:

ConvertaMAX™ 20 after SN1520383

BA 550 after SN1516363

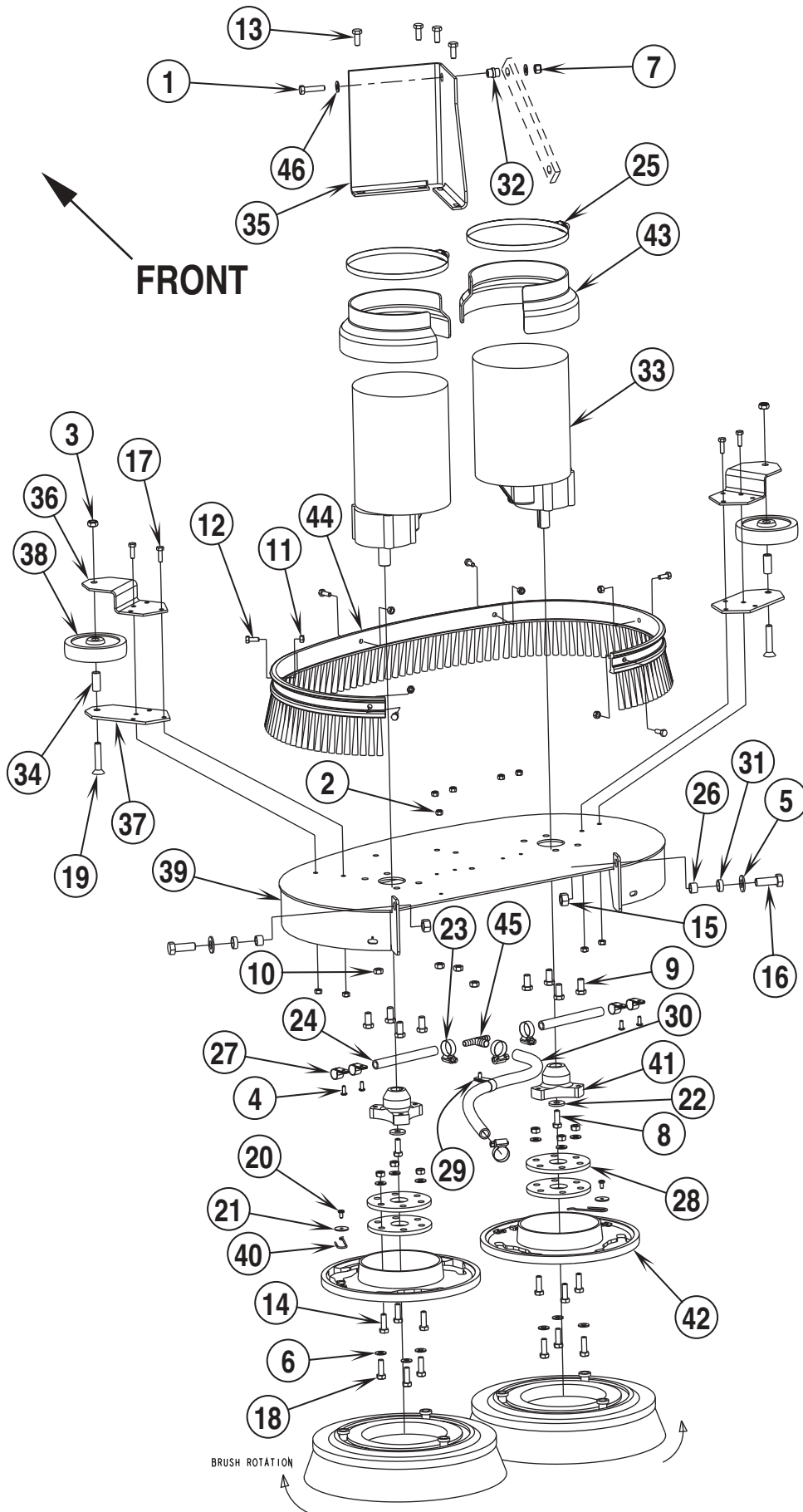

99-8	26" SCRUB SYSTEM (W/BOLT-ON SKIRT)	BOOK E		
01-5	ConvertaMAX™ 20, 26 / BA 550, BA 650	E	4.3.1	13

Item	Ref. No.	Qty	Description	Item	Ref. No.	Qty	Description
1	56009256	1	Scr, Hex Hd 5/16-18 x 1.38	34	56054018	2	Spacer, Steel
2	56002836	5	Nut, Hex Nyl Loc SS 10-24	35	56057845	1	Bracket, Scrub Head, Lift
3	56002841	2	Nut, Hex Nyl Loc-Thin 3/8-16	36	56057850	2	Plate, Steel
4	56002900	5	Scr, Pan Phil SS 10-24 x .50	37	56057873	2	Plate, Steel
5	56002918	2	Wsh, Flt SAE SS 1/2	38	56111639	2	Wheel
6	56002938	12	Wsh, Flt SAE SS 5/16	39	56397069	1	Weldment, Brush Head
7	56002701	1	Nut, Hex Nyl Loc 5/16-18	40	56397081	2	Spring Retainer
8	56003335	2	Scr, Hex Loc SS 5/16-18 x .88	41	56397082	2	Hub, Drive
9	56003338	8	Scr, Hex Loc SS 3/8-16 x .75	42	56397084	2	Brush Holder
10	56003405	10	Nut, Hex Nyl Loc SS M8-1.25	43	56397112	2	Shroud, Motor
11	56003426	10	Nut, Hex Nyl Loc SS M6-1.00	44	56397129	1	Skirt, Bristle
12	56003431	6	Scr, Hex Hd SS M6-1.00 x 16mm	**	56397066	1	Rubber Blade Kit
13	56003435	4	Scr, Hex Hd SS M8-1.25 x 20mm	45	56397300	1	Tee, Barb NOTE
14	56003436	6	Scr, Hex Hd SS M8-1.25 x 25mm	46	56001939	2	Wsh, Flt SAE 5/16
15	56003450	2	Nut, Hex Nyl Loc SS M12-1.75				
16	56003453	2	Scr, Hex Hd SS M12-1.75 x 35mm	**	56505760	2	Pad Holder
17	56003454	4	Scr, Hex Thd To Hd SS M6-1.00 x 20mm	**	56505761	2	Magna Grit 46 Brush
18	56003477	6	Scr, Hex Loc SS M8-1.00 x 25mm	**	56505762	2	Dyna Grit 80 Brush
19	56003524	2	Scr, Flt Soc 3/8-16 x 2.00	**	56505763	2	AgLite Grit 500 Brush
20	56009030	2	Scr, Pan Phil Thd Form 10-24 x .38	**	56505764	2	Prolene Brush
21	56009096	2	Wsh, Flt .193 x .875 x .060	**	56505765	2	Prolite Brush
22	56009107	2	Wsh, Flt SS .378 x 1.00 x .120	**	56505766	2	Union Mix Polish Brush
23	56219932	4	Clamp, Hose SAE #6	**	56505767	2	MidGrit 240 Brush
24	56257534	2	Hose, PVC NOTE	**	56505768	2	MidLite 180 Brush
25	56355488	2	Clamp, Hose SAE #96				
26	56360627	2	Bushing				
27	56385564	4	Clamp, P	* = Not Shown			
28	56407053	4	Thermoid Disk	** = Not Included (optional)			
29	56442003	1	Clamp, P	*** = Replacement Parts for 56027153			
30	56459064	1	Hose, PVC Clear				
31	56478781	2	Bearing, Sleeve				
32	56397024	1	Bushing				
33	56027153	2	Motor / Gear Unit				
***	56397090	1	Bearing, B.E.				
***	56397135	1	Bearing, F.E.				
***	56397138	4	Brush Spring				
***	56039276	4	Brush Assy				
***	56397048	1	Brush Board Assy (Springs/Brushes)				

NOTE: These items have changed part numbers. If you need to replace either of these items, you will need to order both Hoses (24) and Tee, Barb (45).

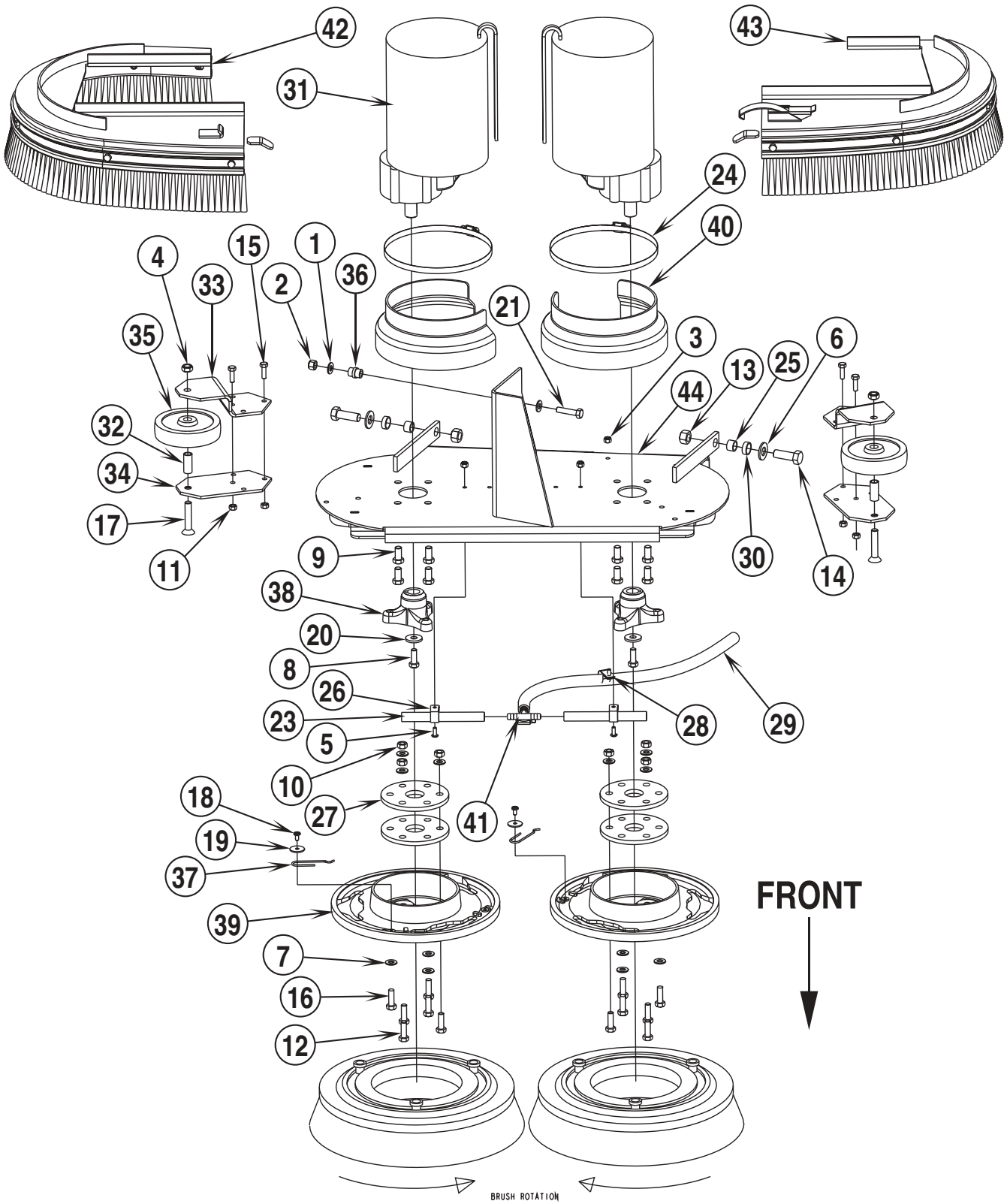

99-8	26" SCRUB SYSTEM (W/SLIDE-OFF SKIRTS)	BOOK E		
01-10	ConvertaMAX™ 20, 26 / BA 550, BA 650	E	4.3.1	15

Item	Ref. No.	Qty	Description	Item	Ref. No.	Qty	Description
1	56001939	2	Wsh, Flt SAE 5/16	36	56397024	1	Bushing
2	56002701	1	Nut, Hex Nyl Loc 5/16-18	37	56397081	2	Spring Retainer
3	56002808	3	Nut, Hex Nyl Loc SS 8-32	38	56397082	2	Casting, Hub
4	56002841	2	Nut, Hex Nyl Loc-Thin 3/8-16	39	56397084	2	Brush Holder
5	56003001	3	Scr, Pan Phil SS 8-32 x .62	40	56397112	2	Shroud, Motor
6	56002918	2	Wsh, Flt SAE SS1/2	41	56397300	1	Tee, Barb
7	56002938	12	Wsh, Flt SAE SS 5/16	42	56397341	1	Assy, Brush Cover, Right
8	56003335	2	Scr, Hex Loc SS 5/16-18 x .88	*	56397343	1	Brush Cover Weld't, Right
9	56003338	8	Scr, Hex Loc SS 3/8-16 x .75	*	56397346	1	Skirt, Bristle
10	56003405	6	Nut, Hex Nyl Loc SS M8-1.25	*	56003431	6	Scr, Hex Hd SS M6-1.00 x 16mm
11	56003426	4	Nut, Hex Nyl Loc SS M6-1.00	*	56003426	6	Nut, Hex Nyl Loc SS M6-1.00
12	56003436	6	Scr, Hex Hd SS M8-1.25 x 25mm	43	56397342	1	Assy, Brush Cover, Left
13	56003450	2	Nut, Hex Nyl Loc SS M12-1.75	*	56397344	1	Brush Cover Weld't, Left
14	56003453	2	Scr, Hex Hd SS M12-1.75 x 35mm	*	56397347	1	Skirt, Bristle
15	56003454	4	Scr, Hex Thd To Hd SS M6-1.00 x 20mm	*	56003431	6	Scr, Hex Hd SS M6-1.00 x 16mm
16	56003477	6	Scr, Hex Loc SS M8-1.00 x 25mm	*	56003426	6	Nut, Hex Nyl Loc SS M6-1.00
17	56003524	2	Scr, Flt Soc 3/8-16 x 2.00	*	56054306	1	Clamp, Toggle Latch
18	56009030	2	Scr, Pan Phil Thd Form 10-24 x .38	*	56002900	2	Scr, Pan Phil SS 10-24 x .50
19	56009096	2	Wsh, Flt .193 x .875 x .060	*	56002849	2	Nut, Hex Nyl Loc-Thin SS 10-24
20	56009107	2	Wsh, Flt SS .378 x 1.00 x .120	44	56397345	1	Scrub deck Weld't.
21	56009256	1	Scr, Hex Hd 5/16-18 x 1.38				
23	56257534	2	Hose, PVC	**	56505760	2	Pad Holder
24	56355488	2	Clamp, Hose SAE #96	**	56505761	2	Magna Grit 46 Brush
25	56360627	2	Bushing	**	56505762	2	Dyna Grit 80 Brush
26	56152617	2	Clamp, P	**	56505763	2	AgLite Grit 500 Brush
27	56407053	4	Thermoid Disk	**	56505764	2	Prolene Brush
28	56442003	1	Clamp, P	**	56505765	2	Prolite Brush
29	56459064	1	Hose, PVC Clear NOTE #1	**	56505766	2	Union Mix Polish Brush
	56397599	1	Hose, PVC Clear NOTE #2	**	56505767	2	MidGrit 240 Brush
30	56478781	2	Bearing, Sleeve	**	56505768	2	MidLite 180 Brush
31	56027153	2	Motor / Gear Unit				
***	56397090	1	Bearing, B.E.				
***	56397135	1	Bearing, F.E.				
***	56397138	4	Brush Spring				
***	56039276	4	Brush Assy				
***	56397048	1	Brush Board Assy (Springs/Brushes)				
32	56054018	2	Spacer, Steel				
33	56057850	2	Plate, Steel				
34	56057873	2	Plate, Steel				
35	56111639	2	Wheel				

* = Not Shown
** = Not Included (optional)
*** = Replacement Parts for 56027153

NOTE #1:

ConvertaMAX™ 26 before SN1517809
BA 650 before SN1516366

NOTE #2:

ConvertaMAX™ 26 after SN1517808
BA 650 after SN1516365

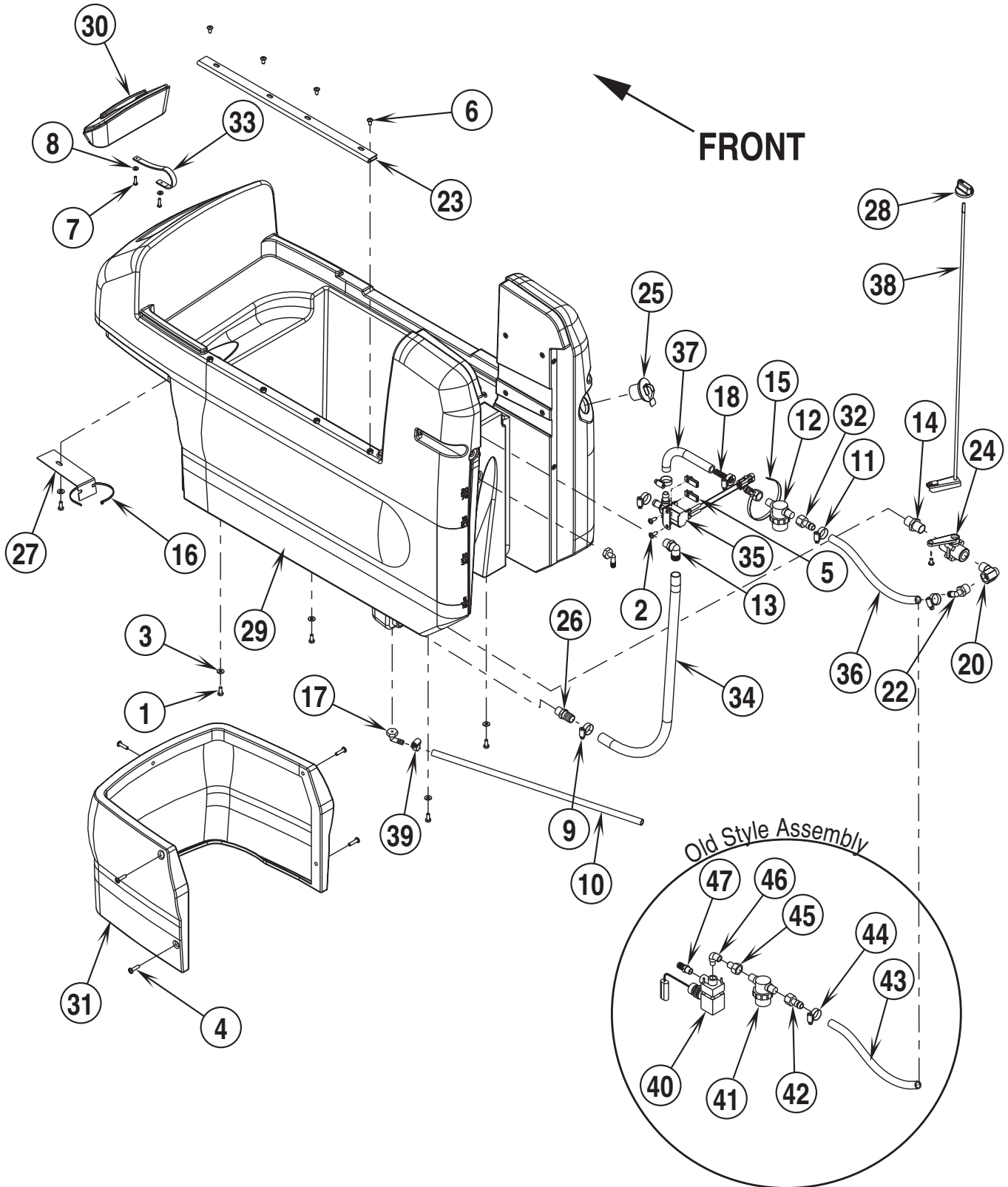

99-8	SOLUTION SYSTEM	BOOK E		
01-10	ConvertaMAX™ 20, 26 / BA 550, BA 650	E	4.3.1	17

Item	Ref. No.	Qty	Description
1	56001836	5	Scr, Hex Hd 1/4-20 x .62
2	56002066	2	Scr, Pan Phil 1/4-20 x .62
3	56002098	5	Wsh, Flt SAE 1/4
4	56002292	5	Scr, Pan Phil 1/4-20 x 1.00
5	56009289	2	Nut, U multi-Thread 1/4-20
6	56003119	5	Scr, Pan Phil SS 1/4-20 x .50
7	56009005	2	Scr, Pan Phil SS Type B 10-16 x .75
8	56009205	2	Wsh, Flt SS #10
9	56112771	1	Clamp, Hose SAE #10
10	56201036	1	Hose, PVC
11	56219932	5	Clamp, Hose SAE #6
12	56260905	1	Strainer
13	56264442	1	Barb, 90 Elbow 3/4 x 3/8NPT
14	56412182	1	Nipple, Hex 3/4-14
15	56477613	1	Tie, Cable
16	56478523	1	Tie, Cable
17	56900033	2	Barb, 90 Elbow 3/8 x 1/2NPT
18	56048979	1	Compression Spring
19	56051836	1	Hook (Not Shown)
20	56055071	1	Street Elbow
21	56056190	1	Grommet
22	56056231	1	Elbow, Fitting
23	56056514	1	Hinge
24	56057830	1	Valve, Ball
25	56057852	1	Plug, Expansion
26	56057868	1	Fitting, Barb
27	56057904	1	Bracket, Exhaust Hose
28	56396201	1	Knob (after May 2000)
	56396145	1	Knob (before June 2000)
29	56397020	1	Tank, Solution
30	56397021	1	Lid, Solution
31	56397022	1	Cover, Front
32	56397145	2	Barb, Hose Female
33	56397167	1	Strap, Retaining
34	56397186	1	Tube, PVC .75
35	56397203	1	Solenoid Valve Assembly TSB 784
36	56397207	1	Hose, PVC
37	56397209	1	Hose, PVC
38	56397320	1	Flow Valve Weld't. (after May 2000)
	56397166	1	Flow Valve Weld't. (before June 2000)
39	56756364	1	Clamp, Hose SAE #4

NOTE

40	56324247	1	Solenoid Valve Assembly TSB 784
*	56324506	1	Viton Seal Kit
*	56324507	1	EPDM Seal Kit
41	56260905	1	Strainer
42	56397145	1	Barb, Hose Female
43	56244986	1	Hose, PVC Clear
44	56219932	2	Clamp, Hose SAE #6
45	56759072	1	Adapter, Reducer Pipe Thread
46	56369632	1	Elbow, 90 Street
47	56373456	1	Barb, Adapter 1/2 x 1/4NPT

NOTE:

ConvertaMAX™ 20 before SN1520384 / ConvertaMAX™ 26 before SN1517809
BA 550 before SN1516364 / BA 650 before SN1516366

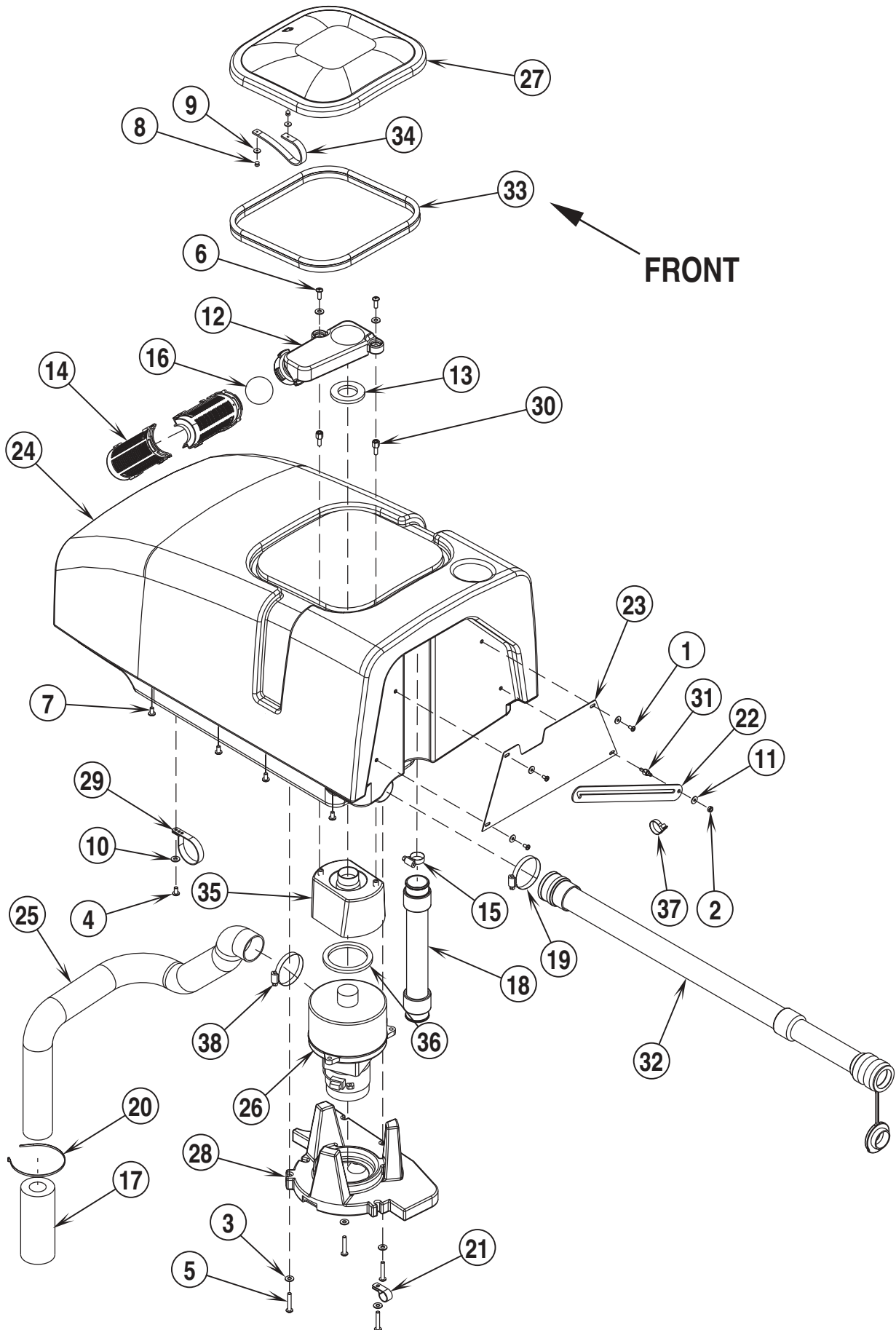

99-8	RECOVERY SYSTEM	BOOK E		
00-12	ConvertaMAX™ 20, 26 / BA 550, BA 650	E	4.3.1	19

Item	Ref. No.	Qty	Description
1	56002043	3	Scr, Pan Phil 10-24 x .38
2	56002832	1	Nut, Hex Nyl Loc-Thin 10-24
3	56002859	6	Wsh, Flt SAE SS 1/4
4	56002900	1	Scr, Pan Phil SS 10-24 X .50
5	56002905	4	Scr, Pan Phil SS 1/4-20 x 1.50
6	56003067	2	Scr, Pan Phil SS 1/4-20 x 1.00
7	56003119	4	Scr, Pan Phil SS 1/4-20 x .50
8	56003293	2	Rivet, Pop A/S .125 x .38/.50
9	56009098	2	Wsh, Flt SS .125 x .500 x .036
10	56009205	1	Wsh, Flt SS #10
11	56009267	4	Wsh, Flt .202 x .562 x .040
12	56302142	1	Float Duct
13	56302165	1	Gasket
14	56324497	2	Cage, Float
15	56329145	1	Clamp, Hose SAE #24
16	56391690	1	Ball, Float
17	56391807	1	Foam, Acoustical
18	56392170	1	Hose Assembly
19	56440213	1	Clamp, Hose SAE #32
20	56478523	1	Tie, Cable
21	56486112	1	Clamp, P
22	56057508	1	Bar, Steel
23	56057860	1	Panel, Steel
24	56397023	1	Tank, Recovery (ConvertaMAX™ 20/26)
	56397150	1	Tank, Recovery (BA 550/650)
25	56397040	1	Hose, Vac Exhaust
26	56397041	1	Motor, Vac 24VDC
*	56397098	1	Carbon Brush Set
27	56397045	1	Lid
28	56397046	1	Vac Motor Duct
29	56397095	1	Clamp, Hose
30	56397096	2	Spacer Bolt
31	56397097	1	Stud, Hex
32	56397142	1	Drain Hose
33	56397151	1	Gasket
34	56397167	1	Strap, Retaining
35	56397303	1	Spacer, Vac Motor
36	56397307	1	Gasket, Vac
37	56477613	1	Tie, Cable
38	56049999	1	Clamp, Hose SAE #28

* = Not Shown

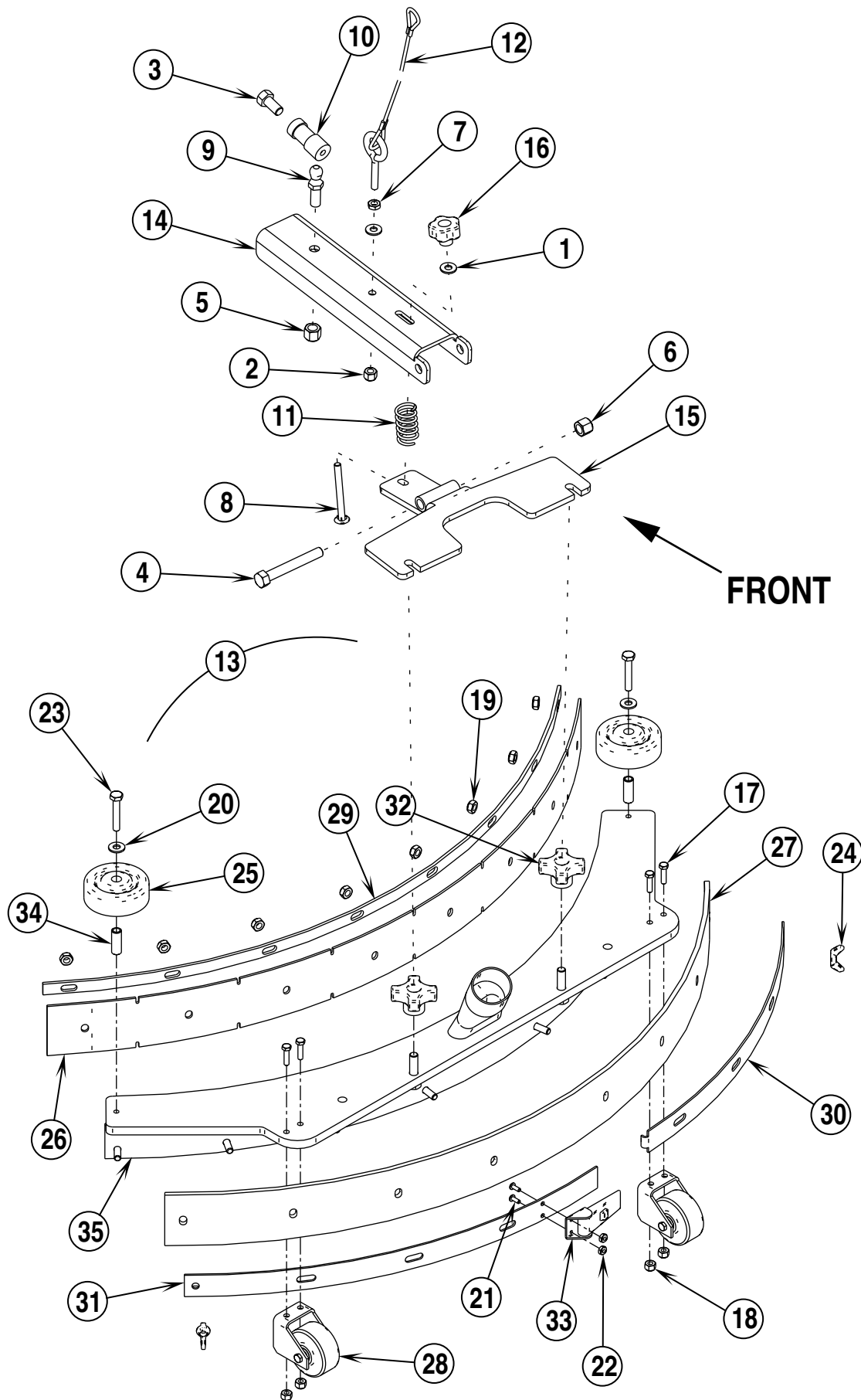

99-8	20" SQUEEGEE SYSTEM	BOOK E		
02-4	ConvertaMAX™ 20, 26 / BA 550, BA 650	E	4.3.1	21

Item	Ref. No.	Qty	Description
1	56002098	2	Wsh, Flt SAE 1/4
2	56002491	1	Nut, Hex Nyl Loc SS 1/4-20
3	56002597	1	Scr, Hex Hd 3/8-24 x .75
4	56002903	1	Scr, Hex Hd SS 3/8-16 x 2.75
5	56002951	1	Nut, Hex Nyl Loc 3/8-24
6	56003219	1	Nut, Hex Nyl Loc SS 3/8-16
7	56009087	1	Nut, Hex Jam 1/4-20
8	56009276	1	Scr, Carriage 1/4-20 x 2.50
9	56048953	1	Ball Joint, Stud
10	56049473	1	Ball Joint, Body
11	56056519	1	Compression Spring
12	56397009	1	Rope, Wire TSB 810
13	56397100	1	Squeegee Assembly (#17-35)
14	56397104	1	Bracket, Squeegee Mount
15	56397107	1	Weldment, Squeegee Bracket
16	56397108	1	Knob, Squeegee Mount
17	56002835	4	Scr, Hex Hd SS 10-24 x .75
18	56002836	4	Nut, Hex Nyl Loc SS 10-24
19	56002850	8	Nut, Hex Nyl Loc-Thin SS 1/4-20
20	56002859	2	Wsh, Flt SAE SS 1/4
21	56002909	2	Scr, Pan Phil SS 6-32 x .38
22	56002964	2	Nut, Hex Nyl Loc-Thin SS 6-32
23	56002993	2	Scr, Hex Loc SS 1/4-20 x 1.50
24	56009111	2	Nut, Wing SS 1/4-20
25	56363855	2	Wheel
26	56393285	1	Blade, Front (standard / oil resistant)
27	56393286	1	Blade, Rear (standard)
**	56393397	1	Blade, Rear (oil resistant)
28	56393755	2	Roller Assembly
29	56393761	1	Strap, Front
30	56393762	1	Strap, Rear Right
31	56393763	1	Strap, Rear Left
32	56396254	2	Knob
33	56471194	1	Latch Assembly
34	56471220	2	Bushing
35	56397102	1	Weldment, Squeegee Tool
**	56393395	1	Blade Kit, Standard
**	56393396	1	Blade Kit, Oil Resistant
**	56397329	1	Blade, Front-Tile Gum

** = Not Included (optional)

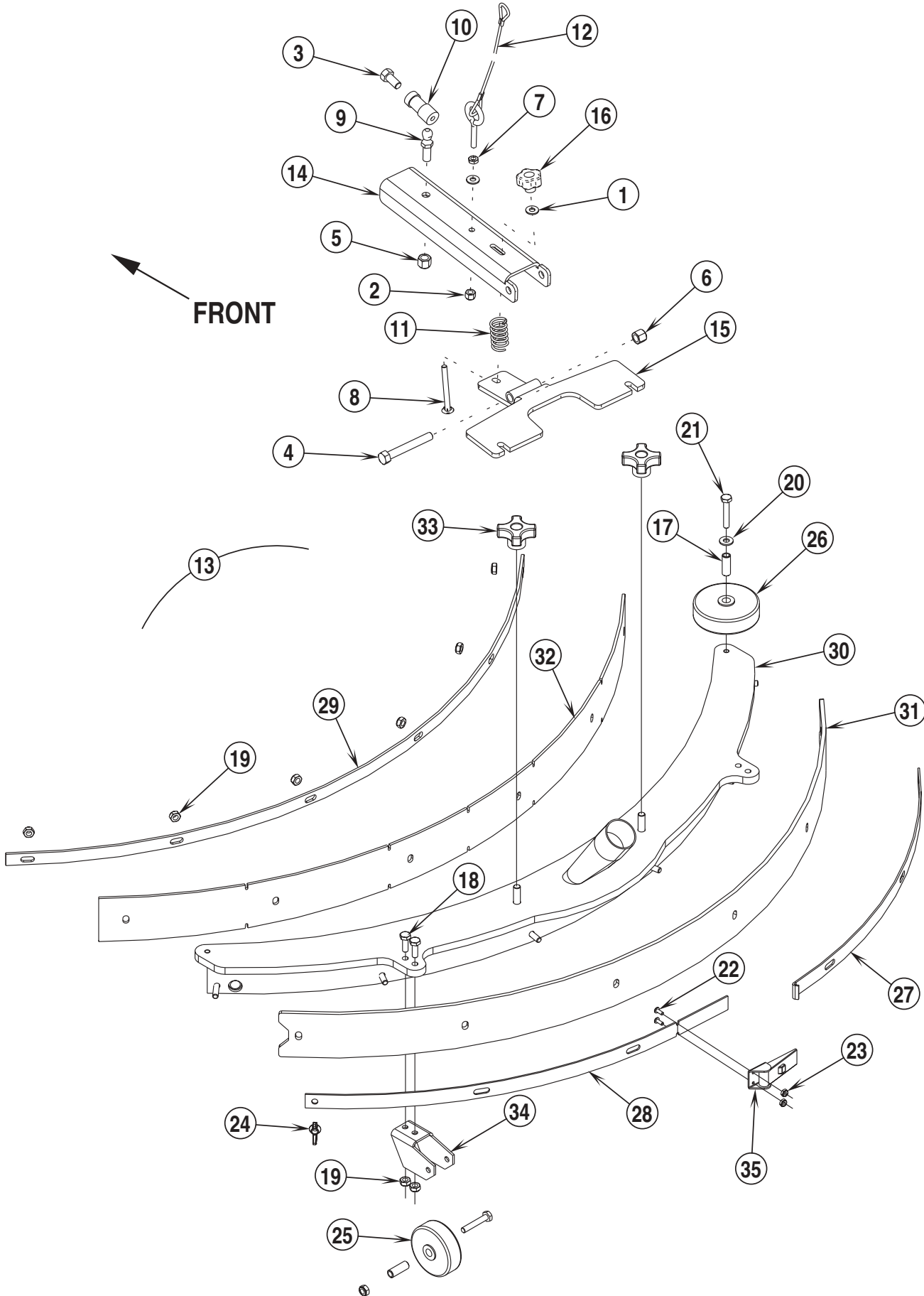

99-8	26" SQUEEGEE SYSTEM	BOOK E		
02-4	ConvertaMAX™ 20, 26 / BA 550, BA 650	E	4.3.1	23

Item	Ref. No.	Qty	Description
1	56002098	2	Wsh, Flt SAE 1/4
2	56002491	1	Nut, Hex Nyl Loc SS 1/4-20
3	56002597	1	Scr, Hex Hd 3/8-24 x .75
4	56002903	1	Scr, Hex Hd SS 3/8-16 x 2.75
5	56002951	1	Nut, Hex Nyl Loc 3/8-24
6	56003219	1	Nut, Hex Nyl Loc SS 3/8-16
7	56009087	1	Nut, Hex Jam 1/4-20
8	56009276	1	Scr, Carriage 1/4-20 x 2.50
9	56048953	1	Ball Joint, Stud
10	56049473	1	Ball Joint, Body
11	56056519	1	Compression Spring
12	56397009	1	Rope, Wire TSB 810
13	56397185	1	Squeegee Assembly (#17-35)
14	56397104	1	Bracket, Squeegee Mount
15	56397107	1	Weldment, Squeegee Bracket
16	56397108	1	Knob, Squeegee Mount
17	56471220	4	Bushing, .25 x .37 x 1.00
18	56002807	4	Scr, Hex Hd SS 1/4-20 x .75
19	56002850	12	Nut, Hex Nyl Loc-Thin SS 1/4-20
20	56002859	2	Wsh, Flt SAE SS 1/4
21	56002901	4	Scr, Hex Hd SS 1/4-20 x 1.50
22	56002909	2	Scr, Pan Phil SS 6-32 x .38
23	56002964	2	Nut, Hex Nyl Loc-Thin SS 6-32
24	56009048	2	Nut, Wing Loc 1/4-20
25	56324350	2	Wheel
26	56324499	2	Wheel, 3.00
27	56391286	1	Strap, Rear Right
28	56391288	1	Strap, Rear Left
29	56391290	1	Strap, Front
30	56396236	1	Tool Weldment
31	56391333	1	Blade, Rear (standard)
**	56391343	1	Blade, Rear (oil resistant)
32	56391334	1	Blade, Front (standard)
**	56391355	1	Blade, Front (oil resistant)
33	56396254	2	Knob
34	56409656	2	Bracket, Wheel
35	56471194	1	Latch Assembly
**	56391340	1	Blade Kit, Standard
**	56391342	1	Blade Kit, Oil Resistant
**	56397325	1	Blade, Front-Tile Gum
**	56397326	1	Blade, Front-Tile Linatex

** = Not Included (optional)

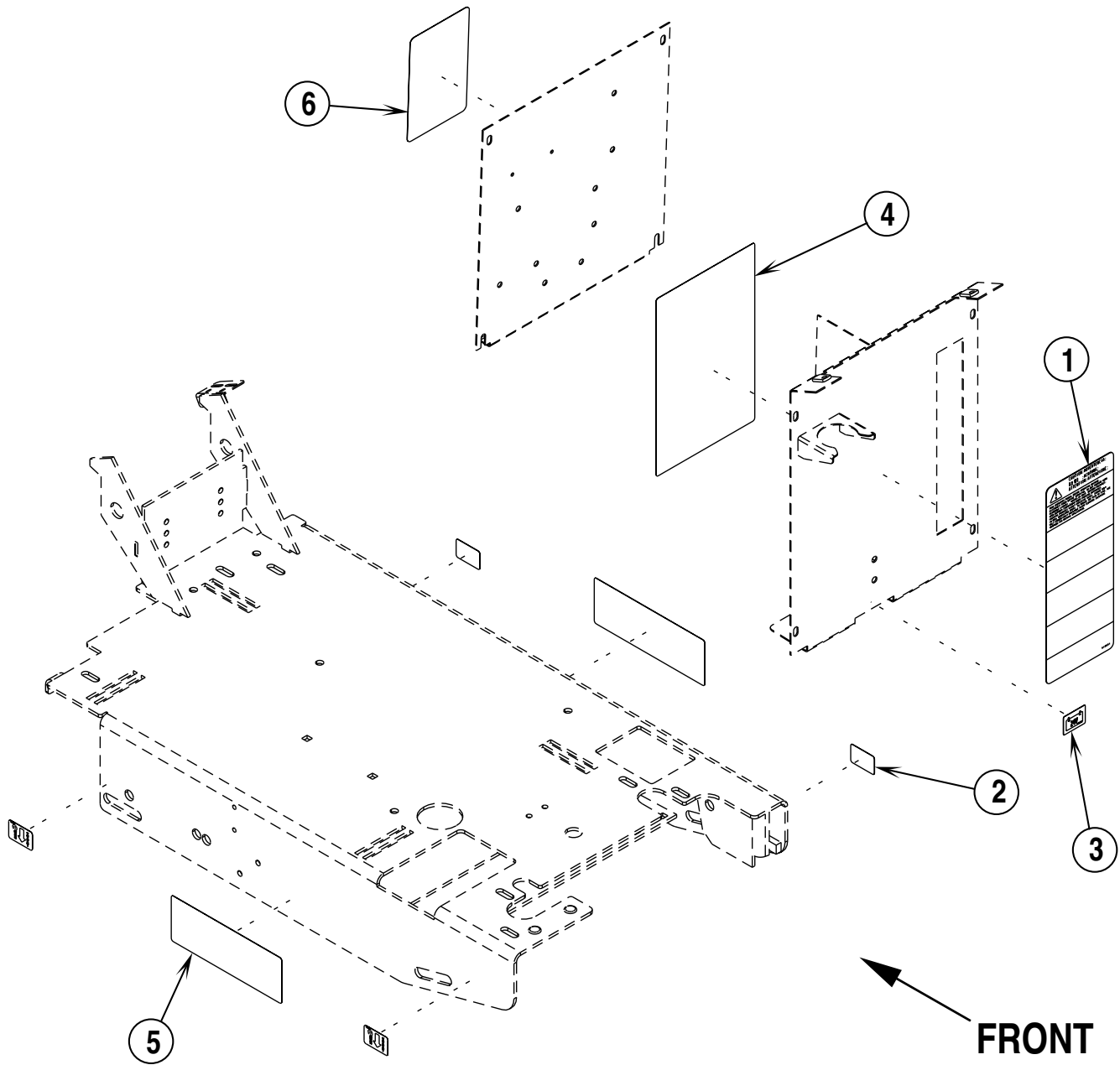

99-8	DECAL SYSTEM	BOOK E		
00-12	ConvertaMAX™ 20, 26 / BA 550, BA 650	E	4.3.1	25

Item	Ref. No.	Qty	Description
1	56014601	1	Decal, Caution
2	56015370	4	Decal, Tie Down
3	56054192	1	Decal, Charger
4	56016393	1	Decal, Electrical Schematic
5	56016648	2	Decal, ConvertaMAX™ 20
	56016649	2	Decal, ConvertaMAX™ 26
	56016650	2	Decal, BA550
	56016651	2	Decal, BA650
6	56016653	1	Decal, Battery Wiring

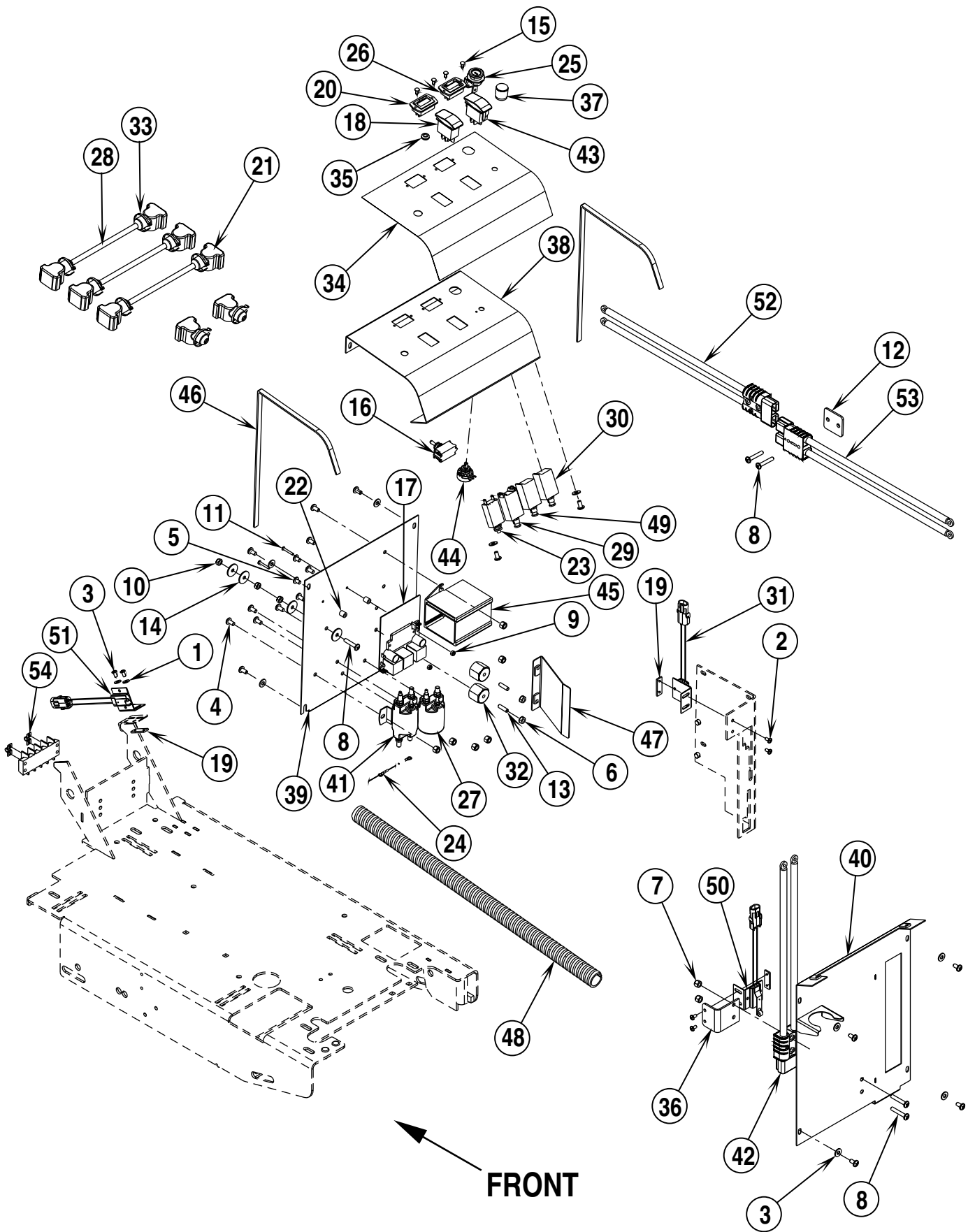

FRONT

99-8	ELECTRICAL SYSTEM	BOOK E		
01-10	ConvertaMAX™ 20, 26 / BA 550, BA 650	E	4.3.1	27

Item	Ref. No.	Qty	Description
1	56001954	2	Wsh, Flt SAE #10
2	56002043	6	Scr, Pan Phil 10-24 x .38
3	56002098	10	Wsh, Flt SAE 1/4
4	56002145	18	Scr, Pan Phil 1/4-20 x .50
5	56002462	2	Scr, Pan Phil 1/4-20 x .38
6	56002561	2	Nut, Hex W/SHPRF 1/4-20
7	56002708	8	Nut, Hex Nyl Loc 1/4-20
8	56002786	5	Scr, Pan Phil 1/4-20 x 1.50
9	56002830	2	Nut, Hex Nyl Loc 6-32
10	56002840	3	Nut, Hex Nyl Loc-Thin 1/4-20
11	56002858	2	Scr, Pan Phil 6-32 x 1.00
12	56397189	1	Spacer
13	56009203	2	Stud
14	56009060	4	Wsh, Flt SS .260 x 1.00 x .074
15	56009192	4	Rivet, Push Nylon Black
16	56301636	1	Switch, Toggle (Main Power)
17	56324023	1	Speed Control
18	56324272	1	Switch, Rocker (Solution)
19	56324310	3	Nut Plate
20	56372089	1	Fuel Gauge, Battery
21	56372673	8	Boot, Battery Post
22	56377721	2	Spacer
23	56387316	1	Circuit Breaker, 10 Amp (Auxiliary)
24	56389265	1	Rectifier
25	56393325	1	Bracket, Keylock
26	56393718	1	Hourmeter
27	56412179	1	Contactora, 24 VDC (Vacuum Motor)
28	56416445	3	Cable Assembly 4AWG
*	56398090	8	Terminal Clamp, Battery (BA 550 / BA 650)
29	56452193	1	Circuit Breaker, 40 Amp (20" model / Brush Motor)
	56263260	1	Circuit Breaker, 60 Amp (26" model / Brush Motor)
30	56454423	1	Circuit Breaker, 30 Amp (Vac Motor)
31	56462362	1	Switch, Vacuum
32	56469858	2	Standoff, Insulated
33	56478246	14	Tie, Cable
34	56016652	1	Decal, Instrument Panel (20" Model)
	56016663	1	Decal, Instrument Panel (26" Model)
35	56056190	1	Grommet
36	56393582	1	Bracket, Switch
37	56056596	1	Knob
38	56397025	1	Panel, Instrument
39	56397027	1	Panel, Front
40	56397038	1	Panel, Back, Weldment
41	56397088	1	Contactora, 24V SPDT (Brush Motor)
42	56397119	1	Charge Connector Assy
43	56397122	1	Switch, Rocker SPST (Brush Remove)
44	56397123	1	Potentiometer, 25K
45	56397124	1	Timer Module Assy
46	56397149	2	Gasket
47	56397164	1	Guard
48	56397190	1	Conduit
49	56454423	1	Circuit Breaker, 30 Amp (Wheel Drive Motor)
50	56462362	1	Switch, Interlock
51	56462362	1	Switch, Brush
52	56397187	1	Connector Assy
53	56397188	1	Connector Assy
54	56397184	2	Plates, Jumper (26" Model)
*	56397087	1	Harness, Wiring
*	56397208	1	Spacer, Battery (ConvertaMAX™ 20/26 only)

* = Not Shown

99-8	ELECTRICAL DIAGRAM	BOOK E		
01-10	ConvertaMAX™ 20, 26 / BA 550, BA 650	E	4.3.1	29

Item	Ref. No.	Qty	Description
A1	56324023	1	Speed Control
A2	56397124	1	Timer Module Assy
BT		N/A	Battery
D1		1	Diode
D2		1	Diode
F1	56387316	1	Circuit Breaker, 10 Amp (Auxiliary)
F2	56452193	1	Circuit Breaker, 40 Amp (20" model / Brush Motor)
	56263260	1	Circuit Breaker, 60 Amp (26" model / Brush Motor)
F3	56454423	1	Circuit Breaker, 30 Amp (Wheel Drive Motor)
F4	56454423	1	Circuit Breaker, 30 Amp (Vac Motor)
K1	56397088	1	Contactor, 24V SPDT (Brush Motor)
K2	56412179	1	Contactor, 24 VDC (Vacuum Motor)
L1	56324247	1	Solenoid Valve Assy NOTE #1
	56397203	1	Solenoid Valve Assy NOTE #2
M1	56397042	1	Vac Motor Assembly
M2	56026191	1	Wheel Drive Motor
M3	56397079	1	Motor, Brush Drive (20" model)
	56027153	1	Motor / Gear Unit, Brush Drive (26" model)
M4	56027153	1	Motor / Gear Unit, Brush Drive (26" model)
P1	56372089	1	Fuel Gauge, Battery
P2	56393718	1	Hourmeter
R1	56397123	1	Potentiometer, 25K
R2	56397029	1	Potentiometer, 5K
S1	56301636	1	Switch, Toggle (Main Power)
S2	56324272	1	Switch, Rocker (Solution)
S3	56397122	1	Switch, Rocker SPST (Brush Remove)
S4	56462362	1	Switch, Vacuum
S5	56462362	1	Switch, Interlock
S6	56462362	1	Switch, Brush
8	56397114	1	Cable Assy 6 AWG
10	56397118	1	Cable Assy 6 AWG
12	56397116	1	Cable Assy 6 AWG
14	56397117	1	Cable Assy 6 AWG
16	56397115	1	Cable Assy 6 AWG
*	56057920	1	Spacer, Angle, Batt Comp (For use with two 12V Batteries)

* = Not Shown

** = Not Included (optional)

NOTE #1:

ConvertaMAX™ 20 before SN1520384 / ConvertaMAX™ 26 before SN1517809

BA 550 before SN1516364 / BA 650 before SN1516366

NOTE #2:

ConvertaMAX™ 20 after SN1520383 / ConvertaMAX™ 26 after SN1517808

BA 550 after SN1516363 / BA 650 after SN1516365

We manufacture brushes and pad holders that will give you the best possible performance between machine and floor. Following are descriptions of the materials and their applications when used on the BA550 / BA650.

- Union Mix:** Medium grade natural fibers for polishing finished floors with standard-speed equipment. Recommended for use in place of white pads.
- ProLite:** Bristles are made from light-duty polypropylene for general scrubbing when you do not want to scratch or remove finish from the floor. Recommended for use in place of red pads.
- Prolene:** Polypropylene material for medium-duty scrubbing on concrete, terrazzo and vinyl floor tile. Recommended for use in place of green or blue pads.
- Magna Grit:** For extreme heavy-duty scrubbing or stripping of floors. This brush has extra large diameter silicon carbide grit impregnated synthetic bristles. Recommended for use in place of black pads.
- Dyna Grit:** For aggressive, heavy-duty scrubbing or stripping of floors. Recommended for use in place of brown pads.
- MidLite Grit:** For general purpose scrubbing of sealed or unsealed concrete, stone, terrazzo, quarry tile and other resilient hard floor surfaces. Recommended for use in place of green or blue pads.
- MidGrit:** For general purpose scrubbing when you need a lighter action for sealed or unsealed concrete, stone, terrazzo, quarry tile and other resilient hard floor surfaces. Recommended for use in place of green or blue pads.
- AgLite Grit:** For light scrubbing when used wet; buffing or polishing when used dry on urethane coated, sealed concrete or other resilient hard surface floors. Recommended for use in place of red or white pads.
- Short Trim Pad Holder:** Made with a structural foam block and center ring for correct pad centering. It has a "shower feed" design for getting solution to the floor.

- Ref. No.:** **BA550 BRUSHES**
 56325502 - Pad Holder
 56325504 - Prolene Medium
 56325505 - ProLite Soft
 56325506 - MidLite 180 Grit
 56325507 - MidGrit Medium
 56325508 - Union Mix
 56505201 - MagnaGrit 46
 56505203 - DynaGrit 80
 56505205 - AgLite Grit 500

- Ref. No.:** **BA650 BRUSHES**
 56505760 - Pad Holder
 56505761 - MagnaGrit 46
 56505762 - DynaGrit 80
 56505763 - AgLite Grit 500
 56505764 - Prolene
 56505765 - Prolite
 56505766 - Union Mix
 56505767 - MidGrit 240
 56505768 - MidLite 180 Grit

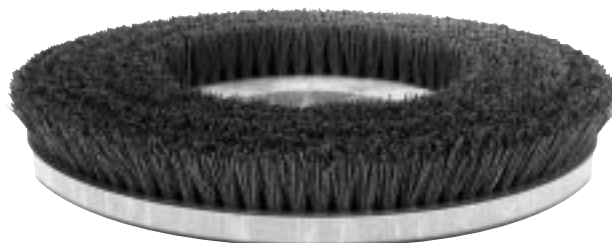

DANMARK

Nilfisk-Advance Nordic A/S
 Myntevej 3, 8900 Randers
 ☎ 86 42 84 33 – Fax 86 41 19 55

NORGE

Nilfisk-Advance AS
 Enebakkn, 119, 0680 Oslo, Postboks 196, Manglerud,
 0612 Oslo
 ☎ 22 08 63 50 – Fax 22 08 63 63
 Distriktsrepresentanter over hele landet

SVERIGE

Nilfisk-Advance AB
 Sjöbjörnsvägen 5, 117 67 Stockholm
 ☎ 085 55 944 00 – Fax 085 55 944 30

FINLAND/ SUOMI

BERNER Ltd. Facotek Department
 Etäleranta 4B, 00130 Helsinki
 ☎ +358 9 1345 1382

AUSTRALIA

Nilfisk-Advance Pty. Ltd.
 ACN 003 762 623
 Head office: 17 Leeds Street, Rhodes, N. S. W. 2138
 ☎ (02) 9736 1244 – Fax (02) 9736 3910
 Customer Responce Centre:
 ☎ 1 800 011 013

BELGIQUE / BELGIË/ LUXEMBOURG

Nilfisk-Advance s.a./n.v.
 Doornveld/ Sphere Business Park
 Industrie Asse 3, nr 11 – bus 41
 1731 Zellik-Asse
 ☎ (02) 467.60.50 Fax (02) 463.44.16

CANADA

Nilfisk-Advance Ltd.
 396 Watline Avenue
 Mississauga, Ontario L4Z 1X
 ☎ (905) 712-3260 – Fax (905) 712-3255

DEUTSCHLAND

Nilfisk-Advance AG
 Siemensstraße 25-27
 25462 Rellingen
 ☎ (041 01) 3990 – Fax (04101) 399191
 Zentraler Kundenservice
 ☎ für die Industrie: 0180 535 67 97
 ☎ Institutionen und Gebäudereiniger: 0180 500 11 70

FRANCE

Nilfisk-Advance S.A.
 BP 246
 91944 Courtaboeuf Cedex
 ☎ (01) 69.59.87.00 Télécopie (01) 69.59.87.01

HONG KONG

Nilfisk-Advance Ltd.
 2001, 20/F HK Worsted Mills
 Industrial Building
 31-39 Wo Tong Tsui Street
 Kwai Chung, N.T.
 ☎ 2427 59 51 – Fax 2487 5828

IRELAND

Nilfisk-Advance Ltd.
 28 Sandyford Office Park
 Dublin 18
 ☎ +353 1 2943838 – Fax +353 1 2943845

JAPAN

Nilfisk-Advance Inc.
 3-4-9 Chigasaki Minami
 Tsuzuki-Ku Yokohama 224
 ☎ 045-942-7741 – Fax 045-942-6545

MALAYSIA

Nilfisk-Advance Sdn Bhd
 Lot 2, 1st. Floor
 Lorong 19/1A
 46300 Petaling Jaya
 Selangor Darul Ehsan
 ☎ 03-7568188/03-7568189/03-7568388 – Fax 03-7566828

NEDERLAND

Nilfisk-Advance B.V.
 Flevolaan 7, Postbus 341
 1380 AH Weesp
 ☎ 0294-462121 – Fax 0294-430053

NEW ZEALAND

Nilfisk-Advance Limited
 477 Great South Road, Penrose
 Auckland
 ☎ (09) 525 0092 – Fax (09) 525 6440

SCHWEIZ / SUISSE

Nilfisk-Advance AG
 Ringstrasse 19, 9533 Kirchberg/Wil
 ☎ 719 23 52 83 – Fax 719 23 84 44

SINGAPORE

Nilisk-Advance Pte. Ltd.
 22, Woodlands Industrial Park E1
 Singapore 757740
 ☎ (65) 759 9100 – Fax (65) 759 9133

TAIWAN

Nilfisk-Advance Ltd.
 1 F, No.23, Lane 132, Sec. 2
 Ta An Road, Taipei
 ☎ 700 22 68 – Fax 784 08 43

UNITED KINGDOM

Nilfisk-Advance Limited
 Newmarket Road
 Bury St. Edmunds
 Suffolk IP 33 3SR
 ☎ (01284) 763163 – Fax (01284) 750562

USA

Nilfisk-Advance Inc.
 14600 21st Avenue North
 Plymouth, MN 55447-3408
 ☎ +1 800 989 2235 – Fax 1 800 989 6566

Nilfisk-Advance of America, Inc.
 300 Technology Drive
 Malvern, PA 19355
 ☎ (610) 647 647-6427

ÖSTERREICH

Nilfisk-Advance GmbH
 Vorarlberg Allee 46
 1230 Wien
 ☎ 1 616 58 30 – Fax 1 616 58 30 40

ESPAÑA

Nilfisk-Advance, S.A.
 Torre D'Ara
 Passeig del Rengle, 5 Pl.9-10
 E-08302 – Mataró (Barcelona)
 ☎ Tel. 93 741 24 00 – Fax: 93 757 80 20
 Central atención al cliente: 902 200 201
nilfisk@nilfisk-advance.es – www.nilfisk-advance.com
 Distribuidores y Servicio Técnico en toda España y Andorra

ITALIA

Nilfisk-Advance Italia Spa
 Località Novella Terza
 26862 Guardamiglio (LO)
 Italy
 ☎ +39 0377 414067-54 – Fax +39 0377 414097
www.nilfisk-advance.com

PORTUGAL

Nilfisk-Advance Lda.
 Rua Cândido de Figueiredo, 91-i, 1500-133 LISBOA
 ☎ 01/7784142 – Fax 01/7785613
 Porto 02/526766 – Fax 02/520739
 Açores 096/628092/3 – Fax 096/628129
 Madeira 091/228965 – Fax 091/228796

GREECE

Embiom S.A.
 Λεωφ. Βουλιαγμένης 60
 Αργυρούπολη
 164 52 Αθήνα
 ☎ 9950613 - Fax 9951680



Material composition of the Nilfisk BA550/650

